

DEC 23 1946

Copy 1
ARR NO. 3L03

NATIONAL ADVISORY COMMITTEE FOR AERONAUTICS

WARTIME REPORT

ORIGINALLY ISSUED

December 1943 as
Advance Restricted Report 3L03

CONSTRUCTION OF WIRE STRAIN GAGES FOR ENGINE APPLICATION

By J. Cary Nettles and Maurice Tucker

Aircraft Engine Research Laboratory
Cleveland, Ohio

NACA

WASHINGTON

NACA LIBRARY

LANGLEY MEMORIAL AERONAUTICS
LABORATORY

Langley Field, Va.

NACA WARTIME REPORTS are reprints of papers originally issued to provide rapid distribution of advance research results to an authorized group requiring them for the war effort. They were previously held under a security status but are now unclassified. Some of these reports were not technically edited. All have been reproduced without change in order to expedite general distribution.

NATIONAL ADVISORY COMMITTEE FOR AERONAUTICS

ADVANCE RESTRICTED REPORT

CONSTRUCTION OF WIRE STRAIN GAGES FOR ENGINE APPLICATION

By J. Cary Nettles and Maurice Tucker

SUMMARY

Detailed instructions are given for winding, baking, and mounting a phenolic resin-impregnated, bobbin-type wire strain gage that consists of Advance wire wound around a paper form. A brief description of some test equipment useful for establishing the merits of the techniques used in gage construction has been included.

Gages of the bobbin type were found suitable for applications on internal-combustion engines inasmuch as their performance was satisfactory over a temperature range considered ample for most engine tests, their characteristics were such that they were unaffected by hot engine oil, and their construction was relatively simple. The effect of gage length upon the strain-gage constant of the bobbin-type strain gage was found to be negligible for gage lengths greater than $3/8$ inch.

INTRODUCTION

Commercially available wire strain gages are satisfactory for use in most structural applications where high temperatures are not encountered and where space limitations are not critical. Strain gages intended for use on parts of internal-combustion engines in operation must obviously be able to withstand high temperatures as well as other adverse conditions.

The performance of a wire strain gage in operation at high temperatures is primarily determined by the adhesive used for bonding the wires in the gage and for attaching the completed gage to the test piece. Extensive research has been done on adhesives for strain-gage use at the Langley Memorial Aeronautical Laboratory. On the basis of the data obtained thus far, a thermosetting phenolic resin cement, manufactured by the Bakelite Corporation and designated BC-6035, was selected as being most suitable for strain gages in use at temperatures to 500° F.

This paper will describe the construction, application, and testing techniques for a phenolic resin-impregnated wire strain gage of the bobbin type. This type of strain gage was developed at Langley

Memorial Aeronautical Laboratory, Langley Field, Va., during the spring of 1942 for use in the determination of stresses in engine parts under operating conditions.

CLASSIFICATION OF GAGE TYPES

Wire strain gages may be classified, on the basis of the winding method used, as follows: spiral, grid, and bobbin types. Although the authors have not made use of the spiral-type gage, a brief discussion of this type will be included.

Spiral type. - The spiral-type gage is used only on cylindrical test pieces. The resistance wire is wound as a helix of small angle around the outside surface of the test piece after the test piece has been suitably insulated. In measurement of axial strain the spiral-type gage does not achieve the efficiency of the grid or bobbin types because only a component of the lateral strain, determined from Poisson's ratio, can act to vary the gage resistance; the component of the axial strain is considered negligible.

The spiral-type gage can be effectively used for measuring torsional strains in cylindrical parts and for measuring internal pressures in pipes.

Grid type. - The grid-type gage, originated by Mr. E. E. Simmons of the California Institute of Technology and Prof. A. C. Ruge of the Massachusetts Institute of Technology, requires the use of a pin jig for winding. Each of the NACA jigs, shown in figure 1, has two rows of pins with a space between rows equal to the desired gage length. Rice paper, folded under at each end so as to fit between the rows of pins, is used as a backing for the gage wires. The strain-gage wire is looped about each pin, alternating between the pins of each row. After the gage is cemented and baked, it is taken off the jig and the rice-paper folds are straightened so as to extend past the loops of the wire grid. The loops are cemented during the mounting of the strain gage on the test piece.

The grid-type gage, constructed as indicated, has proved unsatisfactory because of its relative difficulty of construction, because of frequent failures in service, and because of the required alteration of the pin jig when a change of gage length is needed.

Bobbin type. - The bobbin-type gage was developed by the NACA to avoid the objections mentioned for the grid-type gage. The bobbin-type gage is of rugged construction and can be wound either by hand or by machine. A strip of paper is cut to the desired dimensions and the gage wire wound about the paper. It has been found that a

gage 9/16 inch square, wound with sufficient turns to give a resistance of 500 ohms is of convenient size. The over-all thickness of the gage is approximately 0.010 inch. Changes in gage length are accomplished merely by varying the dimensions of the paper. Bobbin-type gages may be constructed for application either to plane surfaces or to cylindrical surfaces and will be treated in detail in the rest of this paper.

CONSTRUCTION OF BOBBIN-TYPE GAGES

Cement Baking Cycle

Bakelite cement BC-5035, when thinned with ethyl alcohol, is cured by the following baking cycle:

- A. 1 hour at 170° F
- B. 2 hours at 220° F
- C. $2\frac{1}{2}$ hours at 290° F

In step A the solvent is evaporated, in step B the cement is given a preliminary cure, and in step C the cement is given its final cure. Step B is used to allow the cement to cure without buckling of the gage form. After the cement is completely cured, the bond is strong, is resistant to creep, and cannot be dissolved. A strain gage mounted with Bakelite cement cannot be removed and used again.

Plane-Surface Gages

Kraft paper 0.003 inch thick is used as the gage form. The paper is given a thin coat of Bakelite cement and baked through steps A and B of the cycle. The consequent stiffening of the paper makes it possible to wind the wire, under tension, without buckling of the form. After the treated paper is cut to the desired dimensions and all rough edges are sanded and rounded, the form is ready to be wound.

A winding machine (fig. 1) has been developed by the NACA for simplification of the winding process. The machine essentially consists of two clamps geared to rotate together; the gage form is held between the clamps. A guide carried on a lead screw feeds the wire and provides the desired clearance between adjacent turns. Spacings of 45, 90, or 180 turns per inch can be obtained by selection of the proper lead screw.

After the wire has been wound on the gage form, the end turns of the winding are run diagonally from the body of the winding to the ends of the gage form and temporarily secured. The body of the winding is coated with cement, and thin rag paper is placed over the top and bottom surfaces of the winding as shown in figure 2(a). The gage assembly is clamped between two steel plates that are covered with wax paper on the clamping surfaces to prevent the gage from sticking to the plates. After the clamped assembly is subjected to steps A and C of the baking cycle, the steel plates are removed. Step B of the baking cycle is unnecessary because the clamping plates prevent buckling of the winding.

The tabs, which are made of 100-mesh brass screening, are tinned with lead solder before installation on the gage form. The excess turns extending past the uncemented portion of the winding are then looped around the tabs as shown in figure 2(b) and soldered to the tabs with lead, using Tin-Kwik flux. The soldered joints are carefully washed with water to remove any excess flux.

The tabs are then coated with Bakelite cement and baked. Steps A and C of the baking cycle are used. The cement penetrates the meshes of the brass screening, giving a strong mechanical bond between tab and gage form after baking. The portions of the end turns on the bottom surface of the gage are removed and the gage form is trimmed. The strain gage is then ready for attachment to a test piece.

Bobbin-type strain gages constructed as indicated, although primarily for use on plane surfaces, have been found usable on surfaces of relatively slight curvature.

Cylindrical-Surface Gages

Cylindrical-surface gages are wound in the same manner as plane-surface gages. Electrical insulating paper 0.005 inch in thickness is used for the gage form. The length of the form must be sufficient to cover the test section and to allow for clamping, as shown in figure 3. The excess gage wire is looped over the tabs and soldered to the tabs with lead. The form cannot be stiffened by application of Bakelite cement because the flexibility of the gage would be destroyed. In order to insure that the gage form does not buckle during the winding process, the gage wire is wound with less tension than that employed for winding plane-surface gages. The strain gage is not coated with Bakelite cement until just before assembly on the test piece.

Special Types

Several types of special gage construction have been developed for specific applications:

Torsion gages. - For measurement of torsional strains in shafting, the strain gage should be so located that the gage-element wires are at an angle of 45° to the shaft axis. Inasmuch as the strain gage is equally responsive to tensile or to compressive strains, it may be so mounted that the gage-element wires are parallel to either of the 45° directions. With this requisite in mind, a gage form is cut to the desired dimensions and the gage wire wound at an angle of 45° to the base line of the form. The strain gage is then completed in the same manner as described for gages on plane or cylindrical surfaces, depending upon the diameter of the shaft under consideration. A diagrammatic sketch of a torsion gage and its mounting position on a shaft are shown in figure 4.

Cross-wire gages. - The problem of temperature compensation is very important when steady strains are to be measured. The use of an unstrained or dummy gage in a Wheatstone bridge as a substitute for a standard resistor offers an effective solution to the problem; there are times, however, when this method cannot be used. Reference 1 suggests still another solution for the special case where unidirectional stress conditions exist - the self-compensating or cross-wire gage. The gage, in effect, consists of a standard wire strain gage with another gage wound on the same form at right angles to the first gage. Use of the gage as two arms of a Wheatstone bridge provides temperature compensation inasmuch as temperature changes affecting one winding must affect the other winding in a like manner.

The outstanding advantages of the cross-wire gage are that less space is needed than for the dummy gage and that its temperature compensation is usually the more effective of the two methods.

It was found necessary to subject the first winding to parts A and B of the basic baking cycle before starting the second winding. The defect listed for this type of gage in reference 1, that the gage cannot be effectively cemented in the lateral direction, can be remedied by use of the techniques previously described. A diagrammatic sketch of a cross-wire gage is shown in figure 5(a).

Strain rosettes. - A strain rosette is used for the determination of the magnitude and direction of the principal stresses in an engine part subjected to complex loading conditions. The transition from the cross-wire gage to the strain rosette is a logical one because the rosette requires only one additional winding. Enameled Advance wire is used for the gage-element wires. As in the case of the cross-wire

gage, each winding is put through parts A and B of the baking cycle before the next is added. Figure 5(b) shows a sketch of a 45° strain rosette.

INSTALLATION OF BOBBIN-TYPE GAGES

Bakelite cement BC-6035 is also used for attaching the strain gages to test pieces. This attachment necessitates the use of the baking cycle. An electric oven is used when gages are to be mounted on small engine parts; local heating is used when the engine part is too large for an oven. Electric-strip heaters attached to copper blocks that are fashioned to fit the specific test surface offer a simple yet effective method of local heating.

Installation on Plane Surfaces

The engine part is cleaned with carbon tetrachloride to remove any oil or grease. A thin coat of Bakelite cement is applied and the strain gage is placed in position. Layers of soft cardboard are built up over the gage as shown in figure 6 and a clamp is used to hold the assembly in place for baking. After steps A and C of the baking cycle are applied, the clamp and cardboard strips are removed. The strain gage is then ready for use.

Installation on Cylindrical Surfaces

The procedure for mounting cylindrical-surface strain gages is similar to that used for mounting plane-surface strain gages. The engine part is cleaned with carbon tetrachloride and coated with Bakelite cement. The strain gage is given its first coating of cement, on both top and bottom surfaces, and is placed between two strips of thin porous paper. This assembly is wrapped around the test part and the ends are inserted into a clamp, as in figure 3. The ends are pulled tightly to allow the strain gage to seat itself to the cylindrical surface.

The gage is then ready for the baking cycle in which steps A, B, and C are applied. After completion of the baking, the clamp is removed and the paper ends are cut off flush with the surface. After the soldered spots on each tab are scraped free of the outside layer of paper and the leads are soldered to the tabs, the gage is ready for use.

TESTING OF BOBBIN-TYPE GAGES

Gage Constants

The strain-gage constant is arbitrarily defined as the ratio of unit-resistance change to unit strain. The type of wire used for the gage will determine the maximum value of the constant obtained. Reference 2 discusses the various types of wire that are available for use in strain-gage construction. The authors of the present paper found that Advance wire, 0.001 and 0.0015 inch in diameter, gives very satisfactory results for engine applications.

For a given type of wire the gage length, measured along the gage-element wires, may have an appreciable effect upon the gage constant (fig. 7). These data were obtained from 30 gages mounted on steel beams of 1-inch square section that were loaded in bending as overhanging beams.

The portion of the winding taken up by the bends in the gage-element wires is practically unaffected by strain and tends to lower the gage constant. The percentage of the total length of the gage winding taken up by these bends will increase as the gage length is decreased.

Strain-Gage Test Equipment

Although the list of equipment necessary for effective strain-gage work is almost an endless one, certain basic apparatus can be used to perform most of the tests required. The equipment described will be limited to apparatus found essential for preliminary testing and for establishing the merits of the techniques used in gage construction.

NACA strain-gage bridge (fig. 8). - A standard Wheatstone bridge can be used to measure gage-resistance increments due to strain. It was found advisable, however, to make certain alterations that expedited strain-gage testing. A schematic wiring diagram of a bridge that was found very convenient is shown in figure 9. The bridge was designed to enable either a single-winding gage or a cross-wire gage to be tested. Single-winding gages are connected to terminals A and B; cross-wire gages are connected to terminals A, B, and D. The bridge gage R_2 , which is mounted on a cantilever bar inside the bridge box, is temperature-compensated by a dummy gage R_4 .

The resistance of R_2 may be smoothly varied by turning the strain-dial head on the micrometer screw that deflects the cantilever beam. The strain-dial head is calibrated in microinches per inch. With the

bridge in balance and the test gage R_1 unstrained, application of strain to the test gage will unbalance the bridge. The bridge can be rebalanced by varying the resistance of R_2 . The increment of strain, read on the strain-dial head, corresponds to the strain that changes the resistance of the test gage R_1 . This relation is true regardless of the initial resistance of the test gage R_1 inasmuch as a percentage change in the resistance of R_1 can always be balanced by an equal percentage change in the resistance of R_2 . A decade resistance unit R_5 is used either as the fourth arm of the bridge when single-winding gages are tested or as a balancing resistor when a cross-wire gage is tested.

Static-load beam. - The static-load beam (fig. 10) is used primarily for the application of known strains in the determination of strain-gage constants. The apparatus consists of an overhanging beam and a loading system. The bending moment along any section of the beam between supports is necessarily constant and thus facilitates the testing of several gages mounted on one test bar. An electric furnace may be used in conjunction with the static-load beam for temperature tests of strain gages under static load.

Dynamic calibrator. - The dynamic calibrator (fig. 11) was developed by the NACA for determination of strain-gage characteristics under dynamic loadings. The strain gage is mounted on a cantilever beam which, if desired, may be enclosed by an electric furnace. The amplitude of the cantilever-beam deflection can be varied by means of a double-eccentric cam. A choice of four deflection frequencies is provided by use of stepped pulleys.

Strain-Gage Temperature Tests

Bobbin-type strain gages constructed as described in this paper were tested for performance under dynamic-strain loadings over a temperature range considered ample for most engine applications. Figure 12 shows the percentage variation of the dynamic-signal voltage at various gage temperatures for an Advance-wire strain gage subjected to a dynamic strain of constant amplitude and frequency. The circuit used was a direct-current excitation system. The dynamic-signal voltage was found to have decreased less than 5 percent at a temperature of 500° F. Changes in elastic properties of the test bar due to test conditions (nonuniform heating of the test bar along its length) may have contributed to the decrease in gage-signal output at the higher temperatures. It should be noted that the lead used as solder was probably beginning to flow at the higher test temperatures.

Tests were also made to determine the effect of hot engine oil upon strain-gage performance. For these tests a wire strain-gage was tested on the static-load beam and then completely immersed in oil that was maintained at a temperature of 250° F. After immersion for 66 hours the strain gage was again tested on the static-load beam. Exposure to engine oil at this temperature was found to have no effect upon the characteristics of the strain gage.

CONCLUSIONS

The following conclusions apply to Bakelite-impregnated Advance-wire strain gages made and tested as described:

1. The gages were found to be relatively easy to construct.
2. The gages were not affected by hot engine oil.
3. The dynamic performance of the strain gages was only slightly affected by temperatures over a temperature range considered ample for most engine applications.
4. The effect of gage length upon the strain-gage constant was found to be negligible for gage lengths greater than 3/8 inch.

Aircraft Engine Research Laboratory,
National Advisory Committee for Aeronautics,
Cleveland, Ohio.

REFERENCES

1. de Forest, A. V., and Leaderman, H.: The Development of Electrical Strain Gages. NACA TN No. 744, 1940.
2. de Forest, A. V.: Characteristics and Aircraft Applications of Wire Resistance Strain Gages. Instr., vol. 15, no. 4, April 1942, pp. 112-114, 136, 137.

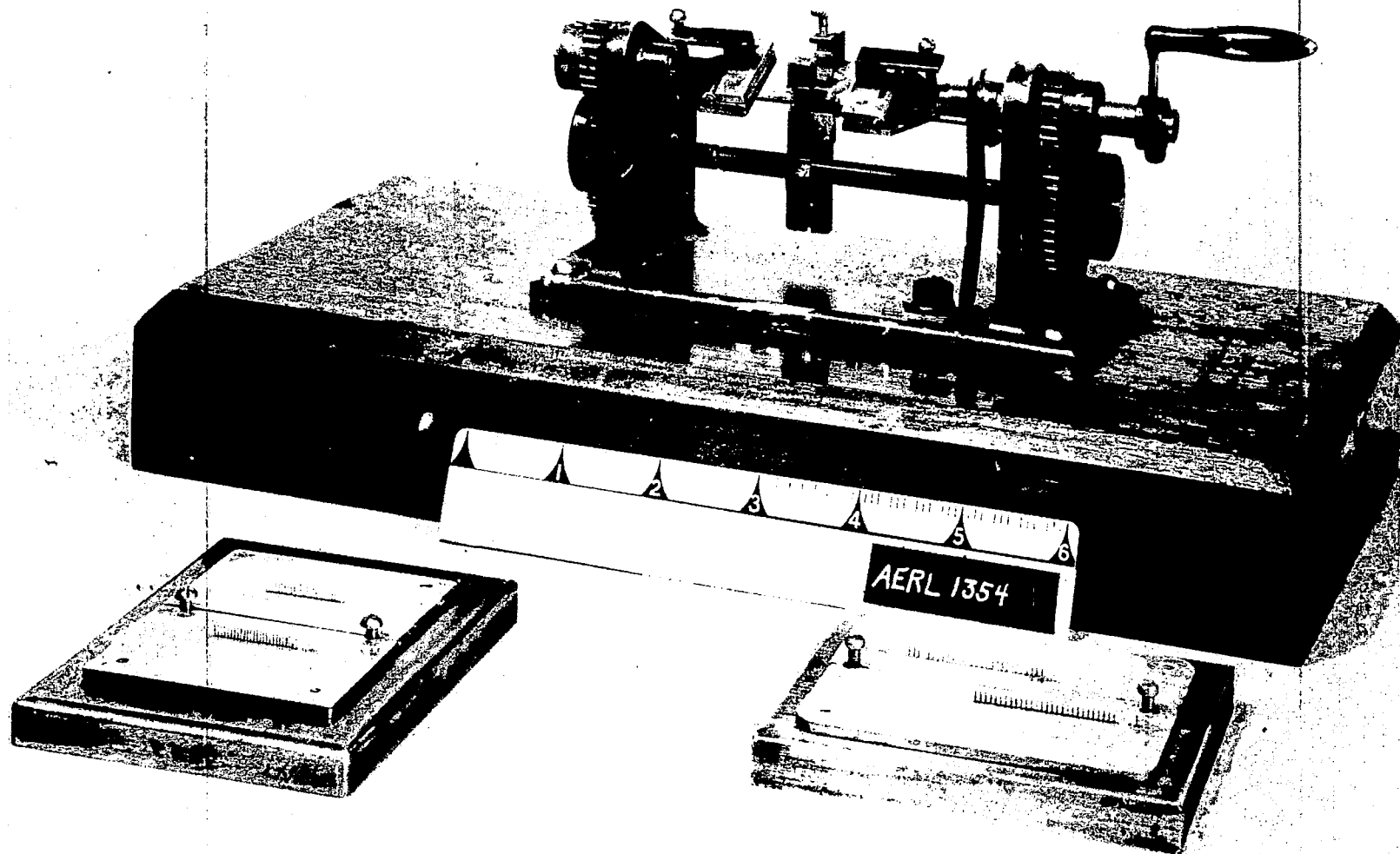
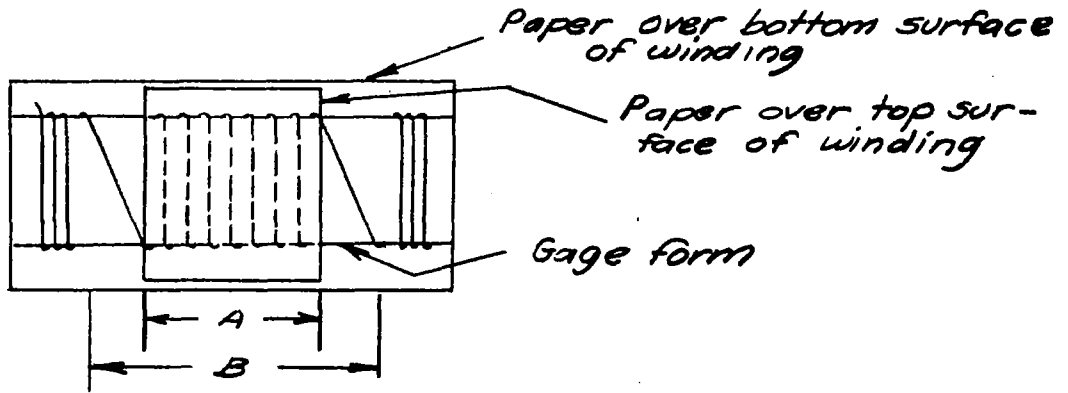

Figure 1.- Pin jigs and winding machine.

NACA

FIG. 1

Top surface of winding cemented over length A
 Bottom surface of winding cemented over length B



(a) Preparation of gage before mounting tabs.

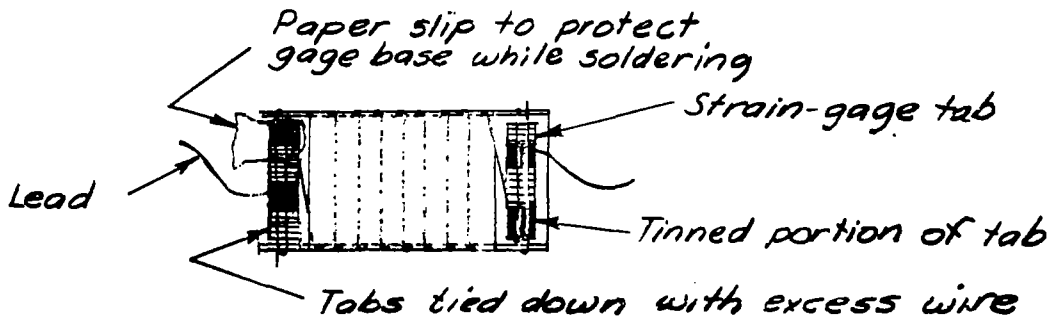

(b) Final assembly of gage.

Figure 2.- Construction details of a bobbin-type strain gage.

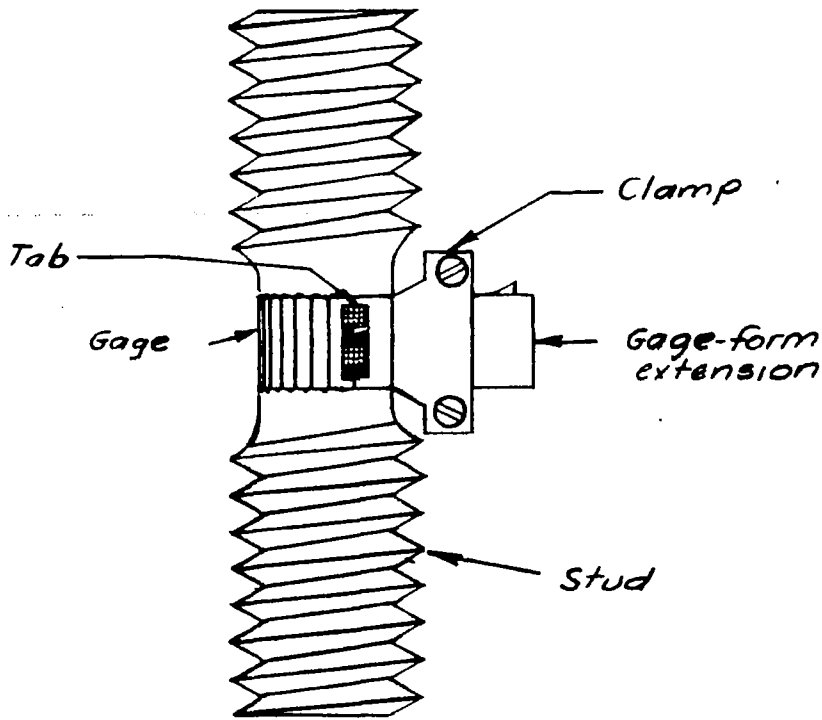

Figure 3.- Method of mounting a cylindrical gage prior to baking

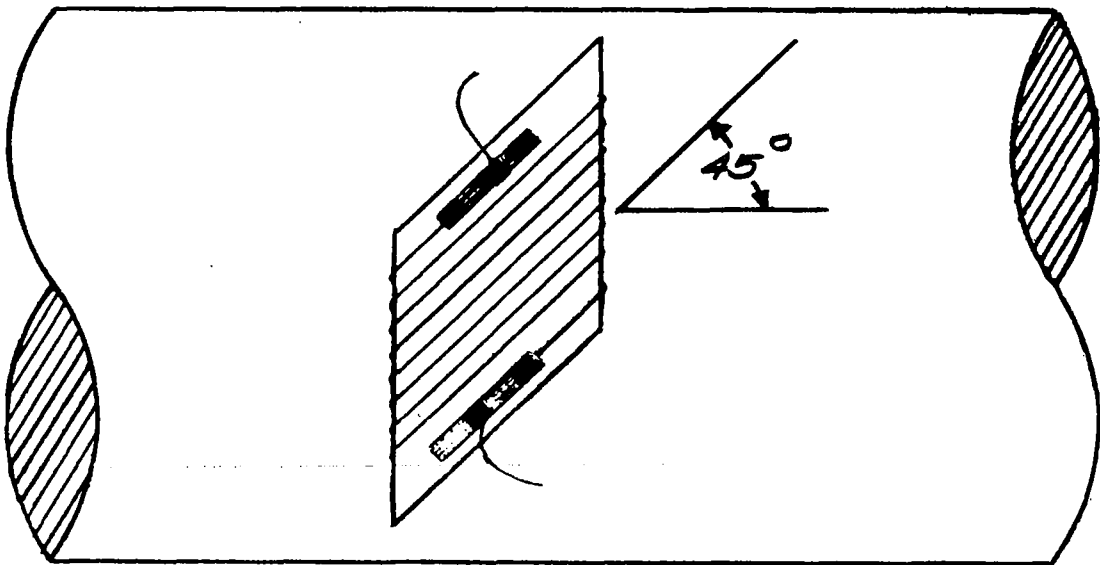

Figure 4.- Wire strain gage for measuring torsional strains in shafting

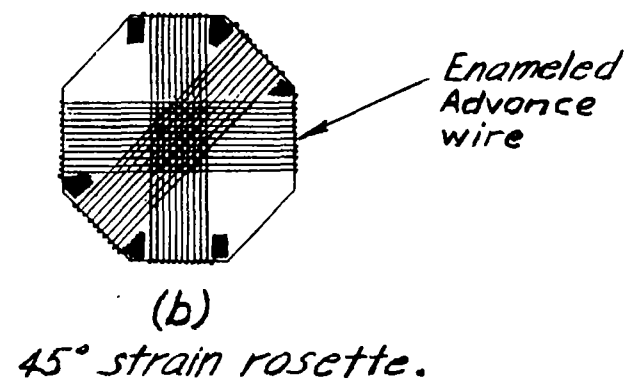
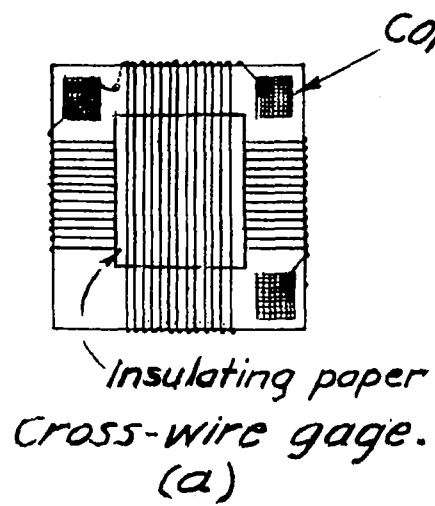

Figure 5.-
Construction details of a cross-wire
gage and strain rosette.

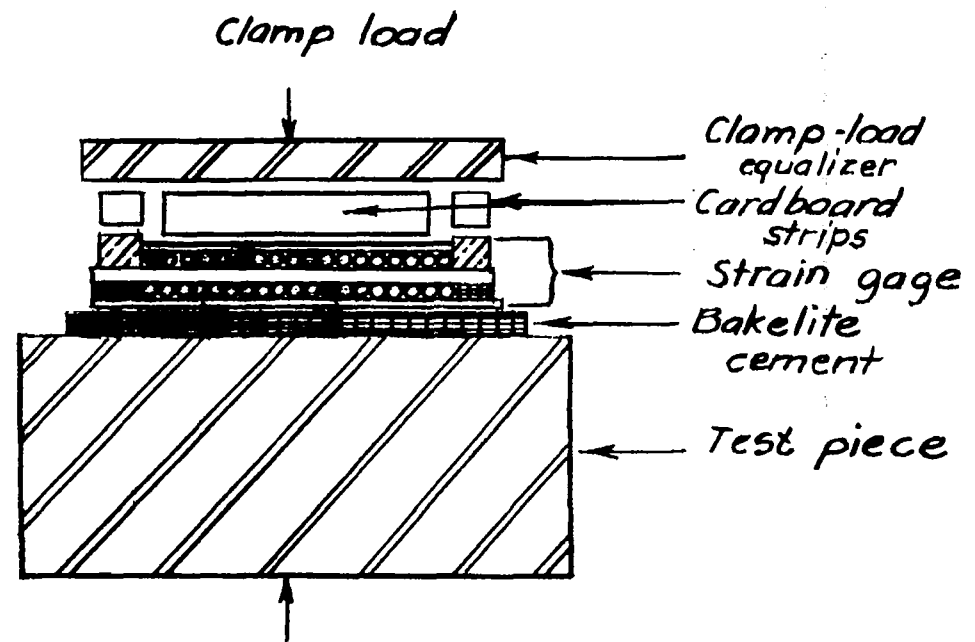

Figure 6.-
Cross section of a strain-gage
mounting assembly prior to baking.

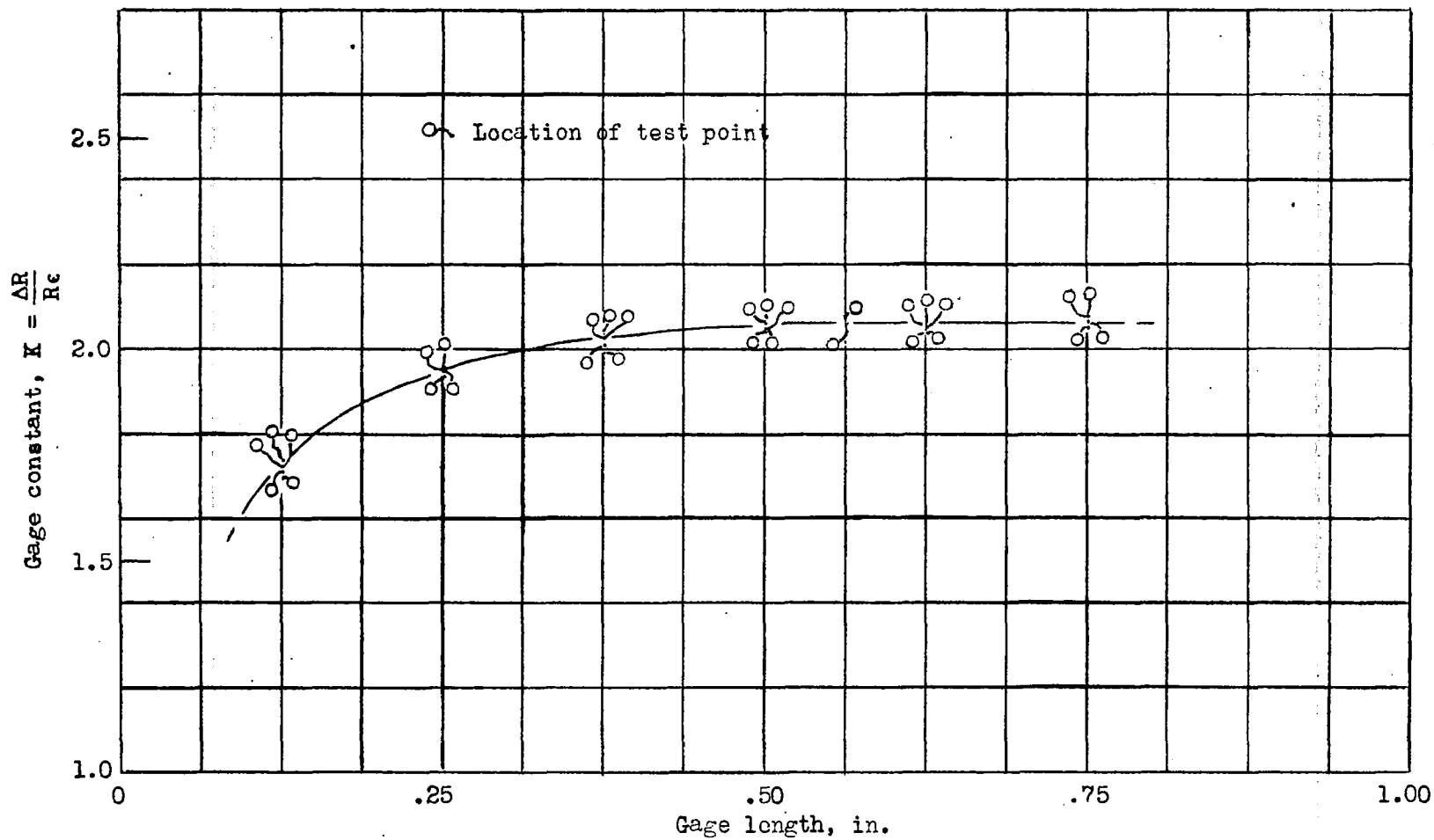
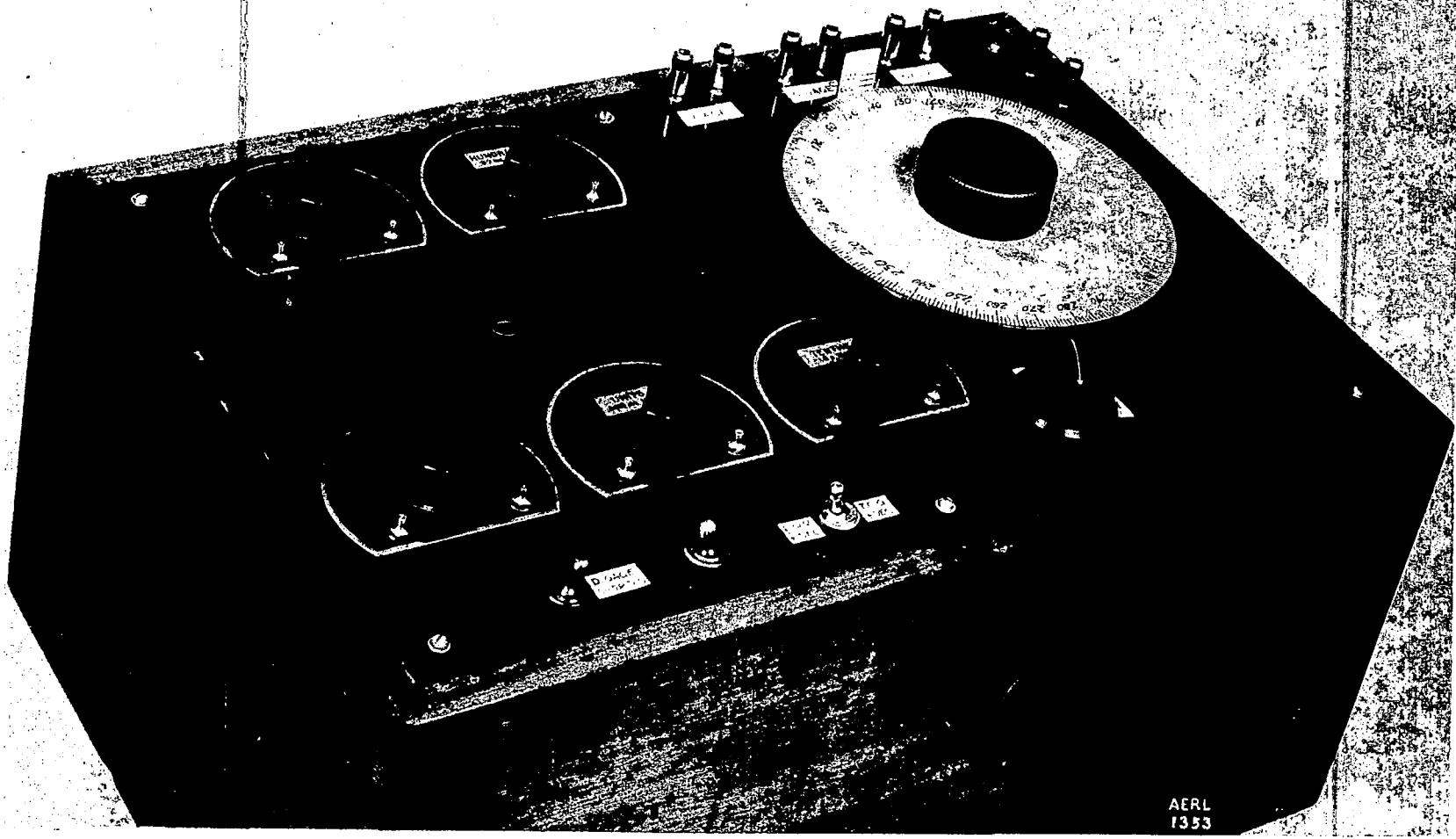
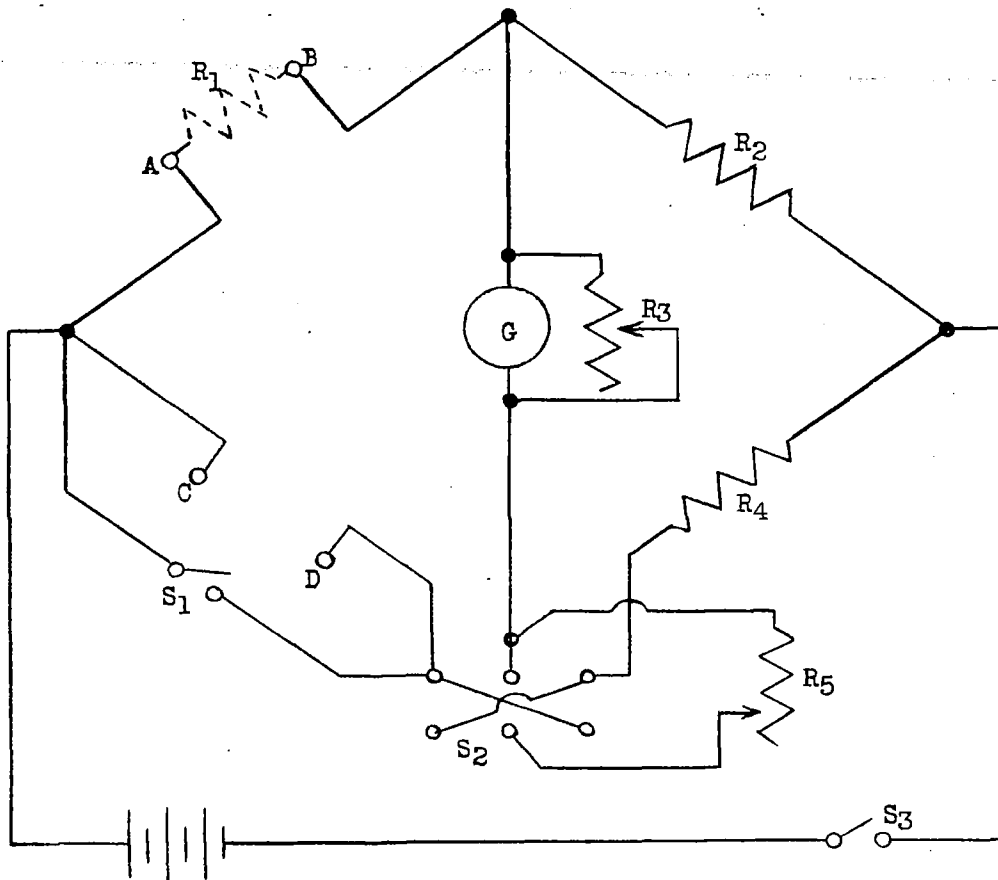

Figure 7. - $\Delta R/R =$ Unit resistance change effect of gage length on gage constant.
 $\epsilon =$ Unit strain



AERL
1353

Figure 8.- NACA strain-gage bridge.



- R₁ Test gage
- R₂ Bridge gage on cantilever
- R₃ Galvanometer resistor
- R₄ Bridge dummy gage
- R₅ Decade resistors
- S₁ Shorting switch, single pole single throw
- S₂ Selector switch, double pole double throw
- S₃ Power switch, single pole single throw
- G Galvanometer

Figure 9.- Schematic circuit diagram of the NACA strain-gage bridge.

NACA

Figs. 10, 11

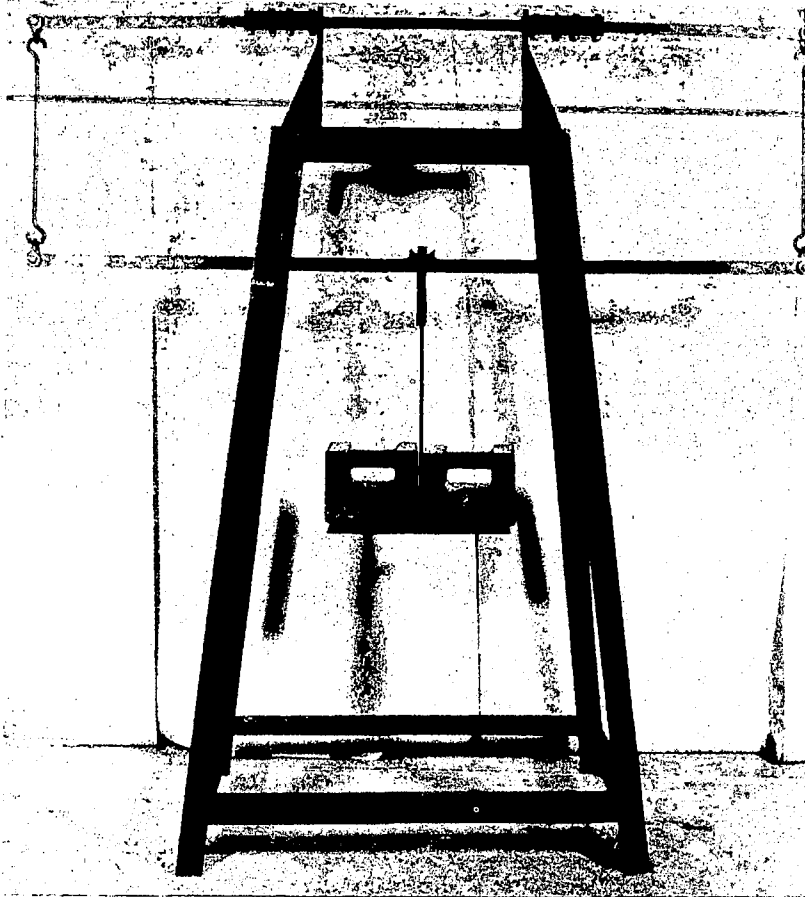
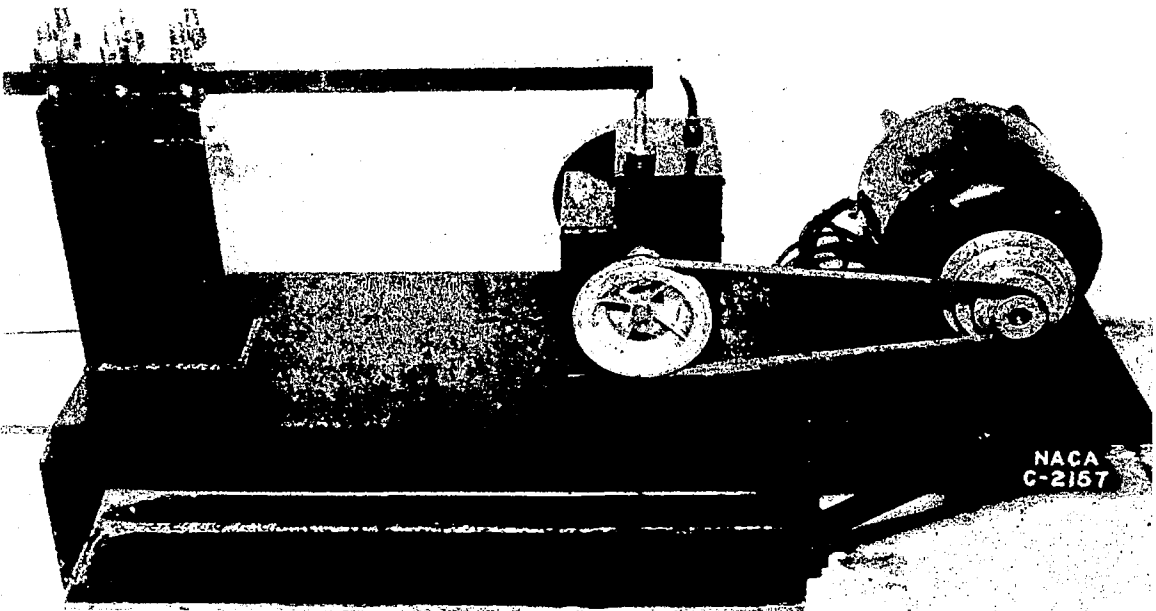

Figure 10.-
Static-
load
beam.

NACA
C-2156



NACA
C-2157

Figure 11.- Dynamic calibrator.

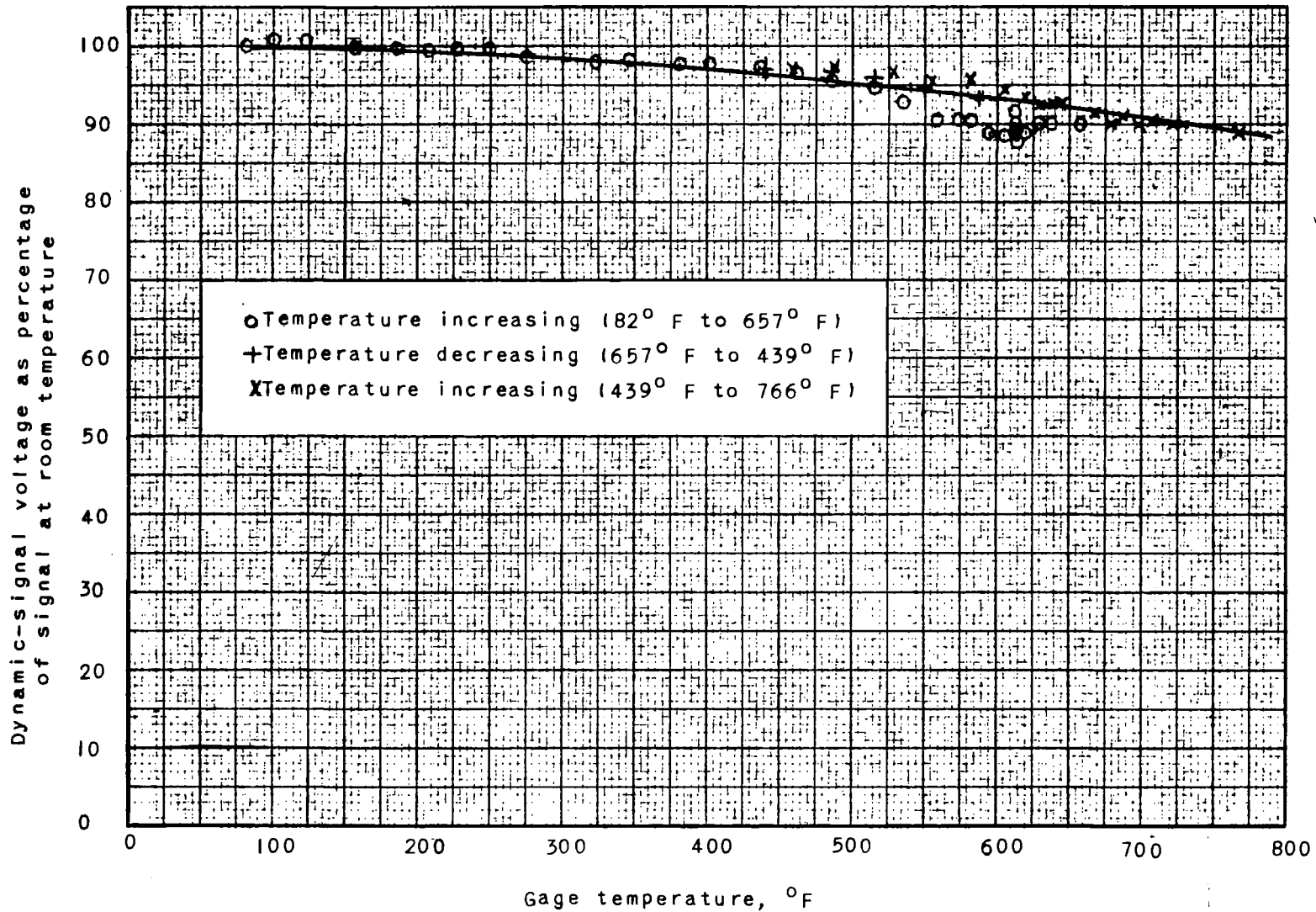

Figure 12. - Effect of temperature on the dynamic-signal output of a Bakelite-impregnated wire strain gage wound with 0.0015-inch-diameter Advance wire subjected to a vibratory strain of constant amplitude and frequency.

TDN FORM 89 (13 MAR 47)

Nettles, J. C.
Tucker, Maurice

DIVISION: Power Plants, Reciprocating (6)
SECTION: Testing (14)
CROSS REFERENCES: Engine components - Stress analysis
(32830.33); Strain gages (90700)

7-6-14-15

ATI- 8001

ORIG. AGENCY NUMBER

ARR-3103

REVISION

AUTHOR(S)

AMER. TITLE: Construction of wire strain gages for engine application

FORGN. TITLE:

ORIGINATING AGENCY: National Advisory Committee for Aeronautics, Washington, D. C.

TRANSLATION:

COUNTRY	LANGUAGE	FORGN. CLASS.	U. S. CLASS.	DATE	PAGES	ILLUS.	FEATURES
U.S.	Eng.		Unclass.	Dec '43	18	12	photos, diagrs, graphs, drwgs

ABSTRACT

Detailed instructions are given for winding, baking, and mounting phenolic, resin-impregnated, bobbin-type wire strain gage that consists of Advance wire wound around paper form. Bobbin-type gages of simple construction were found suitable for applications on internal-combustion engines, inasmuch as their performance was satisfactory over temperature range considered ample for most engine tests and their characteristics were such that they were unaffected by hot engine oil. Effect of gage length upon strain gage constant of bobbin-type strain gage was negligible for lengths greater than 3/8 in.

NOTE: Requests for copies of this report must be addressed to: N.A.C.A., Washington, D. C.