

Results of Fiber-Optic-Interferometer Density Measurements Performed in the Plasma-Opening-Switch Region of DM1*

Mike McFarland, Steve Gensler, Niansheng Qi and Mahadevan Krishnan
Alameda Applied Sciences Corp. 2235 Polvorosa Ave. San Leandro, CA 94577

Abstract

Fiber optic interferometer (FOI) measurements were performed in the plasma opening switch (POS) region of DM1. These are the first such measurements successfully accomplished on DM1 and constitute the first detailed look at the behavior of the plasma when driven by the DM1 current. It is found that when the cable guns are fired they produce a plasma, measured at $z \approx 2.8$ cm, $r \approx 8.0$ cm, of density $n \sim 1 \times 10^{15}$ cm⁻³ which falls off rapidly in z ($z = 0$ is taken to be the axis of the cable guns). The plasma has a transverse velocity of $v_z \sim 1$ cm/ μ s and is estimated to have a density at $z = 0$ cm of about $n \approx 5 \times 10^{15}$ cm⁻³. The shot to shot variation in the cable gun plasma is measured to be about $\Delta n/n \sim 10$ to 20%. When the Marx bank is fired, a burst of plasma is observed to travel axially toward the diode with velocity $v \approx 25$ cm/ μ s. The velocity of the burst increases with z , reaching $v \approx 42$ cm/ μ s by $z = 8.8$ cm. These velocities are close to the calculated Alfvén velocity, which is $v_A \approx 31$ cm/ μ s for DM1 parameters. The density of the burst is estimated to be about $n \sim 10^{16}$ cm⁻³ and appears to increase somewhat with z . The opening of the POS takes place when the leading edge of the burst is at about $z \approx 4.2$ cm. The burst of plasma is estimated to have a width of about $w \sim 3.8$ cm at $z = 2.8$ cm, prior to opening, and a width of $w \sim 10$ cm at $z = 8.8$ cm, after opening. Prior to opening, no plasma is observed downstream of the POS ($z = 8.8$ cm) greater than about $n_e \approx 1 \times 10^{13}$ cm⁻³. These results are significant not only because they allow preliminary comparison with theory, but also because they allow intelligent choices to be made concerning future measurements. A detailed understanding of the dynamics of the POS is crucial to improving the performance of DM1.

I. EXPERIMENTAL ARRANGEMENT

A schematic drawing of the FOI is shown in Fig. 1. The diode laser produces about $P \approx 25$ mW of power at $\lambda = 1550$ nm. The laser light is split, with roughly half the intensity passing through the measurement leg and half passing through the reference leg. An additional splitter is located in the measurement leg to determine the intensity of the beam after passing through the plasma. The measurement leg and reference leg signals are recombined in a variable coupler to produce the interference signal. The output of the variable coupler is fed to two high-

speed (~ 250 MHz) photo detectors (A and B). The photo detector for the intensity measurement (I) is identical to those used for the interferometer measurement. A piezo electric fiber stretcher is located in the reference leg and is used to maintain the output of the interferometer at the zero crossing point prior to a measurement and to calibrate the FOI (see below).

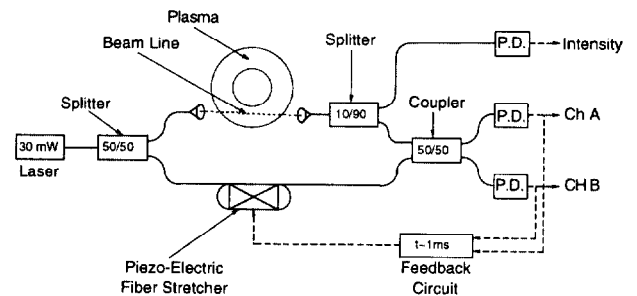

Figure 1. Schematic of FOI.

To eliminate noise the FOI and all of its associated electronics were housed in a -120 db screen-box located adjacent to the main data acquisition screen-room for DM1. The FOI electronics were triggered by a general TTL signal sent from the DM1 screen-room. In addition, to allow precise temporal alignment between the FOI and DM1 data, the Vac-Bdot-4 sensor on DM1 was recorded on the FOI oscilloscope to serve as a fiducial marker. The time delays of all the coaxial lines were accurately measured using a time-domain-reflectometer. The time delay of the optic cable was determined by precisely measuring its length and dividing by the published velocity of light in the fiber. The combined uncertainty in these measurements, and hence the uncertainty in the temporal alignment of the FOI and DM1 signals, is estimated to be about $\Delta t_{uncer} \approx 4$ ns.

The output of the FOI is given by $V_{sig} = V_{cal} \sin(\delta\phi)$ where V_{cal} is the calibration voltage and $\delta\phi$ is the phase shift between the reference-beam and the sample-beam, $\delta\phi = -r_e \lambda \int n_e dl = -r_e \lambda \langle n_e L \rangle$. Here r_e is the classical radius of the electron, λ is the wavelength of the laser light, n_e is the electron density, and L is the total sample path length. In practice the density is determined using $\langle n_e \rangle = -1/(r_e \lambda L) \sin^{-1}(V_{sig}/V_{cal})$, calculated on a computer, where L is the estimated path length of light through the plasma.

To establish V_{cal} a triangle-wave is fed to the fiber stretcher producing several full fringes. These fringes are recorded on the oscilloscope before each shot and

Report Documentation Page

Form Approved
OMB No. 0704-0188

Public reporting burden for the collection of information is estimated to average 1 hour per response, including the time for reviewing instructions, searching existing data sources, gathering and maintaining the data needed, and completing and reviewing the collection of information. Send comments regarding this burden estimate or any other aspect of this collection of information, including suggestions for reducing this burden, to Washington Headquarters Services, Directorate for Information Operations and Reports, 1215 Jefferson Davis Highway, Suite 1204, Arlington VA 22202-4302. Respondents should be aware that notwithstanding any other provision of law, no person shall be subject to a penalty for failing to comply with a collection of information if it does not display a currently valid OMB control number.

1. REPORT DATE

JUN 1999

2. REPORT TYPE

N/A

3. DATES COVERED

-

4. TITLE AND SUBTITLE

Results of Fiber-Optic-Interferometer Density Measurements Performed in the Plasma-Opening-Switch Region of DMI

5a. CONTRACT NUMBER

5b. GRANT NUMBER

5c. PROGRAM ELEMENT NUMBER

6. AUTHOR(S)

5d. PROJECT NUMBER

5e. TASK NUMBER

5f. WORK UNIT NUMBER

7. PERFORMING ORGANIZATION NAME(S) AND ADDRESS(ES)

Alameda Applied Sciences Corp. 2235 Polvorosa Ave. San Leandro, CA 94577

8. PERFORMING ORGANIZATION REPORT NUMBER

9. SPONSORING/MONITORING AGENCY NAME(S) AND ADDRESS(ES)

10. SPONSOR/MONITOR'S ACRONYM(S)

11. SPONSOR/MONITOR'S REPORT NUMBER(S)

12. DISTRIBUTION/AVAILABILITY STATEMENT

Approved for public release, distribution unlimited

13. SUPPLEMENTARY NOTES

See also ADM002371. 2013 IEEE Pulsed Power Conference, Digest of Technical Papers 1976-2013, and Abstracts of the 2013 IEEE International Conference on Plasma Science. Held in San Francisco, CA on 16-21 June 2013. U.S. Government or Federal Purpose Rights License.

14. ABSTRACT

Fiber optic interferometer (FOI) measurements were performed in the plasma opening switch (POS) region of DMI. These are the first such measurements successfully accomplished on DMI and constitute the first detailed look at the behavior of the plasma when driven by the DMI current. It is found that when the cable guns are fired they produce a plasma, measured at $z = 2.8$ cm, $r = 8.0$ cm, of density $n = 1 \times 10^{16}$ cm⁻³ which falls off rapidly in z ($z = 0$ is taken to be the axis of the cable guns). The plasma has a transverse velocity of $v_z = 1$ cm/ μ s and is estimated to have a density at $z = 0$ cm of about $n = 5 \times 10^{16}$ cm⁻³. The shot to shot variation in the cable gun plasma is measured to be about $\Delta n/n = 10$ to 20 %. When the Marx bank is fired, a burst of plasma is observed to travel axially toward the diode with velocity $v = 25$ cm/p. The velocity of the burst increases with z , reaching $v = 42$ cm / ps by $z = 8.8$ cm. These velocities are close to the calculated Alfvén velocity, which is $v_A = 31$ cm / μ s for DM 1 parameters. The density of the burst is estimated to be about $n = 10^{16}$ cm³ and appears to increase somewhat with z . The opening of the POS takes place when the leading edge of the burst is at about $z = 4.2$ cm. The burst of plasma is estimated to have a width of about $w = 3.8$ cm at $z = 2.8$ cm, prior to opening, and a width of $w = 10$ cm at $z = 8.8$ cm, after opening. Prior to opening, no plasma is observed downstream of the POS ($z = 8.8$ cm) greater than about $n = 1 \times 10^{16}$ cm⁻³. These results are significant not only because they allow preliminary comparison with theory, but also because they allow intelligent choices to be made concerning future measurements. A detailed understanding of the dynamics of the POS is crucial to improving the performance of DMI.

15. SUBJECT TERMS

16. SECURITY CLASSIFICATION OF:			17. LIMITATION OF ABSTRACT SAR	18. NUMBER OF PAGES 5	19a. NAME OF RESPONSIBLE PERSON
a. REPORT unclassified	b. ABSTRACT unclassified	c. THIS PAGE unclassified			

Standard Form 298 (Rev. 8-98)
Prescribed by ANSI Std Z39-18

$V_{cal} = V_{p-p} / 2$ where V_{p-p} is the peak-to-peak fringe voltage. The calibration signal is found to drift on a time scale on the order of minutes, which is about the time between trigger checks and the actual firing of a shot. To get an estimate of the magnitude of the drift in V_{cal} three calibrations were done before each shot and the results compared. It was found that V_{cal} drifts by about $\pm 10\%$ in 10 minutes.

Figure 2 shows a scaled drawing of the POS region of DM1 as it was configured during these measurements. The cable gun axis is taken to be $z = 0$. Two lines-of-sight were used during the measurements, one centered at $z = 2.8$ cm and the other at $z = 8.8$ cm. The ≈ 1 mm probe beam could be moved ± 4 mm about each of the z positions, at a fixed radius of $r = 8.0$ cm. The cord length from anode wall to anode wall at this r is $l = 20.0$ cm.

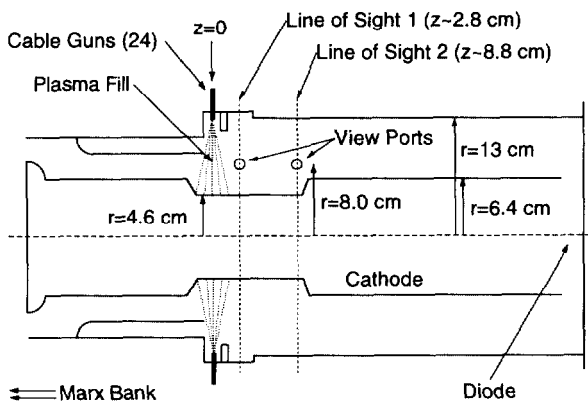

Figure 2. Schematic of POS region of DM1.

II. EXPERIMENTAL RESULTS – MEASUREMENTS PERFORMED ON THE CABLE GUN PLASMA

During trigger checks on DM1, the cable guns are fired and plasma is detected by the FOI at the $z \approx 2.8$ cm line-of-sight. The results of several measurements are shown in Fig. 3. The curves are plotted versus the time after the cable guns are fired, which is accurately determined using the Vac-Bdot-4 fiducial and the known delay time

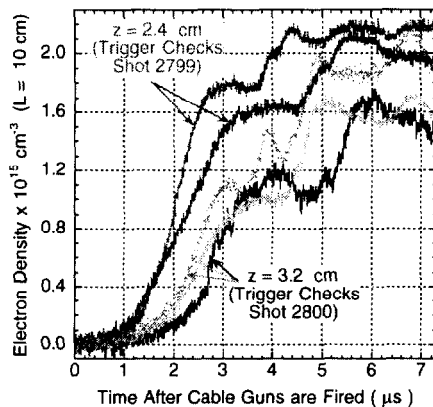

Figure 3. Cable gun plasma.

between the firing of the cable guns and the triggering of the Marx banks. Figure 3 shows two measurements made prior to shot 2799 at $z = 2.4$ cm and three measurements made prior to shot 2800 at $z = 3.2$ cm.

These measurements give some sense of the reproducibility of the cable gun fill. Taking the plasma density at $t = 3.0 \mu s$ (the approximate time of opening) gives $n = 1.62 \pm 0.15 \times 10^{15} \text{ cm}^{-3}$ for shot 2799 and $n = 0.89 \pm 0.18 \times 10^{15} \text{ cm}^{-3}$ for shot 2800, where the \pm variation is half the difference between the highest and lowest values for each shot. This represents a variation in the plasma fill of approximately 10% and 20% respectively for the two shots.

In addition to the variation in the plasma fill, Fig. 3 shows that the plasma density is lower at $z = 3.2$ cm than at $z = 2.4$ cm, and arrives later. The later arrival time indicates a propagation velocity for the cable gun plasma. The data from Fig. 3, along with additional plots taken at $z = 2.65$ cm (not shown in the figure) give an estimate of the velocity in the z direction of about $v_z \sim 1 \text{ cm}/\mu s$. The time delay between the traces is established by extrapolating the upward-going part of each curve back to the time axis. This velocity compares reasonably well with the measurements of other investigators who have found axial velocities of $v \approx 2$ to $3 \text{ cm}/\mu s$ for cable guns of this design and operating voltage[1]. A lower value is expected in our case since our measurements detect only the *transverse* component of the plasma velocity.

The decrease in plasma density with z is shown in Fig. 4, where the density at $t = 3.0 \mu s$ from Fig. 3 is plotted. The line is a least-squares-fit to the data, which extrapolates at $z = 0$ cm to $n \approx 5 \times 10^{15} \text{ cm}^{-3}$. Since the plot is semi-logarithmic, an exponential fall-off is suggested. The estimated density at $z = 0$ cm is consistent with other measurements that have shown $n \approx 5 \times 10^{15} \text{ cm}^{-3}$ on the axis of cable gun injected plasma[2].

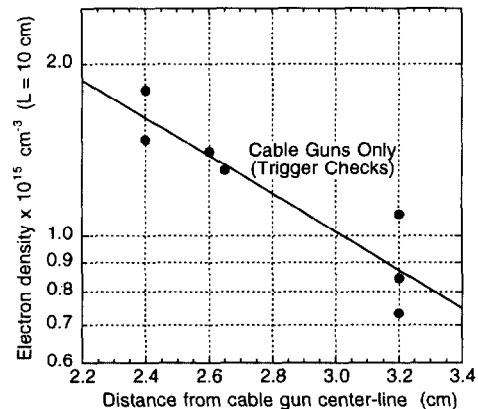

Figure 4. Cable gun density versus z .

Extrapolating Fig. 4 out to $z = 8.8$ cm gives a density of about $n \approx 1 \times 10^{13} \text{ cm}^{-3}$. It has been speculated that plasma of density $n_e \approx 1 \times 10^{14} \text{ cm}^{-3}$ might be present in DM1 downstream of the POS region prior to switch opening. A

High-gain FOI measurement taken at $z=8.8$ cm detected no plasma in this region prior to opening. The base sensitivity of the FOI stands at about $n_e \approx 1 \times 10^{13} \text{ cm}^{-3}$ taking $L = 20$ cm. If a pre-fill of plasma is present it must have a density less than about 10^{13} cm^{-3} . It is interesting to note that plasmas of density 10^{12} cm^{-3} have been measured in Hawk downstream of the POS prior to opening[1]. Such low densities are beyond the capability of the FOI.

III. EXPERIMENTAL RESULTS – MEASUREMENTS PERFORMED WHEN THE MARX BANK IS FIRED

Figure 5 shows a typical FOI measurement, taken at $z=2.4$ cm, when the Marx bank is fired (this will be referred to as ‘shot data’ in the remainder of the text). A cable-gun-only measurement, taken just prior to the shot, is also shown along with the Vac-Bdot-4 signal (note that the cable-gun-only measurement is displaced downward 0.2 for clarity). In comparing the cable-gun-only measurement to the shot data, it is interesting to note that the plasma density for the shot is not affected by the conduction current until *just prior* to opening. For the first $\Delta t \approx 200$ ns after the onset of conduction the shot data are nearly identical to the cable-gun-only data at this line-of-sight. Hence, even though the plasma fill has been conducting current for 200 ns, this current has had no effect on the plasma at this location ($z=2.4$ cm, $r=8.0$ cm). When the current does begin to affect the plasma, the onset is rapid and the result is significant. This is seen in Fig. 5 by the density jump towards the end of the conduction pulse and the subsequent rapid plunge and oscillation of the FOI signal.

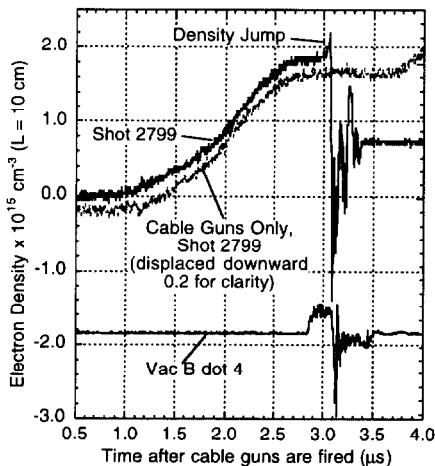

Figure 5. FOI data when Marx bank is fired.

An expanded view of the Vac-Bdot-4 signal, the X-ray data, and the density burst are plotted in Fig. 6 versus the conduction time. Note that the jump and rapid plunge in the FOI signal occur well before both the X-ray burst and switch opening.

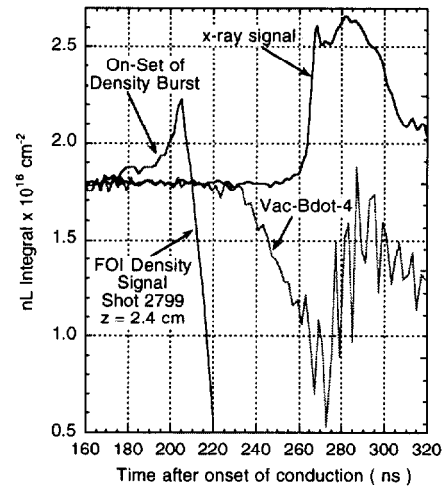

Figure 6. Detail of on-set of density burst.

Figure 7 shows an expanded view of the onset of the density burst at four z locations. The density jump occurs at later times for larger values of z , implying motion of the density burst down the axis of the chamber. Note that prior to the density burst the plasma density falls off with z similar to the cable-gun-only measurements of Fig. 3.

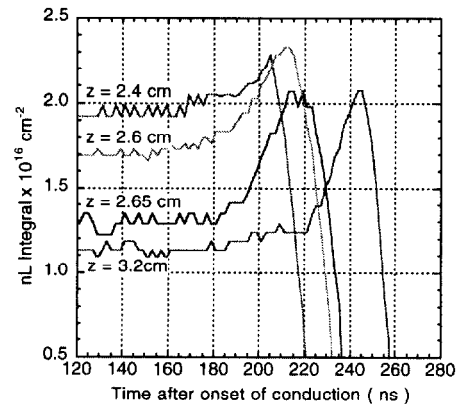

Figure 7. On-set of density burst for different z values.

To support the idea that a burst of plasma travels down the axis of the chamber, measurements were made at $z=8.8$ cm and a typical result is shown in Fig. 8. A clear burst of plasma is observed to arrive at this location, starting at approximately $t \approx 330$ ns after the onset of conduction. To illustrate the motion of the plasma burst, its position is plotted versus time in Fig. 9. The arrival time was determined by extrapolating the initially rising part of each curve back to the time axis (from Figs. 7 and 8). The lower line is a least-squares-fit to the first four data points (the data taken through the window centered at $z=2.8$ cm) and gives $v \approx 25 \text{ cm}/\mu\text{s}$, whereas the upper line is a least-squares-fit to all the data points and gives a velocity of $v \approx 42 \text{ cm}/\mu\text{s}$. The increase in velocity as the burst travels down the chamber axis indicates that the plasma continues to accelerate under the action of the current. An estimate of the Alfvén velocity taking $r=8.0$ cm, $I=1.4$ MA, and $n \approx 5 \times 10^{15} \text{ cm}^{-3}$ gives

$v_A = B/\sqrt{\mu_0 \rho} \approx 31 \text{ cm}/\mu\text{s}$ which is about midway between the measured upper and lower velocities. The typical POS opening time is shown in the figure and implies that the onset of the plasma burst is located at approximately $z \approx 4.2 \text{ cm}$ when opening occurs. This is significant because it demonstrates that all of the physics of opening takes place within about 4 cm of the centerline of the cable guns.

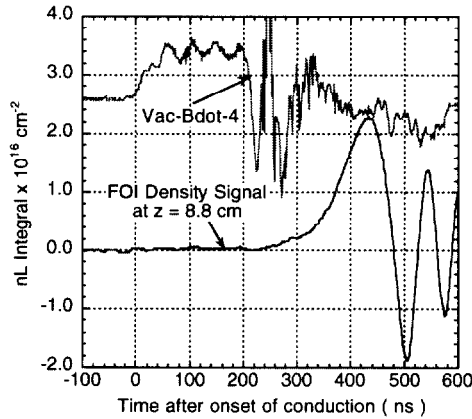

Figure 8. FOI measurement at $z = 8.8 \text{ cm}$.

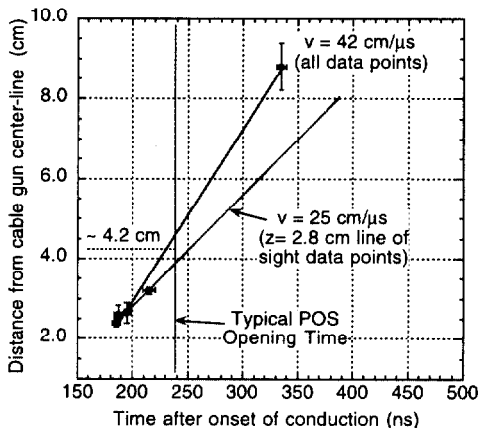

Figure 9. Position of density burst versus time.

As seen in Figs. 5 and 8 the FOI signal undergoes many oscillations after the onset of the density burst. The additional oscillations are due to the interference fringes exceeding $\lambda/4$ of a wavelength and indicate that the density is continuing to rise (the fall off in the amplitude of the fringes is a result of a fall off in the intensity of the transmitted beam through the plasma due to refraction effects). An estimate of the plasma density of the burst can be obtained by counting the number of fringes. From Fig. 5, and other shots taken around $z = 2.8 \text{ cm}$, the maximum number of fringes is determined to be about 4 or 5. This gives an estimate of $n \sim 10^{16} \text{ cm}^{-3}$ assuming that half of the fringes are due to “unwinding” of the FOI signal. It is interesting to note that for the data taken at $z = 8.8 \text{ cm}$ the number of fringes usually exceeds 6 or 7, indicating that the density of the burst increases as it propagates, or alternatively, that additional plasma may be introduced from electrode surfaces at this location.

The spatial width of the density burst can be estimated from its measured velocity and temporal duration. From Fig. 5 the fringes are seen to run-on for about 300 ns. Taking 150 ns (assuming half the signal is unwinding of the fringes) gives an estimate of the width of $w = v\Delta t \approx 3.8 \text{ cm}$, using $v = 25 \text{ cm}/\mu\text{s}$. The width of the initial plasma fill, taking $n \approx 1 \times 10^{15} \text{ cm}^{-3}$ as a reasonable location for the edge, is about 6 cm (from Fig. 4). Thus at $z = 2.8 \text{ cm}$ the density burst is somewhat compressed spatially compared to the initial fill. At $z = 8.8 \text{ cm}$ the fringes typically run-on for $t = 500 \text{ ns}$, again assuming that half of this time is unwinding of the fringes, the width is estimated to be $w = v\Delta t \approx 10 \text{ cm}$, where $v = 42 \text{ cm}/\mu\text{s}$ has been used. The width of the density burst appears to be somewhat narrower at $z = 2.8 \text{ cm}$, which is prior to opening, than it is at $z = 8.8 \text{ cm}$, which is after the switch has opened (as mentioned above, though, additional plasma may be introduced from electrode surfaces at later times). The above analysis assumes that the plasma burst travels only in the axial direction. The actual motion is almost certainly more complex, involving movement in the radial direction as well. During this investigation only a limited field-of-view was available and the beam was not repositioned in the radial direction.

IV. SUMMARY

The first measurements of the plasma in the POS load region of DM1 have been performed. The following conclusions can be drawn:

- The cable guns produce a fill plasma, measured at $z \approx 2.8 \text{ cm}$, $r \approx 8.0 \text{ cm}$, of density $n \approx 1$ to $2 \times 10^{15} \text{ cm}^{-3}$ which falls off rapidly in z . The shot-to-shot variation in the fill plasma is about 10% to 20%.
- The cable gun fill plasma has a transverse velocity of $v_z \sim 1 \text{ cm}/\mu\text{s}$ and is estimated to have a density at $z = 0 \text{ cm}$ of about $n \approx 5 \times 10^{15} \text{ cm}^{-3}$.
- When the Marx bank is fired, a burst of plasma is observed to travel axially toward the diode with velocity $v \approx 25 \text{ cm}/\mu\text{s}$. The velocity of the burst increases with z reaching $v = 42 \text{ cm}/\mu\text{s}$ by $z = 8.8 \text{ cm}$. These velocities are close to the calculated Alfvén velocity, $v_A \approx 31 \text{ cm}/\mu\text{s}$.
- The density of the burst is estimated to be about $n \sim 10^{16} \text{ cm}^{-3}$ and appears to increase somewhat with z .
- The opening of the POS takes place when the burst of plasma has arrived at about $z \approx 4.2 \text{ cm}$.
- The burst of plasma is estimated to have a width of about $w \approx 3.8 \text{ cm}$ at $z = 2.8 \text{ cm}$, prior to opening, and a width of $w \approx 10 \text{ cm}$ at $z = 8.8 \text{ cm}$, after opening.
- Prior to opening, no plasma is observed downstream of the POS ($z = 8.8 \text{ cm}$) greater than about $n_e \approx 1 \times 10^{13} \text{ cm}^{-3}$. This is the minimum detectable level of the FOI assuming $L = 20 \text{ cm}$.

V. REFERENCES

- [1] B.V. Weber, D.D. Hinshelwood, and R.J. Commisso, "Interferometry of Flashboard and Cable-gun Plasma Opening Switches on Hawk," IEEE Trans. of Plasma Science, Vol. 25, No. 2, April 1997.
- [2] J.R. Goyer, D. Kortbawi, F.K. Childers, and P.S. Sincerny, "Low Jitter Operation of a Plasma Opening Switch," J. Appl. Phys., 74 (6), 15 September 1993.

* Work supported by Maxwell Technologies Inc. under subcontract No. 9-114444-001, Defense Special Weapons Agency prime contract DSWA 01-97-C-0169.