

H. Oona, B. G. Anderson, J. C. Cochrane, C. E. Findley,
 J. H. Goforth, A. E. Greene, H. W. Kruse, J. V. Parker, and D. G. Rickel
 Los Alamos National Laboratory
 Los Alamos, New Mexico 87545

Introduction

The aim of the Trailmaster series of experiments is to generate an intense source of soft x-rays by imploding a thin (2000 Å) aluminum cylinder.¹ The present scheme incorporates a plasma flow switch for the final pulse shaping and requires careful diagnostic analysis. The emphasis of this work is to transfer the energy to the load area and to understand the dynamics of the plasma flow switch.² The experiments are carried out at LANL in two facilities. Laboratory experiments that answer questions about the details of the plasma flow switch are done on the 1.5-MJ Pegasus capacitor bank. The higher energy experiments (Procyon series) utilize explosive pulsed power systems and are conducted at the Ancho Canyon firing site. It is the latter set of experiments that will eventually supply an x-ray radiation source at the megajoule level. At the present time, the emphasis of the Procyon experiments is to deliver energy from the generator to the plasma flow switch and the load area. The details of these experiments are given in other papers at this conference.^{3,4}

In order to characterize these experiments one needs to diagnose the driver performance and the dynamics of the plasma and power flow in the plasma flow switch region. The difficulty of experiments in which high current, high voltage, and high explosive are combined, leads to severe problems. Many of the diagnostics are unique and untested. Since only a limited number of experiments are done during a year, the effort is to maximize the information per shot. The aim in this report is to present some of the diagnostic techniques used in the adverse Trailmaster environment.

The Load Region

The vacuum power flow region of the the Procyon experiment is shown in Fig. 1 and it extends from the closing switch to the end of the plasma gun. It includes the anodized radiation baffles, the wire array, the plasma gun, and implosion load region. The switch plasma is generated by the wire array as current is transferred from the generator to the wires and the JXB forces move it along the annular gun barrel to the implosion load. The wire array and the barrier film combination produces 150 mg of switch plasma. The wire array is an intricate weaving of 2-mil-diam aluminum wires as shown in Fig. 3 and is designed to give a $1/R^2$ mass dependence, R represents the radial distance from the center of the plasma gun. The present series of Procyon experiments has not included the cylindrical load foil because the goal is to successfully transfer the power to the load area as described in other papers.^{1,2,3}

The radiation baffles were tested to minimize the probability of radiation-induced flashover at the vacuum dielectric interface. Also, the radiation characteristics of the baffles need to be known for modifications and optimization of the power flow to the load. Flashover for teflon, which is used for a dielectric interface, occurs at $60 \mu\text{J}/\text{cm}^2$.⁵ We have measured transmission with a pulsed xenon (600-J) lamp and an optical multichannel analyzer (OMA). This has shown attenuation of around 10^7 so about $10 \mu\text{J}$ of spectrally integrated radiation in the range of 300 to 600 nm gets to the dielectric vacuum interface. This level of radiation is acceptable and no problems were observed in the Procyon experiments. Flashover is also a function of the spectral distribution or the temperature of the plasma produced by the wire array. In the latest Procyon experiment the plasma temperature of the of the wire array was measured just

after the wires burst. The temperature was determined from a spectral fit to the blackbody distribution to be about 5 ev.

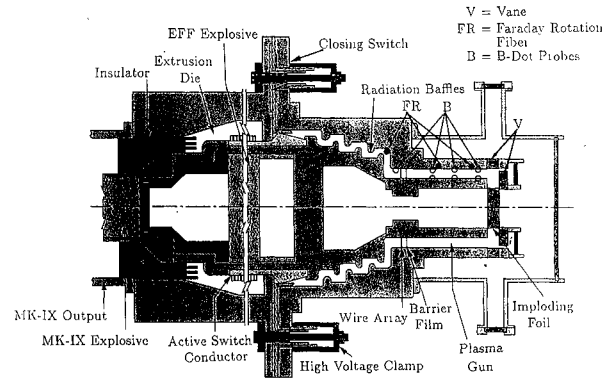

Fig. 1. The components of the Procyon experiment. The radiation baffles, wire array, and barrier foil along with the implosion load area are shown. The location B and Faraday rotation probes are indicated.

Power Flow Diagnostics

Several diagnostic techniques are used to measure the the power flow to the load end of the experiment. Current is measured with Rogowski coils, Faraday rotation systems, and B probes. The Rogowski and B data are transferred over fiber-optic links that have been instrumental in minimizing ground loops. The Faraday rotation systems are intrinsically free of electronic noise but have suffered from mechanical shocks, which are the main cause of data loss with Faraday rotation systems. We rely heavily on accurate current measurements with both Rogowski coils and Faraday rotation systems and correlate the data against each other. Even though B probes can be used to measure currents, they measure localized fields and are affected by plasmas and, therefore, are mainly used for plasma velocity and thickness measurements. We normalize the B data to appropriately located Rogowski and Faraday rotation sensor data and use the information to deduce the amount of current flowing and switched in the plasma flow switch. In the plasma flow switch experiments, a series of B probes are placed along the outside and inside electrodes of the switch channel as shown in Figs. 1 and 2, and they record the arrival time of the plasma as each probe registers the current as the plasma passes.

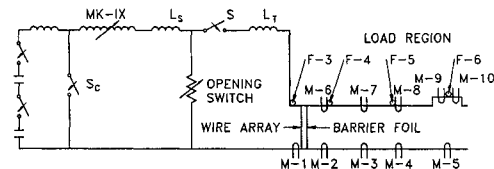

Fig. 2. The electrical circuit for the Procyon experiment. The generator, closing and opening switches are shown. The plasma gun and load area are shown to indicate the positions of the sensors. The plasma position is detected by B probes as it passes the sensor.

The B probes are fabricated from solid copper coax cable with the center wire made into a loop and soldered to the outer copper shell. The area of the loops are approximately $1-3 \times 10^{-6} \text{ m}^2$. The B loop is embedded in epoxy inside a fused silica tube. These probes are extremely rugged and work

*This work was supported by the US Department of Energy.

Report Documentation Page

Form Approved
OMB No. 0704-0188

Public reporting burden for the collection of information is estimated to average 1 hour per response, including the time for reviewing instructions, searching existing data sources, gathering and maintaining the data needed, and completing and reviewing the collection of information. Send comments regarding this burden estimate or any other aspect of this collection of information, including suggestions for reducing this burden, to Washington Headquarters Services, Directorate for Information Operations and Reports, 1215 Jefferson Davis Highway, Suite 1204, Arlington VA 22202-4302. Respondents should be aware that notwithstanding any other provision of law, no person shall be subject to a penalty for failing to comply with a collection of information if it does not display a currently valid OMB control number.

| | | | | | |
|--|------------------------------------|--|----------------------------|---------------------|---------------------------------|
| 1. REPORT DATE JUN 1991 | 2. REPORT TYPE N/A | 3. DATES COVERED - | | | |
| 4. TITLE AND SUBTITLE Plasma And Electrical Diagnostics For Procyon Experiments | | 5a. CONTRACT NUMBER | | | |
| | | 5b. GRANT NUMBER | | | |
| | | 5c. PROGRAM ELEMENT NUMBER | | | |
| 6. AUTHOR(S) | | 5d. PROJECT NUMBER | | | |
| | | 5e. TASK NUMBER | | | |
| | | 5f. WORK UNIT NUMBER | | | |
| 7. PERFORMING ORGANIZATION NAME(S) AND ADDRESS(ES) Los Alamos National Laboratory Los Alamos, New Mexico 87545 | | 8. PERFORMING ORGANIZATION REPORT NUMBER | | | |
| 9. SPONSORING/MONITORING AGENCY NAME(S) AND ADDRESS(ES) | | 10. SPONSOR/MONITOR'S ACRONYM(S) | | | |
| | | 11. SPONSOR/MONITOR'S REPORT NUMBER(S) | | | |
| 12. DISTRIBUTION/AVAILABILITY STATEMENT Approved for public release, distribution unlimited | | | | | |
| 13. SUPPLEMENTARY NOTES See also ADM002371. 2013 IEEE Pulsed Power Conference, Digest of Technical Papers 1976-2013, and Abstracts of the 2013 IEEE International Conference on Plasma Science. Held in San Francisco, CA on 16-21 June 2013. U.S. Government or Federal Purpose Rights License | | | | | |
| 14. ABSTRACT The aim of the Trailmaster series of experiments is to generate an intense source of soft x-rays by imploding a thin (2000 A) aluminum cylinder.1 The present scheme incorporates a plasma flow switch for the final pulse shaping and requires careful diagnostic analysis. The emphasis of this work is to transfer the energy to the load area and to understand the dynamics of the plasma flow switch.2 The experiments are carried out at LANL in two facilities. Laboratory experiments that answer questions about the details of the plasma flow switch are done on the 1.5-MJ Pegasus capacitor bank. The higher energy experiments (Procyon series) utilize explosive pulsed power systems and are conducted at the Ancho Canyon firing site. It is the latter set of experiments that will eventually supply an xray radiation source at the megajoule level. At the present time, the emphasis of the Procyon experiments is to deliver energy from the generator to the plasma flow switch and the load area. The details of these experiments are given in other papers at this conference. 3 &4 | | | | | |
| 15. SUBJECT TERMS | | | | | |
| 16. SECURITY CLASSIFICATION OF: | | | 17. LIMITATION OF ABSTRACT | 18. NUMBER OF PAGES | 19a. NAME OF RESPONSIBLE PERSON |
| a. REPORT unclassified | b. ABSTRACT unclassified | c. THIS PAGE unclassified | SAR | 4 | |

well in our environment. Each probe is calibrated by referencing it to a known loop area with a pulsed current source and in this manner the effective loop areas are determined for each one.

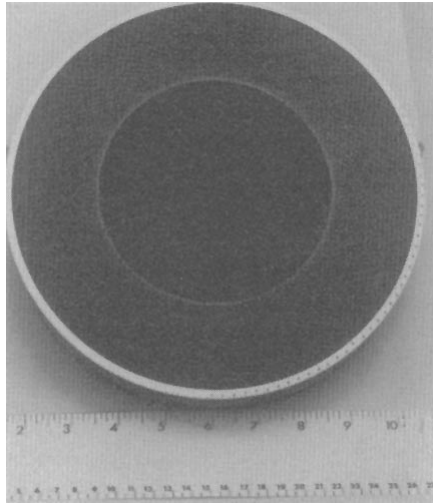

Fig. 3. The wire array. This is the source for the plasma in the plasma flow switch. The pattern is to simulate a $1/R^2$ mass dependence. The angle, wire size, and the angular step size of the wire positions determine the mass dependence.

Figure 4a shows integrated \dot{B} data for the probes on the outside plasma channel wall and Fig. 4b shows data for the inside wall. The data for the load region are also included in Fig. 4b for one of the Procyon experiments. The probe data for the outside wall have been normalized to the current that was observed above the wire array with the Rogowski coils and Faraday rotation probes. We can determine the plasma velocity from this data by observing the time of the initial rapid signal onset for each probe. The velocity of the switch plasma determined in this manner is $2 \text{ cm}/\mu\text{s}$ between probes m-2 and m-3 and $5.2 \text{ cm}/\mu\text{s}$ between probes m-3 and m-5 and the plasma thickness was estimated to be a maximum of $\sim 5 \text{ cm}$ by the time it reaches the load region. The same analysis was done for the data from the inside wall of the gun barrel and the load area. We find, for the probes at their conjugate locations, the velocity to be $2 \text{ cm}/\mu\text{s}$ and $4.8 \text{ cm}/\mu\text{s}$, respectively. The plasma, therefore, moved in the barrel as a reasonably uniform annular "washer." Also, we notice that the current switching to the load area, as indicated by probes m-9 and m-10 was simultaneous but small, and not the same magnitude. The Faraday rotation signals in Fig. 5 also show lower currents (significantly less than 100%) in the load, but still higher than the \dot{B} probes indicate. The Faraday rotation probes do not reach peak current and are probably affected by either mechanical damage or intense radiation that modifies the characteristics of the fiber. Even though the Faraday probes are more accurate and not plagued by local plasma anomalies, they are, nevertheless, subject to changes in birefringence caused by mechanical effects.

Faraday rotation field sensors are extremely valuable where ground loops and electrical noise can severely distort the data. Figure 6 illustrates the system used at LANL for the Procyon experiments. The fibers in the experimental setups are protected by plastic tubing, RTV, Torr seal, or other epoxies, which provide protection from shocks and UV light. A beam of linearly polarized HeNe (632.8 nm) light is transmitted through the sensor to a recording station where the rotation of the plane of polarization is measured. Half-wave retardation plates are used to rotate the polarization direction at the fiber entrance and at the analyzer. Following development by others,⁶ the Faraday rotation angle Θ for a coaxial geometry is $\Theta = V' \int_0^L B \cdot dx$. V' is the Verdet constant for the material, B is the magnetic field strength, and L is the path length in the field. According to Amperes law, $I = (1/\mu_0) \int B \cdot dx$, and

here I is the current crossing the surface bounded by the line integral and, therefore, $\Theta = V' \mu_0 I$. A result from the shot is given in Fig. 7 and it is obvious that the fringes are reasonably easy to count early in time but at late times when rapid current changes are taking place and where current reversals are encountered the situation gets difficult. Usually, two detectors are set to record the same signal with a 90-phase difference. The resulting signal will be quadrature coded, making possible the detection of signal reversals.

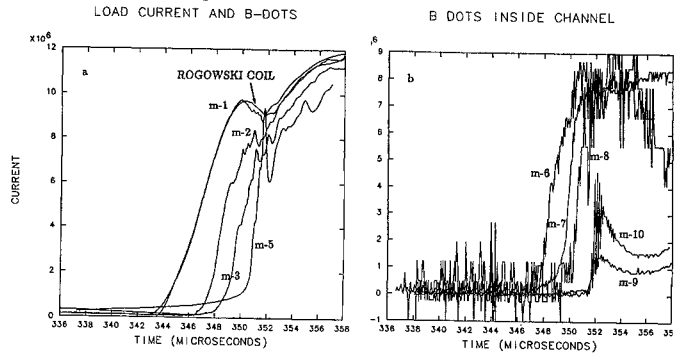

Fig. 4. a) The \dot{B} data from the probes on the outside channel. Signals are observed as the plasma passes the probes. The probes currents are normalized to Rogowski coil data. The \dot{B} probes are mainly used for plasma velocity measurements and thickness. The velocity is determined from the probe location and the sudden onset of probe current. b) The \dot{B} data from the inside wall of the plasma-flow switch. The data are normalized to data from the outside wall. The onset times from both data sets indicate the the annular plasma was a reasonably uniform "washer."

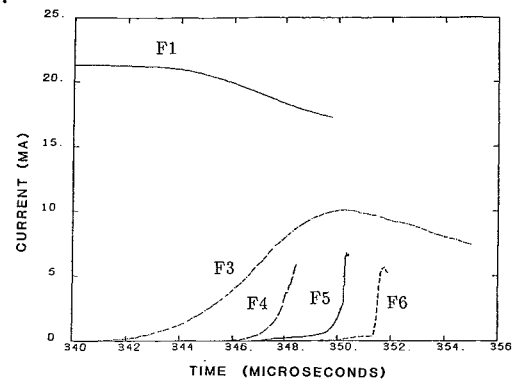

Fig. 5. Faraday rotation signals for Procyon experiment (PSS3). The generator and plasma-flow switch currents are shown. F-1 shows the generator current. F-3 is the current measured at the radiation baffles. The current in the plasma gun and load area are given by F-4, F-5, and F-6. F-6 shows the current that is switched into the load.

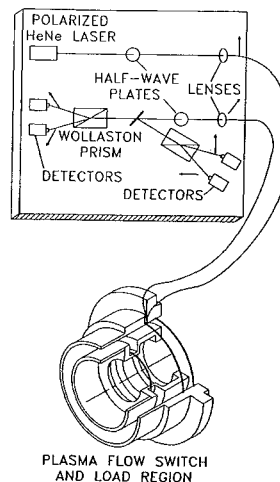

Fig. 6. The Faraday rotation system on the plasma-flow switch. The optics and the load region are shown. A HeNe laser transmits polarized light that encircles the current path. Half-wave plates at the entrance and exit of the fiber align the polarization. The Wollaston prisms are used to provide measurements of both the sine and cosine of the rotation angle.

The sensitivity of the fiber is determined by the Verdet constant and for most of our experiments this sensitivity is 0.6818 MA/cycle, i.e., the polarization changes through one cycle as the current changes 0.6818 MA. For accurate current measurements of less than 1 MA, the number of fiber turns are increased, and in some cases up to 50 turns have been used with a sensitivity of 0.014 MA/cycle. In cases where the magnetic field changes very rapidly, a lower sensitivity may be desirable and we have used systems with a different laser wavelength (850 nm) to give a sensitivity of 1.15 MA/cycle.

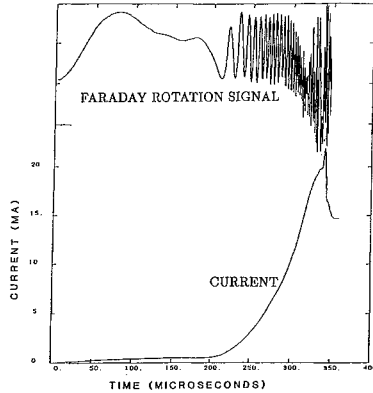

Fig. 7. Example of Faraday rotation signal from a Procyon experiment. The top curve shows the Faraday rotation signal. The bottom curve shows current. The fringes are counted and multiplied by the Verdet constant to give the current. For rapidly changing currents the resolution is changed so that fringes can be counted.

Radiation Diagnostics

Even though the emphasis of the Procyon series of experiments has been to transfer power to the load region, the requirement to diagnose the radiation from the up-coming foil implosion tests needs to be addressed. The generator and switch in these experiments are explosively driven and the vacuum implosion chamber and the diagnostics do not survive the blast. Radiation comes from the plasma flow switch and from the foil implosion region. It is necessary to monitor different phases of each process. In the plasma flow switch we desire to monitor the initiation of the wire array and the subsequent motion of the plasma down the gun barrel. During the foil implosion process we need to monitor the initiation of the load foil, the run-in, and thermalization. The diagnostics for these experiments include filtered x-ray diodes, filtered bolometers, time-resolved imaging cameras, time-resolved, uv-visible and x-ray spectrometers, and pinhole cameras. In this paper we will discuss some of these techniques and show data obtained from Pegasus and other related experiments.

Visible imaging has been done with two different types of cameras: the high-pressure, gas-driven rotating mirror cameras; and the electronic high-speed cameras (Imacons). Mirrors are used to transfer the image from the experiment to screen rooms or to bunkers. The optical path, which is usually less than 100 ft, views the plasma both axially and radially. Figures 9-10 are Imacon pictures that reveal some features of the plasma on plasma flow switch experiments at the Pegasus capacitor bank.

In Fig. 8a we observe the plasma sheath as it passes the load area. The inter-frame time of each image is 167 ns and the actual exposure time is 20% of this. The velocity and thickness of the sheath can be estimated from these images. We estimate a velocity of a minimum 6 cm/ μ s and a thickness of about 1.5 cm, and this information is very important input for the theoretical design codes. After careful examination of the images it becomes evident that a precursor plasma appears early in time. This feature has been observed with B probes as early current in all the plasma flow switch experiments. Figures 8a and 8b show an implosion as observed axially in the load region. An implosion is clearly observed with a framing camera in Fig. 8b as the plasma collapses on the axis. The pattern observed is due to a slot pattern in the electrical glide plane at the end of the load region. The interframe time in this experiment is 100 ns. Similarly, an implosion is observed with a streak camera (Fig. 8c) as the plasma moves toward the axis

and the light from the plasma generates a parabolic shape as it accelerates to its collapse. Estimates of the final implosion velocity from the streak camera data were 18 cm/ μ s.

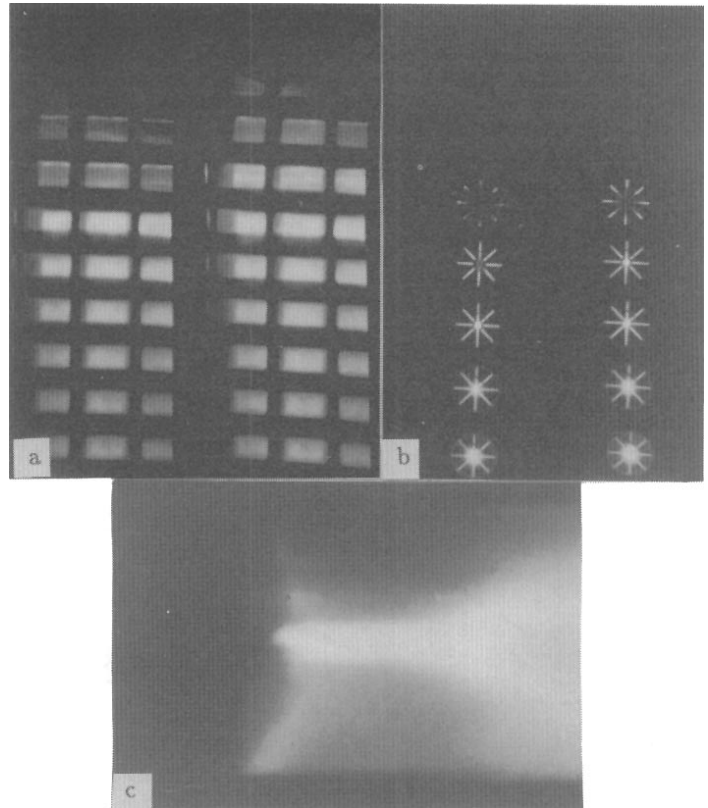

Fig. 8. a) Radial view of plasma on Pegasus capacitor bank experiment. The images shown are taken 167 ns apart and exposure time is about 34 ns. The timing alternates from left to right and down. The plasma moves up in each image. We notice early in time the front edge of a precursor and a series of waves of plasma. The main plasma is observed as the bright images during several frames. Estimates of the plasma velocity were 6 cm/ μ s and a thickness of 1.5 cm. b) Axial view of a plasma pinch in the load area. The pattern is due to a slotted electrical glide plane. It is clear when plasma reaches the center. Interframe time in this figure is 100 ns. c) A streak camera picture of a pinch. As the plasma implodes and accelerates, a parabolic image is observed. Late in time the plasma begins to expand. At pinch time the plasma velocity was calculated to be about 18 cm/ μ s.

X-ray imaging and spectroscopy diagnostics are difficult to field in the adverse environments. These diagnostics need to be located in the vacuum system and in the vicinity of high explosives and, therefore, need to be fabricated in such a way that they can withstand the explosive shocks and be recoverable. Film is the main recording medium for these instruments. After the experiment, these diagnostics need to be recovered and film processed. Figure 9 shows an x-ray pinhole camera spectrometer combination that has been successfully used. This camera is built inside a one-in.-thick steel casing, is vacuum tight, and reusable. Filters are used in front of the pinholes to transmit only x-rays. A shutter mechanism (either spring loaded or detonator driven) blocks stray light after the experiment and prior to recovery. Figure 10a shows the raw data of an x-ray pinch from the Laguna experiments. Image enhancement has improved the pinch region in the photograph as seen in Fig. 10b and a computer determined density profile is shown in Fig. 10c. In this picture the dimension of the main "blob" of the pinch is 2-mm wide with a height of about 17 mm.

There is a need to measure the temperature of the implosion at pinch time. For this purpose filtered x-ray diodes (XRD) and bolometers are used and the data fitted to a Planckian

(black body) distribution. The bolometers used in the Trailmaster experiments are modified versions that were originally developed at AFWL⁷ and at Sandia Laboratories.⁸ The one used at LANL is a four channel filtered system. The filters and detector foil are chosen based on the experimental conditions (approximate temperature). In most of our experiments, the detector foil is 1- μm -thick nickel mounted on a fused silica substrate. The bolometer is biased with 40 A about 8 μs prior to the critical event (pinch). When radiation hits the bolometer foil the temperature of the foil and, therefore, the resistance is changed. This resistance change, along with the current flow in the foil, generates a voltage that is related to the energy deposited in the foil. On one of the latest plasma switch Pegasus experiments we obtained 19.2-kJ total energy deposited into 4- π steradians in this experiment. The spectral range of the bolometer covers from about 70 eV to 3 keV. The differentiated data gives the power for the implosion. The peak power was 5×10^{10} W.

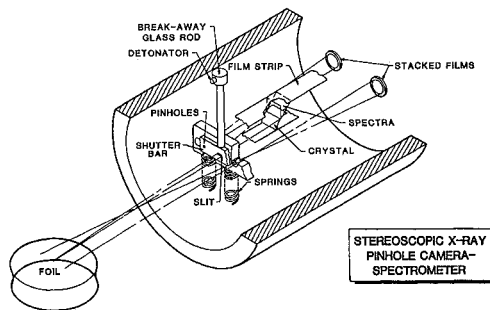

Fig. 9. The x-ray pinhole camera/spectrometer combination. This camera has been re-used in several experiments. The two images can give a stereoscopic picture of the pinch or they can be used with different filtering. The spectrometer is designed to be usable with a variety of x-ray crystals. A shutter mechanism closes the system to stray light after the experiment.

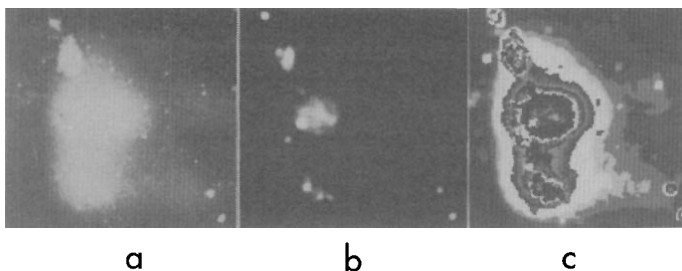

Fig. 10. Images taken with the x-ray camera. a) shows the raw data. b) is a computer-enhanced image to show the position of the pinch. c) shows a density profile. The size of the pinch determined from these figures is about 2-mm wide by about 17-mm high.

The sensitivity of the bolometer is a function of the detector foil material, size, current through the foil, and resistivity change with specific energy. This is given by $\Delta V/F_a = I(\Delta\rho/\Delta\varepsilon)(1/\nu x^2)(l/w)$ where ΔV is the increase of resistive voltage, I is the bolometer bias current, $\Delta\rho/\Delta\varepsilon = (\partial\rho/\partial T)/(\partial\varepsilon/\partial T)$ is the resistivity change with specific energy, ν is the foil mass density, x is the foil thickness, l and w are the exposed dimensions of the foil, and F_a is the absorbed radiation fluence (J/cm^2) after being corrected for filter transmission. The time response of these bolometers is less than 5 ns and they have

a useful range of fluences from 1×10^{-3} to 1×10^{-1} J/cm^2 . They can operate at fluences up to the point where the foil begins to ablate.

Conclusions

Over a time period of several years numerous diagnostic techniques have been developed and modified to address different phases of the Trailmaster program. We have demonstrated that the diagnostic techniques can be successfully fielded in the adverse environments. Other diagnostic developments are in progress including time-resolved, high-resolution x-ray spectroscopy and imaging. Improvements are being made in electrical diagnostics and the increased use of fiber optic links has significantly enhanced the quality of the electrical data. Noise pickup and ground loop problems encountered on previous experiments have virtually been eliminated.

Acknowledgements

We wish to give special commendation to Vivian Gurule for her infinite patience in fabricating the intricate wire arrays and the B probes. Many thanks go to Dennis Herrera and the Pegasus crew with the help for the successful Procyon experiments. Also, special thanks must be given to Janet Neff for the excellent typing and preparation of this manuscript.

References

- [1] W. L. Baker, G. Bird, J. S. Buff, C. Boyer, C. J. Clouse, S. K. Coffey, D. Conte, D. W. Conley, J. F. Davis, J. H. Degnan, D. Dietz, M. F. Frese, J. D. Graham, S. L. Gonzalez, K. E. Hackett, D. J. Hall, J. L. Holmes, E. A. Lopez, W. F. McCullough, R. E. Peterkin, D. W. Price, R. E. Reinovsky, N. F. Roderick, S. Seiler, P. J. Turchi, S.W.R. Warren, and J. M. Welby, "Multi-Megampere Plasma Flow Switch Driven Liner Implosions," in *Megagauss Technology and Pulsed Power Applications*, C. M. Fowler, R. S. Caird, and D. J. Erickson, eds. Plenum Press, pp. 653-662, 1986.
- [2] A. E. Greene, R. L. Bowers, J. H. Brownell, J. H. Goforth, H. Oona, D. L. Peterson, D. G. Rickel, and D. L. Weiss, "Computational Modeling of the Trailmaster Procyon System," this conference.
- [3] J. H. Goforth, H. Oona, J. H. Brownell, A. E. Greene, H. W. Kruse, I. R. Lindemuth, S. P. Marsh, J. V. Parker, R. E. Reinovsky, D. G. Rickel, and P. J. Turchi, "Procyon Experiments Utilizing Explosively-Formed Fuse Opening Switches," this conference.
- [4] D. G. Rickel, I. R. Lindemuth, R. E. Reinovsky, J. H. Goforth, A. E. Greene, H. W. Kruse, H. Oona, J. V. Parker, and P. J. Turchi, "Procyon Experiment Utilizing Foil-Fuse Opening Switches," this conference.
- [5] C. L. Enloe and R. M. Gilgenbach, "Microscopic and Macroscopic Material Property Effects on Ultraviolet-Laser-Induced Flashover of Angled Insulators in Vacuum," *IEEE Transactions on Plasma Science*, Vol. 16, No. 3, June 1988.
- [6] L. R. Veaser, R. S. Caird, C. M. Fowler, and D. J. Erickson, "A Fiber Optic Sensor for Measuring Multimegampere Currents From Flux Compression Generators," in *Proceedings of SPIE - The International Society for Optical Engineering*, Vol. 506 (1984).
- [7] James H. Degnan, "Fast, Large-Signal, Free-Standing Foil Bolometer for Measuring Ultrasoft X-Ray Burst Fluence," *Rev. Sci. Instrum.* **50**(10), October 1979.
- [8] Private communication with David Hanson at Sandia National Laboratories.