

A MODEL FOR THE MAGNETIC CORES OF LINEAR INDUCTION ACCELERATOR CELLS

J.G.Melton and E.A.Rose
Los Alamos National Laboratory
Los Alamos, New Mexico 87545

Abstract

Linear induction cells are used in the electron beam accelerator for the proposed Dual Axis Radiographic Hydrotest (DARHT) facility that would be built at Los Alamos National Laboratory. Ferrite cores are used in each cell to produce 250 kV, flat to within $\pm 1\%$ for 70 ns. In the course of operating a prototype test stand for the full accelerator, circuit models have been developed for the pulsed power system and the induction cells that have been useful in achieving the $\pm 1\%$ flatness requirement. The circuit models use the MicroCap IV™ electronic circuit analysis program, which includes a Jiles-Atherton model for magnetic materials. In addition, the coaxial, ferrite-filled geometry of the cell is modelled by a multiple-section lumped-element transmission line. Propagation of a voltage pulse through the ferrite cores, including saturation effects, can be reproduced. The model has been compared to actual waveforms obtained from prototype operations, and good results have been obtained for a wide range of operating conditions. Interest in possible future applications have led us to use the model to predict the behavior of accelerator cells driven by multiple voltage pulses without an intervening magnetic reset of the ferrite cores. Results show that multiple pulses can be applied to the accelerator cells without a magnetic reset, but with some degradation of later pulses. The degradation appears as a droop on the flat portion of the second (and subsequent) pulses. The droop can be corrected by shaping the waveform of the incident pulses.

Introduction

Should the U.S. DOE decide to complete the facility, DARHT would use two 16-20 Mev linear induction accelerators to supply electron beam currents of 3 kA to a radiographic source target. To produce high quality radiographic images requires that the beams be focussed to a very small size, approximately 1 mm diameter. This in turn requires that the accelerating voltages of the induction cells be uniform to within $\pm 1\%$ for the greater part of the voltage pulse. To achieve this level of accuracy, circuit models have been developed to describe the operation of the cells.

One of the most important circuit elements to be modelled is the magnetic material used in the induction cells to couple the applied voltage to the accelerating gap. The magnetizing current that flows in the material both before and during saturation has a strong effect on the cell voltage. The behavior of the material can affect the waveforms in more subtle ways, as well, and accurate modeling requires including not only saturation effects, but hysteresis and wave propagation effects also.

We have developed a model for the induction cells using commercially available SPICE based programs, which have a built-in magnetic core circuit element based on the Jiles-Atherton¹ model for magnetic materials. The model includes both hysteresis effects and saturation effects. We include wave propagation effects by using multiple-section lumped-element delay lines. First, magnetic parameters in the core models are trimmed to match experimental waveforms obtained from tests of a single ferrite core. Then, circuit parameters of the multiple-section line are trimmed to match experimental data obtained from the prototype induction cells. Once the parameters have been adjusted to match the waveforms at one operating voltage, the same parameters achieve a reasonable fit to the waveforms

Report Documentation Page

Form Approved
OMB No. 0704-0188

Public reporting burden for the collection of information is estimated to average 1 hour per response, including the time for reviewing instructions, searching existing data sources, gathering and maintaining the data needed, and completing and reviewing the collection of information. Send comments regarding this burden estimate or any other aspect of this collection of information, including suggestions for reducing this burden, to Washington Headquarters Services, Directorate for Information Operations and Reports, 1215 Jefferson Davis Highway, Suite 1204, Arlington VA 22202-4302. Respondents should be aware that notwithstanding any other provision of law, no person shall be subject to a penalty for failing to comply with a collection of information if it does not display a currently valid OMB control number.

1. REPORT DATE JUL 1995	2. REPORT TYPE N/A	3. DATES COVERED -			
4. TITLE AND SUBTITLE A Model For The Magnetic Cores Of Linear Induction Accelerator Cells		5a. CONTRACT NUMBER			
		5b. GRANT NUMBER			
		5c. PROGRAM ELEMENT NUMBER			
6. AUTHOR(S)		5d. PROJECT NUMBER			
		5e. TASK NUMBER			
		5f. WORK UNIT NUMBER			
7. PERFORMING ORGANIZATION NAME(S) AND ADDRESS(ES) Los Alamos National Laboratory Los Alamos, New Mexico 87545		8. PERFORMING ORGANIZATION REPORT NUMBER			
9. SPONSORING/MONITORING AGENCY NAME(S) AND ADDRESS(ES)		10. SPONSOR/MONITOR'S ACRONYM(S)			
		11. SPONSOR/MONITOR'S REPORT NUMBER(S)			
12. DISTRIBUTION/AVAILABILITY STATEMENT Approved for public release, distribution unlimited					
13. SUPPLEMENTARY NOTES See also ADM002371. 2013 IEEE Pulsed Power Conference, Digest of Technical Papers 1976-2013, and Abstracts of the 2013 IEEE International Conference on Plasma Science. Held in San Francisco, CA on 16-21 June 2013. U.S. Government or Federal Purpose Rights License.					
14. ABSTRACT Linear induction cells are used in the electron beam accelerator for the proposed Dual Axis Radiographic Hydrotest (DARHT) facility that would be built at Los Alamos National Laboratory. Ferrite cores are used in each cell to produce 250 kV, flat to within $\pm 1\%$ for 70 ns. In the course of operating a prototype test stand for the full accelerator, circuit models have been developed for the pulsed power system and the induction cells that have been useful in achieving the $\pm 1\%$ flatness requirement. The circuit models use the MicroCap IV electronic circuit analysis program, which includes a Jiles-Atherton model for magnetic materials. In addition, the coaxial, ferrite-filled geometry of the cell is modelled by a multiplexsection lumped-element transmission line. Propagation of a voltage pulse through the ferrite cores, including saturation effects, can be reproduced. The model has been compared to actual waveforms obtained from prototype operations, and good results have been obtained for a wide range of operating conditions. Interest in possible future applications have led us to use the model to predict the behavior of accelerator cells driven by multiple voltage pulses without an intervening magnetic reset of the ferrite cores. Results show that multiple pulses can be applied to the accelerator cells without a magnetic reset, but with some degradation of later pulses. The degradation appears as a droop on the flat portion of the second (and subsequent) pulses. The droop can be corrected by shaping the waveform of the incident pulses.					
15. SUBJECT TERMS					
16. SECURITY CLASSIFICATION OF:			17. LIMITATION OF ABSTRACT	18. NUMBER OF PAGES	19a. NAME OF RESPONSIBLE PERSON
a. REPORT unclassified	b. ABSTRACT unclassified	c. THIS PAGE unclassified	SAR	6	

at other operating voltages.

The model can be used to investigate other interesting effects. In this paper, we describe an investigation of what would happen if two successive voltage pulses were applied to an induction cell, without applying an intervening reset pulse.

Model Description

Figure 1 shows a cross sectional view of a linear induction cell designed for the proposed DARHT accelerators. The cells are 43.2 cm long (gap to gap) and the beam tube radius is 7.4 cm. A 250 kV voltage pulse is applied to each 1.9 cm accelerating gap for approximately 100 ns, with a flat-top time of 70-80 ns. The voltage pulse is supplied from a water-insulated Blumlein through two coax cables that connect to the induction cell at the horizontal mid-plane.

The cavity of the cell contains 11 ferrite cores of PE-16 material. They provide a total of 0.023 volt-seconds of flux swing when pulsed from a negative remnant field of 0.3 Tesla to positive saturation at 0.33 Tesla. The same pulsed current that is used to charge the Blumlein prior to a shot provides the magnetic reset of the cores.

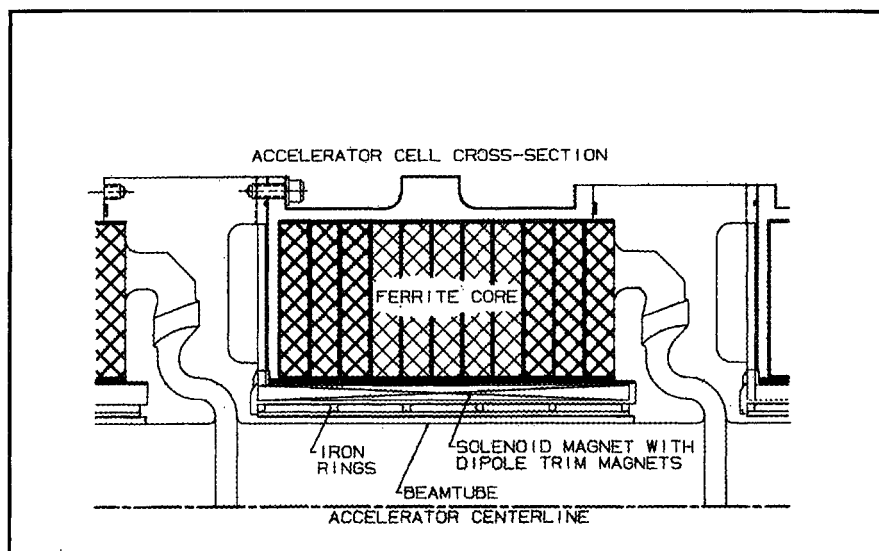

Figure 1. Cross section of induction cell.

It is very important that circuit models include the effects of saturation of the magnetic material. It is somewhat less important that they include the effects of magnetic hysteresis. A successful model for magnetic effects, including both saturation and hysteresis, has been developed by Jiles and Atherton (J-A). It has been incorporated into commercially available SPICE based circuit analysis programs. In addition to modeling the outer B-H loop, the J-A model is capable of modeling internal B-H loops. We have used one of these programs² as the vehicle of our modeling, in order to take advantage of this capability.

Figure 2 shows a comparison of a B-H curve generated by the J-A core model, and an actual experimentally measured B-H curve for a single PE-16 ferrite core. It can be seen that the core model can be adjusted to match the experimental data fairly closely, but that there are some discrepancies which are inherent in the model. In particular, when trying to model very square B-H loops, the J-A model displays a sharp inflection point at the zero crossings of the current, which is not present in the

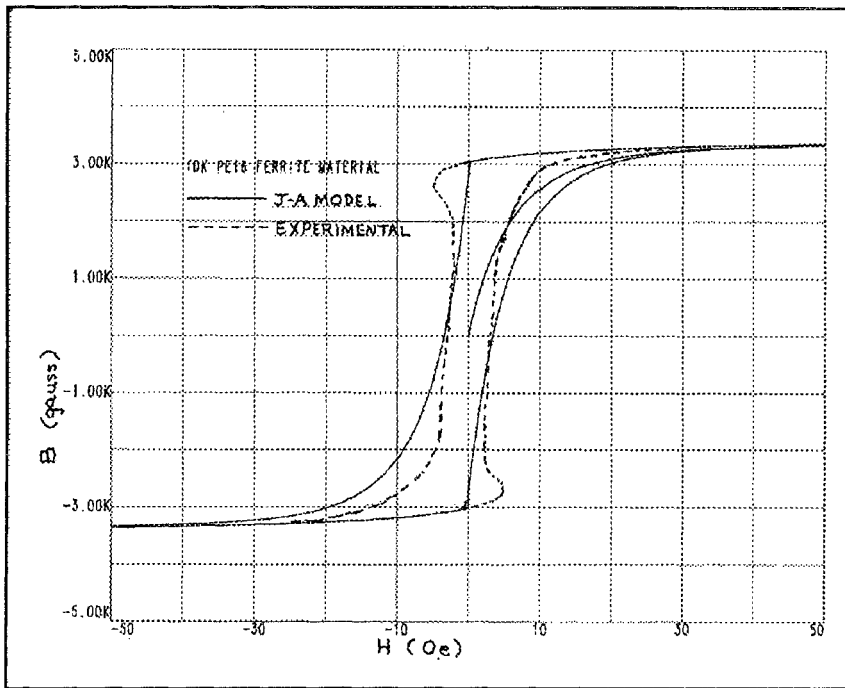

Figure 2. Comparison of B-H curve used in simulation model and actual experimental curve.

experimental data.

In addition to the magnetic effects, it is important to include the wave-like penetration time into the magnetic material. The ferrite cores have a high magnetic permeability μ , and a high permittivity ϵ as well. Typical relative values are $\mu=400$ and $\epsilon=13$. The phase velocity in the material is about 1/70th the speed of light. For these numbers, a single transit time through the ferrite cavity would be about 70 ns. Hence, for a voltage pulse of 100ns, we expect transit time effects to be manifest. To simulate these effects, a multiple-section lumped constant delay line is used, as shown in Fig. 3. Eleven sections are used because the cells contain 11 ferrite cores, and it may be necessary to model core-to-core variations or anomalies.

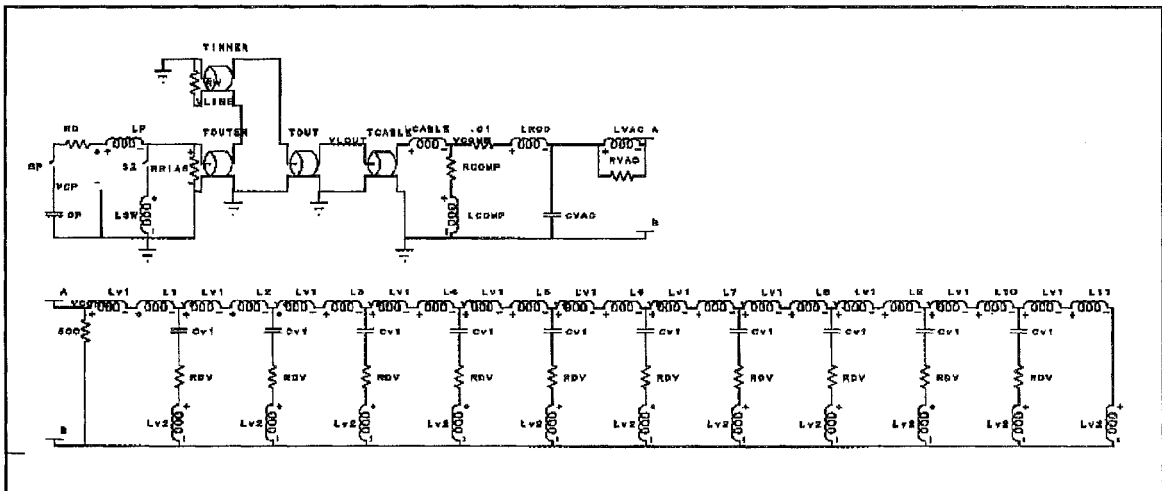

Figure 3. Circuit diagram for induction cell, showing multiple-section line model.

Matching Cell Model to Experimental Data

The circuit parameters used in the cell model have been trimmed to match experimental data from the prototype induction cells. The capacitance per section in the circuit is estimated from the coaxial capacitance of the ferrite cavity, calculated with a dielectric constant of 13. The inductance per section is estimated from the coaxial vacuum inductance of the ferrite cavity. A magnetic core element, representing a single ferrite core, is included in each section. Additional resistive elements have been included to damp oscillations that occur in the model when core elements saturate. To our knowledge, these elements have no known physical basis.

Figure 4 shows typical experimental cell voltage and cell current waveforms, at several different discharge voltages, that we attempt to match with the circuit simulations. The effects of saturation can clearly be seen, as the voltage pulse duration becomes shorter at higher voltages. At the lower voltages, the length of the pulse is not enough to saturate the cores. Effects of hysteresis and time-delay are not obvious from these waveforms.

Attempts to simulate the waveforms using a single-section core model were moderately successful, since a single-section model includes both saturation and hysteresis. However, significant improvement was obtained by adopting the multiple-section delay line of Fig. 3 for the ferrites. Computed voltages and currents from the multiple-section line can be seen in Fig. 5. The overall features of the waveforms are reproduced quite well. The voltage waveforms agree better than the current waveforms. The computed currents do not reach as high a peak current after saturation as the experimental currents. This is a result of the assumed form for the B-H curve in the core model, due to difficulty in matching all portions of the B-H curve with the equations of the Jiles-Atherton model (see Fig. 2). Later in time, reflections of the pulses become more important and the agreement for both waveforms becomes worse.

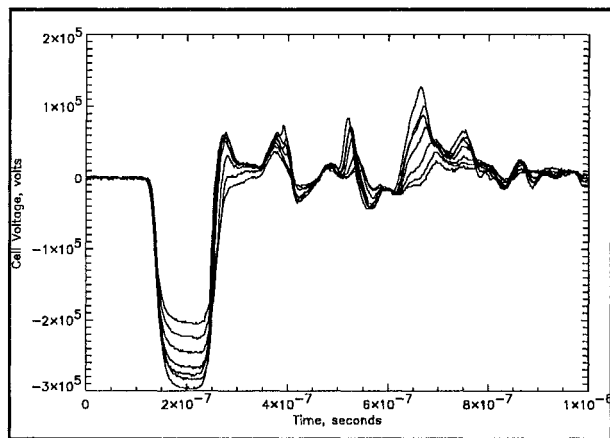

Figure 4(a) Experimental cell voltage waveforms.

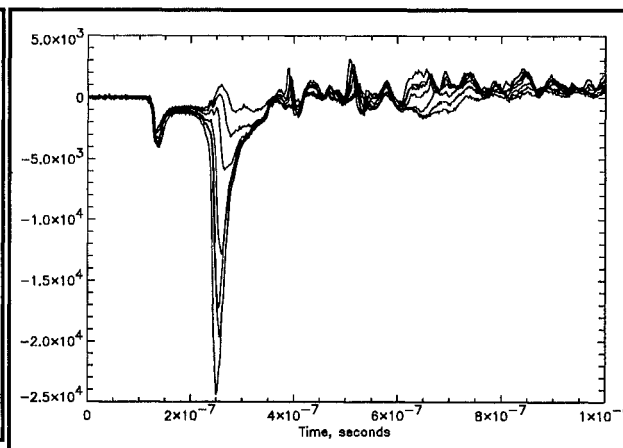

Figure 4(b). Experimental cell current waveforms.

Multiple Pulses

In some circumstances, it would be desirable to be able to operate a radiographic machine in rapid pulse mode, applying two pulses in rapid succession to a target. Having to reset the magnetic cores of an induction accelerator would be an additional complication, so the question arises whether one

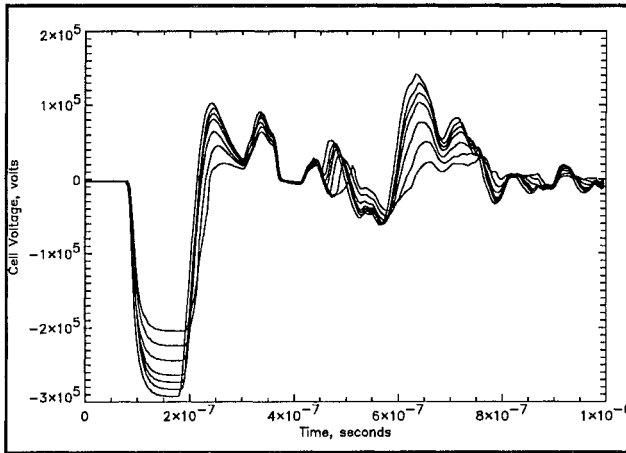

Figure 5(a) . Computed cell voltage waveforms.

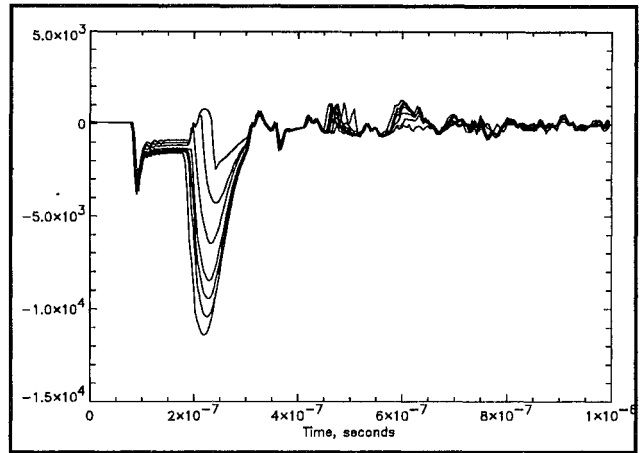

Figure 5(b) . Computed cell current waveforms.

could apply two rapid pulses without reset. One expects that the second pulse will not encounter the same conditions in the ferrite cores as the first pulse, but it is difficult to foresee what effect this will have on the quality of the voltage pulses. This is an example of an effect that would be difficult to implement experimentally (at least in full scale) that can be investigated using a suitable model. In particular, we first examine a single pulse that drives the cores just to saturation, and then examine two successive pulses, each of which is half the duration of the original pulse.

Figure 6 shows the time-integral of the voltage (volt-seconds) across six of the eleven sections of the multiple-section line. The flux (volt-seconds) of the first section (core) rises first to a partially saturated state, followed successively by each of the down stream cores. The first core does not fully saturate, however, as the impedance of the downstream cores prevents the current increase required for full saturation. When the flux in the final core increases, saturation of this last core occurs, the impedance of the line decreases, and a current wave propagates from the final to the first core. The final core is

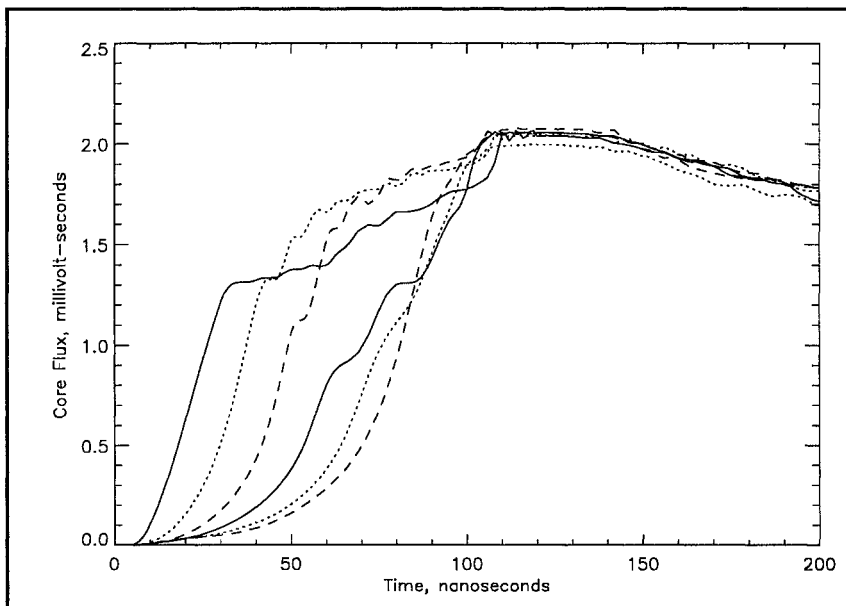

Figure 6. Volt-seconds across each core section, showing progressive saturation of ferrite cores in cell cavity.

the first to fully saturate, and the first core is the last to saturate.

Figure 7 shows the application of two voltage pulses, the first of which does not achieve saturation, but the second does. The dotted curve is the voltage of an ideal voltage source, and the solid curve is the voltage at the input to the cell. The amplitude of the second pulse is not as great as the first. This is because the input impedance to the line is less for the second pulse, due to the lingering saturation effects of the first pulse. It also appears that the flat-top of the second pulse displays some degree of droop, due also to cumulative saturation effects. Thus, to produce two voltage pulses of the same shape would require either a reset pulse or some supplementary shaping of the second pulse.

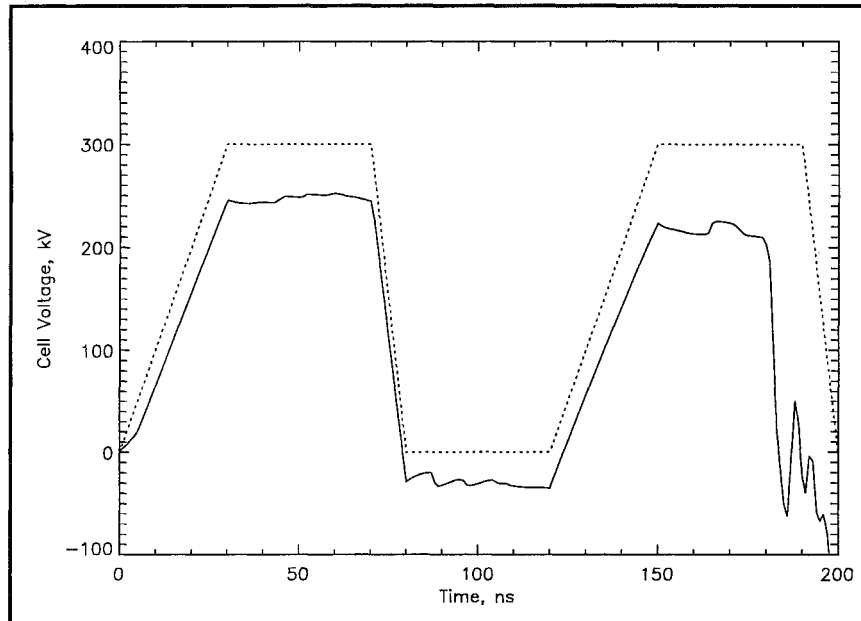

Figure 7. Voltage waveform on ferrite cores, during application of two voltage pulses, without intervening core reset pulse.

Conclusion

Modeling of linear induction accelerator cells indicates that it may be possible to generate multiple, high-quality voltage pulses, without a reset pulse, but with some supplemental shaping of the second pulse. This capability would facilitate the acquisition of multiple radiographs of a single event.

References

1. D.C.Jiles and D.L.Atherton, "Theory of Ferromagnetic Hysteresis," *Journal of Magnetism and Magnetic Materials* 61(1986) pp.48-60.
2. Micro-Cap IV, Spectrum Software, Sunnyvale, California.