

EJECTA PARTICLE SIZE DISTRIBUTIONS FOR SHOCK LOADED SN AND AL TARGETS

D.S. Sorenson

Los Alamos National Laboratory, Los Alamos, NM 87544

R.W. Minich

Livermore National Laboratory, Livermore, CA 94550

J.L. Romero

University of California, Davis, CA 95616

T.W. Tunnell

Bechtel Nevada, Los Alamos, NM 87544

Abstract

When a shock wave interacts at the surface of a metal sample "ejected matter" (ejecta) can be emitted from the surface. The mass, size, shape, and velocity of the ejecta varies depending on the initial shock conditions and the material properties of the target. To understand this phenomena, experiments have been conducted at the Pegasus Pulsed Power Facility (PPPF) located at Los Alamos National Laboratory (LANL). The facility is used to implode cylinders to velocities of many mm/ μ sec. The driving cylinder impacts a smaller target cylinder where shock waves of many hundreds of kilobars can be reached and ejecta formation proceeds. The ejecta particle sizes are measured using an in-line Fraunhofer holography technique. Over the years much work has gone into characterizing ejecta mass, but very little has been done to understand the particle size distributions. In this report, ejecta particle size distributions will be presented for shocked Al and Sn targets at pressures of 300 kb and 400 kb respectively. For the first time, particle distributions that results from microjet production will be presented. Results from these experiments will be presented along with predictions from percolation theory

I. INTRODUCTION

Metals under shock-loaded conditions can lead to complex phenomena depending on the properties of the material and initial shock conditions. The phenomena being reported here involves particle ejection which results from a shock wave interacting at a metal vacuum (gas) interface. For these experiments, particle sizes are measured using a holography technique. Ejecta experiments similar to these have been performed at other facilities [1,2,3,4,5] however, only a few measurements of particle sizes have been performed. For the first time, particle size distributions that result from microjet production will be presented. The energy in the microjets will depend on the initial groove angle that was machined into the target. Results from two experimental systems will be presented. These two experiments used Al and Sn targets. The shock pressures were 300 and 400 kb respectively. From the holography data, particle

distributions are extracted and are compared to predictions from percolation theory.

II. EJECTA PRODUCTION AND PERCOLATION THEORY

Shock strengths of many hundreds of kb can be obtained in aluminum and tin targets at the Pegasus Pulsed Power Facility (PPPF) located at the Los Alamos National Laboratory. Ejecta produced from these experiments range in velocities up to twice the target free surface velocity. The actual production of ejecta can be a complicated process. Fig.1 shows possible properties of the target material that may contribute to the formation of ejecta. For example, defects such as voids and inclusions give rise to density discontinuities. These density

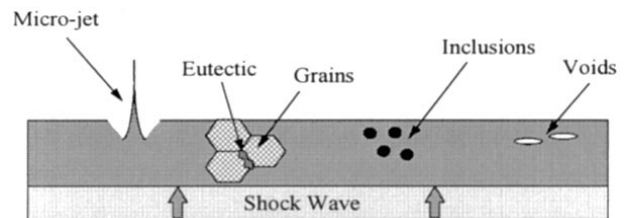

Figure 1. Illustration of possible ejecta formation processes.

discontinuities can then lead to break up of the metal as the shock wave passes through. In addition, grain boundaries can also be possible places for the metal to break up as a shock wave moves through the material. The figure also shows that if there are surface finish variations, microjets will form. These microjets can then break up into fragments forming another source of ejecta. Furthermore, initial shock conditions such as shock pressure and temporal profile can also contribute strongly in determining the properties of ejected material. For example, if the shock wave is strong enough, the material will melt which leads to enhanced ejecta production[1,6]. Developing a model that predicts the amount, size, and velocity of ejecta based on the above micromechanical processes is a difficult problem.

Report Documentation Page

Form Approved
OMB No. 0704-0188

Public reporting burden for the collection of information is estimated to average 1 hour per response, including the time for reviewing instructions, searching existing data sources, gathering and maintaining the data needed, and completing and reviewing the collection of information. Send comments regarding this burden estimate or any other aspect of this collection of information, including suggestions for reducing this burden, to Washington Headquarters Services, Directorate for Information Operations and Reports, 1215 Jefferson Davis Highway, Suite 1204, Arlington VA 22202-4302. Respondents should be aware that notwithstanding any other provision of law, no person shall be subject to a penalty for failing to comply with a collection of information if it does not display a currently valid OMB control number.

1. REPORT DATE JUN 1999	2. REPORT TYPE N/A	3. DATES COVERED -	
4. TITLE AND SUBTITLE Ejecta Particle Size Distributions For Shock Loaded Sn And Al Targets		5a. CONTRACT NUMBER	
		5b. GRANT NUMBER	
		5c. PROGRAM ELEMENT NUMBER	
6. AUTHOR(S)		5d. PROJECT NUMBER	
		5e. TASK NUMBER	
		5f. WORK UNIT NUMBER	
7. PERFORMING ORGANIZATION NAME(S) AND ADDRESS(ES) Los Alamos National Laboratory, Los Alamos, NM 87544		8. PERFORMING ORGANIZATION REPORT NUMBER	
9. SPONSORING/MONITORING AGENCY NAME(S) AND ADDRESS(ES)		10. SPONSOR/MONITOR'S ACRONYM(S)	
		11. SPONSOR/MONITOR'S REPORT NUMBER(S)	
12. DISTRIBUTION/AVAILABILITY STATEMENT Approved for public release, distribution unlimited			
13. SUPPLEMENTARY NOTES See also ADM002371. 2013 IEEE Pulsed Power Conference, Digest of Technical Papers 1976-2013, and Abstracts of the 2013 IEEE International Conference on Plasma Science. Held in San Francisco, CA on 16-21 June 2013. U.S. Government or Federal Purpose Rights License.			
14. ABSTRACT When a shock wave interacts at the surface of a metal sample ejected matter (ejecta) can be emitted from the surface. The mass, size, shape, and velocity of the ejecta varies depending on the initial shock conditions and the material properties of the target. To understand this phenomena, experiments have been conducted at the Pegasus Pulsed Power Facility (PPPF) located at Los Alamos National Laboratory (LANL). The facility is used to implode cylinders to velocities of many mm/usec. The driving cylinder impacts a smaller target cylinder where shock waves of many hundreds of kilobars can be reached and ejecta formation proceeds. The ejecta particle sizes are measured using an in-line Fraunhofer holography technique. Over the years much work has gone into characterizing ejecta mass, but very little has been done to understand the particle size distributions. In this report, ejecta particle size distributions will be presented for shocked Al and Sn targets at pressures of 300 kb and 400 kb respectively. For the first time, particle distributions that results from microjet production will be presented. Results from these experiments will be presented along with predictions from percolation theory			
15. SUBJECT TERMS			
16. SECURITY CLASSIFICATION OF:			17. LIMITATION OF ABSTRACT
a. REPORT unclassified	b. ABSTRACT unclassified	c. THIS PAGE unclassified	SAR
			18. NUMBER OF PAGES 4
			19a. NAME OF RESPONSIBLE PERSON

Many phenomena in nature involve fragmentation from very small (nuclei) to large (planets) scale systems [7,8,9,10]. A useful model that has been used to describe the fragment size distributions is percolation theory. For example, fragmentation of heavy nuclei resulting from high-energy nucleus-nucleus interactions [11,12] are described well using this theory. Percolation theory predicts simple power laws with specific values that depend of the dimensionality of the system being investigated. For example, if the system is one, two or three-dimensional, the powers are different [13]. This provides insight into the dimensionality of the phenomena being investigated. This theory is applied to the ejecta data and will be presented in this report.

III. EJECTA PARTICLE MEASUREMENTS

The experiments presented in this report were done at the Pegasus Pulsed Power Facility (PPPF) located at Los Alamos National Laboratory. Details of the facility are described in Ref [14]. Fig. 2 shows a view of the target assembly. In the figure an Al cylinder accepts current and is driven cylindrically inward. This cylinder is called the liner driver. The target, a 400-micron thick cylinder measuring 3.0 cm in diameter, is shown inside the liner. For a typical experiment the aluminum cylinder is driven to a velocity such that a shock wave many hundreds of kb is generated inside the target. Finally, a cylindrical tantalum collimator with various cutouts is used to control the number of particles entering the area where the ejecta measurements are made.

Various experimental techniques can be used to measure particles. Holography has the advantage that a three dimensional image of the ejecta is recorded. In particular, the in-line Fraunhofer holography technique was chosen because only one laser beam is required to make the measurement. This technique is described in

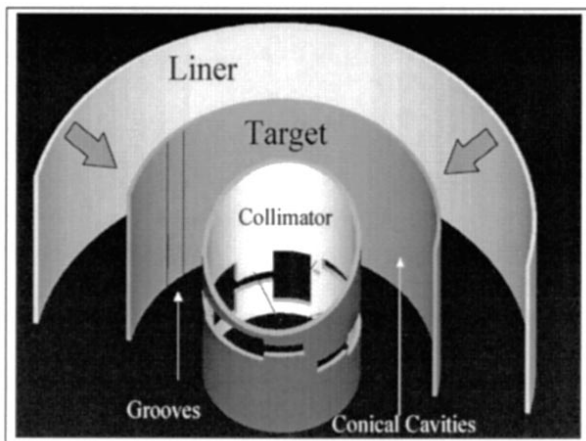

Figure 2. Target assembly. The outer cylindrical liner is what the Pegasus machine drives inward

more detail in Ref. [15,16,17]. Fig.3 shows in more detail the layout of the lens system in its configuration at the PPPF. The first lens element is located just a few

centimeters from the region where the ejecta particles are located. This is required if enough scattered light is to be collected for measuring particles with diameters as small as 1.5 microns. The high resolution lens (1000 lp/mm) relays the scattered and unscattered light waves over a cylindrical imaging volume 15 mm in diameter and 6mm

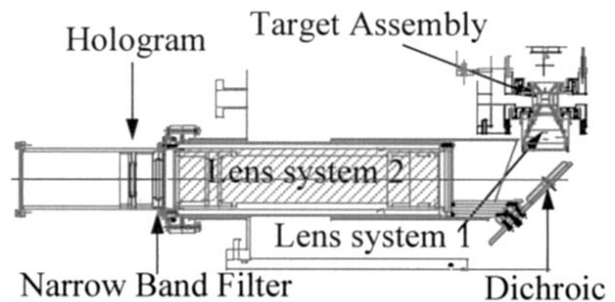

Figure 3. The in-line Fraunhofer holography experiment.

in depth. These light waves are relayed 93 cm to where the hologram is placed. After the experiment, the hologram is recovered and a three dimensional image of the ejecta is optically reconstructed. In order to quantitatively determine particle sizes, a hologram reconstruction system has been developed. The reconstruction system converts the optically reconstructed ejecta particles to digital image form. The digital images are then analyzed where particle shapes, sizes, and spatial coordinates are determined. This data is then used to

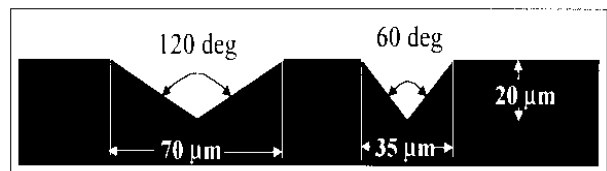

Figure 4. Cross section of the grooves that were used for the experiments

determine particle distributions. Details of this analysis system can be found in Ref [18].

IV. EJECTA PARTICLE SIZE DISTRIBUTION RESULTS

Results from two experiments will now be presented. The first experiment used an Al (6061 T6) target 400 μm thick. The target was prepared initially with a polished finish of 20 μm RMS. Next, grooves were machined into the target at various locations azimuthally around the target. Fig. 5 shows a cross section of these grooves. Grooves were either 20 or 100 microns deep. The groove angles were 60, 90 and 120 degrees

The Pegasus machine was setup to provide current necessary to drive the Al liner driver cylinder to a velocity of 3.4mm/ μsec just before the target is impacted. With this velocity, a shock pressure of 300 kb results in the Al

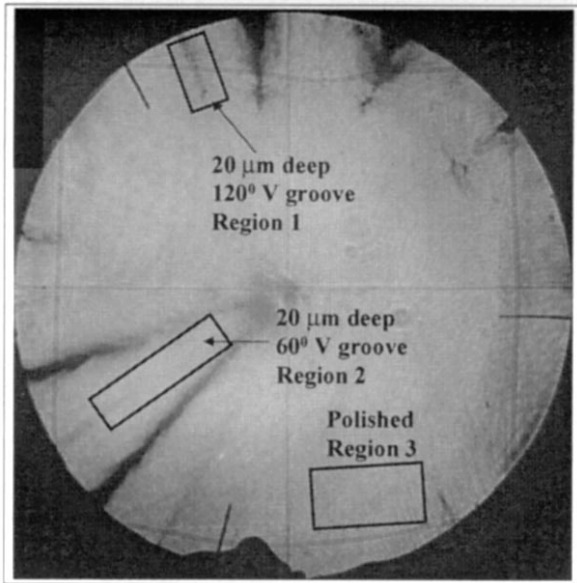

Figure 5. Image of hologram for the shocked Al.

target, and 400 kb when a Sn target is used. The holography experiment was performed just before the target impacted the collimator. See Ref [19] for more details about the dynamics of the target assembly. Radiography [20,21] in addition to other diagnostics were performed to measure the radius of the cylinder for different times. Fig. 5 shows an image of the hologram which was obtained for the Al target experiment. The figure is viewing through the collimator. The holographic film records a superposition of the interference patterns which are used to extract the particles, and a shadowgram of the ejecta. The outer part of the image is just inside of the collimator. It is observed that as the groove angle goes from the 60 to 120 degrees the microjet velocity decreases. This is well understood and is discussed in Ref [22]. This feature is exploited in these experiments to change the available energy in the microjet. Thus, for smaller angle grooves more energy is available for the fragmentation process.

V. COMPARISON WITH PERCOLATION THEORY

Data from two targets will be presented and compared to predictions from percolation theory. Fig 6 shows the particle distributions produced from a 120 degree, 20 μm deep V groove (solid circles), and a 60 degree, 20 μm deep V grooves (solid squares). Fig. 7 shows the particle distributions derived from region 1 (solid circles) and region 2 (solid squares) in figure 5. These correspond to microjets formed from a 120 degree 20 μm deep V groove and a 60 degree, 20 μm deep V groove respectively. The dots in Fig. 6 and Fig. 7 are the calculations for a single event using percolation theory. The lines are the best power fit to the calculations. We found that a three dimensional lattice near the critical probability worked

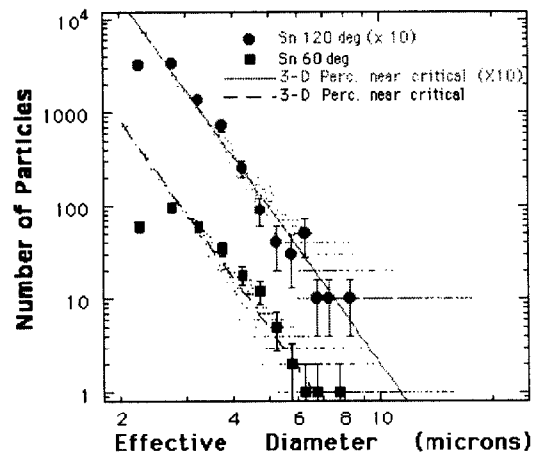

Figure 6. Ejecta particle size distribution for shocked Sn compared with predictions from 3-D percolation theory.

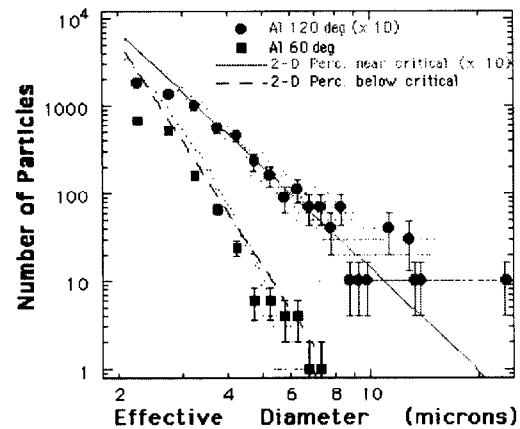

Figure 7. Ejecta particle size distributions for shocked Al compared with predictions from 2-D percolation theory.

well in fitting the Sn data, suggesting that the fragmentation is 3-D in nature. However, the Al data shown in Fig 7 can only be fit well using a 2-D lattice.

VI. CONCLUSIONS

In this report we have presented ejecta particle size distributions for shock loaded Sn and Al samples. The measurements were accomplished using a holography technique. Grooves were machined into the target sample producing well characterized microjets which break up into particles. The shapes of the distributions have been analyzed within the context of percolation theory. The measured distribution shape for shocked Sn at these pressures fit well with predictions from a 3-dimensional lattice. However, the Al data requires a 2-D lattice in order to obtain a fit to the data. This suggests that the nature of the break up for the Al cases are 2-D in nature.

The implications of these results are being further investigated.

VII. ACKNOWLEDGMENTS

The authors would like to acknowledge R.M. Malone, B. C. Froggett, R.L. Flurer, A.J. Taylor, and J. Roberts who ensured that the optical relay system and laser systems were properly setup for recording the hologram. The target assemblies were provided and built by W.E. Anderson, J. Bartos, and the rest of the fabrication team. In addition, many people were involved in setting up and recording data. These included D.T. Westley, C.Y. Tom, G. Allred, as well as the facility operations support team at the Pegasus Pulsed Power Facility headed by J. Cochrane, D.W. Scudder, and R. R. Bartsch. Other measurements were done to determine the dynamics of the target assembly. These were carried out by D.V. Morgan, D. Platts, J. Stokes, B. Broste, P. Rodriguez, and L. Veaser. We also acknowledge theoretical support from H. Lee, M. G. Sheppard, R.L. Bowers, R. Gore, G. Bazan, and A. J. Scannapieco. This work was supported by the High Energy Density Program and funded by the United States Department of Energy

VIII. REFERENCES

- [1] P. Andriot, P. Chapron, V. Lambert, F. Olive, "Influence of Melting on Shocked Free Surface Behavior using Doppler Laser Interferometry and X-Ray Densitometry," *Shock Waves in Condensed Matter*, Elsevier Science Publishers B.V., p. 277 (1983).
- [2] J.R. Assay, "Material Ejection from Shock-Loaded Free Surfaces of Aluminum and Lead," Sandia Laboratories Report SAND 76-0542 (1976) (unpublished).
- [3] P. Elias, P. Chapron, M. Mondot, "Experimental study of the slowing down of shock-induced matter ejection into argon gas." *Shock Compression in Condensed Matter 1989*, Elsevier Science Publishers B.B., p. 783, (1990).
- [4] C. McMillan, R. Whippley, *Proceedings of the 18th International Congress on High-Speed Photography and Photonics*, Xian, China (1988).
- [5] C.F. McMillan, "Size measurements of high velocity particle distributions," *SPIE 674 High Speed Photography (Pretoria)* 289 (1986).
- [6] P. Andriot, P. Chapron, F. Olive, "Ejection of material from shocked surfaces of tin, tantalum and lead alloys." *Shock Waves in Condensed Matter 81*, AIP Conf. Proc. N78, p. 505 (1981).
- [7] O. Sotolongo-Costa, Y. Moreno-Vega, J.J. Lloveras-González, and J.C. Antoranz, *Phys. Rev. Lett.* **76**, 42 (1996).
- [8] T. Kadono, *Phys. Rev. Lett.* **78**, 1444 (1997).
- [9] J.B. Elliot, Ph. D. Thesis, Purdue University, 1995 (unpublished).
- [10] J.B. Elliot, M.L. Gilkes, J.A. Hauger, A.S. Hirsch, E. Hjort, N.T. Porile, R.P. Scharenberg, B.K. Srivastava, M.L. Tincknell, and P.G. Warren, *Phy. Rev. C* **49**, 3185 (1994).
- [11] J.B. Elliot, Ph. D. Thesis, Purdue University, 1995 (unpublished).
- [12] J.B. Elliot, M.L. Gilkes, J.A. Hauger, A.S. Hirsch, E. Hjort, N.T. Porile, R.P. Scharenberg, B.K. Srivastava, M.L. Tincknell, and P.G. Warren, *Phy. Rev. C* **49**, 3185 (1994).
- [13] Dietrich Stauffer and Amnon Aharony, "Introduction to Percolation Theory," Taylor & Francis Inc, 1992.
- [14] M. P. Hockaday et. al., "Liner Target Interaction Experiments on Pegasus II" *Proceedings of the 10th IEEE Pulsed Power Conference*, Albuquerque, NM, 1995, p. 586.
- [15] D. S. Sorenson et al., "Particle Distribution Measurements Using In-Line Fraunhofer Holography," in *22nd International Congress on High-Speed Photography and Photonics*, Proc. SPIE **2869**, 206-213 (1997). D.L. Paisley, A.M. Frank (eds.)
- [16] D.S. Sorenson et al., "In-Line Particle Field Holography at Pegasus," *Proc. of the 10th IEEE Pulsed Power Conference*, Albuquerque, NM, 1995, p. 1024.
- [17] Chandra S. Vikram, "Particle Field Holography," *Cambridge Studies in Modern Optics* (1992).
- [18] T. W. Tunnell, et. al., "Deriving particle distributions from in-line Fraunhofer holographic data", *Proc. SPIE* **3163**, 558-565 (1997). See also Ref. 19.
- [19] R.L. Bowers et. al., "Precision Solid Liner Experiments on Pegasus II", *Proceedings of the 10th IEEE Pulsed Power Conference*, Albuquerque, NM, 1995, p. 607.
- [20] A.W. Obst et. al., "Performance of the Multi-Pulse X-ray imaging system for the Pulsed Power Hydrodynamic Experiments at LANL," *Proceedings of the 10th IEEE Pulsed Power Conference*, Albuquerque, NM, 1997, p. 448.
- [21] D. V. Morgan, D. Platts, J.S. Shlachter, D.L. Martinez, B. Carpernter, "Analysis of Radial Radiography for the liner stability series at Pegasus: PGII-59, PGII-62, and PGII-63," *Proceedings of the 10th IEEE Pulsed Power Conference*, Albuquerque, NM, 1997, p. 1381.
- [22] V. Frachet, P. Elias, J. Martineau, "Matter Ejection from shocked material: A Physical model to understand the effects of free surface defects." *Shock Waves in Condensed Matter 87*, , Elsevier Science Publishers B.V., p. 235 (1988).