

# A FOUR PULSE DRIVE SYSTEM FOR THE BEAM INDUCTION CELLS AND INJECTOR FOR DARHT AXIS 2\*

J. Downing, R. Carlson, and J. Melton, Los Alamos National Laboratory Los Alamos New Mexico 87544, and J. Fockler, TITAN PSI San Leandro California

## Abstract

The proposed drive system allows for the generation of up to four (4) high-quality radiographic pulses along one line-of-sight, having arbitrary pulse spacing ( $\approx 500$  ns). This concept uses a four-pulse drive system to drive both a 16-MeV ensemble of 250-kV, 4-kA induction cells and a four-pulse, 4-MeV injector. The key to this approach lies in the method used to combine four pulses from different generators in a manner that does not compromise the voltage flatness requirement of  $\pm 1\%$ . The induction cells use core material for only a single pulse and use a simple reverse bias circuit to reset the cores between pulses. A dual double-pulse format has been identified which provides a sequence of two pulses along one line-of-sight within a 2- $\mu$ sec window followed by a similar sequence of two pulses along the same line-of-sight within a second 2- $\mu$ sec window. The 2- $\mu$ sec windows can be separated by arbitrary time intervals of 2- to 10-  $\mu$ sec.

## I. INTRODUCTION

The architecture of this system preserves the fidelity of all four pulses by using adaptations/extensions of proven technologies previously used on PSI and/or LANL projects. The proposed 4-pulse system consists of 1) a common pulsed-power drive system for the injector and accelerator, 2) DARHT-like accelerator cells with ferrite cores, and 3) an injector with Metglas induction cores. The accelerator system is very similar to DARHT Axis 1 where the induction cells use core material for only a single pulse. A simple reverse bias circuit is used to reset the cores between pulses. The high voltage area of the accelerator cell has been redesigned to withstand the reverse reset voltage while retaining or improving the RF characteristics of the DARHT Axis 1 cell. [3].

The proposed 4-kA electron beam, multi-pulse injector consists of 16 individual 250-kV linear induction cells connected in series to achieve a diode voltage of 4-MeV. Metglas cores are used to minimize the size and cost of the injector. Two groups of cells connect to opposite sides of the diode head via two oil dielectric voltage adders. The cell and adder impedances have been carefully chosen to prevent any pulse distortion. The diode design is a conservative adaptation of the injectors presently operating in the Integrated Test Stand (ITS) at Los

Alamos and the CEA AIRIX facility in France.

## II. ACCELERATOR/INJECTOR 4-PULSE DRIVER SYSTEM

### A. Methodology For Producing 4-Pulses

This concept uses a four-pulse drive system that can drive both a 16-MeV ensemble of 250-kV, 4-kA induction cells and a four-pulse, 4-MeV injector. The key to this approach lies in the method used to combine four pulses from different generators in a manner that does not compromise the voltage flatness requirement of  $\pm 1\%$ . This stringent voltage flatness criterion is crucial to small X-ray spot size production. Figure 1 shows pictorially the evolution of an induction cell driver from a single pulse to a four-pulse system. The first step represents the type of system currently employed on DARHT Axis 1. Replacement of the ballast resistor with a second pulse generator allows combination of two pulses, while providing a similar amount of cell loading and voltage regulation. The delay lines prevent distortion of the second pulse by reflections from impedance mismatches. Finally, replacing each individual PFL with two PFLs connected in series creates the four-pulse train. Laser triggered gas switches, LTGS, are used to discharge the double-PFLs in sequence. Once discharged, the PFLs act as matched output lines for the second PFL that is in series with the first PFL. This same approach is used on the PHERMEX Double-Pulser at Los Alamos. Laser triggered dump switches are located at the end of the double PFL modules. These switches are used in concert with the delay lines to eliminate reflections from the load and other modules. The switches are triggered just before the transmitted pulses arrive at the modules, diverting the energy into matched loads. Modeling indicates that this four-pulse generator design is capable of generating the necessary waveshape fidelity.

Figure 2 shows a schematic diagram of the proposed four-pulse system driving a 1-MeV, 4-cell segment of the electron beam LIA. A 20-MeV accelerator with a 4-MeV injector requires sixteen such 4-cell units. The proposed prime power unit, PPU, design is the same as the 1.5-MeV unit presently used on the DARHT Axis 1 injector except that the transformer turns ratio is only half as large. The laser triggered gas switch, LTGS, used to

\*Work supported under the auspices of the United States Department of Energy.

## Report Documentation Page

*Form Approved*  
*OMB No. 0704-0188*

Public reporting burden for the collection of information is estimated to average 1 hour per response, including the time for reviewing instructions, searching existing data sources, gathering and maintaining the data needed, and completing and reviewing the collection of information. Send comments regarding this burden estimate or any other aspect of this collection of information, including suggestions for reducing this burden, to Washington Headquarters Services, Directorate for Information Operations and Reports, 1215 Jefferson Davis Highway, Suite 1204, Arlington VA 22202-4302. Respondents should be aware that notwithstanding any other provision of law, no person shall be subject to a penalty for failing to comply with a collection of information if it does not display a currently valid OMB control number.

|  |                                    |  |  |                                 |                                 |
|--|------------------------------------|--|--|---------------------------------|---------------------------------|
| 1. REPORT DATE<br><b>JUN 1999</b>  | 2. REPORT TYPE<br><b>N/A</b>       | 3. DATES COVERED<br><b>-</b>             |  |                                 |                                 |
| 4. TITLE AND SUBTITLE<br><b>A Four Pulse Drive System For The Beam Induction Cells And Injector For Darht Axis 2</b>   |                                    | 5a. CONTRACT NUMBER                      |  |                                 |                                 |
|  |                                    | 5b. GRANT NUMBER                         |  |                                 |                                 |
|  |                                    | 5c. PROGRAM ELEMENT NUMBER               |  |                                 |                                 |
| 6. AUTHOR(S)   |                                    | 5d. PROJECT NUMBER                       |  |                                 |                                 |
|  |                                    | 5e. TASK NUMBER                          |  |                                 |                                 |
|  |                                    | 5f. WORK UNIT NUMBER                     |  |                                 |                                 |
| 7. PERFORMING ORGANIZATION NAME(S) AND ADDRESS(ES)<br><b>Los Alamos National Laboratory, Los Alamos, New Mexico 87543</b>  |                                    | 8. PERFORMING ORGANIZATION REPORT NUMBER |  |                                 |                                 |
| 9. SPONSORING/MONITORING AGENCY NAME(S) AND ADDRESS(ES)  |                                    | 10. SPONSOR/MONITOR'S ACRONYM(S)         |  |                                 |                                 |
|  |                                    | 11. SPONSOR/MONITOR'S REPORT NUMBER(S)   |  |                                 |                                 |
| 12. DISTRIBUTION/AVAILABILITY STATEMENT<br><b>Approved for public release, distribution unlimited</b>  |                                    |  |  |                                 |                                 |
| 13. SUPPLEMENTARY NOTES<br><b>See also ADM002371. 2013 IEEE Pulsed Power Conference, Digest of Technical Papers 1976-2013, and Abstracts of the 2013 IEEE International Conference on Plasma Science. Held in San Francisco, CA on 16-21 June 2013. U.S. Government or Federal Purpose Rights License.</b>   |                                    |  |  |                                 |                                 |
| 14. ABSTRACT<br><b>The proposed drive system allows for the generation of up to four (4) high-quality radiographic pulses along one line-of-sight, having arbitrary pulse spacing (= 500 ns). This concept uses a four-pulse drive system to drive both a 16-MeV ensemble of 250-kV, 4-kA induction cells and a four-pulse, 4-MeV injector. The key to this approach lies in the method used to combine four pulses from different generators in a manner that does not compromise the voltage flatness requirement of f 1%. The induction cells use core material for only a single pulse and use a simple reverse bias circuit to reset the cores between pulses. A dual double-pulse format has been identified which provides a sequence of two pulses along one line-of-sight within a 2-usec window followed by a similar sequence of two pulses along the same lineof-sight within a second 2-psec window. The 2-psec windows can be separated by arbitrary time intervals of 2- to lo- usec.</b> |                                    |  |  |                                 |                                 |
| 15. SUBJECT TERMS  |                                    |  |  |                                 |                                 |
| 16. SECURITY CLASSIFICATION OF:  |                                    |  | 17. LIMITATION OF ABSTRACT<br><b>SAR</b> | 18. NUMBER OF PAGES<br><b>4</b> | 19a. NAME OF RESPONSIBLE PERSON |
| a. REPORT<br><b>unclassified</b>   | b. ABSTRACT<br><b>unclassified</b> | c. THIS PAGE<br><b>unclassified</b>      |  |                                 |                                 |

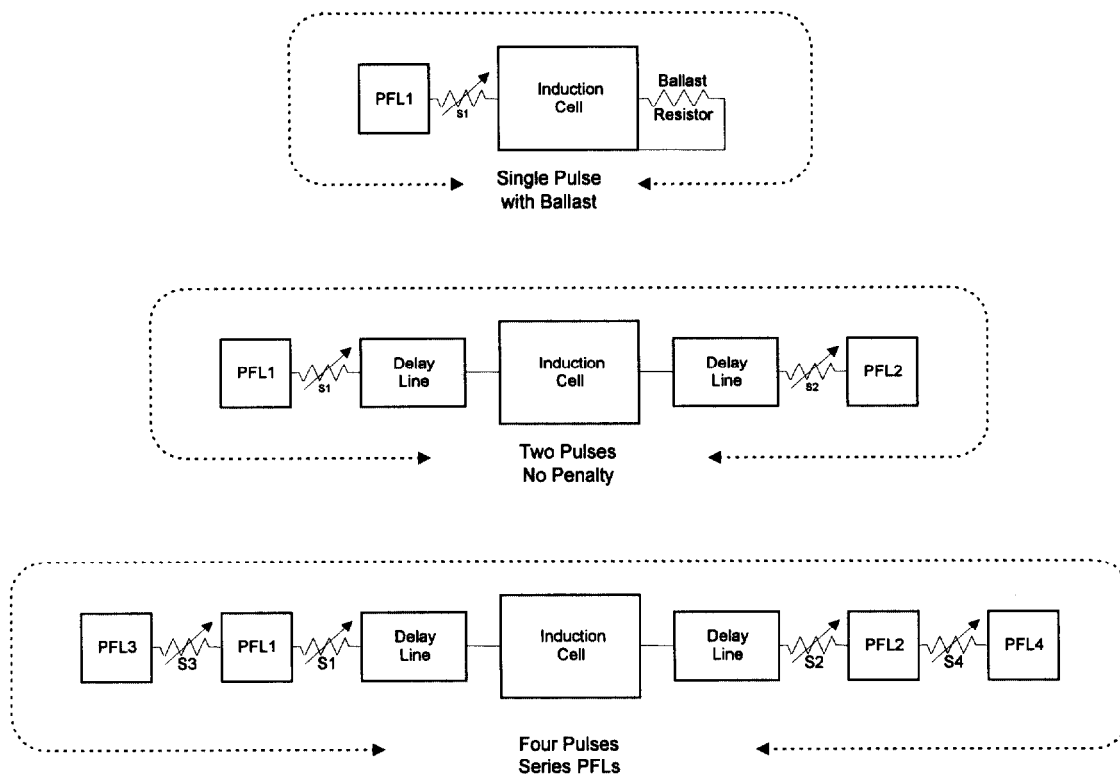

Figure 1. Evolution of the final configuration of the four pulse driver

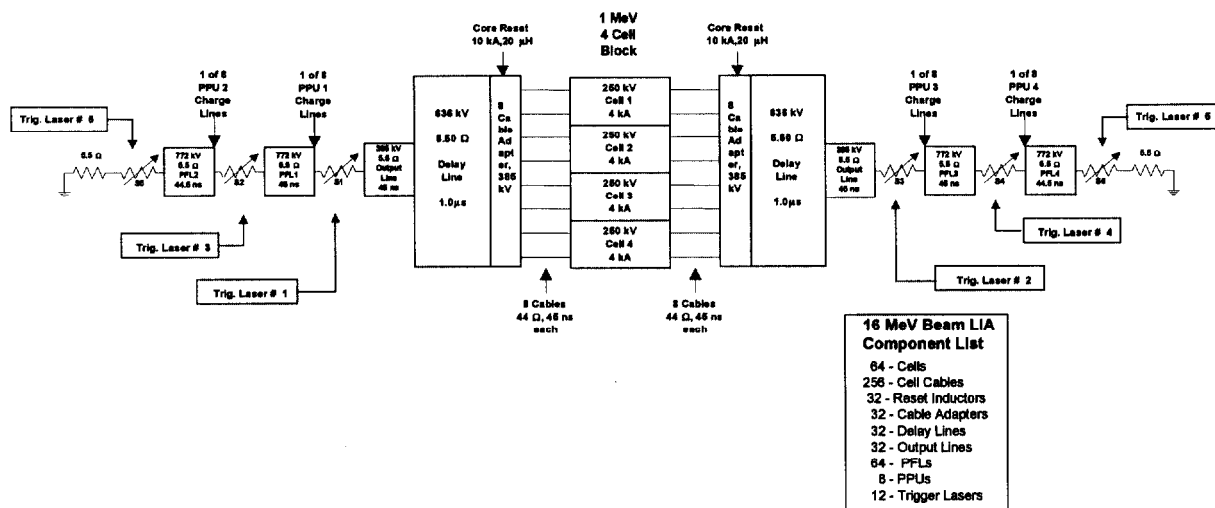

Figure 2. Block Diagram of a 4-cell unit of 16-MeV, 4-kA LIA. Total number of cells required is 64.

switch out each PFL is also approximately a factor of two smaller than the ITS Injector Blumlein switches. As a result, the same Spectra Physics YAG laser now used to trigger the four DARHT Axis 1 Injector switches will trigger 8 PFL switches.

Impedance tailoring of either the PFLs and/or the output lines can be used to fine tune pulse flatness as was

done on the DARHT and AIRIX injectors. We can easily correct for the anticipated voltage ramp up of 1% due to the 0.8-μsec delay line by these techniques.

The proposed 4-kA electron beam, multi-pulse injector design consists of 16 individual 250-kV induction cells connected in series to achieve a diode voltage of 4-MeV. The diode region is very similar to the diodes presently in

use on the DARHT Axis 1 and the AIRIX injectors. This represents a conservative design since only one half of the diode voltage is being fed from each side.

### B. Common Elements of 4-Pulse Driver System

The four-pulse driver system is used to drive both a 16-MeV ensemble of 250-kV, 4-kA induction cells and a four-pulse, 4-MeV injector. A schematic diagram of a segment of the proposed 4-pulse system capable of driving a 1-MeV, 4-kA, 4-cell unit is shown in Figure 2. A 20-MeV accelerator with a 4-MeV injector requires sixteen 4-cell units. Similarly, the same 4-pulse system is capable of driving a 1-MeV, 4-kA, 2-cell unit. The common elements in these two drive systems are 1.) the Prime Power Unit (PPU), 2.) the double PFL module, 3.) the laser triggering systems, 4.) the delay lines, and 5.) the core reset systems.

### C. Double PFL Module (Figure 4)

The first 5.5-ohm PFL is 60 inches, 45 ns long, and the second 5.5-ohm PFL is 44.5 ns long. The ID of the outer conductor is 15.0 inches and the OD of the inner is 6.625 inches. The outer conductor is the most severely stressed at 50 kV/cm for 772 kV charge voltage. This field is conservative breakdown fraction (BDF) of 59%. Corresponding parameters for the injector PFLs are 47 kV/cm at 730 kV charge voltage, and a conservative BDF of 53%.

The output line has the same diameter as the PFLs in order to simplify their interface. As a result of its shorter stress time ( $t_{eff} = 0.09 \mu s$ ), the output line runs at a very low BDF of 12% to 13%.

Figure 3 shows a schematic of the double PFL module and a TLCODE simulation of an unoptimized 4-pulse

format. No attempt was made to optimize the pulse shapes. All the relevant features of the module are shown on the schematic. An RC snubber is used near the front-end of each PFL to aid in transient control, and the laser triggered dump switches are located at the end of each module.

TLCODE circuit models have been constructed for the 2-pulse, series PFL modules to address the pulse distortion issues for the second and subsequent pulses. These models have been used to evaluate techniques and to create "hardware knobs" that can be used to tune the system and produce the required pulse format and fidelity. "Hardware knobs" identified to fine tune the systems are 1) RC snubber in the PFLs, 2) variable charge voltages in individual sets of PFLs, 3) variable electrical lengths for individual PFLs, 4) system optimized delay line length, 5) triggered dump switches for each double PFL module, and 6) impedance tailoring of either the PFLs or the output lines. Modeling results indicate that the proposed four-pulse generator approach can indeed obtain the necessary waveshape fidelity.

### D. Prime Power Unit (PPU)

The PPU design is the same as the 1.5 MV unit presently in use on the DARHT Axis 1 injector except that we reduced the transformer turns ratio from 15 to 7. The new autotransformer from Stangeness has a leakage inductance of 40  $\mu H$  and dimensions of 28.5 inches x 26 inches x 36 inches in height. This reduction in transformer size will allow a significant reduction in PPU tank size. A single PPU will pulse charge eight each 9.6-nF PFLs to either 730 kV or 772 kV in 4.8  $\mu sec$  ( $T/2 = 5.4 \mu sec$ ).

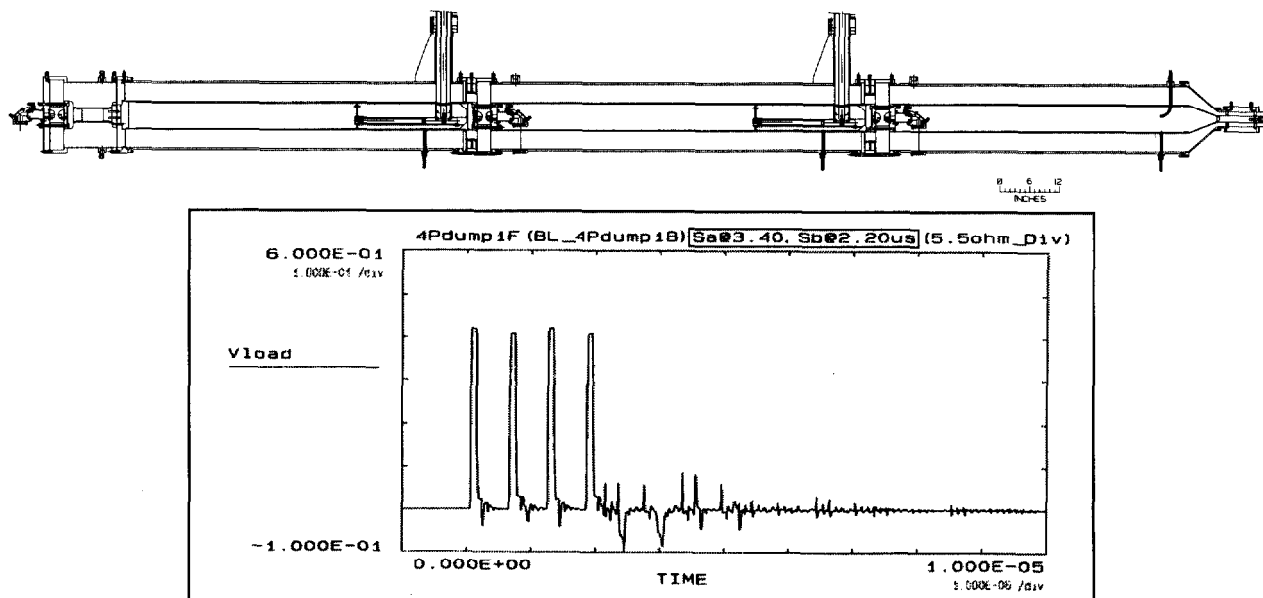

Figure 3. Double PFL Module with late time transient protection.

### *E. Laser Triggering Systems*

The LTGS design is a factor of 2.3 (1500 kV/650 kV) smaller than the DARHT Axis 1 Injector Blumlein switches. As a result, the same Spectra Physics 266 nm quadrupled YAG laser presently used to trigger the four ITS Injector switches can trigger 8 PFL switches in the proposed design. On the DARHT Axis 1 Injector, laser beam access to the switches was readily available via the outer conductor of the Blumlein. In this design the beam travels radially through water to a mirror on the PFL axis. The NIKE laser pulser switches at NRL presently use this same arrangement..

### *F. Delay Lines*

Peak voltage stress in the accelerator delay lines of 635 kV for 90 ns occurs when a 385 kV forward going pulse overlaps with a 250 kV pulse returning from an induction cell. For these calculations the outer conductor (I.D.) is 4.00 inches and the inner conductor (O.D.) is 1.75 inches. These dimensions correspond to a commercially available cable that can use water as the dielectric media. The BDF is 59%. For added safety the next size larger cable could be used.

The skin effect resistive losses in the 1- $\mu$ sec (110-ft long) delay line will create a ramp on the pulse flattop. A minor voltage ramp of  $\sim$ 1% is anticipated and will be compensated for by tapering the PFLs.

### *G. Drive Cable/Cable Interface*

The drive cable/cable interface is patterned after the system used on SLIA at PSI. This cable interface also includes the  $\approx$ 20- $\mu$ H inductor used for the reset system. The reset inductor is located inside the inner conductor of the interface section.

The 44 ohm, 60 foot long cell drive cables for this application will be type 2158 manufactured by Times Microwave Systems and Dielectric Sciences. Forty such cables, as well as their 8-cable to water line adapter, are presently in use on the SLIA induction cells. On SLIA this system has operated at 300 kV for 2000 shots without failure. The system has survived over 350 kV for fewer shots.

### *H. Core Reset Systems*

Core reset between pulses is provided by establishing a reverse-bias current through the LIA cores in each cell using a large ( $\approx$ 20- $\mu$ H) inductor attached to each cell. The time constant for current changes in this circuit is long,  $\approx$  100  $\mu$ sec. This current provides the back-EMF for reset, and the level of reset current controls the amplitude of the back-EMF, and, therefore, the time required to reset the cores.

## **III. CONCEPT SUMMARY**

The short-pulse LIA system discussed in this paper uses technologies for the drive system which are adaptations/extensions of proven operating systems. All

the elements of the 4-pulse-pulsed-power system have been modeled, most of the models have been benchmarked, and the models have been integrated into an overall system model. These models have been used to evaluate techniques and to create "hardware knobs" that can be used to tune the system and produce the required pulse format and fidelity.

## **IV. ENHANCED CAPABILITIES**

A dual double-pulse format has been identified which provides a sequence of two pulses along one line-of-sight within the first 2- $\mu$ sec window followed by a similar sequence of two pulses along the same line-of-sight within a second 2- $\mu$ sec window. The 2- $\mu$ sec windows can be separated by arbitrary time intervals of 2- to 10-  $\mu$ sec. This unique capability offers an enhanced experimental range over competing technologies.

## **V. REFERENCES**

- [1] J. Fockler, H. Nishimoto, "A FOUR-PULSE DRIVE SYSTEM FOR THE BEAM INDUCTION CELLS AND INJECTOR OF DARHT," Final Report, PSI-FR-1762/3761-01, July, 1996.
- [2] J. Fockler, M. Christensen, "Detailed Design Analysis of A Two-Pulse Series PFL Module," Final Report, PSI-FR-1788-01, November, 1996.
- [3] C.C. Shang, et al, "BBU DESIGN OF LINEAR INDUCTION ACCELERATOR CELLS FOR RADIOGRAPHY APPLICATION," 1997 Particle Accelerator Conference, May, 1997.
- [4] T. P. Hughes, D. C. Moir, and P. W. Allison, Proc. 1995 Particle Accelerator Conference, p. 1207.
- [5] J. Fockler et al., Proc. 8th International Pulsed Power Conference, San Diego, 1996, p. 177.
- [6] J. E. Boers, Proc. 1995 Particle Accelerator Conference, p. 2312.
- [7] M. Burns, P. Allison, R. Carlson, J. Downing, D. Moir, and R. Shurter, Proc. XVIII International LINAC Conference, Geneva, 1996. (LA-UR-96-2946).
- [8] T. P. Hughes, R. M. Clark, R. L. Carlson, and D. C. Moir, MRC/ABQ-R-1391, 1991.