

*The Development and Testing of Subnanosecond-Rise, Kiloherzt Oil Switches**

*P. D'A. Champney, R. Curry, C. Eichenberger, J. Fockler,
D. Morton, R. Sears, I. Smith*

*Pulse Sciences, Inc.
600 McCormick Street
San Leandro, CA 94577*

*R. Conrad
U.S. Army Missile Command
Redstone Arsenal
AL, USA*

ABSTRACT

Subnanosecond risetime, kilohertz oil switches have been developed and tested at Pulse Sciences, Inc. The development was divided into two phases. During the first phase, a two-three pulse breakdown test at 130 kV was used to measure the recovery characteristics of a large area oil switch at up to 200 pps. Different geometries were explored along with oil flow rates required. The oil flow experiments and the effect of electrode/flow geometry are reported.

Successful test results in the first phase led to the Phase II design of a high repetition rate modulator based on flowed oil switches that develop pulses tens of nsec in duration. The modulator incorporates three oil switches: (1) a transfer switch, (2) a sharpening switch, and (3) a peaking/sharpening switch. Initial operation and parameterization has shown operation and recovery of the oil switches at up to 290 kV, and rep-rates of 200 pps respectively. Lower voltage tests at 140 kV and 170 kV have shown recovery at up to 1250 and 1000 pps. Peak energies of 50 Joules per pulse have been transferred into a 97 ohm resistive load, with a 280 ps risetime.

The modulator design and performance are reported. The influence of electrode/flow geometry upon the recovery of oil switches is described, along with the breakdown and other characteristics of the switches.

INTRODUCTION

Investigations have been conducted to characterize fast-closing repetitively-pulsed high voltage switches using a flowing oil dielectric medium. These investigations were conducted to develop a low inductance switch with subnanosecond risetimes, superior in performance and risetime to high pressure gas switches. The goal also included development of a switch which would be smaller in size to a flowed gas switch yet easier and more reliable to operate.

The dielectric selected for these investigations was flowed transformer oil. The oil switch has many desirable qualities qualifying it for consideration as a repetitive switch medium. Liquid dielectrics when pulse charged have breakdown fields substantially higher than gaseous dielectrics^[1]. Liquid dielectrics also have an area and time dependent breakdown field. Thus, small area electrodes in oil or liquid dielectric can be pulse charged to much higher stresses than those normally observed in gaseous dielectrics. Moreover, a time dependency is observed which is stronger in liquids than it is in gas. This results in much higher operating fields and much shorter switch risetimes if liquid dielectrics are employed.

To establish the applicability of flowed liquid dielectrics to high voltage, repetitive modulator applications, a two-phase experimental program was undertaken. During phase one of the experimental program, a two-three pulse high voltage oil breakdown test was used to test recovery. A spark-gap modulator test stand was built to over-voltage a large area flowed oil switch gap. Various flow and electrode geometries applicable to both transfer and peaking switch geometries were tested. Porous electrodes whereby flowed oil was injected through the electrode was also investigated. The experiment and a discussion of the test results are reviewed under the Oil Switch Recovery Experimental Background Section and the Oil Switch Recovery Test Result Section.

Phase two of the experimental program was used to both apply the phase one experimental flow measurements and scale them to continuous repetitive operation at 1250 pps. Subsequently the applicability of liquid dielectric switches to both transfer and peaking switch applications was evaluated. The results of these experiments are reported in the Subnanosecond Rise, High Repetition Rate Test Stand Section and the Subnanosecond Rise, High Repetition Rate Experiments Test Section. Emphasis of this investigation included the generation of 280 ps risetime pulses at hundreds of kilovolts, while generating tens of nanosecond pulsewidths.

OIL SWITCH RECOVERY EXPERIMENTAL BACKGROUND

Three axial flow geometries were tested during the oil switch recovery experiments. The three flow geometries included (a) axially opposing radially outward flow, (b) axially outward radially inward flow, and (c) axially through radially inward flow. The three flow patterns are shown in Figure 1 for clarification.

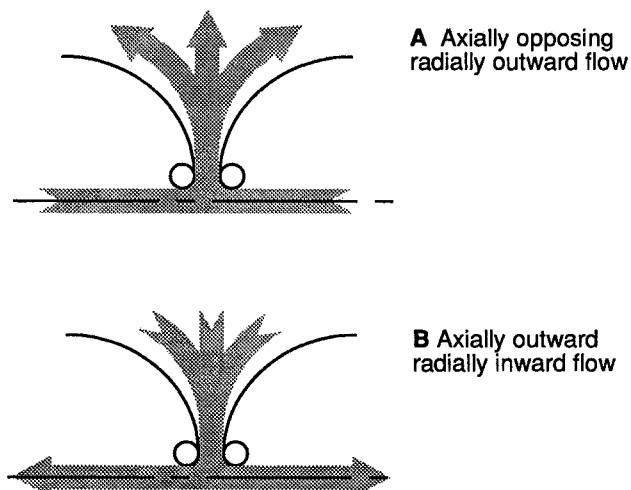

**This research was sponsored by U.S. Army Missile Command under Prime Contract No. DAAH01-87-C-1111.*

Report Documentation Page

Form Approved
OMB No. 0704-0188

Public reporting burden for the collection of information is estimated to average 1 hour per response, including the time for reviewing instructions, searching existing data sources, gathering and maintaining the data needed, and completing and reviewing the collection of information. Send comments regarding this burden estimate or any other aspect of this collection of information, including suggestions for reducing this burden, to Washington Headquarters Services, Directorate for Information Operations and Reports, 1215 Jefferson Davis Highway, Suite 1204, Arlington VA 22202-4302. Respondents should be aware that notwithstanding any other provision of law, no person shall be subject to a penalty for failing to comply with a collection of information if it does not display a currently valid OMB control number.

1. REPORT DATE JUN 1991	2. REPORT TYPE N/A	3. DATES COVERED -	
4. TITLE AND SUBTITLE The Development and Testing of Subnanosecond-Rise, Kilohertz Oil Switches		5a. CONTRACT NUMBER	
		5b. GRANT NUMBER	
		5c. PROGRAM ELEMENT NUMBER	
6. AUTHOR(S)		5d. PROJECT NUMBER	
		5e. TASK NUMBER	
		5f. WORK UNIT NUMBER	
7. PERFORMING ORGANIZATION NAME(S) AND ADDRESS(ES) Pulse Sciences, Inc. 600 McCormick Street San Leandro, CA 94577		8. PERFORMING ORGANIZATION REPORT NUMBER	
9. SPONSORING/MONITORING AGENCY NAME(S) AND ADDRESS(ES)		10. SPONSOR/MONITOR'S ACRONYM(S)	
		11. SPONSOR/MONITOR'S REPORT NUMBER(S)	
12. DISTRIBUTION/AVAILABILITY STATEMENT Approved for public release, distribution unlimited			
13. SUPPLEMENTARY NOTES See also ADM002371. 2013 IEEE Pulsed Power Conference, Digest of Technical Papers 1976-2013, and Abstracts of the 2013 IEEE International Conference on Plasma Science. Held in San Francisco, CA on 16-21 June 2013. U.S. Government or Federal Purpose Rights License			
14. ABSTRACT Subnanosecond risetime, kilohertz oil switches have been developed and tested at Pulse Sciences, Inc. The development was divided into two phases. During the first phase, a two-three pulse breakdown test at 130 kV was used to measure the recovery characteristics of a large area oil switch at up to 200 pps. Different geometries were explored along with oil flow rates required. The oil flow experiments and the effect of electrode/flow geometry are reported.			
15. SUBJECT TERMS			
16. SECURITY CLASSIFICATION OF:			17. LIMITATION OF ABSTRACT
a. REPORT unclassified	b. ABSTRACT unclassified	c. THIS PAGE unclassified	SAR
			18. NUMBER OF PAGES 7
			19a. NAME OF RESPONSIBLE PERSON

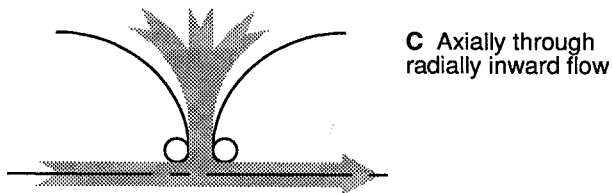

Figure 1. Oil flow geometries used to investigate recovery characteristics of oil switches.

Large area porous electrodes as shown in Figure 2 were used for the investigation. The base of the main switch electrode was made of stainless steel and 1.6 mm porous stainless steel was selected as the switch gap material. The porous material was formed by a stamping process and welded into place. The 0.64 cm axial hole was a compromise between restricting the flow and the resultant electric field enhancement present due to enlargement of the hole. To minimize the field enhancement, the electrode material was carefully blended during manufacture. Figure 3 shows a photograph of the electrodes after the experiments. Erosion was insignificant after 1000 shots, with primary switch closure centered about the axial hole.

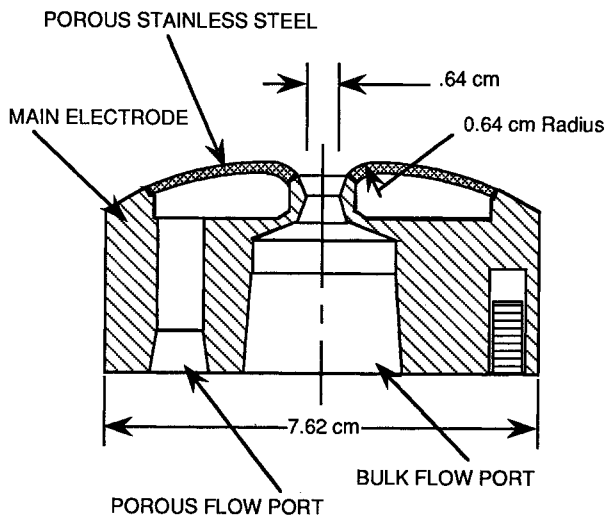

Figure 2. Porous stainless steel electrode geometry used to test the recovery of oil switches.

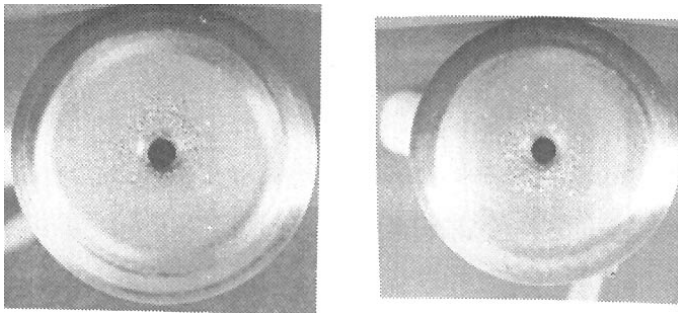

Figure 3. Stainless electrodes after 1000 shots.

The oil flow system was designed to enable simple flow configuration changes while allowing independent controlled bulk and porous electrode flow rates. Two oil pumps were used, a high pressure low flow-rate pump for the porous flow and a low pressure high flow-rate pump for the bulk oil flow. The insulating oil in which the electrodes were immersed was maintained at ambient pressure during the course of the experiments. The porous flow pump was cap-

able of developing a pressure of 7.5 atm. which enabled a flow of up to 0.05 ℓ /sec through the pores. This flow corresponded to a normal surface velocity of 60 cm/sec. With turbulence effects it was conjectured that this might correspond to an oil velocity away from the electrodes of about 10 cm/sec. This would imply possible debris movement of about 1mm at 100 pps. The bulk flow oil loop was configured for a peak flow rate of 1.3-1.6 ℓ /sec prior to onset of cavitation. For switch spacings of interest this flow rate provided oil velocities of 10 meters/sec at the peak electric radial field location on the electrodes.

To pulse charge the oil switch a simple spark gap modulator was built. The modulator was designed to provide up to a three-pulse burst at a representative rep-rate of 200 pps. The modulator with the accompanying component values are shown in Figure 4. The pulse sequence begins when spark gap S1 is triggered, pulse charging capacitor C1 to 90 kV in 112 μ s. Following the pulse charge of C1, S1 is allowed to recover for about 5 ms (200 pps). Spark gap S2 is then triggered, pulse charging both S3 the oil switch under test, and C2 a fast coaxial water capacitor. Both the capacitor C2 and the oil switch are pulse charged to 130 kV in 220 nsec. The oil switch self-breaks transferring the energy stored in C1 and C2 into a resistive load of 22.6 ohms. The e-fold decay is on the order of 360 nsec. Under normal operation 5.9 kA, 1.44 mCb and 65 J with an action of 2.9 J/ohm is transferred through the oil switch. Under fault mode conditions whereby switches S1 and S2 fail to recover in the inter-pulse burst, 69 mCb, 1680 J and 74.3 J/ohm as a result of filter capacitor C0 discharging into the 22.6 ohm load resistor is transferred through the oil switch.

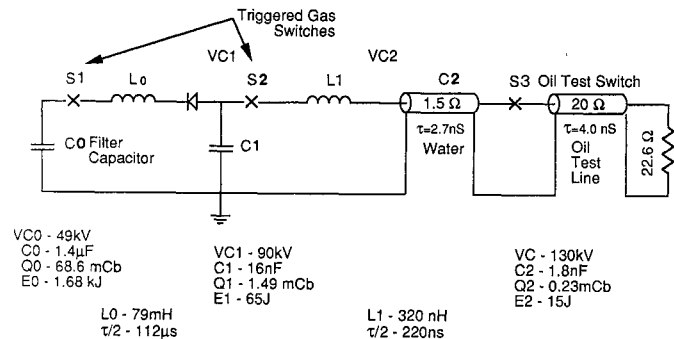

Figure 4. Spark gap modulator test stand.

OIL SWITCH RECOVERY TEST RESULTS

The oil switch was set to self-break at 130 kV at a gap spacing 1.4 mm. The 1-cos pulse charge had a t_{eff} (63% of breakdown) of 92 nsec. The 1-cos pulse charge was monitored with a copper sulfate resistive monitor placed across C1. The copper sulfate monitor was also used to monitor the switchoff time of S3 the oil switch. A fast capacitive monitor with a risetime of less than 400 ps was mounted in the 20 ohm output oil line. This capacitive monitor was not calibrated in-situ for voltage amplitude but did provide an indication of the oil switch risetime and recovery characteristics.

Under optimum recovery conditions the measured output pulse risetime was found to be 3.4 nsec (10-90%). This risetime was in good agreement with the calculated 3.3 nsec resistive risetime based on an applied field of 0.93 MV/cm and an impedance of 2.15 ohms. The resistive phase calculations were based on Charlie Martin's formulae

$$\tau_{resistive} = \frac{8.3 \text{ ns } (\rho)^{1/2}}{Z^{1/3} E^{4/3}} \quad (1)$$

where Z is in ohms, E is in MV/cm, and ρ is the density ratio of the liquid with respect to water.

Initial oil breakdown tests without porous flow established the best bulk flow configuration. Configuration B, the axially-outward, radially-inward flow had the best recovery characteristics for the three flow geometries shown (Figure 1). Flow Configuration B was followed in order by C and A. At 50 pulses/sec, Configuration A required a flow of 0.32 ℓ /sec while Configuration B required only 0.21 ℓ /sec. At 100 pps, Configuration B required 0.38-0.47 ℓ /sec for interpulse recovery while Configuration A failed to recover even at 1.27 ℓ /sec. Above 1.3 ℓ /sec, cavitation of the oil occurred. Upon cavitation, little or no recovery was found.

Configuration B was tested for recovery with and without porous flow. At 200 pps, porous flow rates of 0.05 ℓ /sec had little or no effect on recovery. At 200 pps the flow-rate required for the switch recovery was found to be between 0.63 ℓ /sec and 0.95 ℓ /sec. A detailed report of the tests is presented in Reference 1.

Finally a scan of volumetric bulk flow rate versus various rep-rate was performed. For the tests, the optimal B configuration without porous flow was used to produce the test results in Figure 5. The slope is linear within the accuracy of the data as expected.

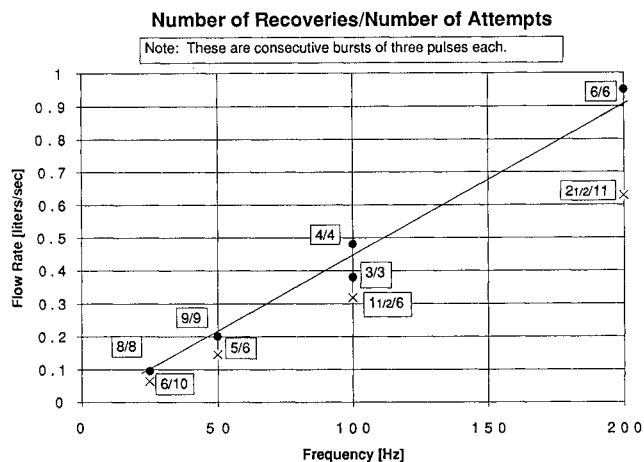
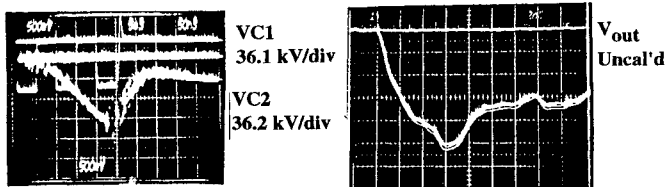
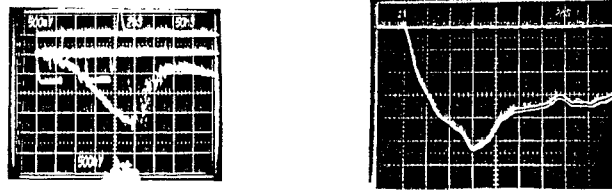

Figure 5. Volumetric flow requirements for switch recovery, flow Configuration B.

Representative voltage waveforms across C1 and C2 are shown in Figure 6. The output voltage of the oil switch is also shown in Figure 6 using the uncalibrated capacitive voltage monitor. Waveforms of the pulse charge voltage on capacitor C1 and C2 were used to check for S1 and S2 switch recovery. As shown in Figure 6, at 100 pps, 0.25 ℓ /sec, the oil switch recovered the full 3 shots. At 200 pps and 0.95 ℓ /sec flow, the oil switch recovered once and S1 did not recover on the second shot. The S1 and S2 recovery problems were associated with gas flow and not oil switch recovery problems^[1]. The waveforms shown are for one test burst. The graph shown in Figure 5 was based on a large number of burst shots.



#165: 100 Hz, 0.25 liter/sec, S3 recovered twice, S1 no recovery 3rd shot.



#182: 200 Hz, 0.95 liter/sec, S3 recovered once, S1 no recovery 2nd shot.

Figure 6. Representative test waveforms, configuration B.

Before concluding the oil switch experiments a quick adaptation of the existing oil switch test stand was made to check the recovery of a sphere/sphere gap ($r = 5.08$ cm, gap = 1.4 mm), with an oil cross-flow pattern (Figure 7). This geometry is important for it is used in many peaking/sharpening switch applications. The oil cross flow was provided by a 1 cm ID tube positioned 7.6 cm from the gap axis (Figure 7). The geometry required a relatively large arc by-product displacement. Nevertheless, 50 pps recovery was obtained on six out of six consecutive three-pulse bursts at 0.32 ℓ /sec, the same as Configuration C and less than a factor of two than the 0.21 ℓ /sec flow required by Configuration B.

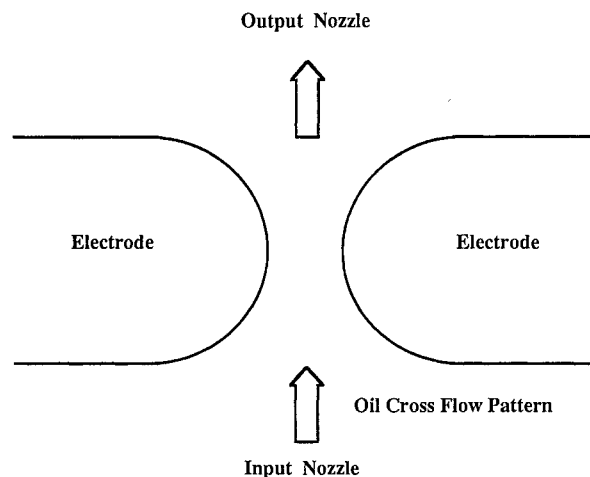

Figure 7. Oil cross flow pattern used for hemispherical electrode/peaking switch geometries.

SUMMARY OF THE OIL SWITCH RECOVERY EXPERIMENTS

During the course of the brief experimental phase, the porous flow used was found not to have any effect upon the oil switch recovery. There are several possible explanations. Perhaps the porous flow velocity was too small to produce significant changes in the nature of the boundary layer, with most of the porous flow being quickly transformed into lateral flow across the surface. More likely, turbulent flow, possibly influenced by surface roughness due to the porous electrode material, dominated the nature of the boundary layer. Many of these effects are amenable to analytic and computer simulations, however this has not been done.

The radially-inward, axially-outward symmetrical flow provided the fastest recovery for a given bulk oil flow. This is consistent with this flow configuration requiring less oil motion for the breakdown products/bubbles to clear the high electric field region. Conversely the radially outward flow performed the worst due to the slowly falling electric field which required a large arc by-product displace-

ment and a rapidly increasing cross-sectional area, which caused a rapid decrease in flow velocity.

The ability of the oil switch to operate at higher repetition rates increased in proportion to the volumetric oil flow rate up to a point where cavitation in the switch region set a limit. The minimum cross-sectional area in the flow loop is at minimum pressure (Bernoulli's Principle)--similarly, the maximum cross-section is at maximum pressure. Thus, as the liquid flows radially inward into a decreasing cross-section the velocity increases and the pressure decreases. The peak velocity is conveniently at the point of highest electrical stress, however the pressure is at a minimum, and to maintain electrical insulation this pressure must not fall to (or even approach) the vapor pressure of the liquid. This effect set the limit on this experiment.

To increase the performance of this type of switch it is clearly desirable to pressurize the flow loop to raise the maximum velocity in the switch gap region prior to cavitation. In order to minimize the required pressure increase for a given flow rate and repetition rate, the cross-sectional area mismatch in the flow loop should be minimized.

SUBNANOSECOND RISE, HIGH REPETITION RATE TEST STAND

To demonstrate the applicability of flowed oil switches for continuous and burst mode operation, a thyatron-switched modulator was built to allow pulse charging of oil switches. The modulator was specifically designed to explore a wide parameter range including operation of oil switches up to 2000 pps and 500 kV. Concurrently the program goals included demonstration of three types of oil switches: (1) a transfer switch, (2) a sharpening switch, and (3) a peaking/sharpening switch. Emphasis was also placed on demonstrating the generation of subnanosecond risetimes with these oil switch geometries. Program funding and schedules limited testing, however test results to date are reported along with a discussion of the experiments.

The simplified system circuit is shown in Figure 8. A hollow-anode thyatron is used to discharge a 360 nF capacitor comprised of ceramic capacitors into the primary of transformer T1. The high voltage transfer capacitor and the multi-kilovolt oil transfer switch are pulse charged in about 1.2 μ sec. The transfer capacitor C_{TRAN} was designed to operate at up to 600 kV, 2000 pps and is constructed from graded ceramic capacitor stacks connected in series and parallel. During the rise of the voltage on C_{TRAN} the oil transfer switch (Figure 8) self-breaks pulse charging a 3 ohm, 0.9 nF water coaxial capacitor and a sharpening switch (output oil switch). Both the output oil switch and the coaxial water capacitor are pulse charged to peak in about 50 nsec, although during actual operation

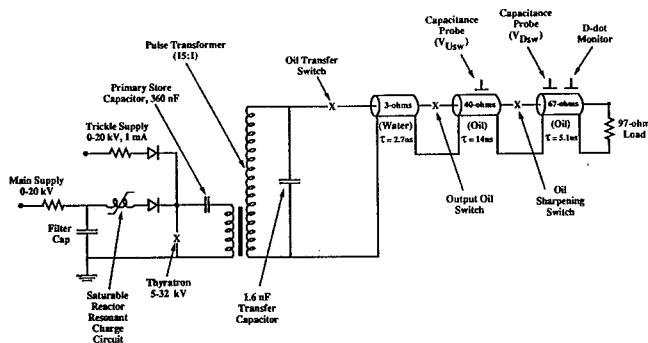

Figure 8. Simplified system circuit of modulator and subnanosecond high repetition rate test stand.

the output oil switch self-breaks in about 35-40 nsec. Once the output oil switch self-breaks, a pulse with a 0.6-0.8 nsec risetime is propagated down the 40 ohm oil line. The leading edge of the pulse doubles in voltage until the oil sharpening switch self-breaks in a few nsec, launching a pulse into the 67 ohm output with a 1/e decay time of 60 nsec, and a risetime of 0.28 nsec.

The transfer switch was designed to operate at a peak voltage 325 kV and to self-break at about 90% of peak amplitude. The transfer switch design takes advantage of the polarity effect in oil and is shown in Figure 9. The switch is mounted in the modulator tank atop the transfer capacitor, C_{TRAN} . The negative output of the transformer pulse charges the convex electrode of the switch. The convex and concave electrodes have radii of 3.81 cm and 4.5 cm respectively. The electrode spacing is externally adjustable. Oil is injected cylindrically around the convex electrode and is extracted axially through both the convex and concave electrodes, (Figure 9). The oil flow rate for the switch was calculated from the results of the phase one experiments. Budgetary constraints set the pump size at the flow rate required for 400 pps operation although a rep-rate of 1250 pps was actually achieved. Two pumps were used for the transfer switch. A high flow rate pump of 7.57 ℓ /sec was used to achieve flow through the 9.5 mm diameter electrode holes. Concurrently a gear pump was used to pressurize the oil flow loop to 2×10^7 Pa (200 psi) to prevent cavitation at the high flow rate.

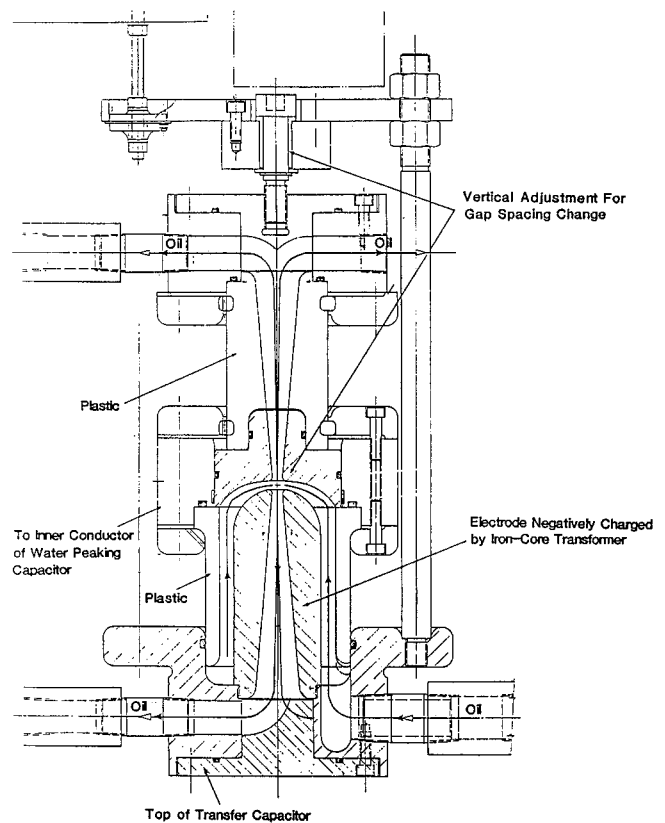

Figure 9. Transfer switch showing oil flow patterns.

The output oil switch is shown in Figure 10. the output oil switch is located between the 3 ohm coaxial water capacitor and the 40 ohm coaxial oil line. The switch is coaxial in construction with provisions for external adjustment. A 9.5 mm hole is provided in each electrode for flow. Oil flow is injected radially and is extracted axially down the center of both electrodes (Configuration B, Figure 1) as shown in Figure 10. The negatively pulse charged electrode has a radius of 20.32 cm. The opposing electrode has a 5.7 cm radius hemisphere. A separate 5 horsepower pump was used to

provide a flow rate of 4.4 ℓ /sec. To avoid cavitation the output switch flow loop is pressurized to 6×10^6 Pa (60 psi).

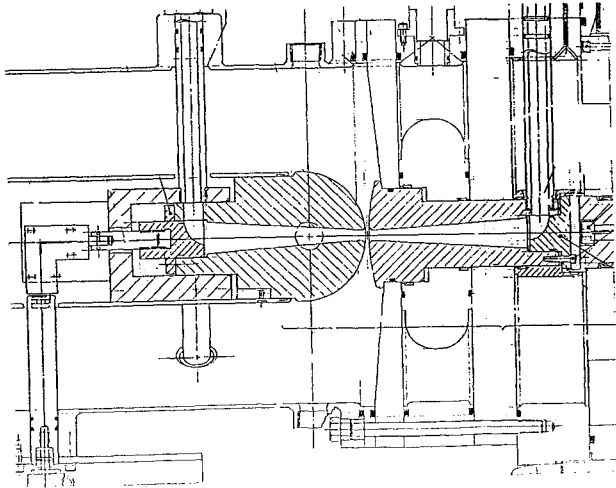

Figure 10. Output switch.

The sharpening switch geometry is radically different from that of both the transfer switch and the output switch. The sharpening (peaking) switch is constructed from two hemispherical electrodes 0.32 cm in diameter, as shown in Figure 11. The sharpening switch is embedded in a bicone geometry which transitions from the 40 ohm coax line to the 67 ohm output line. Oil flow is provided in a cross flow pattern similar to that of Figure 7. Oil flow is injected through a 9.5 mm orifice at a flow rate of 1.9 ℓ /sec. To prevent cavitation, the oil flow loop is pressurized to 6×10^6 Pa (60 psi).

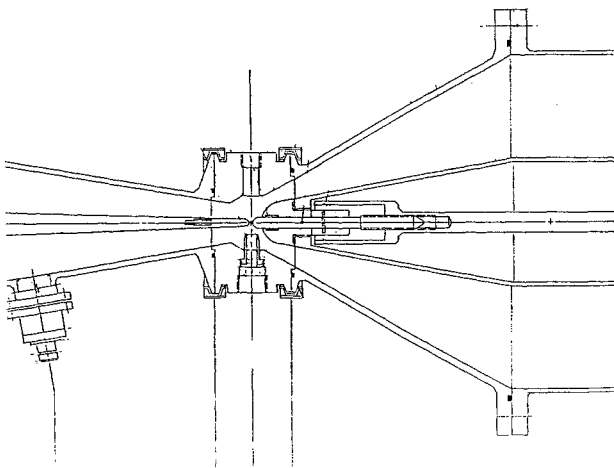

Figure 11. Sharpening switch shown in bicone transition.

The resistive load which terminates the 67 ohm line is 97 ohms in impedance. The load was constructed using a radial coaxial flowed sodium thiosulfate water resistor. The water resistor is about 5 mm thick to limit electromagnetic diffusion effects. The electrolyte load solution is flowed at 1.6 ℓ /sec to remove heat at the peak 50 J/pulse test energy. A photograph of the modulator tank and transmission lines are shown in Figure 12.

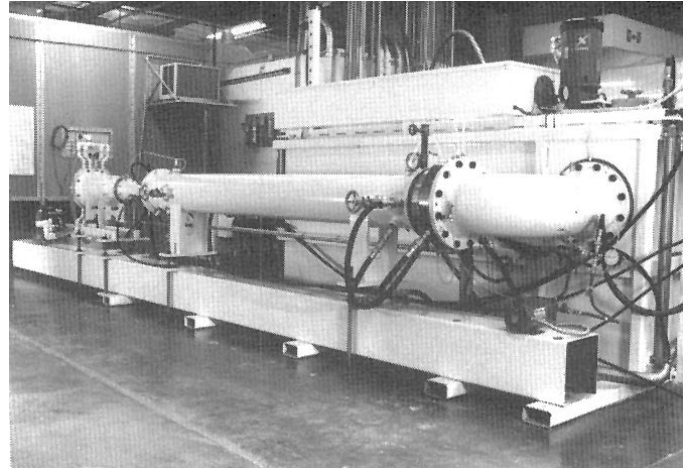

Figure 12. Subnanosecond rise, high rep-rate test stand.

SUBNANOSECOND RISE, HIGH REPETITION RATE EXPERIMENTAL TESTS

A wide parameter range of tests were conducted with the high rep-rate test stand. Subnanosecond risetimes into the 97 ohm load were demonstrated from 140-290 kV with respective rep-rates of 200-1250 pps (Table 1). Thyatron heating and latchup problems prevented continuous operation of the modulator but a large number of burst mode tests were obtained. Concurrent voltage variation due to modulator power supply droop prevented long burst mode operation above about 800 pps. The respective load voltage along with the duration of the burst mode operation is shown in Table 1. At burst mode operation above 800 pps modulator-power supply droop was on the order of 57% contributing to switch closure jitter and slight risetime variation. Budget and schedules did not allow for optimization of the modulator and power supply.

Table 1. Experimental test rep-rates and burst durations.

Output Load Voltage (97 ohms) (kV)	Pulse Rep-Rate (Hz)	Burst Duration (Shots)	Average Energy per Pulse (J)
290	200	≤ 100	50
270	500	≤ 100	---
260	750	≤ 100	---
170	1000	≤ 100	---
140	1250	≤ 100	27.5
200	200	≤ 2000	---
180	500	≤ 2000	---
170	750	≤ 2000	---
160	1000	≤ 2000	26.0

The transfer switch was successfully operated up to 1250 pps without loss of recovery or signs of cavitation. The transfer switch was set to breakdown slightly before peak voltage which occurs at 1.2 μ s on the transfer capacitor, C_{TRAN} pulse charge waveform. During long burst mode operation this allowed for self-closure of the transfer switch even after droop of the pulse charge voltage. The risetime of the transfer switch was circuit inductance limited; not switch limited.

The output switch was found to be one of the limiting switches in the system. Above 4.4 ℓ /sec cavitation occurred, preventing recovery of the switch in the interpulse interval at rep-rates on the order of 1250 pps. During the parameter scan the switch was operated over the spacing range 0.07 to 0.25 cm. The average breakdown strength over the tests ranged between 1 and 1.2 MV/cm. Typically, the breakdown voltage varied tens of percent during the burst, and the higher breakdown field values corresponded approximately with the single pulse breakdown fields expected for lightly field enhanced, $\sim 1 \text{ cm}^2$ electrodes in still oil, charged in about 35-40 nsec. Electrode arc patterns indicated that the arcs in fact occurred not on the lightly field enhanced regions, which are the edges of the holes through which oil exits the gap, but in the relatively flat electrode regions a few millimetres outside.

The output switch risetime was monitored with V_{USW} , a capacitive probe located in the 40 ohm coaxial oil line. The capacitive probe was placed 25 cm upstream of the bicone-sharpening switch transition, effectively transient time isolating the probe from impedance reflections which occur at the bicone transition. A representative waveform of the risetime of V_{USW} is shown in Figure 13. The observed risetime of the output switch was in the 0.6-0.8 nsec range when displayed on a Tektronix 7104. This was somewhat unexpected, based on resistive phase calculations. Note also that the pulse tends to "double" in amplitude before the sharpening switch self-breaks.

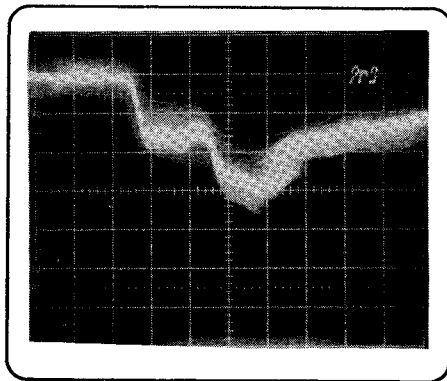

92.5 kV/div
2 nsec/div

Average voltage on the load ~ 170 -180 kV

Figure 13. V_{USW} capacitive probe signal during a 750 pps, 1000 shot burst.

The inductive output switch risetime of even the longest output switch arc channel (0.25 cm) in the 43 ohm circuit formed by the 40 ohm output oil line and the 3 ohm water capacitor is only $2.2 \times 15 \text{ nH/cm} \times 0.25 \text{ cm}/43 \approx 0.2 \text{ nsec}$ (10 - 90%), which is negligible. The resistive phase given by J.C. Martin's formulae, Equation 1, is 1.7-2.2 nsec for the 1 to 1.2 MV/cm range of mean breakdown fields observed. The observed 0.6-0.8 nsec risetime indicates that the resistive phase is considerably less than predicted, especially recognizing that the radial transit time of the wave across the oil coax may contribute a few tenths of a nanosecond to the risetime.

It should also be mentioned that at higher rep-rates oil temperature appeared to affect switch recovery. As the temperature of the oil increased switch recovery appeared to improve. This has been attributed to the decreasing viscosity of the oil at elevated temperatures. This effect was also noted in the sharpening switch.

Although the output switch limited repetition rate due to cavitation, the sharpening switch was also found to affect the repetition

rate and voltage output of the modulator. At high pulse repetition rates, 800 pps or above, the sharpening switch spacing had to be reduced to insure recovery of the switch. This is what limited the load voltage to 290 kV or below. This effect has been attributed to the cross flow pattern used in the oil switch.

Risetimes a factor of two-three less than the output switch risetime were observed into the 97 ohm load. The load voltage risetime was measured with a B&H modified Tektronix 7104 oscilloscope (2 GHz bandwidth) and a D-dot probe located downstream from the sharpening switch (Figure 8). The load voltage was also estimated using a capacitive probe (V_{DSW}) and the transmission coefficient of the 67 ohm line into the 97 ohm load. The capacitive probe was displayed on a 7104 (1 GHz bandwidth) oscilloscope. Representative capacitive voltage monitor and D-dot signals are shown in Figure 14 for a 750 pps burst at 170 kV load voltage. The computer integrated combination D-dot/oscilloscope risetime was typically 0.34-0.35 nsec, Figure 15. The B&H 7104 risetime is about 0.2 nsec so the switch risetime estimated by quadrature subtraction is about 0.28 nsec.

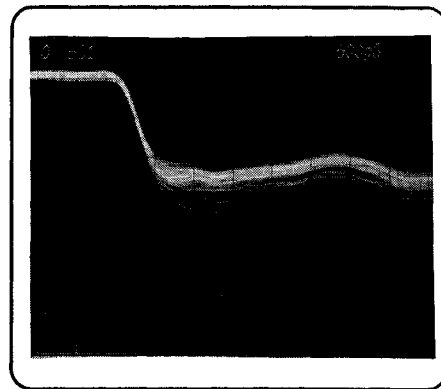

Capacitive monitor, V_{DSW} , signal showing load voltage into 97-ohm load (68.4 kV/div; 500 ps/div)

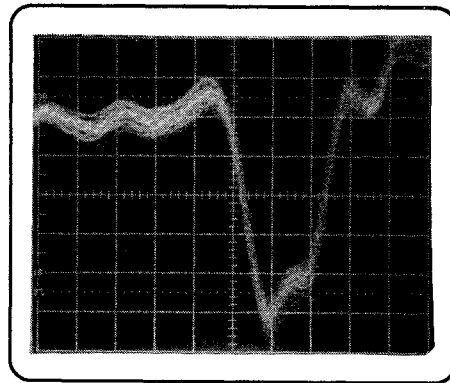

Sharpening switch B-dot signal showing risetime of the sharpening switch

Figure 14. Representative load voltage and risetime waveforms at 750 pps, 100 shot burst.

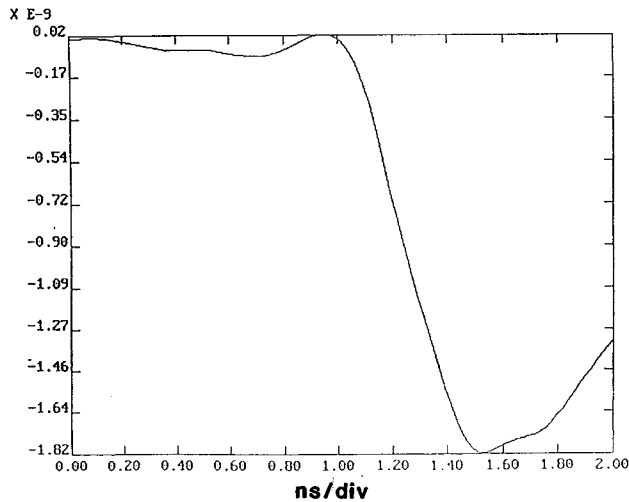

Figure 15. Integrated D-dot signal of load voltage and risetimes showing the 10-90% risetime of .34 nsec of the sharpening switch and oscilloscope. Deconvolved risetime into the load is .28 nsec.

The closure time of the sharpening switch varied with machine setting from about 1-4 nsec after arrival of the pulse from the output switch. Since the nearest voltage monitor upstream was separated from the switch by a 2.5 nsec round trip, the exact switch voltage waveform could only be estimated; the estimated value of t_{eff} , the time above 63% of peak voltage, varied from 1-3 nsec. Spacings varied from about 0.02-0.1 cm nominally; because of the small absolute spacings and the possible movement under oil flow pressure, these spacings are not known to better than 20%.

Estimating the electric field on the positive (downstream) switch electrode from its original shape with radius 0.32 cm, the breakdown fields on the surface were in the range 3.5 - 5 MV/cm and the value of $Ft^{1/3}$ was in the range 0.4-0.6 (MV/cm, μs), for most of the machine settings. Again, this value is the average over the burst, and the maximum values are somewhat higher. For an effective area of $\leq 0.1 \text{ cm}^2$, the prediction for the single-shot strength in still oil is $Ft^{1/3} \approx 0.6$. This is in agreement within the accuracy of the measurements of spacing and t_{eff} ; additional uncertainty is introduced into the field enhancement by the fact that the positive electrode eroded during operation from its initial 0.32 cm radius hemisphere to an almost flat surface with smaller radius edges. A total of 370,000 shots were taken over the course of the experiments.

The sharpening switch like the output switch has a negligible inductive risetime even with the longest 0.1 cm channel. The radial transit time is also vary small in this region. The mean breakdown field was in the range 3.5 to 5 MV/cm, and the resistive phase given by the formula, Equation 1, used above with $Z = 107 \text{ ohms}$ (the sum of the 40 ohm upstream and 67 downstream impedances) is 0.2-0.33 nsec 10-90%. Slightly shorter risetimes might be expected because of the peaking effect of the lowered line impedance just upstream of the switch.

The calculated 0.2-0.33 nsec resistive phase risetime, and the corrected measured risetime of 0.28 nsec is in good agreement.

CONCLUSIONS

Experiments have shown the applicability of using flowed oil switches to produce subnanosecond risetime pulses at kilohertz rep-

rates. The compactness of the oil system when compared to flowed gas spark gaps, make flowed oil systems a desirable candidate for high rep-rate systems requiring risetimes less than a microsecond, or even a nanosecond. Higher repetition rate oil systems are also quite likely based on our experimental data. Although the oil systems were sized for 400 pps operation, 1250 pps operation was achieved. Thus the graph of the required flow rates versus rep-rate in Figure 5 is somewhat pessimistic. Utilizing lower viscosity oils or liquids or even larger pumping systems may result in liquid dielectric switches capable of operating at 4-10 kHz. Lower energy systems can also be made quite a bit more compact especially when the closed loop flow characteristics of oil systems are considered. Thus liquid based switches may offer an attractive option for future compact subnanosecond risetime applications.

REFERENCES

- [1] P. D'A. Champney, J. Fockler, R. Curry, R.W. Conrad, "High Repetition-Rate, High-Power, Fast Closing Oil Switch," Megagauss V Conference, Novosibirsk, Russia, 1989.