

NUWC-NPT Reprint Report 10,766
15 May 1997



Biased Lead Zirconate-Titanate as a High-Power Transducer Material

Mark B. Moffett
James M. Powers
Robert S. Janus
Elizabeth A. McLaughlin
Submarine Sonar Department



UNCLASSIFIED
NAVAL UNDERSEA WARFARE CENTER
DIVISION NEWPORT
NEWPORT, RHODE ISLAND 02841-1708
RETURN TO: TECHNICAL LIBRARY

**Naval Undersea Warfare Center Division
Newport, Rhode Island**

Approved for public release; distribution is unlimited.

Reprint of a presentation made at the 1997 *ONR
Transducer Materials and Transducers Workshop*,
29 April-1 May 1997, University Park, PA.

Report Documentation Page

Form Approved
OMB No. 0704-0188

Public reporting burden for the collection of information is estimated to average 1 hour per response, including the time for reviewing instructions, searching existing data sources, gathering and maintaining the data needed, and completing and reviewing the collection of information. Send comments regarding this burden estimate or any other aspect of this collection of information, including suggestions for reducing this burden, to Washington Headquarters Services, Directorate for Information Operations and Reports, 1215 Jefferson Davis Highway, Suite 1204, Arlington VA 22202-4302. Respondents should be aware that notwithstanding any other provision of law, no person shall be subject to a penalty for failing to comply with a collection of information if it does not display a currently valid OMB control number.

1. REPORT DATE 15 MAY 1997		2. REPORT TYPE Reprint Report		3. DATES COVERED 29-04-1997 to 01-05-1997	
4. TITLE AND SUBTITLE Biased Lead Zirconate-Titanate as a High-Power Transducer Material				5a. CONTRACT NUMBER	
				5b. GRANT NUMBER	
				5c. PROGRAM ELEMENT NUMBER	
6. AUTHOR(S) Mark Moffett; James Powers; Robert Janus; Elizabeth McLaughlin				5d. PROJECT NUMBER	
				5e. TASK NUMBER	
				5f. WORK UNIT NUMBER	
7. PERFORMING ORGANIZATION NAME(S) AND ADDRESS(ES) Naval Undersea Warfare Center, Division Newport, 1176 Howell Street, Newport, RI, 02841-1708				8. PERFORMING ORGANIZATION REPORT NUMBER RR 10,766	
9. SPONSORING/MONITORING AGENCY NAME(S) AND ADDRESS(ES)				10. SPONSOR/MONITOR'S ACRONYM(S)	
				11. SPONSOR/MONITOR'S REPORT NUMBER(S)	
12. DISTRIBUTION/AVAILABILITY STATEMENT Approved for public release; distribution unlimited					
13. SUPPLEMENTARY NOTES NUWC2015 Reprint of a presentation made at the 1997 ONR Transducer Materials and Transducers Workshop, 29 April-1 May 1997, University Park, PA.					
14. ABSTRACT In considering applications for high-power, electrostrictive transducer materials such as lead magnesium niobate, one should not overlook the possibility of biased operation of conventional high-power materials, such as Navy Type III lead zirconate-titanate (PZT). Because of the high electrical impedance of this material, very large electric fields will be required, with concomitant transducer design problems, but 10-dB increases in energy density (over that obtainable with conventional, unbiased Type III piezoceramic) might be achievable. Measurements of the strain and charge density for prestressed samples of Type I and Type III, subjected to compressive prestress up to 10 ksi and peak electric field intensities as much as 2 MV/m, indicate substantial increases in the relative permittivity ϵ_{33} T_{fe0}, with increasing bias field. On the other hand, the elastic compliance coefficient s_{33E} and the piezoelectric strain coefficient d_{33} do not deviate greatly from their small-signal values. Therefore, the energy density may be expected to increase in a roughly proportional manner to the square of the ac drive field intensity. However, the coupling factor k_{33} would be expected to decrease with increasing bias field (because of the increasing permittivity), and so the bandwidth obtainable from biased PZT will be reduced from that of conventionally driven material.					
15. SUBJECT TERMS High-Power Transducer; Biased Lead Zirconate-Titanate					
16. SECURITY CLASSIFICATION OF:			17. LIMITATION OF ABSTRACT	18. NUMBER OF PAGES	19a. NAME OF RESPONSIBLE PERSON
a. REPORT unclassified	b. ABSTRACT unclassified	c. THIS PAGE unclassified			

Biased Lead Zirconate-Titanate as a High-Power Transducer Material*

Mark B. Moffett

James M. Powers

Robert S. Janus

Elizabeth A. McLaughlin

Naval Undersea Warfare Center Division, Newport, RI 02841

Abstract

In considering applications for high-power, electrostrictive transducer materials such as lead magnesium niobate, one should not overlook the possibility of biased operation of conventional high-power materials, such as Navy Type III lead zirconate-titanate (PZT). Because of the high electrical impedance of this material, very large electric fields will be required, with concomitant transducer design problems, but 10-dB increases in energy density (over that obtainable with conventional, unbiased Type III piezoceramic) might be achievable. Measurements of the strain and charge density for prestressed samples of Type I and Type III, subjected to compressive prestress up to 10 ksi and peak electric field intensities as much as 2 MV/m, indicate substantial increases in the relative permittivity $\epsilon_{33}^T/\epsilon_0$, with increasing bias field. On the other hand, the elastic compliance coefficient s_{33}^E and the piezoelectric strain coefficient d_{33} do not deviate greatly from their small-signal values. Therefore, the energy density may be expected to increase in a roughly proportional manner to the square of the ac drive field intensity. However, the coupling factor k_{33} would be expected to decrease with increasing bias field (because of the increasing permittivity), and so the bandwidth obtainable from biased PZT will be reduced from that of conventionally driven material.

*The work reported here was supported by the Office of Naval Research (Code 332).

Introduction

The use of electrically biased lead zirconate-titanate (PZT) is not a new idea, but it has often been ignored as a method for obtaining high power densities in piezoelectric transducers. Presumably, the reason for this neglect has been the relative simplicity of unbiased operation. However, the newer, higher powered materials, such as lead magnesium niobate (PMN), are electrostrictive and, therefore, require electrical biasing. So, as long as we are planning to go to the trouble of providing the bias, it seemed worthwhile to take another look at biased operation of PZT.

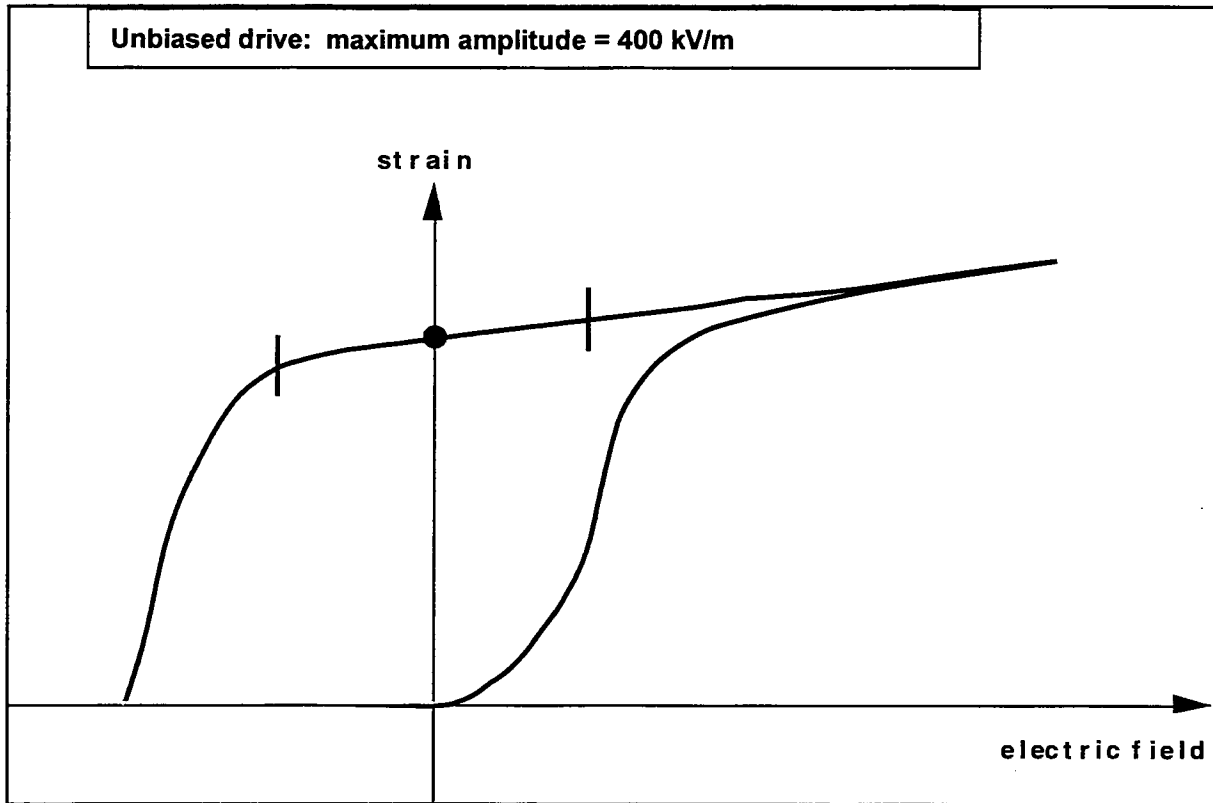

Strain vs EField, Unbiased Drive

This viewgraph represents the polarization of a piezoceramic material, such as PZT. After polarization, the remanent strain, indicated by the black dot, is at the center of a linear-response portion of the curve. We can safely drive the material between the limits shown without depolarizing the material. Experience has shown that a safe rms drive amplitude for PZT-8 (i.e., Navy Type III material) is 400 kV/m (10 V/mil). Exceeding this limit in the direction opposite to the polarization direction (i.e., to the left in this plot) takes us into a nonlinear region and eventually, as the coercive field is reached, to complete depolarization.

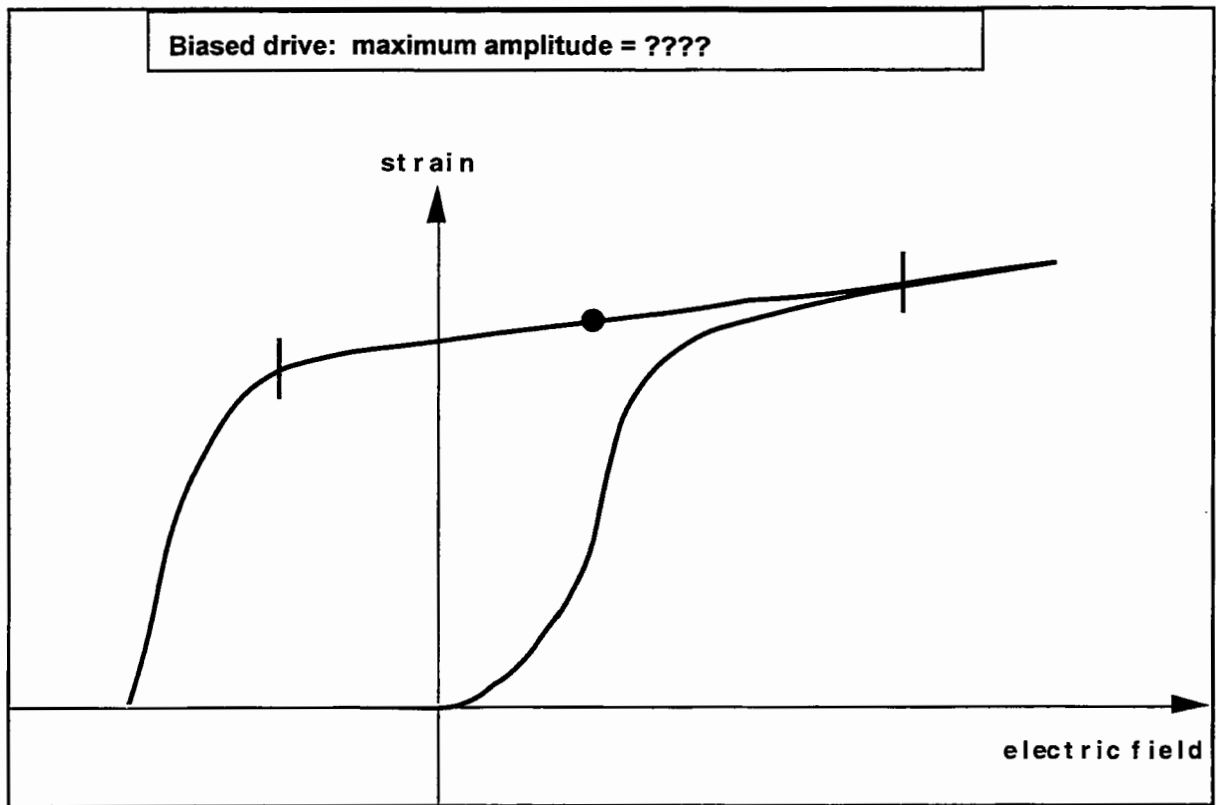

Strain vs E Field, Biased Drive

There is a substantial linear region in the positive, or polarization direction, however. The field in this direction can be much larger than in the negative direction. In this case, we have introduced a dc bias field, indicated by the black dot, around which the ac field oscillates symmetrically. Of course, there must be some practical limit as to how far you can go with this approach, and we're not sure of the answer yet, but it is clear that increased drive levels are possible with biasing.

Three material parameters importance for projectors

-- electromechanical energy density
field-limited radiated

$$U_f = k_{33}^2 \epsilon_{33}^T E_{rms}^2$$

-- short-circuit mechanical energy
determines stress-limited radiated

$$U_s = s_{33}^E T_{rms}^2$$

-- electromechanical coupling factor
bandwidth

$$k_{33} = d_{33} / (\epsilon_{33}^T s_{33}^E)^{1/2}$$

Three Material Parameters of Importance for Projectors

There are three parameters of importance to projector designers and, in our enthusiasm for enhancing one of them, we must be careful not to degrade the others. The field-limited radiated power is determined by the electromechanical energy density, which is the material coupling factor squared multiplied by the electrical energy density at constant stress, i. e., the product of the constant-stress permittivity and the square of the rms electric field amplitude. It is this quantity that can be substantially increased by biasing, because we can increase the rms field.

The stress-limited radiated power is determined by the mechanical energy density, given by the constant-field compliance coefficient multiplied by the limiting rms stress amplitude. This limiting stress is determined by the amount of compressive pre-stress that can be applied to the piezoceramic material. For PZT-8 pre-stressed to 6 kpsi, we take the limiting stress amplitude to be 6 kpsi zero-to-peak, thereby avoiding tension in the ceramic. This 6-kpsi peak corresponds to 4.2 kpsi rms, or 29 MPa rms amplitude.

In addition to the field and stress limits, the material coupling factor itself is also important, because it determines the bandwidth over which the impedance variation of the transducer is within certain bounds, so that a reasonably sized drive amplifier can be used.

	Unbiased PZT-4	Biased PZT-4	Unbiased PZT-8	Biased PZT-8	PMN- PT 1% La	PMN- PT 3% Ba	Terfenol- D
density(kg/m ³)	7500		7600		7800		9100
s_{33}^E (pm ² /N)	15.5		13.5		12.7	11.4	34.5
s_{33}^H (pm ² /N)							
$\epsilon_{33}^T/\epsilon_0$	1300		1000		13000	12000	4.3
μ_{33}^T/μ_0							
d_{33} (pm/V)	290		225		515	400	9.1
(nm/A)							
k_{33}	0.68		0.65		0.42	0.36	0.67
T_{dc} (MPa)	41		41		41	41	41
T_{rms} (MPa)	29		29		29	29	29
$s_{33}^E * T_{rms}^2$	13		11.5		11	9.7	29
$s_{33}^H * T_{rms}^2$							
(kJ/m ³)							
relative dB wrt unbiased PZT-8	0.6		0.0		-0.3	-0.7	4.1
E_{dc} (MV/m)	0	0.80	0	0.72	1.00	1.00	100
H_{dc} (kA/m)							
E_{rms} (MV/m)	0.28	0.85	0.39	0.91	0.62	0.62	45.0
H_{rms} (kA/m)							
$k_{33}^2 * \epsilon_{33}^T * E_{rms}^2$	0.42	3.9	0.57	3.1	8.0	5.4	4.9
$k_{33}^2 * \mu_{33}^T * H_{rms}^2$							
(kJ/m ³)							
relative dB wrt unbiased PZT-8	-1.3	8.3	0.0	7.4	11.5	9.8	9.3

Material Properties at 6-kpsi Compressive Pre-stress

This tabulation compiles the properties of candidate high-power transducer materials. We have used book values for the PZTs here for both unbiased and biased operation, to get an initial indication of what might be achievable. (We'll show you our test results shortly.) The PMN and Terfenol-D properties have been measured by us in the past. Looking at the material coupling factor k_{33} , we see that PZT and Terfenol are roughly comparable, but PMN is at a disadvantage. Next, look at the stress-limited energy density. The ceramic materials are all roughly comparable, assuming they can handle the same 6-kpsi pre-stress and 29-MPa rms stress amplitude, but Terfenol, because it is a softer material, will provide a 4-dB stress-limit advantage over the ceramics. Finally, looking at the last line, we see that by allowing a peak forward field of 2 MV/m (50 V/mil), we can expect to increase the electromechanical energy density by 7 or 8 dB.

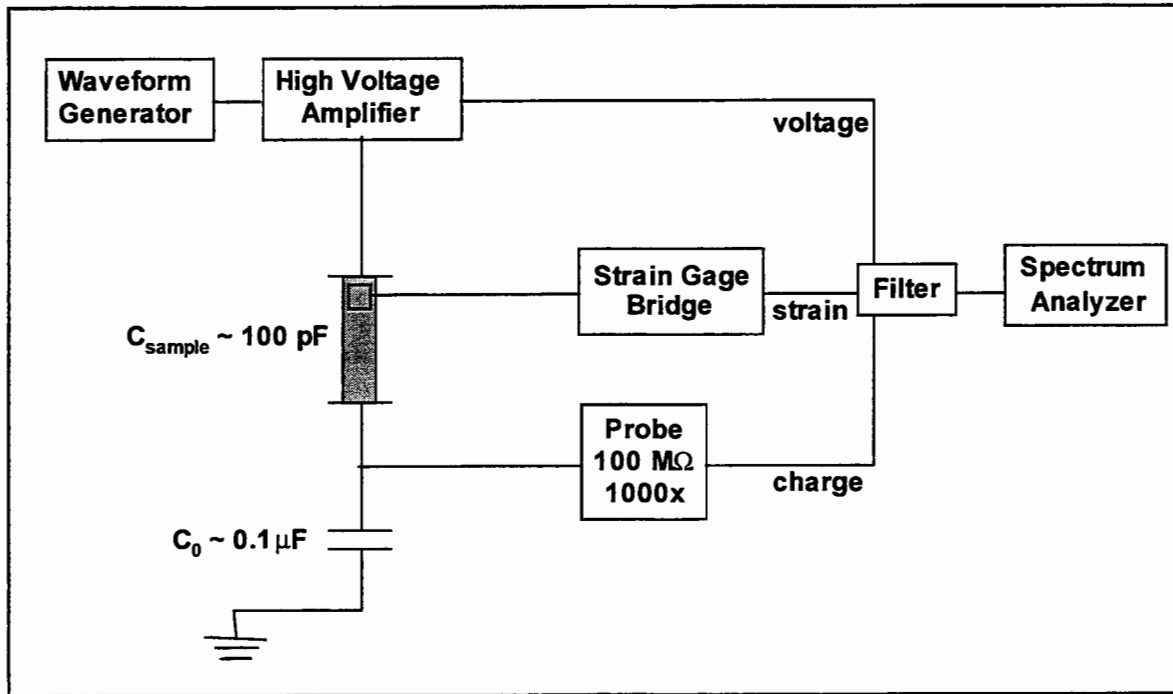

Measurement Circuit

We made quasistatic measurements of the large signal d_{33} and permittivity of a small sample of Edo Corporation's EC-69, i.e., PZT-8 or Navy Type III material. By measuring the strain as a function of applied voltage, we can get the d_{33} coefficient, and by measuring the charge as collected on a large, known, mica capacitor in series with the sample, we can get the permittivity. This viewgraph, however, was originally made to describe our PMN measurements, and the PMN sample capacitances were much larger than those of the PZT-8. Instead of the 100 pF shown on this viewgraph, the PZT number was more like 3 to 9 pF, and so we had to correct for parasitic capacitance, not shown here. Also not shown is the load cell used to measure the compressive load supplied by a pneumatic control system.

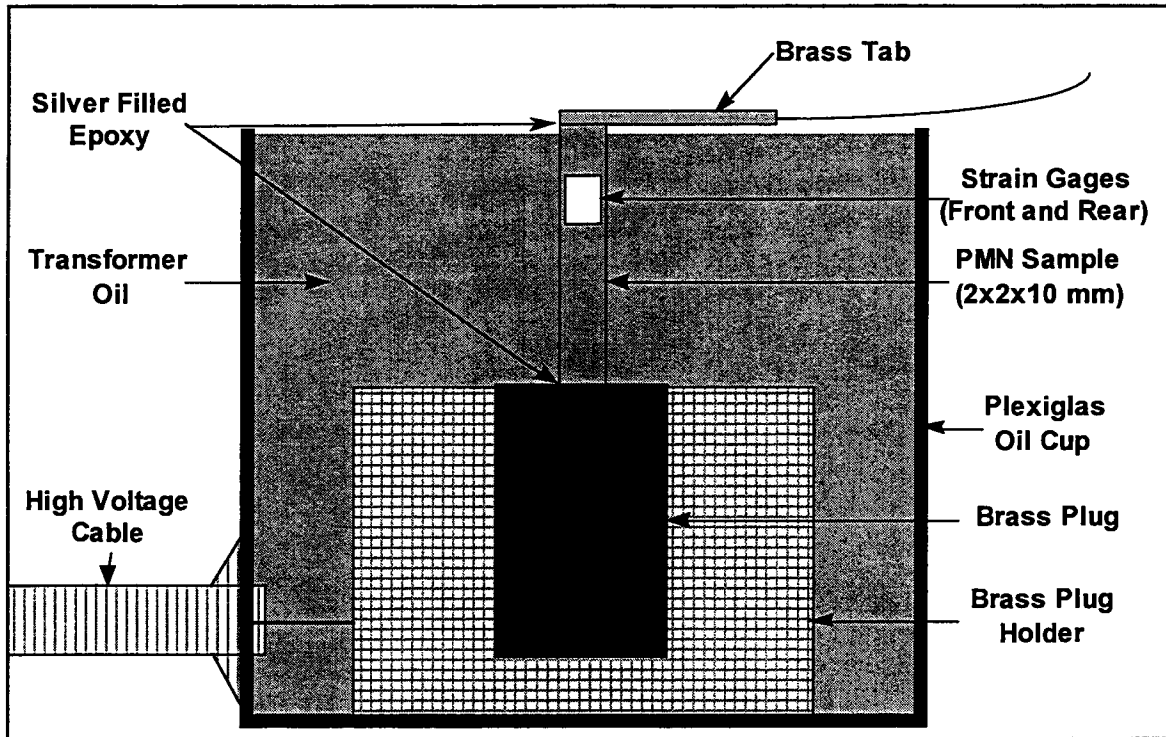

Sample Fixture

This viewgraph shows an enlarged view of the sample fixture. The sample is about 10 mm long with a 2-mm x 2-mm square cross-sectional area. In addition to the d_{33} and permittivity measurements, we also obtain the Young's modulus in the same setup by measuring the strain as a function of the stress for a constant bias voltage.

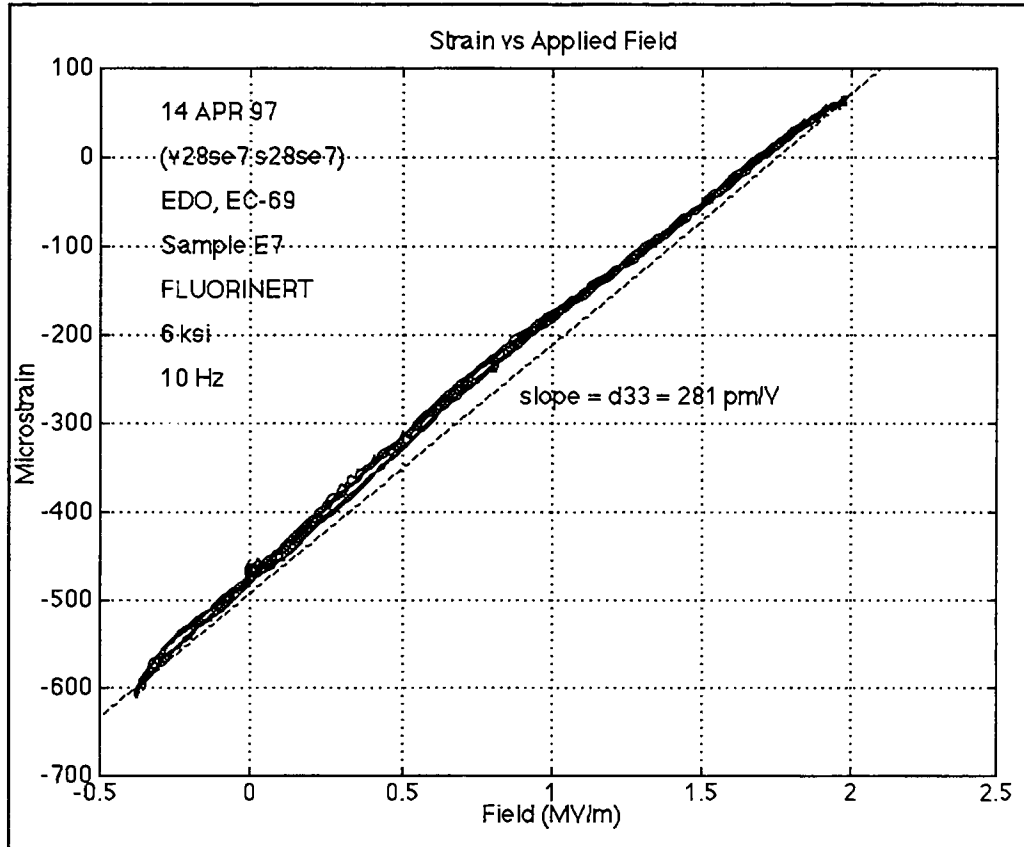

Strain vs Applied Field

This plot shows an example of the d_{33} measurement for a prestress of 6 kpsi. The ac electric field oscillated at 10 Hz between +2 MV/m and -0.4 MV/m. The straight line slope between the two endpoints is what we take to be the large-signal d_{33} , 281 picometers per volt, in this case.

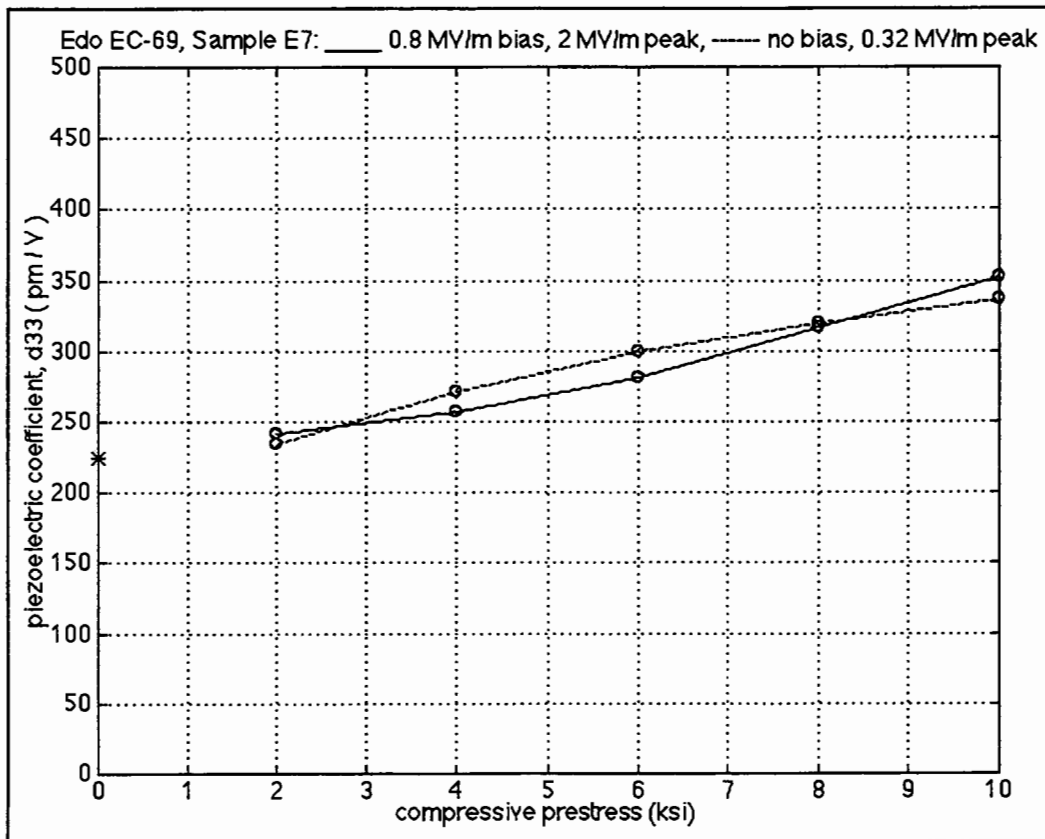

d_{33} vs Pre-Stress

In this plot, the circles indicate our data points with bias (solid lines) and without bias (dashed lines). The star plotted at zero pre-stress indicates the book value, 225 pm/V. Biasing the material apparently does not appreciably change the d_{33} coefficient, but our data do indicate more of an increase with pre-stress than reported in the literature.

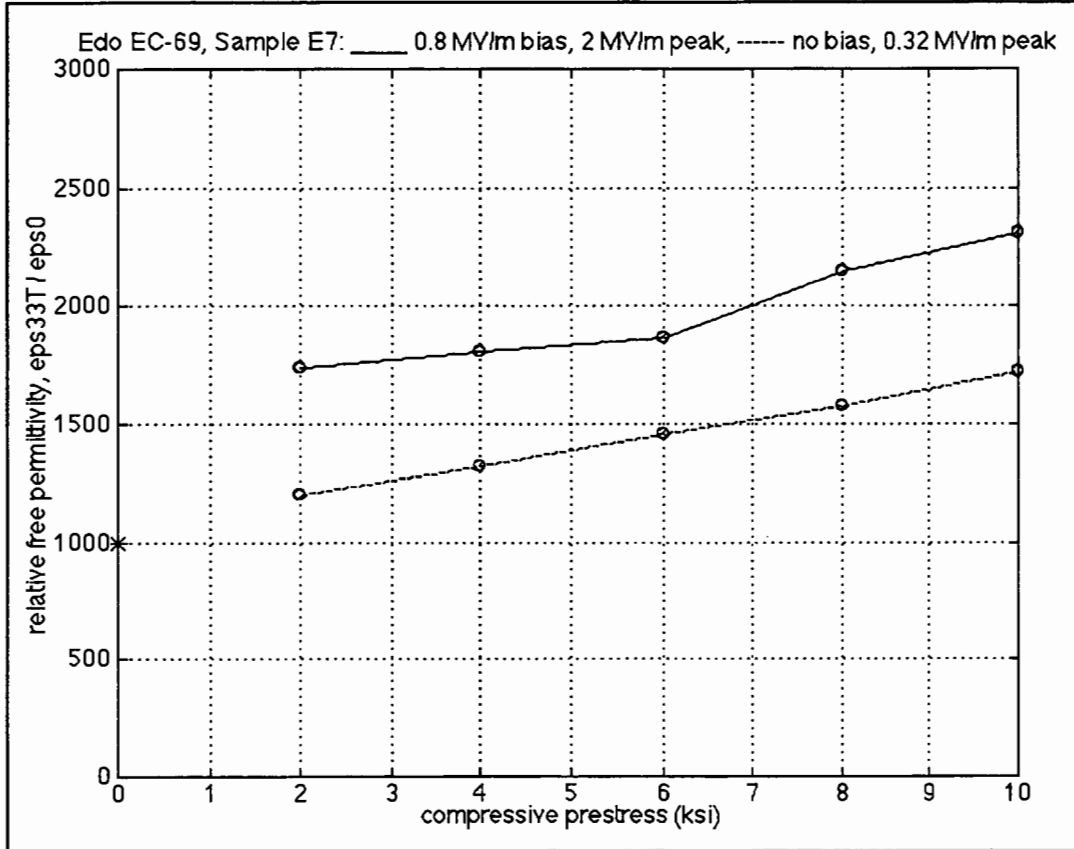

Permittivity vs Pre-Stress

The permittivity also increases with prestress, as is well known, but we also see an increase due to the bias field, as indicated by the difference between the solid and dashed lines. (Again, book value is indicated by the star symbol.) Because the parasitic capacitance was almost as large as that of the sample, the correction for it was substantial, and we would like to improve our accuracy for measuring PZT permittivities before inferring too much from these data.

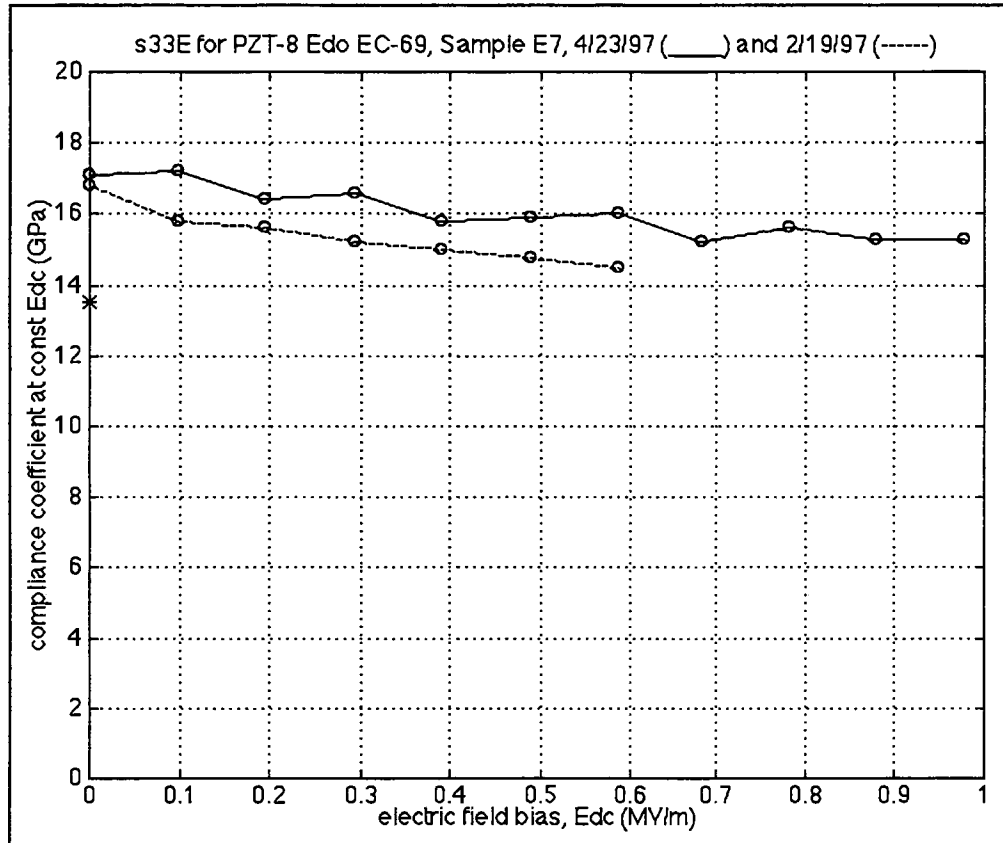

s_{33}^E vs Bias Field

This plot shows the compliances (reciprocal Young's moduli) as a function of the bias field. The two sets of data (solid and dashed lines) were taken before and after moving our laboratory from Connecticut to Rhode Island and could be an indication of random error. There is a systematic error, also, due to the fact that the strain gauges are mounted on Kapton insulating tape and, therefore, tend to measure slightly less strain than they should. The measured compliances are about 20 percent above the book value, 13.5 picometers-squared per newton, as indicated by the star plotted at zero bias. The measurements suggest a slight decrease, if anything, with increasing bias.

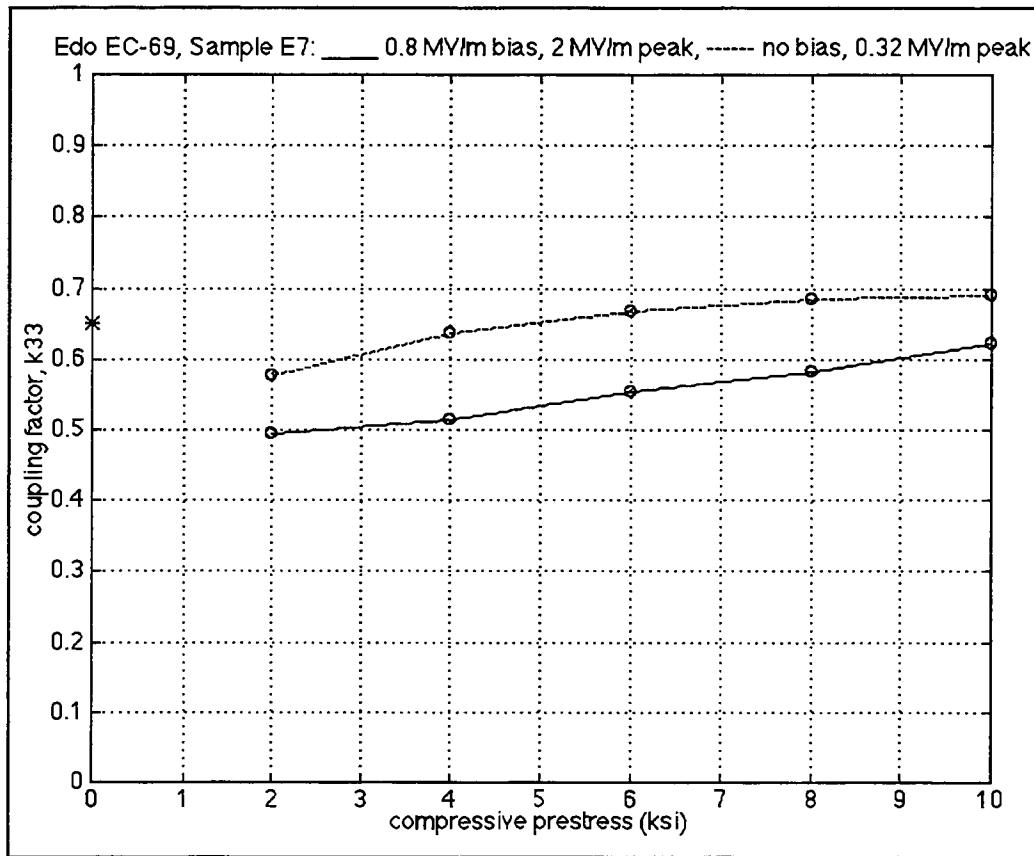

k_{33} vs Pre-Stress

The material coupling factor was calculated from the compliance, permittivity, and d_{33} measurements. Because our measured permittivity increased when we applied the bias field, the k_{33} coupling factor shows a decrease with bias, as indicated by the difference between the dashed and solid lines. This would be a drawback for biased operation, because it would entail a reduced bandwidth, about 10 percent, according to our data.

	Unbiased PZT-8		Biased Materials	
	Book Value	Measured Vale	PZT-8	PMN-PT 1% La
density(kg/m ³)	7600			7800
s_{33}^E (pm ² /N)	13.5	17	16	13
$\epsilon_{33}^T/\epsilon_0$	1000	1500	1900	13000
d_{33} (pm/V)	225	300	280	515
k_{33}	0.65	0.69	0.59	0.42
T_{dc} (MPa)	41			
T_{rms} (MPa)	29			
$s_{33}^E * T_{rms}^2$ (kJ/m ³)	11.5	14	13	11
relative dB wrt unbiased PZT-8	0.0	0.9	0.6	-0.3
E_{dc} (MV/m)	0		0.80	1.00
E_{rms} (MV/m)	0.39		0.85	0.62
$k_{33}^2 * \epsilon_{33}^T * E_{rms}^2$ (kJ/m ³)	0.57	0.81	3.6	8.0
relative dB wrt unbiased PZT-8	0.0	1.6	8.1	11.5

Comparison of PZT-8 and PMN-PT at 6-kpsi Pre-Stress

This viewgraph is a tabulation of our measured values for PZT-8, along with book values for unbiased, unstressed PZT-8 and our previous measurements for PMN-PT with 1 percent lanthanum. The coupling factor for biased-PZT, 59 percent, even though decreased from the unbiased value, is much better than that of PMN, 42 percent. On the other hand, the PMN electromechanical energy density (bottom line of table) is larger than that for biased PZT by more than 3 dB. Still, biasing the PZT provided an 8-dB increase over the book value for the unbiased material.

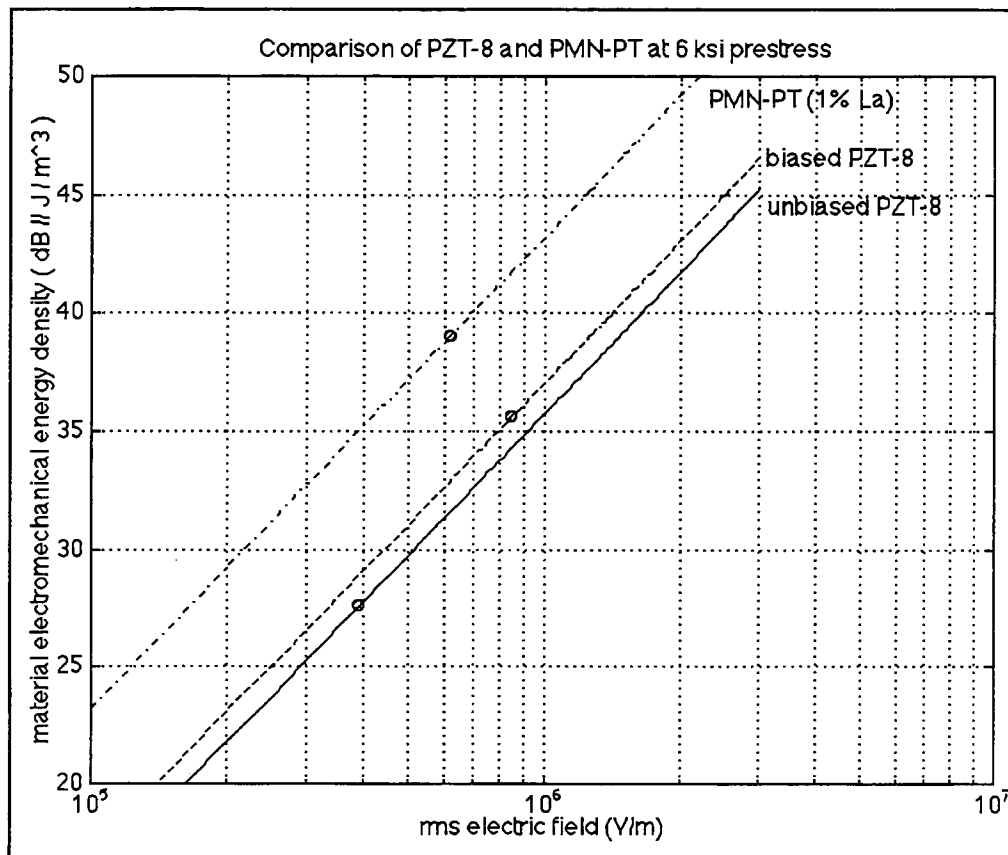

Comparison of PZT-8 and PMN-PT at 6-ksi Pre-Stress

This plot shows the material electromechanical energy density for unbiased PZT-8 as the solid line, biased PZT-8 as the dashed line, and PMN-PT with 1 percent lanthanum as the dashed-and-dotted line. The circle plotted on the solid line is the book value for unbiased PZT-8. The circle on the dashed line (for biased PZT-8) shows the 8-dB increase that we were able to achieve in the laboratory with our 2-MV/m peak electric field. The circle on the PMN-PT line was obtained with the same peak field, but with a somewhat smaller rms amplitude because of the nonlinearity of the PMN response. The 2-MV/m limit, by the way was imposed by the sample geometry and our high voltage amplifier, and so further increases along the dashed line may be feasible if they are needed. In fact, Tom ShROUT shows two plots of his results for driving PZT-8 to beyond 4 MV/m.

Conclusions

- **8 dB increase in electromechanical energy density can be achieved with biased operation of PZT-8**
- **Transducer must be designed to withstand peak field of 2 MV/m (50V/mil)**
- **Bandwidth may decrease by 10 percent**

Conclusions

We have shown that an 8-dB increase in the electromechanical energy density, and hence the field-limited radiated power, can be achieved by biasing PZT-8. The main price one has to pay for this increase is the redesign of the transducer so that higher electric fields can be accommodated. Achieving 8 dB will require peak fields of 2 MV/m (50 V/mil). The other downside of biased operation of PZT is a modest reduction in bandwidth due to a reduced coupling factor, but the coupling factor is still appreciably higher than for PMN.