

A HIGH-POWER
FAST-RESPONSE
SWITCH-TESTING SYSTEM

J. Bernardes
Naval Surface Warfare Center
Dahlgren, VA 22448

Abstract

A high-power, versatile switch-testing system, presently in operation at NSWC-Dahlgren, is described. The switch, along with a liquid-dielectric PFL, a liquid load, a voltage probe, and a current probe are mated in a low-inductance configuration. This arrangement allows the evaluation of switch performance on a nanosecond time scale.

Introduction

Measurement of switch parameters that characterize the "turn-on" phase of a high-power switch (i.e., turn-on time, dI/dt , switch losses) requires the use of a switch-testing system that is capable of delivering a fast-rising pulse to the switch, and at the same time can measure switch voltages and currents with transient times of a few nanoseconds. The above two requirements dictate that the pulser, the switch under test, and the diagnostics be configured in a low inductance geometry.

The switch testing system described in this paper satisfies the above requirements by using a liquid-dielectric pulse forming line (PFL), in conjunction with diagnostics that consist of a resistive/capacitive-divider voltage probe, a B-dot loop current probe, and a current-viewing resistor (CVR). This system is based on a design originally developed at Los Alamos National Laboratory, by J. Power and W. Willis, in the mid-seventies.

Test-Apparatus

A cross-section view of the test-apparatus is shown in Figure 1. The PFL design is the key to the low-inductance configuration of the system. The PFL consists of three concentric, aluminum tubes of varying diameter (O.D. = 26.67, 30.48, 34.29 cm respectively), but all roughly 1 m in length. When charged, the center tube of the PFL rises to a high potential, and the inner and outer tubes, which are electrically connected at both ends of the PFL, remain at ground potential. The dielectric liquid is contained between the inner and outer tubes, allowing access to the switch under test from the inside of the PFL. This system can accommodate switches with diameters up to 15 cm, and as tall as 1 m. The circuit load is a ~1-ohm, cylindrical, soap-solution resistor that connects the center tube of the PFL to the high-voltage side of the switch under test. The PFL connection is made through a symmetrical four-point contact using a compressible, beryllium-copper, finger-stock material. This same material is used around the perimeter of the switch base to make the switch-load contact. A cylindrical current-viewing resistor (CVR), located above the switch, measures the switch current and provides the switch with a connection to ground. A high-voltage probe, which measures

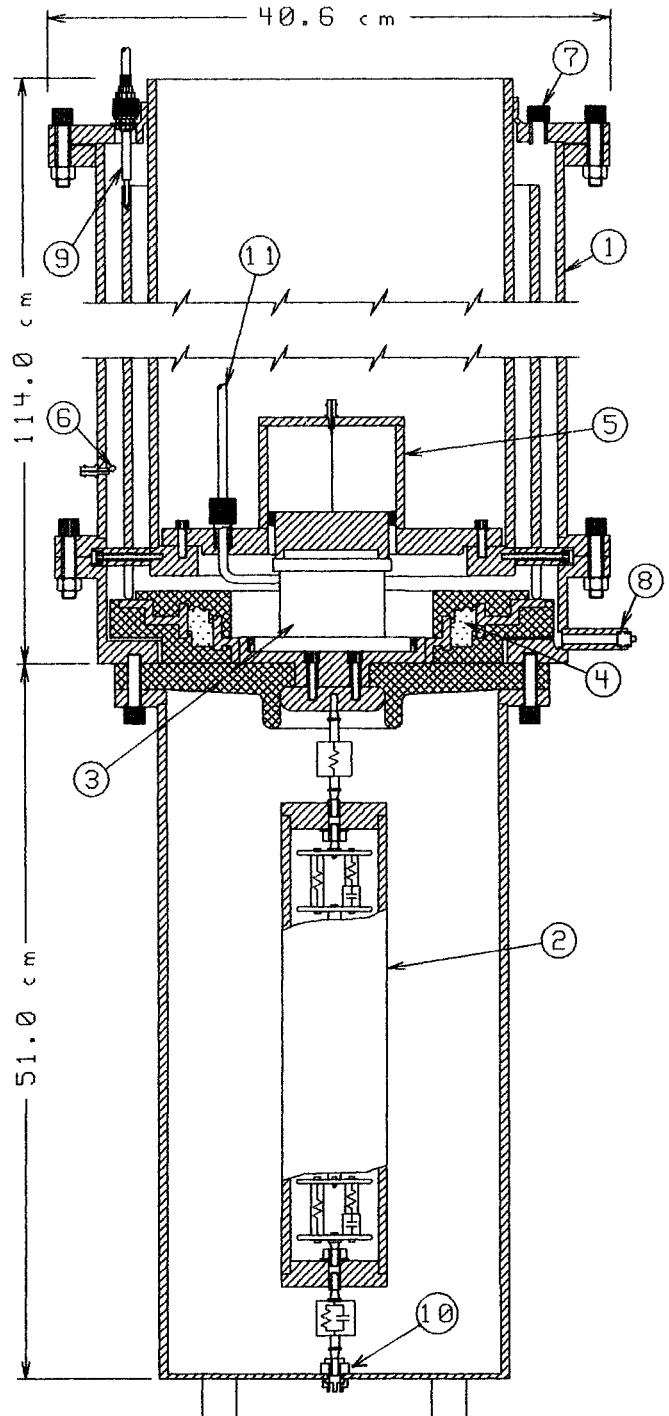

Fig. 1. Cross-section of the switch testing apparatus. The following is a list of the labeled parts: (1) PFL outer wall, (2) high-voltage section of voltage probe, (3) switch under test, (4) liquid load, (5) CVR, (6) B-dot loop, (7&8) fluid dielectric inlet and outlet (respectively), (9) high-voltage cable from charging circuit, (10) connector for voltage probe cable, and (11) gas line or electrical cable.

Report Documentation Page

Form Approved
OMB No. 0704-0188

Public reporting burden for the collection of information is estimated to average 1 hour per response, including the time for reviewing instructions, searching existing data sources, gathering and maintaining the data needed, and completing and reviewing the collection of information. Send comments regarding this burden estimate or any other aspect of this collection of information, including suggestions for reducing this burden, to Washington Headquarters Services, Directorate for Information Operations and Reports, 1215 Jefferson Davis Highway, Suite 1204, Arlington VA 22202-4302. Respondents should be aware that notwithstanding any other provision of law, no person shall be subject to a penalty for failing to comply with a collection of information if it does not display a currently valid OMB control number.

1. REPORT DATE JUN 1989	2. REPORT TYPE N/A	3. DATES COVERED -	
4. TITLE AND SUBTITLE A High-Power Fast-Response Switch-Testing System		5a. CONTRACT NUMBER	
		5b. GRANT NUMBER	
		5c. PROGRAM ELEMENT NUMBER	
6. AUTHOR(S)		5d. PROJECT NUMBER	
		5e. TASK NUMBER	
		5f. WORK UNIT NUMBER	
7. PERFORMING ORGANIZATION NAME(S) AND ADDRESS(ES) Naval Surface Warfare Center Dahlgren, VA 22448		8. PERFORMING ORGANIZATION REPORT NUMBER	
9. SPONSORING/MONITORING AGENCY NAME(S) AND ADDRESS(ES)		10. SPONSOR/MONITOR'S ACRONYM(S)	
		11. SPONSOR/MONITOR'S REPORT NUMBER(S)	
12. DISTRIBUTION/AVAILABILITY STATEMENT Approved for public release, distribution unlimited			
13. SUPPLEMENTARY NOTES See also ADM002371. 2013 IEEE Pulsed Power Conference, Digest of Technical Papers 1976-2013, and Abstracts of the 2013 IEEE International Conference on Plasma Science. Held in San Francisco, CA on 16-21 June 2013. U.S. Government or Federal Purpose Rights License.			
14. ABSTRACT A high-power, versatile switch-testing system, presently in operation at NSWCDahlgren, is described. The switch, along with a liquid-dielectric PFL, a liquid load, a voltage probe, and a current probe are mated in a low-inductance configuration. This arrangement allows the evaluation of switch performance on a nanosecond time scale.			
15. SUBJECT TERMS			
16. SECURITY CLASSIFICATION OF:			17. LIMITATION OF ABSTRACT
a. REPORT unclassified	b. ABSTRACT unclassified	c. THIS PAGE unclassified	SAR
			18. NUMBER OF PAGES 4
			19a. NAME OF RESPONSIBLE PERSON

the voltage drop across the switch and the CVR, consists of a high-voltage and a low-voltage sections that are separated by approximately 30 m of 50-ohm coaxial cable. The high-voltage section, which is attached to the high-potential terminal of the switch, is located below the switch, enclosed by a cylindrical, aluminum container that also provides the ground terminal for the probe. The low-voltage section is located at the input of an oscilloscope. A redundant switch-current measurement is performed by a B-dot loop probe located at the base of the PFL. The 6-mm diameter loop is attached to a chassis-feed-through BNC connector that screws into the PFL wall -- allowing the epoxy-coated loop to protrude 6 mm into the PFL's dielectric.

The PFL is resonantly charged, in approximately 3 us, through a triggered spark-gap switch when deionized water is used as the PFL dielectric, and when low rep-rates are acceptable (Figure 2a). For higher rep-rates, up to 10 kHz, a hard-tube command-charge circuit is used in conjunction with NSWC's 200-kW (50-kV, 4-A) average power test facility (Figure 2b). In this configuration, room-temperature ethylene-glycol/water mixtures are used to allow a slower (80-us) charging of the PFL, keeping the charge current within the ratings of the hard tube.

Conditioning of the liquid dielectrics in the PFL is performed by a continuously circulating system consisting of a pump and a deionizer. The fluid inlet and outlets are located at the top and bottom of the PFL, respectively, diametrically opposed.

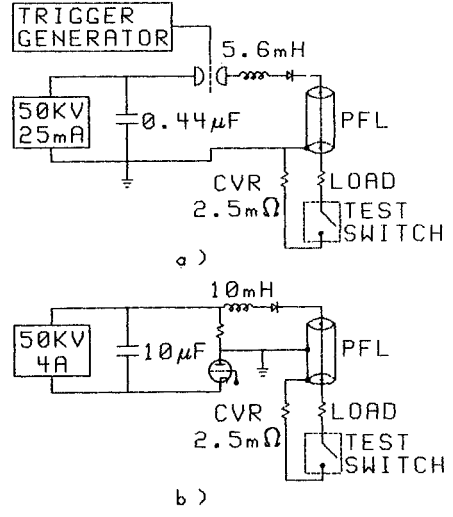

Figure 2. PFL charging circuits: (a) spark-gap resonant charge circuit, and (b) hard-tube command-charge circuit.

PFL Characteristics

The tubular, 1-m long PFL conductors have a wall thickness of 6.4 mm and are separated by 12.7 mm. These dimensions, together with water-glycol dielectrics over the range of mixture ratios, give the PFL the following characteristics: impedance = 0.29 - 0.34 ohms, capacitance = 101 - 73 nF, pulse width (matched case) = 59 - 50 ns, and a peak charge voltage of ~100 kV. The maximum operating voltage to date has been 65 kV. Table 1 outlines the PFL characteristics for different liquid dielectrics.

Table 1. PFL characteristics for different liquid dielectrics.

DIELECTRIC	ϵ_r (100 MHz)	C (nF)	Z_0 (Ω)	τ (ns)	MAX. OP. VOLTAGE
DISTILLED WATER	78	101	0.29	58.9	100KV
80% ETHEL. GLYCOL/ 40% WATER	56	73.0	0.34	50.0	100KV
ETHEL. GLYCOL	41	53.3	0.40	42.7	100KV
METHYL (ABS)	31	40.3	0.46	37.1	---
ETHEL (ABS)	23.7	30.8	0.53	32.5	---
TRANSFORMER OIL (TRANSIL)	2.2	2.9	1.72	9.9	~300KV
SILICONE OIL	2.8	3.6	1.53	11.2	~300KV

Load Characteristics

The load resistor consists of a resistive soap solution that is contained in a doughnut-shaped chamber formed by two concentric brass rings (1.9 cm apart) together with a polycarbonate insulating structure. The desired 1-ohm resistance was obtained by using a soap concentration of 28 grams of Arm-and-Hammer laundry detergent per liter of water, at 24 degrees-C. By maintaining this same temperature and varying the soap concentration a resistance range of 0.7 to 2.0 ohms can be obtained. Figure 3 shows the effects of soap-solution temperature on load resistance for two different soap concentrations. To raise the temperature of the solution 1 degree-C requires approximately thirty consecutive shots at a PFL charge voltage of 50 kV.

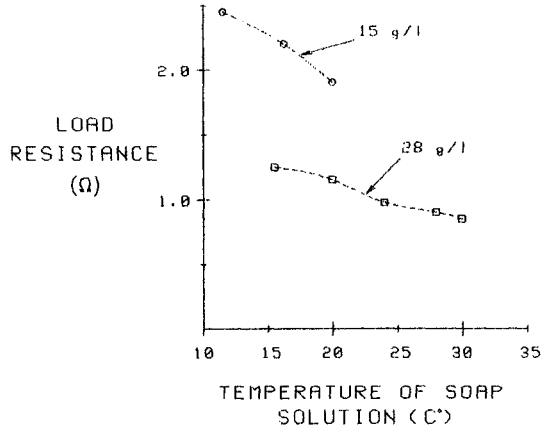

Figure 3. Effects of temperature on the soap solution resistor (load).

Diagnostics

The two measurements of interest in this system are the current through the switch, and the voltage drop across the switch. The switch current is measured mainly using a 2.5-milliohm CVR, manufactured by TM Research, that is rated at 50 kA (peak-current) and a 1-ns, risetime. Because the CVR is located directly above the switch, it is often convenient to remove it in order to physically access the top of the switch. For this reason, a back-up current measurement is provided by numerically integrating the output of a B-dot probe.

The switch and CVR voltage drop are measured using a wide-bandwidth (0 to 250 MHz) voltage-divider probe (with a 10,000 : 1

attenuation ratio) that has a D.C. voltage rating of 100 kV, and a short-pulse peak voltage rating of 150 kV. The CVR voltage is known from the current measurement and can be subtracted (when it is significant) from the probe voltage to obtain the switch voltage.

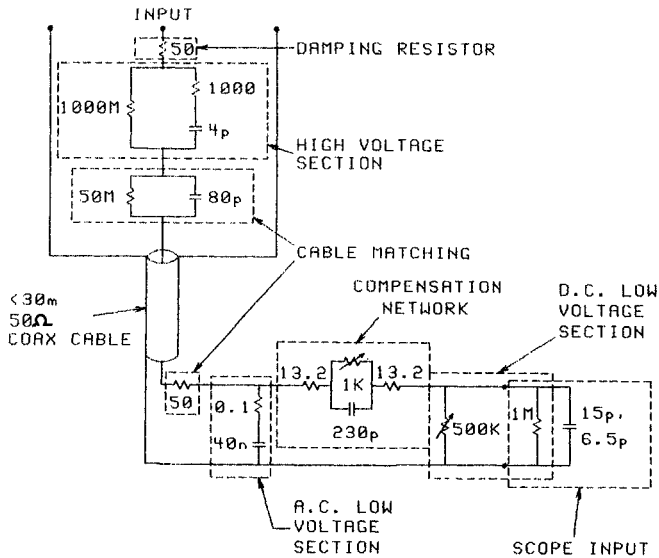

Figure 4. Circuit diagram of high-voltage probe.

The wide bandwidth and fast response requirements of the voltage measurement make the voltage probe the most complex of the diagnostics. The D.C. and the fast A.C. response of the probe are obtained by combining a resistive- and a capacitive-voltage-divider networks in parallel (Figure 4). The high- and low-voltage sections of the divider are separated by a low-loss 50-ohm cable that can be up to 30 m in length. The probe is designed to adapt to an oscilloscope or a transient digitizer that has an input impedance of $1\text{ M}\Omega$ and a frequency response of 250 MHz or better. A $500\text{-k}\Omega$ potentiometer in parallel with the $1\text{-M}\Omega$ impedance form the $\sim 100\text{-k}\Omega$ low-voltage section of the resistive divider. The potentiometer is used to balance the attenuation ratios between the resistive and capacitive dividers, providing a flat response over the frequency range of the probe. A compensation network is also included that attenuates overshoot distortions on the measured signal. For further details on the design of this unique probe see References 1 and 2.

The voltage and current signals are simultaneously recorded by either a dual-beam, 7000-series, Tektronix oscilloscope, or a Hewlett Packard 54111D, digitizing oscilloscope. Figure 5 shows a sample oscillograph of the measured voltage and current during the "turn-on" and "on" stages of the switch. These waveforms can be numerically manipulated to obtain power-time profiles as well as energy losses in the switch and load. The accuracy of these measurements were verified by performing an energy balance between the energy initially stored in the PFL and the energy dissipated in the load and switch. These numbers were consistently within 5% of each other. The rounding of the rise of the current pulse is mainly caused by the distributed, series inductance in the discharge loop of the PFL.

An estimate of this inductance can be obtained by duplicating the measured waveform through computer-aided circuit modeling. Through this same process the switch inductance can be estimated by assuming a switch circuit model and then duplicating the measured switch-voltage waveform by varying the element values.

The switch model used consisted of the following series-connected elements: an inductor, a battery, a resistor, and an ideal switch. Using this approach a system inductance (excluding the switch) of 15 nH was calculated. Figure 6 shows a sample of the switch voltage and current waveforms produced by the circuit model, which was simulated using the Microcap-II circuit analysis program.

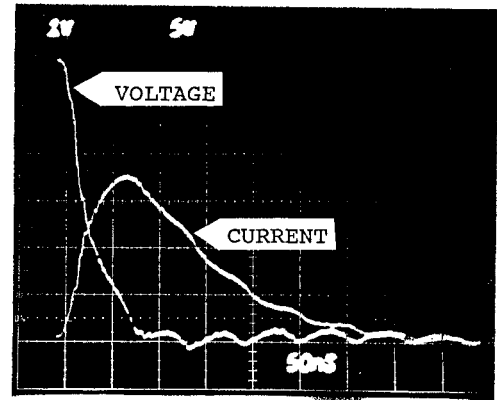

Figure 5. Switch voltage and switch current, simultaneously measured using the voltage probe and the CVR [V(peak) = 64 kV, I(peak) = 34 kA, timescale = 50 ns/div].

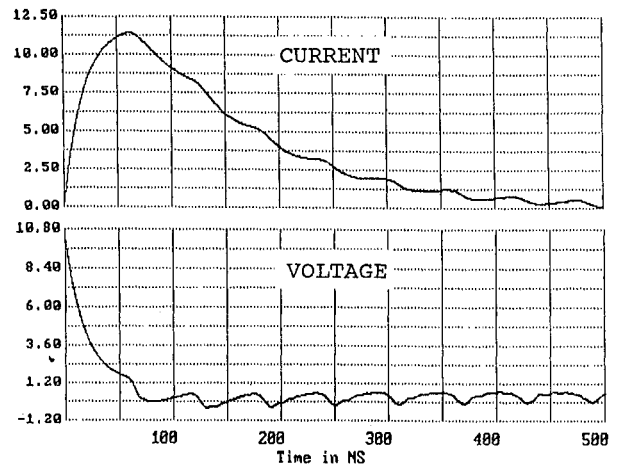

Figure 6. Switch voltage and current generated by a Microcap II simulation of the PFL discharge circuit.

Calibration

The B-dot probe and the voltage probe are the two diagnostics that require calibration. The B-dot probe was calibrated during normal system operation using the CVR as the standard. Figure 7 shows the simultaneously recorded B-dot and CVR output along with the integrated B-dot waveform. A HP-54111D was used to perform both the waveform recording and integrating functions.

Summary

This high-power, switch-testing system has been in operation since 1988, and has been used to test spark-gap switches and both electrically and optically triggered pseudo-spark switches. It has the ability to measure: (1) Switch voltages up to 100 kV (DC) and 150 kV (pulses), and (2) switch currents from 0 to >50 kA. Both of these diagnostics have a bandwidth that ranges from 0-250 MHz. To date, this system has operated in the following parameter ranges: PFL charge voltage = 10-64 kV, peak current = 1-34 kA, current risetime = 20-50 ns, pulse-width = 30-250 ns, and rep-rate operation up to 10-kHz (bursts of ten pulses). We have the capability to measure switch losses using the measured switch voltage and current, and through modeling we can calculate switch inductance.

Acknowledgements

The author wishes to thank: J. Power, W. Willis, and Dr. J. Sarjeant for providing a large part of the information and hardware used to reconstruct the switch-testing apparatus; Dr. R. McNight for the assistance in calibrating the voltage probe; and all the personnel from NSWC's Directed Energy Branch who assisted in this work, particularly S. Hairfield, Dr. R. Gripshover, T. Houghton, S. Griffiths, and K. Pillow. This work was funded by NSWC's Independent Exploratory Development Program.

References

- [1] J. Power, W. Nunnally, D. Young, "A 100-kV, 2-ns Risetime, DC-Coupled Probe," NBS Special Publication 628, Measurements of Electrical Quantities in Pulsed Power Systems, pp. 46-53, 1982.
- [2] J. Power, "Development of a 100 Kilovolt Two Nanosecond Risetime Probe with DC Response," M.S. Thesis, Texas Tech University, August 1986.

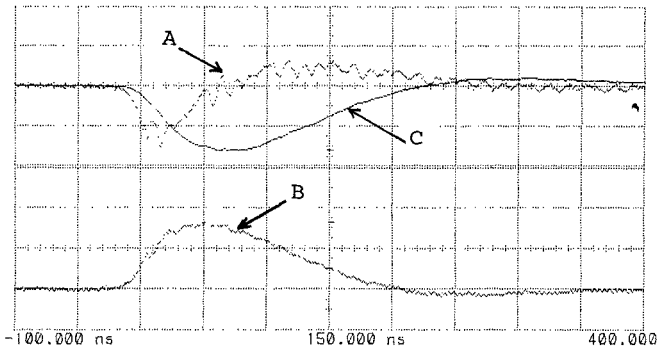

Figure 7. Simultaneously recorded waveforms from the B-dot probe (A) and from the CVR (B) shown along with the numerically integrated B-dot waveform (C).

The voltage probe was calibrated with the assistance of R. McNight, from NBS, using the set-up shown in Figure 8. A 200-ns, 1-kV square pulse (0.5-ns risetime), from a Spire (SPI-25) transmission-line pulser, is fed both to the probe, through a low inductance adaptor, and to a 1000:1 attenuator. The attenuator measures the input signal to the probe.

The probe adaptor consists of an aluminum plate that is bolted to the perimeter of the probe's outer body, and a feed-through connector that has its outer body attached to the center of the plate. The center lead of the connector makes a pressure contact with the high-voltage terminal of the probe. The compensation network shown in Figure 4 was used to remove pulse-overshoot distortions that occurred within the first 15 ns of the pulse. A 100-V, 10-ms square pulse (10-ns risetime), from an HP-214B pulse generator, is used to calibrate the balance between the attenuation ratios of the resistive- and capacitive-voltage dividers.

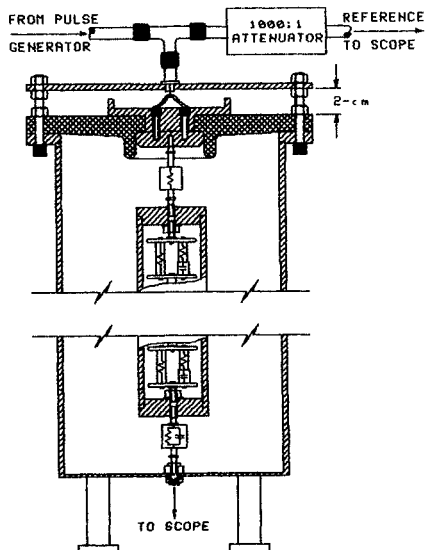

Figure 8. Set-up used to calibrate the voltage probe. Drawing shows the arrangement of the H. V. section of the voltage probe, the adaptor plate, and the attenuator.