

# PRELIMINARY INTERFEROMETRIC INVESTIGATIONS OF A DEMOUNTABLE IGNITRON

D.L. Loree, J.E. Burke, M. Giesselmann, and M. Kristiansen

Pulsed Power Laboratory  
 Department of Electrical Engineering  
 Texas Tech University  
 P.O. Box 4439  
 Lubbock, Texas 79409-4439

## Abstract

This paper describes preliminary Mach-Zehnder interferometry measurements done on a special demountable ignitron which has one set of throughports placed just below the bottom face of the anode. It is believed that this is the first set of interferometric diagnostics ever to be performed on a full size ignitron (15.24 cm diameter). Future knowledge of the discharge plasma charged particle density and other plasma behavior will help in the optimization of the ignitron for high peak power applications. The test system includes a 2.56 mF capacitor bank, a test stand of 1  $\mu$ H inductance, various voltage and current probes, a high speed rotating camera to record the fringe patterns, an Argon laser, and a Mach-Zehnder interferometer. The interferometer consists of a square chamber with a section cut out to insert the test stand, various mirrors and beam splitters with alignment motors, and a 2 watt argon laser as the light source. The demountable ignitron is operated as the crowbar switch in an underdamped system with the series switch being a commercial ignitron. The demountable ignitron was manufactured by National Electronics/Division of Richardson Electronics.

## Introduction

For more than a decade, there has been very little work done on improving ignitron switches. Recent work in trying to improve these switches for use in high peak power applications has resulted in internal and external modifications of the old commercial ignitron design. All internal components, other than the basic anode and mercury pool, have been removed. Anode and ignitor feedthroughs have been strengthened. There must still be more work done in order to improve certain features of this switch for future use in the pulsed power industry. In particular, the lifetime at high current and high Coulombs must be increased. Currently, research is being done in the areas of anode design, alternate triggering methods, and high current, high Coulomb failure analysis but very little work to date has been done in actually studying the conduction plasma and how it behaves. With this information, alterations in internal ignitron structure could possibly be designed and understood. With this in mind, a Mach-Zehnder interferometry system for the testing of a full sized ignitron has been established at Texas Tech University. The test ignitron, seen in Fig. 1, is denoted as the DIG (short for Demountable IGnitron) and has been used for a wide range of experiments in the past because of its adaptability.<sup>1,2</sup>

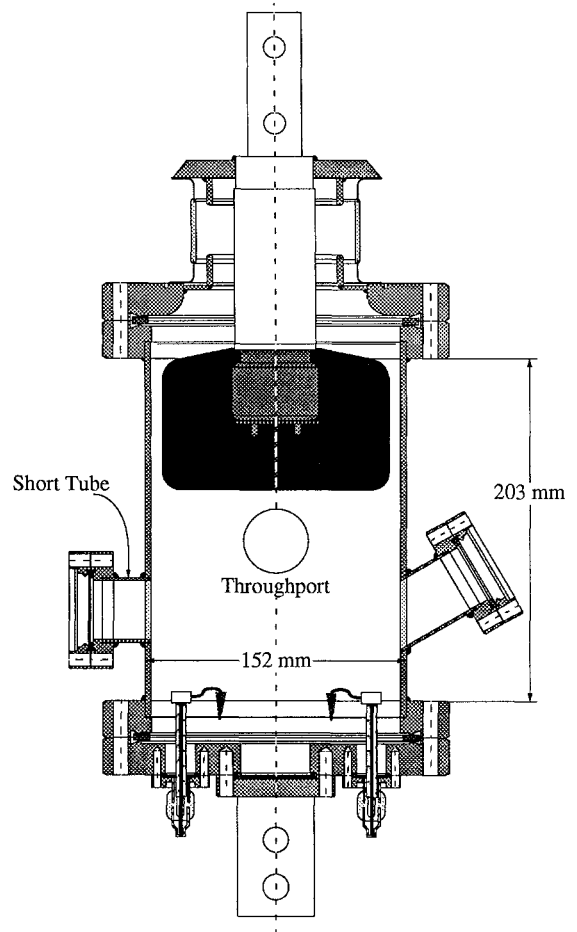

Fig. 1 Demountable Ignitron (DIG)

A Mach-Zehnder interferometer is a field visualization interferometer which detects photographically the phase shift in light (in this case a laser) introduced by a plasma. The phase shift introduced by the plasma is dependent upon the plasma charged particle density and the plasma dimensions. In the interferometry system, two light beams (a reference beam and a plasma beam) are derived from a common source. The plasma beam passes through the plasma while the reference beam does not, thus the phases of the two beams will now differ. The beams are then recombined with the phase differences creating an interference style fringe pattern. Furthermore, changes in the plasma density will cause shifting of the fringes, all of which can be photographed over time and analyzed.<sup>3</sup>

## Experimental Arrangement

The initial combination of components and alignment of the interferometry system involved much time and many people. A basic layout of the entire system can be seen in Fig. 2. As can be seen, the four capacitor banks feed into a test stand which houses the test

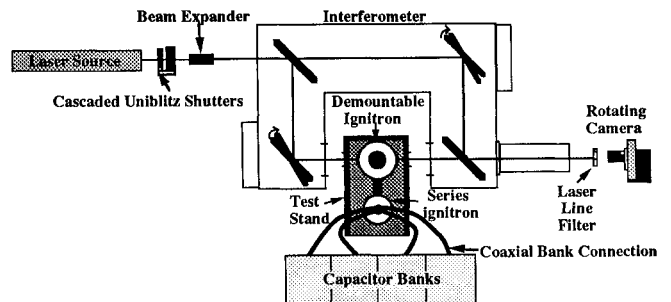

Fig. 2 Mach-Zehnder Interferometry System

# Report Documentation Page

Form Approved  
OMB No. 0704-0188

Public reporting burden for the collection of information is estimated to average 1 hour per response, including the time for reviewing instructions, searching existing data sources, gathering and maintaining the data needed, and completing and reviewing the collection of information. Send comments regarding this burden estimate or any other aspect of this collection of information, including suggestions for reducing this burden, to Washington Headquarters Services, Directorate for Information Operations and Reports, 1215 Jefferson Davis Highway, Suite 1204, Arlington VA 22202-4302. Respondents should be aware that notwithstanding any other provision of law, no person shall be subject to a penalty for failing to comply with a collection of information if it does not display a currently valid OMB control number.

1. REPORT DATE <b>JUN 1989</b>		2. REPORT TYPE <b>N/A</b>		3. DATES COVERED <b>-</b>	
4. TITLE AND SUBTITLE <b>Preliminary Interferometric Investigations Of A Demount Able Ignitron</b>				5a. CONTRACT NUMBER	
				5b. GRANT NUMBER	
				5c. PROGRAM ELEMENT NUMBER	
6. AUTHOR(S)				5d. PROJECT NUMBER	
				5e. TASK NUMBER	
				5f. WORK UNIT NUMBER	
7. PERFORMING ORGANIZATION NAME(S) AND ADDRESS(ES) <b>Pulsed Power Laboratory Department of Electrical Engineering Texas Tech University P.O. Box 4439 Lubbock, Texas 79409-4439</b>				8. PERFORMING ORGANIZATION REPORT NUMBER	
9. SPONSORING/MONITORING AGENCY NAME(S) AND ADDRESS(ES)				10. SPONSOR/MONITOR'S ACRONYM(S)	
				11. SPONSOR/MONITOR'S REPORT NUMBER(S)	
12. DISTRIBUTION/AVAILABILITY STATEMENT <b>Approved for public release, distribution unlimited</b>					
13. SUPPLEMENTARY NOTES <b>See also ADM002371. 2013 IEEE Pulsed Power Conference, Digest of Technical Papers 1976-2013, and Abstracts of the 2013 IEEE International Conference on Plasma Science. Held in San Francisco, CA on 16-21 June 2013. U.S. Government or Federal Purpose Rights License.</b>					
14. ABSTRACT <b>This paper describes preliminary Mach-Zehnder interferometry measurements done on a special demountable ignitron which has one set of through ports placed just below the bottom face of the anode. It is believed that this is the first set of interferometric diagnostics ever to be performed on a full size ignitron (15.24 em diameter). Future knowledge of the discharge plasma charged particle density and other plasma behavior will help in the optimization of the ignitron for high peak power applications. The test system includes a 2.56 mF capacitor bank, a test stand of 1 11H inductance, various voltage and current probes, a high speed rotating camera to record the fringe patterns, an Argon laser, and a Mach-Zehnder interferometer. The interferometer consists of a square chamber with a section cut out to insert the test stand, various mirrors and beam splitters with alignment motors, and a 2 watt argon laser as the light source.</b>					
15. SUBJECT TERMS					
16. SECURITY CLASSIFICATION OF:			17. LIMITATION OF ABSTRACT <b>SAR</b>	18. NUMBER OF PAGES <b>3</b>	19a. NAME OF RESPONSIBLE PERSON
a. REPORT <b>unclassified</b>	b. ABSTRACT <b>unclassified</b>	c. THIS PAGE <b>unclassified</b>			

ignitron and a commercial ignitron. The stand is inset into the cutout section of the interferometer housing so that the throughports of the DIG are aligned with the laser beam. The argon laser provides a continuous beam, which was helpful during the alignment procedure. For testing, the beam is pulsed through the system with a normally-open, normally-closed cascaded shutter combination. A timing diagram for the shutters can be seen in Fig. 3. This combination, when triggered simultaneously, provided about a 400  $\mu$ s laser pulse to the interferometry system. The triggering of the shutters is timed so that the laser pulse occurs during the conduction period of the crowbar ignitron (i.e. the DIG). The Dynafax rotating camera was run in an open shutter mode at full speed which then provided 3  $\mu$ s exposures with about 45  $\mu$ s between exposures. There were times when the laser line filter was removed from the optical path. This allowed both the fringes and the discharge light to be photographed, thus allowing us to check the laser window timing.

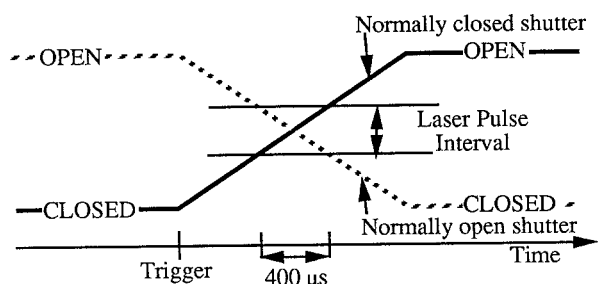

Fig. 3 Shutter Timing Diagram

### Experimental Results

The system described in the previous section was assembled, aligned, and tested. For the preliminary test runs discussed in this paper, the DIG utilized a normal, graphite anode. In the future, alternate anode materials and geometries will be investigated. Figure 4 shows a plot of voltage and current for a typical, well timed crowbar shot. Figure 5 shows a sequence of exposures from a single test shot. For this particular shot, the laser line filter was removed to verify proper timing. Therefore, the fringe patterns on certain exposures were clouded by light from the discharge. For this reason, certain frames of this sequence were exposed for longer periods of time when developing the photographic prints. A note to make here is the obvious diamond shape of the exposures. When attempting to focus the fringe patterns on the drum of the rotating camera, it became necessary to insert an external extension to the lens

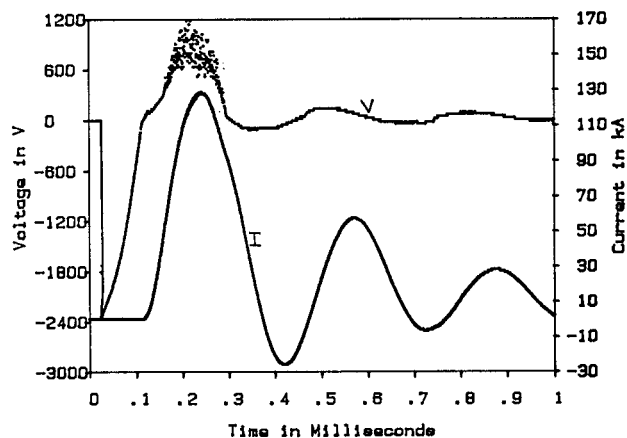

Fig. 4 Typical Voltage and Current Plot (Graphite Anode,  $I_p=128$  kA)

of the camera. Consequently the interferometric beams are routed through the camera optics in such a way, that the diamond shaped exit pupil defines the beam shape and is projected in sharp outline onto the film. This diamond pattern created the stable reference outline that facilitates the detecting of any fringe shifts. Fig. 5 shows a set of relatively coarse fringes. By adjusting the focusing control of the lens, smaller and more dense fringe patterns can be obtained as necessary. Figure 6 was obtained by scanning the exposures of Fig. 5 and adding reference lines to show the fringe shift caused by the change in conduction current in the test ignitron. The most evident shifting is in frames 2 and 3 both of which occur around the time of peak current conduction. The jitter of the cascaded shutters caused some shots where the laser pulse occurred before or after the crowbar conduction period. Many of these shots were closely looked at in order to make sure that system vibrations during conduction could not cause fringe shifts similar to Figs. 5 or 6. We could not detect any fringe shifting in the shots which were not timed properly, thus vibrations are not a factor in the shifting of the interferometric patterns.

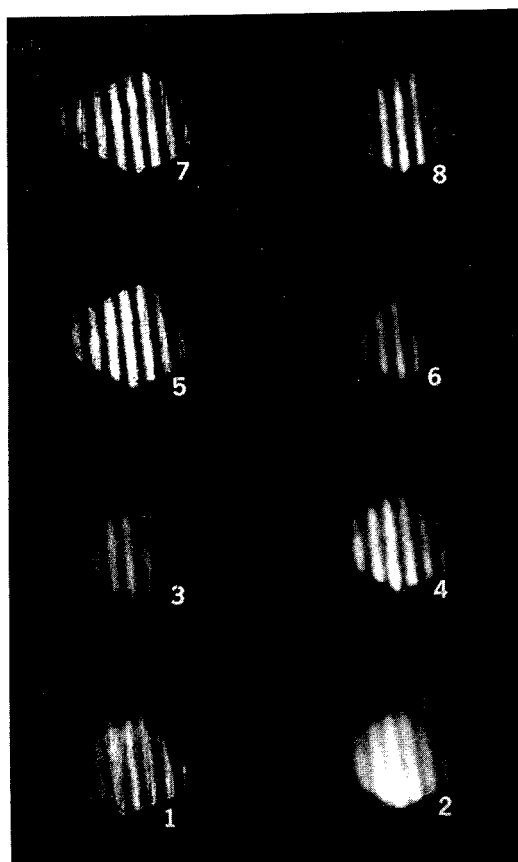

Fig. 5 Course Fringe Patterns ( $V_B = 5$  kV)

### Summary

The goal of this paper was to describe the assembly and initial test runs of a Mach-Zehnder interferometry system utilizing a full size ignitron as the plasma chamber. Assembly and alignment was accomplished after much effort and time. Modifications to the mechanical camera provided a diamond shaped reference pattern for detection of fringe shift. The continuous Argon laser was pulsed at the correct time by a cascaded shutter combination which was in turn triggered before the conduction period by a delay generator. Future

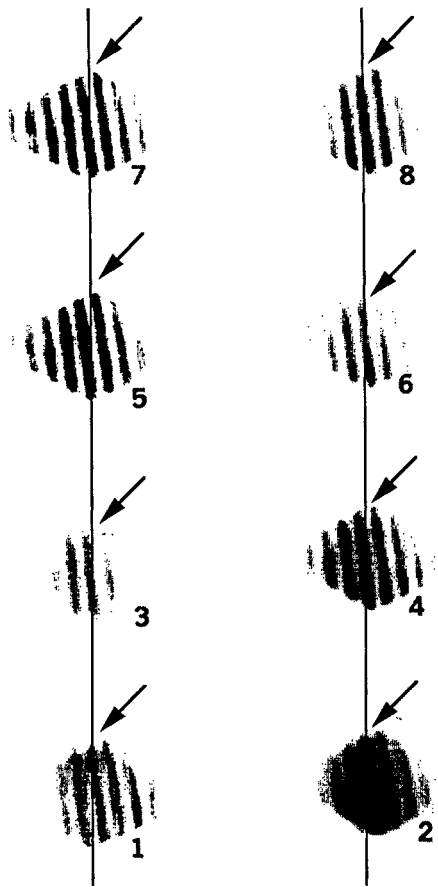

Fig. 6 Scanned Fringe Patterns  
with Reference Line  
( $V_B = 5 \text{ kV}$ )

work will deal with altering the anode geometry and material in the test ignitron. In particular, a stainless steel cup anode and a stainless steel slit-cup anode will be tested. It is hoped that these anodes will provide some waviness or bending of the interferometric fringes. This will indicate plasma motion and possible rotation. The amount of shifting can, with some assumptions, be related to the plasma index of refraction and ultimately to some approximation of the plasma density.

#### Acknowledgements

We would like to thank Lawrence Livermore National Laboratory and the Texas Tech Center for Energy Research for their funding of our past and present research. We also owe a great debt to Anton "Tony" Shulski at Richardson Electronics for his manufacturing of the DIG and his constant contact and help. Furthermore, we thank the following people at the Texas Tech University Pulsed Power Laboratory: Lonnie Stephenson, Robert Smith, Gene Igel, Ellis Loree, and Kevin Kelly.

#### References

- [1] D.L. Adkins-Loree, M. Giesselmann, and M. Kristiansen, "Axial Magnetic Field Effects on Redesigned Ignitrons Utilizing Glass Walls and Cylindrical Dielectric Inserts," Conference Record of the 18th Power Modulator Symposium, pp. 241-246, June 1988.
- [2] J.E. Burke, D.L. Loree, M. Giesselmann, and M. Kristiansen, "Optical Study of the Effects of Anode Geometry of the Performance of an Ignitron," presented at the Seventh Pulsed Power Conference, Monterey, California, June 12-14, 1989.
- [3] J. Thompson and M. Kristiansen, Plasma Diagnostic Seminar, 2nd Ed., Texas Tech University, Lubbock, Tx., pp.105-132, June 1976.