

FIVE-MEGAJOULE HOMOPOLAR UPGRADE

T. M. Bullion, R. C. Zowarka, T. A. Aanstoos,
W. F. Weldon, H. G. Rylander, and H. H. Woodson,
The University of Texas at Austin
Taylor Hall 167
Austin, Texas 78712

Summary

The five-megajoule homopolar generator (5-MJ HPG) designed and built in 1974 by the Center for Electro-mechanics at the University of Texas at Austin (CEM-UT) was the result of an engineering feasibility study that examined alternate means of pulsed energy storage for controlled thermonuclear fusion experiments. The machine proved very reliable and useful in a variety of applications, notably pulsed resistance welding, and was modified in 1978 to improve its flexibility and ease of maintenance. CEM-UT is now completing a major upgrading of this HPG to a hydraulically motored, 10-MJ, 47-V, 1.02-MA device capable of welding large-section, high-carbon railroad rail. This report considers the design and fabrication of the new rotor, shaft, brush mechanisms, field coil, making switch, busbar system, and control system, as well as the addition of the 31-MPa (4,500 psi) hydraulic motoring system. Future applications of the 10-MJ HPG are also discussed.

Introduction

The 5-MJ HPG was built in 1974 by CEM-UT to demonstrate the feasibility of inertial energy storage using homopolar conversion. The machine was originally intended to be a proof-of-principle experiment with a design current rating of 165 kA, but because of its low internal impedance, the 5-MJ HPG produced 560 kA when discharged from half speed into a short circuit.¹ After early testing of the HPG proved its reliability, its function changed from that of an energy storage experiment to that of a pulsed power supply for a wide variety of experiments. This required modifications to the generator to allow more efficient, easier operation, notably, improvements to the bearings, busbars, and making switch.² Since this first rebuild, the 5-MJ HPG has been used largely as a pulse resistance welding power supply.³ Hundreds of discharges have been made in this mode, many at current levels in excess of 300 kA. Because an upcoming resistance welding program on high-carbon railroad rail of large cross-sectional area (up to 90 cm²) would require discharges at current levels above the capability of the 5-MJ HPG, a decision was made to upgrade the machine to approximately 10-MJ stored energy. To allow this increase in stored energy and the correspondent increase in machine current, several components of the old 5-MJ HPG had to be upgraded or replaced. Among these were the rotor and shaft, field coil, shaft and rotor brush mechanisms, internal conductors, and busbars. Higher current levels made it necessary to upgrade the original making switch and it was decided to build a duplicate switch to be used in parallel with the old one. To simplify machine operation and to insure the documentation of important parameters, a new system of controls and instrumentation was designed and built. Also, a 31-MPa (4,500 psi) external hydraulic motoring supply was chosen to replace the electrical self-motoring mode used on the 5-MJ, to reduce heat input to the system.

With these improvements, the rebuilt HPG will store 10-MJ at approximately 5,350 revolutions per minute and will be rated 1.02 MA, 47 V.

Design and Construction of Upgraded Components

The various components of the 10-MJ HPG are shown in Figure 1. All parts (with the exception of the unchanged 5-MJ HPG magnetic yoke) were fabricated in the CEM-UT laboratory or in the University of Texas Mechanical Engineering Machine Shop. The following sections discuss the changes and additions made to the original 5-MJ HPG in this upgrade.

Rotor and Shaft

A 0.75-m diameter, 0.28-m thick AISI 4340 aircraft quality steel rotor is shrunk on to a 0.14-m diameter beryllium copper shaft (Fig. 2). This new rotor is the same grade as the 0.61-m diameter one used on the original 5-MJ HPG, but can store about twice the energy at similar rotational speeds.

The movement of inertia of the new rotor with a mass of 925.43 kilograms is

$$I = 1/2 mr^2 = 65.07 \text{ kg} \cdot \text{m}^2$$

The design speed of 560 rad/s is dictated by the surface speed of the periphery of the rotor where electrical brushes must run (extensive testing has shown that a reasonable surface speed for these brushes is 200 to 220 m/sec)⁴. At this rotational speed, the stored energy is

$$KE = 1/2 I\omega^2 = 10.20 \times 10^6 \text{ J.}$$

The 304 stainless steel shaft used on the original 5-MJ configuration represented the single largest part of the machine's internal resistance. Since this internal resistance must be held to an absolute minimum for maximum current output, a beryllium copper shaft was chosen to replace the old one. Beryllium copper is a copper alloy with relatively high strength and an electrical resistivity that is one fifteenth that of stainless steel.

A shrink fit of 0.0017 m/m was used between the steel rotor and beryllium copper shaft to result in an interface pressure of $2.58 \times 10^7 \text{ Nt/m}^2$ when operating at the design speed of 560 rad/s. This demonstrates that the maximum operating speed is well below the limiting speed (the speed at which the shrink fit is overcome by rotational strain). At standstill, this pressure becomes $1.34 \times 10^8 \text{ Nt/m}^2$.

During the first rebuild of the 5-MJ HPG, new orifice compensated hydrostatic bearings were built to solve several problems encountered on earlier bearing systems. These bearings exhibit very low losses and full stiffness at zero speed, two essential characteristics for homopolar machines. These bearings were found to be in excellent condition upon disassembly and were unmodified in this upgrade. Resistive temperature devices (RTDs) were installed near the bearing lands to monitor temperature rise during motoring. AISI 4140 steel sleeves were shrunk onto the beryllium copper shaft of the new rotor for these hydrostatic bearings to run on. This was necessary to provide a hard, smooth surface and to prevent intimate contact between the beryllium copper shaft and bronze bearing lands (intimate contact between similar metals is undesirable in sliding surfaces).

The rotor outer diameter and bearing journals

Report Documentation Page

Form Approved
OMB No. 0704-0188

Public reporting burden for the collection of information is estimated to average 1 hour per response, including the time for reviewing instructions, searching existing data sources, gathering and maintaining the data needed, and completing and reviewing the collection of information. Send comments regarding this burden estimate or any other aspect of this collection of information, including suggestions for reducing this burden, to Washington Headquarters Services, Directorate for Information Operations and Reports, 1215 Jefferson Davis Highway, Suite 1204, Arlington VA 22202-4302. Respondents should be aware that notwithstanding any other provision of law, no person shall be subject to a penalty for failing to comply with a collection of information if it does not display a currently valid OMB control number.

1. REPORT DATE JUN 1981	2. REPORT TYPE N/A	3. DATES COVERED -			
4. TITLE AND SUBTITLE Five-Megajoule Homopolar Upgrade		5a. CONTRACT NUMBER			
		5b. GRANT NUMBER			
		5c. PROGRAM ELEMENT NUMBER			
6. AUTHOR(S)		5d. PROJECT NUMBER			
		5e. TASK NUMBER			
		5f. WORK UNIT NUMBER			
7. PERFORMING ORGANIZATION NAME(S) AND ADDRESS(ES) The University of Texas at Austin Taylor Hall 167 Austin, Texas 78712		8. PERFORMING ORGANIZATION REPORT NUMBER			
9. SPONSORING/MONITORING AGENCY NAME(S) AND ADDRESS(ES)		10. SPONSOR/MONITOR'S ACRONYM(S)			
		11. SPONSOR/MONITOR'S REPORT NUMBER(S)			
12. DISTRIBUTION/AVAILABILITY STATEMENT Approved for public release, distribution unlimited					
13. SUPPLEMENTARY NOTES See also ADM002371. 2013 IEEE Pulsed Power Conference, Digest of Technical Papers 1976-2013, and Abstracts of the 2013 IEEE International Conference on Plasma Science. Held in San Francisco, CA on 16-21 June 2013. U.S. Government or Federal Purpose Rights License.					
14. ABSTRACT					
15. SUBJECT TERMS					
16. SECURITY CLASSIFICATION OF:			17. LIMITATION OF ABSTRACT SAR	18. NUMBER OF PAGES 4	19a. NAME OF RESPONSIBLE PERSON
a. REPORT unclassified	b. ABSTRACT unclassified	c. THIS PAGE unclassified			

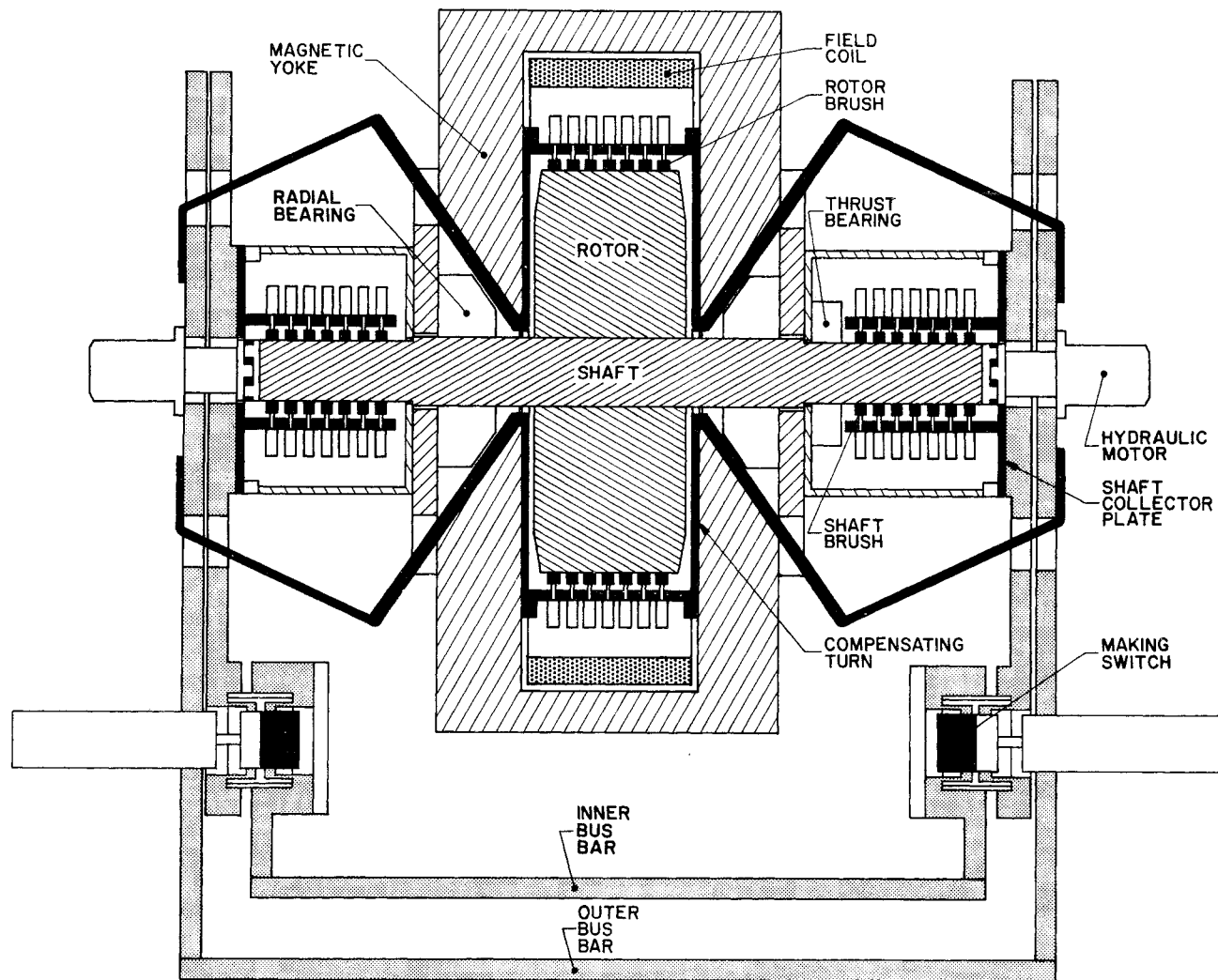

Fig. 1. 10-MJ HPG Configuration

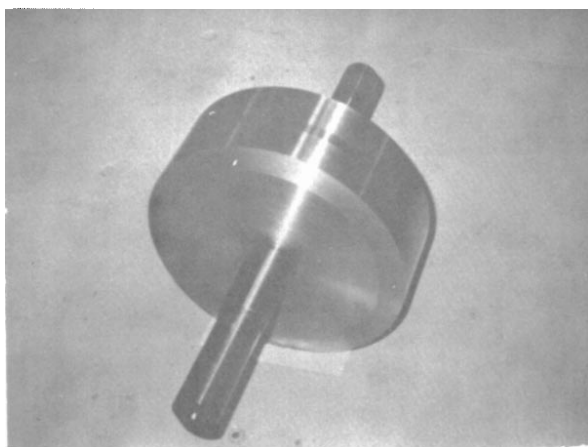

Fig. 2. 10-MJ HPG Rotor

were ground between centers to insure concentricity. Finally the rotor was dynamically balanced to under 6 g/cm to reduce vibration.

Brush Mechanisms

The 5-MJ HPG used solid brushes made of a sintered copper-graphite material (Morganite CM-1S) because of its low sliding contact voltage drop, friction and wear characteristics. These 2.54 cm square

by 1.0 cm thick brushes were silver brazed to 1.6 mm thick copper straps that acted as electrical conductors and mechanical brush locating members. The brushes were forced down onto the rotor or shaft with coil springs and lifted with pneumatic cylinders. While the shaft brushes were able to use standard commercial air cylinders, due to space limitations the rotor brush cylinders had to be specifically made. The rotor brush mechanism consisted of 6 tracks around the circumference of the rotor with 18 brushes per track resulting in a maximum current density of 800 A/cm² at 560 kA. Each shaft brush mechanism consisted of 6 tracks of 6 brushes each for a maximum current density of 1200 A/cm². These brush mechanisms performed well and upon disassembly after several hundred discharges little wear or damage was observed.

Because of the success of these brush mechanisms, it was decided to use the same basic configuration with some improvements for the 10-MJ HPG. Because of the extensive initial testing and observed performance of the copper-graphite material, it was again chosen for the new machine. A greater number of smaller (1.27 cm x 1.91 cm) brushes were silver brazed to 2.4 mm thick ETP 110 copper straps. One commercial 1.91 cm bore stainless steel pneumatic cylinder activates each pair of brushes by pushing on a hard anodized aluminum foot (Fig. 3). Brush down force is adjusted by regulating cylinder pressure. The new rotor brush mechanism consists of 40 rows (across the

rotor face) of 14 brushes each, activated by 7 pneumatic cylinders (Fig. 4). For a maximum machine current of 1.02 MA, the current density is 750 A/cm². Each shaft brush mechanism consists of 10 rows of 14 brushes each corresponding to a current density of 1500 A/cm² (Fig. 5). Since air is supplied to the rotor and shaft brush mechanisms by separate manifolds, the down force on the two sets of brushes need not be the same.

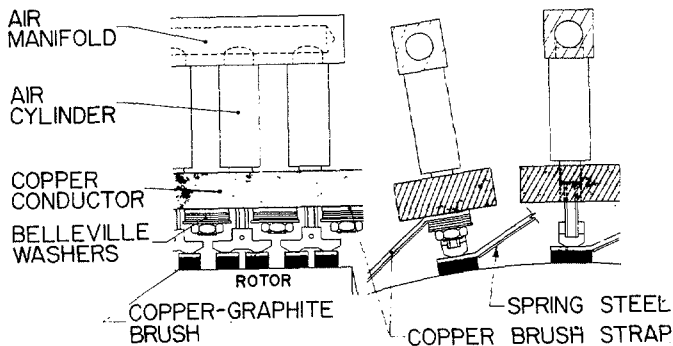

Fig. 3. 10-MJ HPG Brush Mechanism Schematic

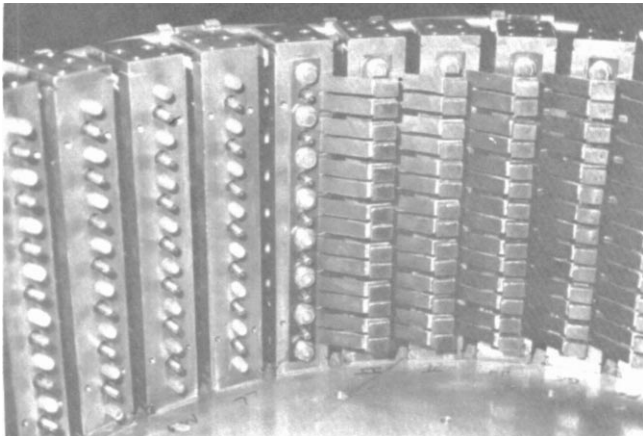

Fig. 4. Rotor Brush Mechanism

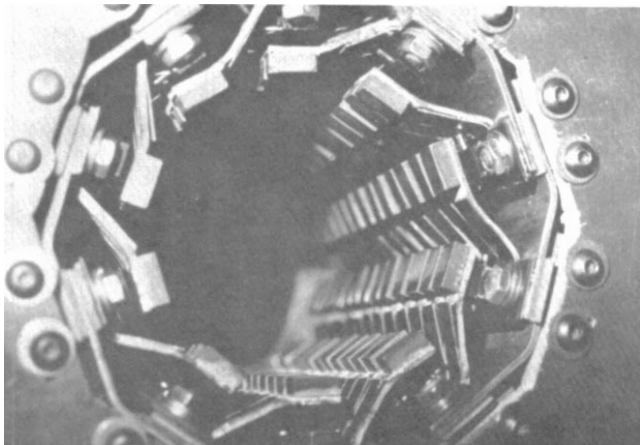

Fig. 5. Single Shaft Brush Mechanism

The internal conductors, which were aluminum on the 5-MJ HPG, were remade out of ETP 110 copper on this rebuild to lower the machine's internal resistance. All bolted connections were prepared carefully and made up using Belleville washers to assure low resistance joints.

Field Coil

The 260 turn field coil used on the 5-MJ HPG was made up of ten individual, water-cooled pancake coils and provided 71,500 Amp-turns at an excitation of 275A. This corresponds to a magnetic field flux density of 1.6 T. Each pancake consisted of 13 turns in and 13 turns out and was wound with soft copper tubing, insulated with a braided fiberglass sleeve and potted in epoxy.

To provide room for the new, larger rotor and the new rotor brush mechanism, the field coil had to be much thinner radially. The coil was constructed from 12.0-mm square copper tubing with a 7.0-mm diameter cooling passage. This stock came very close to the optional geometry established by considering the trade-off between coolant flow area and copper conductor area. A general algorithm relating the water cooling rate to the I²R heating rate was expressed in terms of the number of turns per coil, number of coils, and the 71,500 A-t design goal. The boundary conditions on the design were 3000-A maximum excitation and 0.34 MPa (50 psi), 25°C cooling water. The result was an 11-pancake coil with 4 turns in and 4 turns out. The 71,500 A-t design goal could be achieved with an 812 A excitation and the 26,000 A-t magneto motive force needed for rail welding would require only 295 A excitation.

The square copper tubing was half lap wrapped with epoxy impregnated tape, wound around a wooden mandrel, and cured with steam for approximately 5 hours at 130°C. A 0.75-mm thick Nomex sheet was used to insulate between layers with coils and between individual coils. After curing each pancake, the coil was assembled, again wrapped with the epoxy impregnated tape and cured to produce a solid unit.

This coil is about 150 mm thinner radially than the old one and, therefore, leaves room for the larger rotor and new brush mechanism.

Switching and Busbars

The 10-MJ HPG is a two-sided machine electrically, with current collected from both sides of the shaft to minimize shaft brush current density and rotor side loading. A second, fast-acting, air-activated making switch, identical to the previous 5-MJ HPG switch⁵, was constructed and the two installed in line with the shaft bus arms. Aluminum busbars, with both bolted and welded electrical joints, complete the electric circuit.

The switches were designed and adjusted to make initial contact with a velocity high enough (about 5 m/s) to prevent contact arcing, and to close both sides of the circuit in a time short compared to the rise time of discharge current, which is about 50 ms. As tested, both close about 10 ms after the initial firing signal, and within about 2 ms of each other, which is acceptable. However, the high net axial electromagnetic forces resulting from an accidental one-sided discharge (if one switch fails to close) would exceed the load-carrying capacity of the hydrostatic thrust bearing and cause serious machine damage. The system protects against this danger in the following ways:

1. The two solenoids were wired in series,
2. The automatic control system verifies both solenoid coils are intact (i.e., not shorted) before enabling the discharge sequence, and
3. Pneumatic "pushers" act in line with each solenoid's plug to automatically trigger both switches whenever either switch closes.

The aluminum busbars are made from rolled 6061 aluminum plate, 3.81 cm thick and 45.72 cm wide. The busbars are tightly routed and compensated to reduce total resistance and inductance. Electromagnetic repulsive forces during discharge can approach 146,000 N/m; these forces are contained either by insulated Grade 5 through-bolts or insulated wrap-around clamps made from rectangular steel tubing. The entire busbar system weighs about 550 kg and is supported by six insulated steel stands with shock absorbing leveling pads. The riser tabs that form this 10-MJ HPG output terminals are sized and located to accommodate a wide number of experiments.

Hydraulic Motoring System

A hydraulic motoring system was chosen to spin the rotor of the 10-MJ HPG to the design speed of 560 rad/s (5350 rpm). In the old configuration, a large dc power supply was used to self-motor the HPG. Using this method, some of the electrical brushes were down throughout the entire time of motoring, thus adding appreciable heat to the rotor and brushes. For use as a laboratory power supply, it is desirable to minimize the time between shots of the HPG; one important factor in determining this time is the temperature of the various components. External motoring with hydraulics is therefore advantageous because the brushes do not have to be down during motoring.

Two piston-type hydraulic motors, one attached through a flexible coupling to each end of the shaft, are capable of motoring the 10-MJ rotor to 5400 rpm in under six minutes. At this speed, these motors deliver about 53.0 kw (71.1 horsepower) each at a supply pressure of 31.03 MPa (4500 psi). Oil is supplied at this pressure with a flowrate of 189.25 liters per minute (50 gallons per minute) by a hydraulic power unit that consists of a 112 kW (150 hp) motor, variable displacement pump, and appropriate valving and accessories. When the desired rotor speed is reached, a solenoid operated bypass valve is fully opened allowing the hydraulic motors to freewheel for discharge or coast down.

Controls and Instrumentation

Due to the change in duty of the HPG from experiment to power supply, it was decided to build a new, automatic control system. Control sequence and interlocks are programmed in an ATC LDC-40 ladder logic controller. Data acquisition is performed with an 18-channel light beam oscillograph capable of reproducing a 5-kHz square wave. Parameters recorded on this oscillograph are generator current and voltage, voltage across the load, axial field strength in the machine's air gap, thrust bearing pressure, generator speed, and field current. Bearing temperature and pressure are also monitored.

Predicted Performance

The internal resistance of the 10-MJ HPG including busbars, switches, and all bolted joints is predicted to be 15 $\mu\Omega$. The equivalent capacitance of the generator is

$$C = \frac{4\pi^2 I}{\phi^2}$$

where I = rotor moment of inertia and ϕ = magnetic flux. At full field excitation, the magnetic flux is 0.547 wb resulting in a minimum machine capacitance of 8,450 F. Since the geometry of the machine and busbar system has not significantly changed the area enclosed by the transport current path, it is assumed that the inductance of the 10-MJ HPG will be equal to the measured value of inductance of the 5-MJ HPG or

about 1 μH . These R, L, and C values predict an underdamped discharge response. With a 7 $\mu\Omega$ load, this response becomes overdamped with a discharge current that rises to 1.02 MA in 85 ms.

Conclusion

Initial testing of the 10-MJ HPG has recently begun. The machine has been motored in a series of steps to approximately 3,800 rpm, during which time brushes were lowered onto the rotor and shaft to help them contour to the moving surfaces. Open circuit voltage tests were then conducted to measure magnetic field and field time constant, and to test the control sequence. Several low speed, short circuit discharge tests have been performed with solid railroad rail. A discharge at 1,650 rpm, 1.25-T (reduced field), and 12.5-V open circuit voltage produced 250 kA through the rail. Measured voltage and current on this and other tests lead to an actual internal machine resistance of 20.5 $\mu\Omega$.

After preliminary testing is completed, the 10-MJ HPG will be connected to a wide variety of experiments. In addition to the rail welding program already begun, other industrial welding programs are planned including spot, seam, and projection welding. Also, a paper study now in progress on homopolar billet heating could lead to an experimental project. In the next few months, the 10-MJ HPG will also be used to power a railgun electromagnetic propulsion experiment.

Acknowledgments

This work was performed under National Science Foundation Grant ISP-8005918. Additional funding was provided by the Texas Atomic Energy Research Foundation. The initial work on the 5-MJ HPG was funded by the U.S. Department of Energy.

References

1. W. F. Weldon, M. D. Driga, H. H. Woodson, H. G. Rylander, "The Design, Fabrication, and Testing of a Five Megajoule Homopolar Motor-Generator," Proc. Intern. Conf. on Energy Storage, Compression, and Switching, Torino, Italy, November 5-7, 1974.
2. J. H. Gully, K. M. Tolk, R. C. Zowarka, M. Brennan, W. L. Bird, W. F. Weldon, H. G. Rylander, and H. H. Woodson, "Rebuilding the Five Megajoule Homopolar Machine at the University of Texas," 2nd IEEE International Pulsed Power Conference, Lubbock, TX, June 12-14, 1979.
3. G. B. Grant, W. M. Featherston, R. E. Keith, W. F. Weldon, H. G. Rylander, and H. H. Woodson, "Homopolar Pulse Resistance Welding, A New Welding Process," American Welding Society, 60th Annual Meeting, Detroit, MI, April 2-6, 1979.
4. Michael Brennan, "The Experimental Investigation of the Effects of Contact Area and Large Currents on Sliding Electrical Contacts," master's thesis, the University of Texas at Austin, May 1979.
5. Paul Wildi, "High Current Making Switch," Sixth Symposium on Engineering Problems in Fusion Research, San Diego, CA, November 18-21, 1975.