

BY ORDER OF THE COMMANDER

SMC Standard SMC-S-008

13 June 2008



Supersedes:
New issue

Air Force Space Command

**SPACE AND MISSILE SYSTEMS CENTER
STANDARD**

**ELECTROMAGNETIC
COMPATABILITY
REQUIREMENTS FOR
SPACE EQUIPMENT
AND SYSTEMS**

APPROVED FOR PUBLIC RELEASE; DISTRIBUTION IS UNLIMITED

Report Documentation Page

Form Approved
OMB No. 0704-0188

Public reporting burden for the collection of information is estimated to average 1 hour per response, including the time for reviewing instructions, searching existing data sources, gathering and maintaining the data needed, and completing and reviewing the collection of information. Send comments regarding this burden estimate or any other aspect of this collection of information, including suggestions for reducing this burden, to Washington Headquarters Services, Directorate for Information Operations and Reports, 1215 Jefferson Davis Highway, Suite 1204, Arlington VA 22202-4302. Respondents should be aware that notwithstanding any other provision of law, no person shall be subject to a penalty for failing to comply with a collection of information if it does not display a currently valid OMB control number.

1. REPORT DATE 13 JUN 2008		2. REPORT TYPE N/A		3. DATES COVERED -	
4. TITLE AND SUBTITLE SMC-S-008 (2008) Electromagnetic Compatibility Requirements for Space Equipment and Systems				5a. CONTRACT NUMBER	
				5b. GRANT NUMBER	
				5c. PROGRAM ELEMENT NUMBER	
6. AUTHOR(S)				5d. PROJECT NUMBER	
				5e. TASK NUMBER	
				5f. WORK UNIT NUMBER	
7. PERFORMING ORGANIZATION NAME(S) AND ADDRESS(ES) USAF Space and Missile Systems Center				8. PERFORMING ORGANIZATION REPORT NUMBER	
9. SPONSORING/MONITORING AGENCY NAME(S) AND ADDRESS(ES)				10. SPONSOR/MONITOR'S ACRONYM(S)	
				11. SPONSOR/MONITOR'S REPORT NUMBER(S)	
12. DISTRIBUTION/AVAILABILITY STATEMENT Approved for public release, distribution unlimited					
13. SUPPLEMENTARY NOTES					
14. ABSTRACT					
15. SUBJECT TERMS					
16. SECURITY CLASSIFICATION OF:			17. LIMITATION OF ABSTRACT UU	18. NUMBER OF PAGES 123	19a. NAME OF RESPONSIBLE PERSON
a. REPORT unclassified	b. ABSTRACT unclassified	c. THIS PAGE unclassified			

FOREWORD

1. This standard defines the Government's requirements and expectations for contractor performance in defense system acquisitions and technology developments.
2. This new-issue SMC standard comprises the text of The Aerospace Corporation report number TOR-2005(8583)-1.
3. Beneficial comments (recommendations, changes, additions, deletions, etc.) and any pertinent data that may be of use in improving this standard should be forwarded to the following addressee using the Standardization Document Improvement Proposal appearing at the end of this document or by letter:

Division Chief, SMC/EAE
SPACE AND MISSILE SYSTEMS CENTER
Air Force Space Command
483 N. Aviation Blvd.
El Segundo, CA 90245

4. This standard has been approved for use on all Space and Missile Systems Center/Air Force Program Executive Office - Space development, acquisition, and sustainment contracts.

James Horejsi, Col, USAF
SMC Chief Engineer

CONTENTS

1. SCOPE	1
1.1 Purpose	1
1.2 Application	1
1.3 Tailoring.....	1
1.4 Structure	1
2. APPLICABLE DOCUMENTS	17
2.1 Government Documents.....	17
2.2 Non-Government Documents	17
2.3 Reference Documents	18
2.4 Order of Precedence.	20
3. ABBREVIATIONS, ACRONYMS AND DEFINITIONS	21
3.1 General.....	21
3.2 Abbreviations and Acronyms	21
3.3 Definitions	22
4. GENERAL REQUIREMENTS	27
4.1 Units and Subsystems	27
4.2 Vehicle.....	31
4.3 EMISMs	32
4.4 Service Life.....	34
5. DETAILED REQUIREMENTS, GROUND UNITS AND SUBSYSTEMS	35
5.1 Ground Support Equipment	35

**6. DETAILED REQUIREMENTS,
SPACE AND LAUNCH UNITS AND SUBSYSTEMS 37**

POWER LINE CONDUCTED EMISSIONS, SPACE EQUIPMENT

6.01 Conducted Emissions, Power and Command/Control Lines,
30Hz-50MHz (CE101/102A) 37

6.02 *(Reserved)* 40

6.03 Conducted Emissions, Common Mode to Structure, Frequency Domain,
30Hz-50MHz 40

6.04 Conducted Emissions, Common Mode to Structure, Time Domain 42

6.05 *(Reserved)* 42

6.06 Conducted Emissions, Ripple and Periodic Transients, Power and
Command/Control Lines 43

6.07 Conducted Emissions, Short-Duration Aperiodic Transients, Power and
Command/Control Lines (CE07) 45

6.08 Conducted Emissions, Inrush Current, Power and Command/Control Lines... 46

6.09 *(Reserved)* 47

POWER LINE CONDUCTED SUSCEPTIBILITY, SPACE EQUIPMENT

6.10 Conducted Susceptibility, Power and Command/Control Lines,
30Hz-150kHz (CS101) 47

6.11 Conducted Susceptibility, Power and Command/Control Lines,
150kHz-50MHz (CS02) 51

6.12 Conducted Susceptibility, Short-Duration High-Level Aperiodic Transients,
Power and Command/Control Lines (CS06) 53

6.13 Conducted Susceptibility, Aperiodic Surges, Operate Through, Power and
Command/Control Lines 58

6.14 Conducted Susceptibility, Aperiodic Surges, Survival and Outrush Current,
Power and Command/Control Lines 59

6.15 *(Reserved)* 59

6.16 Conducted Susceptibility, Ground Plane Injection, 30Hz-150kHz 60

6.17 Conducted Susceptibility, Ground Plane Injection, 150kHz-100MHz 62

6.18 Conducted Susceptibility, Ground Plane Injection, Transient 63

6.19 *(Reserved)* 65

ANTENNA INTERFACES AND RADIATED INTERFACES, SPACE EQUIPMENT

6.20 *(Reserved)* 65

6.21 Conducted Susceptibility, Antenna Port, Intermodulation, 15kHz-40GHz
(CS103) 65

6.22 Conducted Susceptibility, Antenna Port, Rejection of Undesired Signals,
30Hz-40GHz (CS104) 66

6.23	Conducted Susceptibility, Antenna Port, Cross Modulation, 30Hz-40GHz (CS105)	67
6.24	Radiated Emissions, Electric Field, 14kHz-18GHz (RE102)	67
6.25	Conducted Emissions, Antenna Terminal, 10kHz-100GHz (CE106)	72
6.26	Radiated Emissions, (Transmitter) Antenna Spurious and Harmonic Outputs, 10kHz-100GHz (RE103)	73
6.27	Radiated Susceptibility, Electric Field, 10kHz-40GHz (RS103)	74
6.28	Conducted Susceptibility, Antenna Port Direct Injection (RS103alt)	82
6.29	Radiated Susceptibility, Wideband	82
CABLE BUNDLE INTERFACES AND MAGNETICS, SPACE EQUIPMENT		
6.30	Conducted Susceptibility, Bulk Cable Injection, 10kHz-200MHz (CS114)	83
6.31	Conducted Susceptibility, Bulk Cable Injection, Impulse Excitation (CS115)...	84
6.32	Conducted Susceptibility, Damped Sinusoidal Transients, Cables and Power Leads, 10kHz-100MHz (CS116)	85
6.33	Radiated Emissions, (AC) Magnetic Field, 30Hz-100kHz (RE101).....	86
6.34	Radiated Emissions, DC Magnetic Field.....	86
6.35	Radiated Emissions, DC Magnetic Dipole Moment	88
6.36	Radiated Susceptibility, (AC) Magnetic Field, 30Hz-100kHz (RS101)	88
6.37	Radiated Susceptibility, Magnetic and Electric (Induction) Fields, Spikes and Power Frequencies (RS02).....	89
6.38	<i>(Reserved)</i>	91
6.39	<i>(Reserved)</i>	91
PASSIVE INTERMODULATION AND ENVIRONMENTS, SPACE EQUIPMENT		
6.40	Passive Intermodulation (PIM), General	92
6.41	Passive Intermodulation (PIM), Conducted RF Paths to RF Interfaces	93
6.42	Electrostatic Discharge (ESD), Surface Materials.....	94
6.43	Electrostatic Discharge (ESD), Susceptibility.....	95
6.44	Bulk Charging	96
6.45	EMP (RS105).....	97
6.46	Multipaction.....	97
6.47	Corona.....	97
6.48	Lightning	97
6.49	<i>(Reserved)</i>	98
6.50	<i>(Reserved)</i>	98
POWER ISOLATION AND GROUNDING, SPACE EQUIPMENT		
6.51	Power Isolation and Grounding	98

7. DETAILED REQUIREMENTS, SPACE VEHICLES	101
7.1 Vehicle EMC	101
7.2 <i>(Reserved)</i>	105
7.3 Vehicle Passive Intermodulation (PIM)	105
7.4 Vehicle Triboelectric Charging	107
7.5 Vehicle EMP	107
7.6 Vehicle Lightning	107
7.7 Vehicle Bonding	107
7.8 Vehicle Grounding	108
APPENDIX A. REQUIREMENTS' PRIMARY HERITAGE	109

FIGURES

Figure 6.01c1-1.	Limit Curve, CE101/102A.	38
Figure 6.03c1-1.	Common Mode Conducted Emissions, Frequency Domain.....	41
Figure 6.10c1-1.	CS101 Voltage Limits.	50
Figure 6.10c2-1.	CS101 Power Limits.	50
Figure 6.11d1-1.	Test Setup (CS02).	53
Figure 6.12c-1.	Acceptable Waveforms for Requirements 6.12(CS06) and 6.37(RS02).	54
Figure 6.12d1-1.	Spike Susceptibility, AC or DC Power, Series Injection (CS06)...	57
Figure 6.12d1-2.	Spike Susceptibility, DC Power, Parallel Injection (CS06).	57
Figure 6.12d1-3.	Calibration of High Source Impedance Spike Generator (CS06).	57
Figure 6.16c-1.	Current Limit for Ground Plane Injection, 30Hz-150kHz.	60
Figure 6.16d-1.	Test Setup for Ground Plane Injection, 30Hz-150kHz.	61
Figure 6.17d-1.	Test Setup for Ground Plane Injection, 150kHz-100MHz.	63
Figure 6.18d-1.	Test Setup for Ground Plane Injection, Transient.	65
Figure 6.24c1-1.	RE102 Limits.	71
Figure 6.24c1-2.	RE102 100MHz-18GHz Detail.	71
Figure 6.27c1-1.	RS103 Limits and Environments.....	81
Figure 6.37d-1.	Cable Test Setup (RS02).....	91
Figure 6.37d-2.	Case Test Setup (RS02).....	91

TABLES

Table 1.2.2-1.	Applicability of Requirements, Verification Methods and Tailoring Paragraphs	2
Table 4.3-1.	EMI Safety Margins	33
Table 5.1e-1.	MIL-STD-464A RFI Requirements for Ground Equipment	35
Table 6.27c1-1.	Minimum RFI Susceptibility Levels (RS103).....	74
Table 6.27c3-1.	RFI Survival Levels while Off and Stowed (RS103).....	75
Table 6.27e2-1.	RFI Susceptibility and Survival Limits (V/m) for Worst-Case (Polar) Orbit, Any Launch Area (RS103)	78
Table 7.1d2-1.	Some Vehicle Test Configuration Parameters.....	102

1. SCOPE

1.1 Purpose

The purpose of this document is to minimize risk to space programs in the area of electromagnetic compatibility (EMC).

1.2 Application

1.2.1 Document Applicability

This document is applicable to launch and space vehicles, their units and subsystems, plus the associated ground, airborne or spaceborne operational and support elements of the space system. This document does not apply to the facilities which house ground system segments of space systems (see MIL-STD-1542), nor does it apply to printed wiring board assemblies or individual microcircuits.

1.2.2 Requirement Applicability

The primary Requirements (*e.g.*, 4.1, 6.05, 7.7), subrequirements (*e.g.*, 4.2c2, 6.10c3, 7.1c1), verification methods (*e.g.*, 4.3d1, 6.14d2, 7.7d) and tailoring (*e.g.*, 4.1e1, 6.03e, 7.3e3) given in Sections 4 to 7 of this document are applicable in accordance with Table 1.2.2-1. They are also portion marked in the text in accordance with the explanation at the beginning of Table 1.2.2-1. All paragraphs under a primary Requirement have the same applicability as given at the primary Requirement title, unless otherwise marked.

1.3 Tailoring

Space systems consist for the most part of existing and modified equipment, combined with some new equipment. The diversity of the missions (launch, communication, weather, navigation, remote sensing, exploration) and equipment, plus the unique approaches of the contractors, make tailoring of standard requirements mandatory. Many requirements in this document include self-tailoring, but this does not necessarily obviate the need for additional tailoring. For example, some requirements may not be applicable to particular equipment, and occasionally there is no safe and effective method of verification of a given requirement for a unit or subsystem. Furthermore, program risk is reduced by levying more stringent requirements in the beginning, when equipment and system characteristics are not yet fully known. As the characteristics become better defined, requirements may be relaxed, consistent with acceptable program risk levels.

1.4 Structure

1.4.1 Requirements

The requirements in this document are grouped by type.

Each requirement includes a purpose, applicability, the actual requirement or sub-requirements, verification method or methods, and tailoring guidelines (in some cases). The verification methods ensure that the requirements have been satisfied, and the tailoring guidelines attempt to make each requirement as self-tailoring as possible.

1.4.2 Reserved Paragraphs

This is intended to be a “living” document, which will be updated in the future. “Reserved” paragraphs have been placed within the requirements sections of this document, so that if requirements are deleted or new requirements are added in future releases, paragraph references in this document or other documents will remain meaningful.

Table 1.2.2-1. Applicability of Requirements, Verification Methods and Tailoring Paragraphs

- A (Applicable) Applicable to all equipment for all procurements, unless specifically tailored out by the program procurement documentation. “A” is used only in the Table, not in the text: unmarked text follows the applicability of the primary Requirement title, and unmarked titles are the same as being marked “A”.
 - L (Limited) Applicable only to special classes of equipment (e.g., receivers and transmitters), but otherwise applicable to that equipment for all procurements, unless tailored out. Used in Table and for portion marking text.
 - P (Procurement-specified) Applicable for a specific program, only if specified in program procurement documentation. Used in Table and for portion marking text. If the title of a Requirement is marked (**P**) and a paragraph under the title is also so marked, it means that the paragraph must be levied specifically by the procuring authority to be applicable to the program, in addition to levying the primary Requirement.
 - X Same as a higher-level paragraph within the same primary Requirement. Requires a conditional statement in the paragraph indicating the higher-level paragraph. For instance, a verification applicability is X if it has a corresponding subrequirement which is P. Hence, if the subrequirement is levied, the verification will apply, but if the subrequirement is not levied, the verification will not apply, automatically. This avoids accidentally levying the subrequirement but not the verification, or *vice versa*. Used in Table and for portion marking text.
 - N (None) Title only or reserved paragraph. Used only in Table, not in text.
- Greyed-out empty applicability table cells match the applicability of the primary Requirement. If greyed out and containing an “N”, applicability is not relevant, e.g., for reserved paragraphs and chapter titles.

Req. #	Title	App.
4.	GENERAL REQUIREMENTS	N
4.1	Units and Subsystems	A
4.1c1	Requirement: General requirements of MIL-STD-461F	
4.1c2	Requirement: Non-developmental items (NDI)	
4.1c3	Requirement: Requirement matrix in MIL-STD-461F	
4.1c4	Requirement: Cables and loads	
4.1c5	Requirement: Environments	

Req. #	Title	App.
4.1c6	Requirement: Applicable interfaces	
4.1c7	Requirement: Modes of operation	
4.1c8	Requirement: Operational voltages	
4.1c9	Requirement: RMS units of measurements	
4.1c10	Requirement: Secondary power	P
4.1d1	Verification: General	
4.1d2	Verification: Test methods of MIL-STD-461F	
4.1d3	Verification: Non-developmental items (NDI)	
4.1d4	Verification: Test-like-you-fly	
4.1d5	Verification: Cables and loads	
4.1d6	Verification: Modes of operation	P
4.1d7	Verification: Operational voltage	
4.1d8	Verification: Test signal modulation	
4.1d9	Verification: LISNs	
4.1d10	Verification: Test methods using LISNs, detuning capacitor and resistor	
4.1d11	Verification: Power referencing	
4.1d12	Verification: Cables from shielded enclosure power entry to LISNs	
4.1d13	Verification: Electromagnetic ambient during radiated tests	
4.1d14	Verification: Test equipment sensitivities	
4.1d15	Verification: Ordnance	
4.1d16	Verification: Primary and redundant sides	
4.1e1	Tailoring: Limits	P
4.1e2	Tailoring: Secondary power	P
4.2	Vehicle	A
4.2c1	Requirement: Applicable interfaces	
4.2c2	Requirement: Segment and vehicle interfaces	
4.2c3	Requirement: Exemption of interfaces	
4.2c4	Requirement: Non-developmental items (NDI)	
4.2c5	Requirement: Environments	
4.2c6	Requirement: Secondary power	P
4.2d1	Verification: General	
4.2d2	Verification: Test methods of MIL-STD-461F	

Req. #	Title	App.
4.2d3	Verification: Non-developmental items (NDI)	
4.2d4	Verification: Test-like-you-fly	
4.2d5	Verification: Test signal modulation	
4.2d6	Verification: Electromagnetic ambient during radiated tests	
4.2d7	Verification: Test equipment sensitivities	
4.2d8	Verification: Primary and redundant sides	
4.2e1	Tailoring: Limits	P
4.2e2	Tailoring: Secondary power	P
4.3	EMISMs	A
4.3c1	Requirement: Basic	
4.3c2	Requirement: Receiver and transmitter passbands	
4.3d1	Verification: Basic	
4.3d2	Verification: Timing	
4.3e	Tailoring: Program Classes	
4.4	Service Life	A
4.4c	Requirement	
4.4d	Verification	
5.	DETAILED REQUIREMENTS, GROUND UNITS AND SUBSYSTEMS	N
5.1	Ground Support Equipment	A
5.1c	Requirement	
5.1d	Verification	
5.1e	Tailoring: RFI environments	P
6.	DETAILED REQUIREMENTS, SPACE AND LAUNCH UNITS AND SUBSYSTEMS	N
<i>POWER LINE CONDUCTED EMISSIONS, SPACE EQUIPMENT</i>		
6.01	Conducted Emissions, Power and Command/Control Lines, 30Hz-50MHz (CE101/102A)	A
6.01c1	Requirement: Basic, 30Hz-50MHz	
6.01c2	Requirement: Frequency range extension 0.1Hz-30Hz	P
6.01c3	Requirement: Frequency range extension 50MHz-400MHz	P
6.01c4	Requirement: Frequency range extension 50MHz-1GHz	P
6.01d1	Verification: Basic, 30Hz-50MHz	
6.01d2	Verification: Frequency range extensions	X

Req. #	Title	App.
6.01d3	Tailoring: Operational voltages, minimum and maximum	P
6.01e1	Tailoring: Pulse loads	
6.01e2	Tailoring: High frequency limits	
6.02	<i>Reserved</i>	N
6.03	Conducted Emissions, Common Mode to Structure, Frequency Domain, 30Hz-50MHz	P
6.03c1	Requirement: Basic, 30Hz-50MHz	
6.03c2	Requirement: Frequency range extension 0.1Hz-30Hz	P
6.03c3	Requirement: Frequency range extension 50MHz-400MHz	P
6.03d1	Verification: Basic, 30Hz-50MHz	
6.03d2	Verification: Alternative method	
6.03d3	Verification: Frequency range extensions	X
6.03e	Tailoring: Exemptions	P
6.04	Conducted Emissions, Common Mode to Structure, Time Domain (TBD)	P
6.04c	Requirement	
6.04d	Verification	
6.04e	Tailoring: Exemptions	P
6.05	<i>Reserved</i>	N
6.06	Conducted Emissions, Ripple and Periodic Transients, Power and Command/Control Lines	A
6.06c1	Requirement: Low BW ripple	
6.06c2	Requirement: High BW ripple	P
6.06d1	Verification: Basic	
6.06d2	Verification: Operational voltage and modes	
6.06d3	Verification: Operational voltages, minimum and maximum	P
6.06e	Tailoring: Pulse loads	
6.07	Conducted Emissions, Short-Duration Aperiodic Transients, Power and Command/Control Lines (CE07)	A
6.07c	Requirement	
6.07d1	Verification: Basic	
6.07d2	Verification: Operational voltages and modes	

Req. #	Title	App.
6.07d3	Verification: Modes and transitions	
6.08	Conducted Emissions, Inrush Current, Power and Command/Control Lines	A
6.08c1	Requirement: Inrush current, initial power application	
6.08c2	Requirement: Inrush current, normal operations	
6.08d1	Verification: Basic	
6.08d2	Verification: Unit operational voltage, initial power application	
6.08d3	Verification: Unit operational voltage, normal operations	
6.08d4	Verification: Test equipment capabilities	
6.08e1	Tailoring: Soft start	P
6.08e2	Tailoring: Very high currents	
6.09	<i>Reserved</i>	N
POWER LINE CONDUCTED SUSCEPTIBILITY, SPACE EQUIPMENT		
6.10	Conducted Susceptibility, Power and Command/Control Lines, 30Hz to 150kHz (CS101)	A
6.10c1	Requirement: Basic, voltage	
6.10c2	Requirement: Basic, power	
6.10c3	Requirement: Frequency range extension 0.1Hz-30Hz	P
6.10c4	Requirement: Exceeding operational voltage range	
6.10d1	Verification: Basic	
6.10d2	Verification: 10uF capacitor across EUT power input leads at LISNs	
6.10d3	Verification: Frequency range extension	X
6.10d4	Verification: Unit operational voltage levels	
6.10d5	Verification: Alternative operational voltage and test limits	
6.11	Conducted Susceptibility, Power and Command/Control Lines, 150kHz-50MHz (CS02)	A
6.11c1	Requirement: Basic, 150kHz-50MHz	
6.11c2	Requirement: Frequency range extension 50MHz-400MHz	P
6.11c3	Requirement: Frequency range extension 50MHz-1GHz	P
6.11d1	Verification: Basic, 150kHz-50MHz	
6.11d2	Verification: Frequency range extensions	X
6.11d3	Verification: Operational voltages, minimum and maximum	P
6.11d4	Verification: Test signal modulation	

Req. #	Title	App.
6.12	Conducted Susceptibility, Short-Duration High-Level Aperiodic Transients, Power and Command/Control Lines (CS06)	A
6.12c	Requirement	
6.12d1	Verification: Basic	
6.12d2	Verification: Unit operational voltages, minimum and maximum	P
6.12e	Tailoring: Limits and bus voltages	
6.13	Conducted Susceptibility, Aperiodic Surges, Operate Through, Power and Command/Control Lines	A
6.13c1	Requirement: Operating through positive surges	
6.13c2	Requirement: Operating through negative surges	
6.13d	Verification	
6.14	Conducted Susceptibility, Aperiodic Surges, Survival and Outrush Current, Power and Command/Control Lines	A
6.14c1	Requirement: Surviving positive surges, general equipment	
6.14c2	Requirement: Surviving negative surges, general equipment	
6.14c3	Requirement: Surviving positive surges, essential equipment	
6.14c4	Requirement: Surviving negative surges, essential equipment	
6.14c5	Requirement: Outrush current	
6.14d1	Verification: Basic	
6.14d2	Verification: Outrush current	
6.14e	Tailoring: Outrush current	P
6.15	<i>Reserved</i>	N
6.16	Conducted Susceptibility, Ground Plane Injection, 30Hz-150kHz	P
6.16c	Requirement	
6.16d	Verification	
6.17	Conducted Susceptibility, Ground Plane Injection, 150kHz-100MHz	P
6.17c	Requirement	
6.17d	Verification	
6.18	Conducted Susceptibility, Ground Plane Injection, Transient	P
6.18c	Requirement	
6.18d	Verification	
6.19	<i>Reserved</i>	N

Req. #	Title	App.
ANTENNA INTERFACES AND RADIATED INTERFACES, SPACE EQUIPMENT		
6.20	<i>Reserved</i>	N
6.21	Conducted Susceptibility, Antenna Port, Intermodulation, 15kHz-40GHz (CS103)	L
6.21c	Requirement	
6.21d	Verification	
6.22	Conducted Susceptibility, Antenna Port, Rejection of Undesired Signals, 30Hz-40GHz (CS104)	L
6.22c	Requirement	
6.22d	Verification	
6.23	Conducted Susceptibility, Antenna Port, Cross Modulation, 30Hz-40GHz (CS105)	L
6.23c	Requirement	
6.23d	Verification	
6.24	Radiated Emissions, Electric Field, 14kHz-18GHz (RE102)	A
6.24c1	Requirement: Basic, 14kHz-18GHz	
6.24c2	Requirement: Frequency range extension 20Hz-14kHz	P
6.24c3	Requirement: Frequency range extension 18GHz-100GHz	P
6.24c4	Requirement: Receiver notches	
6.24c5	Requirement: Standard receiver notches	
6.24d1	Verification: Basic, 14kHz-18GHz	
6.24d2	Verification: Extended frequency range 20Hz-14kHz	X
6.24d3	Verification: Extended frequency range 18GHz-100GHz	X
6.24d4	Verification: Platform receiver passband and LNA bandwidths	
6.24d5	Verification: Alternate receiver notch test methods	P
6.24d6	Verification: Dwell times	
6.24d7	Verification: Dwell times, special events	P
6.24d8	Verification: Transmitters	
6.24d9	Verification: Solar array emissions	
6.24d10	Verification: Power line noise injection	P
6.24e1	Tailoring: Receiver notches	P
6.24e2	Tailoring: Bandwidth correction factors	P
6.24e3	Tailoring: Scans above 18GHz	P

Req. #	Title	App.
6.24e4	Tailoring: Power line noise injection	P
6.25	Conducted Emissions, Antenna Terminal, 10kHz-100GHz (CE106)	L
6.25c1	Requirement: Basic	
6.25c2	Requirement: Receiver notches	
6.25c3	Requirement: Standard receiver notches	
6.25c4	Requirement: NTIA requirements	
6.25d	Verification	
6.25e	Tailoring: Scans above 40GHz	P
6.26	Radiated Emissions, (Transmitter) Antenna Spurious and Harmonic Outputs, 10kHz-100GHz (RE103)	L
6.26c1	Requirement: Basic	
6.26c2	Requirement: Transmitters testable to Requirement 6.25(CE106)	P
6.26c3	Requirement: Receiver notches	
6.26c4	Requirement: Standard receiver notches	
6.26c5	Requirement: NTIA requirements	
6.26d1	Verification: Basic	
6.26d2	Verification: Receiver notches	
6.26e1	Tailoring: Transmitters testable to Requirement 6.25(CE106)	
6.26e2	Tailoring: Scans above 40GHz	P
6.27	Radiated Susceptibility, Electric Field, 10kHz-40GHz (RS103)	A
6.27c1	Requirement: Basic, 10kHz-40GHz, operational	
6.27c2	Requirement: Platform transmitters	
6.27c3	Requirement: Equipment survival	P
6.27c4	Requirement: Frequency range extension 40GHz-100GHz, platform sources	
6.27c5	Requirement: Frequency range extension 40GHz-100GHz, external sources	P
6.27c6	Requirement: Antenna-connected equipment LNAs, operate-through	
6.27c7	Requirement: Antenna-connected equipment LNAs, survival	P
6.27c8	Requirement: Antenna-connected equipment passbands, operate-through	
6.27c9	Requirement: Antenna-connected equipment passbands, survival	P
6.27d1	Verification: Basic, 10kHz-100GHz	

Req. #	Title	App.
6.27d2	Verification: Test signal modulation	
6.27d3	Verification: Antenna-connected equipment	
6.27d4	Verification: Dwell times	
6.27d5	Verification: Combining tests	
6.27e1	Tailoring: Frequency range over 100GHz	P
6.27e2	Tailoring: Increased levels	
6.27e3	Tailoring: Reduced levels	P
6.27e4	Tailoring: Receivers	P
6.27e5	Tailoring: High power microwave (HPM)	P
6.27e6	Tailoring: Mission phases	
6.27e7	Tailoring: Combining test levels	
6.28	Conducted Susceptibility, Antenna Port Direct Injection (RS103alt)	L
6.28c	Requirement	
6.28d1	Verification	
6.28d2	Verification: Test signal modulation	
6.28d3	Verification: Dwell times	
6.29	Radiated Susceptibility, Wideband (TBD)	P
6.29c	Requirement	
6.29d	Verification	
6.29e	Tailoring: Verification dwell times	
CABLE BUNDLE INTERFACES AND MAGNETICS, SPACE EQUIPMENT		
6.30	Conducted Susceptibility, Bulk Cable Injection, 10kHz-200MHz (CS114)	A
6.30c1	Requirement: Basic, 10kHz to 200MHz	
6.30c2	Requirement: Frequency range extension 200MHz-400MHz	P
6.30d1	Verification: Basic, 10kHz-200MHz	
6.30d2	Verification: Frequency range extension	X
6.30d3	Verification: Test signal modulation	
6.30e	Tailoring: Shielded cables	P
6.31	Conducted Susceptibility, Bulk Cable Injection, Impulse Excitation (CS115)	A
6.31c	Requirement	

Req. #	Title	App.
6.31d	Verification	
6.31e	Tailoring: Shielded cables	P
6.32	Conducted Susceptibility, Damped Sinusoidal Transients, Cables and Power Leads, 10kHz-100MHz (CS116)	A
6.32c	Requirement	
6.32d1	Verification: Basic	
6.32d2	Verification: Power off	P
6.32e	Tailoring: Shielded cables	P
6.33	Radiated Emissions, (AC) Magnetic Field, 30Hz-100kHz (RE101)	A
6.33c1	Requirement: Basic, 30Hz-100kHz	
6.33c2	Requirement: Frequency range extension 0.1Hz-30Hz	P
6.33d1	Verification	
6.33d2	Verification: Frequency range extension 0.1Hz-30Hz	X
6.34	Radiated Emissions, DC Magnetic Field	P
6.34c1	Requirement: Basic	
6.34c2	Requirement: Maximum limit	
6.34d1	Verification: Basic	
6.34d2	Verification: Units sensitive to DC magnetic fields	
6.34d3	Verification: Sources of DC magnetic fields	
6.35	Radiated Emissions, DC Magnetic Dipole Moment	P
6.35c1	Requirement: Basic	
6.35c2	Requirement: Maximum limit	
6.35d1	Verification: Basic	
6.35d2	Verification: Sources of DC magnetic dipole moments	
6.36	Radiated Susceptibility, (AC) Magnetic Field, 30Hz-100kHz (RS101)	A
6.36c1	Requirement: Basic, 30Hz-100kHz	
6.36c2	Requirement: Frequency range extension 0.1Hz-30Hz	P
6.36d1	Verification	
6.36d2	Verification: Frequency range extension 0.1Hz-30Hz	X
6.36d3	Verification: Dwell times	

Req. #	Title	App.
6.37	Radiated Susceptibility, Magnetic and Electric (Induction) Fields, Spikes and Power Frequencies (RS02)	A
6.37c1	Requirement: Spikes	
6.37c2	Requirement: Power frequency	L
6.37d	Verification	
6.37e	Tailoring: Power frequency	
6.38	<i>Reserved</i>	N
6.39	<i>Reserved</i>	N
PASSIVE INTERMODULATION AND ENVIRONMENTS, SPACE EQUIPMENT		
6.40	Passive Intermodulation (PIM), General	A
6.40c1	Requirement: Thermal blankets	
6.40c2	Requirement: Braided metallic materials	
6.40c3	Requirement: Electrical bonds	
6.40c4	Requirement: Incidental contacts	
6.40c5	Requirement: Semiconductor devices	
6.40d	Verification	
6.40e1	Tailoring: Exemption	
6.40e2	Tailoring: Test frequencies	P
6.40e3	Tailoring: RF-shielded vehicle structure	P
6.41	Passive Intermodulation (PIM), Conducted RF Paths to RF Interfaces	A
6.41c	Requirement	
6.41d	Verification	
6.41e1	Tailoring: Exemption	
6.41e2	Tailoring: Test frequencies	P
6.42	Electrostatic Discharge (ESD), Surface Materials	A
6.42c1	Requirement: Uncoated bulk materials	
6.42c2	Requirement: Partially conductive surface coating on conductor	
6.42c3	Requirement: Partially conductive surface coating on insulator	
6.42c4	Requirement: Two partially conductive surface coatings on insulator	
6.42d	Verification	
6.42e	Tailoring	P

Req. #	Title	App.
6.43	Electrostatic Discharge (ESD), Susceptibility	A
6.43c1	Requirement: Air discharge (indirect discharge)	
6.43c2	Requirement: Contact discharge (direct discharge)	
6.43c3	Requirement: Vehicle mounting surface discharge	
6.43d	Verification	
6.43e1	Tailoring: Contact discharge	P
6.43e2	Tailoring: Air discharge	P
6.44	Bulk Charging (TBD)	P
6.45	EMP (RS105), Space and Launch Units and Subsystems	P
6.45c	Requirement	
6.45d	Verification	
6.46	Multipaction	L
6.46c	Requirement	
6.46d	Verification	
6.47	Corona (TBD)	P
6.48	Lightning	P
6.48c1	Requirement: Induced transient susceptibility	
6.48c2	Requirement: Direct effects	
6.48d	Verification	
6.48e1	Tailoring: General	
6.48e2	Tailoring: Alternative requirements	
6.49	<i>Reserved</i>	N
POWER ISOLATION AND GROUNDING, SPACE EQUIPMENT		
6.50	<i>Reserved</i>	N
6.51	Power Isolation and Grounding	A
6.51c1	Requirement: Primary power isolation from chassis	
6.51c2	Requirement: Primary power isolation from telemetry	
6.51c3	Requirement: Secondary power referencing	
6.51c4	Requirement: Secondary power isolation from primary power	
6.51c5	Requirement: Bonding to vehicle structure	
6.51d1	Verification: Isolation	

Req. #	Title	App.
6.51d2	Verification: Bonding	
6.51e1	Tailoring: Power return on vehicle structure	P
6.51e2	Tailoring: Secondary power referencing	P
7.	DETAILED REQUIREMENTS, SPACE VEHICLES	N
7.1	Vehicle EMC	A
7.1c1	Requirement: Basic	
7.1c2	Requirement: EMISMs	
7.1d1	Verification: Basic	
7.1d2	Verification: Self-compatibility	
7.1d3	Verification: Self-compatibility and EMISMs, conducted regime	
7.1d4	Verification: Self-compatibility and EMISMs, radiated emissions	
7.1d5	Verification: External RFI compatibility (RS103) and EMISMs	
7.1d6	Verification: Ordnance EMISMs, with external RFI (RS103)	
7.1d7	Verification: Self-compatibility and EMISMs, PIM	P
7.1d8	Verification: Conducted emissions and EMISMs, with external RFI (RS103)	P
7.1d9	Verification: PIM and EMISMs, w/ external RFI (RS103)	P
7.1d10	Verification: Secondary power	P
7.1d11	Verification: Unit-level test methods	
7.1e1	Tailoring: Program classes	
7.1e2	Tailoring: Combining RFI susceptibility (RS103) test levels	
7.1e3	Tailoring: PIM	P
7.1e4	Tailoring: Radiated regime frequency ranges	
7.1e5	Tailoring: Reduced e-field emissions (RE102) frequency ranges	P
7.1e6	Tailoring: Radiated regime BWs	
7.1e7	Tailoring: Radiated regime dwell times	
7.1e8	Tailoring: Equipment deployment	P
7.1e9	Tailoring: Combining tests	P
7.1e10	Tailoring: Secondary power	P
7.1e11	Tailoring: Unit-level test methods	P
7.2	<i>Reserved</i>	N

Req. #	Title	App.
7.3	Vehicle Passive Intermodulation (PIM)	A
7.3c1	Requirement: Electrical bonds	
7.3c2	Requirement: Incidental contacts	
7.3c3	Requirement: Semiconductor devices	
7.3d	Verification	
7.3e1	Tailoring: Exemption	P
7.3e2	Tailoring: Test frequencies	P
7.3e3	Tailoring: RF-shielded vehicle structure	P
7.4	Vehicle Triboelectric Charging	A
7.4c	Requirement	
7.4d	Verification	
7.5	Vehicle EMP (TBD)	P
7.6	Vehicle Lightning (TBD)	P
7.7	Vehicle Bonding	A
7.7c1	Requirement: Cable, connector, ground reference system and related bonds	
7.7c2	Requirement: ESD mitigation bonds	
7.7d	Verification	
7.8	Vehicle Grounding (TBD)	P
7.8c	Requirement	

2. APPLICABLE DOCUMENTS

2.1 Government Documents

2.1.1 Department of Defense Documents, Drawings and Publications

The following documents form a part of this document to the extent specified herein.

1. **MIL-STD-461F**, Requirements for the Control of Electromagnetic Interference Characteristics of Subsystems and Equipment, Department of Defense, 10 December 2007.
2. **MIL-STD-464A**, Electromagnetic Environmental Effects Requirements for Systems, Department of Defense, 19 December 2002.

2.1.2 Other Government Documents, Drawings and Publications

The following documents form a part of this document to the extent specified herein. Unless otherwise specified, the issues of the documents are the current versions.

1. **Aerospace Report No. TOR-2005(8583)-2**, Electrical Power Systems, Direct Current, Space Vehicle Design Requirements, The Aerospace Corp., 13 January 2005.
2. **Aerospace Report No. TR-2004(8583)-1 (proposed MIL-STD-1540E)**, Test Requirements for Launch, Upper-Stage, and Space Vehicles, The Aerospace Corp., 31 January 2004.
3. **AFSPCMAN 91-710**, Range Safety User Requirements Manual, Air Force Space Command.
4. **Evolved Expendable Launch Vehicle Standard Interface Specification (EELV SIS)**, Version 6.0, EELV Program Office in conjunction with The Aerospace Corp. and the USAF, SMC/MVS, 5 September 2000.
5. **Manual of Regulations and Procedures for Federal Radio Frequency Management**, National Telecommunication and Information Administration (NTIA).

2.2 Non-Government Documents

The following documents form a part of this document to the extent specified herein. Unless otherwise specified, the issues of the documents are the current versions.

1. **AIAA S-122-2007**, Electrical Power Systems for Unmanned Spacecraft, American Institute of Aeronautics and Astronautics, 5 January 2007.
2. **ANSI/IEEE C63.14**, Standard Dictionary for Technologies of Electromagnetic Compatibility (EMC), Electromagnetic Pulse (EMP), and Electrostatic Discharge (ESD).
3. **ECSS-E-20-01A**, Space Engineering - Multipaction Design and Test, European Space Agency (ESA) for the European Cooperation for Space Standardization (ECSS), 5 May 2003.
4. **IEC 61000-4-2**, Testing and Measurement Techniques - Electrostatic Discharge Immunity Test, International Electrotechnical Commission.

5. **RTCA/DO-160 (ISO 7137) (EUROCAE ED-14)**, Environmental Conditions and Test Procedures for Airborne Equipment, Radio Technical Commission for Aeronautics, Washington, DC.

2.3 Reference Documents

2.3.1 General

1. **AIAA S-121-200X**, Electromagnetic Compatibility Requirements for Space Equipment and System, American Institute of Aeronautics and Astronautics, DRAFT, XX Month 200X.
2. **DOD-W-83575A**, Wiring Harness, Space Vehicle, Design and Testing, General Specification for, USAF.
3. **Engineering Practice Study, Results of Detailed Comparison of Individual EMC Requirements and Test Procedures Delineated in Major National and International Commercial Standards with Military Standard MIL-STD-461E**, DoD/Industry Electromagnetic Environmental Effects Standards Committee, 2 March 2001.
4. **GEVS-SE REV A**, General Environmental Verification Specification for STS and ELV Payloads, Subsystems, and Components, NASA/GSFC, June 1996. (OBSOLETE)
5. **MIL-B-5087B(ASG)**, Bonding, Electrical, and Lightning Protection, for Aerospace Systems, Military Specification, 15 October 1964, plus all applicable amendments, up to and including Interim Amendment 3 (USAF), 24 December 1984. (CANCELLED)
6. **MIL-E-6051D**, Electromagnetic Compatibility Requirements, Systems, Department of Defense, 7 September 1967. (CANCELLED)
7. **MIL-HDBK-237**, Electromagnetic Environmental Effects and Spectrum Certification Guidance for the Acquisition Process, Department of Defense Handbook.
8. **MIL-HDBK-241**, Design Guide for EMI Reduction in Power Supplies, Naval Electronic Systems Command.
9. **MIL-HDBK-704-1**, Guidance for Test Procedures for Demonstration of Utilization Equipment Compliance to Aircraft Electrical Power Characteristics (Part 1 of 8 Parts), (latest version 9 April 2004).
10. **MIL-HDBK-704-7**, Guidance for Test Procedures for Demonstration of Utilization Equipment Compliance to Aircraft Electrical Power Characteristics 270 VDC (Part 7 of 8 Parts), (latest version 9 April 2004).
11. **MIL-HDBK-704-8**, Guidance for Test Procedures for Demonstration of Utilization Equipment Compliance to Aircraft Electrical Power Characteristics 28 VDC (Part 8 of 8 Parts), (latest version 9 April 2004).
12. **MIL-STD-461C**, Electromagnetic Emission and Susceptibility Requirements for the Control of Electromagnetic Interference, Department of Defense, 4 August 1986. (CANCELLED, superseded by MIL-STD-461D, superseded by MIL-STD-461F)
13. **MIL-STD-462**, Electromagnetic Interference Characteristics, Measurement of, Department of Defense, 31 July 1967, plus all applicable notices, up to and including

Notice 6 (USAF), 15 October 1987. (CANCELLED, superseded by MIL-STD-462D, superseded by MIL-STD-461E, superseded by MIL-STD-461F)

14. **MIL-STD-704F**, Aircraft Electric Power Characteristics, 12 March 2004.
15. **MIL-STD-1541A**, Electromagnetic Compatibility Requirements for Space Systems, USAF, 30 December 1987.
16. **MIL-STD-1542B**, EMC and Grounding Requirements for Space System Facilities, USAF, (latest version 15 November 1991).
17. **MIL-STD-1809**, Space Environment for USAF Space Vehicles, USAF, 15 February 1991.
18. **MIL-STD-1818A**, Electromagnetic Effects Requirements for Systems, Department of Defense, 4 October 1993. (CANCELLED)
19. **Program Manager's Handbook, Electromagnetic Environmental Effects (E3)**, Department of the Navy, Air Systems Command, 25 August 1999.

2.3.2 Ordnance

1. **AIAA S-113-2005**, Criteria for Explosive Systems and Devices Used on Launch and Space Vehicles, American Institute of Aeronautics and Astronautics, 10 November 2005.
2. **JSC-28596A**, NASA Standard Initiator User's Guide, NASA/Johnson Space Center (JSC), 29 February 2000.
3. **MIL-STD-1576 (USAF)**, Electroexplosive Subsystem Safety Requirements and Test Methods for Space Systems, DoD, (latest version 31 July 1984).

2.3.3 Charging and Discharging Phenomena

1. **NASA PRACTICE NO. PT-TE-1415**, Power System Corona Testing, NASA/Lewis Research Center (LeRC), (no author, no date).
2. **NASA Technical Paper (TP) 2361**, Design Guidelines for Assessing and Controlling Spacecraft Charging Effects, C. K. Purvis *et al.*, NASA, 1984.
3. **NASA/TP-2003-21228**, Low Earth Orbit Spacecraft Charging Design Guidelines, D. C. Ferguson and G. B. Hillard, NASA/MSFC, February 2003.
4. **NASA SP-8111**, Assessment and Control of Electrostatic Charges, NASA, May 1974.

2.3.4 DC Magnetism

1. **NASA SP-8018**, Spacecraft Magnetic Torques, NASA, March 1969.
2. **NASA SP-8037**, Assessment and Control of Spacecraft Magnetic Fields, September 1970.
3. **Practice No. PD-EC-1104**, Monitoring Spacecraft Exposure to Magnetic Fields, NASA, 30 June 1995.

2.3.5 RF Environments

1. **Aerospace Report No. TOR-2005(1663)-3790**, Cape Canaveral Spaceport Radio Frequency Environment, November 2004.
2. **NASA Contractor Report (CR) 4776**, The On-Orbit Radio Frequency Environment, NASA/MSFC, May 1997.

2.3.6 Program Classification

1. **DOD-HDBK-343 (USAF)**, Design, Construction and Testing Requirements for One of a Kind Space Equipment, USAF, 1 February 1986.

2.4 Order of Precedence

In the event of a conflict between the text of this document and the Applicable Documents cited herein, the text of this document shall take precedence. This document specifically takes precedence over MIL-STD-1540E and MIL-STD-461 EMC requirements. In the event of a conflict between the text of this document and any program-specific contractual documents, including interface documents, the requirements of the contractual documents shall take precedence. Nothing in this document, however, shall supersede applicable laws and regulations, unless specific exemptions have been obtained.

3. ABBREVIATIONS, ACRONYMS AND DEFINITIONS

3.1 General. The terms used in this document are defined in Aerospace Report No. TR-2004(8583)-1 (proposed MIL-STD-1540E) and/or ANSI C63.14. In addition, the following terms are applicable specifically to this document.

3.2 Abbreviations and Acronyms

A - ampere

AIAA - American Institute of Aeronautics and Astronautics

Amps - amperes

BW - bandwidth

EED - electroexplosive device

EELV - Evolved Expendable Launch Vehicle

EES - electroexplosive subsystem

EMC - electromagnetic compatibility

EME - electromagnetic effects

EME - electromagnetic environment

EMI - electromagnetic interference

EMISM - electromagnetic Interference safety margin

EMP - electromagnetic pulse

EPS - Electrical Power Subsystem

ESD - electrostatic discharge

EUT - Equipment Under Test

EWR - Eastern and Western Ranges

GEVS - General Environmental Verification Specification

GFE – Government-furnished equipment

HPM - high power microwave

IAW - In accordance with

IEC - International Electrotechnical Commission

IR - current (I) multiplied by resistance (R)

LISN - line impedance stabilization network

LNA - low noise amplifier

LRU - line replaceable unit

LV - launch vehicle

ma, mA - milliampere

mohm - milliohm

MSFC - Marshall Space Flight Center (NASA)

NDI - non-developmental item

NA, N/A – not applicable or “do not care”

NTIA - National Telecommunication and Information Administration

o'scope - oscilloscope
para. - paragraph
PIM - passive intermodulation
PL - payload
pps - pulses per second
RF - radio frequency
RFP - Request for Proposal
rms, RMS - root mean square
SA - solar array
SAS - solar array simulator
SPG - Single Point Ground
STS - Space Transportation System (NASA space shuttle system)
SV - space vehicle
TBD - to be determined
TOR - Technical Operating Report (An Aerospace Corp. document)
TPD - Terminal Protection Device
us - microseconds
UUT - Unit Under Test
uV - microvolts
V - volts
XFMR - transformer

3.3 Definitions

Acceptance. Verification of requirements by testing all units, subsystems or systems, rather than sample testing. This includes flight equipment, and it commonly employs lower and/or fewer stress limits than qualification testing.

Bond. Any fixed union existing between two objects that results in electrical conductivity between the two objects.

Bulk charging. The collection of charged particles (primarily electrons and protons) within the volume of a material. Charges will migrate to the surface of the material at a rate depending on the material conductivity. (Bulk charging may lead to different voltage potentials and discharge within the material, between the material and equipment components, or between the material and the space environment. This discharge is called ESD. Bulk charging is primarily a risk during on-orbit operations.)

Bus. The part of a space vehicle which supports payloads. It includes the structure, power subsystem, attitude and control subsystem, propulsion subsystem, telemetry subsystem and communications subsystem.

Corona. An electrical discharge phenomenon which can occur in the presence of a voltage gradient through a gas as a result of accelerated ionization of that gas. This can especially be a problem for insulators employed in high voltage subsystems if the insulators have defects in them, such as small voids, fractures, separations, or delaminations. If these defects have trapped gases, the gases may be ionized and

accelerated, causing damage to the insulator. Gradually or catastrophically, this may interfere with communications links and/or result in local or widespread insulation breakdown, arcing, and considerable damage to, or failure of, equipment. (Paschen's curve is widely referenced with regard to the breakdown of gases due to a voltage gradient.)

Deep charging. Surface or bulk charging deep within a spacecraft.

Electrical power subsystem (EPS). The assemblage of hardware and software which generates, stores, controls and/or distributes electrical power to equipment which use it. On a space vehicle, the EPS consists of a power generation subsystem, an electrical storage subsystem, a power control subsystem and a power distribution subsystem.

Electroexplosive device (EED). Any electrically initiated explosive device within an electroexplosive subsystem which has an explosive or pyrotechnic output. Also called the first element (of a pyrotechnic or explosive train). Examples include exploding bridgewires, squibs, detonators, electrical matches, and electrical detonators. (MIL-STD-1576)

Electroexplosive subsystem. Hardware and software used to actuate, control, and monitor an electrically initiated ordnance/pyrotechnic function. All components from the part of the electrical power subsystem dedicated to ordnance (e.g., ordnance bus) to the EED, including power cabling, power filters and/or isolators, Arm/Disarm switches (firing control circuits), relays and all electrical wiring used to monitor, arm and fire ordnance functions, and Safe & Arm devices. (MIL-STD-1576)

Electromagnetic interference safety margin (EMISM). The ratio of electromagnetic susceptibility to interference for a unit interface, expressed in dB. For the purposes of this definition, and in determining an EMISM, interference is the worst-case combination (superposition) of possible emissions at the target interface, and susceptibility is the worst-case condition (most sensitive operational geometry, mode, state, configuration, point or frequency) of the target unit. The interface medium may be conducted or radiated. EMISMs are a quantitative measure of the degree of EMC of electrical subsystems and systems.

Electromagnetic pulse (EMP). A wide bandwidth transient electromagnetic field caused by a nuclear event.

Equipment. A generic term referring to various levels of hardware (with associated software) assemblages.

In this document, the term "equipment" usually refers to all units, subsystems and payloads which are procured separately by the procuring authority or prime contractor to be integrated into a vehicle or ground support segment. (Also see General Requirements, Section 4.)

Equipment under test (EUT). Equipment which is intended to be, is being, or has been subjected to a particular test or group of tests.

Essential equipment. Equipment which is essential for minimum controllability and commandability of the spacecraft.

Flight vehicle. (Often called the space segment.) The combination of integrated elements of the launch system that is flown, i.e., the launch vehicle(s), the upper-stage vehicle(s), and the space vehicle(s).

Grounding. The bonding of an equipment case, frame, or chassis to an object or vehicle structure to ensure a common potential. Also, the connection of an electric circuit or equipment to earth or to some conducting body of relatively large extent which serves in place of earth.

High power microwave (HPM). An offensive RF weapon designed to upset or damage systems.

IR loss. Loss in operational voltage from the power source to the unit due to voltage drop in the cables from the source to the unit.

Launch vehicle. A lower stage of a flight vehicle whose function is to support placement of a space vehicles into an orbital trajectory. A fairing and fairing adapter(s) to protect the space vehicle during the boost phase are typically considered part of the launch vehicle.

Lightning direct effects. Any physical damage to a system structure and equipment due to the direct attachment of the lightning channel. These effects include tearing, bending, burning, vaporization, or blasting of hardware.

Lightning indirect effects. Electrical transients induced by lightning in electrical circuits due to coupling of electromagnetic fields.

Line impedance stabilization network (LISN). An electrical circuit placed between a power supply and equipment being tested (EUT) which is receiving the power, for conducted emissions and susceptibility tests. The purpose is two-fold. The first purpose is to standardize the test method. The second purpose is to emulate a worst-case bus impedance to the EUT, so that the EUT response measured will reflect its worst-case response if manifested on a spacecraft employing a worst-case bus impedance.

Magnetospheric charging. The process of accumulating electrical charge from the plasma environment in the geomagnetosphere.

Mean operational voltage. See “Operational voltage, mean”.

Multipaction. A high-power radio frequency (RF) resonance effect that occurs in a high vacuum where an RF field accelerates free electrons resulting in collisions with surfaces creating secondary electrons that are accelerated resulting in more electrons and ultimately a major discharge and possible equipment damage.

Nominal operational voltage. See “Operational voltage, nominal”.

Non-developmental item(s) (NDI). Materiel available from sources with little or no development effort required by the Government or contractor. NDIs include:

1. Items obtained from domestic or foreign commercial marketplaces. (This is also called commercial or commercial off-the-shelf (COTS) equipment.)
2. Items identical to those already procured by Government agencies or their contractors to some EMI requirements. (Some of these items may be called Government-furnished equipment (GFE).)
3. Items already developed by foreign governments that are legally available.

Operational voltage, mean . The power bus operational voltage (and hence, the unit operational voltage, uncorrected for IR loss) equidistant from the minimum and maximum operational voltages. For example, for a power bus which is specified to

have a range of operational voltages from 22V to 36V, the mean operational voltage is $(22+36)/2 = 29V$. (Note that the nominal voltage for this example is usually designated as 28V.)

Operational voltage, nominal. A term used to identify the general value of a power bus operational voltage. For instance, through long usage, an unregulated spacecraft bus which operates over the range of 22volts to 36volts is identified as a “28volt” bus. For this example, 28volts has no actual operational significance, since the bus operates near the low end of the range during eclipse, and near the upper end of the range in the sun, operating at 28volts only incidentally, if at all. Another example is a regulated bus which operates from 51volts to 52volts, which would be identified as a “50volt” bus, even though 50V is outside its operational range.

Passive intermodulation. The creation of harmonics or intermodulation products from the incidence of RF energy on otherwise unpowered objects or incidental contact junctions due to those objects or junctions acting as non-linear electrical devices, even though no other electrical power is applied to them at the time the RF energy is incident.

Payload. A spacecraft-manifested subsystem which performs a function or functions not directly related to spacecraft basic operations or maintenance.

Platform. An integrated collection of hardware and software standing alone to perform a mission. Examples are satellites, launch vehicles, airplanes and ships.

Protoqual. Protoqualification. Verification of requirements by testing all units, subsystems or systems. This includes flight equipment, since it is usually applied to procurements of a severely limited number of items, often only one. This level of testing commonly employs lower and/or fewer stress limits than qualification testing.

Qualification. Verification of requirements by testing a sample of like units, subsystems or systems, rather than every item. This level of testing may not be applied to flight units and is the most stringent level of testing.

Radio frequency (RF) compatibility. A part of electromagnetic compatibility. The ability of the various antenna-connected RF receiver and transmitter subsystems contained within a system to function properly without performance degradation caused by antenna-to-antenna coupling between any two subsystems.

Receiver. Any equipment whose purpose is to detect and process electromagnetic energy through air or space.

Resistivity, surface. Resistance in ohms per square of a square of thin material, as measured between opposite edges.

Resistivity, volume. Resistance in ohm-centimeter of a one centimeter cube of material, measured between opposite faces.

Satellite. A complete free-flying vehicle in space, frequently orbiting the earth. Synonymous with spacecraft and space vehicle.

Solar wind. The flux of neutral and charged particles, also called a plasma, ejected from the sun's surface into and through interplanetary space.

Spacecraft (SC or S/C). A complete free-flying vehicle in space, frequently orbiting the earth. Synonymous with satellite and space vehicle.

Space vehicle (SV). A complete free-flying vehicle in space, frequently orbiting the earth. Synonymous with satellite and spacecraft.

Spike. A narrow, high amplitude pulse with a sharply defined maximum. May be recurring or non-recurring, periodic or aperiodic.

Static electricity. A concentration of stationary electrical charge.

Subsystem. An assemblage of functionally related units and their associated software, cabling and mounting structure. Examples are "attitude control system", "electrical power subsystem", "payload 1" and "payload 2".

Surface charging. The collection of charged particles (primarily electrons, protons and oxygen ions) on the surface of a material during ground processing, launch, orbit insertion and/or on-orbit operations. (Surface charging leads to different voltage potentials on materials, resulting in possible discharge between equipment components or between equipment and the space environment. This discharge is called ESD.)

System. A composite of equipment, subsystems, skills and techniques capable of performing or supporting an operational role. A complete system includes related facilities, equipment, subsystems, materials, services and personnel required for its operation to the degree that it can be considered self-sufficient within its operational or support environment.

Tailoring. The process by which the requirements of a standard are adapted (that is, modified, deleted, or supplemented) to the characteristics or operational requirements of the item under development. The tailoring process does not constitute a waiver or deviation.

Technical Operating Report (TOR). A report written and released by The Aerospace Corporation for external release.

Transient. See spike. May have a less well-defined shape than a spike, but is still a high amplitude pulse.

Triboelectric charging. The accumulation of electric charges by friction, including the friction of gases, typically during launch.

Unit. An assembly of hardware and, if applicable, software, which operates together to perform a specific set of functions and that is viewed as a complete and separate entity for purposes of manufacturing, maintenance, record keeping, requirements verification and, frequently, procurement. The current draft version of MIL-STD-1540E uses the term "unit" to describe this level of hardware. MIL-STD-461 versions and MIL-STD-1541A use the term "equipment" to describe this level of hardware. Other references to this level of hardware include "box" and "line replaceable unit". Units include such items as "transmitters", "receivers" and "power converters".

Unit under test (UUT). Same as equipment under test (EUT).

Vehicle. An airborne and/or space-borne assemblage of units and subsystems which operates together to launch space assets and/or provide payload support or mission support functions. Examples are "launch vehicle", "upper stage", "intermediate stage", "space vehicle", "spacecraft", "satellite" and "payload".

4. GENERAL REQUIREMENTS

4.1 Units and Subsystems

a. Purpose. The purpose of these general requirements is to reduce redundancy in the detailed requirements and to provide general tailoring of requirements.

b1. Applicability: Basic. Unit requirements apply to all units, to all payloads, and to all subsystems and systems which are procured separately by the procuring authority or prime contractor or major subcontractors and vendors to be integrated into a vehicle or ground support segment. This includes ordnance subsystems.

b2. Applicability: Power. Conducted emissions and susceptibility requirements on power leads and command/control lines apply only to DC power systems, unless otherwise indicated or specified.

c1. Requirement: General requirements of MIL-STD-461F. The general requirements of MIL-STD-461F (Chapter 4) shall be met, except as otherwise tailored or superseded by this document.

c2. Requirement: Non-developmental items (NDI). All NDI, regardless of the previous methods of verification or equipment application, shall meet the unit requirements of the program in which they will be used, or EMI requirements derived from the vehicle requirements of the program in which they will be used, including EMISMs.

c3. Requirement: Requirement matrix in MIL-STD-461F. The requirement matrix in MIL-STD-461F shall be superseded by Table 1.2.2-1 of this document.

c4. Requirement: Cables and loads. A unit shall include all cables intended to be used with the unit on its operational platform (flight or flight-like cables) and loads on those cables which emulate mission loads, except as otherwise specified in MIL-STD-461F or this document, which takes precedence over MIL-STD-461F. This includes units which are NDI.

c5. Requirement: Environments. Units shall meet all of the requirements of this document for all environments to which they may be exposed during their respective service lives. This includes assembly, test, storage, transportation, prelaunch, launch, on-orbit, stand-by and all operational environments. It also includes contributions to these environments from (generally low-level) unintentional electromagnetic emitters and from (possibly high-level) intentional friendly and hostile emitters.

c6. Requirement: Applicable interfaces. Applicable interfaces include all intentional and unintentional radiated and conducted interfaces between units and between units and internal and external environments. No conducted or radiated interface, intentional, unintentional or incidental, shall be exempt from EMC requirements.

c7. Requirement: Modes of operation. All requirements shall be met for every mode of operation of the unit or subsystem.

c8. Requirement: Operational voltages. Requirements shall apply over the entire bus operational voltage range. If the bus operational voltage range is not known, requirements shall apply over the entire unit operational voltage range.

c9. Requirement: RMS units of measurements. Unless otherwise specified, all frequency domain and time domain ripple limits are expressed in root mean square (rms) values. See MIL-STD-461F, paragraph 5.1.1, for details.

(P) c10. Requirement: Secondary power. Secondary power shall be subject to all of the power conducted interface requirements of this document, including EMISM and CS114, CS115 and CS116, if the power is serving multiple loads.

d1. Verification: General. Every requirement which is levied against equipment shall be verified in accordance with the associated verification methods given in this document.

(Note: Requirements are generally verified by testing (T), analysis (A), inspection (I), demonstration (D) or some combination, either at different phases in the procurement or at the same time (e.g., analysis using test data). If data or verification is based on "similarity," it is essential that the equipment and test procedures and methods and/or baseline conditions be nearly identical. Otherwise the applicability of "similarity" to the new procurement is defective and the results will likely be invalid. In addition, considerable effort may be needed to define similarities and differences and to evaluate the validity of the "similarity" for the particular purpose. In the discipline of EME, verification by test, and analysis based on test data, provide the most accurate verification results. In most cases, they are the only methods of obtaining accurate results.)

d2. Verification: Test methods of MIL-STD-461F. The test methods of MIL-STD-461F shall be used to verify the unit and subsystem requirements of this document, except as otherwise tailored or superseded by this document.

d3. Verification: Non-developmental items (NDI). All NDI, regardless of the previous methods of verification or equipment application, shall be verified to meet the unit requirements of the program in which they will be used, or EMI requirements derived from the vehicle requirements of the program in which they will be used, including EMISMs.

d4. Verification: Test-like-you-fly. To the extent practicable, and except as otherwise required by this document, all tests shall be performed with the EUT configured the same as for mission operations ("test-like-you-fly").

In addition, where necessary to fully verify all requirements, and to the extent practicable, sensors shall be tested in space-like environments.

d5. Verification: Cables and loads. All equipment requirements shall be verified with cables and loads as described in subrequirement c4.

(P) d6. Verification: Modes of operation. Subrequirement c7(modes of operation) may be met by a subset of all modes, where the subset exercises all EUT components and software as severely as all modes, if the subset is approved by the procuring authority.

d7. Verification: Operational voltage. Unless otherwise specified in an individual Requirement, verification shall be at the bus mean operational voltage as

defined in this document, corrected for IR loss from the bus source to the unit, if known. If the IR loss is not known, the bus mean operational voltage shall be used. If the bus mean operational voltage is not known, the unit mean operational voltage shall be used. Unless otherwise specified in an individual Requirement or otherwise specified by the procuring authority, it shall be assumed that verifying the Requirement at this one voltage satisfies subrequirement c8.

d8. Verification: Test signal modulation. Susceptibility test signals for Requirements 6.11(CS02), 6.27(RS103) and 6.30(CS114) shall have modulation characteristics (for example, amplitude, type, degree, frequency and waveform) which have the maximum effect on the unit or subsystem, as shown by analysis. If analysis does not demonstrate unit sensitivity to specific modulations, the standard modulation characteristics of MIL-STD-461F, paragraph 4.3.10.4.2, shall be used, and shall also be applied to Requirement 6.11(CS02).

d9. Verification: LISNs. Where the use of a LISN is required for verification, a 5uH LISN shall be used. The LISN shall have the following characteristics.

- (1) Shall be applicable to single lines.
- (2) Shall have the ports and ground referencing capabilities required by the MIL-STD-461F LISN.
- (3) Shall be useful up to at least 400MHz, with 1GHz preferable.
- (4) Shall have a 1uF to 10uF feed-through capacitor, with 10uF preferable, at the input power terminal.
- (5) Shall be commercially available.
- (6) Shall be accompanied by calibration documentation, including impedance versus frequency plots specific for each unit.

(Notes:

- (1) LISNs which meet the above characteristics are commercially available.*
- (2) 5uH LISNs are more characteristic of space power bus impedances than the MIL-STD-461F LISN.*
- (3) The upper frequency capability is for applicability to requirements having frequency ranges extended past the MIL-STD-461F ranges.*
- (4) The 1uF to 10uF feed-through capacitor at the input power terminal is primarily to aid in decoupling noise from the external power supply line, and secondarily to help detune parasitic inductance of the power-side large decoupling capacitor (paragraph d10).*
- (5) The use of commercially-available LISNs is to encourage standardization of LISNs for space EMC test purposes.*
- (6) Calibration documentation is to ensure that the LISN retains its specified impedance characteristics.*
- (7) Pulsed loads (such as pulsed RF transmitters) may be damaged by using a LISN with a series inductance higher than the inductance of the flight cable. This has happened using the MIL-STD-461F standard LISN.)*

d10. Verification: Test methods using LISNs, detuning capacitor and resistor.

For test methods using LISNs, the power supply side of the LISNs shall have a 100,000uF 20% low-inductance capacitor in series with a non-inductive 10mohm 10% resistor, the series combination of which shall be connected across the power supply sides of the LISNs (*i.e.*, between power and return), with minimum inductance wiring or bus bars. (See Figure 6.11d1-1 (Test Setup (CS02)) for a diagram.)

(Note: The use of a large capacitor and small resistor detunes the effects of the power source and line inductance, eliminating resonances which the EUT might otherwise experience.)

d11. Verification: Power referencing. For platform DC power architectures using single point grounding (SPG) and equipment chassis electrically bonded to platform structure, the power return line shall be grounded only at the test bench ground plane at the earliest possible point, such as the source side of the return line LISN at the detuning capacitor/resistor (paragraph d10). (See Figure 6.11d1-1 (Test Setup (CS02)) for a diagram.) Also, grounding at the power supply source shall be avoided.

d12. Verification: Cables from shielded enclosure power entry to LISNs. For test methods in a shielded enclosure, where the RF noise must be kept low, power cables shall be shielded twisted pairs.

d13. Verification: Electromagnetic ambient during radiated tests. In the vicinity of the equipment under test (EUT) and test detectors, the electromagnetic environment shall be lower than verification levels by 6dB for all verification frequencies. (This may require placing EUT exercising equipment and test equipment in a different enclosure than the detector(s) and EUT. Special test equipment which compensates for environmental RFI may be an option.)

d14. Verification: Test equipment sensitivities. Test equipment shall have sensitivities 6dB below verification levels.

d15. Verification: Ordnance. Each ordnance subsystem shall be tested as a stand-alone unit or as incorporated into a larger subsystem, e.g., a payload. The EED shall be replaced by an EED simulator for test purposes. Candidate simulators are optical simulators, electrical simulators (e.g., a sensing resistor voltage into an amplifier) and fuse simulators (fusing at 20dB below the EED no-fire level).

d16. Verification: Primary and redundant sides. Requirements shall be verified for both primary and redundant sides of equipment.

- (P) e1. Tailoring: Limits.** The limits of any Requirement shall be made more stringent if required for mission EMC. The limits may be made less stringent if it is adequately demonstrated that mission EMC will not be degraded, but only if approved by the procuring authority.
- (P) e2. Tailoring: Secondary power.** The limits of power interface requirements for secondary power shall be tailored in accordance with the emissions characteristics of the loads, the secondary bus parameters, and the resulting power quality of the secondary bus, but not the load robustness, as approved by the procuring authority.

4.2 Vehicle

a. Purpose. The purpose of these requirements is to reduce redundancy in the detailed requirements and to provide general tailoring of requirements.

b. Applicability. These requirements apply to all vehicles and spacecraft.

c1. Requirement: Applicable interfaces. Vehicle-level requirements shall apply to all interfaces of units of a procured system or subsystem. Applicable interfaces include all intentional and unintentional radiated and conducted interfaces between units and between units and external environments. NDIs and ordnance subsystems shall meet these requirements.

c2. Requirement: Segment and vehicle interfaces. All segment and vehicle interface requirements shall be met. These interfaces include, but are not limited to:

- (1) Space vehicle interfaces
- (2) Launch vehicle interfaces
- (3) Launch site interfaces
- (4) Payload interfaces
- (5) Ground support equipment interfaces
- (6) Test equipment interfaces
- (7) Ordnance interfaces
- (8) All other equipment interfaces

c3. Requirement: Exemption of interfaces. No conducted or radiated interface, intentional, unintentional or incidental, shall be exempt from EMC requirements.

c4. Requirement: Non-developmental items (NDI). All NDI, regardless of the previous methods of verification or equipment application, shall meet the vehicle requirements of this document.

c5. Requirement: Environments. Vehicles shall meet all of the requirements of this document for all environments to which they may be exposed during their respective service lives. This includes assembly, test, storage, transportation, prelaunch, launch, on-orbit, stand-by and all operational environments. It also includes contributions to these environments from (generally low-level) unintentional electromagnetic emitters and from (possibly high-level) intentional friendly and hostile emitters.

(P) c6. Requirement: Secondary power. Secondary power shall be subject to all of the power conducted interface requirements of this document, if the power is serving multiple loads.

d1. Verification: General. Every requirement which is levied against vehicles shall be verified in accordance with the associated verification methods given in this document.

d2. Verification: Test methods of MIL-STD-461F. The test methods of MIL-STD-461F shall be used to verify the vehicle requirements of this document (where appropriate), except as otherwise tailored or superseded by this document.

d3. Verification: Non-developmental items (NDI). All NDI, regardless of the previous methods of verification or equipment application, shall be verified to meet the vehicle requirements of the program in which they will be used, including EMISMs.

d4. Verification: Test-like-you-fly. To the extent practicable, and except as otherwise required by this document, all tests shall be performed with the vehicle configured the same as for mission operations (“test-like-you-fly”).

d5. Verification: Test signal modulation. Susceptibility test signals for Requirements 6.11(CS02), 6.27(RS103) and 6.30(CS114) shall have modulation characteristics (for example, amplitude, type, degree, frequency and waveform) which have the maximum effect on the unit or subsystem, as shown by analysis. If analysis does not demonstrate unit sensitivity to specific modulations, the standard modulation characteristics of MIL-STD-461F, paragraph 4.3.10.4.2, shall be used, and shall also be applied to Requirement 6.11(CS02).

d6. Verification: Electromagnetic ambient during radiated tests. In the vicinity of the vehicle under test and test detectors, the electromagnetic environment shall be lower than verification levels by 6dB for all verification frequencies. (This may require placing vehicle exercising equipment and test equipment in a different enclosure than the vehicle and detector(s). Special test equipment which compensates for environmental RFI may be an option.)

d7. Verification: Test equipment sensitivities. Test equipment shall have sensitivities 6dB below verification levels.

d8. Verification: Primary and redundant sides. Requirements shall be verified for both primary and redundant sides of equipment.

(P) e1. Tailoring: Limits. The limits of any Requirement shall be made more stringent if required for mission EMC. The limits may be made less stringent if it is adequately demonstrated that mission EMC will not be degraded, but only if approved by the procuring authority.

(P) e2. Tailoring: Secondary power. The limits of power interface requirements for secondary power shall be tailored in accordance with the power quality of the power line and the emissions characteristics of the loads, but not the load robustness, as approved by the procuring authority.

4.3 EMISMs

a. Purpose. The purpose of these requirements is to ensure the intrasystem and intersystem EMC of space systems over their entire service lives.

b. Applicability. This requirement applies to all equipment. This includes, but is not limited to, intrasystem conducted interfaces, intrasystem unintentional radiated interfaces, intrasystem intentional radiated interfaces (antenna-connected equipment), intersystem radiated interfaces (external RF environment) and EESs. General applicability is also provided in paragraphs 4.1b1, 4.1b2 and 4.2b.

c1. Requirement: Basic. All systems and subsystems shall have EMISMs as given in Table 4.3-1.

Table 4.3-1. EMI Safety Margins.

Equipment	Qualification Tests	Protoqual & Acceptance Tests	Analysis ¹
Equipment, subsystems and systems, the degraded performance of which could cause serious injury or loss of life, damage to property, or major loss or delay of mission capability	12dB	6dB	18dB
EED interfaces, RF level referenced to DC no-fire level ²	20dB ²	20dB ²	N/A
EED interfaces, RF level referenced to RF no-fire level ³	12dB	12dB	N/A
All other equipment, subsystems and systems	0dB	0dB	6dB

¹ *If verification uses data obtained analytically (instead of by test) for either emissions or susceptibility.*

² *MIL-STD-1576, para. 4.4.1a; JSC-28596A, para. 11.0a; AFSPCMAN 9-710 Vol. 3, para. 13.3.1.6; AIAA S-113-2005, paras. 5.3.4.2.4, 5.3.5.3, 5.3.5.4, 5.3.5.5.*

³ *When available.*

c2. Requirement: Receiver and transmitter passbands. Within receiver and transmitter LNA BWs and 3dB passbands, this Requirement applies to damage and overstress levels for external (off-platform) sources, and to any susceptibilities for co-site (on-platform) sources. (Also see subrequirements 6.27c6-c9(RS103, Antenna-connected equipment.)

d1. Verification: Basic. Verification shall be by test and analysis using data and analysis methods approved by the procuring activity. Test data shall include unit-level test data, system test data and other test data determined by the contractor and approved by the procuring activity. External environment values used for analyses shall envelop the limits in Requirement 6.27(RS103).

d2. Verification: Timing. Verification shall begin no later than PDR, using best data and conservative approximations of unavailable data. (Test data is not necessarily required at PDR.) As the program matures, verification shall be updated. Final margins verification shall be determined using vehicle test data.

e. Tailoring: Program classes. Class A and B programs (per DOD-HDBK-343 (USAF)) shall meet the full requirements. Class C and D programs may qualify at 6dB. Qualification below 6dB is not recommended. All programs shall meet the ordnance requirements.

4.4 Service Life

- a. Purpose.** The purpose of this requirement is to ensure that all requirements in this document are met for the entire service lives of all space system equipment.
- b. Applicability.** This requirement applies to all space system equipment which will be used in space or directly support space system operations.
- c. Requirement.** All requirements of this document shall be met for the entire service life (development to retirement) of the respective unit, subsystem, system or vehicle which will be used in space or directly support space system operations.
- d. Verification.** Verification shall be by analysis using methods approved by the procuring authority. Analysis shall consider, as a minimum, components affected by space environments, time and electrical stress.

5. DETAILED REQUIREMENTS, GROUND UNITS AND SUBSYSTEMS

5.1 Ground Support Equipment

- a. Purpose.** The purpose of this set of requirements is to ensure that units and subsystems will operate compatibly with other equipment and the electromagnetic environment when integrated into a subsystem or system operating on the ground in support of space systems.
- b. Applicability.** This set of requirements applies to equipment per applicability and tailoring given in MIL-STD-461F, for equipment and subsystems which will be used in ground fixed and mobile facilities to support launch, flight support and space operations. (It is not generally applicable to such equipment as special test equipment or training equipment.)
- c. Requirement.** Equipment shall meet the requirements of MIL-STD-461F. Also see Requirement 4.1(General Requirements, Units and Subsystems).
- d. Verification.** Verification shall be by test IAW MIL-STD-461F. Also see Requirement 4.1(General Requirements, Units and Subsystems).
- (P) e. Tailoring: RFI environments.** As specified by the procuring authority, the MIL-STD-461F RS103 limits may be increased in accordance with special needs of the program. Table 5.1e-1 contains the requirements of MIL-STD-464A for guidance.

Table 5.1e-1. MIL-STD-464A RFI Requirements for Ground Equipment.*

Frequency Range	Electric Field (V/m - rms)	
	Peak	Average
10 kHz - 1.99 MHz	25	25
2 - 249 MHz	50	50
250 - 999 MHz	1500	50
1 - 9.99 GHz	2500	50
10 - 40 GHz	1500	50

* Limits from MIL-STD-464A, Table 1D, External EME for Ground Systems.

6. DETAILED REQUIREMENTS, SPACE AND LAUNCH UNITS AND SUBSYSTEMS

POWER LINE CONDUCTED EMISSIONS, SPACE EQUIPMENT

6.01 Conducted Emissions, Power and Command/Control Lines, 30Hz-50MHz (CE101/102A)

a. Purpose. The purpose of this requirement is to ensure that all equipment will operate compatibly when connected to the same external power source.

b. Applicability. This requirement applies to the external power leads and command/control lines driven directly by external power, including returns and grounds and neutrals not grounded internally to the equipment, of equipment which will be connected to an external power source, for equipment (units and subsystems) which will operate on a launch vehicle or in space.

c1. Requirement: Basic, 30Hz-50MHz. Units and subsystems shall meet the requirements of MIL-STD-461F, Figure CE101-4, Curve #2, except that the limits shall be extended from 10kHz/80dBuA in a straight line to 500kHz/26dBuA, and shall remain at 26dBuA to 50MHz. (See Figure 6.01c1-1.)

(Note that this Requirement specifies the 461 higher frequency limits in current (per 461C) rather than voltage (per 461F). Also see Notes 1 and 2 below.)

(P) c2. Requirement: Frequency range extension 0.1Hz-30Hz. If specified by the procuring authority, the required frequency range shall be extended down to 0.1Hz in accordance with special needs of the program. The limit shall be the same as that at 30Hz unless otherwise specified by the procuring authority.

(P) c3. Requirement: Frequency range extension 50MHz-400MHz. If specified by the procuring authority, the required frequency range shall be extended up to 400MHz in accordance with special needs of the program. The limit shall be the same as that at 50MHz unless otherwise specified by the procuring authority.

(P) c4. Requirement: Frequency range extension 50MHz-1GHz. If specified by the procuring authority, the required frequency range shall be extended up to 1GHz in accordance with special needs of the program. The limit shall be the same as that at 50MHz unless otherwise specified by the procuring authority.

d1. Verification: Basic, 30Hz-50MHz. Verification shall be by test IAW MIL-STD-461F as modified by paragraphs 6.01c1 to c4, 6.01d2 to d3 and 6.01e1 and e2, inclusive, and Requirement 4.1 (General Requirements, Units and Subsystems). Emissions shall be measured in current over the entire frequency range, and measurement equipment shall include a current probe or probes and other instrumentation calibrated over the entire frequency range.

(X) d2. Verification: Frequency range extensions. If the extended frequency range requirements of paragraphs c2, c3 and/or c4 are specified by the procuring authority, verification in the relevant frequency ranges shall be by test using test methods and test equipment approved by the procuring authority.

(P) d3. Verification: Operational voltages, minimum and maximum. If the percent variation between the maximum steady-state bus operating voltage and the minimum steady-state bus operating voltage is greater than 10%, testing shall be at the two voltage extremes as well as the mean. Alternatively, testing may be

specified to be performed at the expected bus eclipse operational voltage and the expected sun operational voltage. (Percent variation is the difference of two values, divided by their average, times 100.)

e1. Tailoring: Pulse loads. Special limits and/or bus design measures may be necessary to control bus ripple due to pulse loads, especially those with high current pulses. (Also see the second paragraph of Note 1.)

e2. Tailoring: High frequency limits. More-stringent limits may be required if the spacecraft will manifest sensitive receivers below 1GHz. (Also see Note 4.)

Figure 6.01c1-1. Limit Curve, CE101/102A

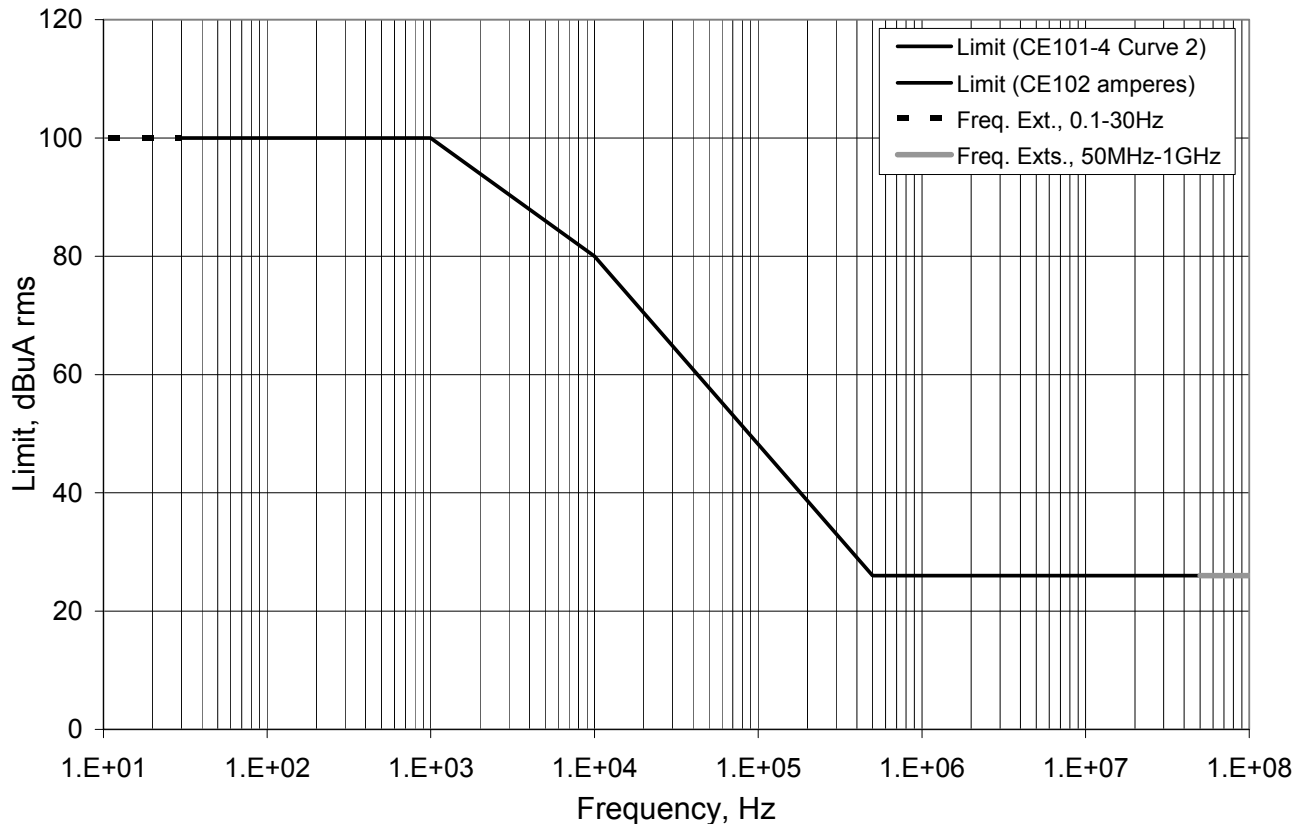

(Notes:

(1) MIL-STD-461F has CE101 limits for ships, submarines and aircraft. Since aircraft represent the closest type platform to spacecraft, those limits were used as a basis for this Requirement. Of the two limit lines given for aircraft, a higher one is for busses above 28V, and a lower one is for busses of 28V and below. On aircraft, low emission (quiet) loads are usually placed on the 28V bus, and noisy loads are placed on higher-voltage busses. However, spacecraft typically have only one bus for all loads, so it must be kept relatively quiet to avoid design and weight penalties on all loads, and hence, the spacecraft.

(In addition, there is only so much ripple allowed on the bus, which must be allocated to the power source, low power loads, high power loads and pulse loads (e.g., cryocoolers, pulsed radars and stepping motors). Of these, high current pulse loads represent the greatest challenge, since their "ripple" is the most difficult

to control. Using the lowest 461F standard emissions limit is expected to restrain most equipment on the bus from consuming more than a small percentage of the total bus ripple, even when their ripple is combined, leaving the greatest possible allocation of bus ripple to the pulse loads. (A quantitative definition of pulse loads is elusive; it needs to factor in the amount of current variation, the frequency of the pulses (their frequency component content), and whether they are defined before or after filtering by the unit EMI filters.)

(It is for the above reasons that the lower 461F curve was chosen.

(Consideration was also given to lowering the limits for low-power loads, but such an adjustment would complicate the Requirement, place a design burden on small loads, and probably not significantly reduce ripple.

(2) To accommodate heritage practice and aid in power supply design, the higher-frequency (CE102) units of measurement have been changed back to current (461C/CE03 units were amperes, 461F/CE102 units are volts), by taking the 461F CE102 voltage limits and dividing them by the corresponding 461F LISN impedance values, on a frequency-by-frequency basis. (Also see Note 3.) Furthermore, for ease in specification and testing, the requirements of CE101 and CE102 have been combined into one requirement (the "A" in the "CE101/102A" of the Requirement title stands for "amperes", versus the voltage limits of MIL-STD-461F).

(3) The current limits above 10kHz (the region of CE102) were obtained by taking the 461F CE102 voltage limits and dividing them by the corresponding 461F LISN impedance values, on a frequency-by-frequency basis. These values were plotted, yielding a very close match to the straight line presented in the Requirement limits. Hence, the current limits of this Requirement are consistent with the voltage limits of MIL-STD-461F.

(At the highest frequencies, the limits are a 6dB relaxation of the MIL-STD-461C limits (26dBuA versus 20dBuA). This is not expected to be a problem, but see Note 4.

(4) MIL-STD-461 explains in its appendix that the 60dBuV limit for frequencies above 500kHz was chosen because it is expected to result in radiated emissions (RE102) of 20dBuV/m, 4dBuV/m lower than the lowest RE102 requirement. The limit of 26dBuA/m used in this Requirement should give the same radiated emissions above 500kHz as the 461F limit (or lower), as long as the power line impedance is 50ohms (or lower). However, if the power line impedance is higher, the emissions are expected to increase in the ratio of 1dBuV/m per 1dBohm. (For example, a doubling of the line impedance from 50ohms to 100ohms would result in a radiated emissions increase from 20dBuV/m to 26dBuV/m.) This would not be a problem for most platforms, but if a platform manifests a receiver which is sensitive at or below 26dBuV/m (for example), within the frequency range of 500kHz to the upper frequency range of the Requirement, the Requirement limits may have to be lowered and/or the power lines redesigned.

(5) As guidance for the need for testing at the minimum and maximum bus voltages, consider that low frequency emissions are generally load induced due to power needs, and are therefore usually worst at the lowest bus voltage. On the other hand, high frequency noise is usually generated by power switching

transitions, which are greater at higher bus voltages. So in comparing the noise measured at the lower or higher bus voltages versus the mean, it can be expected to be somewhat inversely proportional or proportional to bus voltage, the greater the bus voltage variation, the greater the noise variation from the mean value. For example, for a bus with a mean voltage of V_0 and an operational range of $V_0 \pm 20\%$, the noise could be higher by 20% (about 2dB), at the voltage extremes. Therefore, if there is a program concern that testing at mean-only for a bus with a wide operational voltage range may be insufficient, it is possible to somewhat offset this concern by testing at mean-only, but lowering the limits to compensate for the possibly larger emissions at the lower and higher bus voltages (in the above example, about 2dB). Of course, equipment does not always behave as expected.

(6) The high frequency limit may be extended to 400MHz or 1GHz, if specified by the procuring authority, to control high-frequency conducted emissions via the power line to other loads, and/or to control cable radiated emissions in sensitive receiver bands at those frequencies.

6.02 (Reserved)

(P) 6.03 Conducted Emissions, Common Mode to Structure, Frequency Domain, 30Hz-50MHz

a. Purpose. The purpose of this requirement is to limit common mode emissions that flow through the vehicle structure and flight harness which may interfere with the operation of sensitive equipment referenced to the vehicle structure or equipment sensitive to magnetic fields generated by current loops.

b. Applicability. This requirement applies to equipment which will be connected to one or more external power sources, either for power or control, for equipment (units and subsystems) which will operate on a launch vehicle or in space.

c1. Requirement: Basic, 30Hz-50MHz. Units shall not exceed the limits given in Figure 6.03c1-1.

(P) c2. Requirement: Frequency range extension 0.1Hz-30Hz. If specified by the procuring authority, the required frequency range shall be extended down to 0.1Hz in accordance with special needs of the program. The limit shall be the same as that at 30Hz.

(P) c3. Requirement: Frequency range extension 50MHz-400MHz. If specified by the procuring authority, the required frequency range shall be extended up to 400MHz in accordance with special needs of the program. The limit shall be the same as that at 50MHz.

d1. Verification: Basic, 30Hz-50MHz. Verification shall be by test IAW MIL-STD-461F, CE101 and CE102, except that the test method shall be modified as follows:

The UUT (EUT) equipment enclosure shall be isolated from the ground plane by 5cm of non-conductive low relative permittivity material (or air), resulting in DC isolation of at least 10Mohm. A conductive wire or strap 5cm long shall electrically connect the equipment enclosure to the ground plane with bonds less than or equal to 2.5mohm. The measurement receiver current probe shall be placed around the 5cm conductor, and the current shall be measured with test equipment calibrated over the specified frequency range.

d2. Verification: Alternative method. The UUT shall be mounted to the test bench as configured for flight, the measurement receiver current probe shall be placed around all cables interfacing to the test unit simultaneously, and the current shall be measured with test equipment calibrated over the specified frequency range.

(X) d3. Verification: Frequency range extensions. If the extended frequency range requirements of paragraphs c2 and/or c3 are specified by the procuring authority, verification in the relevant frequency ranges shall be by test using test methods and test equipment approved by the procuring authority.

(P) e. Tailoring: Exemptions. Units which will be used on a vehicle whose design does not use isolated power/single point grounding/paired power and return leads (e.g., a vehicle which intentionally returns power on the vehicle structure) may be considered for an exemption from this requirement, based on mission EMC needs, but only if approved by the procuring authority.

Figure 6.03c1-1. Common Mode Conducted Emissions, Frequency Domain

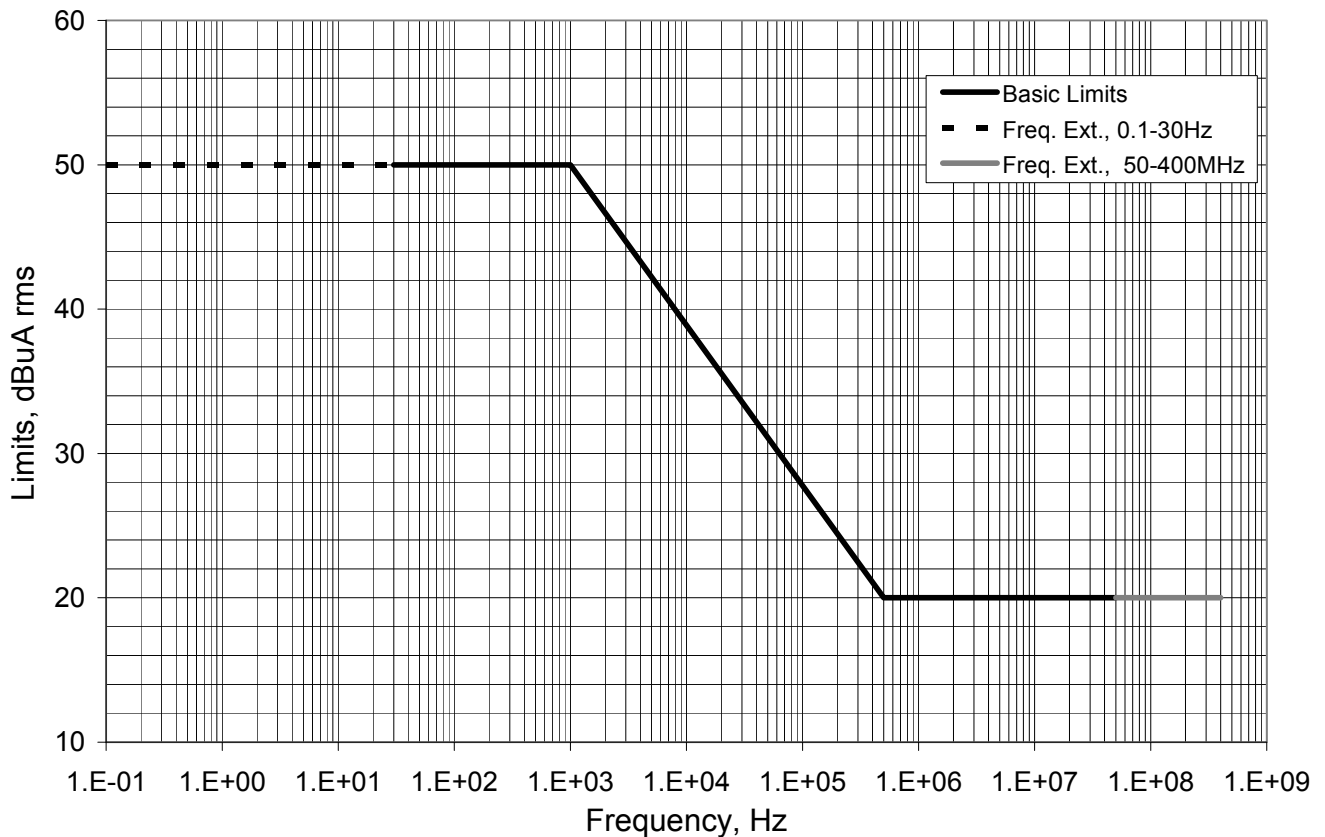

(Notes.

(1) This requirement encourages good primary and secondary common mode filter design, to keep common mode currents off of structure where they can interfere with sensitive equipment referenced to structure. This requirement also helps control low-level e-field and h-field radiated emissions.

(2) *The Requirement is adapted from NASA's GEVS-SE REV A, paragraph 2.5.2.1b and Figure 2.5-1a.*

(3) *The limits may be extended down to 0.1Hz to detect low frequency emissions which may particularly interfere with magnetics instruments or other low-frequency sensitive equipment, and may be extended up to 400MHz to protect against interference with equipment sensitive to high-frequency noise on the structure.*

(4) *When conductively isolating the UUT from the ground plane, thermal issues must be considered.*

(5) *Verification at the minimum and/or maximum bus voltages was not included for this Requirement because this Requirement was derived from a requirement which did not require it. However, if it is to be considered by the procuring authority or for future versions of this document, consider Note 5 at the end of Requirement 6.01(CE101/102A). The primary difference between the situation analyzed in that note and this discussion, is that because of the common mode leakage path to ground through an equivalent impedance, emissions at both low frequencies and high frequencies should be greater at higher voltages, and hence the worst case should be at the maximum operating voltage. Once again, equipment does not always behave as expected, and this situation is more complicated than the previous one.)*

(P) 6.04 Conducted Emissions, Common Mode to Structure, Time Domain

a. Purpose. The purpose of this requirement is to limit common mode emissions that flow through the vehicle structure and flight harness which may interfere with the operation of sensitive equipment referenced to the vehicle structure or equipment sensitive to magnetic fields generated by current loops.

b. Applicability. This requirement applies to equipment which will be connected to one or more external power sources, either for power or control, for equipment (units and subsystems) which will operate on a launch vehicle or in space.

c. Requirement. *(The current limits for this requirement will be included in a future version of this document or will be provided by the procuring authority.)*

d. Verification. Verification shall be by test using the test method of Paragraph 6.03d1 or 6.03d2, and the measurement equipment shall be capable of measuring and recording graphical data in the time domain from DC to 400MHz.

(P) e. Tailoring: Exemptions. Units which will be used on a vehicle whose design does not use isolated power/single point grounding/paired power and return leads (e.g., a vehicle which intentionally returns power on the vehicle structure) may be considered for an exemption from this requirement, based on mission EMC needs, but only if approved by the procuring authority.

(Note: This requirement is the time domain companion to Requirement 6.03. It gives the "ripple" of common mode currents on structure, and may be used to calculate the maximum voltage ripple on structure.)

6.05 (Reserved)

6.06 Conducted Emissions, Ripple and Periodic Transients, Power and Command/Control Lines

a. Purpose. The purpose of this requirement is to ensure that equipment will not place ripple and periodic transients due to normal operations on a power bus which, when combined with the emissions from other equipment on the bus, may interfere with equipment on the bus.

b. Applicability. This requirement applies to the external power leads and command/control lines driven directly by external power, including returns and grounds and neutrals not grounded internally to the equipment, of equipment which will be connected to an external power source, for equipment (units and subsystems) which will operate on a launch vehicle or in space.

c1. Requirement: Low BW ripple. Under normal operating conditions, the unit shall not generate low BW (DC-1MHz) ripple, including periodic transients, in excess of 0.1% of the mean bus voltage, as measured peak-to-peak in the time domain. (For example, for a 28V bus with a mean operational voltage of 29V, the maximum peak-to-peak value of low BW ripple would be $29V \times 0.001 = 29mV_{p-p}$.)

(P) c2. Requirement: High BW ripple. Under normal operating conditions, the unit shall not generate high BW (DC to at least 400MHz) ripple, including periodic transients, in excess of 0.35% of the mean bus voltage, as measured peak-to-peak in the time domain. (For example, for a 28V bus with a mean operational voltage of 29V, the maximum peak-to-peak value of low BW ripple would be $29V \times 0.035 = 102mV_{p-p}$.)

d1. Verification: Basic. Verification shall be by test, using a test method approved by the procuring authority. The test method of MIL-STD-461F, CE102, may be used as guidance, but the measurement receiver shall display in the time domain and shall have a minimum BW of 1MHz for low BW ripple measurements and a minimum BW of 400MHz for high BW ripple measurements (if specified). If necessary for adequate measurement resolution, ripple measurement instruments shall include a very low frequency DC block. Also see Requirement 4.1 (General Requirements, Units and Subsystems).

d2. Verification: Operational voltages and modes. Verification shall be at the mean operational voltage of the unit (as defined in this document) for each operational mode.

(P) d3. Verification: Operational voltages, minimum and maximum. If the percent variation between the maximum steady-state bus operating voltage and the minimum steady-state bus operating voltage is greater than 10%, testing shall be required at the two voltage extremes as well as the mean. Alternatively, testing may be specified to be performed only at the expected eclipse bus operational voltage and the expected sun operational voltage. (Percent variation is the difference of two values, divided by their average, times 100.) *(Also, see Note 10.)*

e. Tailoring: Pulse loads. Special limits and/or bus design measures may be necessary to control bus ripple due to pulse loads, especially those with high current pulses. *(Also see Note 3 below and Requirement 6.01, Note 1, second paragraph.)*

(Notes:

(1) This requirement addresses normal ripple and periodic transients produced by equipment. Requirement 6.07(CE07) addresses short-duration aperiodic transients.

(2) A low BW (1MHz) unit ripple is the basic requirement, because

(A) Higher frequency components of unit-generated ripple may not couple through the bus and other load filters at levels sufficient to affect bus loads,

(B) Frequency domain conducted emissions and susceptibility requirements are expected to control EMC for the higher-frequency components of ripple, and

(C) High frequency components of ripple make it difficult to measure the basic (lower frequency) ripple.

(A high BW (400MHz) unit ripple requirement is included because there may be situations where a high fidelity determination of unit ripple is required or desirable.

(This dual layer approach to ripple was chosen, since an industry-wide definition of ripple and agreement on the frequency range over which it should be measured is elusive.

(3) The low BW (basic) limits provide considerable margin with respect to complementary requirements in Aerospace Report No. TOR-2005(8583)-2 and AIAA Standard S-122-2007 (2.8% of the allowed non-deadband ripple in the latter, or 31dB). The large margin allows more ripple to be allocated to pulse loads, as discussed in Requirement 6.01, Note 1, second paragraph.

(As an example, assume a "28V bus" with a mean bus and unit operational voltage of 29volts. Non-pulse and other non-exempt loads would be required to have ripple under $0.001 \times 29V = 29mV_{p-p}$ of ripple. If there were only 25 such non-correlated loads on the bus, the ripple would combine in rms combination to be $5 \times 29mV = 145mV$, or 14.5% of the allocatable ripple. This would leave 85.5% of the ripple allocation to pulse loads and the source, excluding any dead band.

(The high BW limits are relaxed from the low BW limits, allowing an extra 11dB (3.5x) increase in ripple due to the high frequency ripple components, while still leaving 20dB of margin with respect to the requirements of AIAA Standard S-122-2007. Setting the high BW limit at 3.5 times the low BW ripple also helps avoid failures except in extreme cases, but it is not too high to generate excessive bus ripple in combination with other bus loads.

(4) The purpose of this requirement is to predict the level of voltage emissions that the unit will generate on the actual spacecraft bus when integrated into the vehicle. Therefore, the impedance into which the emissions are driven is critical.

(5) This requirement is more stringent than the MIL-STD-1541A requirement for total bus ripple plus repetitive spikes, which is 500mVp-p, since this Requirement is based on a different power quality standard and allows allocation to pulse sources.

(6) This requirement is more stringent than the GEVS-SE REV A requirement that the ripple following a normal operational transient may not exceed $\pm 0.45V_{pk}$ (0.9Vp-p) for units on a 28V bus.

(7) *This requirement is more stringent than the capabilities of some space equipment designed to operate on 28V buses (~1Vp-p), based on proprietary test data.*

(8) *The MIL-STD-704 maximum ripple for a 28VDC system is 1.5Vpk, which is 6x higher than the MIL-STD-1541A level. Furthermore, in the frequency domain, the MIL-STD-704 maximum distortion level for a 28VDC system is 1Vrms (1.4Vpk for a sine wave) from 1-5kHz, which is almost 6x higher than MIL-STD-1541A. These large differences are partly due to the generalism that aircraft buses are noisier than spacecraft buses.*

(9) *An oscilloscope BW of 400MHz is required for a high fidelity ripple measurement, and a very low frequency DC block is required to ensure that very low frequency components are included in the measurement.*

(10) *The time domain ripple of a unit may be viewed as an integration of sorts of all the frequency domain current emissions driven through the impedance values of the power bus at those respective frequencies. Typically, lower frequency current emissions are greater than high frequency emissions, but lower frequency bus impedances are lower than high frequency bus impedances. So there does not appear to be a simple answer as to whether ripple would be higher at the maximum, minimum or mean bus voltage. The default is therefore to test at the mean operational voltage, unless a particular unit or type of equipment is known to generate greater ripple at some other operational voltage. Testing at the expected eclipse and sun bus operational voltage levels is a meaningful alternative.)*

6.07 Conducted Emissions, Short-Duration Aperiodic Transients, Power and Command/Control Lines (CE07)

a. Purpose. The purpose of this requirement is to ensure that equipment will not place transients of $\leq 50\mu\text{s}$ duration, periodic and aperiodic, on a power bus which may interfere with equipment on the bus.

b. Applicability. This requirement applies to the external power leads and command/control lines driven directly by external power, including returns and grounds and neutrals not grounded internally to the equipment, of equipment which will be connected to an external power source, for equipment (units and subsystems) which will operate on a launch vehicle or in space.

c. Requirement. The unit shall not generate transients of $\leq 50\mu\text{s}$ pulse width, whose peak voltage is greater than +12.5V or less than -6.25V, and having respective impulse strengths greater than 62.5 $\mu\text{V}\cdot\text{sec}$ or 31.3 $\mu\text{V}\cdot\text{sec}$.

d1. Verification: Basic. Verification shall be by test, using a test method approved by the procuring authority. The test method of MIL-STD-461F, CE102, may be used as guidance, but the measurement receiver shall display in the time domain and have a minimum BW of 400MHz. Also see Requirement 4.1 (General Requirements, Units and Subsystems).

d2. Verification: Operational voltages and modes. Verification shall be at the mean operational voltage of the unit (as defined in this document) for each operational mode.

d3. Verification: Modes and transitions. The unit shall be tested in all modes of operation and transitioning between modes if that may happen during vehicle operations.

(Notes:

(1) The limits are more stringent than previous standards in order to provide margin with a complementary requirement in Aerospace Report No. TOR-2005(8583)-2.

(2) The purpose of this requirement is to predict the level of voltage emissions that the unit will generate on the actual spacecraft bus when integrated into the vehicle. Therefore, the impedance into which the emissions are driven is critical.

(3) An oscilloscope BW of 400MHz is required for a high fidelity transient measurement.)

6.08 Conducted Emissions, Inrush Current, Power and Command/Control Lines

a. Purpose. The purpose of this requirement is to ensure that equipment will not overstress fuses or adversely affect the power bus as a result of inrush current due to changes in bus voltage as a result of normal equipment operations.

b. Applicability. This requirement applies to the external power leads and command/control lines driven directly by external power, including returns and grounds and neutrals not grounded internally to the equipment, of equipment which will be connected to an external power source, for equipment (units and subsystems) which will operate on a launch vehicle or in space.

c1. Requirement: Inrush current, initial power application. Initial application of power to the unit shall not result in a unit input peak inrush current greater than four times the unit maximum steady-state operational current nor a unit input current rate of change (di/dt) greater than 50mA/us. In addition, the unit input current shall return to within 10% of the unit steady-state operational current within 50ms of initial application of power to the unit.

c2. Requirement: Inrush current, normal operations. During normal unit operations, including converter turn-on, converter load turn-on, converter and load simultaneous turn-on, load mode changes and load cycling, the unit peak input current shall not exceed 150% of the unit maximum operational current for any input voltage within the specified operational voltage range of the unit. In addition, the unit input current rate of change (di/dt) shall not exceed 50mA/us.

d1. Verification: Basic. Verification shall be by test in accordance with methods and procedures approved by the procuring authority.

d2. Verification: Unit operational voltage, initial power application. For subrequirement c1, the input voltage shall rise from 0V to the unit maximum steady-state operational voltage.

d3. Verification: Unit operational voltage, normal operations. Subrequirement c2 shall be verified at the unit maximum steady-state operational voltage.

d4. Verification: Test equipment capabilities. The test power source shall be capable of driving adequate current into the unit fast enough to avoid limiting the

response of the unit. Switching employed to apply power to the unit shall not bounce or arc.

(P) e1. Tailoring: Soft start. Units which may be damaged by powering up from a cold start may employ different limits and test methods, as approved by the procuring authority. The limits should be at least as stringent as the expected soft start characteristics for the operational environment.

e2. Tailoring: Very high currents. Units with very high steady-state operational currents may need to have the inrush current limit reduced to protect the bus from adverse affects.

(Notes:

(1) In most cases, a maximum current transient of four times the steady-state operational current should be insufficient to overstress load fuses if properly selected, and should be insufficient to otherwise adversely affect the bus if designed carefully.)

(2) Outrush current requirements, verification methods and tailoring are given in paragraphs 6.14c5, 6.14d2 and 6.14e, respectively.)

6.09 (Reserved)

POWER LINE CONDUCTED SUSCEPTIBILITY, SPACE EQUIPMENT

6.10 Conducted Susceptibility, Power and Command/Control Lines, 30Hz to 150kHz (CS101)

a. Purpose. The purpose of this requirement is to ensure that all equipment will operate compatibly when connected to the same external power source.

b. Applicability. This requirement applies to the external power leads and command/control lines driven directly by external power, including returns and grounds and neutrals not grounded internally to the equipment, of equipment which will be connected to an external power source, for equipment (units and subsystems) which will operate on a launch vehicle or in space.

c1. Requirement: Basic, voltage. Units shall meet the requirements of MIL-STD-461F as modified by this document. The rms limit from 30Hz to 5kHz shall be 126dBuV (2V) for units on busses with mean operational voltages of 36V and lower, 136dBuV (6.3V) for units on busses with mean operational voltages of 95V and higher, and 6.3% of the mean bus operational voltage (as defined in this document) for units on busses with mean operational voltages between 36V and 95V. See Figure 6.10c1-1. *(Example: For a mean bus voltage of 50V, unless otherwise restricted, the limit for units attached to this bus, from 30Hz to 5kHz, is $0.063 \times 50V = 3.15V_{rms} = 130dBuV_{rms}$, or $8.9V_{p-p}$.*

The limit at 150kHz shall be 1V_{rms}, and the limits between 5kHz and 150kHz shall be determined by a straight line between the limit at 5kHz and the limit at 150kHz. (See Figure 6.10c1-1.)

c2. Requirement: Basic, power. The limit requirements of this Requirement are also met when the power source is adjusted to dissipate the power level shown in

Figure 6.10c2-1 into a 0.5ohm load, and the unit is not susceptible, as defined by MIL-STD-461.

(P) c3. Requirement: Frequency range extension 0.1Hz-30Hz. If specified by the procuring authority, the required frequency range shall be extended down to 0.1Hz in accordance with special needs of the program. The limit shall be the same as that at 30Hz.

c4. Requirement: Exceeding operational voltage range. In some cases, the limits required in subrequirement c1 from 30Hz to 5kHz may result in exceeding the operational range of the unit by too great a value (more than +/- 5% of the mean bus operational voltage beyond the unit maximum or minimum operational voltages, respectively.). In these cases, the limit may be tailored to a value such that when the required signal is imposed on the operational voltage, the upper peak value is equal to the maximum bus operational voltage plus 5% of the mean bus operational voltage, and/or such that the lower peak value is equal to the minimum bus operational voltage minus 5% of the mean bus operational voltage. The limit shall be tailored no more than necessary to meet this subrequirement.

d1. Verification: Basic. Verification shall be by test in accordance with MIL-STD-461F, as modified by this document. Especially see Requirement 4.1 (General Requirements, Units and Subsystems) and the provisions of this Requirement.

d2. Verification: 10uF capacitor across EUT power input leads at LISNs. The 10uF capacitor across the EUT power input leads at the LISNs, shown in MIL-STD-461F, Figure CS101-4, shall be deleted from the test setup.

(X) d3. Verification: Frequency range extension. If the extended frequency range requirements of paragraph c3 are specified by the procuring authority, verification shall be by test using test methods and test equipment approved by the procuring authority. In addition, any limits employed from 30Hz to 5kHz shall also apply to the frequency extension.

d4. Verification: Unit operational voltage levels. The requirement shall be verified by test at one or two unit power operational voltages which meet the following conditions: For unit limits from 30Hz to 5kHz, the unit operational power voltages shall be such that the lower peak of the injected signal shall go under the minimum bus operational voltage by 5% of the mean bus operational voltage, and the upper peak of the injected signal shall exceed the maximum bus operational voltage by 5% of the mean bus operational voltage. This shall be achieved by calculating the operational voltage(s) as follows:

The lower unit operational voltage shall be: the minimum bus operational voltage minus 5% of the mean bus operational voltage plus the amplitude of the injection signal. If the resulting test level is greater than the mean bus operational voltage, verification of this requirement shall be performed only at the mean bus operational voltage. (See Note 2, examples 1 and 2.)

The upper unit operational voltage shall be: the maximum bus operational voltage plus 5% of the mean bus operational voltage minus the amplitude of the injection signal. If the resulting test level is less than the mean bus operational voltage, verification of this requirement shall be performed only at the mean bus operational voltage. (See Note 2, examples 1 and 2.)

If the bus minimum and maximum operational voltages are not known, the unit minimum and maximum operational voltages may be substituted in the above calculations.

d5. Verification: Alternative operational voltage and test limits. Testing may be performed only at the mean bus operational voltage, but the injection signal limit used for the frequency range from 30Hz to 5kHz shall such that the lower peak of the injected signal goes under the minimum bus operational voltage by 5% of the mean bus operational voltage and the upper peak of the injected signal exceeds the maximum bus operational voltage by 5% of the mean bus operational voltage. If this alternative is chosen, the limits from 5kHz to 150kHz shall still form a straight line from the limit at 5kHz to the limit at 150kHz. (See Note 2, example 1.)

(CAUTION! During setup operations, if the EUT is powered on while the injection equipment is off and the coupling transformer secondary is in the power line to the EUT, the EUT may be damaged by a resonance interaction between the EUT power converter and the coupling transformer secondary inductance. One way to mitigate this is to shunt the primary or secondary coil with a resistance. Values which have been used include 2ohms to 50ohms in the primary, or one quarter of this in the secondary. Analyses of stability and allowable power consumption/voltage drop (before setting up the test) can determine the optimum value and help avoid damaging valuable hardware. NASA JPL has developed an alternative test setup not involving transformers, but circuitry to modulate the line voltage directly on the power line. For them, this has proven to be a more-satisfactory solution than damped transformer coils.

(In addition, test risk may be further controlled by monitoring injection current with a broadband current monitor.)

Figure 6.10c1-1. CS101 Voltage Limits

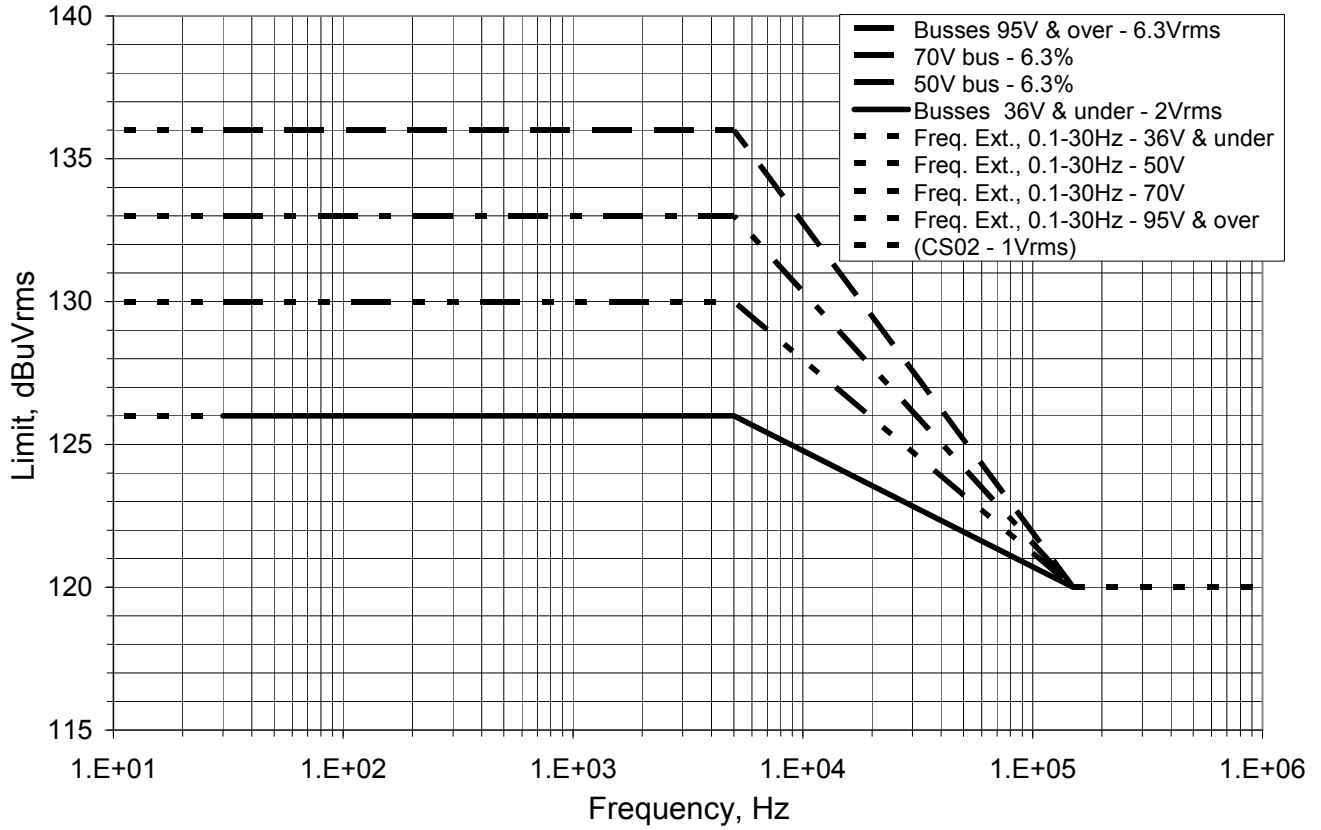
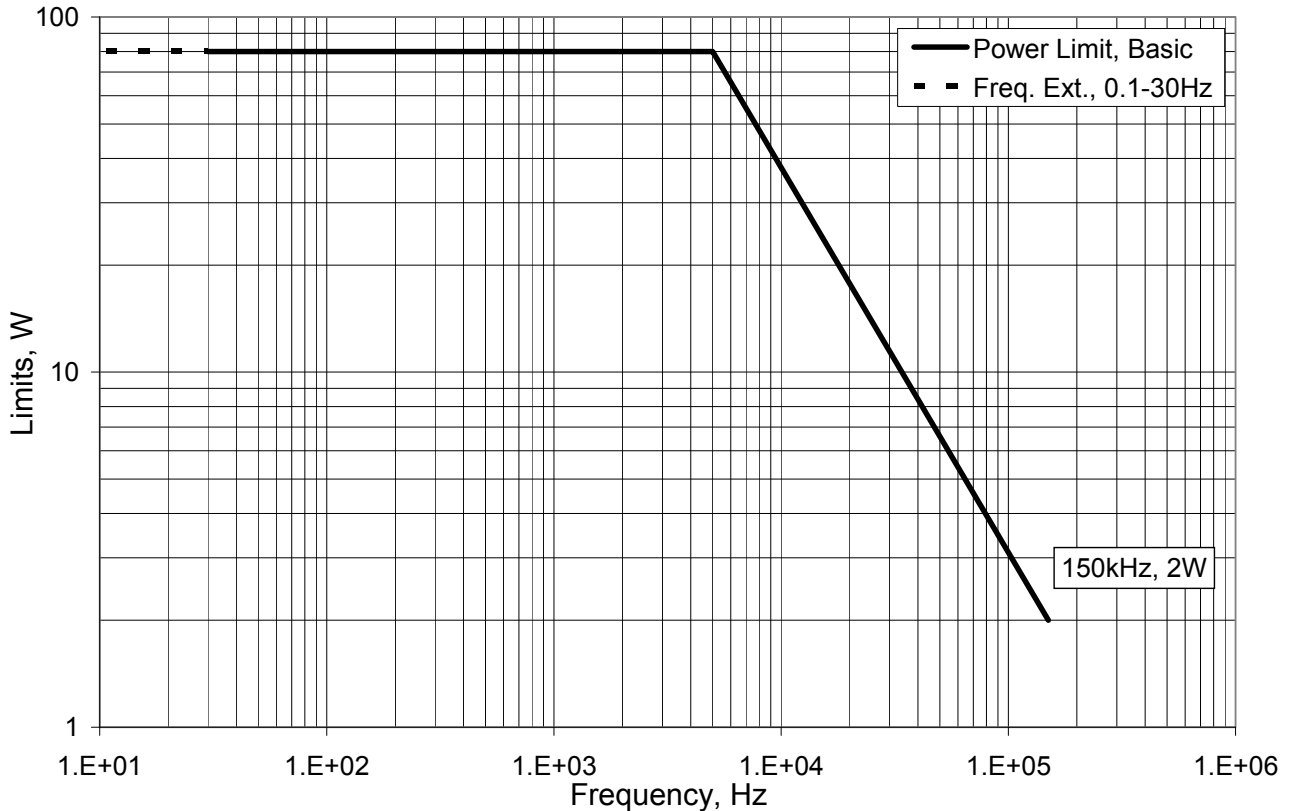

Figure 6.10c2-1. CS101 Power Limits



(Notes:

(1) The lower frequency voltage limits are based on a combination of the ripple limits given in AIAA S-122-2007 (with EMISMs of approximately 12dB for the non-deadband portion of the ripple), and the CS101 limits of MIL-STD-461F. The power limits are calculated from the voltage limits into a 0.5ohm load.

(2) The following give examples of determining limits and operational test voltages.

(Example 1: Equipment will operate on a power bus whose operational voltage range is 22V to 36V. The mean operational voltage is $(22+36)/2=29V$. The minimum bus voltage due to an injected signal is $22V - 5\% \text{ of } 29V = 20.6V$. The maximum bus voltage due to an injected signal is $36V + 5\% \text{ of } 29V = 37.4V$. The injection limit from 30Hz to 5kHz is $2V_{rms}=126dBuV=2.8V_p=5.6V_{p-p}$. The lower unit operational voltage is $20.6V+2.8V=23.4V$, which will cause the bus to swing from 20.6V to 26.2V. The upper unit operational voltage is $37.4V-2.8V=34.6V$, which will cause the bus to swing from 31.8V to 37.4V. As an alternative, the contractor may choose to test from 30Hz to 5kHz at the mean bus operational voltage only, but it would require an injection signal of $37.4V-20.6V=16.8V_{p-p}=5.9V_{rms}=135.5dBuV_{rms}$. In addition, the limit line from 5kHz to 150kHz would be a straight line from 135.5dBuV to 120dBuV.

(Example 2: Equipment will operate on a power bus whose operational voltage range is 54V to 56V. The mean operational voltage is $(54+56)/2 = 55V$. The injection limit from 30Hz to 5kHz is $0.063 \times 55V = 3.47V_{rms} = 130dBuV_{rms} = 4.9V_{pk} = 9.8V_{p-p}$. The upper unit operational voltage is $56V + (0.05 \times 55V) - 4.9V = 53.9V$, which is below the mean bus operational voltage, so only the mean operational voltage is required in this case. In addition, the injection signal is only required to exceed the minimum and maximum operational voltages by 5% of the mean operational voltage, so the limit from 30Hz to 5kHz is $0.05 \times 55 \times 2 + 56 - 54 = 7.5V_{p-p} = 2.65V_{rms} = 128.5dBuV_{rms}$.

6.11 Conducted Susceptibility, Power and Command/Control Lines, 150kHz-50MHz (CS02)

a. Purpose. The purpose of this requirement is to ensure that all equipment will operate compatibly when connected to the same external power source.

b. Applicability. This requirement applies to the external power leads and command/control lines driven directly by external power, including returns and grounds and neutrals not grounded internally to the equipment, of equipment which will be connected to an external power source, for equipment (units and subsystems) which will operate on a launch vehicle or in space.

c1. Requirement: Basic, 150kHz-50MHz. The unit shall not exhibit any malfunction, degradation of performance, or deviation from specified indications, beyond the tolerances indicated in the individual equipment or subsystem specification, when subjected to 1volt rms from a 50ohm source. The test signal shall be applied directly to the equipment input terminals, not through the test sample's power line cord. The requirement is also met under the following condition: when a 1watt source of 50ohms impedance cannot develop the required voltage at the test sample power input terminals, and the test sample is not susceptible to the output of the signal source.

(P) c2. Requirement: Frequency range extension 50MHz-400MHz. If specified by the procuring authority, the required frequency range shall be extended up to 400MHz in accordance with special needs of the program. The limit shall be the same as that at 50MHz.

(P) c3. Requirement: Frequency range extension 50MHz-1GHz. If specified by the procuring authority, the required frequency range shall be extended up to 1GHz in accordance with special needs of the program. The limit shall be the same as that at 50MHz.

d1. Verification: Basic, 150kHz-50MHz. Verification shall be by test in accordance with the following test method.

d1.1 Apparatus. The apparatus shall consist of the following:

- (1) Signal Source. A 50ohm internal impedance and an output voltage of 7volts to a matched load.
- (2) Coupling Capacitor. The capacitor shall be used to isolate the power line frequencies from the signal source and shall have an RF impedance of 5ohms, or less, over the frequency range of the test. The capacitor may be changed during the test to maintain the impedance.
- (3) Oscilloscope or spectrum analyzer.
- (4) LISNs.

d1.2 Test Setup and Procedures. Test setup and procedures shall be as follows:

- (1) Use the general test setup as shown in Figure 6.11d1-1.
- (2) Connect the coupling capacitor and oscilloscope within 5cm of the termination to the test sample.
- (3) Apply the test signal to each power lead.
- (4) When testing equipment using single point grounds, apply the test signal between each power lead and the ground return, and also each power or ground return lead and the ground plane.
- (5) Measure and record the voltage across the terminal of the test sample.
- (6) If the test sample is susceptible to the applicable limit level, decrease the signal source output to determine and record the threshold of susceptibility.

(X) d2. Verification: Frequency range extensions. If the extended frequency range requirements of paragraphs c2 and c3 are specified by the procuring authority, verification in the relevant frequency ranges shall be by test using test methods and test equipment approved by the procuring authority.

(P) d3. Verification: Operational voltages, minimum and maximum. If the percent variation between the maximum steady-state bus operating voltage and the minimum steady-state bus operating voltage is greater than 10%, testing shall be at the two voltage extremes as well as the mean. Alternatively, testing may be specified to be performed only at the expected bus eclipse operational voltage and the expected sun operational voltage. (Percent variation is the difference of two values, divided by their average, times 100.)

d4. Verification: Test signal modulation. See subrequirement 4.1d8(Unit General Requirements, Test signal modulation).

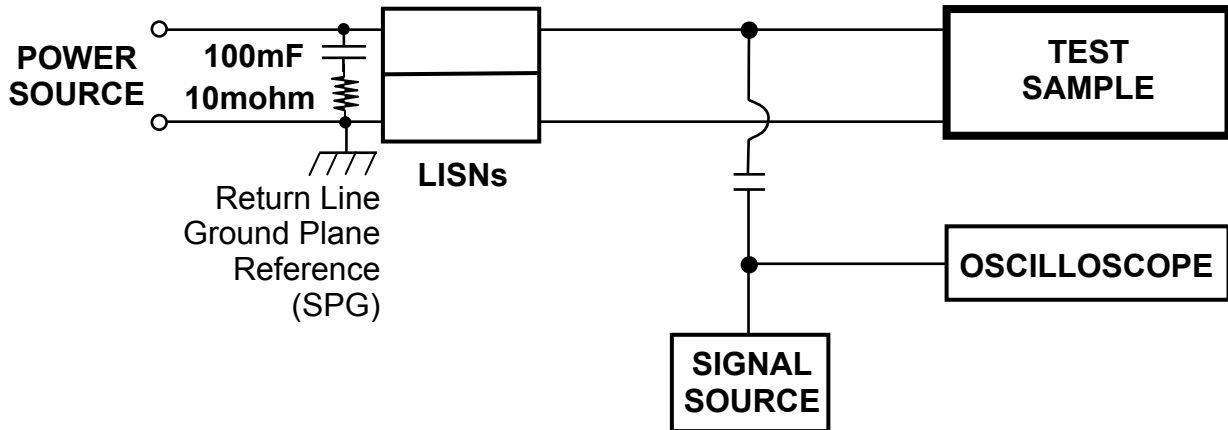

Figure 6.11d1-1. Test Setup (CS02).

6.12 Conducted Susceptibility, Short-Duration High-Level Aperiodic Transients, Power and Command/Control Lines (CS06)

a. Purpose. The purpose of this requirement is to ensure that equipment will not deviate from specified operation while subjected to short-duration, high-level transients on their power leads and command/control lines, resulting from normal vehicle operations or short circuit fault clearing events.

b. Applicability. This requirement applies to the external power leads and command/control lines driven directly by external power, including returns and grounds and neutrals not grounded internally to the equipment, of equipment which will be connected to an external power source, for equipment (units and subsystems) which will operate on a launch vehicle or in space.

c. Requirement. The unit shall not exhibit any malfunction, degradation of performance, or deviation from specified indications, beyond the tolerances indicated in the individual equipment or subsystem specification, when subjected to test spikes having a waveform shown in Figure 6.12c-1. The values of $E_{()}$ and $t_{()}$ shall be:

- | | | |
|-----------------|-------------------------------|--|
| Positive Spike: | $E_{()} = 200\text{volts}$, | $t_{()} = 10\text{microseconds} \pm 20\%$. |
| Negative Spike: | $E_{()} = 200\text{volts}$, | $t_{()} = 10\text{microseconds} \pm 20\%$. |

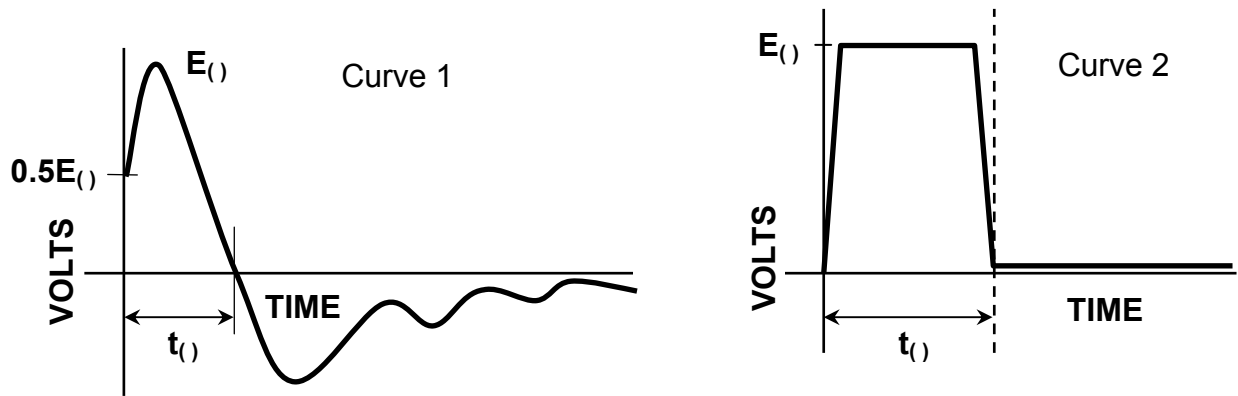

Figure 6.12c-1. Acceptable Waveforms for Requirements 6.12(CS06) and 6.37(RS02).

d1. Verification: Basic. Verification shall be by test in accordance with the following test method.

d1.1 Apparatus. The test apparatus shall consist of the following:

d1.1.1 Spike Generator. The spike generator shall have the following characteristics:

- (1) Pulse Width = 10us
- (2) Pulse Repetition Rate = 3–10pps
- (3) Voltage Output = Not less than 200Vpeak
- (4) Output Control = Adjustable from 0 to 200Vpeak
- (5) Output Spectrum = 160dBuV/MHz at 25kHz decreasing to 115dBuV/MHz at 30MHz
- (6) Phase Positioning = 0–360degrees
- (7) Source Impedance (with injection transformer) = 0.06ohms
- (8) Transformer (current capacity) = 30amperes
- (9) External Synch = 50–800Hz
- (10) External Trigger = 0–20pps

d1.1.2 Capacitor. A 10microfarad feedthrough or other high-frequency-response capacitor.

d1.1.3 Oscilloscope. Any oscilloscope with 10MHz bandwidth and adequate sweep rates is acceptable.

d1.1.4 Series inductor (20uH). The 20uH series inductor in Figure 6.12d1-2 may be replaced with the standard LISNs (and decoupling 100uF/10mohm decoupling components, if desired) if the change does not cause the injection signal to be less than required.

(Note: The purpose of the inductor is to allow the spike generator to inject the required spike amplitude across the EUT power leads, which may not be

possible if the power source impedance loads the injection signal down too much. The two LISNs may provide enough impedance to replace the inductor, and may already be in place for other tests. Another alternative is to leave the CS101 coupling transformer in place with a suitable resistance shunting the primary or secondary winding. However, if the EUT is powered with the CS101 coupling transformer in place but without the shunt resistor, the EUT may be damaged. (Also see the CAUTION at the end of Requirement 6.10(CS101).)

d1.2 Test Procedure. The test procedure shall be as follows:

- (1) Connect test sample and test instrumentation as shown in Figure 6.12d1-1 for equipment powered from AC or DC lines and Figure 6.12d1-2 for equipment powered from DC lines.
- (2) Series, shunt, or both test methods may be used provided that approval has been granted by the procuring authority.
- (3) When a generator with a high source impedance is used, its output shall be calibrated with a 5ohm non-inductive load resistor to verify spike characteristics, as indicated in Figure 6.12d1-3.
- (4) The applied spike amplitude, rise time, and duration, as measured by the oscilloscope across the input terminals of the test sample, shall follow the waveshape and levels specified in this Requirement.
- (5) Synchronization and triggering shall be used to position the spike to specific test sample signal conditions which will produce maximum susceptibility.
- (6) Positive and negative, single and repetitive (6 to 10pps) spikes shall be applied to the test samples ungrounded input lines for a period not to exceed 30minutes in duration. Spikes shall be synchronized to the power line frequency and positioned on each 90degree phase position for a period not less than 5minutes. Positioning of the spike from 0 to 360degrees of the power line frequency is also required. Spike synchronization frequency shall be varied from 50 to 800Hz and its effect on equipment susceptibility noted. On equipment employing digital circuitry, the spike shall be triggered to occur within the time frame of any gate or pulse generated by the logic circuitry.
- (7) If susceptibility occurs, determine and record its threshold level, repetition rate, phase position on the AC waveform, and time occurrence on digital gates.

(P) d2. Verification: Unit operational voltages, minimum and maximum. If the percent variation between the maximum steady-state bus operating voltage and the minimum steady-state bus operating voltage is greater than 10%, the positive spike shall apply at the maximum steady-state bus operating voltage, and the negative spike shall apply at the minimum steady-state bus operating voltage. (Percent variation is the difference of two values, divided by their average, times 100.) *(See tailoring for application guidance.)*

e. Tailoring: Limits and bus voltages. If the amplitude of subrequirement c is not tailored (remains at or above +/-200V), then testing at the mean bus

operational voltage is all that is required (not testing at the minimum and maximum bus voltages). However, if the amplitude is tailored below 200V, then testing in accordance with paragraph d2 should be considered.

(Note: Experimentation with fault clearing events (short circuit leading to fuse opening) on an emulated spacecraft bus has revealed transients of 200V above and 40V below the bus voltage for up to 10us. The bus voltage was 30V. Different bus configurations, bus voltages, and types and sizes of fuses may result in different transient levels. The testing was performed by the Electrical and Electronic Systems Department of The Aerospace Corporation from 2004 to 2007, and a report is pending.)

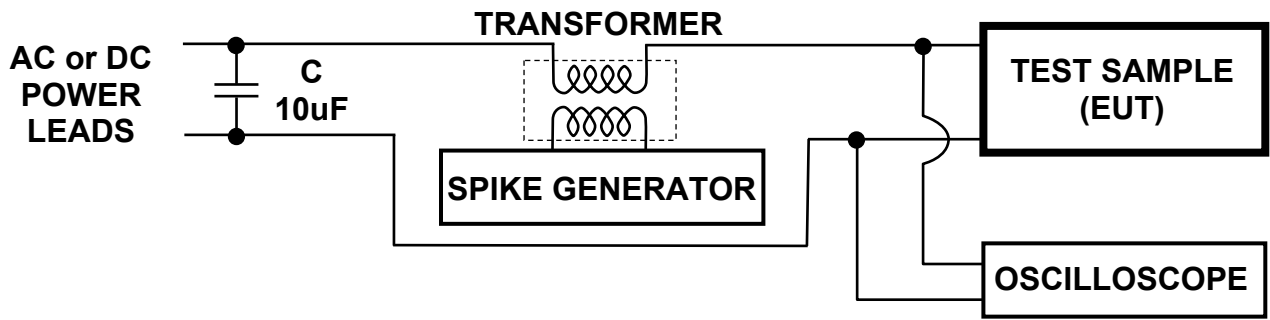
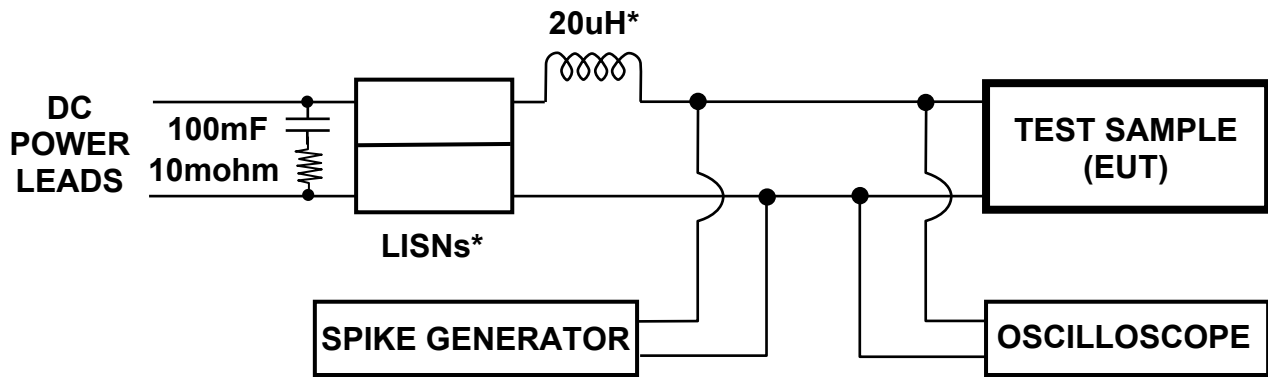

Figure 6.12d1-1. Spike Susceptibility, AC or DC Power, Series Injection (CS06).



*Alternative configurations. See paragraph d1.1.4 and its note.

Figure 6.12d1-2. Spike Susceptibility, DC Power, Parallel Injection (CS06).

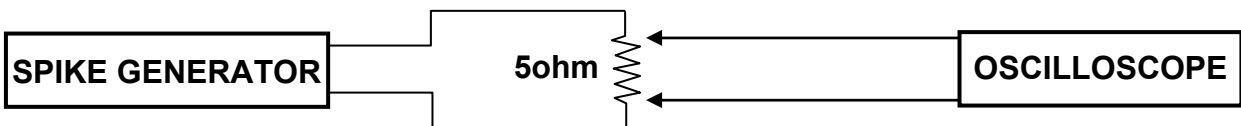

Figure 6.12d1-3. Calibration of High Source Impedance Spike Generator (CS06).

6.13 Conducted Susceptibility, Aperiodic Surges, Operate Through, Power and Command/Control Lines

a. Purpose. The purpose of this requirement is to ensure that equipment will not be susceptible to power surges on their power leads and command/control lines, resulting from normal vehicle operations or short circuit fault clearing events.

b. Applicability. This requirement applies to the external power leads and command/control lines driven directly by external power, of equipment which will be connected to an external power source, for equipment (units and subsystems) which will operate on a launch vehicle or in space.

c1. Requirement: Operating through positive surges. The unit shall not exhibit any malfunction, degradation of performance, or deviation from specified indications, beyond the tolerances indicated in the individual unit specification, when subjected to an input voltage step increase of 20% of its mean operational voltage, as defined in this document, lasting for 40ms, with a rise time of 5us and a fall time of 0.5ms, which begins within the steady-state operational voltage range of the unit and exceeds the maximum operational voltage of the unit by 5% of the mean operational voltage.

In case of conflicting requirement parameters (e.g., the surge, in meeting its 20% requirement, would need to start below the unit minimum operational voltage or exceed the unit maximum operational voltage by more than 5% of the unit mean operational voltage), the surge starting voltage shall be the unit minimum operational voltage, and the surge height (the 20% value) shall be reduced such that its upper voltage shall exceed the unit maximum operational voltage by 5% of the unit mean operational voltage.

c2. Requirement: Operating through negative surges. The unit shall not exhibit any malfunction, degradation of performance, or deviation from specified indications, beyond the tolerances indicated in the individual unit specification, when subjected to an input voltage step decrease of 20% of its mean operational voltage, as defined in this document, lasting for 40ms, with a fall time of 5us and a rise time of 0.5ms, which goes below the minimum operational voltage of the unit by 5% of its mean operational voltage.

In case of conflicting requirement parameters (e.g., the surge, in meeting its 20% requirement, would need to start above the unit maximum operational voltage or go below the unit minimum operational voltage by more than 5% of the unit mean operational voltage), the surge starting voltage shall be the unit maximum operational voltage, and the surge height (the 20% value) shall be reduced such that its lower voltage is no less than the unit minimum operational voltage by 5% of the mean operational voltage.

d. Verification. Verification shall be by test in accordance with methods and procedures approved by the procuring authority.

6.14 Conducted Susceptibility, Aperiodic Surges, Survival and Outrush Current, Power and Command/Control Lines

a. Purpose. The purpose of this requirement is to ensure that equipment will not be damaged or overstressed by power surges on their power leads and command/control lines, resulting from normal vehicle operations or short circuit fault clearing events.

b. Applicability. This requirement applies to the external power leads and command/control lines driven directly by external power, of equipment which will be connected to an external power source, for equipment (units and subsystems) which will operate on a launch vehicle or in space.

c1. Requirement: Surviving positive surges, general equipment. The unit shall remain undamaged and shall not suffer overstress, when subjected to an input voltage step change from its maximum steady-state operational voltage to two times that voltage within $5\mu\text{s}\pm 10\%$, remaining at the elevated voltage for $10\text{ms}\pm 10\%$, and then returning to the initial voltage at a rate of no less than $100\text{mV}/\mu\text{s}\pm 10\%$.

c2. Requirement: Surviving negative surges, general equipment. The unit shall remain undamaged and shall not suffer overstress, when subjected to an input voltage step change from its maximum steady-state operational voltage to 0volts at a rate of no less than $5\text{V}/\mu\text{s}\pm 10\%$, remaining at 0volts for $200\text{ms}\pm 10\%$, and returning to the initial voltage at a rate of no less than $100\text{mV}/\mu\text{s}\pm 10\%$.

c3. Requirement: Surviving positive surges, essential equipment. Essential units shall meet subrequirement c1 and, in addition, shall autonomously recover to a predictable safe state allowing commandability and/or controllability, when subjected to the input voltage step change described in subrequirement c1.

c4. Requirement: Surviving negative surges, essential equipment. Essential units shall meet subrequirement c2 and, in addition, shall autonomously recover to a predictable safe state allowing commandability and/or controllability, when subjected to the input voltage step change described in subrequirement c2.

c5. Requirement: Outrush current. During the input voltage step change from the maximum steady-state operational voltage to 0volts per subrequirement c2, the unit input peak outrush current shall not be greater than ten times the unit maximum steady-state operational current.

d1. Verification: Basic. Verification shall be by test in accordance with methods and procedures approved by the procuring authority.

d2. Verification: Outrush current. The outrush current of this requirement shall be measured as part of the subrequirement c2 test.

(P) e. Tailoring: Outrush current. Equipment may be exempted from subrequirement c5 if there is a procurement requirement for the equipment vendor to provide power input filter schematics to the power bus developer.

(Note: Outrush current may result in bus damage if not limited or otherwise considered in designing the bus.)

6.15 (Reserved)

(P) 6.16 Conducted Susceptibility, Ground Plane Injection, 30Hz-150kHz

a. Purpose. The purpose of this requirement is to ensure that equipment will operate within specification when potential differences exist across platform electrical references.

b. Applicability. This requirement is applicable to equipment connected to a common ground reference. (Also see paragraph e.)

c. Requirement. The equipment shall not exhibit any malfunction, degradation of performance, or deviation from specified indications, beyond the tolerances indicated in the individual equipment or subsystem specification, when subjected to the following test signals between the equipment chassis and the chassis electrical reference.

- 1) A sine wave of 1Vrms from 30Hz-150kHz or
- 2) A sine wave of the currents given in Figure 6.16c-1, if reached before a 1Vrms injection voltage is reached.

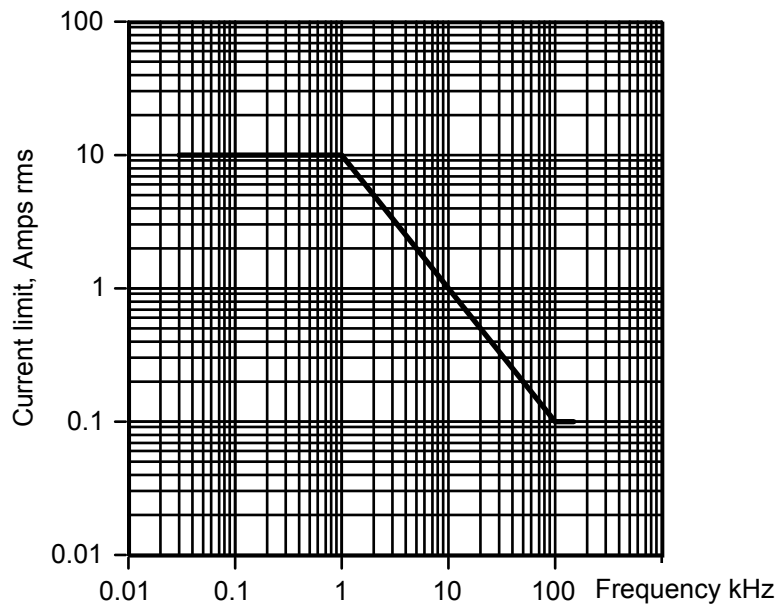

Figure 6.16c-1: Current Limit for Ground Plane Injection, 30Hz-150kHz

d. Verification. Verification shall be by test in accordance with the following test method.

d.1 Test Equipment. The test equipment shall consist of the following:

- 1) Audio frequency signal generator
- 2) Power amplifier
- 3) Oscilloscope
- 4) Coupling transformer
- 5) LISNs
- 6) Current probe

d.2 Test Setup. The test setup shall be as follows:

- 1) Maintain the basic test setup for the EUT IAW MIL-STD-461F (general requirements, as tailored in this document).
- 2) Ensure that all power to the EUT is disconnected.
- 3) Remove the chassis ground tie from the EUT chassis. Isolate the unit from the ground plane and place the unit on an isolating support that is 5cm thick. Connect the test sample and test instrumentation as shown in Figure 6.16d-1. All attachments for signal voltage injection will be between the ground plane and the chassis of the unit.

d.3 Test Procedures. The test procedures shall be as follows:

- 1) Turn on the measurement equipment and allow it to stabilize.
- 2) EUT Testing.
 - (A) Turn on the EUT and allow it to stabilize.
 - (B) Set the signal generator to the lowest test frequency and output level. Increase the signal level until the required voltage or current level is reached on the ground attachment to the test sample enclosure.
 - (C) While maintaining at least the required signal level, scan through the required frequency range in accordance with MIL-STD-461F.
 - (D) Monitor the EUT for degradation of performance. If susceptibility is noted, determine the threshold level IAW MIL-STD-461F.

e. Tailoring: Platforms intentionally returning primary power via structure. Equipment manifested on platforms which intentionally return primary power via the structure instead of dedicated isolated power cabling may especially benefit by having this requirement levied on the program.

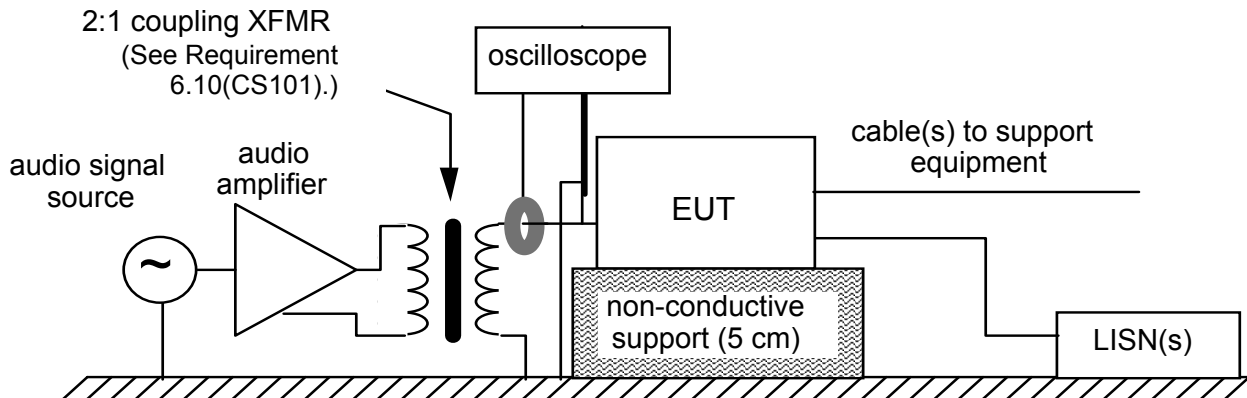

FIGURE 6.16d-1. Test Setup for Ground Plane Injection, 30Hz-150kHz

(P) 6.17 Conducted Susceptibility, Ground Plane Injection, 150kHz-100MHz

a. Purpose. The purpose of this requirement is to ensure that equipment will operate within specification when potential differences exist across platform electrical references.

b. Applicability. This requirement is applicable to equipment connected to a common ground reference. (Also see paragraph e.)

c. Requirement. The equipment shall not exhibit any malfunction, degradation of performance, or deviation from specified indications, beyond the tolerances indicated in the individual equipment or subsystem specification, when subjected to the following test signals between the equipment chassis and the chassis electrical reference.

- 1) A sine wave of 1Vrms from 150kHz-100MHz or
- 2) A sine wave of 280mA_{rms}, if reached before a 1Vrms injection voltage is reached.

d. Verification. Verification shall be by test in accordance with the following test method.

d.1 Test Equipment. The test equipment shall consist of the following. (*MIL-STD-461F, Test Method CS114, may be used as additional guidance for verification equipment.*)

- 1) Signal generator
- 2) Power amplifier
- 3) Oscilloscope
- 4) Current injection probe
- 5) LISNs
- 6) Current measurement probe

d.2 Test Setup. The test setup shall be as follows:

- 1) Maintain the basic test setup for the EUT IAW MIL-STD-461F (general requirements, as tailored in this document).
- 2) Ensure that all power to the EUT is disconnected.
- 3) Remove the chassis ground tie from the EUT chassis. Isolate the unit from the ground plane and place the unit on an isolating support that is 5cm thick. Connect the test sample and test instrumentation as shown in Figure 6.17d-1. Connect the test sample chassis to the ground plane using a bond strap that fits within the current injection probe and the current measurement probe. The susceptibility signal will be inductively injected between the ground plane and the chassis of the unit, using the injection probe placed around the bond strap.

d.3 Test Procedures. The test setup procedures shall be as follows:

- 1) Turn on the measurement equipment and allow it to stabilize.
- 2) EUT Testing.
 - (A) Turn on the EUT and allow it to stabilize.

- (B) Set the signal generator to the lowest test frequency and output level. Increase the signal level until the required voltage or current level is reached on the ground attachment to the test sample enclosure.
- (C) While maintaining at least the required signal level, scan through the required frequency range in accordance with MIL-STD-461F.
- (D) Monitor the EUT for degradation of performance. If susceptibility is noted, determine the threshold level IAW MIL-STD-461F.

e. Tailoring: Platforms intentionally returning primary power via structure. Equipment manifested on platforms which intentionally return primary power via the structure instead of dedicated isolated power cabling may especially benefit by having this requirement levied on the program.

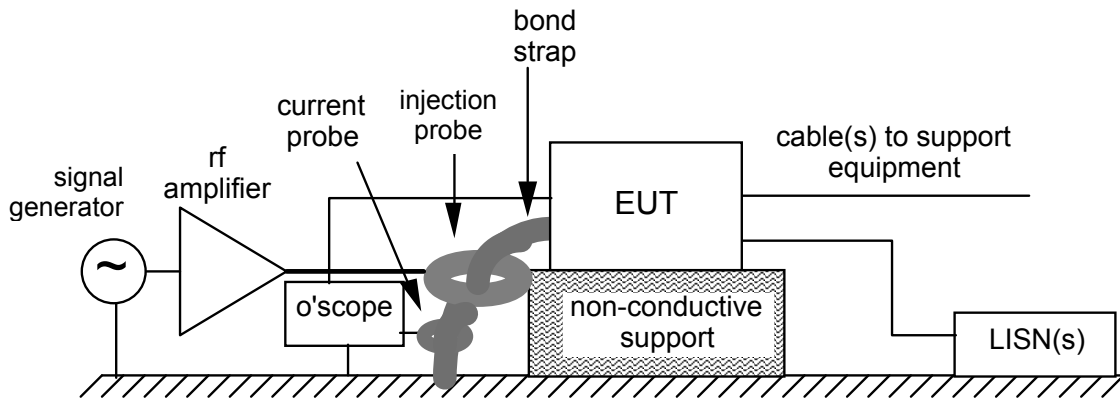

FIGURE 6.17d-1. Test Setup for Ground Plane Injection, 150kHz-100MHz

(P) 6.18 Conducted Susceptibility, Ground Plane Injection, Transient

a. Purpose. The purpose of this requirement is to ensure that equipment will operate within specification when potential differences exist across platform electrical references.

b. Applicability. This requirement is applicable to equipment connected to a common ground reference. (Also see paragraph e.)

c. Requirement. The equipment shall not exhibit any malfunction, degradation of performance, or deviation from specified indications, beyond the tolerances indicated in the individual equipment or subsystem specification, when subjected to the transient waveform given in Figure 6.12c1-1, Curve 1.

- 1) The values of $E_{(t)}$ and $t_{(t)}$ shall be:

Positive Spike:	$E_{(t)} = 8\text{volts,}$	$t_{(t)} = 10\text{microseconds} \pm 20\%.$
Negative Spike:	$E_{(t)} = 8\text{volts,}$	$t_{(t)} = 10\text{microseconds} \pm 20\%.$

 or
- 2) A maximum current amplitude of 16A, if reached before the 8V injection voltage is reached.

d. Verification. Verification shall be by test in accordance with the following test method.

d.1 Test Equipment. The test equipment shall consist of the following. *(Requirement 6.12(CS06) may be used as additional guidance for verification equipment.)*

- 1) Transient (spike) generator
- 2) Oscilloscope
- 3) Current probe
- 4) LISNs

d.2 Test Setup. The test setup shall be as follows:

- 1) Maintain the basic test setup for the EUT IAW MIL-STD-461F (general requirements, as tailored in this document).
- 2) Ensure that all power to the EUT is disconnected.
- 3) Remove the chassis ground tie from the EUT chassis. Isolate the unit from the ground plane and place the unit on an isolating support that is 5cm thick. Connect the test sample and test instrumentation as shown in Figure 6.18d-1, using the transient generator series output terminals for the connections to the EUT and ground plane. All attachments for signal voltage injection will be between the ground plane and the EUT chassis.

d.3 Test Procedures. The test procedures shall be as follows:

- 1) Turn on the measurement equipment and allow it to stabilize.
- 2) EUT Testing.
 - (A) Turn on the EUT and allow it to stabilize.
 - (B) Set the transient generator to the lowest output level. Set the generator to output a positive spike at a rate of 50pps. Increase the signal level until the required voltage or current level is reached on the ground attachment to the test sample enclosure. Apply the test signal for 5 minutes, or until susceptibility is observed, whichever occurs first. Repeat the procedure with a negative spike.
 - (C) Monitor the EUT for degradation of performance. If susceptibility is noted, determine the threshold level IAW MIL-STD-461F.

e. Tailoring: Platforms intentionally returning primary power via structure. Equipment manifested on platforms which intentionally return primary power via the structure instead of dedicated isolated power cabling may especially benefit by having this requirement levied on the program.

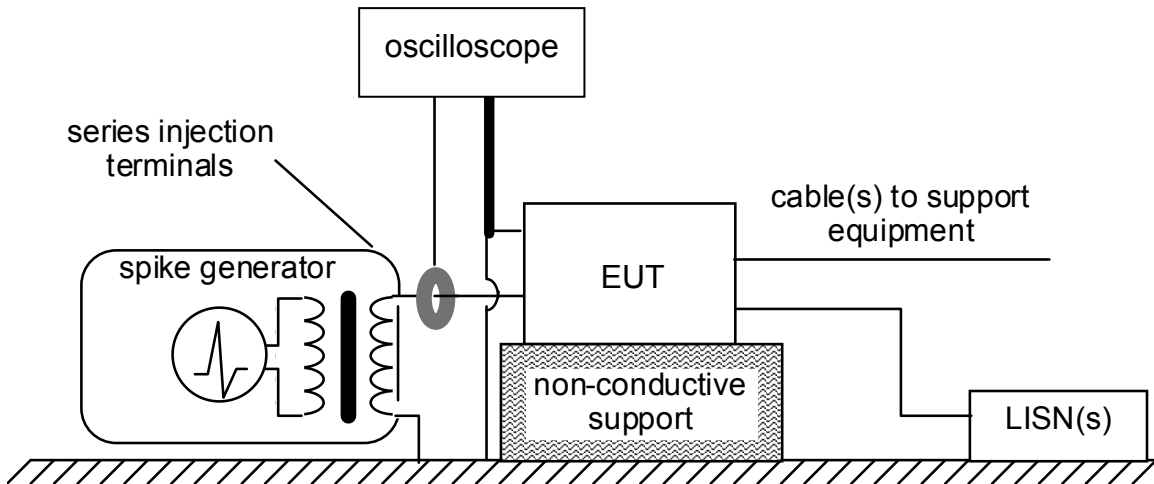

FIGURE 6.18d-1. Test Setup for Ground Plane Injection, Transient

6.19 (Reserved)

ANTENNA INTERFACES AND RADIATED INTERFACES, SPACE EQUIPMENT

6.20 (Reserved)

(L) 6.21 Conducted Susceptibility, Antenna Port, Intermodulation, 15kHz-40GHz (CS103)

a. Purpose. The purpose of this requirement is to ensure that receiving equipment does not exhibit intermodulation effects beyond specified tolerances.

b. Applicability. This requirement applies to receiving equipment per MIL-STD-461F, for equipment which will operate on a launch vehicle or in space.

c. Requirement. The equipment shall meet the requirements of MIL-STD-461F, except that the upper frequency limit is extended to 40GHz.

d. Verification. Verification shall be by test in accordance with MIL-STD-461F, except that the upper frequency limit is extended to 40GHz.

(Notes:

(1) *The MIL-STD-461 upper frequency limits have been in use since 1980 (461B). Meanwhile, receiver and transmitter frequencies have increased. An upper frequency of 40GHz should capture most space situations for now and the near future. If necessary, the upper frequency may be tailored (up or down) for a particular platform and mission.*

(2) *Part of the EMI community believes that the limits and test methods of MIL-STD-461C/MIL-STD-462 should be used for this Requirement, while others believe that standard limits and methods are not useful because they are not relevant to many modern receivers. This latter opinion has resulted in appendix guidance rather than specific limits and methods given in MIL-STD-461F. Future versions of this document will attempt to present specific test limits and methods applicable to most modern receivers.)*

(L) 6.22 Conducted Susceptibility, Antenna Port, Rejection of Undesired Signals, 30Hz-40GHz (CS104)

a. Purpose. The purpose of this requirement is to ensure that receiving equipment does not exhibit any undesired responses to undesired signals beyond specified tolerances.

b. Applicability. This requirement applies to receiving equipment per MIL-STD-461F, for equipment which will operate on a launch vehicle or in space.

c. Requirement. The equipment shall meet the requirements of MIL-STD-461F, except that the upper frequency limit is extended to 40GHz.

d. Verification. Verification shall be by test in accordance with MIL-STD-461F, except that the upper frequency limit is extended to 40GHz.

(Notes:

(1) The MIL-STD-461 upper frequency limits have been in use since 1980 (461B). Meanwhile, receiver and transmitter frequencies have increased. An upper frequency of 40GHz should capture most space situations for now and the near future. If necessary, the upper frequency may be tailored (up or down) for a particular platform and mission.

(2) Part of the EMI community believes that the limits and test methods of MIL-STD-461C/MIL-STD-462 should be used for this Requirement, while others believe that standard limits and methods are not useful because they are not relevant to many modern receivers. This latter opinion has resulted in appendix guidance rather than specific limits and methods given in MIL-STD-461F. Future versions of this document will attempt to present specific test limits and methods applicable to most modern receivers.)

(L) 6.23 Conducted Susceptibility, Antenna Port, Cross Modulation, 30Hz-40GHz (CS105)

a. Purpose. The purpose of this requirement is to ensure that receiving equipment does not exhibit any undesired responses to cross-modulation effects beyond specified tolerances.

b. Applicability. This requirement applies to receiving equipment per MIL-STD-461F, for equipment which will operate on a launch vehicle or in space.

c. Requirement. The equipment shall meet the requirements of MIL-STD-461F, except that the upper frequency limit is extended to 40GHz.

d. Verification. Verification shall be by test in accordance with MIL-STD-461F, except that the upper frequency limit is extended to 40GHz.

(Notes:

(1) The MIL-STD-461 upper frequency limits have been in use since 1980 (461B). Meanwhile, receiver and transmitter frequencies have increased. An upper frequency of 40GHz should capture most space situations for now and the near future. If necessary, the upper frequency may be tailored (up or down) for a particular platform and mission.

(2) Part of the EMI community believes that the limits and test methods of MIL-STD-461C/MIL-STD-462 should be used for this Requirement, while others believe that standard limits and methods are not useful because they are not relevant to many modern receivers. This latter opinion has resulted in appendix guidance rather than specific limits and methods given in MIL-STD-461F. Future versions of this document will attempt to present specific test limits and methods applicable to most modern receivers.)

6.24 Radiated Emissions, Electric Field, 14kHz-18GHz (RE102)

a. Purpose. The purpose of this requirement is to ensure that equipment will not radiate unintentional electric fields in excess of limits which may interfere with receiver equipment.

b. Applicability. This requirement applies to all equipment (units and subsystems) which will operate on a launch vehicle or in space, including equipment designed with antennas permanently mounted, in the receive and standby modes.

c1. Requirement: Basic, 14kHz-18GHz. Units shall meet the requirements of MIL-STD-461F, except that the limits shall be those of Figure RE102-3, the lowest curve, and the frequency range shall be 14kHz to 18GHz. (See Figure 6.24c1-1.)

(P) c2. Requirement: Extended frequency range 20Hz-14kHz. If specified by the procuring authority, the required frequency range shall be extended down to 20Hz in accordance with special needs of the program. The limit shall be the same as that at 14kHz, except in platform receiver notches or as otherwise specified by the procuring authority.

(P) c3. Requirement: Extended frequency range 18GHz-100GHz. If specified by the procuring authority, the required frequency range shall be extended above 18GHz in accordance with special needs of the program. The limit shall be the same as that at 18GHz, except in platform receiver notches or as otherwise specified by the procuring authority. The highest applicable frequency shall be the greater of:

- (1) 10% higher than the upper 3dB BW frequency of the first active stage or preselector filter of any RF receiver on the platform, but no less than 18GHz and no higher than 100GHz, or
- (2) Where platform RF receiver characteristics are unknown: thirty times the highest intentionally generated frequency within the unit, but no less than 18GHz and no higher than 100GHz.

c4. Requirement: Receiver notches. The limits of this requirement shall incorporate all platform receiver notches (passbands) and LNA BWs, including those of the SV, LV and all intermediate stages. Each notch limit shall be the lesser of (1) the level which interferes with the receiver at least link margin while locked, and (2) the level which can interfere with establishing lock at least link margin, minus 12dB for the EMISM, over the receiver respective passband(s) and LNA 3dB BW +/-10% of the BWs for guard bands.

c5. Requirement: Standard receiver notches. Where receiver sensitivities or BWs are not yet known, a conservative estimate shall be made, based on available information and/or expert approximation.

In the absence of more-accurate information, the default receiver notches shall be:

- (1) 400-450MHz, 35dBuV/m (LV)
- (2) 1.2-2.3GHz, 20dBuV/m (communications, GPS, Shuttle)
- (3) 5.59-5.79GHz, 20dBuV/m (LV)
- (4) 7.15-7.19GHz, 20dBuV/m (NASA Deep Space)
- (5) 13.25-15.35GHz, 40dBuV/m (TDRSS)
- (6) 17-17.5GHz, 40dBuV/m (TDRSS)

(See Figures 6.24c1-1 and -2.)

d1. Verification: Basic, 14kHz-18GHz. Verification shall be by test in accordance with MIL-STD-461F, with frequency range and emissions limits as modified herein. Also see Requirement 4.1(General Requirements, Units and Subsystems).

(X) d2. Verification: Extended frequency range 20Hz-14kHz. If subrequirement c2 is specified by the procuring authority, verification shall be by test using test methods and test equipment approved by the procuring authority. (See Note 1.)

(X) d3. Verification: Extended frequency range 18GHz-100GHz. If subrequirement c3 is specified by the procuring authority, verification shall be by test using the test methods of MIL-STD-461F, with changes in antennas, preamplifiers and receiver(s) appropriate for the frequency range(s).

d4. Verification: Platform receiver passband and LNA bandwidths. Emissions verification within the platform receiver passband notches and over LNA BWs shall be performed using BWs representative of platform receiver equipment (e.g., receiver passband BWs and LNA BWs). If the platform has receivers with different BWs, verification shall be performed using all BWs. If test equipment does not have the capability to test exactly to platform receiver BWs, the closest values shall be used and corrections made using a 20dB/decade correction factor, except that “no bandwidth correction factors shall be applied to test data due to the use of larger bandwidths” (MIL-STD-461F paragraph 4.3.10.3.1).

Where platform receiver characteristics are unknown, the BWs of MIL-STD-461F shall be used.

(P) d5. Verification: Alternate receiver notch test methods. If it is not possible to verify the unit radiated emissions requirement within a platform receiver notch using a test receiver BW similar to that of the platform receiver because the industry (not just the equipment provider) lacks adequate test equipment, an alternative method shall be used to demonstrate compatibility at the unit and vehicle levels, but the alternative method shall be approved by the procuring authority.

The following alternate method may be used:

- (1) Using the most sensitive test receiver, antenna and preamp available to the industry, test in the Rx notch at the widest test BW which allows the noise floor to be no greater than approximately 6dB below the platform receiver notch floor.
- (2) Using the most sensitive test receiver, antenna and preamp available to the industry, test in the Rx notch at a test BW similar to, but no greater than, the platform receiver. Make a calibration run with the EUT off, before and after each measurement within the platform receiver notch.

d6. Verification: Dwell times. Emissions verification shall be performed using dwell times longer than EUT response times and long enough to capture EUT emissions to a statistically significant level, but no shorter than the values in MIL-STD-461F Table II. This includes state changes and switching functions of the EUT.

(P) d7. Verification: Dwell times, special events. Such events as state changes and switching functions, which occur at longer intervals than the EUT nominal operational cycle/response times, may be measured by additional tests configured especially for that purpose, as approved by the procuring authority.

d8. Verification: Transmitters. Transmitters shall be verified with flight-like cabling and load attached to the antenna port in place of the antenna.

d9. Verification: Solar array emissions. Radiated emissions resulting from the primary power switching regulator conducting noise onto the solar array (SA) shall be measured. The solar array and its interface to the regulator shall be emulated with realistic wiring, e.g., mounted on a sheet of plywood in the test chamber. A solar array simulator (SAS) shall provide simulated array power, and should be placed outside the test chamber, with power fed through EMI filters in the chamber wall. The regulator shall be placed inside the chamber, unless tested separately. If tested separately, the regulator may be placed outside the chamber, and the lines fed through the chamber wall without filters.

(Note: Placing the SAS and regulator outside the chamber, isolated by EMI filters, will allow testing of the SA emissions alone, and make meeting requirements more likely. Performing this test at the unit level may allow waiving a similar test at the vehicle level.)

(P) d10. Verification: Power line noise injection. Units shall be verified while the power lines are injected with the conducted susceptibility signals of Requirements 6.10(CS101) and 6.11(CS02), with the injected levels relaxed by 6dB. *(Also see paragraph e4 and Note 3.)*

(P) e1. Tailoring: Receiver notches. The receiver notch requirement may be relaxed, with the procuring authority's approval, if it is satisfactorily demonstrated that it is not possible to test to such low levels with test equipment currently available in the industry. The relaxed levels shall be based on the capabilities of the best available test equipment.

In addition, verification in the notches and LNA BWs may be adjusted to allow for sloped skirts in the BWs, as long as the minimum required EMISMs and guard bands are maintained.

(P) e2. Tailoring: Bandwidth correction factors. The 20dB/decade correction factor given in paragraph d4 may be changed to a more accurate methodology if approved by the procuring activity.

(P) e3. Tailoring: Scans above 18GHz. Above 18GHz, where platform receiver characteristics are known, it may be acceptable to scan for RE only within platform receiver bandwidths, if approved by the procuring authority.

(P) e4. Tailoring: Power line noise injection. Equipment within a vehicle structure which serves as an RF shielded enclosure may be exempted from paragraph d10(Power line noise injection) by the procuring authority, if the shield attenuation

is sufficient to reduce the radiated emissions below the susceptibility levels of equipment outside the shield. (In most cases, a shielded enclosure whose proven attenuation is no less than 40dB over all applicable frequencies will be sufficient.)

The RF attenuation of the shielded enclosure shall be demonstrated by test of the actual vehicle or a representative mock-up which includes representative worst-case penetrations, joints, cable entries, etc.

This exemption does not apply to equipment outside of the vehicle structure, nor to equipment within shielded enclosures for which the RF attenuation has not been adequately demonstrated to be sufficient, as approved by the procuring authority.

(Note: Vehicle structures will probably not have the necessary attenuation if they have any of the following characteristics:

(a) insufficient basic material attenuation,

(b) untreated apertures (including RFI-ungasketed joints) whose greatest dimension is greater than one-half wavelength of the highest sensitive equipment frequency of interest, or

(c) cable penetrations using unshielded cables or shielded cables which do not employ bulkhead connectors and circumferential low impedance bonding of the cable shield to the vehicle structure.)

(Notes:

(1) NASA JPL has done extensive RE02 testing in the 20Hz-14kHz frequency range. They have documented test methods which may be available for use by other authorized agencies/programs.

(2) Rather than testing a transmitter with the antenna attached, the requirement was written with flight-like cabling and a realistic load in place of the antenna. It was felt that an RE test with the transmitter antenna transmitting RF would be a problem for test receivers.

(3) Units are typically tested with "clean" power, so their emissions may increase when operated in a system with noisy power, a circumstance which may reveal itself only at vehicle test, unless tested at the unit level with noisy power emulating vehicle operational power. This has happened on programs when a noisy well-shielded unit is connected through the power bus to a quiet poorly-shielded unit at vehicle integration. However, if the poorly-shielded unit is within a validated RF shielded vehicle structure, and sensitive receivers are located outside the structure, then the structure shield can serve in place of a unit shield, and testing of the unit with noisy power may not be needed.

CS101 and CS02 were selected for the injected signals rather than CE tests, because procedures exist for injection of CS signals, but not CE signals. CS06 injection was not included because of the complexity of injecting frequency and time domain signals, and measuring their effects all at the same time. The limits were reduced by 6dB under the assumption that the CS signals have at least 6dB of margin over the CE signals.)

Figure 6.24c1-1. RE102 Limits

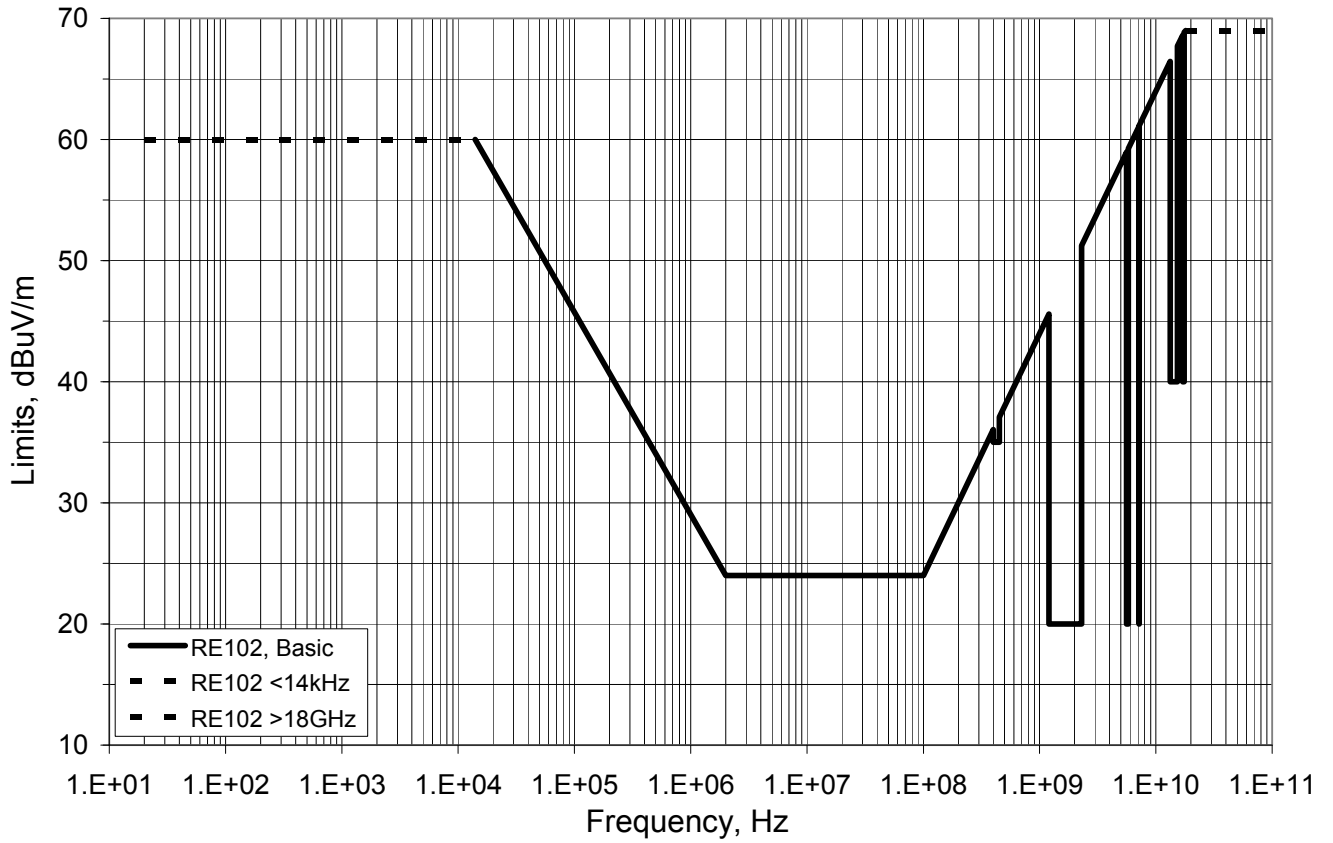
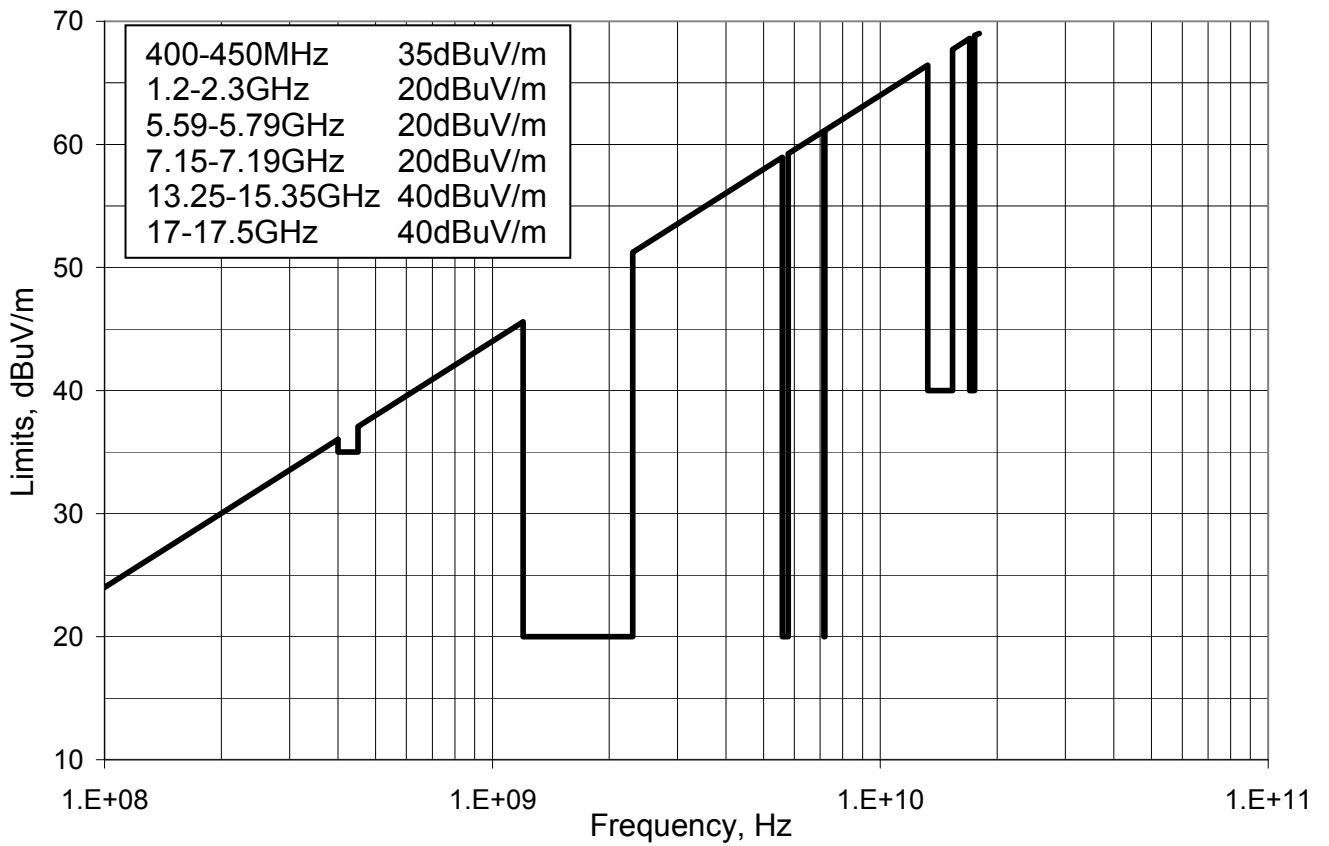

Figure 6.24c1-2. RE102 100MHz-18GHz Detail



(L) 6.25 Conducted Emissions, Antenna Terminal, 10kHz-100GHz (CE106)

a. Purpose. The purpose of this requirement is to ensure that equipment connected to antennas (e.g., transmitters, receivers and RF amplifiers) will not emit unintentional electromagnetic energy at levels that may interfere with antenna-connected receivers on or off the platform.

b. Applicability. This requirement applies to the antenna terminals of transmitters, receivers and amplifiers, for equipment which will operate on a launch vehicle or in space, and for which antenna terminals are readily accessible (antennas not permanently mounted to the antenna terminals). [Requirement 6.26(RE103) is the alternative to this requirement for transmitters with antenna terminals not readily accessible (antennas permanently mounted to the antenna terminals).] Additional applicability is given in MIL-STD-461F.

c1. Requirement: Basic. Units shall meet the requirements of MIL-STD-461F, except that the upper frequency limit shall be the greater of:

- (1) 10% higher than the upper 3dB BW frequency of the first active stage or preselector filter of any RF receiver on the platform, but no less than 18GHz and no higher than 100GHz, or
- (2) Where platform RF receiver characteristics are unknown: thirty times the highest intentionally generated frequency within the unit, but no less than 18GHz and no higher than 100GHz.

c2. Requirement: Receiver notches. The limits of this requirement shall incorporate all platform receiver notches (passbands) and LNA BWs, including those of the SV, LV and all intermediate stages. Each notch shall be constructed in the manner given in subrequirement 6.24c4(RE102, Receiver notches), but converted to dBuV.

c3. Requirement: Standard receiver notches. Where receiver sensitivities or BWs are not yet accurately known, a conservative estimate shall be made, based on available information and/or expert approximation. The default receiver notches shall be those given in subrequirement 6.24c5(RE102, Standard receiver notches), corrected to dBm at the equipment terminal using the antenna factor or gain and any path losses. If antenna factors, gains and path losses are not known, available information and/or conservative expert approximation shall be employed to calculate the corresponding power limits. As a default, the corresponding power values at the unit terminal have been calculated assuming 0dB gain (isotropic) and no path losses or gains, and shall be as follows.

- (1) 400-450MHz, 35dBuV/m= -94dBm = 13dBuV (LV)
- (2) 1.2-2.3GHz, 20dBuV/m= -120dBm = -13dBuV (comm, GPS, Shuttle)
- (3) 5.59-5.79GHz, 20dBuV/m= -134dBm = -27dBuV (LV)
- (4) 7.15-7.19GHz, 20dBuV/m= -134dBm = -27dBuV (NASA Deep Space)
- (5) 13.25-15.35GHz, 40dBuV/m= -120dBm = -13dBuV (TDRSS)
- (6) 17-17.5GHz, 40dBuV/m= -124dBm = -17dBuV (TDRSS)

c4. Requirement: NTIA requirements. The unit or subsystem shall meet NTIA requirements.

d. Verification. Verification shall be by test IAW MIL-STD-461F, except as modified by this document.

(P) e. Tailoring: Scans above 40GHz. Above 40GHz where platform receiver characteristics are known, it may be acceptable to scan for emissions only within platform receiver passbands, if approved by the procuring authority.

(Note: The lower frequency limit is as required by MIL-STD-461F, and the higher frequency limit is as required by MIL-STD-1541A and to be consistent with Requirement 6.24(RE102).)

(L) 6.26 Radiated Emissions, (Transmitter) Antenna Spurious and Harmonic Outputs, 10kHz-100GHz (RE103)

a. Purpose. The purpose of this requirement is to ensure that antenna-connected transmitter equipment will not radiate unintentional electric energy in excess of limits which may interfere with other equipment.

b. Applicability. This requirement applies to antenna-connected transmitter equipment per MIL-STD-461F, for equipment which will operate on a launch vehicle or in space. Requirement 6.25(CE106) may be used as an alternative to this Requirement, but only if this Requirement is not specified by the procuring authority in subrequirement c2.

c1. Requirement: Basic. Units shall meet the requirements of MIL-STD-461F, except that the upper frequency limit shall be the greater of:

- (1) 10% higher than the upper 3dB BW frequency of the first active stage or preselector filter of any RF receiver on the platform, but no less than 18GHz and no higher than 100GHz, or
- (2) Where platform RF receiver characteristics are unknown: thirty times the highest intentionally generated frequency within the unit, but no less than 18GHz and no higher than 100GHz.

(P) c2. Requirement: Transmitters testable to Requirement 6.25(CE106). If specified by the procuring authority, transmitters testable to Requirement 6.25(CE106) shall meet this Requirement.

c3. Requirement: Receiver notches. The limits of this requirement shall incorporate all platform receiver notches (passbands) and LNA BWs, including those of the SV, LV and all intermediate stages. Each notch shall be constructed in the manner given in subrequirement 6.24c4(RE102, Receiver notches).

c4. Requirement: Standard receiver notches. Standard receiver notches shall be in accordance with subrequirement 6.24c5(RE102, Standard receiver notches).

c5. Requirement: NTIA requirements. The unit or subsystem shall meet NTIA requirements.

d1. Verification: Basic. Verification shall be by test in accordance with MIL-STD-461F, except as modified by this document (e.g., the frequency range given in subrequirement c1 and the limits given in subrequirements c3, c4 and c5).

d2. Verification: Receiver notches. Values in receiver notches shall be verified by calculating the values in V/m or dBuV/m at 1meter from the EUT in the worst case direction.

e1. Tailoring: Transmitters testable to Requirement 6.25(CE106). In imposing subrequirement c2, consideration should be given to the transmitter frequency (verification is more difficult below 1GHz because of the geometries involved for long wavelengths), the transmitter power (higher power is more of a threat to other equipment), and the difficulties of performing the test (geometries involved, adequately-sized anechoic chamber, RF regime test equipment and test setups.)

(P) e2. Tailoring: Scans above 40GHz. Above 40GHz where platform receiver characteristics are known, it may be acceptable to scan for RE only within platform receiver bandwidths, if approved by the procuring authority.

(Notes:

(1) The tailoring of the frequency range is from MIL-STD-1541A.

(2) This requirement and Requirement 6.25(CE106) are not mutually inclusive. CE106 imposes requirements on more equipment (antenna-connected transmitters, receivers and amplifiers), but verification lacks the fidelity of antennas, while RE103 imposes requirements on transmitters only, but verifies emissions more realistically with antennas attached.)

6.27 Radiated Susceptibility, Electric Field, 10kHz-40GHz (RS103)

a. Purpose. The purpose of this requirement is to ensure that equipment will not be damaged, overstressed, or operate outside specified performance limits when subjected to electric fields intentionally generated by intrasystem or intersystem equipment (e.g., intentional RF transmitters).

b. Applicability. This requirement applies to all equipment (units and subsystems) which will operate on a launch vehicle or in space.

c1. Requirement: Basic, 10kHz-40GHz, operational. Units shall meet the requirements of MIL-STD-461F, RS103, except that the frequency ranges and limits shall be as in Table 6.27c1-1, and as tailored below in this Requirement. *(Also see Figure 6.27c1-1 for a graphic display of the requirements.)*

(CAUTION: Some levels have no EMISM against known off-platform sources.)

Table 6.27c1-1. Minimum RFI Susceptibility Levels (RS103).*

Frequency	Limit Levels, V/m
10kHz-100MHz	20 ^{2,3}
100-300MHz	20 ³
300MHz-1.8GHz	50 ⁴
1.8-11GHz	120 ⁵
11-40GHz	30 ⁴

* Based on 100nmi polar orbit, with some experimental and test sources not included (see paragraph e2 and Table 6.27e2-1 with its notes).

² MIL-STD-464A, Table 1C, External EME for Space and Launch Vehicle Systems.

³ MIL-STD-461F, Table VII, RS103 Limits, last column (space).

⁴ NASA Contractor Report 4776.

⁵ NASA Contractor Report 4776, reduced threat level if certain experimental sources are ignored. According to the report, these sources should "not be considered a normal threat to nominal system performance for purposes of design and test requirements." By accepting the remote likelihood but severe consequences of these sources illuminating a satellite, the procurement can reduce the requirements to those indicated. Possible severe consequences can be mitigated by imposing survival requirements (subrequirement c3) on the program.

c2. Requirement: Platform transmitters. The limits of subrequirement c1 shall be increased to include platform transmitter levels adjusted up by 12dB of EMISM.

(P) c3. Requirement: Equipment survival. Equipment shall remain undamaged and not suffer overstress due to the levels of Table 6.27c3-1 while the equipment is turned off and in stowed configuration, including receivers and transmitters while antennas are attached, if that is how they are stowed. (Also see Figure 6.27c1-1 for a graphic display of the requirements.)

(CAUTION: Some levels have no EMISM against known off-platform sources.)

Table 6.27c3-1. RFI Survival Levels while Off and Stowed (RS103).*

Frequency	Limit Levels, V/m
10kHz-2MHz	25 ¹
2-100MHz	50 ¹
100-1000MHz	100 ²
1-4GHz	250 ⁶
4-11GHz	500 ⁷
11-40GHz	50 ⁹

* Some equipment, such as the LNAs used in the front ends of RF receivers, are very susceptible to RFI damage even when not powered.

¹ MIL-STD-464A, Table 1D, External EME for Ground Systems.

² MIL-STD-464A, Table 1C, External EME for Space and Launch Vehicle Systems. Note that this is far less than the 1500V/m requirement of MIL-STD-464A for ground systems (Note 1).

⁶ According to Aerospace Report No. TOR-2005(1663)-3790, there is one source at one location at CCAFS at 250V/m in this frequency range which may be difficult to mitigate. In addition, 250V/m envelops all sources at calculated locations at CCAFS from 1-4GHz, without source control, and all levels reported in the RF Power Impingement Analysis discussed in Note 7. Also, 250V/m is only 50V/m above the MIL-STD-464A requirement for external EME for Space and launch vehicle systems (Note 2), but far less than the 2500V/m requirement

of MIL-STD-464A for ground systems (Note 1). **However, the 250V/m limit provides NO EMISM for survival against at least one CCAFS source.**

⁷ According to the *RF Power Impingement Analysis, 1997 and 1998 composite analyses for Titan Core Vehicle from 0 to 80nmi (an internal Aerospace Corp. briefing written by D. Oltrogge and A. C. Bustillos)*, there is a source capable of generating approximately 1000V/m, with approximately 11 RFI threats between 100 and 500V/m in the frequency range from 4-11GHz. In addition, Aerospace Report No. TOR-2005(1663)-3790 shows four locations at CCAFS with field strengths in the 4-11GHz range from 1000-43000V/m, plus about 35 occurrences of field strengths from 100 to 500V/m. 500V/m was chosen as a compromise which captures most of the identified RFI threats in the 4-11GHz range (those below 500V/m). However, the compromise is still far less than the 2500V/m requirement of MIL-STD-464A for ground systems (Note 1), and **the 500V/m limit provides NO EMISM for survival against at least one on-orbit terrestrial source at a 100nmi or lower orbit.**

⁹ MIL-STD-461F, Table VII, RS103 Limits, column 9 (ground). Note that this is far less than the 2500V/m requirement of MIL-STD-464A for ground systems (Note 1).

c4. Requirement: Frequency range extension 40GHz-100GHz, platform sources. If the platform has transmit sources within the 40-100GHz frequency range, subrequirement c1 shall be extended to a maximum of 100GHz, but the limits shall apply only to the transmitter sources and their harmonics. The limits shall be in accordance with subrequirement c2.

(P) c5. Requirement: Frequency range extension 40GHz-100GHz, external sources. If specified by the procuring authority, the required frequency range shall be extended up to 100GHz in accordance with special needs of the program. The limit shall be 20V/m, unless a defined threat at a higher level is identified, in which case that higher level shall be employed, unless otherwise specified or approved by the procuring authority.

c6. Requirement: Antenna-connected equipment LNAs, operate-through. Antenna-connected equipment (receivers, transmitters and amplifiers) shall meet subrequirements c1 and c2 within their LNA 3dB bandwidths, but excluding their operational 3dB passbands, while in their normal operational modes and configurations.

(P) c7. Requirement: Antenna-connected equipment LNAs, survival. Antenna-connected equipment (receivers, transmitters and amplifiers) shall remain undamaged and not suffer overstress due to the levels of Table 6.27c3-1 within their LNA 3dB bandwidths, but excluding their operational 3dB passbands, while configured in their respective operational, transport, storage, processing and launch configurations. However, if a defined threat at a higher level is identified, that higher level shall be employed with a 12dB EMISM for platform sources and a 6dB EMISM for off-platform sources.

c8. Requirement: Antenna-connected equipment passbands, operate-through. The equipment shall meet subrequirement c1 within its operational 3dB passbands, at a level 20dB above the platform limits for RE102 within those passbands. *(This is intended to be verified without an attached antenna, per paragraph d3.)*

(P) c9. Requirement: Antenna-connected equipment passbands, survival.

Antenna-connected equipment (receivers, transmitters and amplifiers) shall remain undamaged and not suffer overstress when subjected to 20V/m within their operational 3dB passbands, unless a defined threat at a higher level is identified, in which case that higher level shall be employed with a 12dB EMISM for platform sources and a 6dB EMISM for off-platform sources.

d1. Verification: Basic, 10kHz-100GHz. Verification shall be by test in accordance with MIL-STD-461F for all frequencies required for a particular program, except as modified by this document. *(See especially the other paragraphs of this Requirement and Requirement 4.1(General Requirements, Units and Subsystems).)*

d2. Verification: Test signal modulation. Test signal modulation shall be in accordance with Requirement 4.1d8(General Requirements, Test signal modulation).

d3. Verification: Antenna-connected equipment. Antenna-connected equipment (receivers, transmitters and amplifiers) shall be tested with flight-like cabling and antennas attached. If flight-like cabling and/or antennas are not available, this Requirement, as tailored and/or specified, shall be verified by direct injection into the antenna ports in accordance with Requirement 6.28(Antenna Port Direct Injection(RS103alt), in addition to testing in the RF regime in accordance with this Requirement.

However, subrequirement c8(Antenna-connected equipment passbands, operate-through) shall be tested without the antenna attached, if practicable, and subrequirement c8 is exempt from verification IAW Requirement 6.28(Antenna Port Direct Injection(RS103alt).

d4. Verification: Dwell times. For all platform transmit frequencies, the verification dwell time shall be 20minutes. For all other frequencies, dwell time shall be long enough for EUT response to occur and be observed, or 3seconds, whichever is greater.

d5. Verification: Combining tests. If survival testing is specified by the procuring authority, test time may be saved by testing for RS103 susceptibility at survival levels, thus meeting susceptibility and survival test requirements with one test.

(P) e1. Tailoring: Frequency range over 100GHz. The frequency range shall be expanded to include on-board transmitters and known external transmitters above 100GHz which may affect vehicle equipment. Verification shall be by test or analysis and the limit shall be 20V/m, unless otherwise specified or approved by the procuring authority.

e2. Tailoring: Increased levels. If any equipment may experience levels which exceed the limits given in Table 6.27c1-1 or 6.27c3-1 (if specified) for any phase of processing, transport, launch or on-orbit operations, the required limits shall be increased to the highest levels identified, plus safety margins where required. This includes onboard transmitters, orbits of less than 100nmi, or particularly RF-hazardous transport routes. Table 6.27e2-1 provides guidance for tailoring, and Figure 6.27c1-1 gives a graphic summary of the requirements and environments.

(CAUTION: Some levels have no EMISM against known off-platform sources.)

Table 6.27e2-1. RFI Susceptibility and Survival Limits (V/m) for Worst-Case (Polar) Orbit and Any Launch Area (RS103).*

Frequency	Factory/transport, Launch processing, Launch pad	Ascent	On-orbit, Altitude 100nmi	On-orbit, Altitude 500km	On-orbit, Altitude 1000nmi
10kHz-2MHz	25 ¹ (20 ^{2,3})	20 ^{2,3}	20 ^{2,3}	20 ^{2,3}	20 ^{2,3}
2-100MHz	50 ¹ (20 ^{2,3})	20 ^{2,3}	20 ^{2,3}	20 ^{2,3}	20 ^{2,3}
100-1000MHz	100 ² (1500 ¹)	100 ² (1500 ¹)	50 ⁴ (40 ⁵) (100 ²)	20 ^{3,4} (100 ²)	20 ³ (100 ²)
1-1.8GHz	250 ⁶ (200 ² , 2500 ¹)	200 ² (2500 ¹)	40 ⁴ (200 ²)	20 ^{3,4} (200 ²)	20 ³ (200 ²)
1.8-4GHz	250 ⁶ (200 ² , 2500 ¹)	200 ² (2500 ¹)	110 ⁴ (200 ²)	40 ⁴ (200 ²)	20 ^{3,4} (200 ²)
4-11GHz	500 ⁷ (1000 ⁷ , 2500 ¹ , 44000 ⁸)	1000 ⁷ (2500 ¹)	120 ⁵ (500 ⁴ , 200 ²)	50 ⁵ (200 ⁴ , 200 ²)	20 ^{3,5} (50 ⁴ , 200 ²)
5-6GHz	44,000 ⁸				
6-8GHz			500 ⁴	200 ⁴	50 ⁴
9-10GHz	9100 ⁸				
9-11GHz			300 ⁴	120 ⁴	30 ⁴
11-40GHz	50 ⁹ (1500 ¹)	20 ^{2,3} (1500 ¹)	30 ⁴	20 ^{2,3}	20 ^{2,3}
(40-100GHz) ¹⁰	(20)	(20)	(20)	(20)	(20)

* Values in **boldface type** are those used for the limits of subrequirements 6.27c1 and 6.27c3.

¹ MIL-STD-464A, Table 1D, External EME for Ground Systems.

² MIL-STD-464A, Table 1C, External EME for Space and Launch Vehicle Systems.

³ MIL-STD-461F, Table VII, RS103 Limits, last column (space).

⁴ NASA Contractor Report 4776.

⁵ NASA Contractor Report 4776, reduced threat level if certain experimental sources are ignored. According to the report, these sources should "not be considered a normal threat to nominal system performance for purposes of design and test requirements." By accepting the remote likelihood but severe

consequences of these sources illuminating a satellite, the procurement can reduce the requirements to those indicated.

- ⁶ Aerospace Report No. TOR-2005(1663)-3790, one source at one location at CCAFS, may be difficult to mitigate.
- ⁷ According to the RF Power Impingement Analysis, 1997 and 1998 composite analyses for Titan Core Vehicle from 0 to 80nmi (an internal Aerospace Corp. briefing written by D. Oltrogge and A. C. Bustillos), there is a source capable of generating approximately 1000V/m, with approximately 11 RFI threats between 100 and 500V/m in the frequency range from 4-11GHz. In addition, Aerospace Report No. TOR-2005(1663)-3790 shows four locations at CCAFS with field strengths in the 4-11GHz range from 1000-43000V/m, plus about 35 occurrences of field strengths from 100 to 500V/m. 500V/m is a compromise which captures most of the identified RFI threats in the 4-11GHz range (those below 500V/m). Note that the compromise is still far less than the other given levels (1000, 2500 and 44000V/m).
- ⁸ If unmitigated by source control, Aerospace Report No. TOR-2005(1663)-3790 shows that levels can range up to 44000V/m, depending on the location. Source control can reduce the levels to below 60V/m at all locations, except for one location and one source which remains at 9100V/m.
- ⁹ MIL-STD-461F, Table VII, RS103 Limits, column 9 (ground).
- ¹⁰ In accordance with subrequirements c4 and c5 (frequency extensions) above.

(Other notes on Table 6.27e2-1:

(There are some inconsistencies between the various standards and RF environment documents (MIL-STD-464A, MIL-STD-461F and space threat documents and data bases). Table 6.27e2-1 is an attempt to capture the worst-case limits from the references. In addition:

(1) Identified transmitters may increase their power levels, and new transmitters may come on-line which have power levels as high or higher than those represented in the table. Consequently, the levels given in the table envelop the actual identified levels and probably represent a more benign environment than will exist in the future.

(2) 100V/m at 2-2.5GHz and 5.4-5.9GHz is the level which the EELV LV may transmit IAW the Evolved Expendable Launch Vehicle Standard Interface Specification, para. 3.2.6.1.3. Other LVs may have different requirements.

(3) On orbit, correction for orbit altitudes is linear. The table provides three representative altitudes. 1nmi=1.852km.)

- (P) e3. Tailoring: Reduced levels.** Levels may be reduced from the required levels in Tables 6.27c1-1 and 6.27c3-1 if it is demonstrated that lower levels represent the actual RFI threats to the unit for its entire service life, but only if approved by the procuring authority. (Heritage arguments for lower levels are insufficient, since the RF environment varies considerably in space and time, since changes in technology and design can have considerable impact on equipment sensitivities, and since most heritage equipment is not tested to actual interference levels.)

Examples:

- (1) On-orbit levels may be reduced from those at 100nmi to those at a higher altitude, using linear extrapolation.
 - (2) Very low inclination orbits may not experience some of the higher-level sources.
 - (3) Transport and/or payload processing may be within an enclosure providing a (verified) level of RF shielding effectiveness. (Payload fairings do not generally provide reliable shielding effectiveness.)
 - (4) Levels may be reduced for various ground processing phases, if impinging (base and mobile) sources are positively controlled to lower levels.
 - (5) Transport levels may be reduced if a more benign route or time of day is selected.
 - (6) Equipment sensitivity levels may be relaxed by the use of RF shielding for sensitive equipment elements (e.g., receiver antenna "hats").
- (P) e4. Tailoring: Receivers.** For receivers within their intended operational receiver notches, more stringent and/or recovery requirements may be imposed by a specific program. For instance, it may be desired by a program that the receiver operate through the test signals or automatically recover after being upset by the signals.
- (P) e5. Tailoring: High power microwave (HPM).** The levels of Tables 6.27c1-1 and/or 6.27c3-1 shall be increased to include hostile RF threats as provided and required by the procuring activity.
- e6. Tailoring: Mission phases.** The limits given in Tables 6.27c1-1 and 6.27c3-1 assume that the unit will be powered off until it is on orbit. If this assumption is not valid, adjustments may need to be made in the limits given in the tables. Although particularly relevant to launch vehicles, this may also apply to payload equipment.
- e7. Tailoring: Combining test levels.** In performing the tests, different RFI envelopes apply to different phases of development and operations. In the interest of reducing test time, an overall worst-case envelope may be developed from the individual envelopes and applied only for an operational system. In other words, testing to higher levels when equipment is not operational and lower levels when equipment is operational may be combined into a single test at the higher levels with all equipment operational. In performing such a combined test, test levels should start below the lower levels and be raised up to the higher levels, noting lowest susceptibility levels for operational requirements, and proceeding to the higher levels to determine if survival is a problem there. If risk of damaging the equipment at the higher levels develops, the test may be halted and redone (for survival alone) at the higher levels with the equipment off.

Figure 6.27c1-1. RS103 Limits and Environments

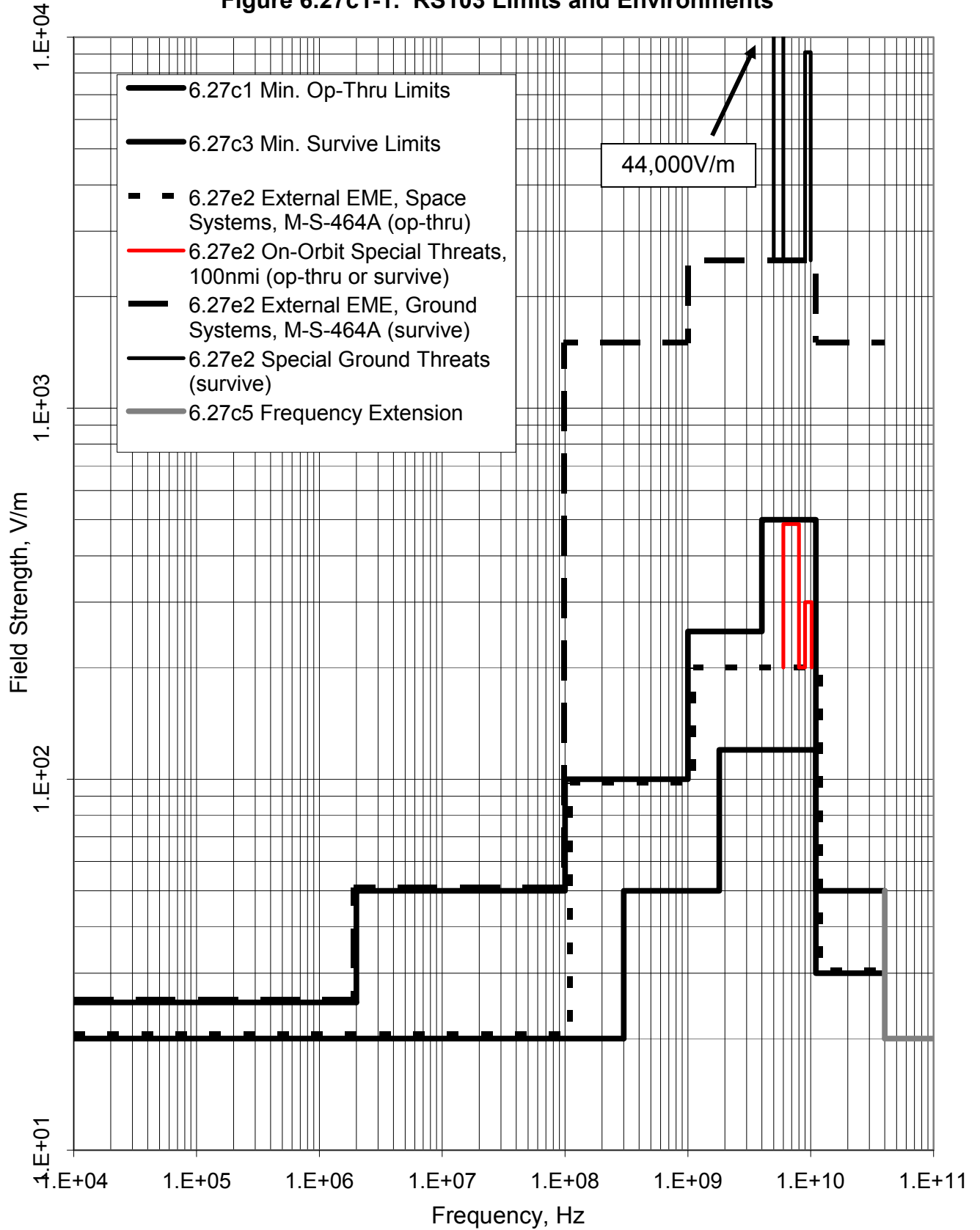

(L) 6.28 Conducted Susceptibility, Antenna Port Direct Injection (RS103alt)

a. Purpose. -The purpose of this requirement is to verify Requirement 6.27(RS103) for equipment connected to antennas (e.g., transmitters, receivers and RF amplifiers) when an operational or equivalent antenna is not available for verification in the RF regime.

b. Applicability. This requirement applies to equipment connected to antennas (e.g., transmitters, receivers and RF amplifiers) which will operate on a launch vehicle or in space, and for which an operational or equivalent antenna is not available for verification in the RF regime in accordance with Requirement 6.27(RS103).

c. Requirement. Equipment connected to antennas (e.g., transmitters, receivers and RF amplifiers) shall meet the requirements of Requirement 6.27(RS103) when an operational or equivalent antenna is not available for verification in the RF regime. This includes all subrequirements specified for Requirement 6.27(RS103).

d1. Verification. Verification shall be by test. The direct injection values shall be calculated from the RF levels of Requirement 6.27(RS103) and antenna parameters. If interface cabling is not available, that shall be modeled into the direct injection levels. Test frequencies shall include at least three frequencies per decade. If testing is required within the 3dB passband(s) of LNAs and equipment operational passbands, test frequencies shall include at least three frequencies per decade, at least one of which is at the most sensitive frequency in the passband, but there shall be no less than three test frequencies per passband.

d2. Verification: Test signal modulation. Test signal modulation shall be in accordance with subrequirement 4.1d8(General Requirements, Test signal modulation).

d3. Verification: Dwell times. For all platform transmit frequencies, the verification dwell time shall be 20minutes. For all other frequencies, dwell time shall be long enough for EUT response to occur and be observed, or 3seconds, whichever is greater.

(P) 6.29 Radiated Susceptibility, Wideband

a. Purpose. The purpose of this requirement is to ensure that equipment will not be damaged, overstressed, or operate outside specified performance limits when subjected to electric fields generated by ion thrusters (e.g., arcjets, Hall thrusters).

b. Applicability. This requirement applies to units and subsystems which will operate on a launch vehicle or in space and be subjected to the EMI of ion thrusters.

c. Requirement. *(This requirement will be included in a future version of this document.)*

d. Verification. *(This verification will be included in a future version of this document.)*

e. Tailoring: Verification dwell times. Dwell times shall be long enough for equipment response to occur and be observed, or 3seconds, whichever is greater.

CABLE BUNDLE INTERFACES AND MAGNETICS, SPACE EQUIPMENT

6.30 Conducted Susceptibility, Bulk Cable Injection, 10kHz-200MHz (CS114)

a. Purpose. The purpose of this requirement is to ensure that equipment with external cables will not operate outside specified performance limits when those cables are subjected to antenna transmissions both on and off the platform.

b. Applicability. This requirement applies per MIL-STD-461F, to equipment with external interconnecting wires and cables, for equipment which will operate on a launch vehicle or in space.

c1. Requirement: Basic, 10kHz-200MHz. The equipment shall meet the requirements of MIL-STD-461F, with limits given in Figure CS114-1, Curve # 3.

(P) c2. Requirement: Frequency range extension 200MHz-400MHz. If specified by the procuring authority, the required frequency range shall be extended up to 400MHz in accordance with special needs of the program. The limits shall be a linear extrapolation of the curve from 30MHz to 200MHz, unless otherwise specified by the procuring authority.

d1. Verification: Basic, 10kHz-200MHz. Verification shall be by test in accordance with MIL-STD-461F, with the test signals applied to the following cables and wires.

- (1) Each and every complete cable bundle interfacing with an electrical connector on the EUT or penetrating the EUT boundary without a connector. This includes signal cable bundles, power cable bundles, mixed use cable bundles, individual wires using their own dedicated connectors or penetrations and individual coaxial cables using their own dedicated connectors or penetrations. *(This is a paraphrase of MIL-STD-461F procedures.)*
- (2) The power leads grouped together separately (including returns and neutrals), for cable bundles which include power and other leads. *(This is a paraphrase of MIL-STD-461F procedures.)*
- (3) The power leads grouped together separately, but with returns and neutrals removed, for power cable bundles and for cable bundles which include power and other leads. *(This is a paraphrase of MIL-STD-461F procedures.)*
- (4) The power returns grouped together separately and the power neutrals grouped together separately, for power cable bundles and for cable bundles which include power and other leads. *(This is a new requirement not in the MIL-STD-461F procedures.)*
- (5) (1) to (4) above also apply to cable bundles or wires which are routed separately but connect to the same connector. *(This is an expansion of the MIL-STD-461F procedures.)*

(X) d2. Verification: Frequency range extension. If the extended frequency range requirements of paragraph c2 are specified by the procuring authority, verification shall be by test using test methods and test equipment approved by the procuring authority.

d3. Verification: Test signal modulation. See subrequirement 4.1d8(Unit General Requirements, Test signal modulation).

(P) e. Tailoring: Shielded cables. Power cables which, in the unit operational (e.g., flight) configuration, are shielded from the power source to the unit, are exempt from subrequirements d1(2), d1(3) and d1(4), if approved by the procuring authority. Cables which contain power and other wires, all of which are completely shielded from the EUT to final loads or sources, are also exempt from subrequirements d1(2), d1(3) and d1(4), if approved by the procuring authority. Cables which are mostly shielded may be considered for exemption from subrequirements d1(2), d1(3) and d1(4), but will need stronger justification than completely shielded cables, and will also require approval by the procuring authority.

6.31 Conducted Susceptibility, Bulk Cable Injection, Impulse Excitation (CS115)

a. Purpose. The purpose of this requirement is to ensure that equipment with external cables will not operate outside specified performance limits when subjected to the effects of platform switching operations and external transient environments, such as lightning and electromagnetic pulse (EMP).

b. Applicability. This requirement applies per MIL-STD-461F, to equipment with external interconnecting wires and cables, for equipment which will operate on a launch vehicle or in space.

c. Requirement. The equipment shall meet the requirements of MIL-STD-461F.

d. Verification. Verification shall be by test in accordance with MIL-STD-461F, with the test signals applied to the following cables and wires.

- (1) Each and every complete cable bundle interfacing with an electrical connector on the EUT or penetrating the EUT box without a connector. This includes signal cable bundles, power cable bundles, mixed use cable bundles, individual wires using their own dedicated connectors or penetrations and individual coaxial cables using their own dedicated connectors or penetrations. *(This is a paraphrase of MIL-STD-461F procedures.)*
- (2) The power leads (including returns and neutrals) grouped together separately, for cable bundles which include power and other leads. *(This is a paraphrase of MIL-STD-461F procedures.)*
- (3) The power leads grouped together separately, but with returns and neutrals removed, for power cable bundles and for cable bundles which include power and other leads. *(This is a paraphrase of MIL-STD-461F procedures.)*
- (4) The power returns grouped together separately and the power neutrals grouped together separately, for power cable bundles and for cable bundles which include power and other leads. *(This is a new requirement not in the MIL-STD-461F procedures.)*
- (5) (1) to (4) above also apply to cable bundles or wires which are routed separately but connect to the same connector. *(This is an expansion of the MIL-STD-461F procedures.)*

(P) e. Tailoring: Shielded cables. Power cables which, in the unit operational (e.g., flight) configuration, are shielded from the power source to the unit, are exempt from subrequirements d1(2), d1(3) and d1(4), if approved by the procuring authority. Cables which contain power and other wires, all of which are completely shielded from the EUT to final loads or sources, are also exempt from subrequirements d1(2),

d1(3) and d1(4), if approved by the procuring authority. Cables which are mostly shielded may be considered for exemption from subrequirements d1(2), d1(3) and d1(4), but will need stronger justification than completely shielded cables, and will also require approval by the procuring authority.

6.32 Conducted Susceptibility, Damped Sinusoidal Transients, Cables and Power Leads, 10kHz-100MHz (CS116)

a. Purpose. The purpose of this requirement is to ensure that equipment with external cables will not operate outside specified performance limits when subjected to electromagnetic fields of damped sine waveforms from both external stimuli such as lightning and EMP and from platform electrical switching phenomena.

b. Applicability. This requirement applies per MIL-STD-461F, to equipment with external interconnecting wires and cables, for equipment which will operate on a launch vehicle or in space.

c. Requirement. The equipment shall meet the requirements of MIL-STD-461F, as modified herein.

d1. Verification: Basic. Verification shall be by test in accordance with MIL-STD-461F, and the test signals shall be applied to the following cables and wires.

- (1) Each and every complete cable bundle interfacing with an electrical connector on the EUT or penetrating the EUT box without a connector. This includes signal cable bundles, power cable bundles, mixed use cable bundles, individual wires using their own dedicated connectors or penetrations and individual coaxial cables using their own dedicated connectors or penetrations. *(This is a paraphrase of MIL-STD-461F procedures.)*
- (2) The power leads (including returns and neutrals) grouped together separately, for cable bundles which include power and other leads. *(This is a paraphrase of MIL-STD-461F procedures.)*
- (3) The power leads grouped together separately, but with returns and neutrals removed, for power cable bundles and for cable bundles which include power and other leads. *(This is a paraphrase of MIL-STD-461F procedures.)*
- (4) The power returns grouped together separately and the power neutrals grouped together separately, for power cable bundles and for cable bundles which include power and other leads. *(This is a new requirement not in the MIL-STD-461F procedures.)*
- (5) (1) to (4) above also apply to cable bundles or wires which are routed separately but connect to the same connector. *(This is an expansion of the MIL-STD-461F procedures.)*

(P) d2. Verification: Power off. Repeat the EUT testing of MIL-STD-461F, paragraph 5.15.3.4c, as modified herein, for the EUT power-off condition.

(P) e. Tailoring: Shielded cables. Power cables which, in the unit operational (e.g., flight) configuration, are shielded from the power source to the unit, are exempt from subrequirements d1(2), d1(3) and d1(4), if approved by the procuring authority. Cables which contain power and other wires, all of which are completely shielded from the EUT to final loads or sources, are also exempt from subrequirements d1(2),

d1(3) and d1(4), if approved by the procuring authority. Cables which are mostly shielded may be considered for exemption from subrequirements d1(2), d1(3) and d1(4), but will need stronger justification than completely shielded cables, and will also require approval by the procuring authority.

6.33 Radiated Emissions, (AC) Magnetic Field, 30Hz-100kHz (RE101)

a. Purpose. The purpose of this requirement is to ensure that equipment will not radiate AC magnetic fields in excess of limits which may interfere with equipment sensitive to AC magnetic fields.

b. Applicability. This requirement applies as specified by the procuring authority, to all units and subsystems which will operate on a launch vehicle or in space, when the platform may contain equipment sensitive to AC magnetic fields. (A partial list of equipment which may be sensitive to AC magnetic fields is given in paragraph 6.34d2.)

c1. Requirement: Basic, 30Hz-100kHz. The basic requirement shall be in accordance with MIL-STD-461F, except that the emissions curve shall be 20dB below the susceptibility curve of Requirement 6.36(RS101).

(P) c2. Requirement: Frequency range extension 0.1Hz-30Hz. If specified by the procuring authority, the required frequency range shall be extended down to 0.1Hz in accordance with special needs of the program. The limits shall be the same as at 30Hz, unless otherwise specified by the procuring authority.

d1. Verification. Verification shall be by test IAW MIL-STD-461F, except that the limit curve shall be 20dB below the susceptibility curve of Requirement 6.36(RS101).

(X) d2. Verification: Frequency range extension 0.1Hz-30Hz. If the extended frequency range of subrequirement c2 is specified by the procuring authority, verification in the relevant frequency ranges shall be by test using test methods and test equipment approved by the procuring authority.

(P) 6.34 Radiated Emissions, DC Magnetic Field

a. Purpose. The purpose of this requirement is to ensure that equipment will not generate DC magnetic fields in excess of limits which may interfere with equipment sensitive to DC magnetic fields.

b. Applicability. This requirement is applicable as specified by the procuring authority, for units and subsystems which will operate on a launch vehicle or in space, when the platform may contain equipment sensitive to DC magnetic fields.

c1. Requirement: Basic. Unit DC magnetic fields shall be below the sensitivities of other vehicle units in accordance with Requirement 4.3(EMISMs).

c2. Requirement: Maximum limit. Unless otherwise specified, no unit DC magnetic field shall be greater than 160dBpT at 7cm in any direction from the unit and for any orientation of the field.

d1. Verification: Basic. Verification shall be by test and analysis using methods developed by the procuring authority or developed by the contractor and approved by the procuring authority.

d2. Verification: Units sensitive to DC magnetic fields. Verification methodologies shall consider the DC magnetic sensitivities of the following equipment and any other equipment which may be sensitive to DC magnetic fields.

Magnetometers	Low energy particle detectors
Photomultipliers	Tape recorders
Electron beam devices	Magnetic memory drums
Image-dissector tubes	

d3. Verification: Sources of DC magnetic fields. Verification methodologies shall consider the DC magnetic fields of the following equipment and any other equipment which may be sources of DC magnetic fields.

DC-DC converters	Electrical current loops
Magnetic latching relays	Wiring harnesses
TWTs	Ground current paths in structure
Coax switches	Ground current paths in equipment
Transformers	Internal wiring of assemblies
Inductors	Windings of transformers and inductors
Solenoid valves	Solar array conductors
Toroids	Solenoids
Motors	Paths for currents caused by accidental thermocouples
Torque rods	Thermoelectric-induced currents in spacecraft structure
Ferrite isolators	
Circulators	
Tape recorders	
Other permanent magnetics	
	Induced magnetism in ferromagnetic materials
	Glass-to-metal hermetic seals
	Transistor cases
	Electronic component leads
	Fastener hardware
	Gears
	Bearings
	Currents induced by external fields

(Note: The limit given in paragraph c2 (160dBpT) is the same level as the 30Hz limit in Requirement 6.33c1(RE101).)

(P) 6.35 Radiated Emissions, DC Magnetic Dipole Moment

a. Purpose. The purpose of this requirement is to ensure that equipment will not generate DC magnetic dipole moments in excess of limits which may degrade space vehicle orientation stability.

b. Applicability. This requirement is applicable as specified by the procuring authority, for units and subsystems which will operate on a launch vehicle or in space, when the platform may be sensitive to torques which may result from equipment-generated dipole moments. (A partial list of equipment which may generate dipole moments is given in verification paragraph 6.34d3.)

c1. Requirement: Basic. Unit DC magnetic dipole moments shall be below levels which affect vehicle orientation in accordance with Requirement 4.3(EMISMs).

c2. Requirement: Maximum limit. Unless otherwise specified, no unit DC magnetic dipole moment shall be greater than $0.01\text{A}\cdot\text{m}^2/\text{kg}$ for units manifested on non-spinning vehicles, or greater than $0.004\text{A}\cdot\text{m}^2/\text{kg}$ for units manifested on spinning vehicles.

d1. Verification: Basic. Verification shall be by test and analysis using methods developed by the procuring authority or developed by the contractor and approved by the procuring authority.

d2. Verification: Sources of DC magnetic dipole moments. Verification methodologies shall consider the DC magnetic dipole moments of the equipment listed in paragraph 6.34d3(Sources of DC magnetic fields) and any other equipment which may be sources of DC magnetic dipole moments.

(Note: The limits given in paragraph c2 ($0.01\text{A}\cdot\text{m}^2/\text{kg}$ and $0.004\text{A}\cdot\text{m}^2/\text{kg}$) are those given in NASA SP-8018 (Reference 1 of paragraph 2.3.4 of this document), Table IV, for Class III magnetic properties control. These are the largest limits provided in the table.)

6.36 Radiated Susceptibility, (AC) Magnetic Field, 30Hz-100kHz (RS101)

a. Purpose. The purpose of this requirement is to ensure that equipment will not operate outside specified performance limits when subjected to AC magnetic fields.

b. Applicability. This requirement applies as specified by the procuring authority, to all units and subsystems which will operate on a launch vehicle or in space and may be sensitive to AC magnetic fields. (A partial list of equipment which may be sensitive to AC magnetic fields is given in verification paragraph 6.34d2.)

c1. Requirement: Basic, 30Hz-100kHz. The basic requirement shall be in accordance with MIL-STD-461F, except that the susceptibility limits shall be those from MIL-STD-461F, Figure RS101-2 (RS101 limit for all Army applications).

(P) c2. Requirement: Frequency range extension 0.1Hz-30Hz. If specified by the procuring authority, the required frequency range shall be extended down to 0.1Hz in accordance with special needs of the program. The limits shall be the same as at 30Hz, unless otherwise specified by the procuring authority.

d1. Verification. Verification shall be by test in accordance with MIL-STD-461F, as modified by this requirement.

(X) d2. Verification: Frequency range extension. If the extended frequency range of subrequirement c2 is specified by the procuring authority, verification in the relevant frequency ranges shall be by test using test methods and test equipment approved by the procuring authority.

d3. Verification: Dwell times. Dwell times shall be long enough for equipment response to occur and be observed, or 3seconds, whichever is greater.

6.37 Radiated Susceptibility, Magnetic and Electric (Induction) Fields, Spikes and Power Frequencies (RS02)

a. Purpose. The purpose of this requirement is to ensure that equipment will not operate outside specified performance limits when subjected to induced transient and power frequency electromagnetic fields.

b. Applicability. This requirement applies to all units and subsystems which will operate on a launch vehicle or in space.

c1. Requirement: Spikes. The unit shall not exhibit any malfunction, degradation of performance, or deviation from specified indications, beyond the tolerances indicated in the individual equipment or subsystems specification, when subjected to test spikes having the waveforms shown in Figure 6.12c1-1. The values of $E_{()}$ and $t_{()}$ shall be:

$$E_{()} = \pm 200 \text{ volts}, \quad t_{()} = 10 \text{ microseconds } \pm 20\%.$$

(L) c2. Requirement: Power frequency. The unit shall not exhibit any malfunction, degradation of performance, or deviation from specified indications, beyond the tolerances indicated in the individual equipment or subsystem specification, when 20 amperes are applied to the test wire at the power frequencies of the UUT.

d. Verification. Verification shall be by test in accordance with the following test method.

d.1 Apparatus. The test apparatus shall consist of the following:

d.1.1 Spike Generator. The spike generator shall be as specified in Requirement 6.12(CS06) or as approved by the procuring authority.

d.1.2 Step-down Transformer and Variac. The step-down transformer and variac shall be capable of carrying the currents required by this test.

d.2 Test Setup and Procedures.

d.2.1 Cable Susceptibility Test (Test 1).

Each wire bundle shall be composed of flight-like wires whose lengths are their lengths in the actual installation or 1.5m, whichever is less.

Tape two current-carrying insulated wires to each wire bundle in the test setup with the current-carrying wires around the wire bundle, spiraling at two turns per meter (but at least 3 turns, and equally spaced in any case) and running the entire length of the bundle to within 15cm of each end connector. (See Figure 6.37d-1.)

d.2.1.1 Power Frequency Test. Make the test setup as shown in Figure 6.37d-1(a). Apply the required current at the test sample power frequencies to one test wire at a time, and monitor for susceptibility.

d.2.1.2 Spike Test. Make the test setup as shown in Figure 6.37d-1(b). Apply the required spike to one test wire at a time, and monitor for susceptibility.

d.2.2 Case Susceptibility Test (Test 2).

Wrap several turns of insulated wire around each case in the test sample. These turns should be located as shown in Figure 6.37d-2 (but at least 3 turns, equally spaced) and held in place by tape.

d.2.2.1 Power Frequency Test. Make the test setup as shown in Figure 6.37d-2(a). Apply the required current at the test sample power frequencies to one test wire at a time, and monitor for susceptibility.

d.2.2.2 Spike Test. Make the test setup as shown in Figure 6.37d-2(b). Apply the required spike, and monitor for susceptibility.

d.3 Notes.

d.3.1 AC power input and output leads are exempt from the cable test.

d.3.2 It is not the intention of the cable test to test individual wires, but to test groups or bundles of wires.

d.3.3 Keep current-carrying wires 15cm away from cable connectors.

d.3.4 All cables should be at least 5cm above the ground.

d.3.5 In order to minimize test time, test as many boxes and wire bundles at the same time as practical.

d.3.6 The power frequency used for test purposes is that frequency used in the operational system.

e. Tailoring: Power frequency. The power frequency tests are applicable only to AC power systems.

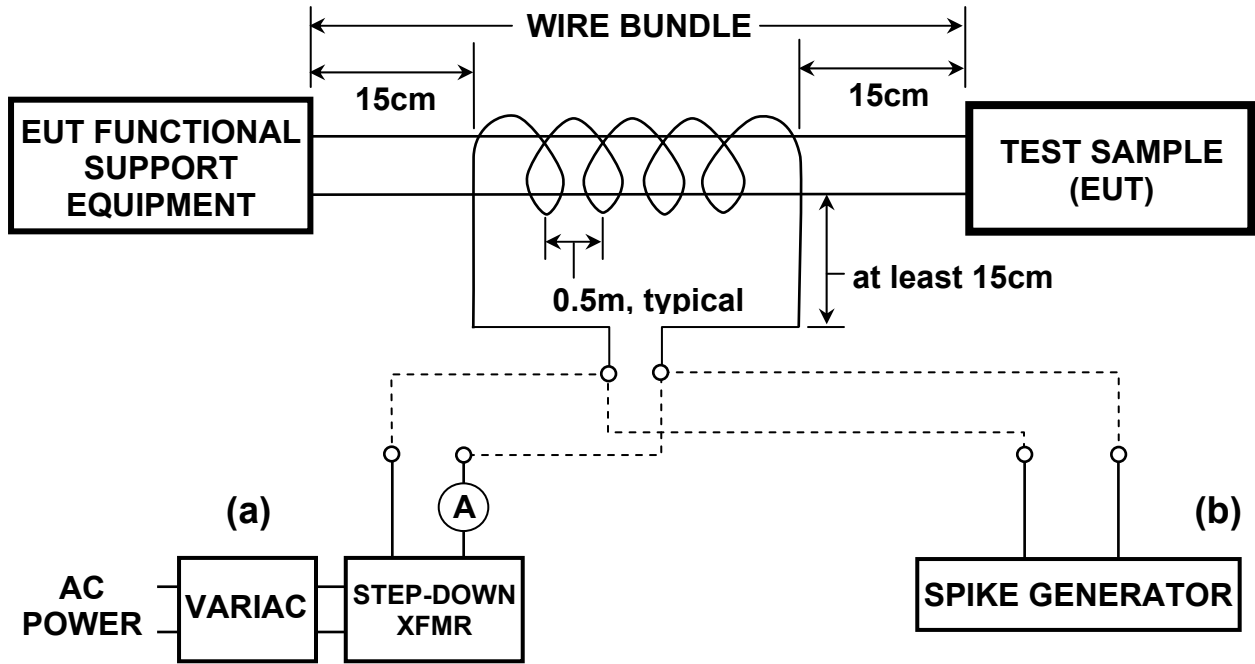

Figure 6.37d-1. Cable Test Setup (RS02).

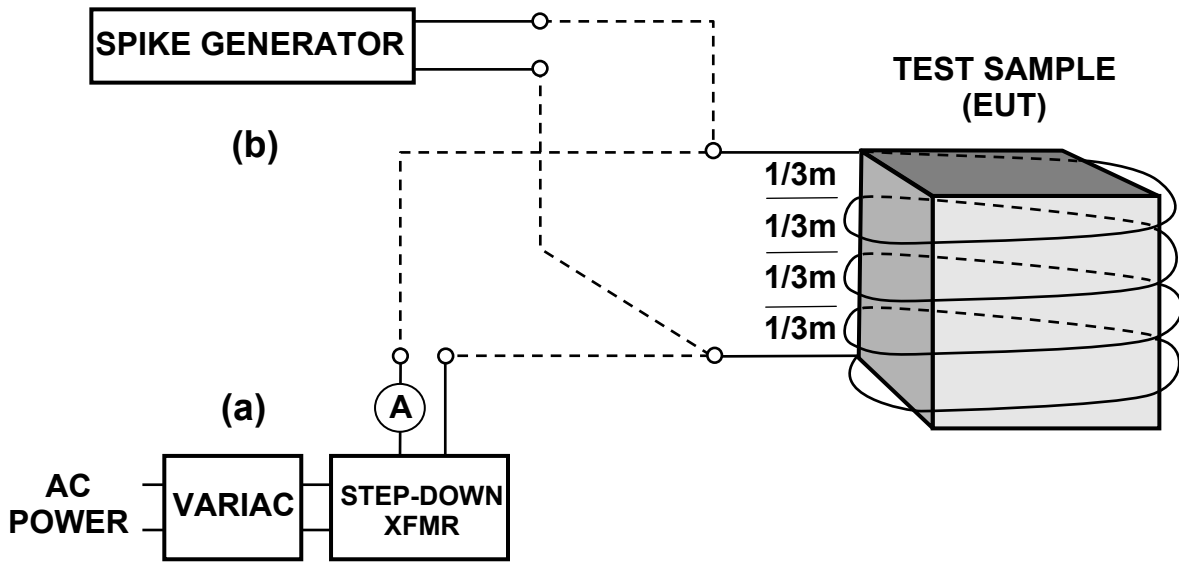

Figure 6.37d-2. Case Test Setup (RS02).

6.38 (Reserved)

6.39 (Reserved)

PASSIVE INTERMODULATION AND ENVIRONMENTS, SPACE EQUIPMENT

6.40 Passive Intermodulation (PIM), General

a. Purpose. The purpose of this requirement is to ensure that RF transmissions from on-board or external transmitters, when incident on vehicle equipment, do not result in unintentional signals as a result of passive intermodulation (PIM), which can interfere with on-board receivers.

b. Applicability. This requirement applies to all equipment on vehicles whose transmitter frequencies, receiver frequencies and operational scenarios are such that they present a PIM interference risk to vehicle operations. *(Paragraph e1(Exemption) provides an exemption from this requirement any time during the procurement, if approved by the procuring authority.)*

c1. Requirement: Thermal blankets. Thermal blankets shall not generate PIM.

c2. Requirement: Braided metallic materials. Braided metallic materials shall not generate PIM.

c3. Requirement: Electrical bonds. No equipment or vehicle electrical bond shall have a resistance within the range of 0.1ohm and 500kohm. *(Same as subrequirement 7.3c1(Vehicle PIM, Electrical bonds).)*

c4. Requirement: Incidental contacts. No incidental contact between conductors and/or semiconductors shall have a resistance within the range of 0.1ohm and 500kohm. This applies to, but is not limited to, latches, hinges, covers, fasteners and cable outer covers.

c5. Requirement: Semiconductor devices. Semiconductor devices shall not be exposed to RF transmitter emissions from on-board or external sources in excess of 250mV/m in frequency ranges which represent a PIM threat.

(Note: The specified field strength is the result of an analysis of worst-case experimental data at approximately 250MHz combined with information from a literature review, with an added 6dB of margin for multiple sources and 12dB EMISM for all other contingencies. The analysis employed a target receiver notch of 20dBuV/m, and did not account for space loss or gain of target antennas (assumed isotropic).)

d. Verification. Verification shall be by test of the equipment and materials given in the requirements, using flight-like antennas, transmitters representative of the RFI sources of concern, and by standard measurement methods of electrical bonds, as appropriate and as approved by the procuring authority.

e1. Tailoring: Exemption. Vehicles for which analysis demonstrates no risk from PIM products up to and including the seventh order of intermodulation products are exempt from these requirements, but only if approved by the procuring authority.

(Note: This tailoring provides guidance to the procuring authority for imposition of PIM requirements on a program contract. It also applies to a program for which PIM requirements have been contractually imposed by this document, but for which the contractor later seeks exemption because of a lack of necessity.)

(P) e2. Tailoring: Test frequencies. Test frequencies may be limited to source frequencies which may result in intermodulation products up to and including the seventh order of intermodulation products, if approved by the procuring authority.

(P) e3. Tailoring: RF-shielded vehicle structure. Equipment within a vehicle structure which serves as an RF shielded enclosure is exempt from this requirement if the RF field levels within the enclosure are insufficient to generate PIM. (In most cases, a shielded enclosure whose proven attenuation is no less than 40dB over all source frequencies with the potential to generate PIM will be sufficient.)

The RF attenuation of the shielded enclosure shall be demonstrated by test of the actual vehicle or a representative mock-up which includes representative worst-case penetrations, joints, cable entries, etc.

This exemption does not apply to equipment outside of the vehicle structure, nor does it apply to equipment within shielded enclosures for which the RF attenuation has not been adequately demonstrated to be sufficient, as determined by the procuring authority.

(Note: Vehicle structures will probably not have the necessary attenuation if they have any of the following characteristics:

(a) insufficient basic material attenuation,

(b) untreated apertures (including RFI-ungasketed joints) whose greatest dimension is greater than one-half wavelength of the highest source frequency of interest, or

(c) cable penetrations using unshielded cables or shielded cables which do not employ bulkhead connectors and circumferential low impedance bonding of the cable shield to the vehicle structure.)

6.41 Passive Intermodulation (PIM), Conducted RF Paths to RF Interfaces

a. Purpose. The purpose of this requirement is to ensure that passive equipment in the conducted RF paths from transmitters to antennas or from antennas to receivers do not generate unintentional signals as a result of passive intermodulation (PIM), which can interfere with on-board receivers.

b. Applicability. This requirement applies to all passive equipment in the conducted RF paths from transmitters to antennas or from antennas to receivers, on flight vehicles whose transmitter frequencies, receiver frequencies and operational scenarios are such that they present a PIM interference risk to vehicle operations. *(Paragraph e1(Exemption) provides an exemption from this requirement any time during the procurement, if approved by the procuring authority.)*

c. Requirement. Each passive component in the conducted RF paths from transmitters to antennas or from antennas to receivers, including antennas, shall not generate PIM levels which, when combined, are greater than 12dB below receiver sensitivities.

d. Verification. Verification shall be by test of each component or string of components, using operational-like RF signals. The combined PIM levels for the conducted RF paths may be verified by analysis using the test results of individual

components or strings of components, but the requirement for the entire string of components in each path shall be verified by test at the earliest availability of the components. Requirement 6.25(CE106) may be used as test guidance, with the actual tests and analyses performed in accordance with procedures approved by the procuring authority.

e1. Tailoring: Exemption. Vehicles for which analysis demonstrates no risk from PIM products up to and including the seventh order of intermodulation products are exempt from these requirements, but only if approved by the procuring authority.

(Note: This tailoring provides guidance to the procuring authority for imposition of PIM requirements on a program contract. It also applies to a program for which PIM requirements have been contractually imposed by this document, but for which the contractor later seeks exemption because of a lack of necessity.)

(P) e2. Tailoring: Test frequencies. Test frequencies may be limited to source frequencies which may result in intermodulation products up to and including the seventh order of intermodulation products within receiver passbands, if approved by the procuring authority.

6.42 Electrostatic Discharge (ESD), Surface Materials

a. Purpose. The purpose of this requirement is to reduce the risk that units and subsystems will deviate from their specified performance as a result of the electromagnetic effects of ESD.

b. Applicability. This requirement applies to all equipment on a space vehicle, including cables, blankets and all other equipment which is exposed to on-orbit atmospheric or space electrical charging environments. This requirement does not apply to launch vehicle equipment. (See Requirement 7.4(Triboelectric Charging, Launch Vehicles).)

c1. Requirement: Uncoated bulk materials. The volume resistivity of an uncoated bulk material shall not exceed 10^9 ohm-cm.

c2. Requirement: Partially conductive surface coating on conductor. The volume resistivity of a partially conductive surface (e.g., paint) on a grounded conductive substrate shall not exceed 2×10^9 ohm-cm²/d, where d is the surface thickness of the coating in cm. If the thickness is not known during design development, a maximum volume resistivity of 10^{11} ohm-cm may be used.

c3. Requirement: Partially conductive surface coating on insulator. The surface resistivity of a grounded partially conductive surface coating on a dielectric substrate shall not exceed 10^8 ohm/square.

c4. Requirement: Two partially conductive surface coatings on insulator. The volume resistivity of an outer partially conductive surface (e.g., paint), which is on an inner partial conductor, which is on a dielectric substrate, shall not exceed 10^{12} ohm-cm, and the coating thickness shall not exceed 0.005inches. The surface resistivity of the inner partial conductor shall not exceed 5×10^7 ohm/square.

d. Verification. Verification shall be by test of the material under space conditions (vacuum baked-off, vacuum, temperature) or by inspection of material vendor specification sheets demonstrating test results under space conditions.

(P) e. **Tailoring.** Materials which are within an enclosure that reduces the charging environment to no greater than 10^{-14} ampere/cm² are exempt from this requirement. The adequacy of the enclosure shall be verified by an analysis approved by the procuring authority. The analysis shall consider the enclosure materials, enclosure openings, the plasma environments, the vehicle configuration and the vehicle orientation and velocity.

6.43 Electrostatic Discharge (ESD), Susceptibility

a. **Purpose.** The purpose of this requirement is to ensure that equipment will not deviate from its specified performance during or after exposure to the electromagnetic effects of ESD.

b. **Applicability.** This requirement applies to all units and subsystems which will operate in space, and their cables. This requirement does not apply to launch vehicle equipment. (See Requirement 7.4(Triboelectric Charging, Launch Vehicles).)

c1. **Requirement: Air discharge (indirect discharge).** The unit or subsystem, while in its expected operational configuration, shall operate without deviation from its specified performance while an electric arc per IEC 61000-4-2 Level 4 is discharged 30centimeters from each unit surface not bonded to a vehicle ground plane and 30centimeters from each unit cable, at a pulse rate of 1pulse per second for a period of 30seconds at each location.

c2. **Requirement: Contact discharge (direct discharge).** The unit or subsystem, while in its expected operational configuration, shall operate without deviation from its specified performance while an electric arc per IEC 61000-4-2 Level 4 is discharged directly to each unit corner not bonded to a vehicle ground plane, at a pulse rate of 1pulse per second for a period of 30seconds at each location.

c3. **Requirement: Vehicle mounting surface discharge.** The unit or subsystem, while in its expected operational configuration, shall operate without deviation from its specified performance while an electric arc per IEC 61000-4-2 Level 4 is discharged through the unit vehicle mounting surface, at a pulse rate of 1pulse per second for a period of 30seconds.

d. **Verification.** Verification shall be by test in accordance with IEC 61000-4-2 except as superseded by this document. The test setup shall simulate the operational wiring and grounding scheme. The test sample shall be bonded to the ground plane by the same method used for the vehicle installation.

(P) e1. **Tailoring: Contact discharge.** Units or subsystems which are within a vehicle structure that reduces the charging environment to 10^{-14} ampere/cm² or less are exempt from the contact discharge subrequirement (c2), but only if the adequacy of the enclosure is verified by a method approved by the procuring authority. As a minimum, the verification method shall consider the structure materials, structure openings, the plasma environments, the vehicle configuration and the vehicle orientation and velocity.

However, this exemption does not apply to equipment with interface wiring exiting the shielded volume, where the interface wiring is unshielded or the wire shield is

not circumferentially bonded to the volume shield with a DC resistance of less than 2.5mohm.

(P) e2. Tailoring: Air discharge. Units or subsystems which meet the tailoring constraints of e1 and which are within an RF-shielded vehicle structure providing at least 40dB of RF attenuation from 10kHz to 1GHz, are exempt from the air discharge requirement (c1). The RF attenuation shall be demonstrated by testing the actual vehicle or a representative mock-up which includes representative worst-case penetrations, joints, cable entries, etc. (See Note 1.)

However, this exemption does not apply to equipment with interface wiring exiting the shielded volume, where the interface wiring is unshielded or the wire shield is not circumferentially bonded to the volume shield with a DC resistance of less than 2.5mohm.

(Notes:

(1) *Vehicle structures will probably not have the necessary attenuation if they have the following characteristics:*

(a) *insufficient basic material attenuation,*

(b) *untreated apertures (including RFI-ungasketed joints) whose greatest dimension is greater than 3inches,*

(c) *cable penetrations using unshielded cables or shielded cables which do not employ bulkhead connectors and circumferential low impedance bonding of the cable shield to the vehicle structure.*

(2) *This requirement is a default requirement to be used until a new standard dedicated to ESD can be developed to comprehensively address ESD requirements for space and launch equipment during launch and on orbit.*

(3) *No exemption is given for mounting surface discharge, since arc currents generated elsewhere may flow through the unit ground plane. In addition, unit electrical isolation from the ground plane may not provide adequate protection from arc-induced voltages capacitively coupling to the unit.)*

(4) *MIL-STD-1541A required equipment to be tested for air discharge plus either contact discharge (for "equipment exposed to the direct space environment") or mounting surface discharge (for "equipment installed within a shielded space vehicle").)*

(P) 6.44 Bulk Charging

(This requirement will be included in a future version of this document.)

(P) 6.45 EMP (RS105)

a. Purpose. The purpose of this requirement is to reduce the risk that units and subsystems will deviate from their specified performance as a result of the electromagnetic effects of EMP.

b. Applicability. When imposed by the procuring authority, this requirement applies to units and subsystems which will operate on a launch vehicle or in space, outside of a well-shielded enclosure, but excludes the effects of coupling through the equipment interface cables.

c. Requirement. The equipment shall meet the requirements of MIL-STD-461F, RS105.

d. Verification. Verification shall be by test in accordance with MIL-STD-461F, RS105.

(L) 6.46 Multipaction

a. Purpose. The purpose of this requirement is to ensure that equipment will not experience multipaction during its service life.

b. Applicability. This requirement applies to all units and subsystems which will process or transfer high levels of RF power in the vacuum of space.

c. Requirement. Units and subsystems shall be free of multipaction during their service lives.

d. Verification. Verification shall be by analysis or test in accordance with ECSS-E-20-01A, paragraphs 4.4, 4.5, 5.1-5.6, 6.2-6.6.4, 7.1-7.3.2, 8.1-8.4.2, Annex B, Annex D and Annex E, except as superseded by this document. In addition, documentation requirements in ECSS-E-20-01A (test plans and procedures) do not apply, and margin requirements therein are superseded by the margin requirements of this document (Requirement 4.3(EMISMs): 6dB acceptance, 12dB qual, 18dB analysis only).

Alternative verification methodologies may be used if approved by the procuring authority.

(P) 6.47 Corona

(This requirement will be included in a future version of this document.)

(P) 6.48 Lightning

a. Purpose. The purpose of this requirement is to ensure that equipment will continue to meet all performance specifications after a lightning strike.

b. Applicability. This requirement, as tailored, applies to all units and subsystems.

c1. Requirement: Induced transient susceptibility. The equipment shall meet the requirements of RTCA/DO-160, Section 22.

c2. Requirement: Direct effects. The equipment shall meet the requirements of RTCA/DO-160, Section 23.

d. Verification. Verification shall be in accordance with RTCA/DO-160.

e1. Tailoring: General. Tailoring shall be by the procuring authority or in accordance with a contractor plan as approved by the procuring authority. (Tailoring should consider the launch site, facility lightning protection systems, location of the equipment within or on the vehicle, the vehicle structure (including payload fairing), possible launch environments and other factors.)

For example, all equipment should be able to survive the requirements of c1 (induced). The levels may be tailored depending on location and interfaces. For instance, payload equipment within a protective cover (metallic fairing or other RF shield) and with no interfaces outside might have less stringent levels. Equipment

outside a protective cover, especially connected to cables, would have the most stringent requirements.

At the other end of the spectrum, equipment which may have to launch in inclement weather should be able to operate through (meet specification during) the most stringent levels of subrequirements c1 and c2.

e2. Tailoring: Alternative requirements. While it may result in less robust equipment, consideration may be given to developing an integrated complement of alternative requirements, such as phenomenon monitoring at the system level, unit retest criteria and unit retest capability.

(Note: This requirement is a default requirement to be used until requirements more specific to space systems can be developed.)

6.49 (Reserved)

POWER ISOLATION AND GROUNDING, SPACE EQUIPMENT

6.50 (Reserved)

6.51 Power Isolation and Grounding

a. Purpose. The purpose of this requirement is to ensure that equipment isolation and grounding are adequate to provide vehicle EMC.

b. Applicability. This requirement applies to all equipment (units and subsystems) which will operate on a launch vehicle or in space.

c1. Requirement: Primary power isolation from chassis. Any unit which receives primary power shall provide primary power isolation from chassis of at least 1megohm.

c2. Requirement: Primary power isolation from telemetry. Any unit which receives primary power shall provide primary power isolation from telemetry of at least 1megohm.

c3. Requirement: Secondary power referencing. Secondary power shall be referenced to spacecraft structure at one location only. Except for that location, secondary power shall be isolated from spacecraft structure by at least 1megohm.

c4. Requirement: Secondary power isolation from primary power. Any unit which receives primary power and generates secondary power shall provide isolation between primary and secondary power within the unit of at least 1megohm.

c5. Requirement: Bonding to vehicle structure. Each unit shall have provision for electrically bonding its case (container) to the vehicle structure, either directly or via its subsystem or payload structure.

d1. Verification: Isolation. Verification of subrequirements c1 to c4 shall be by test using standard methods as approved by the procuring authority.

d2. Verification: Bonding. Verification of subrequirement c5 shall be by inspection.

- (P) e1. Tailoring: Power return on vehicle structure.** Units which will be used on a vehicle whose design intentionally returns power on the vehicle structure may be exempted from subrequirements c1, c3 and c4, if approved by the procuring authority.
- (P) e2. Tailoring: Secondary power referencing.** Where secondary power is entirely confined to a single unit, that unit may be exempted from subrequirement c3, if approved by the procuring authority.

7. DETAILED REQUIREMENTS, SPACE VEHICLES

7.1 Vehicle EMC

a. Purpose. The purpose of this requirement is to ensure the intrasystem and intersystem EMC of vehicles with the EMISMs required by Requirement 4.3(EMISMs).

b. Applicability. This requirement applies to the vehicle in all RFI environments and configurations, over its entire service life. Also see Subrequirement 4.1c3(Unit General Requirements, Environments).

c1. Requirement: Basic. No unit, subsystem or system shall deviate from its specified performance due to the electromagnetic effects of any other unit, subsystem or system, while all equipment is configured and operated in all operational configurations and modes, and while all equipment is exposed to the external environment defined in Requirement 6.27(RS103), except as otherwise specified in this document. This requirement applies over the entire service lives of the equipment (Requirement 4.4(Service Life)).

c2. Requirement: EMISMs. All EMC interfaces shall meet Requirement 4.3(EMISMs).

d1. Verification: Basic. Verification shall be by vehicle-level test and analysis using methods developed by the contractor and approved by the procuring authority, within the constraints given herein.

d2. Verification: Self-compatibility. The vehicle shall be tested for self-compatibility

- 1) In its full-up configuration
- 2) With all equipment deployed (including solar arrays (SAs))
- 3) With all equipment operating
 - including transmitters with hats off
 - including monitored operational uplinks at minimal mission link margin
- 4) In all operational modes
- 5) For all operational frequencies.

All critical operations shall be monitored for susceptibilities, including, but not limited to, all uplinks, downlinks and critical circuits.

Table 7.1d2-1 summarizes some of the details of the configurations for the various tests of this requirement.

d3. Verification: Self-compatibility and EMISMs, conducted regime. During the self-compatibility tests (d2), time and frequency conducted emissions on the power lines and critical circuits shall be monitored and recorded to provide data necessary to determine EMISMs in the conducted regime (when combined with equipment susceptibilities).

d4. Verification: Self-compatibility and EMISMs, radiated emissions. During the self-compatibility tests (d2), e-field and h-field radiated emissions external to the vehicle shall meet the requirements of Requirements 6.24(RE102),

6.33(RE101), 6.34(DC Magnetic Field), 6.35(DC Magnetic Dipole Moment) and 4.3(EMISMs), as specified for the program.

Table 7.1d2-1. Some Vehicle Test Configuration Parameters

Test Para.	Appli- cability	Determine EMISM	Active Uplink	Rx Ant. hats	Tx Ant. hats	Ext. RF (RS103)	Com- bine w/
d1 Basic	A	N/A	N/A	N/A	N/A	N/A	N/A
d2 Self- compat.	A	no	yes	off	off	optional	N/A
d3 CE	A	yes	optional	optional	optional	optional	d2
d4 RE	A	yes	yes	off	optional	optional	d2
d5 RS	A	if fail	yes	off	off	yes	d2
d6 Ordnance	A	yes	optional	optional	off	yes	d5
d7 PIM	P	yes	yes	off	off	optional	d2
d8 CE w/ RS	P	yes	optional	optional	optional	yes	d5
d9 PIM w/ RS	P	yes	yes	off	off	yes	d5,d7

d5. Verification: External RFI compatibility (RS103) and EMISMs. During the self-compatibility tests (d2), the vehicle shall be illuminated per Requirement 6.27(RS103) as tailored for the program, and all units, subsystems and systems shall function within specification.

Susceptibilities shall be thresholded per MIL-STD-461F para. 4.3.10.4.3.

d6. Verification: Ordnance EMISMs, with external RFI (RS103). During the external RFI compatibility tests (d5), the EMISM (see Requirement 4.3(EMISMs) of each ordnance subsystem, as integrated into the vehicle, shall be verified. The EED shall be replaced by an EED simulator for test purposes. Candidate simulators are optical simulators, electrical simulators (e.g., a sensing resistor voltage into an amplifier) and fuse simulators (fusing at 20dB below the EED no-fire level).

(P) d7. Verification: Self-compatibility and EMISMs, PIM. During the self-compatibility tests (d2), electric field radiated emissions and PIM products shall meet the requirements of Requirements 6.24(RE102) and 4.3 (EMISMs) for the program.

(P) d8. Verification: Conducted emissions and EMISMs, with external RFI (RS103). During the external RFI compatibility tests (d5), time- and frequency-domain conducted emissions on the power lines and critical circuits shall be monitored and recorded to provide data necessary to determine EMISMs in the conducted regime (when combined with equipment susceptibilities).

(P) d9. Verification: PIM and EMISMs, with external RFI (RS103). During the external RFI compatibility tests (d5), e-field radiated emissions shall be monitored and recorded to provide data necessary to determine EMISMs of PIM interference with receivers (when combined with equipment susceptibilities and sensitivities).

(Note: PIM interference due to external sources will be of very short duration, unless the SC is tracked. Even if tracked, the interference will peak over a fairly short duration. For this reason, on-board sources are the greater threat. Furthermore, if PIM at unacceptable frequencies and levels is generated during the tests, an analysis should be performed to determine if there are identified external threats capable of transmitting field strengths adequate to generate the offending PIM.)

(P) d10. Verification: Secondary power. Secondary power shall be subject to all of the power conducted interface requirements of this document, if the power is serving multiple loads.

d11. Verification: Unit-level test methods. The test methods, test equipment parameters, limits and frequency ranges required for the unit-level tests of this document shall be employed for the respective verification paragraphs of this Requirement, where practicable.

e1. Tailoring: Program classes. All programs classes shall be verified by test.

e2. Tailoring: Combining RFI susceptibility (RS103) test levels. In performing the external RFI susceptibility tests, different RFI envelopes apply to different phases of development and operations. In the interest of reducing test time, an overall worst-case envelope may be developed from the individual envelopes and applied only for an operational system. In other words, testing to higher levels when equipment is not operational and lower levels when equipment is operational may be combined into a single test at the higher levels with all equipment operational. In performing such a combined test, test levels shall start below the lower levels and be raised up to the higher levels, noting lowest susceptibility levels for operational requirements, and proceeding to the higher levels to determine if survival is a problem there. If risk of damaging the equipment at the higher levels develops, the test may be halted and redone (for survival alone) at the higher levels with the equipment off.

(P) e3. Tailoring: PIM. Vehicle-level PIM verification is not required for programs for which analysis demonstrates no risk from PIM products up to and including the seventh order of intermodulation products, but only if the analysis is approved by the procuring authority.

(Note: This tailoring provides guidance to the procuring authority for imposition of PIM requirements on a program contract. It also applies to a program for which PIM requirements have been contractually imposed by this document, but for which the contractor later seeks exemption because of a lack of necessity.)

e4. Tailoring: Radiated regime frequency ranges. Vehicle-level radiated regime verification frequency ranges shall envelop equipment-level frequency ranges.

(P) e5. Tailoring: Reduced e-field emissions (RE102) frequency ranges. For payloads, the e-field emissions (RE102) frequency test ranges may be limited to platform (payload, launch vehicle and intermediate stage) passbands plus LNA BWs +/- 10% of the passband center frequency. *(The full frequency range applies to launch vehicles and intermediate stages, since they are used for various payloads.)*

e6. Tailoring: Radiated regime BWs. Vehicle-level radiated regime verification BWs shall envelop equipment-level BWs. In general, the BWs shall be no less than those employed for the equipment level testing.

e7. Tailoring: Radiated regime dwell times. Vehicle-level radiated regime verification dwell times shall envelop equipment-level dwell times. For all vehicle transmit frequencies, the verification dwell time shall be 20minutes. For all other radiated susceptibility frequencies, dwell time shall be long enough for system response to occur and be observed, or 3seconds, whichever is greater.

(P) e8. Tailoring: Equipment deployment. Where it is not practicable to deploy components, such as SAs, an alternative test configuration simulating the non-deployed components may be proposed for approval by the procuring authority. (See notes below.)

(P) e9. Tailoring: Combining tests. Tests described in paragraphs d1-d10 may be combined where practical and approved by the procuring authority.

(P) e10. Tailoring: Secondary power. The limits of power interface requirements for secondary power shall be tailored in accordance with the power quality of the power line and the emissions characteristics of the loads, but not the load robustness, as approved by the procuring authority.

(P) e11. Tailoring: Unit-level test methods. Unit-level test methods may not always be the best methods to use at the vehicle level. Improvements are encouraged to be proposed for approval by the procuring authority.

(Notes:

(Various logistic and safety problems present for the deployment of some equipment for some vehicles. This is particularly true for solar arrays (SAs), so the following notes discuss them and options for “test-like-you-fly” vehicle-level testing.

(During vehicle EMC testing, with regard to the SAs, the following phenomena are possible concerns, in the following order:

- (1) Radiated emissions from the SA wiring while the SC power system is operating, causing interference with SC RF receivers.*
- (2) Reflection of SC RF transmissions off of the SAs back to the SC, causing interference with SC equipment.*
- (3) Passive Intermodulation (PIM) from the SAs due to RF from the SC transmitters, causing interference with SC RF receivers.*

(For vehicle radiated emissions (RE) testing, a high fidelity simulation would be the use of panels simulating the SAs. The panels should emulate the SAs as closely as possible (the wiring and the panel itself), except that they would lack the solar cells. During the vehicle radiated emissions test, the panel wiring would be connected to the SC SA port and the panels would be positioned as close to as flown as practicable, making sure that the panel did not shadow any panel wiring emissions from the test antennas. The SA wiring would be powered by a solar array simulator, driving power through the panels into the SC, to exercise the vehicle power electronics.

(This is not as accurate as using the actual SAs attached to the SC for obvious reasons, including the material of the panels, the locations of the panels, and the fact that RF leakage from penetrations at the SA attachment may not be realistic.

(Another, although less accurate, alternative, is to simply use flight-like SA cabling connected to the SA port and driven by the solar array simulator. This would obviate the need to construct simulated panels.

(Item 2 above, RF reflections off of the SA, is usually a lesser concern than RE. If it is a concern, however, testing can be performed with RF reflective panels positioned like the operational SAs. However, they would not have to be wired or powered.

(If PIM (item 3 above) is a concern, a panel built like the SAs and containing the same type solar cells needs to be included in the system test, positioned somewhat like the SAs, but especially to receive the maximum power from the SC transmitters, which need to be powered at maximum power through the antennas. However, the panels would not have to be connected to the SC or powered.

(As an example of the benefit of test-like-you-fly, a recent program manifested a science mission with a set of highly sensitive receivers, employing antennas on a boom and optimized to pick up frequencies over a wide spectrum at very low field strengths.

(Testing the vehicle with the solar arrays deployed revealed that the solar arrays produced low frequency conductive noise caused by solar array string switching, which radiated at high enough levels to interfere with the sensitive receivers. In fact, the emissions ICD requirements were not met by at least two orders of magnitude. Mitigation included design changes and operational work-arounds.

(Without test-like-you-fly EMI testing with the solar arrays, the mission would have been severely degraded, if not a total failure.)

7.2 (Reserved)

7.3 Vehicle Passive Intermodulation (PIM)

a. Purpose. The purpose of this requirement is to ensure that RF transmissions from on-board or external transmitters, when incident on vehicle equipment, do not result in unintentional signals as a result of passive intermodulation (PIM), which can interfere with on-board receivers.

b. Applicability. This requirement applies to all platforms whose transmitter frequencies, receiver frequencies and operational scenarios are such that they present a PIM interference risk to vehicle operations. *(Paragraph e1(Exemption) provides an exemption from this requirement any time during the procurement, if approved by the procuring authority.)*

c1. Requirement: Electrical bonds. No equipment or vehicle electrical bond shall have a resistance within the range of 0.1ohm and 500kohm. *(Same as subrequirement 6.40c3(Equipment PIM, Electrical bonds).)*

c2. Requirement: Incidental contacts. No incidental contact between conductors and/or semiconductors shall have a resistance within the range of 0.1ohm and 500kohm. This applies to, but is not limited to, fasteners and cable outer covers.

c3. Requirement: Semiconductor devices. Semiconductor devices shall not be exposed to RF transmitter emissions from on-board or external sources in excess of 250mV/m in frequency ranges which represent a PIM threat.

(Note: The specified field strength is the result of an analysis of worst-case experimental data at approximately 250MHz combined with information from a literature review, with an added 6dB of margin for multiple sources and 12dB EMISM for all other contingencies. The analysis employed a target receiver notch of 20dBuV/m, and did not account for space loss or gain of target antennas (assumed isotropic).)

d. Verification. Verification shall be by test, using flight-like antennas, transmitters representative of the RFI sources of concern, and standard measurement methods of electrical bonds, as approved by the procuring authority.

(P) e1. Tailoring: Exemption. Vehicles for which analysis demonstrates no risk from PIM products up to and including the seventh order of intermodulation products are exempt from these requirements, but only if the analysis is approved by the procuring authority.

(Note: This tailoring provides guidance to the procuring authority for imposition of PIM requirements on a program contract. It also applies to a program for which PIM requirements have been contractually imposed by this document, but for which the contractor later seeks exemption because of a lack of necessity.)

(P) e2. Tailoring: Test frequencies. Test frequencies may be limited to source frequencies which may result in intermodulation products up to and including the seventh order of intermodulation products, as approved by the procuring authority.

(P) e3. Tailoring: RF-shielded vehicle structure. Equipment within a vehicle structure which serves as an RF shielded enclosure is exempt from this requirement if the RF field levels within the enclosure are insufficient to generate PIM. (In most cases, a shielded enclosure whose attenuation is no less than 40dB over all source frequencies with the potential to generate PIM will be sufficient.)

The RF attenuation of the shielded enclosure shall be demonstrated by test of the actual vehicle or a representative mock-up which includes representative worst-case penetrations, joints, cable entries, etc.

This exemption does not apply to equipment outside of the vehicle structure, nor does it apply to equipment within shielded enclosures for which the RF attenuation has not been adequately demonstrated to be sufficient, as determined by the procuring authority.

(Note: Vehicle structures will probably not have the necessary attenuation if they have any of the following characteristics:

(a) insufficient basic material attenuation,

(b) untreated apertures (including RFI-ungasketed joints) whose greatest dimension is greater than one-half wavelength of the highest source frequency of interest, or

(c) cable penetrations using unshielded cables or shielded cables which do not employ bulkhead connectors and circumferential low impedance bonding of the cable shield to the vehicle structure.)

7.4 Vehicle Triboelectric Charging

a. Purpose. The purpose of this requirement is to ensure that equipment will not deviate from its specified performance during or after exposure to the electromagnetic effects of triboelectric charging.

b. Applicability. This requirement applies to launch vehicles, equipment and fairings.

c. Requirement. This requirement shall be in accordance with the requirements of the Evolved Expendable Launch Vehicle Standard Interface Specification, paragraphs 3.2.6.1.5, 3.2.6.1.6 and 3.2.6.1.7.

d. Verification. Verification shall be by methods established or approved by the procuring activity.

(This requirement is a default requirement to be used until a new standard dedicated to ESD can be developed to comprehensively address ESD requirements for space and launch equipment during launch and on-orbit operations.)

(P) 7.5 Vehicle EMP

(This requirement will be included in a future version of this document. However, see MIL-STD-464A, paragraph 5.5, for guidance in developing requirements for a specific program.)

(P) 7.6 Vehicle Lightning

(This requirement will be included in a future version of this document. However, see MIL-STD-464A, paragraph 5.4, for guidance in developing requirements for a specific program.)

7.7 Vehicle Bonding

a. Purpose. The purpose of this requirement is to ensure that vehicle equipment electrical bonds are adequate to provide vehicle EMC and do not generate PIM.

b. Applicability. This requirement applies to all vehicles which will operate on a launch vehicle or in space.

c1. Requirement: Cable, connector, ground reference system and related bonds. All electrical wire, cable, cable shield, connector, ground reference system(s) and related bonds shall have a DC resistance no greater than 2.5 milliohms.

c2. Requirement: ESD mitigation bonds. All vehicle equipment shall be electrically referenced together by bonds such that the equivalent resistance of all bonds to a single piece of equipment shall not exceed $(10^9/A)$ ohms, where A is the surface area of the piece of equipment in square centimeters.

d. Verification. Verification shall be by test, using standard measurement methods, as appropriate and as approved by the procuring authority.

(Note: Bonding requirements specific to PIM mitigation are given in subrequirement 7.3c1(Vehicle PIM, Electrical bonds).

(P) 7.8 Vehicle Grounding

- a. Purpose.** The purpose of this requirement is to ensure that vehicle grounding is adequate to provide vehicle EMC.
- b. Applicability.** This requirement applies to all vehicles which will operate on a launch vehicle or in space.
- c. Requirement.** *(To be included in a future version of this document.)*

Appendix A. Requirements' Primary Heritage

The following table gives the primary sources of the corresponding requirements. Other sources may also have been used, including expert opinion of industry and Aerospace EMC personnel, but all sources are too numerous to list.

Req.	Requirement Title	Primary Heritage
4.	GENERAL REQUIREMENTS	
4.1	Units and Subsystems	MIL-STD-461F
4.2	Vehicle	MIL-STD-1541A
4.3	EMISMs	MIL-STD-1541A
4.4	Service Life	Aerospace best practice*
5.	DETAILED REQUIREMENTS, GROUND UNITS AND SUBSYSTEMS	
5.1	Ground Support Equipment	MIL-STD-461F
6.	DETAILED REQUIREMENTS, SPACE AND LAUNCH UNITS AND SUBSYSTEMS	
6.01	Conducted Emissions, Power and Command/Control Lines, 30Hz-50MHz (CE101/102A)	MIL-STD-461F, MIL-STD-1541A
6.03	Conducted Emissions, Common Mode to Structure, Frequency Domain, 30Hz-50MHz	NASA GEVS-SE REV A
6.06	Conducted Emissions, Ripple and Periodic Transients, Power and Command/Control Lines	MIL-STD-1541A, AIAA S-122-2007
6.07	Conducted Emissions, Short-Duration Aperiodic Transients, Power and Command/Control Lines (CE07)	MIL-STD-461C/462, MIL-STD-1541A, Aerospace TOR-2005(8583)-2
6.08	Conducted Emissions, Inrush and Outrush Currents, Power and Command/Control Lines	Aerospace best practice*
6.10	Conducted Susceptibility, Power and Command/Control Lines, 30Hz to 150kHz (CS101)	MIL-STD-461F, MIL-STD-1541A, AIAA S-122-2007
6.11	Conducted Susceptibility, Power and Command/Control Lines, 150kHz-50MHz (CS02)	MIL-STD-461C, MIL-STD-1541A, MIL-STD-462
6.12	Conducted Susceptibility, Short-Duration High-Level Aperiodic Transients, Power and Command/Control Lines (CS06)	MIL-STD-461C, MIL-STD-462, MIL-STD-1541A

Req.	Requirement Title	Primary Heritage
6.13	Conducted Susceptibility, Aperiodic Surges, Operate Through, Power and Command/Control Lines	MIL-STD-1541A, Aerospace TOR-2005(8583)-2
6.14	Conducted Susceptibility, Aperiodic Surges, Survival, Power and Command/Control Lines	MIL-STD-1541A, Aerospace TOR-2005(8583)-2
6.16	Conducted Susceptibility, Ground Plane Injection, 30Hz-150kHz	Aircraft requirement provided by Ken Javor, EMC Compliance and AIAA EMC Committee on Standards
6.17	Conducted Susceptibility, Ground Plane Injection, 150kHz-100MHz	Aircraft requirement provided by Ken Javor, EMC Compliance and AIAA EMC Committee on Standards
6.18	Conducted Susceptibility, Ground Plane Injection, Transient	Aircraft requirement provided by Ken Javor, EMC Compliance and AIAA EMC Committee on Standards
6.21	Conducted Susceptibility, Antenna Port, Intermodulation, 15kHz-40GHz (CS103)	MIL-STD-461F
6.22	Conducted Susceptibility, Antenna Port, Rejection of Undesired Signals, 30Hz-40GHz (CS104)	MIL-STD-461F
6.23	Conducted Susceptibility, Antenna Port, Cross Modulation, 30Hz-40GHz (CS105)	MIL-STD-461F
6.24	Radiated Emissions, Electric Field, 14kHz-18GHz (RE102)	MIL-STD-461F, Aerospace best practice*
6.25	Conducted Emissions, Antenna Terminal, 10kHz-100GHz (CE106)	MIL-STD-461F, MIL-STD-1541A, Aerospace best practice*
6.26	Radiated Emissions, (Transmitter) Antenna Spurious and Harmonic Outputs, 10kHz-100GHz (RE103)	MIL-STD-461F, MIL-STD-1541A, Aerospace best practice*
6.27	Radiated Susceptibility, Electric Field, 10kHz-40GHz (RS103)	MIL-STD-461F, NASA CR 4776, Aerospace TOR-2005 (1663)-3790, MIL-STD-1541A
6.28	Conducted Susceptibility, Antenna Port Direct Injection (RS103alt)	Requirement 6.27, Aerospace best practice*
6.30	Conducted Susceptibility, Bulk Cable Injection, 10kHz-200MHz (CS114)	MIL-STD-461F

Req.	Requirement Title	Primary Heritage
6.31	Conducted Susceptibility, Bulk Cable Injection, Impulse Excitation (CS115)	MIL-STD-461F
6.32	Conducted Susceptibility, Damped Sinusoidal Transients, Cables and Power Leads, 10kHz-100MHz (CS116)	MIL-STD-461F
6.33	Radiated Emissions, (AC) Magnetic Field, 30Hz-100kHz (RE101)	MIL-STD-461F
6.34	Radiated Emissions, DC Magnetic Field	MIL-STD-1541A, NASA SP-8018, NASA SP-8037
6.35	Radiated Emissions, DC Magnetic Dipole Moment	NASA SP-8018, NASA SP-8037
6.36	Radiated Susceptibility, (AC) Magnetic Field, 30Hz-100kHz (RS101)	MIL-STD-461F
6.37	Radiated Susceptibility, Magnetic and Electric (Induction) Fields, Spikes and Power Frequencies (RS02)	MIL-STD-461C, MIL-STD-462
6.40	Passive Intermodulation (PIM), General	Aerospace best practice*
6.41	Passive Intermodulation (PIM), Conducted RF Paths to RF Interfaces	Aerospace best practice*
6.42	Electrostatic Discharge (ESD), Surface Materials	NASA TP 2361, NASA/TP-2003-21228, NASA SP-8111
6.43	Electrostatic Discharge (ESD), Susceptibility	IEC 61000-4-2
6.45	EMP (RS105), Space and Launch Units and Subsystems	MIL-STD-461F
6.46	Multipaction	ECSS-E-20-01A
6.48	Lightning	RTCA/DO-160
6.51	Power Isolation and Grounding	MIL-STD-1541A, Aerospace best practice*
7.	DETAILED REQUIREMENTS, SPACE VEHICLES	
7.1	Vehicle EMC	Aerospace best practice*
7.3	Vehicle Passive Intermodulation (PIM)	Aerospace best practice*
7.4	Vehicle Triboelectric Charging	EELV SIS
7.7	Vehicle Bonding	MIL-B-5087B(ASG)

* Aerospace EMC departmental consensus of best practice, Electronics and Power Systems Department, Electromagnetic Effects Section.

SMC Standard Improvement Proposal

INSTRUCTIONS

1. Complete blocks 1 through 7. All blocks must be completed.
2. Send to the Preparing Activity specified in block 8.

NOTE: Do not be used to request copies of documents, or to request waivers, or clarification of requirements on current contracts. Comments submitted on this form do not constitute or imply authorization to waive any portion of the referenced document(s) or to amend contractual requirements. Comments submitted on this form do not constitute a commitment by the Preparing Activity to implement the suggestion; the Preparing Authority will coordinate a review of the comment and provide disposition to the comment submitter specified in Block 6.

**SMC STANDARD
CHANGE
RECOMMENDATION:**

1. Document Number

2. Document Date

3. Document Title

4. Nature of Change

(Identify paragraph number; include proposed revision language and supporting data. Attach extra sheets as needed.)

5. Reason for Recommendation

6. Submitter Information

a. Name

b. Organization

c. Address

d. Telephone

e. E-mail address

7. Date Submitted

8. Preparing Activity

Space and Missile Systems Center
AIR FORCE SPACE COMMAND
483 N. Aviation Blvd.
El Segundo, CA 91245
Attention: SMC/EAE