

REPORT DOCUMENTATION PAGE

Form Approved
OMB No. 0704-0188

Public reporting burden for this collection of information is estimated to average 1 hour per response, including the time for reviewing instructions, searching existing data sources, gathering and maintaining the data needed, and completing and reviewing this collection of information. Send comments regarding this burden estimate or any other aspect of this collection of information, including suggestions for reducing this burden to Department of Defense, Washington Headquarters Services, Directorate for Information Operations and Reports (0704-0188), 1215 Jefferson Davis Highway, Suite 1204, Arlington, VA 22202-4302. Respondents should be aware that notwithstanding any other provision of law, no person shall be subject to any penalty for failing to comply with a collection of information if it does not display a currently valid OMB control number. **PLEASE DO NOT RETURN YOUR FORM TO THE ABOVE ADDRESS.**

1. REPORT DATE (DD-MM-YYYY) 14-08-2015		2. REPORT TYPE Publication		3. DATES COVERED (From - To)	
4. TITLE AND SUBTITLE Coaxial Switch				5a. CONTRACT NUMBER	
				5b. GRANT NUMBER	
				5c. PROGRAM ELEMENT NUMBER	
6. AUTHOR(S) David J. Bamford et al				5d. PROJECT NUMBER	
				5e. TASK NUMBER	
				5f. WORK UNIT NUMBER	
7. PERFORMING ORGANIZATION NAME(S) AND ADDRESS(ES) Naval Undersea Warfare Center Division, Newport 1176 Howell Street, Bldg 102T, Code 00L Newport, RI 02841				8. PERFORMING ORGANIZATION REPORT NUMBER 102139	
9. SPONSORING / MONITORING AGENCY NAME(S) AND ADDRESS(ES) Naval Undersea Warfare Center Division, Newport 1176 Howell Street, Bldg 102T, Code 00L Newport, RI 02841				10. SPONSOR/MONITOR'S ACRONYM(S) NUWC	
				11. SPONSOR/MONITOR'S REPORT NUMBER(S) 102139	
12. DISTRIBUTION / AVAILABILITY STATEMENT Distribution A					
13. SUPPLEMENTARY NOTES					
14. ABSTRACT A coaxial switch having a housing and a shaft extending through and rotatably mounted to the housing. The shaft extends from opposite ends of the housing. Connector body members are attached to the housing and a support plate is mounted to the shaft. Conductor members are joined to the support plate. Each conductor member has a conductor and is configured to be inserted into a connector body member. The conductors of the conductor members are electrically connected together. When the coaxial switch is engaged, the conductor members are inserted into the connector body members. The coaxial switch becomes disengaged when a force is exerted on the shaft that causes the conductor members to be withdrawn from the connector body members. An axial force-producing mechanism produces a constant axial force on the shaft to maintain the coaxial switch in the engaged state.					
15. SUBJECT TERMS					
16. SECURITY CLASSIFICATION OF:			17. LIMITATION OF ABSTRACT SAR	18. NUMBER OF PAGES 27	19a. NAME OF RESPONSIBLE PERSON Annette M. Campbell
a. REPORT Unclassified	b. ABSTRACT Unclassified	c. THIS PAGE Unclassified			19b. TELEPHONE NUMBER (include area code) 401-832-4246



DEPARTMENT OF THE NAVY

OFFICE OF COUNSEL
NAVAL UNDERSEA WARFARE CENTER DIVISION
1176 HOWELL STREET NEWPORT RI 02841-1708

IN REPLY REFER TO

Attorney Docket No. 102139
14 August 15

The below identified patent application is available for licensing. Requests for information should be addressed to:

TECHNOLOGY PARTNERSHIP ENTERPRISE OFFICE
NAVAL UNDERSEA WARFARE CENTER
1176 HOWELL ST.
CODE 00T2, BLDG. 102T
NEWPORT, RI 02841

Serial Number 14/259,252
Filing Date 23 April 2014
Inventor David J. Bamford

Address any questions concerning this matter to the Office of Technology Transfer at (401) 832-1511.

DISTRIBUTION STATEMENT
Approved for Public Release
Distribution is unlimited

COAXIAL SWITCH

STATEMENT OF GOVERNMENT INTEREST

[0001] The invention described herein may be manufactured and used by or for the Government of the United States of America for governmental purposes without the payment of any royalties thereon or therefor.

CROSS REFERENCE TO OTHER PATENT APPLICATIONS

[0002] None.

BACKGROUND OF THE INVENTION

(1) Field of the Invention

The present invention generally relates to a rotary coaxial switch that when the switch is engaged; conductor members are inserted into connector body members in the switch. A force-producing mechanism produces a constant force on a central shaft to maintain the coaxial switch in an engaged conductive state. The switch becomes disengaged when a force stronger than the force producing mechanism is exerted on the shaft; thereby, causing the conductor members to be withdrawn from the connector body members.

(2) Description of the Prior Art

[0003] Coaxial switches are known in the art and are used in applications that require frequent transposition of two coaxial lines. For example, it may be necessary to switch an RF (radio frequency) receiver input between two different antennas. In such an application, two coaxial lines are connected to a RF coaxial switch; wherein, one coaxial line is connected to a first antenna and the other coaxial line is attached to a second antenna.

[0004] Some RF coaxial switches have a rotary-type configuration and utilize a shaft that can rotate to different positions in order to form an RF connection. One RF coaxial rotary switch is described in United States Patent No. 2,697,767, entitled "Coaxial Switch" and another RF coaxial rotary switch is described in United States Patent No. 2,432,476, entitled "Electrical Switch Device".

[0005] RF coaxial switches are typically used in environments that are prone to mechanical shocks and vibrations. For example, in military applications, the RF coaxial switches are mounted in racks that contain other equipment. As such, it is critical that a RF coaxial switch be able to withstand mechanical shocks and vibrations and to maintain an RF connection throughout a shock or a vibration event.

[0006] It has been found that shocks and vibrations on prior art rotary-type coaxial switches may cause the shaft in the coaxial switch to be displaced axially; thereby, breaking the RF connection. The displacement of the shaft causes the switch to reposition to a neutral position. The prior art RF coaxial rotary-type switches do not have any device or configuration to restore the RF connection without user intervention.

[0007] What is therefore needed is a coaxial switch that minimizes axial displacement of the switch shaft during a shock event so as to maintain connectivity.

SUMMARY OF THE INVENTION

[0008] The present invention is directed to a coaxial switch, with a housing having an inner wall surrounding an interior. A plurality of connector openings are in communication with the interior. The coaxial switch also comprises a plurality of coaxial connector body members mounted to the housing wherein each body member is mounted over a corresponding connector opening.

[0009] A shaft extends through and is rotatably mounted to the housing. The shaft has one section within the interior of the housing and another section extending from the opening in the housing at a first location. A further section extends from the opening in the housing at a second location.

[0010] The coaxial switch further comprises a support plate mounted to the section of the shaft that is within the interior of the housing. Conductor members are joined to the support plate wherein each conductor member has a conductor. Each conductor member is configured to be inserted into any of the coaxial connector body members.

[0011] The coaxial switch also comprises an axial force producing mechanism mounted to the section of the shaft extending from the housing at the first location. The mechanism produces a constant axial force on the shaft that urges the support plate against the inner wall so that the support plate impacts the connector openings in the housing.

[0012] The coaxial switch also includes a radial force producing member mounted on the shaft and adjacent to an intermediate section of the shaft. The intermediate section and the radial force producing member are drawn into a passageway of the housing when an axial force opposite to and greater than the force produced by the axial force producing mechanism is exerted on the shaft. The radial force producing member exerts a radial force on the shaft when the intermediate section forcibly contacts the radial force producing member within the passageway.

[0013] A knob is attached to the section of the shaft extending from the housing at the second location. The knob

enables a user to pull the shaft in a direction that is opposite to the axial force produced by the axial force producing mechanism.

[0014] The knob can also rotate the shaft to a different position. Releasing the knob enables the axial force produced by the axial force-producing member to pull the support plate against the inner wall of the housing so that a pair of conductor members are inserted into the appropriate coaxial connector body members and the conductors of the conductor members contact the conductors of coaxial cables that are connected to the coaxial connector body members.

BRIEF DESCRIPTION OF THE DRAWINGS

[0015] A more complete understanding of the invention and many of the attendant advantages thereto will be appreciated as the same becomes better understood by reference to the following detailed description when considered in conjunction with the accompanying drawings wherein corresponding reference characters indicate corresponding parts throughout the several views of the drawings and wherein:

[0016] **FIG. 1** is a perspective view of a prior art coaxial switch;

[0017] **FIG. 2** is a side view, in cross-section, of the prior art coaxial switch of **FIG. 1**;

[0018] **FIG. 3** is a front, perspective view of the coaxial switch of the present invention;

[0019] **FIG. 4** is a rear, perspective view of the coaxial switch of **FIG. 3**;

[0020] **FIG. 5** is a front view of the coaxial switch of **FIG. 3**;

[0021] **FIG. 6** is right side view of the coaxial switch of **FIG. 3** with the view showing an intermediate section of the shaft and a radial force producing member in phantom;

[0022] **FIG. 7** is a left side view of the coaxial switch of **FIG. 3** with the view also showing the intermediate section of the shaft within the interior of the housing;

[0023] **FIG. 8** is a rear view of the coaxial switch of **FIG. 3**;

[0024] **FIG. 9** is a cross-sectional view taken along reference line 9-9 in **FIG. 8**;

[0025] **FIG. 10** is top view of a support plate that is attached to the shaft of the coaxial switch and located within the interior of the housing with the view taken along reference line 10-10 in **FIG. 9**; and

[0026] **FIG. 11** is a cross-sectional view taken along reference line 11-11 in **FIG. 10**.

DETAILED DESCRIPTION OF THE INVENTION

[0027] Referring to **FIGS. 1** and **2**; there is shown a prior art coaxial rotary switch **10**. The switch **10** comprises a housing **12**, a shaft **14** and a knob **16** which is attached to the shaft. The housing **12** has an interior **18**, a first end **20** and opposite, a second end **22**. A connector plate (not shown) having coaxial connectors is attached to the shaft **14**. Coaxial connector body members **23** are mounted to the first end **20**. The shaft **14** extends through a central opening in the first end **20** and through a central opening in the second end **22**.

[0028] The shaft **14** includes a section **24** that is located within the interior **18**. The section **24** has a diameter that is greater than the diameter of the remaining portion of the shaft **14**. The section **24** includes a beveled or angled portion **26**. The housing **12** also includes an annular structure **27** that defines a passageway **28** that leads to the central opening in the second end **22**. A garter spring **30** is mounted to the shaft **14** and is adjacent to the beveled portion **26**.

[0029] In order to disengage the switch **10**; the user pulls the knob **16** in the direction of arrow **32** for a distance "X". The distance "X" is the distance that the shaft **14** can axially move for the annular structure **27** to contact the second end **22**. Such movement of the shaft **14** causes the intermediate section **24** and the garter spring **30** to be pulled or drawn into the

passageway **28** wherein the garter spring exerts a radial force on the shaft thereby creating resistance.

[0030] In order to engage the switch **10**; the user rotates the shaft **14** (as indicated by direction **33**) to a different position and then releases the knob **16** so that the knob moves in the direction indicated by arrow **34**. The shaft **14** can rotate in clockwise and counter-clockwise directions (see **FIG. 1**). The garter spring **30** does not provide sufficient resistance to prevent the switch **10** from disengaging and breaking connectivity when a mechanical shock event occurs.

[0031] Referring to **FIGS. 3-9**, there is shown a coaxial switch **100** of the present invention. The coaxial switch **100** is a rotary-type coaxial switch and has a useful frequency range of DC to 10 GHz. The switch **100** comprises a housing **102** with an interior **104** and an inner wall **105**. The housing **102** comprises a first end **106** and a second end **108**. The first end **106** has a central opening **109** and a plurality of connector openings **110** arranged about the central opening. The second end **108** includes a central opening **112** that is aligned with the central opening **109**. A plurality of coaxial connector body members **114** are mounted to the first end **106**.

[0032] Each coaxial connector body member **114** is configured to be connected to a coaxial cable (not shown) and is mounted over a corresponding connector opening **110**. Each coaxial

connector body member **114** has an interior **116** which can be accessed through the interior **104** of the housing **102**. A front plate **118** is attached to the second end **108** via screws or suitable fasteners **119**.

[0033] The coaxial switch **100** further comprises a shaft **120** which extends through and is rotatably mounted to the housing **102**. The shaft **120** has a first section **122** that extends through the central opening **109**. The shaft **120** further comprises a second section **124** that extends through the interior **104** and a third section **126** which extends from the central opening **112**.

[0034] The first section **122** has a diameter and extends to a distal end **128**. The second section **124** comprises an intermediate section **130** with a generally cylindrical portion **132** and a beveled or angled portion **134**. The cylindrical portion **132** has a diameter that is greater than the diameter of portion **124A** of the shaft section **124**. The difference in diameters between the cylindrical portion **132** and the portion **124A** allows for the formation of the beveled or angled portion **134**. The purpose of the intermediate section **130** is discussed in detail in the following description.

[0035] Referring to **FIGS. 10** and **11**, the coaxial switch **100** further comprises a support plate **140** which is attached to the section **124** of the shaft **120**. The support plate **140** comprises a pair of spaced apart conductor members **142** and **144**. The

conductor members **142** and **144** have conductors **146** and **147**, respectively. A conductive member **148** is disposed within a shield **149** and is conductively joined to the conductors **146** and **147** to form a signal path. Each conductor member **142** and **144** is configured to be inserted into the interior **116** of any coaxial connector body member **114**.

[0036] The shaft **120** is capable of axial movement. Since the support plate **140** is attached to the shaft **120**; the support plate will also be axially displaced when the shaft is axially displaced. When the direction of the axial movement of the shaft **120** is towards the first end **106** of the housing **102** and the conductor members **142** and **144** are aligned with the desired coaxial connector body members **114**; the conductor members are inserted through the appropriate connector openings **110** and into the interiors **116** of the desired coaxial connector body.

[0037] In a preferred embodiment, the conductor members **142** and **144** are female-type coaxial connector conductors. In one embodiment, each of these female-type connector conductors is a female N-type connector. However, it is to be understood that other types of coaxial connector configurations are possible and that the invention is not limited to female N-type connectors.

[0038] Referring again to **FIG. 9**, the housing **102** includes an annular structure **150** that is joined to or formed on the inner wall **105**. The annular structure **150** defines a bore or

passageway **152** that leads to the central opening **112** in the second end **108**. A radial force producing member **154** is mounted on the section **124** of the shaft **120** adjacent to the beveled portion **134**. The radial force producing member **154** is located between the intermediate section **130** and the annular structure **150**. In a preferred embodiment, the radial force producing member **154** is a garter spring, specifically an extension garter spring which exerts inward radial force resisting expansion.

[0039] When an axial force is exerted on the shaft **120** as indicated by arrow **160** (see **FIG. 9**), the intermediate section **130** moves toward the annular structure **150** such that the beveled portion **134** and the radial force producing member **154** move into the passageway **152** wherein the intermediate section forcibly contacts the radial force producing member to exert a radial force on the shaft **120**; thereby, creating resistance.

[0040] The coaxial switch **100** further comprises an axial force producing mechanism **170** on the first section **122** of the shaft **120**. The axial force producing mechanism **170** comprises a retainer device **172** that is attached to the distal end **128**.

[0041] In one embodiment, the retainer device **172** is attached to the distal end **128** via a screw or fastener **176**. In such an embodiment, the screw **176** is threadedly engaged with a threaded bore formed in the first section **122**. In one embodiment, the retainer device **172** is substantially flat. In a preferred

embodiment, the retainer device **172** is substantially circular in shape. In another embodiment, the retainer device **172** is a metal washer.

[0042] The axial force producing mechanism **170** further comprises a spring member **180** that is interposed between the retainer device **172** and the first end **106** of the housing **102**. The spring member **180** produces a constant and pushing axial force onto the retainer device **172** which then pulls the shaft **120** and the support plate **140** toward the first end **106** of the housing **102**. This constant axial force is indicated by arrow **182** in **FIG. 9**.

[0043] In an alternate embodiment, the retainer device **172** and the fastener **176** are not used and the distal end portion **128** is formed with a diameter that is greater than the diameter of the first section **122**. In such an embodiment, the spring member **180** is interposed between the enlarged distal end portion **128** and the first end **106** of the housing **102**.

[0044] The coaxial switch **100** further comprises a knob or handle **200** that is attached to the third section **126** of the shaft **120**. The knob **200** enables a user to pull the shaft **120** in a direction indicated by arrow **160** that is opposite the axial force produced by the axial force producing mechanism **170** and to rotate the shaft **120** to different positions.

[0045] A user may form a signal path between coaxial cables that are connected to corresponding coaxial connector body members **114** on the first end **106** of the housing **102**. The user accomplishes this by using the knob **200** to pull the shaft **120** in a direction indicated by the arrow **160** with a force sufficient to overcome the axial force produced by axial force producing member **170** and the radial force produced by radial force producing member **154**. The user pulls the knob **200** outward for a distance "Z" shown in **FIG. 7** in order to disengage the coaxial switch **100**.

[0046] Once the user pulls the knob **200** outwardly with the requisite force; the user then rotates the shaft **120** so that the conductor members **142** and **144** on the support plate **140** are aligned with the appropriate pair of connector body members **114**. Alignment is achieved by a stop in motion in that the support plate **140** limits the amount of rotation. The connectors can only move ninety degrees such that the plate **140** will stop and the user can release the knob **200**. The user then releases the knob **200** so that the axial force produced by axial force producing mechanism **170** pulls or draws the conductor members **142** and **144** into the appropriate coaxial connector body members **114** so that the conductors **146** and **147** conductively contact the conductors in the coaxial cables that are attached to the coaxial connector body members.

[0047] In order to create a signal path between another pair of coaxial cables that are attached to the coaxial connector body members **114**; the user pulls the knob **200** for a distance "Z" in the direction indicated by arrow **160** and then rotates the shaft **120** so that the conductor members **142** and **144** are aligned with a different combination of coaxial connector body members. The user then releases the knob **200** so that the axial force produced by axial force producing mechanism **170** pulls or draws the conductor members **142** and **144** into the interiors **116** of the different combination of coaxial connector body members **114**. This action forms a signal path between the coaxial cables connected to these desired coaxial connector body members **114**.

[0048] It will be understood that many additional changes in the details, materials, steps and arrangement of parts, which have been herein described and illustrated in order to explain the nature of the invention, may be made by those skilled in the art within the principle and scope of the invention as expressed in the appended claims.

[0049] The foregoing description of the preferred embodiments of the invention has been presented for purposes of illustration and description only. It is not intended to be exhaustive nor to limit the invention to the precise form disclosed; and obviously many modifications and variations are possible in light of the above teaching. Such modifications and variations

Attorney Docket No. 102139

that may be apparent to a person skilled in the art are intended to be included within the scope of this invention as defined by the accompanying claims.

COAXIAL SWITCH

ABSTRACT OF THE DISCLOSURE

A coaxial switch having a housing and a shaft extending through and rotatably mounted to the housing. The shaft extends from opposite ends of the housing. Connector body members are attached to the housing and a support plate is mounted to the shaft. Conductor members are joined to the support plate. Each conductor member has a conductor and is configured to be inserted into a connector body member. The conductors of the conductor members are electrically connected together. When the coaxial switch is engaged, the conductor members are inserted into the connector body members. The coaxial switch becomes disengaged when a force is exerted on the shaft that causes the conductor members to be withdrawn from the connector body members. An axial force-producing mechanism produces a constant axial force on the shaft to maintain the coaxial switch in the engaged state.

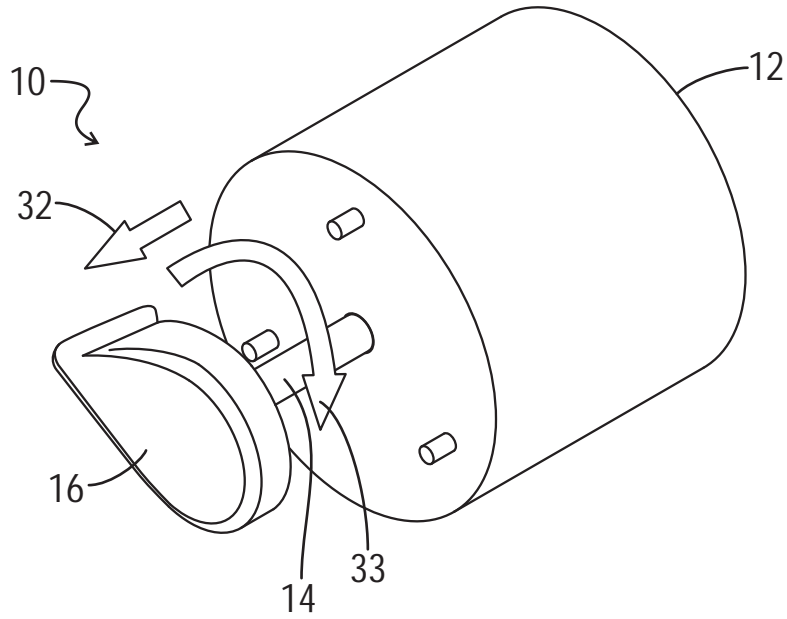

**FIG. 1
(PRIOR ART)**

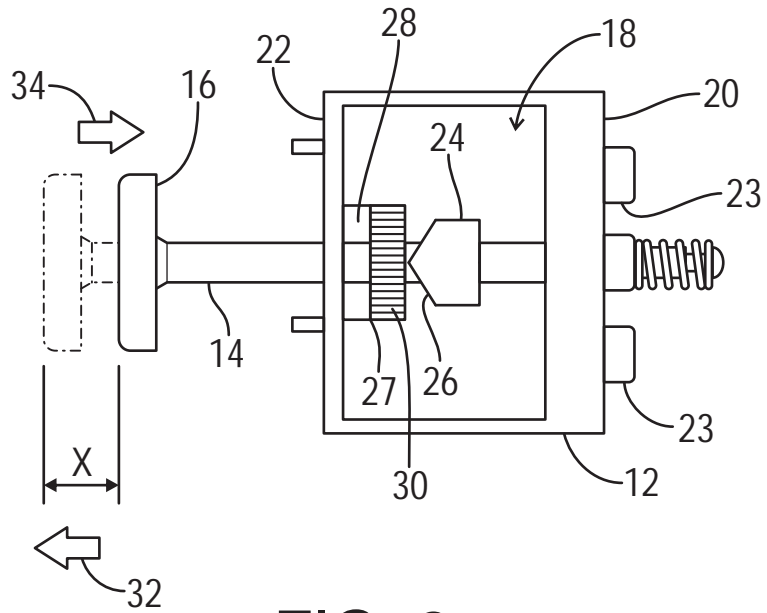

**FIG. 2
(PRIOR ART)**

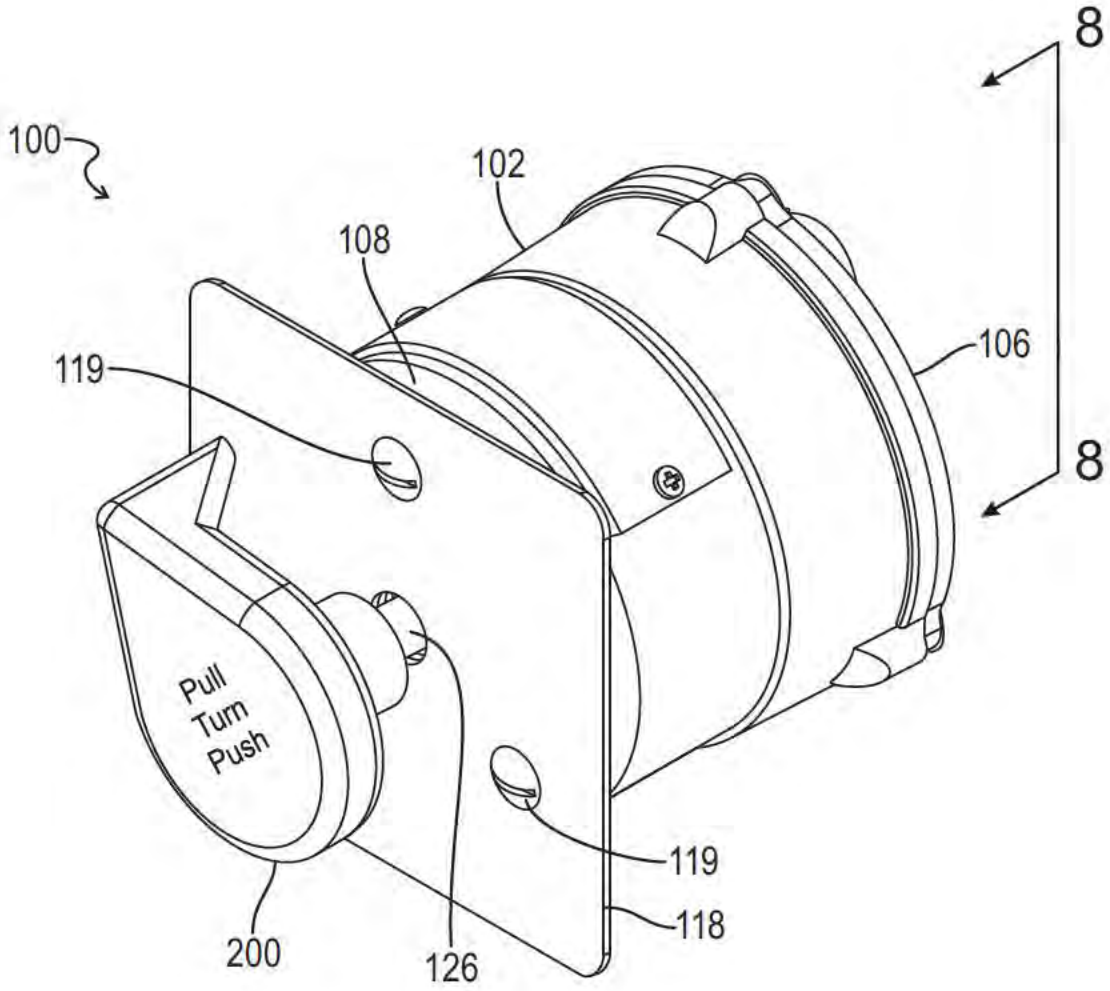

FIG. 3

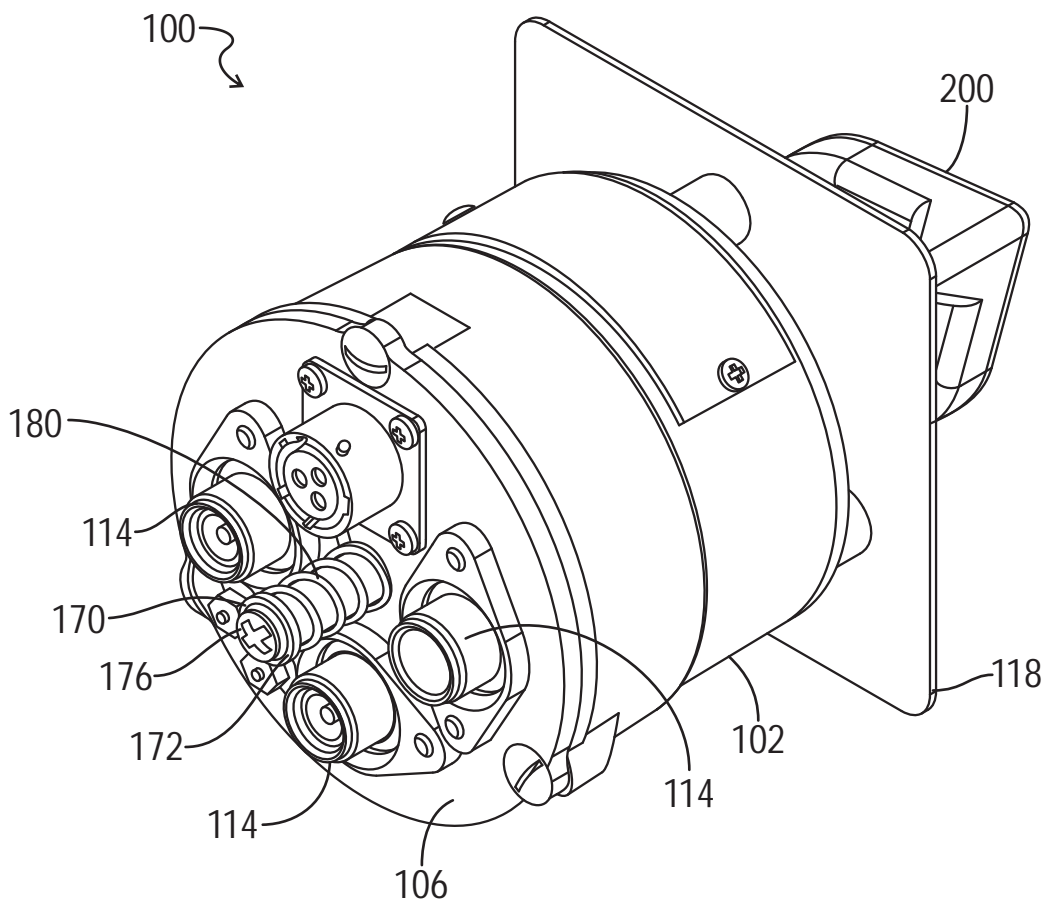

FIG. 4

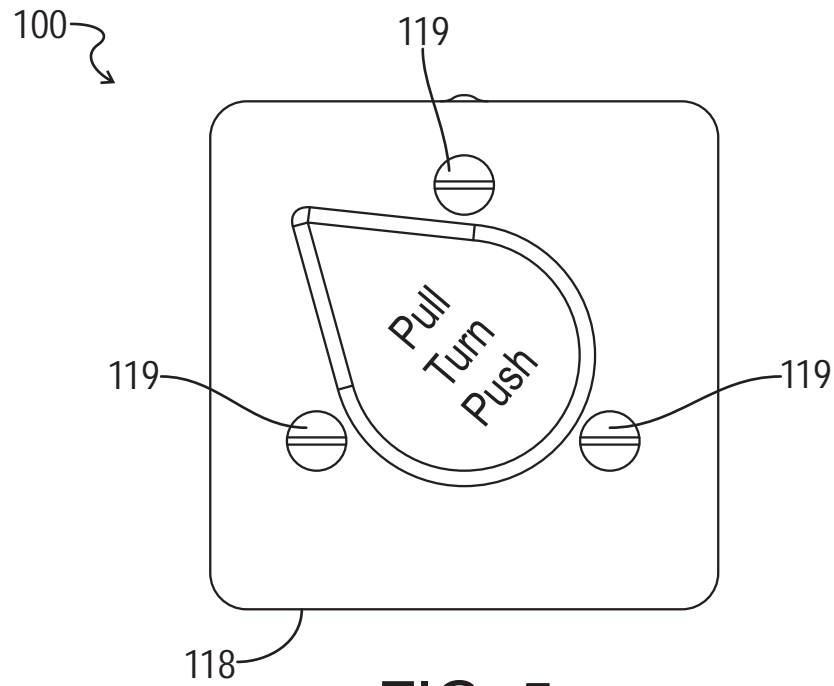

FIG. 5

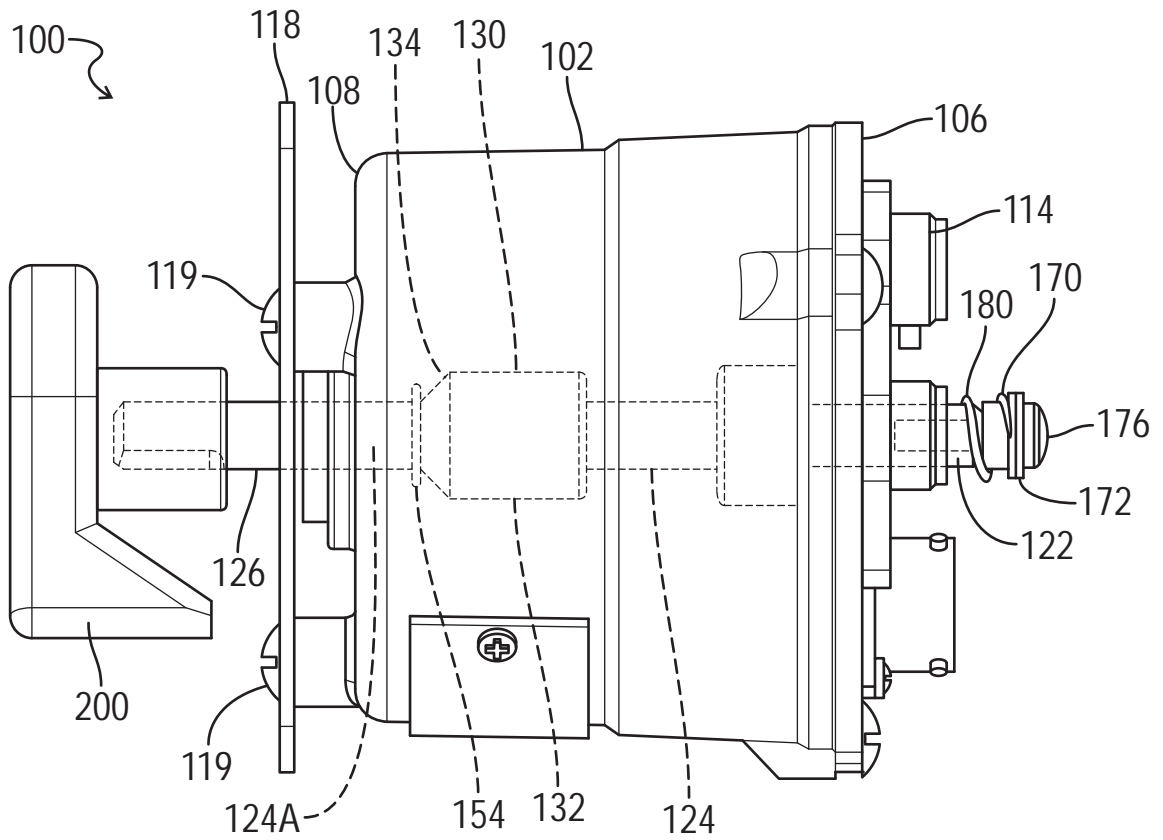

FIG. 6

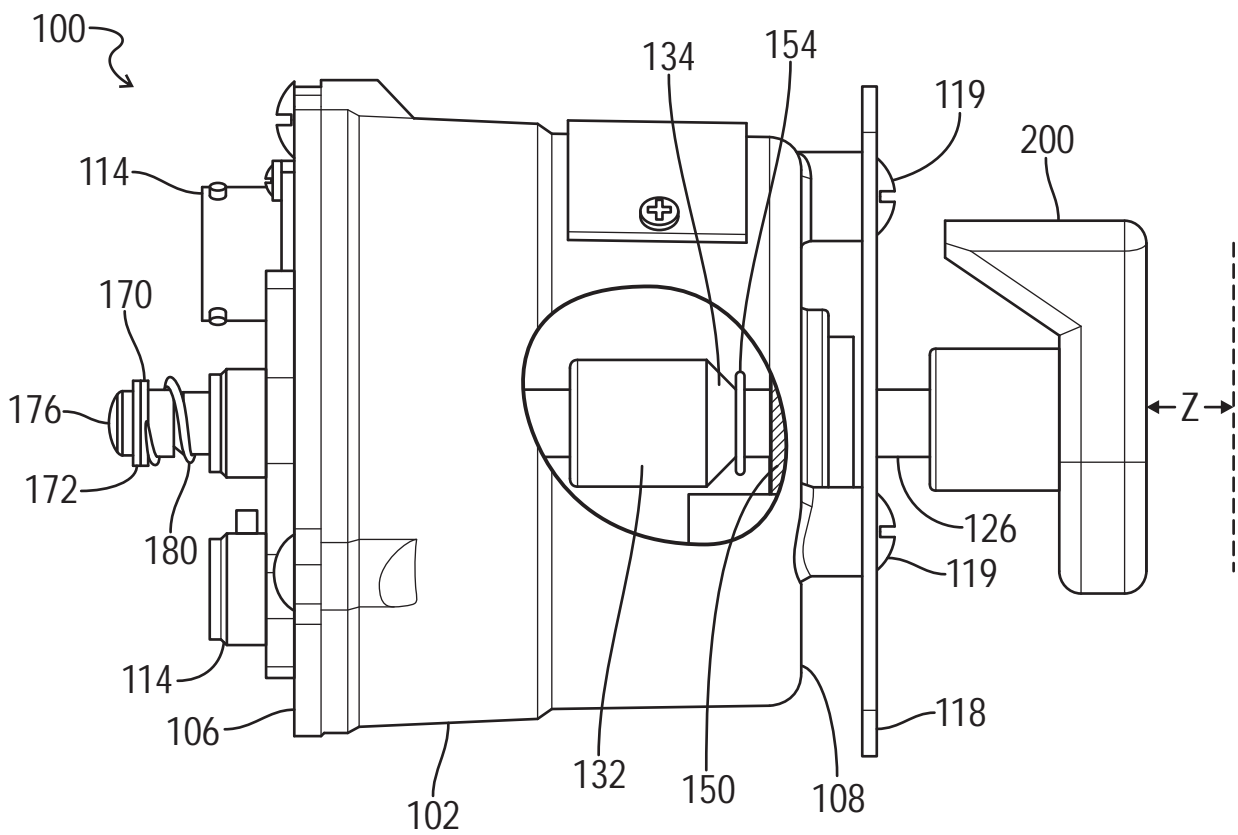

FIG. 7

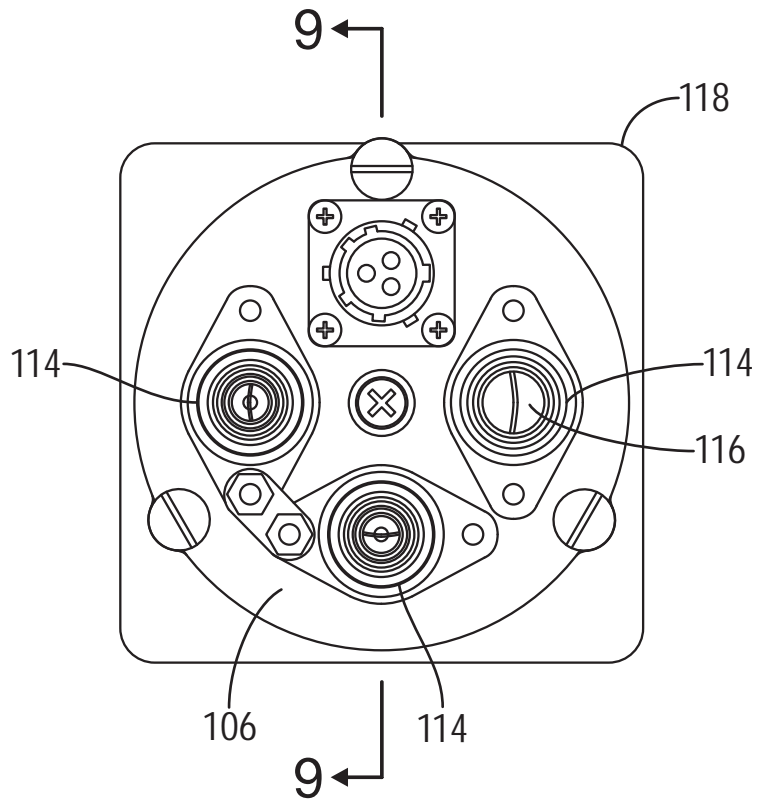

FIG. 8

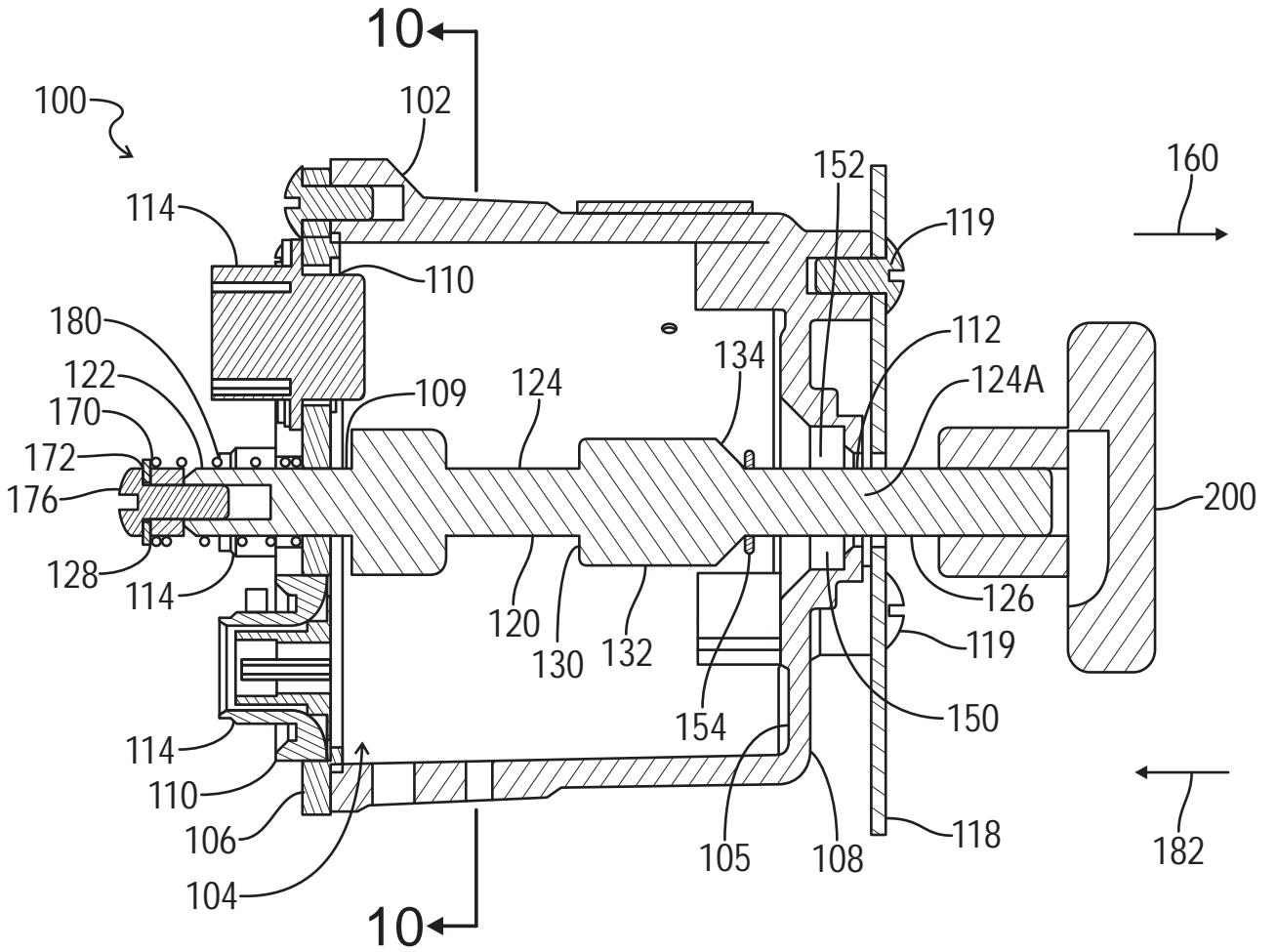

FIG. 9

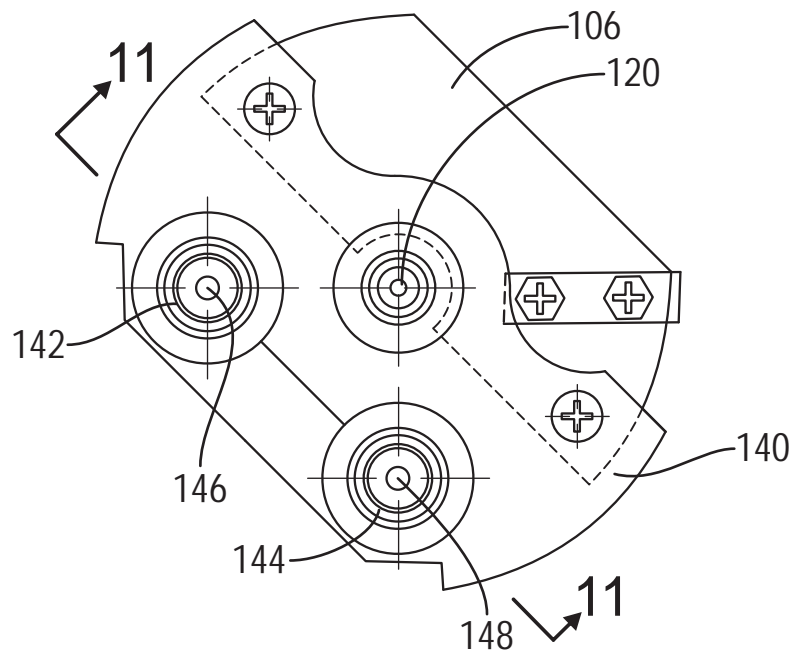

FIG. 10

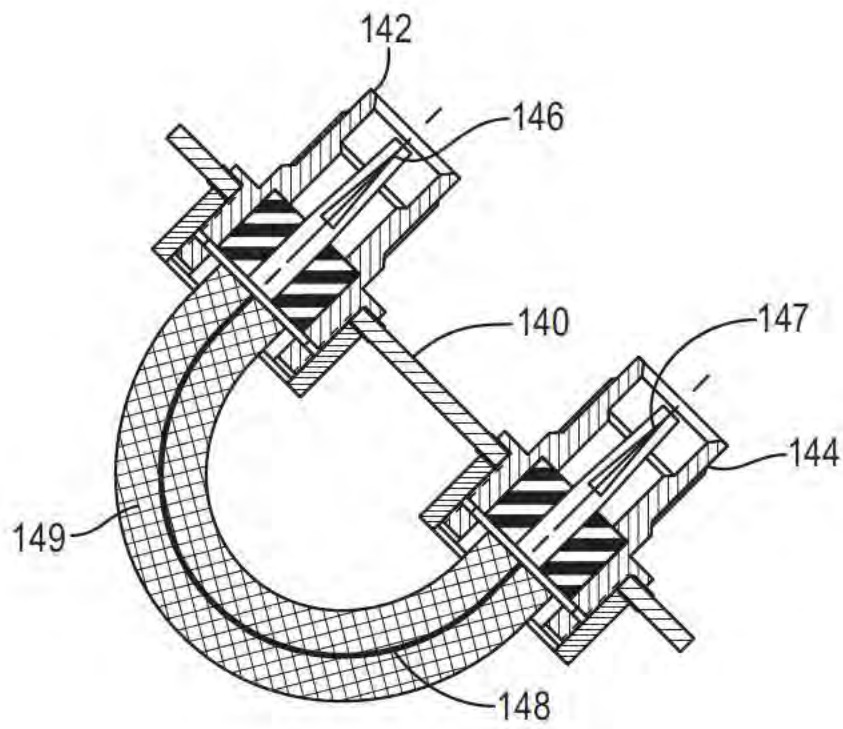

FIG. 11