

# REPORT DOCUMENTATION PAGE

Form Approved  
OMB No. 0704-0188

Public reporting burden for this collection of information is estimated to average 1 hour per response, including the time for reviewing instructions, searching existing data sources, gathering and maintaining the data needed, and completing and reviewing this collection of information. Send comments regarding this burden estimate or any other aspect of this collection of information, including suggestions for reducing this burden to Department of Defense, Washington Headquarters Services, Directorate for Information Operations and Reports (0704-0188), 1215 Jefferson Davis Highway, Suite 1204, Arlington, VA 22202-4302. Respondents should be aware that notwithstanding any other provision of law, no person shall be subject to any penalty for failing to comply with a collection of information if it does not display a currently valid OMB control number. **PLEASE DO NOT RETURN YOUR FORM TO THE ABOVE ADDRESS.**

<b>1. REPORT DATE (DD-MM-YYYY)</b> 06-08-2015		<b>2. REPORT TYPE</b> Publication		<b>3. DATES COVERED (From - To)</b>	
<b>4. TITLE AND SUBTITLE</b> Twin-Axial Wire Antenna				<b>5a. CONTRACT NUMBER</b>	
				<b>5b. GRANT NUMBER</b>	
				<b>5c. PROGRAM ELEMENT NUMBER</b>	
<b>6. AUTHOR(S)</b> David A. Tonn				<b>5d. PROJECT NUMBER</b>	
				<b>5e. TASK NUMBER</b>	
				<b>5f. WORK UNIT NUMBER</b>	
<b>7. PERFORMING ORGANIZATION NAME(S) AND ADDRESS(ES)</b> Naval Under Warfare Center Division, Newport 1176 Howell St., Code 00L, Bldg 102T Newport, RI 02841				<b>8. PERFORMING ORGANIZATION REPORT NUMBER</b> 300030	
<b>9. SPONSORING / MONITORING AGENCY NAME(S) AND ADDRESS(ES)</b> Naval Under Warfare Center Division, Newport 1176 Howell St., Code 00L, Bldg 102T Newport, RI 02841				<b>10. SPONSOR/MONITOR'S ACRONYM(S)</b> NUWC	
				<b>11. SPONSOR/MONITOR'S REPORT NUMBER(S)</b> 300030	
<b>12. DISTRIBUTION / AVAILABILITY STATEMENT</b>  Distribution A					
<b>13. SUPPLEMENTARY NOTES</b>					
<b>14. ABSTRACT</b>  An antenna includes a polymer coating having a VLF/LF element and an HF/VHF element embedded therein. A blocking choke is interposed between the VLF/LF element and the antenna feed to block HF/VHF signals. Small chokes are regularly positioned on the VLF/LF element to eliminate resonances caused by mutual capacitance between the elements. Reactive loads are positioned in said HF/VHF element at regular intervals for optimizing performance of the antenna in the HF/VHF radio bands. In further embodiments the antenna is provided as a floating antenna with the elements helically arranged therein.					
<b>15. SUBJECT TERMS</b>					
<b>16. SECURITY CLASSIFICATION OF:</b>			<b>17. LIMITATION OF ABSTRACT</b>  SAR	<b>18. NUMBER OF PAGES</b>  15	<b>19a. NAME OF RESPONSIBLE PERSON</b> Annette M. Campbell
<b>a. REPORT</b> Unclassified	<b>b. ABSTRACT</b> Unclassified	<b>c. THIS PAGE</b> Unclassified			<b>19b. TELEPHONE NUMBER (include area code)</b> 401-832-4246



**DEPARTMENT OF THE NAVY**

OFFICE OF COUNSEL  
NAVAL UNDERSEA WARFARE CENTER DIVISION  
1176 HOWELL STREET NEWPORT RI 02841-1708

IN REPLY REFER TO

Attorney Docket No. 300030  
6 August 15

The below identified patent application is available for licensing. Requests for information should be addressed to:

TECHNOLOGY PARTNERSHIP ENTERPRISE OFFICE  
NAVAL UNDERSEA WARFARE CENTER  
1176 HOWELL ST.  
CODE 00T2, BLDG. 102T  
NEWPORT, RI 02841

Serial Number 14/280,889  
Filing Date 19 May 2014  
Inventor David A. Tonn

Address any questions concerning this matter to the Office of Technology Transfer at (401) 832-1511.

DISTRIBUTION STATEMENT  
Approved for Public Release  
Distribution is unlimited

**TWIN-AXIAL WIRE ANTENNA**

**STATEMENT OF GOVERNMENT INTEREST**

[0001] The invention described herein may be manufactured and used by or for the Government of the United States of America for governmental purposes without the payment of any royalties thereon or therefor.

**CROSS REFERENCE TO OTHER PATENT APPLICATIONS**

[0002] None.

**BACKGROUND OF THE INVENTION**

**(1) Field of the Invention**

[0003] The present invention is directed to a linear antenna for dual frequencies and a method for designing such an antenna and more particularly to a twin-axial floating antenna that can be deployed from a vessel.

**(2) Description of the Prior Art**

[0004] Previous work on buoyant cable antenna (BCA) improvements have led to antennas that have improved performance in the HF band (e.g., U.S. Patent No. 7,868,833 entitled "Ultra wideband buoyant cable antenna element") but this improvement came at the expense of the performance of the antenna in the VLF/LF band (10 kHz- 200kHz. This occurred because the methods involved required the use of series capacitive loading along the

length of the antenna wire. This creates a high pass filter in the antenna and prevents current flow in the VLF/LF bands.

**[0005]** U.S. Patent 8,203,495, entitled "Modular VLF/LF and HF buoyant cable antenna and method" introduces a useful method of including the VLF/LF capability back into the antenna. In this patent, the VLF/LF signals are received on the braid of a piece of coaxial cable that is connected in series with the loaded HF antenna. However, this method suffers from two major shortfalls. The first is that the attenuation of the coaxial cable hinders the gain of the HF antenna, since HF signals must pass through the coaxial cable to reach the overall antenna feed point. The second is that the overall antenna length increases to over 150 feet long, which is undesirable from a mechanical point of view since it affects the speed-depth curves and hinders the submarine's operations when using the antenna.

#### **SUMMARY OF THE INVENTION**

**[0006]** It is a first object of the present invention to provide an antenna capable of operating in both HF/VHF and VLF/LF bands;

**[0007]** Another object is to provide such an antenna having good performance in the HF band while not sacrificing performance in the VLF band; and

[0008] Yet another object is to provide an antenna having a shorter length than known with series arrangements.

[0009] Accordingly, there is provided an antenna that includes a polymer coating having a VLF/LF element and an HF/VHF element embedded therein. A blocking choke is interposed between the VLF/LF element and the antenna feed to block HF/VHF signals. Small chokes are regularly positioned on the VLF/LF element to suppress resonances in the HF/VHF bands caused by mutual capacitance between the elements. Reactive loads are positioned in said HF/VHF element at regular intervals for optimizing performance of the antenna in the HF/VHF radio bands. In further embodiments the antenna is provided as a floating antenna with the elements helically arranged therein.

#### **BRIEF DESCRIPTION OF THE DRAWINGS**

[0010] Reference is made to the accompanying drawings in which are shown an illustrative embodiment of the invention, wherein corresponding reference characters indicate corresponding parts, and wherein:

[0011] FIG. 1 is a cross-sectional view of an antenna;

[0012] FIG. 2 is a diagram of a typical antenna;

[0013] FIG. 3 is a view of a section of an antenna; and

[0014] FIG. 4 is graph showing normalized performance gains of the current antenna over a prior art antenna.

**DETAILED DESCRIPTION OF THE INVENTION**

[0015] This invention combines the functionality of the two legacy buoyant cable antenna elements into a single antenna element while also providing for improved gain in the high frequency (HF, between 3MHz and 30MHz) and very high frequency (VHF, between 30MHz and 300kHz) radio bands to support improved communications for submerged submarines.

[0016] An embodiment shown in FIG. 1 and 2 overcomes limitations found in the prior art by utilizing a twin-axial geometry. As shown in FIG. 1, this antenna 10 employs two center conductors, a VLF conductor 12 and an HF conductor 14, instead of one in the prior art. The antenna 10 has a cylindrical geometry with a circular cross section of constant diameter  $d$  maintained over the length,  $l$ , of the antenna. Conductors 12 and 14 are embedded in a body 16 made from any polymer foam. The polymer foam should be positively buoyant in seawater, electrically insulating, chemical resistant and durable in normal seawater temperatures. Many different polymer foams are suitable for this purpose.

[0017] Antenna conductors 12 and 14 are embedded into body 16 and arranged so that their centroid is coincident with the axis 18 of the antenna over its entire length. The conductors 12 and 14 are, therefore, positioned on either side of the center 18 of antenna body 16, as shown in FIG. 1. The conductors 12 and 14

can be arranged parallel to one another or can be positioned helically at a constant pitch angle. In either embodiment, the spacing between the conductors,  $b$ , is constant along the entire length of the antenna 10. In one embodiment, the HF conductor 12 and the VLF conductor 14 each have the same gauge and are made from stranded conductors. In alternate embodiments, the two conductors 12 and 14 can be of differing gauges and can be either stranded or solid. In a prototype, both conductors were made from #22 solid copper wire arranged parallel to each other within a body 16.

**[0018]** Each of the conductors 12 and 14 carries signals from a separate portion of the radio spectrum. An antenna feed 20 is located at the proximate end of each conductor and is electrically joined to radio equipment (not shown). The VLF conductor 12 carries VLF/LF signals. At its distal end, VLF conductor 12 connects to environmental ocean water by means of a grounding ring 22. Grounding ring 22 is a short-circuit termination electrically connected to environmental water which is assumed to be at ground potential. The HF conductor 14 carries signals in the HF/VHF band and terminates at its distal end in an open circuit termination 24 prior to the end of the antenna 10. In another embodiment, open circuit termination 24 can terminate at the end of the antenna 10. Open circuit

termination 24 cannot electrically connect to grounding ring 22. This is necessary for maximum gain in the HF band.

**[0019]** To provide optimal HF/VHF performance, the HF conductor 14 is provided with a reactive load 26 at regular intervals along its length,  $dz_1$ . Reactive load 26 can be made from a single capacitor, a single capacitor and a single inductor connected in parallel, or a combination of these types of reactive loads. Reactive loads 26 are inserted in series with the HF conductor 14. In some embodiments, parallel capacitor inductor reactive loads can be used for one portion of the HF conductor 14, while the remainder of the HF conductor 14 uses capacitors alone. The capacitor and inductor are selected so as to optimize the performance of the antenna in the HF and VHF bands. In the prototype, single capacitors having a capacitance of 680 pF were used, with the distance between reactive loads,  $dz_1$ , being 1 meter apart.

**[0020]** The VLF conductor 12 connects to the HF conductor 14 at antenna feed 20 through a blocking choke 28. Blocking choke 28 is preferably a ferrite core shielded inductor chosen to keep applied signals in the HF and VHF bands from passing into the VLF/LF conductor 12.

**[0021]** Due to the mutual capacitance between the VLF conductor 12 and HF conductor 14, HF and VHF signals can couple from the HF conductor 14 onto the VLF conductor 12 and cause VLF



conductor 12 to resonate. The resonance of the VLF conductor 12 can affect the gain and impedance of the HF conductor 14 detrimentally. This resonance is suppressed by electrically interrupting the VLF conductor 12 at regular intervals by providing small chokes 30 at locations in conductor 12. Small choke 30 is chosen so that its impedance is high enough to stop the flow of current on the VLF conductor 12 but not so high as to impede the flow of current in the VLF/LF bands. The spacing between adjacent small chokes 30,  $dz_2$ , was chosen to be smaller than one-half of the shortest wavelength in the band or bands of operation of the HF conductor 14. In this way, the segments of the VLF conductor 12 interconnecting chokes 30 are sub-resonant. In the prototype, blocking choke 28 had a value of 22  $\mu\text{H}$ , and small chokes 30 all had a value of 1  $\mu\text{H}$ .

**[0022]** FIG. 3 shows a preferred embodiment of the invention, where the two wires are arranged as a twisted pair of constant pitch angle. FIG. 3, with the reactive loads 26 placed periodically along the HF/VHF wire 14 and the small chokes 30 placed repeatedly along the VLF/LF wire 12, with the entire assembly centered within a polymer foam jacket 16. Polymer foam jacket 16 is provided with hidden lines to show VLF/LF wire 12 and HF/VHF wire 14 within. While reactive loads 26 and chokes 36 should be positioned periodically on wire 14 and wire 12, the

placement period is not required to be the same for each wire 14 and 12.

**[0023]** FIG. 4 shows the measured normalized HF gain performance of the first working model compared with the gain of a legacy BCA element. HF gain performance line 40 shows the gain of the first working model, and HF gain performance line 42 shows the gain of the legacy element. Improved gain performance of up to 5 dB is noted in the region from 8-17 MHz. VLF performance was measured at 24 kHz using the station at Cutler, ME as a beacon. The measurement showed performance comparable to a legacy BCA. (Note that due to the nature of VLF propagation, measurements across the band are not possible and so performance is measured using signals from fixed stations.)

**[0024]** It will be understood that many additional changes in the details, materials, steps and arrangement of parts, which have been herein described and illustrated in order to explain the nature of the invention, may be made by those skilled in the art within the principle and scope of the invention as expressed in the appended claims.

**[0025]** The foregoing description of the preferred embodiments of the invention has been presented for purposes of illustration and description only. It is not intended to be exhaustive, nor to limit the invention to the precise form disclosed; and obviously, many modification and variations are possible in

light of the above teaching. Such modifications and variations that may be apparent to a person skilled in the art are intended to be included within the scope of this invention as defined by the accompanying claims.

**TWIN-AXIAL WIRE ANTENNA**

**ABSTRACT OF THE DISCLOSURE**

An antenna includes a polymer coating having a VLF/LF element and an HF/VHF element embedded therein. A blocking choke is interposed between the VLF/LF element and the antenna feed to block HF/VHF signals. Small chokes are regularly positioned on the VLF/LF element to eliminate resonances caused by mutual capacitance between the elements. Reactive loads are positioned in said HF/VHF element at regular intervals for optimizing performance of the antenna in the HF/VHF radio bands. In further embodiments the antenna is provided as a floating antenna with the elements helically arranged therein.

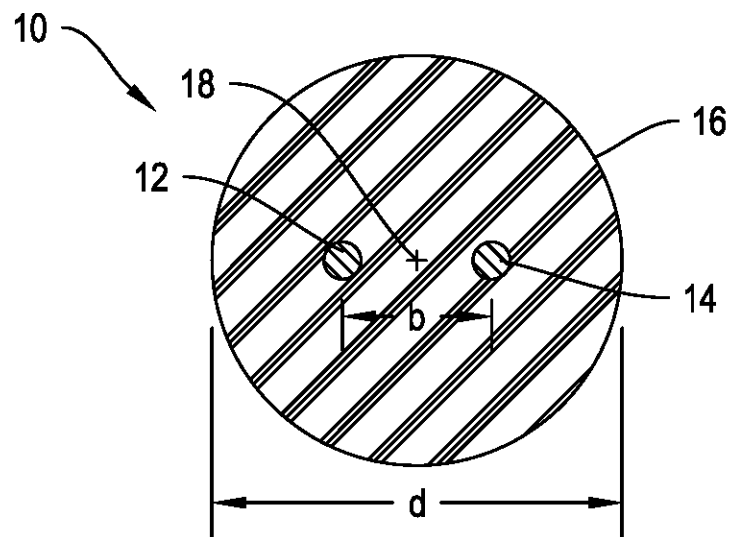

FIG. 1

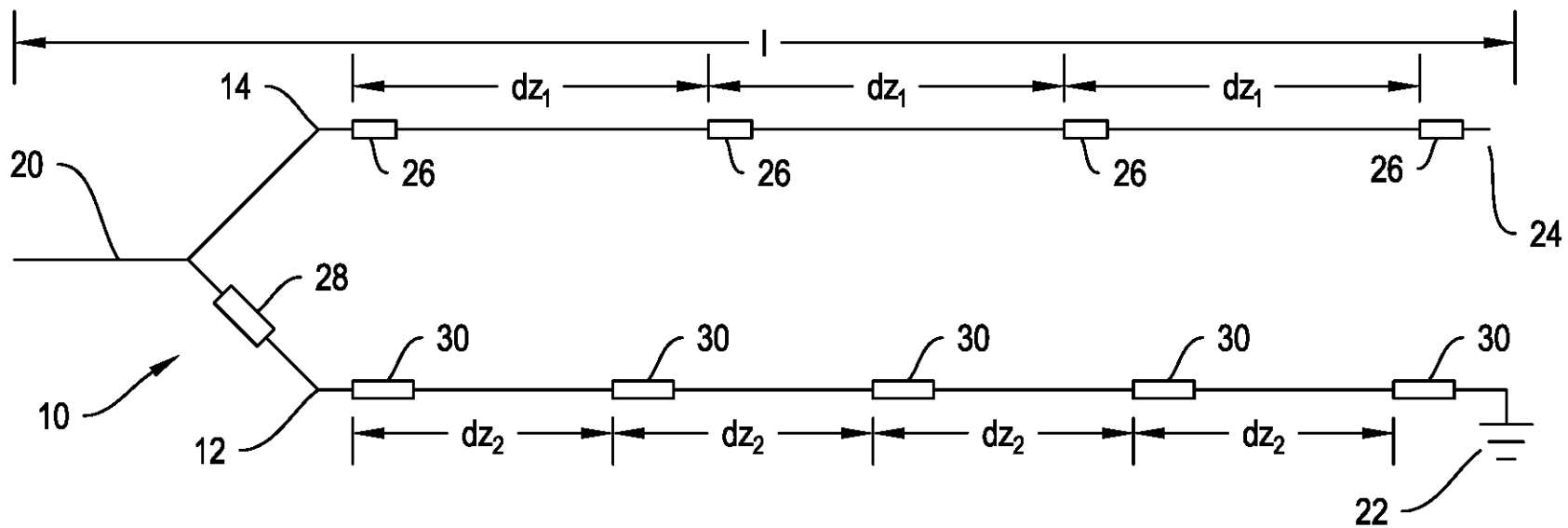

FIG. 2

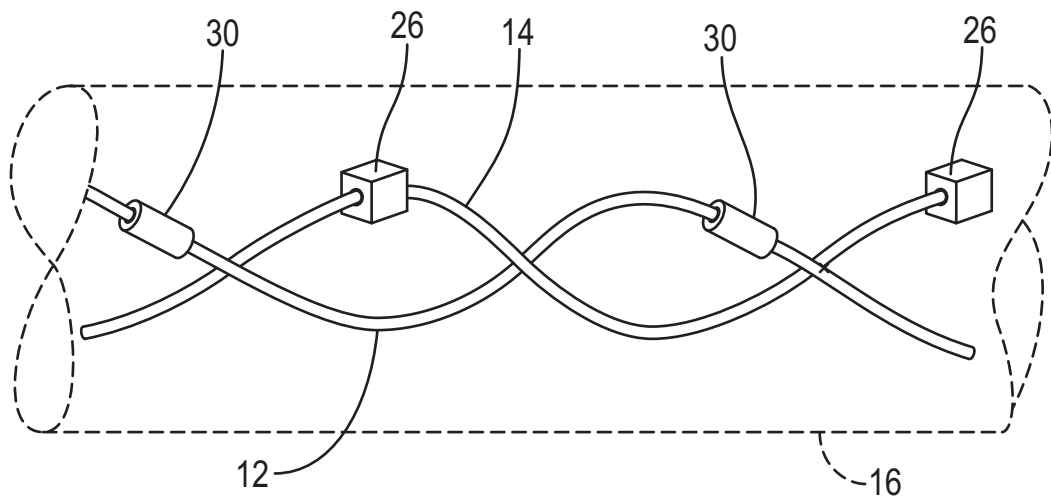

FIG. 3



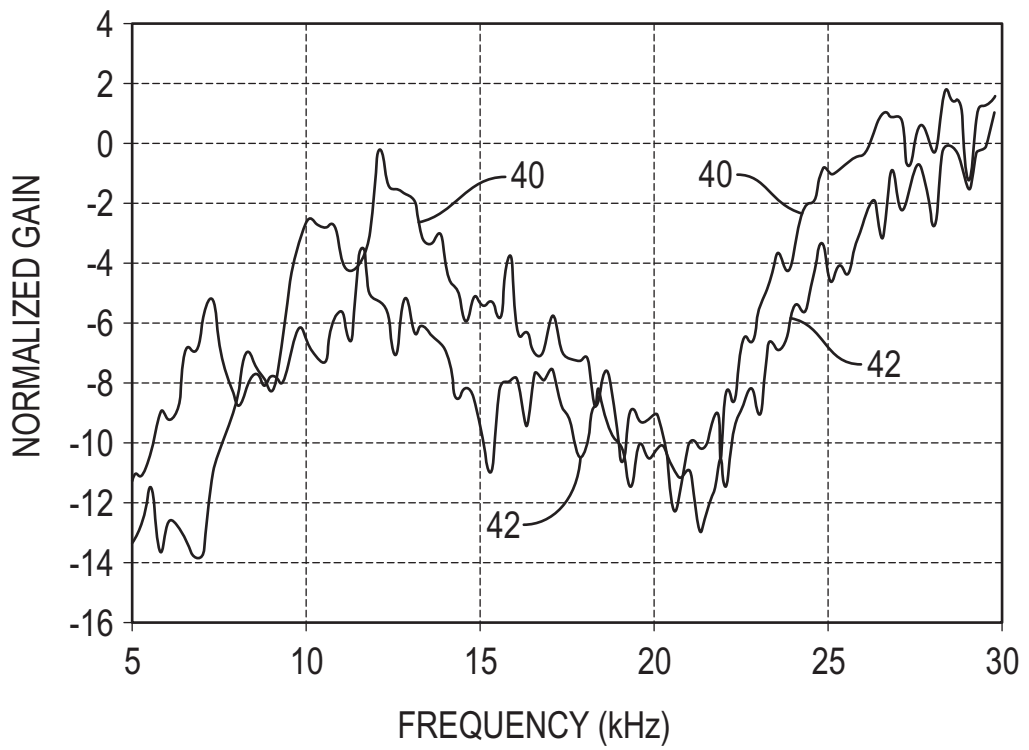

FIG. 4