



ARL-TN-0691 • Aug 2015



Simultaneous-Frequency Nonlinear Radar: Hardware Simulation

by Gregory J Mazzaro, Kenneth I Ranney, Kyle A Gallagher,
Sean F McGowan, and Anthony F Martone

Approved for public release; distribution unlimited.

NOTICES

Disclaimers

The findings in this report are not to be construed as an official Department of the Army position unless so designated by other authorized documents.

Citation of manufacturer's or trade names does not constitute an official endorsement or approval of the use thereof.

Destroy this report when it is no longer needed. Do not return it to the originator.



Simultaneous-Frequency Nonlinear Radar: Hardware Simulation

**by Gregory J Mazzaro, Kenneth I Ranney, Kyle A Gallagher,
Sean F McGowan, and Anthony F Martone**
Sensors and Electron Devices Directorate, ARL

REPORT DOCUMENTATION PAGE

Form Approved
OMB No. 0704-0188

Public reporting burden for this collection of information is estimated to average 1 hour per response, including the time for reviewing instructions, searching existing data sources, gathering and maintaining the data needed, and completing and reviewing the collection information. Send comments regarding this burden estimate or any other aspect of this collection of information, including suggestions for reducing the burden, to Department of Defense, Washington Headquarters Services, Directorate for Information Operations and Reports (0704-0188), 1215 Jefferson Davis Highway, Suite 1204, Arlington, VA 22202-4302. Respondents should be aware that notwithstanding any other provision of law, no person shall be subject to any penalty for failing to comply with a collection of information if it does not display a currently valid OMB control number.

PLEASE DO NOT RETURN YOUR FORM TO THE ABOVE ADDRESS.

1. REPORT DATE (DD-MM-YYYY) Aug 2015		2. REPORT TYPE Technical Note		3. DATES COVERED (From - To) 06/2015–08/2015	
4. TITLE AND SUBTITLE Simultaneous-Frequency Nonlinear Radar: Hardware Simulation				5a. CONTRACT NUMBER	
				5b. GRANT NUMBER	
				5c. PROGRAM ELEMENT NUMBER	
6. AUTHOR(S) Gregory J Mazzaro, Kenneth I Ranney, Kyle A Gallagher, Sean F McGowan, and Anthony F Martone				5d. PROJECT NUMBER	
				5e. TASK NUMBER	
				5f. WORK UNIT NUMBER	
7. PERFORMING ORGANIZATION NAME(S) AND ADDRESS(ES) US Army Research Laboratory ATTN: RDRL-SER-U 2800 Powder Mill Road Adelphi, MD 20783-1138				8. PERFORMING ORGANIZATION REPORT NUMBER ARL-TN-0691	
9. SPONSORING/MONITORING AGENCY NAME(S) AND ADDRESS(ES)				10. SPONSOR/MONITOR'S ACRONYM(S)	
				11. SPONSOR/MONITOR'S REPORT NUMBER(S)	
12. DISTRIBUTION/AVAILABILITY STATEMENT Approved for public release; distribution unlimited.					
13. SUPPLEMENTARY NOTES					
14. ABSTRACT A simultaneous-frequency nonlinear radar is presented for detecting radio frequency electronic targets of interest. The radar transmits 20 frequencies (“tones”) between 890 and 966 MHz, at approximately equal amplitudes and evenly spaced 4 MHz apart. The radar transceiver and the target are connected by coaxial cabling as a hardware simulation of a wireless channel. The radar receives intermodulation produced by these 20 frequencies, in a 90-MHz band just below 890 MHz and another 90-MHz band just above 966 MHz. An inverse Fourier transform of this intermodulation demonstrates successful detection and ranging of each electronic target at a distance (i.e., cable length) of just over 50 ft.					
15. SUBJECT TERMS nonlinear radar, intermodulation products, stepped frequency radar					
16. SECURITY CLASSIFICATION OF:			17. LIMITATION OF ABSTRACT UU	18. NUMBER OF PAGES 16	19a. NAME OF RESPONSIBLE PERSON Kenneth I Ranney
a. REPORT Unclassified	b. ABSTRACT Unclassified	c. THIS PAGE Unclassified			19b. TELEPHONE NUMBER (Include area code) (301) 394-0832

Contents

List of Figures	iv
1. Introduction	1
2. Experiment and Data	1
3. Conclusions	8
4. References	9
Distribution List	10

List of Figures

Fig. 1	A simultaneous-frequency radar that transmits at the frequencies f_1 and f_2 and receives the intermodulation frequencies $2f_1 - f_2$ and $2f_2 - f_1$	1
Fig. 2	Coaxial-line experiment to collect simultaneous-frequency data from nonlinear electronic targets of interest.....	2
Fig. 3	Targets: FV300 (left), T4500 (center), and connector in place of antenna (right).....	2
Fig. 4	Time-domain Tx and Rx waveforms for multitone experiment: the received waveform shown is from the Motorola FV300 radio.....	3
Fig. 5	Frequency-domain Tx and Rx waveforms: the received waveform is from the Motorola FV300 radio.....	4
Fig. 6	Received waveform from the FV300, filtered and processed via inverse FFT into the range profile waveform h_{IMD}	5
Fig. 7	Time-domain Tx and Rx waveforms for multitone experiment: the received waveform shown is from the Motorola T4500 radio	5
Fig. 8	Frequency-domain Tx and Rx waveforms: the received waveform is from the Motorola T4500 radio	6
Fig. 9	Received waveform from the T4500, filtered and processed via inverse FFT into the range profile waveform h_{IMD}	6
Fig. 10	Time-domain Tx and Rx waveforms for multitone experiment: the received waveform shown is from an open circuit at the end of the 51-ft cable.....	7
Fig. 11	Frequency-domain Tx and Rx waveforms: the received waveform is from the open circuit.....	7
Fig. 12	Received waveform from the open circuit, filtered and processed via inverse FFT into the range profile waveform h_{IMD}	8

1. Introduction

The nonlinear radar studied in this report transmits multiple simultaneous frequencies and receives intermodulation products in the vicinity of those same frequencies. This work is similar to that on intermodulation radar;¹⁻⁴ however, the simultaneous-frequency radar is wideband and allows for the generation of a range profile of the nonlinear radar environment.⁵⁻⁹

A 2-tone simultaneous-frequency radar is shown in Fig. 1. The radar transmits 2 frequencies, f_1 and f_2 , at (approximately) the same amplitude. The radar receives at least 2 intermodulation frequencies, $2f_1 - f_2$ and $2f_2 - f_1$. Although not depicted in Fig. 1, the radar may also receive higher-order intermodulation frequencies such as $3f_1 - 2f_2$ and $3f_2 - 2f_1$. The current experimental radar transmits 20 simultaneous frequencies and receives enough (higher-order) intermodulation products to adequately construct a range profile over more than 100 ft.

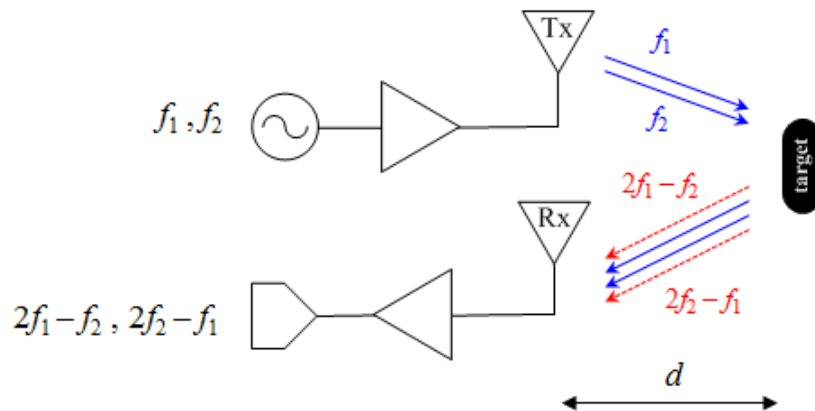

Fig. 1 A simultaneous-frequency radar that transmits at the frequencies f_1 and f_2 and receives the intermodulation frequencies $2f_1 - f_2$ and $2f_2 - f_1$

2. Experiment and Data

The experiment used to collect simultaneous-frequency data is depicted in Fig. 2. The radar environment is currently simulated in hardware using 51 ft of Megaphase F130 cable to mimic transmission over the air from the radar to an electronic target and reflection over the air back to the radar. The target is a radio that has been connectorized (i.e., its antenna was removed and replaced with an SMA end-launch connector).

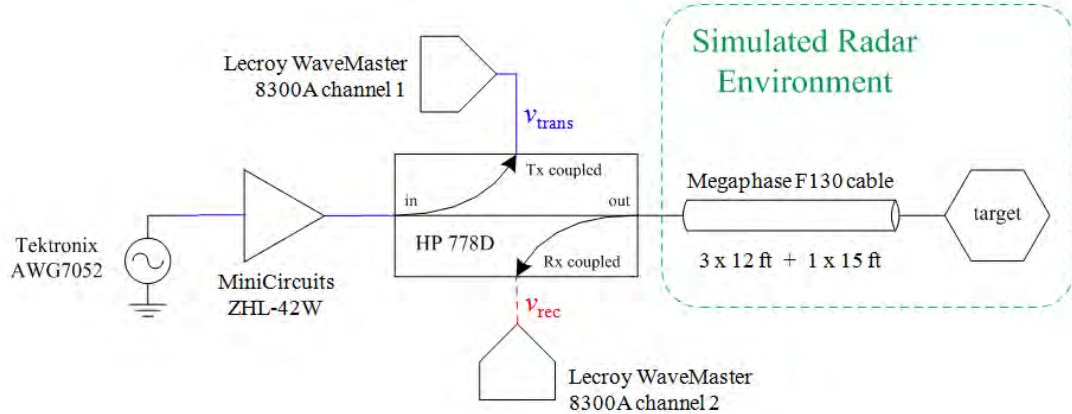

Fig. 2 Coaxial-line experiment to collect simultaneous-frequency data from nonlinear electronic targets of interest

The transmitted signal source is the Tektronix AWG7052 arbitrary waveform generator. The MiniCircuits ZHL-42W amplifies this signal by 38 dB before it is input to the Hewlett-Packard 778D dual-directional coupler. The output of the HP 778D feeds into 51 ft of low-loss, low-distortion Megaphase F130 cable (three 12-ft lengths plus one 15-ft length in cascade). At the end of the 51-ft cable is the connectorized target. Data was collected from 2 targets: the Motorola FV300 and the Motorola T4500 (handheld radios). Photos of these 2 targets and a zoomed-in view of the connectorized FV300 are given in Fig. 3.



Fig. 3 Targets: FV300 (left), T4500 (center), and connector in place of antenna (right)

The output from the AWG7052 contains $N = 20$ simultaneous frequencies.¹⁰ The lowest frequency is $f_{start} = 890$ MHz. The highest frequency is $f_{end} = 966$ MHz. The frequencies are evenly spaced by $\Delta f = 4$ MHz. The output power is -54 dBm/frequency (-41 dBm total).

The voltage wave that reflects from the target is separated from the wave transmitted to the target by the directional coupler. The transmit (Tx) and receive (Rx) waveforms are sampled at 20 dB down from their true amplitudes via the Tx- and Rx-coupled ports on the 778D. These sampled waveforms are captured by the

Lecroy Wavemaster 8300A digitizing oscilloscope; channel 1 captures v_{trans} and channel 2 captures v_{rec} . A fast Fourier transform (FFT) computed in Matlab is used to view the time-domain-captured waveforms in the frequency domain.

Figure 4 contains the time-domain transmitted and received waveforms for the Motorola FV300 as the target. Figure 5 contains the frequency-domain versions of these same waveforms. The transmit waveform contains a significant amount of intermodulation (below 890 MHz and above 966 MHz), which can be traced to the output from the AWG. For this wireline experiment, the current level of transmitter-generated intermodulation is not prohibitive. For a wireless experiment, this intermodulation should be minimized using pre-distortion or feedforward cancellation (because the received intermodulation, which is expected to be much weaker in the wireless case, is likely to be masked by the transmitter-generated intermodulation).

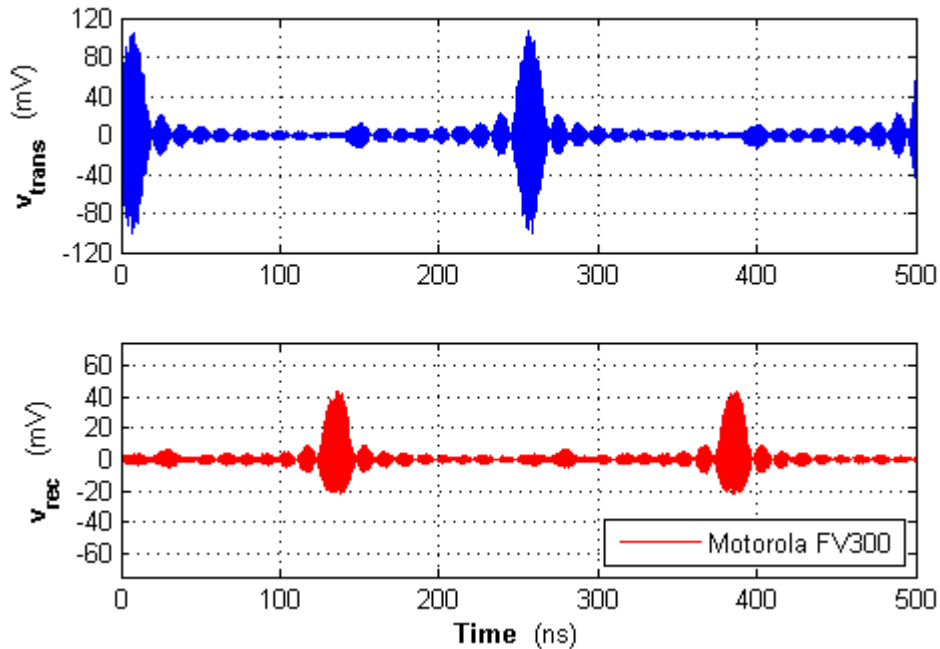

Fig. 4 Time-domain Tx and Rx waveforms for multitone experiment: the received waveform shown is from the Motorola FV300 radio

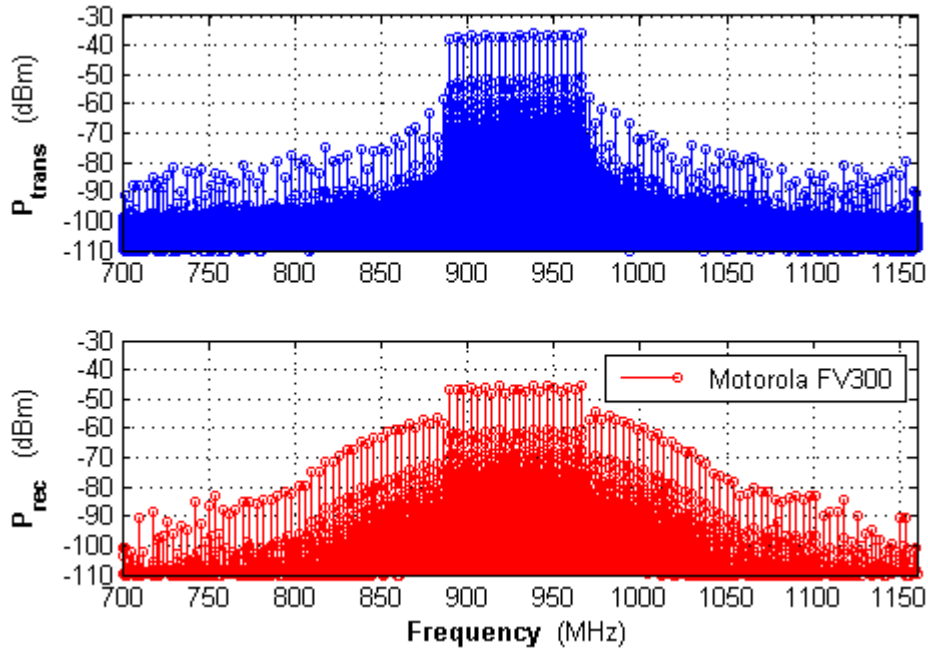

Fig. 5 Frequency-domain Tx and Rx waveforms: the received waveform is from the Motorola FV300 radio

The received waveform contains intermodulation generated by the target (particularly in the ranges 800–886 and 970–1060 MHz, and relative to the power at the intended 20 transmit frequencies). In the upper part of Fig. 6, the target-generated intermodulation is isolated from target’s linear response by band-stop filtering v_{rec} between 890 and 966 MHz. An inverse FFT^{6,8} of this filtered v_{rec} , whose horizontal axis is scaled from time to distance by $d = u_p t / 2$, is given in the lower part of Fig. 6 as h_{IMD} . The propagation speed used for this calculation is that reported by the cable manufacturer: $1/u_p = 1.27 \text{ ns/ft}$.¹¹

Figures 7–9 are the same as Figs. 4–6 but for the T4500 radio as the target instead of the FV300. Figures 10–12 are the corresponding data traces for an open circuit located at the end of the 51-ft cable instead of an actual target.

The waveforms h_{IMD} in Figs. 6 and 9 display a maximum at $d = 53 \text{ ft}$, corresponding to the length of the cascaded Megaphase cables, plus an extra 2 ft due to the length of the 778D coupler and each cable between the coupler and the oscilloscope. Compared to the “no-target case,” i.e., the open-circuit data in Fig. 12, the presence of a well-defined peak indicates successful detection of each nonlinear target. The location of the peak at a distance d corresponding to the physical length of the coaxial line between the radar transceiver and the target indicates successful ranging of each nonlinear target. Simultaneous-frequency radar, for 20 tones and transmit frequencies between 890 and 966 MHz, has been successfully

demonstrated via wireline. A follow-up experiment will replace the “simulated radar environment” of Fig. 2 by a fully wireless transmit/receive channel.

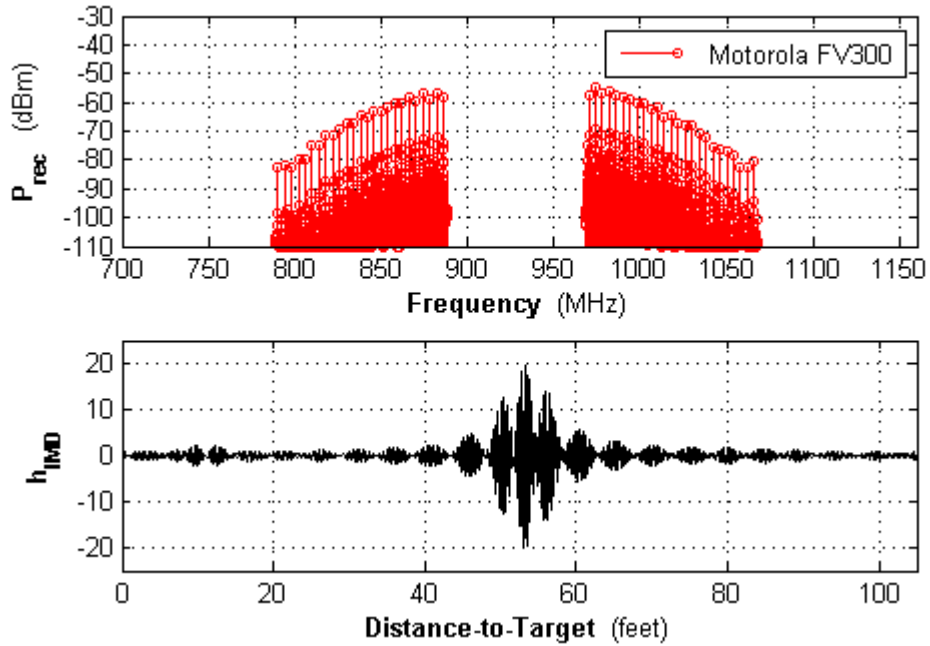

Fig. 6 Received waveform from the FV300, filtered and processed via inverse FFT into the range profile waveform h_{IMD}

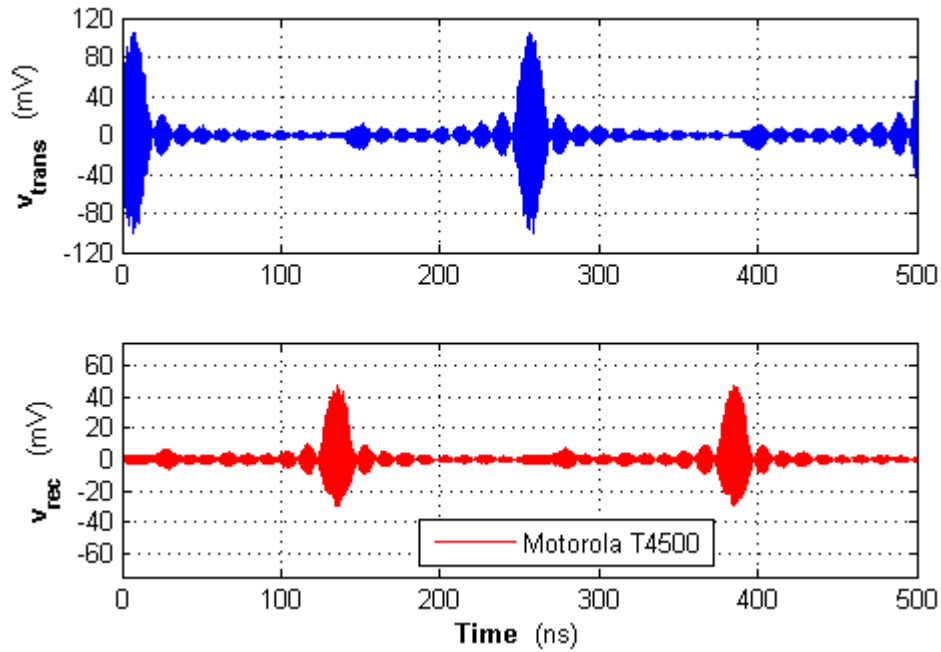

Fig. 7 Time-domain Tx and Rx waveforms for multitone experiment: the received waveform shown is from the Motorola T4500 radio

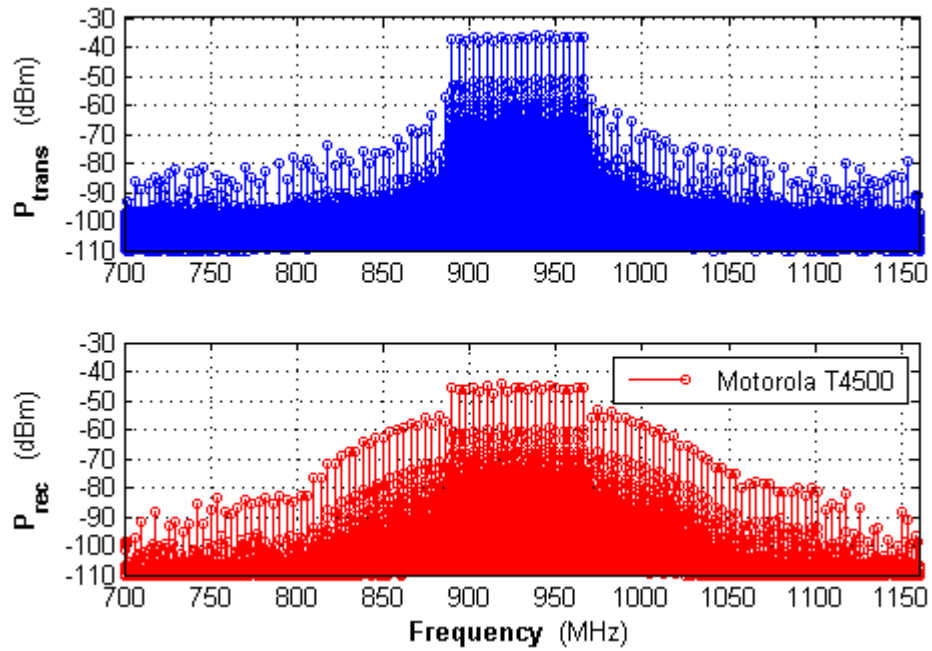

Fig. 8 Frequency-domain Tx and Rx waveforms: the received waveform is from the Motorola T4500 radio

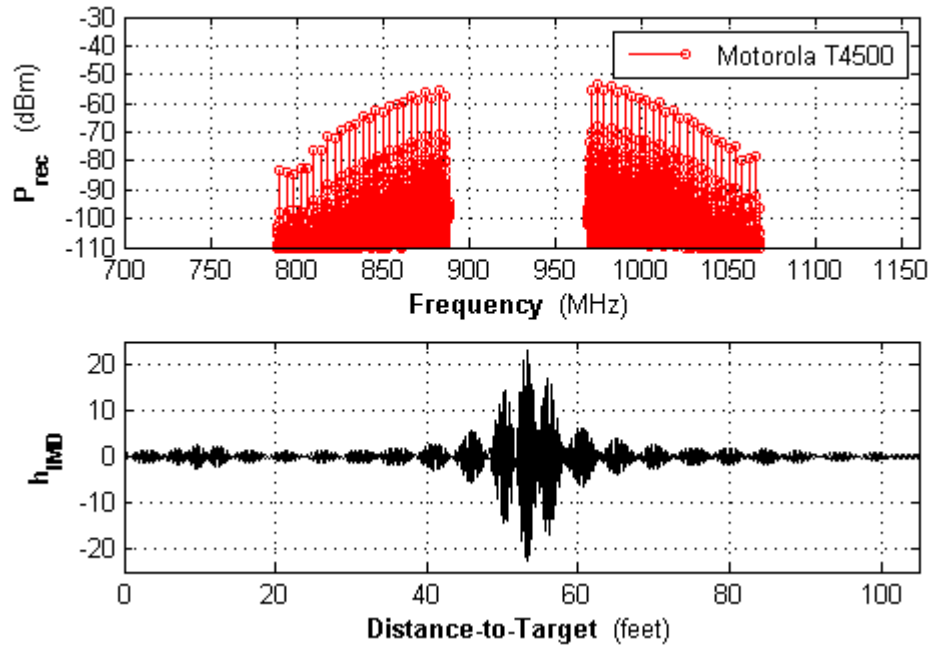

Fig. 9 Received waveform from the T4500, filtered and processed via inverse FFT into the range profile waveform h_{IMD}

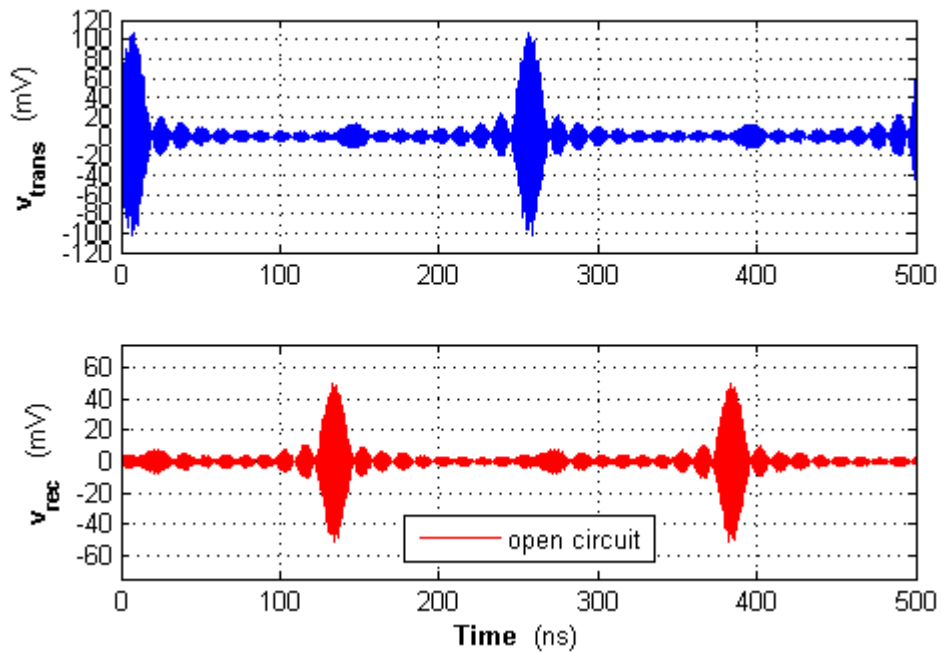

Fig. 10 Time-domain Tx and Rx waveforms for multitone experiment: the received waveform shown is from an open circuit at the end of the 51-ft cable

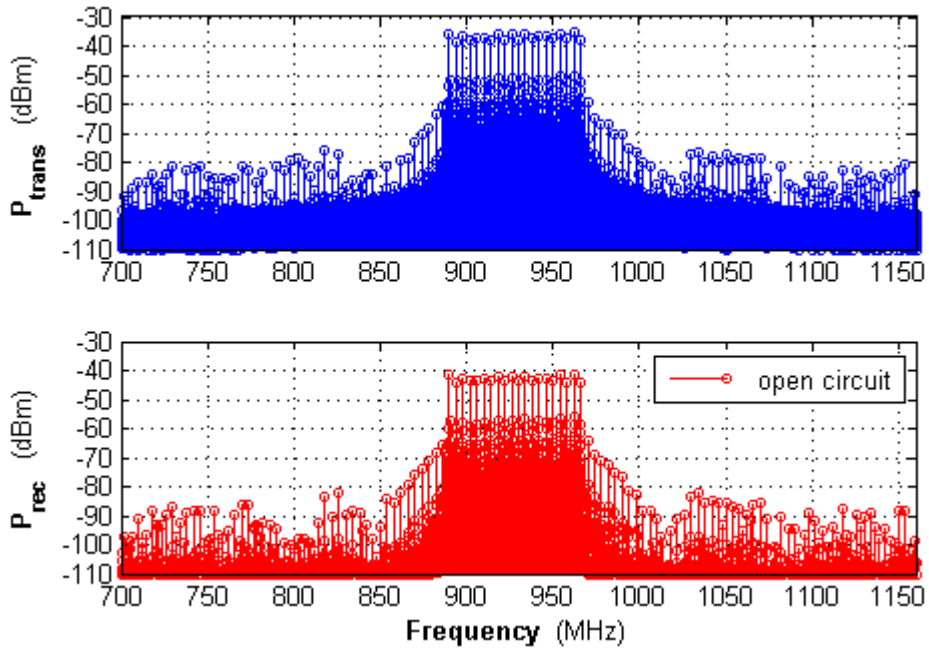

Fig. 11 Frequency-domain Tx and Rx waveforms: the received waveform is from the open circuit

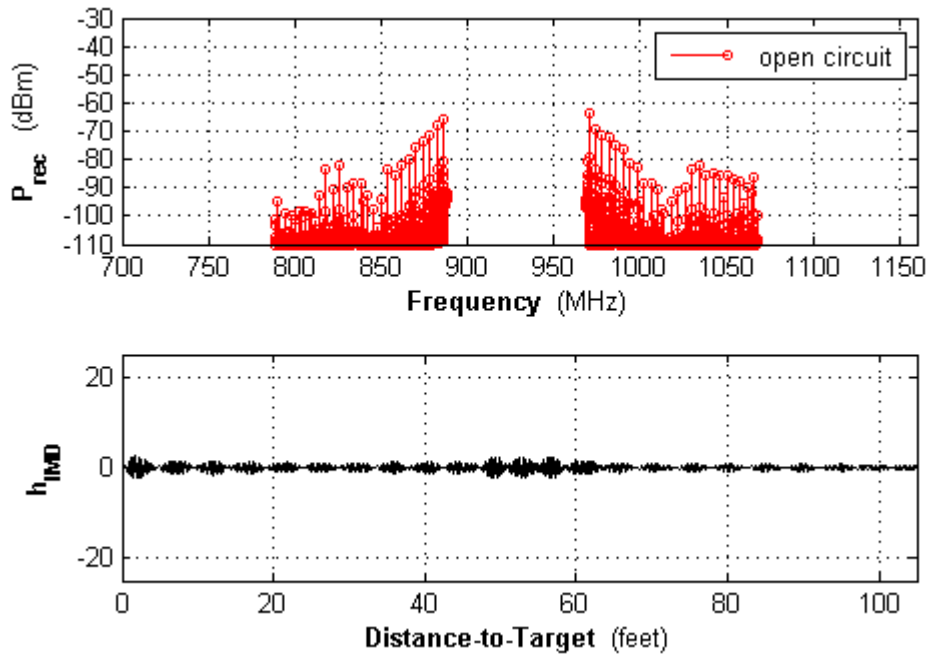

Fig. 12 Received waveform from the open circuit, filtered and processed via inverse FFT into the range profile waveform h_{IMD}

3. Conclusions

Simultaneous-frequency nonlinear radar was successfully demonstrated for 20 transmitted tones, evenly spaced between 890 and 966 MHz, for 2 electronic targets of interest, at a distance of just over 50 ft, by receiving and processing intermodulation generated by each target. The wireline experiment implies that the results may be extended to a well-controlled (high transmit power, low noise, short-range) wireless test. True standoff radar operation must be confirmed by replacing the wireline channel (coaxial line) with a fully wireless channel (over the air).

4. References

1. Saebboe J, et al. Harmonic automotive radar for VRU classification. Proceedings of the International Radar Conference; pp. 1–5, Oct. 2009.
2. Martone AF, Delp EJ. Characterization of RF devices using two-tone probe signals. Proceedings of the 14th Workshop on Statistical Signal Processing, pp. 161–165, Aug. 2007.
3. Lyons RG. Signal and interference output of a bandpass nonlinearity. IEEE Transactions on Communication, 1979 June;27(6):888–891.
4. Walker AL, Buff PM. Method and apparatus for remote detection of radio-frequency devices. US Patent 8,131,239, Mar. 6, 2012.
5. Phelan BR, Ressler MA, Mazzaro GJ, Sherbondy KD, Narayanan RM. Design of spectrally versatile forward-looking ground-penetrating radar for detection of concealed targets. Proceedings of the SPIE. 2013 May;8714:87140B(1–10).
6. Mazzaro GJ, Gallagher KA, Martone AF, Narayanan RM. Stepped-frequency nonlinear radar simulation. Proceedings of the SPIE 2014 May;9077:90770U(1–10).
7. Gallagher KA, Mazzaro GJ, Ranney KI, Nguyen Lam H, Sherbondy KD, Narayanan RM. Nonlinear synthetic aperture radar imaging using a harmonic radar. Proceedings of the SPIE. 2015 Apr;9461:946109(1–11).
8. Mazzaro GJ, Gallagher KA, Martone AF, Sherbondy KD, Narayanan RM. Short-range harmonic radar: Chirp waveform, electronic targets. Proceedings of the SPIE. 2015 Apr;9461:946108(1–12).
9. Gallagher KA, Narayanan RM, Mazzaro GJ, Ranney KI, Martone AF, Sherbondy KD. Moving target indication with non-linear radar. Proceedings of the IEEE Radar Conference. 2015 May:1428–1433.
10. Ranney K, Gallagher K, Martone A, Mazzaro G, Sherbondy K, Narayanan R. Instantaneous, stepped-frequency nonlinear radar. Proceedings of the SPIE. 2015 Apr;9461:946122(1–8).
11. “GrooveTube cables: Time delay: 1 & 2 Series,” Megaphase product datasheet, www.megaphase.com, 2011.

1 DEFENSE TECH INFO CTR
(PDF) DTIC OCA

2 US ARMY RSRCH LAB
(PDF) IMAL HRA MAIL & RECORDS MGMT
RDRL CIO LL TECHL LIB

1 GOVT PRNTG OFC
(PDF) A MALHOTRA

10 US ARMY RSRCH LAB
(PDF) RDRL SER U
A MARTONE
A SULLIVAN
D LIAO
D MCNAMARA
G SMITH
K RANNEY
K SHERBONDY
M HIGGINS
M RESSLER
T DOGARU

1 THE CITADEL
(PDF) DEPT OF ELEC & COMP ENG
G MAZZARO