

The public reporting burden for this collection of information is estimated to average 1 hour per response, including the time for reviewing instructions, searching existing data sources, gathering and maintaining the data needed, and completing and reviewing the collection of information. Send comments regarding this burden estimate or any other aspect of this collection of information, including suggestions for reducing this burden, to Washington Headquarters Services, Directorate for Information Operations and Reports, 1215 Jefferson Davis Highway, Suite 1204, Arlington VA, 22202-4302. Respondents should be aware that notwithstanding any other provision of law, no person shall be subject to any penalty for failing to comply with a collection of information if it does not display a currently valid OMB control number.
PLEASE DO NOT RETURN YOUR FORM TO THE ABOVE ADDRESS.

1. REPORT DATE (DD-MM-YYYY) 26-09-2014	2. REPORT TYPE Final Report	3. DATES COVERED (From - To) 7-Apr-2011 - 6-Aug-2014
---	--------------------------------	---

4. TITLE AND SUBTITLE Final Report: Self-Contained Automated Vehicle Washing System	5a. CONTRACT NUMBER
	5b. GRANT NUMBER W911NF-11-C-0084
	5c. PROGRAM ELEMENT NUMBER 506043

6. AUTHORS Richard Gross PI, Barbara Gross Adm.	5d. PROJECT NUMBER
	5e. TASK NUMBER
	5f. WORK UNIT NUMBER

7. PERFORMING ORGANIZATION NAMES AND ADDRESSES Octaflex Environmental Systems, Inc. PO Box 404 709 E Street Timber Lake, SD 57656 -0404	8. PERFORMING ORGANIZATION REPORT NUMBER
---	--

9. SPONSORING/MONITORING AGENCY NAME(S) AND ADDRESS (ES) U.S. Army Research Office P.O. Box 12211 Research Triangle Park, NC 27709-2211	10. SPONSOR/MONITOR'S ACRONYM(S) ARO
	11. SPONSOR/MONITOR'S REPORT NUMBER(S) 58526-CH-SB3.1

12. DISTRIBUTION AVAILABILITY STATEMENT Approved for Public Release; Distribution Unlimited
--

13. SUPPLEMENTARY NOTES The views, opinions and/or findings contained in this report are those of the author(s) and should not be construed as an official Department of the Army position, policy or decision, unless so designated by other documentation.

14. ABSTRACT The Self Contained Automated Vehicle Washing System is a prototype that offers a reduction in the quantity of water supplied to the front lines by recycling wash water used in the cleaning of vehicles as well as capturing debris and other contaminants. The system also responds to the need of portability. In addition to efficient cleaning of military vehicles and logistical equipment the system reduces the exposure of the warfighter to contaminants in the washing process. The System offers plug and play option for reclamation of the wash water and integration of anti-corrosion application.

15. SUBJECT TERMS portable wash system, water efficient, labor efficient, environmentally friendly, ease of use
--

16. SECURITY CLASSIFICATION OF:	17. LIMITATION OF ABSTRACT	15. NUMBER OF PAGES	19a. NAME OF RESPONSIBLE PERSON Richard Gross
a. REPORT UU	b. ABSTRACT UU	c. THIS PAGE UU	19b. TELEPHONE NUMBER 605-865-3481

Report Title

Final Report: Self-Contained Automated Vehicle Washing System

ABSTRACT

The Self Contained Automated Vehicle Washing System is a prototype that offers a reduction in the quantity of water supplied to the front lines by recycling wash water used in the cleaning of vehicles as well as capturing debris and other contaminants. The system also responds to the need of portability. In addition to efficient cleaning of military vehicles and logistical equipment the system reduces the exposure of the warfighter to contaminants in the washing process. The System offers plug and play option for reclamation of the wash water and integration of anti-corrosion application.

Enter List of papers submitted or published that acknowledge ARO support from the start of the project to the date of this printing. List the papers, including journal references, in the following categories:

(a) Papers published in peer-reviewed journals (N/A for none)

Received Paper

TOTAL:

Number of Papers published in peer-reviewed journals:

(b) Papers published in non-peer-reviewed journals (N/A for none)

Received Paper

TOTAL:

Number of Papers published in non peer-reviewed journals:

(c) Presentations

Number of Presentations: 0.00

Non Peer-Reviewed Conference Proceeding publications (other than abstracts):

Received Paper

TOTAL:

Number of Non Peer-Reviewed Conference Proceeding publications (other than abstracts):

Peer-Reviewed Conference Proceeding publications (other than abstracts):

Received Paper

TOTAL:

Number of Peer-Reviewed Conference Proceeding publications (other than abstracts):

(d) Manuscripts

Received Paper

TOTAL:

Number of Manuscripts:

Books

Received Book

TOTAL:

Received

Book Chapter

TOTAL:

Patents Submitted

Patents Awarded

Awards

Graduate Students

<u>NAME</u>	<u>PERCENT SUPPORTED</u>
FTE Equivalent:	
Total Number:	

Names of Post Doctorates

<u>NAME</u>	<u>PERCENT SUPPORTED</u>
FTE Equivalent:	
Total Number:	

Names of Faculty Supported

<u>NAME</u>	<u>PERCENT SUPPORTED</u>
FTE Equivalent:	
Total Number:	

Names of Under Graduate students supported

<u>NAME</u>	<u>PERCENT SUPPORTED</u>
FTE Equivalent:	
Total Number:	

Student Metrics

This section only applies to graduating undergraduates supported by this agreement in this reporting period

The number of undergraduates funded by this agreement who graduated during this period: 0.00

The number of undergraduates funded by this agreement who graduated during this period with a degree in science, mathematics, engineering, or technology fields:..... 0.00

The number of undergraduates funded by your agreement who graduated during this period and will continue to pursue a graduate or Ph.D. degree in science, mathematics, engineering, or technology fields:..... 0.00

Number of graduating undergraduates who achieved a 3.5 GPA to 4.0 (4.0 max scale):..... 0.00

Number of graduating undergraduates funded by a DoD funded Center of Excellence grant for Education, Research and Engineering:..... 0.00

The number of undergraduates funded by your agreement who graduated during this period and intend to work for the Department of Defense 0.00

The number of undergraduates funded by your agreement who graduated during this period and will receive scholarships or fellowships for further studies in science, mathematics, engineering or technology fields:..... 0.00

Names of Personnel receiving masters degrees

<u>NAME</u>
Total Number:

Names of personnel receiving PHDs

<u>NAME</u>
Total Number:

Names of other research staff

<u>NAME</u>	<u>PERCENT SUPPORTED</u>
FTE Equivalent:	
Total Number:	

Sub Contractors (DD882)

Inventions (DD882)

Scientific Progress

Technology Transfer



Self Contained Automated Vehicle Washing System

ARO Final Report
Navy Topic: N97-001
Contract: W911NF-11-C-0084

Submitted to: Dr. Jennifer Becker, JPM
U.S. Army Research Office
4300 South Miami Blvd
Durham, NC 27703-9142

Submitted by: Richard Gross, PI
709 E Street
Timber Lake, SD 57656

Identification and Significance of a Large Vehicle Wash System (LVWS)

Background

Federal and state regulations on the handling of hazardous materials and the transportation of equipment or materials that have been used in a foreign environment are becoming more stringent. The Department of Defense has implemented and continues to implement new requirements on the "Washdown" or "Decontamination" of equipment after its use both on foreign soil as well as the United States. Combat vehicles must be completely decontaminated to eliminate threats to the health and safety of military personnel. This necessitates a portable, field deployable, self-contained washing system that allows the re-use of water.

Reducing the quantity of water supplied to the front lines by recycling wash water reduces the demand on the logistics system, leading to economic and other benefits. The logistics benefits combined with the need to safeguard military personnel from harmful contaminants are the impetus for designing a closed loop vehicle washing system.

Systems Specification Development

This Statement of Work is in support of Legislative Defense Appropriation: Self-Contained Automated Vehicle Wash System. The objective is to further enhance properties of the OctaFlex Large Vehicle Wash System (LVWS) by improving wash down safety for the war fighter and utilizing collection bays for capture of debris and other contaminants for disposal. The wash facility features:

- Portability
- Functionality, ease of use
- Maintain minimal impact on environment and logistic concerns
- Capture debris and other contaminants for disposal
- Reduce exposure of the war fighter to contaminants in the vehicle washing process
- The wash system is capable of supporting military vehicles currently in use
- Remove dirt, mud and debris from the vehicle including undercarriage
- Wash bay is constructed using commercial off the shelf equipment (COTs)
- Increase efficiency
- Capable of operating with or without reclamation system using plug and play design
- Cleaning of logistical equipment other than vehicles
- Wash system is operational by warfighter in MOPP 4 protective gear
- System is capable of being decontaminated with bleach solution
- Disassembled and repackaged for shipping by warfighter in MOPP 4 gear
- Easy access for warfighter in MOPP 4 gear to clean out mud and debris using hand tools
- System is capable of the integration of an anti-corrosion application

Technology Description

Description of Wash Facility: This system is based on four platforms, a wash station, a reclamation station; a pumping station and an electrical supply station all being capable of transport on a standard flat bed trailer. The total water capacity of the entire system, which includes the wash bay, reclamation and pumping stations, is 8,850 gallons. Although the system is designed to run on much less than that, 4000 gallons, with this capacity it allows for more water to be available to the pump station for longer periods of operation.

The pump station is capable of a combined flow of 1300 gpm divided amongst a four section wash station. The first station includes an integrated cross section under carriage wash, discharging water at 175gpm with a pressure of 250 psi. The second station consists of two, self storing, spray towers ten foot tall discharging 250gpm each, with a pressure of 100psi, as well as an under carriage wash. The third station is identical to the second station, equipped with two side towers and an under carriage wash.

The fourth and final station is the final rinse station. This bay is equipped with a collapsible, self storing over head spray rack, discharging water at 125gpm with a pressure of 300psi. All bays of the wash station are equipped with collapsible deflection shields that are easily secured into position, thus making the only open areas being the top, the entrance and the exit openings.

The system receives its power from the electric supply station which is equipped with a 250KW generator, 200 gallon fuel tank and a control panel.

This system is capable of reclaiming, through a 5000 lb activated carbon filter at a flow of 300 gpm.

The entire wash system can be set up and operational with a trained crew in an estimated four hour period; decontaminated, disassembled and repackaged in an estimated six hour timeframe. Estimated man power to assemble the system once it is on the ground is six personnel. Estimated man power to operate the system is two personnel. Estimated man power to disassemble, decontaminate and repackage the system is six personnel. This system is capable of processing fifteen- thirty foot long vehicles in approximately one hour depending on degree of soil.

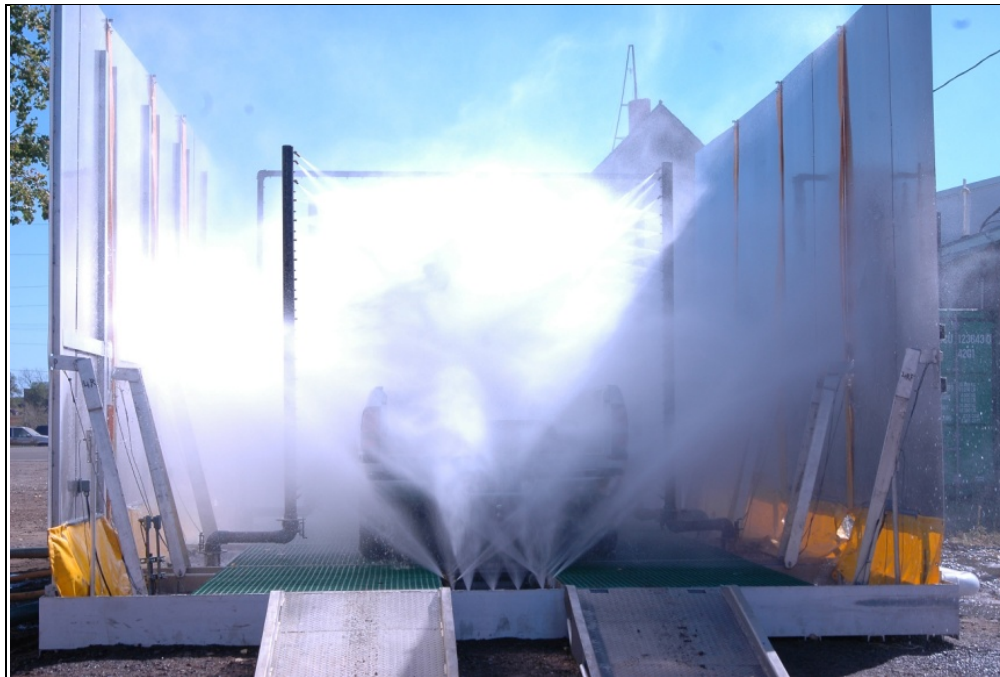

Self Contained Automated Vehicle Washing System

Onsite Demonstration of Prototype to ARO at OctaFlex production facility



ARO Personnel viewing the Wash System in operation and Pump Station

Self Contained Vehicle Washing System Specification

Side Tower Water Flow: GPM=250 gpm each
PSI= 100 psi each

Undercarriage Wash: GPM= 175 gpm
PSI= 250 psi each

Overhead Rinse: GPM= 125 gpm
PSI= 300 psi

Water Storage Tank Capacity: 5,250 gal.

Wash Deck Capacity: 3,600 gal.

Generator Size: 250K with sound enclosure

Carbon Filter Capacity: 5,000 lb. coconut based activated carbon with a cleaning rate of 300 gpm

Pump Station Control Panel is fully customizable in regards to run times, run sequence and pressures.

Chemical Injection is available on the suction side of the side tower pump

Assembly time: 4 hours to completion

Spray Angle and spray distance are adjustable in approximately two inch increments

Side Towers are mobile and travel parallel to the vehicle

Run time is approximately 13 minutes; majority of this time is needed for reclamation, and larger return pumps would speed this up.

All bays self level through a six inch connection

One sensor controls the entire wash system.

Operating Position

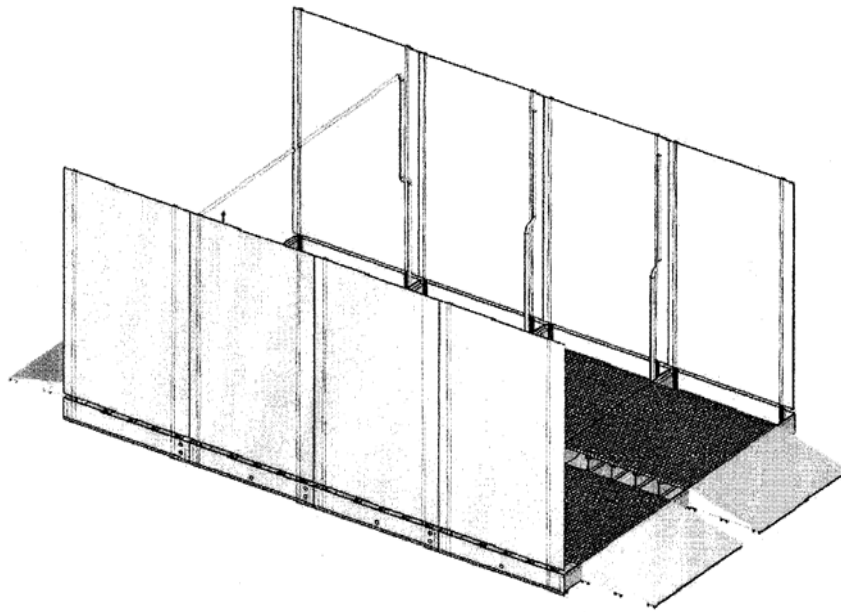

Transport Position

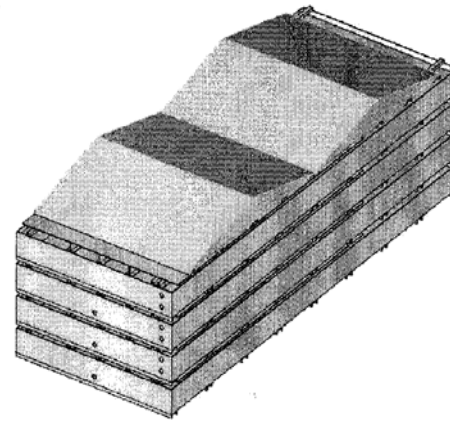

Shipping Position

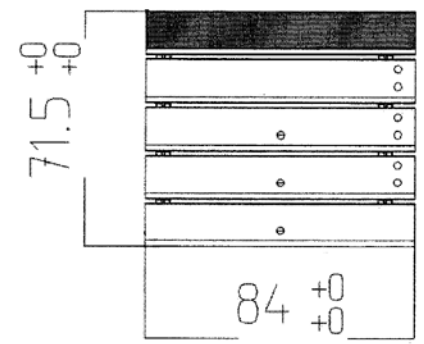
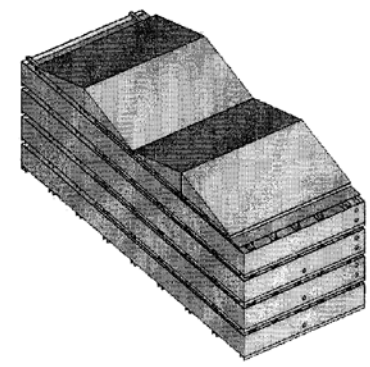
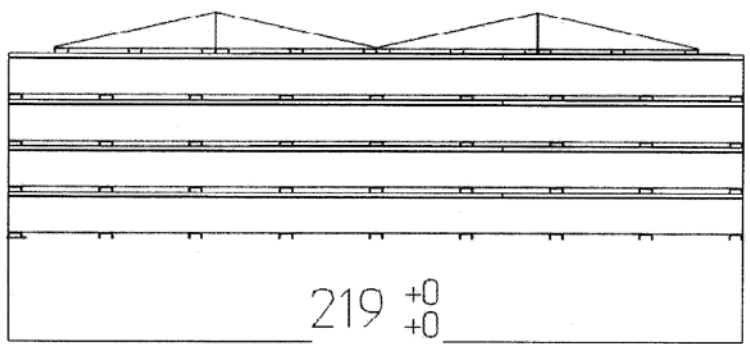
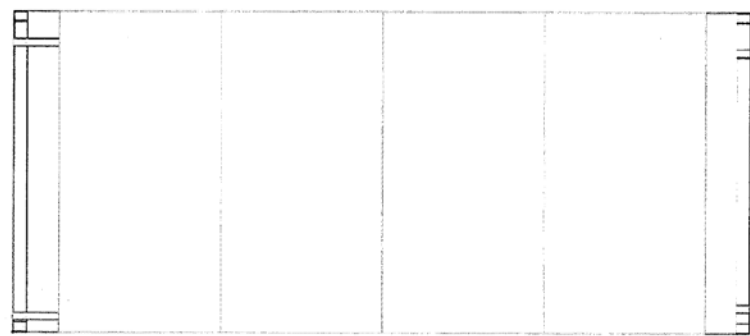

Operating Position

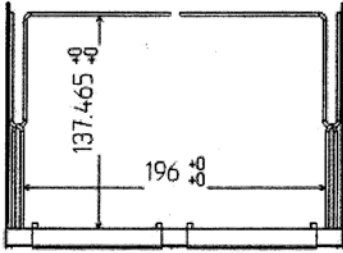
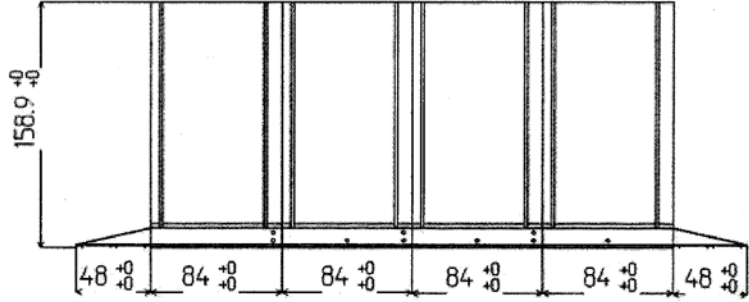
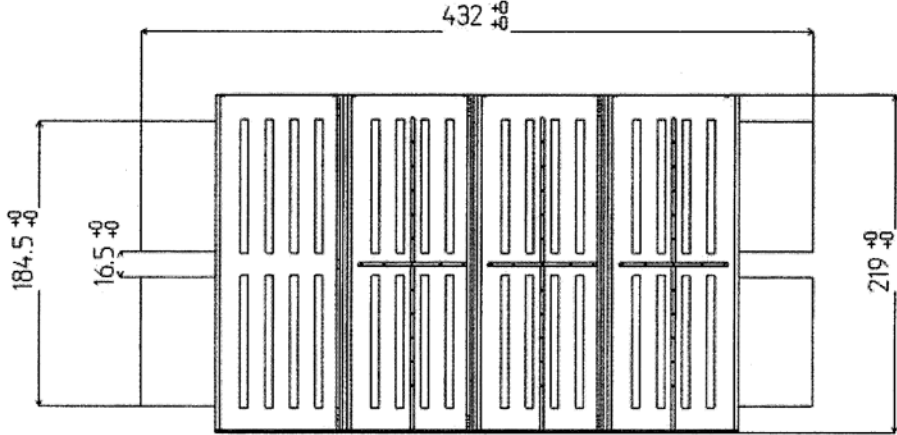

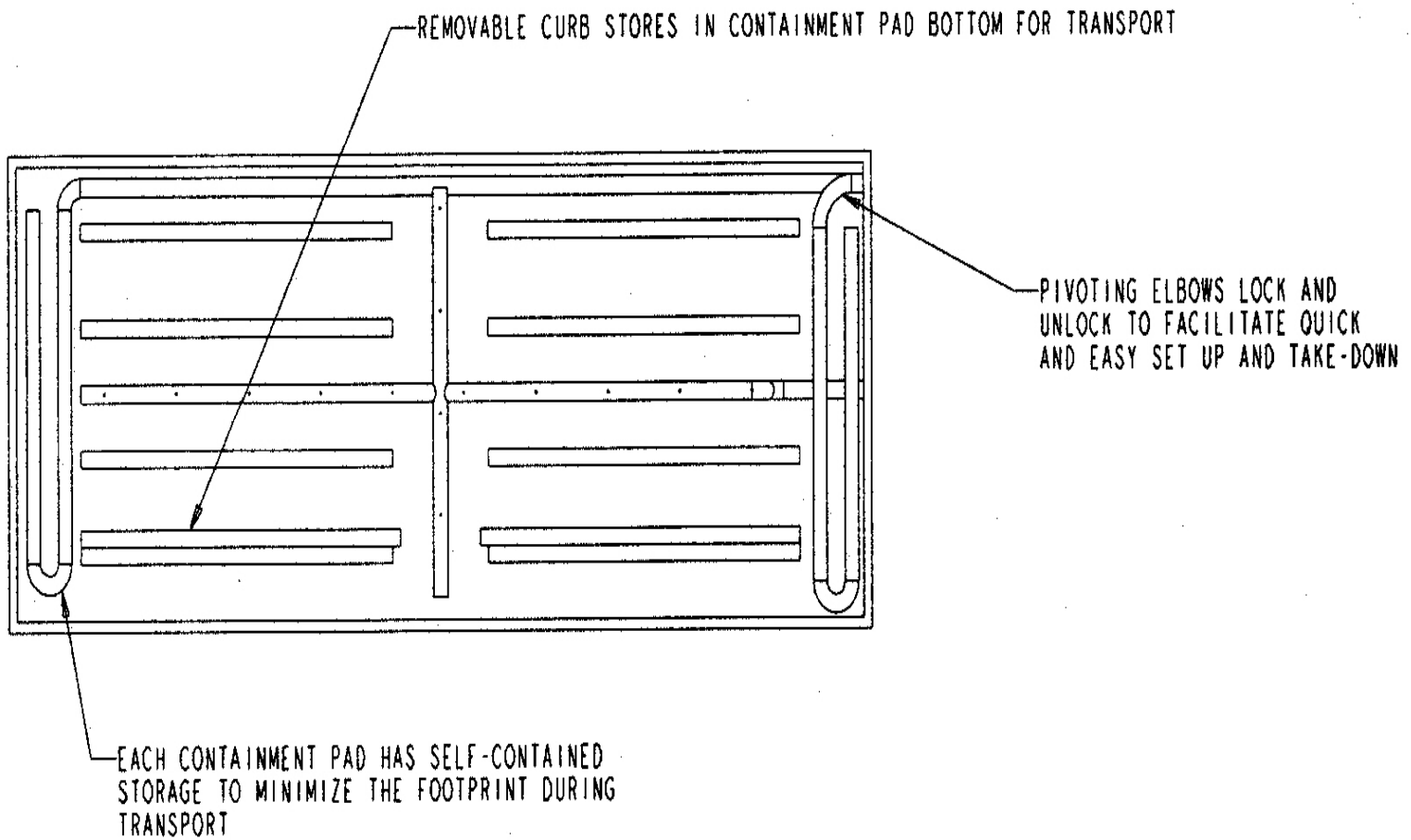

Over Head Wash

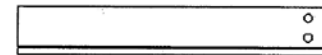
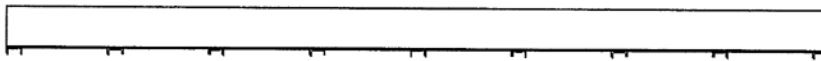
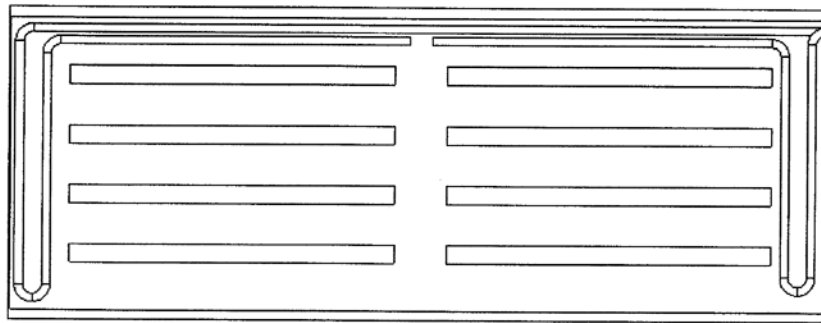

Deliverables

The Self Contained Automated Vehicle Washing System was shipped to Dugway, UT in August 2013 and travel plans were confirmed only to encounter the government shutdown which would delay travel until 2014.

In May 2014 OctaFlex Environmental Systems traveled to Dugway Proving Grounds, Dugway, UT to assemble and train personnel on the Self-Contained Automated Vehicle Washing System. The OES personnel assembled and operated the system and successfully demonstrated multiple times to various groups including the company of the commanding officer of Dugway, Dr. Jennifer Becker, JPM US Army Research Office, Dr. Stephan Lee, Chief Scientist, US Army Research and Bill Davis, US Army ATEC. Video and photo documentation of the demonstration and disassembly process was performed by Dugway personnel. The Washing System prototype is currently stored in shipping containers at Dugway.

Commercialization/Procurement Comments

“The system would be excellent for rapidly processing large numbers of vehicles, material, equipment, small aircraft, small boats, and even personnel. For example, the use of the washdown system would save the run time and wear on deployed TOE unit decontamination equipment and personnel that would potentially be required to clean vehicles prior to return from OEF/OIF. The recycle of washdown liquid could potentially eliminate the 485,000 gals/day of liquid (salt water) reportedly used to wash down vehicles prior to return to the U.S. after ODS/ODS FASO, minimal personal involvement.”

“As currently configured, 2-5 per would be appropriate for OCONS theater port, airfield, railhead, and equipment depot. In CONUS, 2-5 units would be appropriate for the CTC’s, maintenance depots, rail heads, APODS and SPODS; 2 at with heavy division, brigade and FCB Garrison and training location.”

“In a sustainable version of the current exploratory, but “heavy”, demonstration configuration, the system would be practical for locations such as logistics bases, ports, airfields, maintenance depots, etc. where time, security and large numbers of vehicles and material are located/brought and must be washed down/decontaminated. This would be very appropriate for washdown of deployed vehicles at docks and airfields prior to loading to the United States.”