

The public reporting burden for this collection of information is estimated to average 1 hour per response, including the time for reviewing instructions, searching existing data sources, gathering and maintaining the data needed, and completing and reviewing the collection of information. Send comments regarding this burden estimate or any other aspect of this collection of information, including suggestions for reducing this burden, to Washington Headquarters Services, Directorate for Information Operations and Reports, 1215 Jefferson Davis Highway, Suite 1204, Arlington VA, 22202-4302. Respondents should be aware that notwithstanding any other provision of law, no person shall be subject to any penalty for failing to comply with a collection of information if it does not display a currently valid OMB control number.
PLEASE DO NOT RETURN YOUR FORM TO THE ABOVE ADDRESS.

1. REPORT DATE (DD-MM-YYYY) 30-06-2014	2. REPORT TYPE Final Report	3. DATES COVERED (From - To) 1-Sep-2010 - 31-Mar-2014
---	--------------------------------	--

4. TITLE AND SUBTITLE Quantum Illumination-based Target Detection and Discrimination	5a. CONTRACT NUMBER W911NF-10-1-0430
	5b. GRANT NUMBER
	5c. PROGRAM ELEMENT NUMBER 611102

6. AUTHORS Jeffrey H. Shapiro, Franco N. C. Wong	5d. PROJECT NUMBER
	5e. TASK NUMBER
	5f. WORK UNIT NUMBER

7. PERFORMING ORGANIZATION NAMES AND ADDRESSES Massachusetts Institute of Technology (MIT) 77 Massachusetts Ave. NE18-901 Cambridge, MA 02139 -4307	8. PERFORMING ORGANIZATION REPORT NUMBER
---	--

9. SPONSORING/MONITORING AGENCY NAME(S) AND ADDRESS (ES) U.S. Army Research Office P.O. Box 12211 Research Triangle Park, NC 27709-2211	10. SPONSOR/MONITOR'S ACRONYM(S) ARO
	11. SPONSOR/MONITOR'S REPORT NUMBER(S) 58168-PH-OC.3

12. DISTRIBUTION AVAILABILITY STATEMENT Approved for Public Release; Distribution Unlimited
--

13. SUPPLEMENTARY NOTES The views, opinions and/or findings contained in this report are those of the author(s) and should not be construed as an official Department of the Army position, policy or decision, unless so designated by other documentation.

14. ABSTRACT The main thrust of our program was proof-of-principle quantum illumination (QI) experiments to demonstrate QI's target detection capabilities. Supporting theoretical work to advance understanding and enhancement of the QI paradigm was also included. Our experiments demonstrated high signal-to-noise ratio (SNR) quantum-illumination target detection in a lossy, noisy environment using an optical parametric amplifier (OPA) receiver, and explored the SNR's dependence on key parameters such as the signal attenuation, the noise level, and the OPA gain. We constructed a classical (lossy) illumination system which used homodyne reception instead of an OPA and

15. SUBJECT TERMS quantum communication, target detection, entanglement, parametric downconversion, optical parametric amplifiers
--

16. SECURITY CLASSIFICATION OF:			17. LIMITATION OF ABSTRACT UU	15. NUMBER OF PAGES	19a. NAME OF RESPONSIBLE PERSON Jeffrey Shapiro
a. REPORT UU	b. ABSTRACT UU	c. THIS PAGE UU			19b. TELEPHONE NUMBER 617-253-4179

Report Title

Quantum Illumination-based Target Detection and Discrimination

ABSTRACT

The main thrust of our program was proof-of-principle quantum illumination (QI) experiments to demonstrate QI's target detection capabilities. Supporting theoretical work to advance understanding and enhancement of the QI paradigm was also included. Our experiments demonstrated high signal-to-noise ratio (SNR) quantum-illumination target detection in a lossy, noisy environment using an optical parametric amplifier (OPA) receiver, and explored the SNR's dependence on key parameters such as the signal attenuation, the noise level, and the OPA gain. We constructed a classical (laser) illumination system, which used homodyne reception instead of an OPA, and compared its SNR to the QI system's. Our theoretical work studied the use of dual-OPA reception as a route to account for random phase in the target return. It showed that such an approach is infeasible, thus indicating the need to do active phase-tracking in QI target detection. We also found that the single-OPA receiver still provides a QI target-detection performance advantage, in comparison to a laser system of the same average transmitted photon number, when the target return has random-amplitude behavior. Receiver operating characteristic comparison between QI and an erbium-doped fiber amplifier source showed that quantum illumination provides more than 27 dB of stealth advantage in target detection.

Enter List of papers submitted or published that acknowledge ARO support from the start of the project to the date of this printing. List the papers, including journal references, in the following categories:

(a) Papers published in peer-reviewed journals (N/A for none)

<u>Received</u>	<u>Paper</u>
-----------------	--------------

TOTAL:

Number of Papers published in peer-reviewed journals:

(b) Papers published in non-peer-reviewed journals (N/A for none)

<u>Received</u>	<u>Paper</u>
-----------------	--------------

TOTAL:

Number of Papers published in non peer-reviewed journals:

(c) Presentations

Number of Presentations: 0.00

Non Peer-Reviewed Conference Proceeding publications (other than abstracts):

Received Paper

TOTAL:

Number of Non Peer-Reviewed Conference Proceeding publications (other than abstracts):

Peer-Reviewed Conference Proceeding publications (other than abstracts):

Received Paper

10/09/2013 2.00 Sara Mouradian, Franco N. C. Wong, Jeffrey H. Shapiro. Improved Target-Detection Signal-to-Noise Ratio via Quantum Illumination, CLEO 2013. 09-JUN-13, . . . ,

TOTAL: 1

Number of Peer-Reviewed Conference Proceeding publications (other than abstracts):

(d) Manuscripts

Received Paper

TOTAL:

Number of Manuscripts:

Books

Received Book

TOTAL:

Received Book Chapter

TOTAL:

Patents Submitted

Patents Awarded

Awards

Dr. Franco N.C. Wong was elected a Fellow of the Optical Society of America (OSA) in 2014 for pioneering development and applications of spontaneous parametric downconverter sources of entangled light, including the Sagnac source, single-photon two-qubit quantum logic, and secure communication using quantum illumination.

Professor Jeffrey H. Shapiro was elected a Fellow of SPIE for achievements in quantum optical communication, the role of turbulence and random media, and laser radar.

Professor Jeffrey H. Shapiro was co-recipient of MIT Lincoln Laboratory's 2013 Best Paper Award for J.H. Shapiro and A. L. Puryear, "Reciprocity-enhanced optical communication through atmospheric turbulence -- Part I: Reciprocity proofs and far-field power transfer optimization," J. Opt. Commun. Netw. 4, 947-954 (2012) and A.L. Puryear, J.H. Shapiro, and R.R. Parenti, "Reciprocity-enhanced optical communication through atmospheric turbulence -- Part II: Communication architectures and performance," J. Opt. Commun. Netw. 5, 888-900 (2013).

Graduate Students

<u>NAME</u>	<u>PERCENT SUPPORTED</u>
FTE Equivalent:	
Total Number:	

Names of Post Doctorates

<u>NAME</u>	<u>PERCENT SUPPORTED</u>
P. Ben Dixon	0.31
FTE Equivalent:	0.31
Total Number:	1

Names of Faculty Supported

<u>NAME</u>	<u>PERCENT SUPPORTED</u>	National Academy Member
Jeffrey H. Shapiro	0.02	
FTE Equivalent:	0.02	
Total Number:	1	

Names of Under Graduate students supported

<u>NAME</u>	<u>PERCENT SUPPORTED</u>
FTE Equivalent:	
Total Number:	

Student Metrics

This section only applies to graduating undergraduates supported by this agreement in this reporting period

The number of undergraduates funded by this agreement who graduated during this period: 0.00

The number of undergraduates funded by this agreement who graduated during this period with a degree in science, mathematics, engineering, or technology fields:..... 0.00

The number of undergraduates funded by your agreement who graduated during this period and will continue to pursue a graduate or Ph.D. degree in science, mathematics, engineering, or technology fields:..... 0.00

Number of graduating undergraduates who achieved a 3.5 GPA to 4.0 (4.0 max scale):..... 0.00

Number of graduating undergraduates funded by a DoD funded Center of Excellence grant for Education, Research and Engineering:..... 0.00

The number of undergraduates funded by your agreement who graduated during this period and intend to work for the Department of Defense 0.00

The number of undergraduates funded by your agreement who graduated during this period and will receive scholarships or fellowships for further studies in science, mathematics, engineering or technology fields:..... 0.00

Names of Personnel receiving masters degrees

<u>NAME</u>
Total Number:

Names of personnel receiving PHDs

<u>NAME</u>
Total Number:

Names of other research staff

<u>NAME</u>	<u>PERCENT SUPPORTED</u>
Franco N. C. Wong	0.12
FTE Equivalent:	0.12
Total Number:	1

Sub Contractors (DD882)

Inventions (DD882)

Scientific Progress

See attachment

Technology Transfer

Quantum Illumination-Based Target Detection and Discrimination

June 30, 2014

Research Summary

The main thrust of our program was to perform proof-of-principle quantum illumination (QI) experiments for improved target detection. In addition, supporting theoretical work to advance understanding and enhancement of the QI paradigm was included in our program.

Experimental Work

Quantum illumination (QI) is a novel technique [1, 2] for achieving an advantage over classical-state illumination in target detection in a high loss and high noise environment. The focus of our QI experimental efforts was a proof-of-concept demonstration of QI target detection and compare the results to those of a classical illumination setup. Below we summarize our work in the implementation and results of the tabletop experiment.

The QI experimental configuration we employed is shown schematically in Fig. 1. Multi-temporal-mode entangled signal and idler beams were generated by spontaneous parametric downconversion (SPDC) in a 4-cm-long periodically poled magnesium oxide-doped lithium niobate (MgO:PPLN) crystal. PPLN is highly nonlinear and its copolarized frequency-nondegenerate outputs at the signal and idler wavelengths of 1590 nm and 1530 nm, respectively, were easily separated with a long-pass edge filter (Semrock) that reflected nearly 100% of the idler light. The pump was loosely focused at the MgO:PPLN crystal and the signal and idler outputs were optimally coupled into their respective single-mode fibers. The pump focusing and collection optics were designed to maximize the heralding efficiency of the idler light [3], as needed for maximizing the signal-to-noise ratio in QI target detection. Using gated InGaAs avalanche photodiodes as single-photon detectors, we measured a single-mode conditional coupling efficiency of $\sim 93\%$ of an idler photon upon the detection of a signal photon.

A coarse wavelength-division multiplexer (CWDM) filter with a 16 nm bandwidth that is centered at 1590 nm was used to define the bandwidth of the signal output. The signal photon number per mode N_S was much less than unity and the number of temporal modes contained within the 16-nm (~ 2 THz) bandwidth of the CWDM filter was estimated to be about 4×10^{12} per second. We applied phase modulation to the signal beam with a square-wave π -phase modulation depth in the kHz range for clean detection in an audio spectral

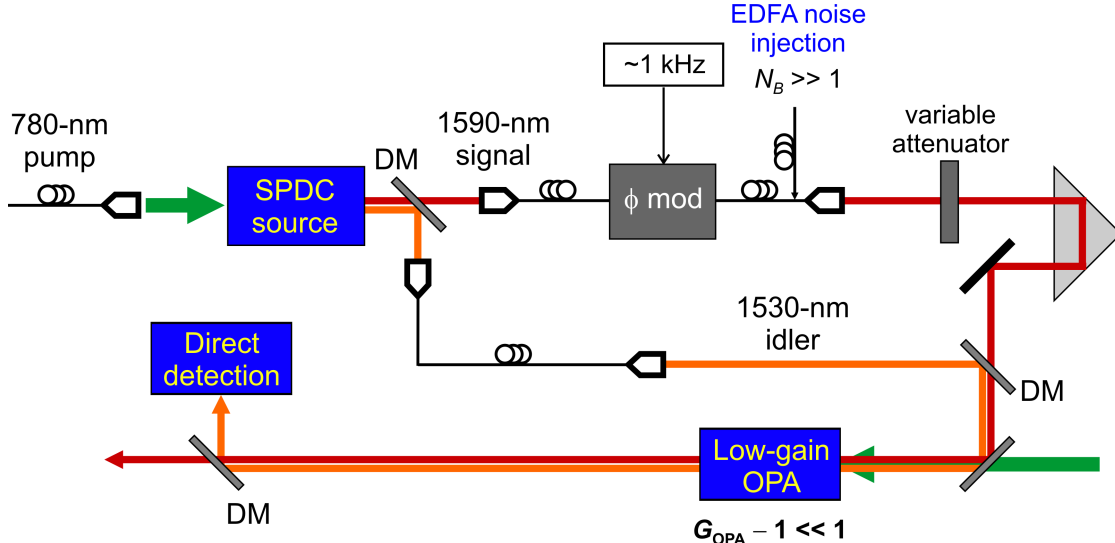

Figure 1: Schematic of experimental setup for QI-based target detection under high-loss and high-noise conditions. Phase modulation in the kHz range is imposed on the signal to allow easy signal recovery using an audio spectrum analyzer.

region that is free of significant technical noise. The signal was attenuated with a free-space variable attenuator to simulate the loss expected in a target detection scenario. Broadband amplified emission noise from an erbium-doped fiber amplifier (EDFA) was combined with the signal to simulate a high-noise environment, with a noise photon number per mode N_B in the range 40–300. The returned signal with injected noise was then combined with the cw pump and the retained idler beam for phase-sensitive detection using a low-gain optical parametric amplifier (OPA) as the joint quantum receiver [4]. The OPA output at the idler wavelength was directly detected using an InGaAs p-i-n photodiode with an estimated quantum efficiency of 85% and an ultralow-noise transimpedance amplifier. Compared with to our initial QI measurements, which used an InGaAs avalanche photodiode, the p-i-n photodiode yielded a better signal-to-noise ratio (SNR) because it does not have the excess noise associated with the avalanche multiplication process. The observed signal was then measured using an audio network analyzer. Figure 2 shows the measured results for a modulation frequency of 20 kHz without or with the target’s presence, i.e., by blocking or unblocking the signal beam path. The high SNR in Fig. 2 shows that a much wider measurement bandwidth (shorter integration interval) could be used.

Theory indicates that quantum illumination with the OPA receiver should perform better than a classical illumination setup with the same output signal power by a factor of two in the SNR [4] under ideal operating conditions with ideal components. We set up a classical illumination experiment to compare with the QI measurements. Figure 3 shows the setup for classical illumination. A 1550-nm laser was used to generate the signal for interrogating the target and the local oscillator used in the homodyne receiver. For a proper comparison with the QI measurements, our classical source used the same amount of signal power as the total signal power used in QI.

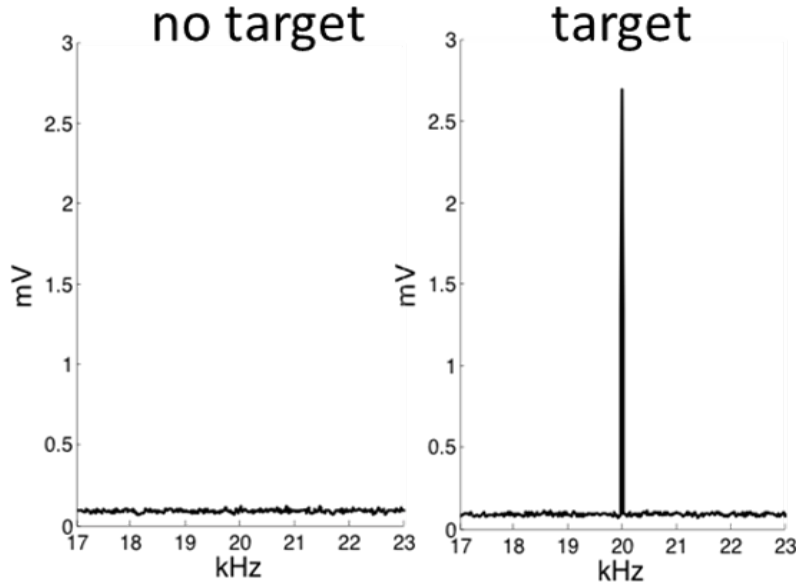

Figure 2: Received signal output obtained from an audio spectrum analyzer without or with the target. Signal loss is ~ 13 dB and injected noise is 2×10^4 higher than signal strength.

Figure 4 shows the target detection SNR comparison between classical illumination and earlier QI measurements that were made with the InGaAs avalanche photodiode. The lower set of data (black) is for a signal photon number N_S of 2×10^{-5} per mode, and the upper set of data (blue) is for a higher pump power that yields 2×10^{-4} photon per mode. Other operating conditions are the same for both cases: 300 noise photons per mode and signal transmission of 0.02. The measured SNR for QI as a function of the OPA receiver gain ($G - 1$) setting shows that the SNRs are not a sharp function of the gain; however, there is an optimal gain setting to maximize the SNR that is clearly evident in both N_S cases. Note that the difference between the two QI measured values of ~ 10 dB is the same as the difference in their N_S values. The classical illumination measurements show higher SNRs than the QI measurements by ~ 3 dB. In comparison, theory expects the ideal case for QI should yield 3 dB higher SNR than the classical measurements, as indicated by the dashed curves in Fig. 4. The discrepancy between the ideal case and the measured values for QI is due to nonideal components and operating conditions, such as transmission efficiency in the retained idler channel of 0.8, sub-unity detector quantum efficiency of 0.73, and sub-unity pairing of the signal and idler modes of 0.44 [5]. The dotted curves in Fig. 4 represent the expected QI values if we make realistic improvements to these efficiencies, in which case an improvement of between 1 to 2 dB over the classical case is possible.

The final experimental setup for QI target detection is shown in Fig. 1. To achieve high heralding efficiency, we implemented two zoom-lens systems to optimize the confocal parameters for the signal and idler beams produced by SPDC. We fixed the pump-beam focal size at the SPDC and maximized the heralding efficiency by choosing different zoom-lens settings. A heralding efficiency of 83% was measured using InGaAs APDs. The heralding efficiency could be further increased by improving the filters between the SPDC output and the idler

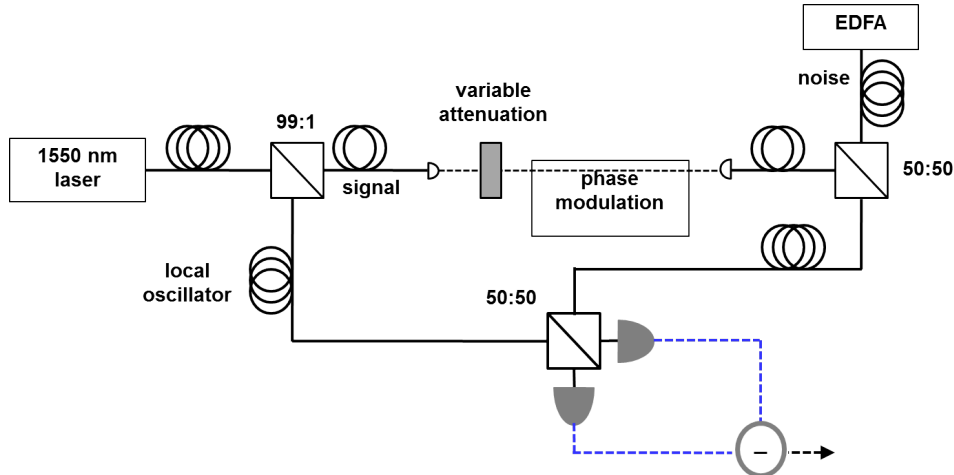

Figure 3: Schematic of classical-illumination target detection.

collimator such that the idler loss is reduced. We also improved the idler storage efficiency to 90%, accounting for all losses introduced by fiber connections, propagation, dichroic mirrors, and scattering inside the OPA. We are still working to complete measurements that we believe should demonstrate a 1 to 2 dB SNR advantage for quantum illumination over its classical counterpart.

In summary, we have achieved the following in our experimental efforts in the program:

- Performed extensive tabletop target detection measurements using quantum illumination and classical illumination;
- Showed good agreement with theory;
- Evaluated performance limitations and designed configuration to achieve QI measurement improvement over classical illumination;
- Presented a contributed talk on this work at the CLEO conference in San Jose, June 10–14, 2013.

Theoretical Work

The initial theoretical demonstration that quantum illumination could provide improved performance in target detection relied on a probability-of-error performance metric in which target absence and target presence were equally likely hypotheses [2]. Radar target detection, however, seldom if ever confronts target detection with equal likelihood of target absence or presence. Instead, the Neyman-Pearson criterion is employed, wherein the probability of detection, $P_D \equiv \Pr(\text{decide target present} \mid \text{target present})$, is maximized subject to a constraint on the false-alarm probability, $P_F \equiv \Pr(\text{decide target present} \mid \text{target absent})$. The advantage of using the minimum error-probability criterion—insofar as quantum illumination performance analysis is concerned—is the availability of the quantum Chernoff bound to circumvent the formidable difficulty of evaluating the eigenvalues of a high-dimensional

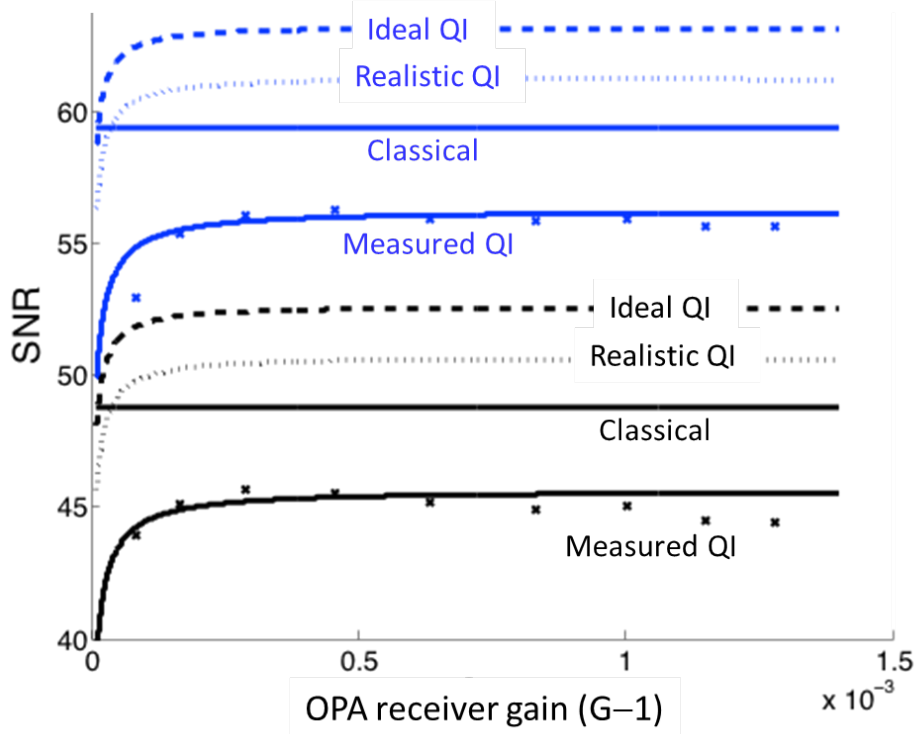

Figure 4: Measured SNRs for QI target detection (filled squares) and classical illumination (solid curves labeled classical) as a function of the OPA receiver gain at two different signal photon numbers per mode, $N_S = 2 \times 10^{-5}$ (black) and 2×10^{-4} (blue). Also shown are the corresponding calculated values for QI under ideal conditions (dashed curve) and more realistic conditions with a number of efficiency improvements (dotted curves).

mixed-state quantum system. In classical detection theory, there are Chernoff-bound formulas that can be applied to P_D versus P_F behavior—what is known as the receiver operating characteristic (ROC)—for target detection. No such bounds are available in the literature for quantum detection, and our work makes it clear that such bounds may not be obtainable. So, to demonstrate that the QI performance advantage in target detection extends to a broad swath of the ROC curve, we compared the P_D versus P_F performance of the optical parametric amplifier (OPA) receiver [4] for quantum illumination with that of the homodyne receiver for coherent-state illumination. Figure 5 shows our results for $\kappa = 0.01$ roundtrip propagation loss when the target is present, $N_S = 0.01$ source brightness, $M = 10^{5.5}$ mode pairs, and $N_B = 20$ background-noise brightness. The OPA receiver’s performance was obtained from the Gaussian approximation (Central Limit Theorem) approximation for that receiver’s photocount statistics, and the homodyne receiver performance is an excellent approximation, in this operating regime, for the performance of the optimum receiver for coherent-state illumination. This figure shows that the QI advantage is retained over the entire ROC range we have examined.

The preceding QI performance evaluations presumed perfect interferometric phase stability and non-fluctuating targets. Because coherent-state target detection with conventional

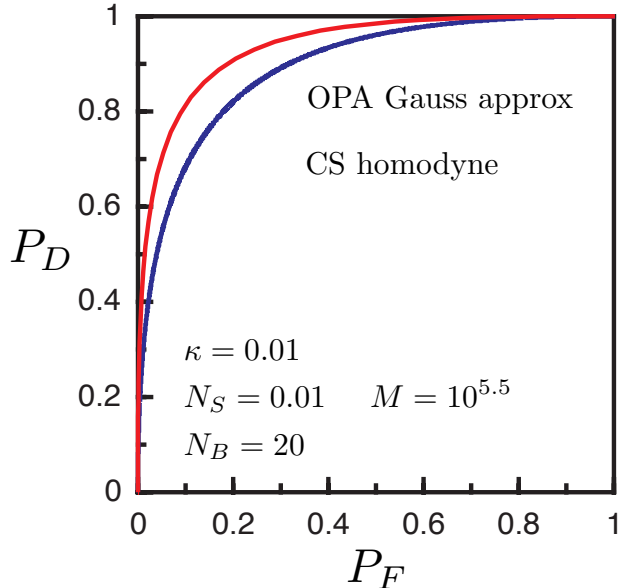

Figure 5: Receiver operating characteristic comparison between OPA reception of a quantum-illumination source and homodyne reception of coherent-state illumination.

coherent-detection receivers reduces to the well-studied problem of detecting a signal in the presence of additive white Gaussian noise, many results are available in this case for target-detection performance in the presence of random target phase or amplitude behavior, but no such results had been developed for QI operation prior to our work in which we investigated QI receivers capable of accommodating uniformly-distributed random phase or fluctuating target amplitude. Unfortunately, the results we obtained offered very limited encouragement [6]. In particular, we did not find a QI receiver that outperforms the OPA receiver when there is neither random phase nor random amplitude. Moreover, the dual-OPA receiver—which does 50–50 beam splitting of the return light and the idler light and then performs OPA reception on each of the resulting output beams with one OPA tuned to amplify the real quadrature and the other tuned to amplify the imaginary quadrature—does *not* yield acceptable error probability, as we had initially hoped. Indeed, its performance is far worse than the dual-homodyne (or heterodyne) receiver that can be used for coherent-state operation. On the other hand, with stable phase we have found that QI operation with OPA reception continues to outperform coherent-state operation with homodyne detection when the target has random amplitude behavior with either Rayleigh or exponential statistics. However, because target randomness can be expected to exhibit itself in *both* phase *and* amplitude, multiple-pulse QI operation with phase tracking will likely be required for such scenarios.

All of the work described above presumed that the target-detection performance comparison should be made between a coherent-state (classical) system and the quantum-illumination system. Barring discovery of a way to realize optimum quantum reception for QI, the maximum error-exponent (SNR) advantage for QI over its classical competitor is

the 3 dB afforded by OPA reception. Moreover, that is only possible under ideal operating conditions with ideal components. Indeed, our experiments confirm that realizing that full 3 dB advantage is quite challenging. There is, however, another comparison that places QI in a much more favorable light: target detection with stealth. The high brightness of a laser illuminator whose power matches that of a QI transmitter makes it readily detectable at the target. Consider, instead, using an erbium-doped fiber amplifier (EDFA) as the transmitter, whose bandwidth matched that of the QI transmitter. At the same brightness, both would be equally and much more stealthy than the laser transmitter. As shown in Fig. 6, however, the QI system has a vastly superior receiver operating characteristic in comparison with the EDFA system, with latter requiring more than 27 dB higher brightness to approach the former’s P_D versus P_F behavior. Here, QI’s enormous performance advantage is similar to what is present in a communication context, when QI has been shown, theoretically, to provide immunity to passive eavesdropping under ideal operating conditions with ideal components [7]. More importantly, recent experimental work has shown that this immunity can be realized under realistic operating conditions with realistic components [8], so stealthy QI-based target detection should definitely be possible.

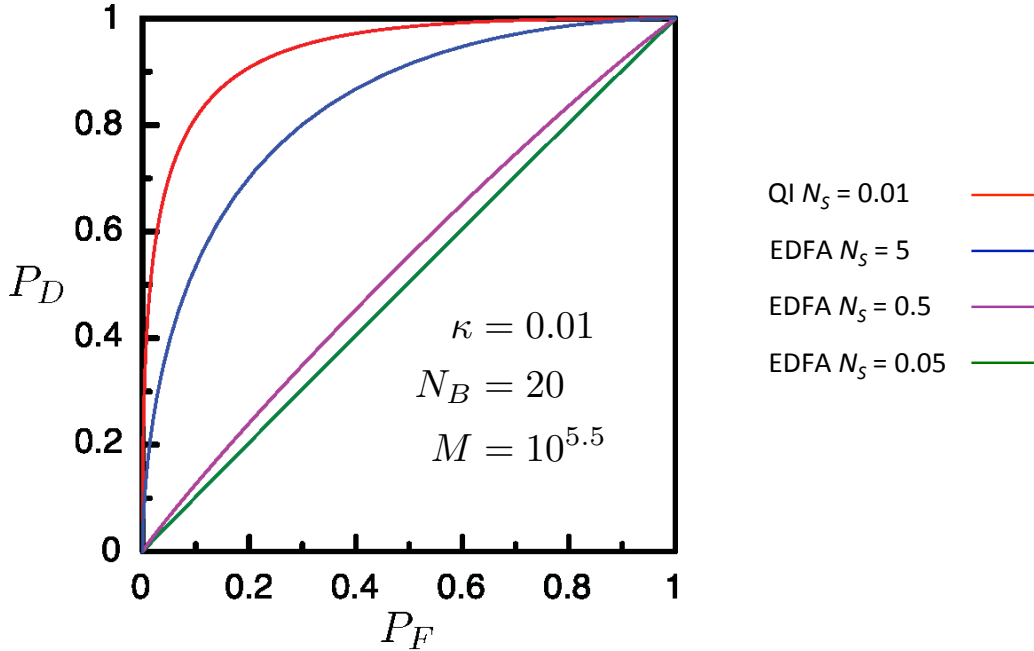

Figure 6: Receiver operating characteristic comparison between OPA reception of a quantum-illumination source and direct-detection of an EDFA source of the same bandwidth. N_S = source brightness (photons/mode); κ = roundtrip transmissivity; N_B = background brightness; and M = number temporal modes (EDFA) or mode pairs (QI).

References

- [1] S. Lloyd, “Enhanced sensitivity of photodetection via quantum illumination,” *Science* **321**, 1463 (2008).
- [2] S.-H. Tan, B. I. Erkmen, V. Giovannetti, S. Guha, S. Lloyd, L. Maccone, S. Pirandola, and J. H. Shapiro, “Quantum illumination with Gaussian states,” *Phys. Rev. Lett.* **101**, 253601 (2008).
- [3] R. S. Bennink, “Optimal collinear Gaussian beams for spontaneous parametric down-conversion,” *Phys. Rev. A* **81**, 053805 (2010).
- [4] S. Guha and B. I. Erkmen, “Gaussian-state quantum illumination receivers for target detection,” *Phys. Rev. A* **80**, 052310 (2009).
- [5] S. Mouradian, “Target detection through quantum illumination,” M.Eng. thesis, Dept. of Elect. Eng. and Comput. Sci., MIT, Feb. 2012.
- [6] C. D. Samolis, “Gaussian quantum illumination under random amplitude and phase,” 6.UAP Final Report, Dept. of Elect. Eng. and Comput. Sci., MIT, May 2012.
- [7] J. H. Shapiro, “Defeating passive eavesdropping with quantum illumination,” *Phys. Rev. A* **80**, 022320 (2009).
- [8] Z. Zhang, M. Tengner, T. Zhong, F. N. C. Wong, and J. H. Shapiro, “Entanglement’s benefit survives an entanglement-breaking channel,” *Phys. Rev. Lett.* **111**, 010501 (2013).