

STABILITY IN THE OFFENSE: THE EVOLUTION OF CIVIL AFFAIRS DURING WORLD WAR II

A Monograph

by

MAJ Scott C. Sinclair
United States Army



School of Advanced Military Studies
United States Army Command and General Staff College
Fort Leavenworth, Kansas

2014-01

REPORT DOCUMENTATION PAGE

Form Approved
OMB No. 0704-0188

Public reporting burden for this collection of information is estimated to average 1 hour per response, including the time for reviewing instructions, searching existing data sources, gathering and maintaining the data needed, and completing and reviewing this collection of information. Send comments regarding this burden estimate or any other aspect of this collection of information, including suggestions for reducing this burden to Department of Defense, Washington Headquarters Services, Directorate for Information Operations and Reports (0704-0188), 1215 Jefferson Davis Highway, Suite 1204, Arlington, VA 22202-4302. Respondents should be aware that notwithstanding any other provision of law, no person shall be subject to any penalty for failing to comply with a collection of information if it does not display a currently valid OMB control number. **PLEASE DO NOT RETURN YOUR FORM TO THE ABOVE ADDRESS.**

1. REPORT DATE (DD-MM-YYYY) 22 MAY 2014		2. REPORT TYPE Master's Thesis		3. DATES COVERED (From - To) JUN 2013-MAY 2014	
4. TITLE AND SUBTITLE STABILITY IN THE OFFENSE: THE EVOLUTION OF CIVIL AFFAIRS DURING WORLD WAR II				5a. CONTRACT NUMBER	
				5b. GRANT NUMBER	
				5c. PROGRAM ELEMENT NUMBER	
6. AUTHOR(S) Major Scott C Sinclair, U.S. Army				5d. PROJECT NUMBER	
				5e. TASK NUMBER	
				5f. WORK UNIT NUMBER	
7. PERFORMING ORGANIZATION NAME(S) AND ADDRESS(ES) School of Advanced Military Studies 250 Gibbon Ave. Ft. Leavenworth, KS 66027				8. PERFORMING ORGANIZATION REPORT NUMBER	
9. SPONSORING / MONITORING AGENCY NAME(S) AND ADDRESS(ES) U.S. Army Command and General Staff College ATTN: ATZL-SWD-GD Fort Leavenworth, KS 66027-2301				10. SPONSOR/MONITOR'S ACRONYM(S)	
				11. SPONSOR/MONITOR'S REPORT NUMBER(S)	
12. DISTRIBUTION / AVAILABILITY STATEMENT Approved for Public Release; Distribution Unlimited					
13. SUPPLEMENTARY NOTES					
14. ABSTRACT <p>Transitional failures in Iraq and Afghanistan created a fundamental shift in how the Army views its war-fighting role. As a result, the Army created the concept of Unified Land Operations. Army Doctrinal Publication 3-0: <i>Unified Land Operations</i> (ULO) calls for the "...continuous, simultaneous combinations of offensive, defensive, and stability...." Using a chronologic presentation of the conduct of civil affairs and military government operations in the European Theater during World War II, this monograph tests the concept of stability operations executed during offensive operations.</p> <p>My hypothesis is that the Allies' experience in World War II provides evidence that, when planned and resourced appropriately, stability and offensive operations can be conducted continuously and simultaneously, setting the conditions for a military and political victory. This monograph uses a number of sources to include official operation reports from the 12th Army and the Army's official histories discussing civil affairs and the occupation of Germany.</p> <p>This monograph concludes that the methods and lessons learned by Allied leaders when employing civil affairs forces with combat forces during World War II have application to today's war-fighter. Gaps exist in ULO in that it describes the interagency as the organization responsible for stability and fails to specifically identify the military's role in stability beyond security. In operations that require an interim government ULO does not address the necessity to create a separate stability force that is operationally and logistically capable, and integrated with combat forces prior to the commencement of operations. Failure to do so is a return to the pre-World War II ad hoc nature of stability operations and increases risk to mission success.</p>					
15. SUBJECT TERMS					
16. SECURITY CLASSIFICATION OF:			17. LIMITATION OF ABSTRACT	18. NUMBER OF PAGES	19a. NAME OF RESPONSIBLE PERSON
a. REPORT	b. ABSTRACT	c. THIS PAGE			19b. TELEPHONE NUMBER (include area code)
(U)	(U)	(U)	(U)	53	

MONOGRAPH APPROVAL PAGE

Name of Candidate: MAJ Scott C. Sinclair

Monograph Title: Stability in the Offense: The Evolution of Civil Affairs During World War II

Approved by:

_____, Monograph Director
G. Stephen Lauer, Ph.D.

_____, Seminar Leader
Uwe Jansohn, COL

_____, Director, School of Advanced Military Studies
Henry A. Arnold III, COL

Accepted this 22nd day of May by:

_____, Director, Graduate Degree Programs
Robert F. Baumann, Ph.D.

The opinions and conclusions expressed herein are those of the student author and do not necessarily represent the views of the US Army Command and General Staff College or any other governmental agency. (References to this study should include the foregoing statement.)

ABSTRACT

STABILITY IN THE OFFENSE: THE EVOLUTION OF CIVIL AFFAIRS DURING WORLD WAR II,
by MAJ Scott C. Sinclair, 57 pages.

Transitional failures in Iraq and Afghanistan created a fundamental shift in how the Army views its war-fighting role. As a result, the Army created the concept of Unified Land Operations. Army Doctrinal Publication 3-0: *Unified Land Operations* (ULO) calls for the "...continuous, simultaneous combinations of offensive, defensive, and stability...." Using a chronologic presentation of the conduct of civil affairs and military government operations in the European Theater during World War II, this monograph tests the concept of stability operations executed during offensive operations.

My hypothesis is that the Allies' experience in World War II provides evidence that, when planned and resourced appropriately, stability and offensive operations can be conducted continuously and simultaneously, setting the conditions for a military and political victory. This monograph uses a number of sources to include official operation reports from the 12th Army and the Army's official histories discussing civil affairs and the occupation of Germany.

This monograph concludes that the methods and lessons learned by Allied leaders when employing civil affairs forces with combat forces during World War II have application to today's war-fighter. Gaps exist in ULO in that it describes the interagency as the organization responsible for stability and fails to specifically identify the military's role in stability beyond security. In operations that require an interim government ULO does not address the necessity to create a separate stability force that is operationally and logistically capable, and integrated with combat forces prior to the commencement of operations. Failure to do so is a return to the pre-World War II ad hoc nature of stability operations and increases risk to mission success.

ACKNOWLEDGEMENTS

I would like to thank the following; my family for their patients and understanding. Mr. Stephen Melton for paving the way for my research into the history of civil affairs in World War II. Dr. Kevin Benson for taking the time to educate me on recent history; it was professionally and personally enlightening. Colonel Uwe Jansohn for keeping my feet to the fire. And finally, Estee Pinchasin for taking the time out of her busy schedule to help me temper my verbose writing style.

TABLE OF CONTENTS

	Page
TABLE OF CONTENTS.....	v
ACRONYMS.....	vi
TABLES.....	vii
INTRODUCTION.....	1
SECTION 1: STABILITY IN WAR.....	6
Doctrine.....	7
The History.....	10
SECTION 2: THE AFRICAN THEATER: WHO SHOULD BE IN CHARGE OF OCCUPATION? 16	
Africa: The Fight for Military Control of Civil Affairs.....	16
SECTION 3: SICILY AND ITALY: THE TESTING GROUND FOR CIVIL AFFAIRS.....	19
Organization.....	20
The US's Civil Affairs Division.....	20
Military Government Planning in the African Headquarters (AFHQ).....	21
Organization: Allied Military Government of Occupied Territory.....	23
Command and Control.....	25
Execution.....	27
SECTION 4: THE EUROPEAN THEATER.....	28
Organization.....	29
Lessons Learned from Italy.....	32
Return of the AMGOT?.....	35
Organization below SHAEF.....	38
Planning.....	40
Execution.....	43
Lessons Learned.....	45
CONCLUSION.....	47
Recommendations.....	49
BIBLIOGRAPHY.....	51
Primary Sources.....	51

ACRONYMS

ADP	Army Doctrinal Publication
ADRP	Army Doctrinal Reference Publication
AFHQ	Africa Headquarter
AMGOT	Allied Military Government of Occupied Territory
CAD	Civil Affairs Division
CAM	Combined Arms Manuever
COSSAC	Chief of Staff to the Supreme Allied Commander
DARTS	Disaster Assistance Response Teams
DOS	Department of State
ETO	European Theater of Operation
ETOUSA	European Theater United States Army
FACT	Field Advance Civilian Teams
FM	Field Manual
FUSAG	First United States Army Group
GO	General Orders
ICU	Information Control Unit
JCS	Joint Chiefs of Staff
PRT	Provincial Reconstruction Team
SHAEF	Supreme Headquarters Allied Expeditionary Force
ULO	Unified Land Operations
UN	United Nations
USAID	United States Agency for International Development
WAS	Wide Area Securiry

TABLES

	Page
Table 1. US Military Government Relationships (Mobile Phase, Sept 1944-Jul 1945).....	38

INTRODUCTION

I was stunned by what I saw as amazing bungling after the initial military success, including failing to stop looting of Baghdad, disbanding the Iraqi army, and implementing a draconian de-Baathification policy that seemed to ignore every lesson from the post-1945 de-Nazification of Germany.

—Robert Gates, *Duty*

On December 5th, 2006, three years after the United States and its coalition partners invaded Iraq; members of Congress met for the confirmation hearing of Dr. Robert Gates, President Bush's nominee for Secretary of Defense. The wars in Iraq and Afghanistan were seen to be going poorly and they represented the President's frustrated attempt to "shift the use of the military away from the numerous humanitarian and peacekeeping interventions of the 1990s."¹ During the hearing Senator Carl Levin voiced a popular criticism regarding the preparation and execution of the invasion of Iraq. In his opening remarks he stated, "Before the invasion of Iraq, we failed to plan to provide an adequate force for the occupation of the country, or to plan for the aftermath of major combat operations."²

Senator Levin's comments, while echoing the general narrative of the time, may not be accurate. In his article, *Blind into Baghdad*, James Fallows provides a different explanation. He believes that "the U.S. occupation of Iraq was a debacle not because the government did no planning but because a vast amount of expert planning was willfully ignored by the people in charge."³ Colonel Kevin Benson⁴ also

¹JCOA, *Decade of War, Volume I: Enduring Lessons from the Past Decade of Operations* (Joint and Coalition Operational Analysis, June 15, 2012), 1.

²"Confirmation Hearing of Robert Gates to Be Secretary of Defense," *Washington Post*, 5 December 2006, http://media.washingtonpost.com/wp-srv/politics/documents/rgates_hearing_120506.html (accessed 18 January 2014).

³James Fallows, "Blind Into Baghdad," *The Atlantic* (January 2004), <http://www.theatlantic.com/magazine/archive/2004/01/blind-into-baghdad/302860/> (accessed 19 January 2014).

⁴Colonel (Ret) Kevin Benson served as the Assistant Chief of Staff, C5 (Plans), Combined Forces Land Component Command and Third US Army from June 2002 to July 2003 during Operation IRAQI FREEDOM/Operation COBRA II and Operation ECLIPSE II. Dr. Benson's final posting in the Army was the Director, School of Advanced Military Studies, SAMS. He served in Baghdad as a member of the J5, US Forces-Iraq from October 2010 to January 2011, at the request of the commanding general.

refutes the assertion that the military failed to plan, stating quite clearly that the critics are “wrong in claiming that [the coalition] did not plan for Phase IV.”⁵ Benson asserts that he and his team developed a post conflict plan, code named ECLIPSE II sequel to the invasion plan, COBRA II.⁶

Despite all of the coalition’s preparations and planning, the subsequent protracted conflict was not the desired outcome and clearly something went wrong.⁷ The transitional failures in Iraq and Afghanistan created a shift in how the Army views its war-fighting role. As a result, the Army created the concept of Decisive Action. This new doctrine calls for the “continuous, simultaneous combinations of offensive, defensive, and stability.”⁸

Since its inception, decisive action has only been practically applied as part of counter insurgency operations. As a doctrinal construct, decisive action has yet to be applied to what is commonly referred to as conventional warfare. In prior combat operations, stability operations (Phase IV) were typically planned to be executed upon completion of military objectives, also known as the dominate phase (Phase III).⁹ If stability operations are only conducted following combat operations, how does the construct of simultaneity affect offensive operations such as the invasion of Iraq? Can stability operations be performed simultaneously and integrated with offensive operations and if so, to what extent? The answer to these questions can be found in the United States’ involvement in World War II. During operations in

⁵Kevin C. M. Benson, “OIF Phase IV: A Planner’s Reply to Brigadier Aylwin-Foster,” *Military Review* (March 2006): 61, <http://cgsc.contentdm.oclc.org/utis/getfile/collection/p124201coll1/id/35/filename/36.pdf>. (accessed 8 February 2014).

⁶Military plans are divided into phases, representing sequential sub-operations. A typical phased plan is divided into four phases; deter/engage, seize initiative, decisive operations, transition to post combat/stability operations. The original ECLIPSE plan was the World War II occupation plan of Germany to be executed after Germany capitulated.

⁷Conrad C. Crane and W. Andrew Terrill, *Reconstructing Iraq: Challenges and Mission for Military Forces in Post-Conflict Scenario* (Army War College: Strategic Studies Institute, Army War College Press, 2003), 3.

⁸Headquarters, Department of the Army, Army Doctrine Reference Publication (ADRP) 3-0, *Unified Land Operations* (Washington, DC: Government Printing Office, 2012), 3–0.

⁹Chairman, Joint Chiefs of Staff, Joint Publication (JP) 3-0, *Joint Operations* (Washington, DC: Government Printing Office, 2011), V-6.

Europe, Allied forces deliberately planned and executed combat operations simultaneously with civil affairs operations. In so doing, civil affairs operations enabled, and were de-conflicted with, tactical combat operations, setting the conditions for subsequent operations.

The hypothesis of this monograph is that the Allies' experience in World War II provides evidence that, when planned and resourced appropriately, stability and offensive operations can be conducted continuously and simultaneously, setting the conditions for a military and political victory. This monograph is not a study of counter insurgency, nor is it about war transition. It is a test of the concept of decisive action employed during the decisive phase. The examination of the evolution of civil affairs during World War II provides a contextual backdrop to determine the effectiveness of decisive action in a major offensive campaign. It facilitates an understanding of what decisions were made, and why they were made, as well as a contextual framework that will inform future offensive operations.

The limits of this monograph are operations in the European theater during World War II, primarily at the theater and campaign commander level. In-depth examinations of the decisions made by tactical commanders and specific policy decisions made by civilian political leaders will only be addressed when directly applicable to the case study. The intent is to analyze the feasibility of planning and executing offensive and stability operations simultaneously.

The monograph begins with a discussion on current Army doctrine as it relates to the commander's role in civil affairs, defining key terms including unified land operations, decisive action, wide area security, combined arms maneuver, and unity of effort. It is through the review of these terms that will illustrate the underlap between current doctrine and the Army's historically has experience.

This is followed by a description of the historic context in a chronological presentation to identify what experiences, prior to World War II, caused strategic military leadership to become interested in the institutionalization of civil affairs. The impetus for the notion that civil affairs needed to be planned and executed in concert with combat operations began as early as 1940. Experiences in the Spanish American

war, the Philippines, and World War I, generated surge of interest within the War Department to study military governance and ultimately establish an internal capacity to perform such operations.¹⁰

Despite the War Department's interest and practical reasons for preparing to perform an instrumental role in what was to be called civil affairs, an ideological-based counterargument existed. Because of what transpired in the North African theater, the president made the decision to give the military ultimate control over both combat and civil affairs activities. To explore the contention between ideology and practicality, the author analyzes the employment of civil affairs operations in North Africa.

This leads to the analysis of the military's employment of civil affairs units during operations in Sicily, Italy, and finally Germany. This includes the command organization, force structures, tactical employment of civil affairs teams, and the continued political friction military leaders contended with during these operations. Furthermore, the author explores the iterative changes made and how they impacted the final planning of the invasion of Germany. The monograph concludes by reviewing the tenets of decisive action and their employment during the invasion of Germany, demonstrating the validity for stability to be executed both continuously and simultaneously during offensive operations. Finally, it provides recommendations for future operations.

Primary source records and the official histories that pertain to the creation and execution of civil affairs during World War II provide the structural backbone of this monograph. Official histories include Harry L. Cole and Albert K. Weinberg's *Civil Affairs: Soldiers Become Governors*, which provides an extensive record of the creation of civil affairs and its implementation from 1941 to just prior to the invasion of Germany. Earl Ziemke's official history titled *U.S. Army in the Occupation of Germany, 1944-1946*, supplements Cole and Weinberg and describes the military's experiences into the occupation.

The Army initiated two studies that comprehensively examine its experiences in civil affairs. Marshall Andrews and William E. Daugherty's, *A Review of US Historical Experience with Civil Affairs:*

¹⁰Harry L. Coles and Albert K. Weinberg, *Civil Affairs: Soldiers Become Governors*, CMH Pub 11-5 (Washington DC: Center of Military History Department of the Army, 1964), 6.

1776–1954, examines history at the political-strategic level and provides the contextual backdrop for the primary source data. Another study by Stanley Sandler, *Glad to See Them Come and Sorry to See Them Go: A History of U.S. Army Tactical Civil Affairs/Military Government, 1775-1991*, complemented Andrews and Daugherty’s study, by focusing at the tactical level of civil affairs operations.

Other books have been written that examine the military’s experiences in civil affairs during World War II, with the purpose of studying war transition and occupation. Because of their focus, they explain very little on how the military conducted civil affairs during combat operations. They provide insight in their examination of the relationship between military commanders and the civilian policy makers. Several articles, monographs, and journals study various aspects of World War II and their relations to the wars in Afghanistan and Iraq. Each of these pieces examines specific aspects of the civil affairs in World War II, amplifying details of the more comprehensive works already discussed.

“Studying the past is no sure guide to predicting the future. What it does do, though, is to *prepare* you for the future by expanding experience, so that you can increase your skills, your stamina-and, if all goes well, your wisdom.”¹¹ To help in the comparison of current and past doctrine, the monograph addresses the differences in terminology between World War II and today. In 1940, the FM 27-5, *Civil Affairs Military Government* used the terms military government and civil affairs synonymously. It was not until the US entered the war that a need arose to delineate the two.

‘Civil Affairs’ referred to military interaction with the population and government in friendly/liberated territory, such as France. ‘Military Government’ described the commander’s role in hostile or occupied territories.¹² The tasks associated with the two were relatively the same. The main difference was the military’s role in the interactions; the former was seen as a partnership with the

¹¹John Lewis Gaddis, *The Landscape of History: How Historians Map the Past* (Oxford University Press, 2004), 11.

¹²Cristen Oehrig, *Civil Affairs in World War II* (Washington, DC: Center for Strategic and International Studies, January 28, 2009), 2. csis.org/publication/civil-affairs-world-war-ii (accessed 13 August 2013).

liberated nation's government, the latter was a role of domination. In today's doctrine, civil affairs operations pertain specifically to those designated civil affairs forces. 'Civil military operations' is a broader term that describes any civilian and military interaction during operations. The term 'transitional military authority' replaced the term 'military government'.¹³

Compared to today's stability doctrine, the civil affairs doctrine of World War II is sparse. The concepts of stability and civil affairs are more sophisticated today than they were in 1940. Beyond the military's operational role, modern doctrine is more open to interagency collaboration. Despite the differences, a common theme of simultaneous combat and civil affairs operations is present throughout history of stability operations.

This monograph is organized into four sections. Section one discusses current Army doctrine and how it conceptualizes offensive and stability operations. Section one also examines the Army's historical experiences with stability operations during combat. Section two consists of the World War II case study. The focus of section two is the African theater and the decisions that lead to the Army's role in occupation. Section three concentrates on how the Army executed civil affairs and military government operations in the Mediterranean theater. The fifth section discusses civil affairs and military government operations in the European theater, with a focus on how the lessons of the previous two sections shaped operations in Germany.

SECTION 1: STABILITY IN WAR

This section examines current Army doctrine and the role of stability in combat. It then shifts focus to the past where it explores the history of stability in war and how the U.S. Army's experiences affected World War II civil affairs and military government doctrine.

¹³Joint Forces Command, *Handbook for Military Support to Governance, Elections, and Media: Unified Action Handbook Series Book Three*, 2010, ii, http://www.dtic.mil/doctrine/doctrine/jwfc/gem_hbk.pdf, accessed 19 March 2014.

ADP 1 states “doctrine links theory, history, experimentation, and practice...”¹⁴ and that doctrine is the common body of knowledge used to educate and train soldiers and Army civilians.¹⁵ Doctrine “prescribes how personnel and units operate effectively across and outside the Army’s institutional boundaries.”¹⁶ It is the foundation for military leaders and their planners and helps them understand how to organize (both unit organization and command structure), plan, and execute. Doctrine is not all encompassing, signifying the importance in identifying what is absent in doctrine as well.

Doctrine

In 2011, the United States Army unveiled Doctrine 2015, an initiative to reorganize Army doctrine.¹⁷ Army Doctrinal Publication (ADP) 3-0, *Unified Land Operations* (ULO), is one of the first revisions published introduces the Army’s new operational approach, unified land operations,¹⁸ which is the Army’s basic warfighting doctrine that contributes to unified action.¹⁹

¹⁴Department of the Army, Field Manual (FM) 1, *The Army* (Washington, DC: Government Printing Office, 2005), paragraph 1-80, <http://www.army.mil/fm1/chapter1.html#section7>, accessed 19 March 2014..

¹⁵Department of the Army, Army Doctrine Publication (ADP) 1, *The Army*, Change 1 (Washington, DC: Government Printing Office, 2013), 2-4.

¹⁶*Ibid.*

¹⁷The Army has created a hierarchy of manuals, the top of the hierarchy provides broad conceptual descriptions while each subsequent level provides greater detail and technical specificity The naming convention is as follows; Army Doctrinal Publication (ADP), Army Doctrinal Reference Publication (ADRP), Field Manual (FM), and Army Technical Publication (ATP).

¹⁸US Army Doctrine Proponent, “Doctrine Update, 1-12” (Combined Arms Center, 16 December 2011), 4, http://usacac.army.mil/cac2/adp/Repository/Army%20Doctrine%20Update%201-12_16%20Dec%202011.pdf. (accessed 9 February 2014). ADP 3-0 defines unified land operations as how the Army seizes, retains and exploits the initiative to gain and maintain a position of relative advantage in sustained land operations through simultaneous offensive, defensive, and stability operations in order to prevent or deter conflict, prevail in war, and create the conditions for favorable conflict resolution.

¹⁹Chairman, Joint Chiefs of Staff, Joint Publication (JP) 1, *Doctrine for the Army Forces of the United States* (Washington, DC: Government Printing Office, 2013), xiii. “Unified action synchronizes, coordinates, and/or integrates joint, single-Service, and multinational operations with the operations of other USG departments and agencies, nongovernmental organizations (NGOs), intergovernmental organizations (IGOs) (e.g., the United Nations), and the private sector to achieve unity of effort.”

Unified land operations describes the Army's use of decisive action, as the "conduct [of] decisive and sustainable land operations through the simultaneous combination of offensive, defensive, and stability operations...appropriate to the mission and environment."²⁰ Offensive operations are "operations conducted to defeat and destroy enemy forces and seize terrain, resources, and population centers."²¹ Stability operations "are military missions, tasks, and activities conducted outside the United States to maintain or reestablish a safe and secure environment and to provide essential governmental services, emergency infrastructure reconstruction, and humanitarian relief."²² Offense, defense, and stability operations are described in greater detail in their respective doctrinal series of manuals.²³

The Army executes decisive action by means of its core competencies, combined arms maneuver (CAM)²⁴ and wide area security (WAS).²⁵ ADRP 3-0 describes these two activities, as "inseparable and simultaneous," maintaining the idea that offense, defense, and stability are conducted simultaneously, not sequentially.²⁶ Beyond describing these operations as scalable, the ADRP 3-0 does not explain how stability and offense operations can coexist.

²⁰Department of the Army Headquarters, Army Doctrine Publication (ADP) 3-0, *Unified Land Operations* (Washington, DC: Government Printing Office, 2011), 5.

²¹*Ibid.*, 6.

²²Benson, 6.

²³Army manuals that deal with offense and defense end in with 3-90 (ex. ADP 3-90), while those that deal with stability end with 3-07.

²⁴Headquarters, Army Doctrine Reference Publication (ADRP) 3-0, *Unified Land Operations*, 2-9. CAM can be thought of as "traditional" warfare. It is the method of operation where the Army focuses on defeat mechanisms, the "method through which friendly forces accomplish their mission against the enemy opposition."

²⁵Headquarters, Army Doctrine Publication (ADP) 3-0, *Unified Land Operations*, 2-9. WAS represents the experiences in Iraq and Afghanistan and focuses on stability mechanisms, the "method through which friendly forces affect civilians in order to attain conditions that support establishing a lasting, stable peace."

²⁶*Ibid.*

The Army's stability doctrine (3-07 series) provides the framework of stability tasks the Army *may* be required to execute.²⁷ The doctrine ranges from conceptual guidance to lists of stability tasks, describing some tasks as minimum-essential. During major operations,²⁸ commanders are told to plan early, collaborating with partners "experienced in incorporating organizational elements."²⁹ The doctrine refers to three composite organizations consisting of both civil and military personnel, as potential partners, these include provincial reconstruction teams (PRTs),³⁰ field advance civilian teams (FACTs), or disaster assistance response teams (DARTs).³¹ None of these organizations participated in the invasion of Iraq, FACTs and DARTs did not exist and PRTs were only employed in Afghanistan.

ADRP 3-0 specifically addresses a failed state as a result of military or existing socioeconomic factors and the increased potential for a military role in stability operations. If toppling a country's ruling body is the military objective, it is likely to produce a failed state, requiring a transitional military authority.³² ADRP 3-0 later clarifies that a transitional military authority should be considered an interim

²⁷ADP 3-07, 10. Caveats exist throughout doctrine stating stability is the responsibility of the "host-nation government or designated civil authority, agencies, and organizations. When this is not possible [due to capacity, capability, or removal], military forces provide essential services...until a civil authority . . . can."

²⁸JP 3-0, GL-12. A series of tactical actions (battles, engagements, strikes) conducted by combat forces of a single or several Services, coordinated in time and place, to achieve strategic or operational objectives in an operational area.

²⁹Headquarters, Department of the Army, Army Techniques Publication (ATP) 3-07.5, *Stability Techniques* (Washington DC: Government Printing Office, 2012), 1-2.

³⁰PRTs were not introduced into Iraq until 2005, thus were not part of the initial invasion. Spc. Zechariah Gerhard, *PRT Legacy Documentary* (Iraq, 2011), <http://www.dvidshub.net/video/123685/prt-legacy-documentary#.Uvu7Xf2QIzk> (accessed 12 February 2014).

³¹Office of the Spokesman, Department of State, "President Issues Directive to Improve the United States' Capacity to Manage Reconstruction and Stability Efforts" (Department of State, 14 December 2005) <https://www.fas.org/irp/offdocs/nspd/nspd-44fs.htm> (accessed 12 February 2014). Created by President Bush in 2005 as part of NSPD 44, directing the Department of State to create the capability to integrate with military contingency plans.

³²Joint Publication (JP) 3-07, *Stability Operations*, Washington, DC: Government Printing Office, 2011, III-50.

solution, but acknowledges that during that time the military assumes full responsibility of the requisite stability tasks.

Doctrine's narrative produces a tension for military commanders and planners. There is clear a message that other government agencies, such as DOS, USAID, UN, possess overall responsibility for stability operations.³³ The message has a caveat; the military must be ready to assume the complete control of stability operations.³⁴ The former requires focus on planning and coordination to achieve the unity of effort, failure to do so risks of negatively impacting military success.³⁵ The latter will impact planning assumptions regarding the size of the force, command structure, and logistics requirements.

The History

The need for simultaneity of stability and offense places an additional burden on military commanders. General Dwight D. Eisenhower described this in a letter to General George C. Marshall, noting "The sooner I can get rid of all these questions that are outside the military in scope, the happier I will be! Sometimes I think I live ten years each week, of which at least nine are absorbed in political and economic matters."³⁶ Despite the burden, Eisenhower understood that activities in his area of operations affected the military situation; therefore, he requested control of both military and stability operations.³⁷

³³JP 3-07, vii. "The Department of State (DOS) is charged with responsibility for leading a whole-of-government approach for stabilization."

³⁴Ibid., 1-2. "Joint forces may lead stabilization activities until other USG agencies, foreign governments and security forces, or IGOs assume the role. The conduct of stability operations is a core US military mission that the Armed Forces are prepared to conduct with proficiency equivalent to combat operations."

³⁵Thijs Brocades Zaalberg, *Soldiers and Civil Power: Supporting or Substituting Civil Authorities in Modern Peace Operations* (Amsterdam, NE: Amsterdam University Press, 2006), 27. This is illustrated by Eisenhower's comment to Marshall regarding civilian agencies in North Africa, he was having "as much trouble with civilian forces behind aiding us as I am with the enemy in front of us."

³⁶Coles and Weinberg, 3.

³⁷Ibid., 43.

Eisenhower was not the first to recognize the necessity for the military control of stability operations. Nearly one hundred years earlier, President James Polk charged General Winfield Scott to invade Mexico, by way of Vera Cruz, in order to capture Mexico City and force an end to the war. Scott's dilemma was that in order to get to Mexico City, he needed to march his small force 234 miles through enemy territory with an ocean at his back.³⁸ Because of the small size of his force, he needed to find efficiencies to allow the maximization of his forces potential. One solution limited the number of troops protecting his lines of communication. Scott understood his success "required... law and order prevail in the towns and cities through which his communications passed."³⁹ By pacifying the population, he limited the amount of combat power needed to secure his supply lines.

Scott's method went beyond simply controlling the population, his methods focused on controlling the behavior of his own soldiers.⁴⁰ By eliminating looting and other malign activities, Scott actually co-opted the population, and utilized the resources they willingly provided to facilitate his combat operations. He effectively bolstered his lines of communication, extending his operational reach. "Above all Scott demonstrated how military strategy and a civil affairs plan can be blended into a mutually supporting pattern."⁴¹ Scott's actions and General Order 20 (GO 20) is an example of how stability operations can enable offensive operations. During the Civil War Union commanders, as they

³⁸Timothy D. Johnson, *A Gallant Little Army: The Mexico City Campaign*, Modern War Studies (Lawrence, KS: University Press of Kansas, 2007), 3.

³⁹William E. Daugherty and Marshall Andrews, *A Review of US Historical Experience with Civil Affairs: 1776-1954* (Johns Hopkins University; Operations Research Office, 1961), 84.

⁴⁰Karl Jack Bauer, *The Mexican War, 1846-1848* (Lincoln, NE: University of Nebraska Press, 1992), 326. General Order (GO) 20 "These included military commissions to try Americans charged with crimes which, if committed in the United states, would have been 'tried and severely punished by the ordinary or civil courts of the land,'" including murder, rape, robbery, theft, desecration of churches, and destruction of private property. The military commissions had jurisdiction over cases involving both Americans and Mexicans."

⁴¹Daugherty and Andrews, 86.

invaded the southern states also faced issues beyond the military scope.⁴² Union generals in occupied territories were “concerned with such problems as the care and relief of refugees (freed slaves); the recruitment of civilian labor; the censorship of news media; the supervision of such civil courts as remained open; the appointment of local government officials possessing Union sympathies; and the control of many aspects of civilian economy.”⁴³

Upon the occupation of large areas of the southern states, President Lincoln commissioned prominent politicians as general officers and appointed military governors⁴⁴ over occupied territories divided by state lines. There was not a common consensus between Union generals as to how to treat the citizens of the south.⁴⁵ To address this Lincoln published the Lieber Code⁴⁶ to provide commanders with a standard policy for handling civil affairs.⁴⁷ The Lieber Code, like Scott’s GO 20, established rules of conduct for both combatants and non-combatants alike.⁴⁸ Unlike Scott’s GO 20, it gained the attention of the generals and statesmen of Europe and profoundly impacted the Hague Convention of 1899, providing

⁴²Ibid., 118.

⁴³Ibid., 121.

⁴⁴Ibid.

⁴⁵Ibid., 94–95.

⁴⁶Also known as the Instructions for the Government of Armies of the United States in the Field, General Order 100, United States War Department, *The War of the Rebellion: A Compilation of the Official Records of the Union and Confederate Armies*, Vol. 3, III (Washington DC: Government Printing Office, 1899), <http://ehistory.osu.edu/osu/sources/recordView.cfm?page=148&dir=124> (accessed 10 February 2014).

⁴⁷Karen Rochelle Guttieri, “Toward a Usable Peace : United States Civil Affairs in Post-conflict Environments” (Dissertation, University of British Columbia, 1999), 78, <https://circle.ubc.ca/handle/2429/9989> (accessed 26 January 2014).

⁴⁸John Fabian Witt, *Lincoln’s Code: The Laws of War in American History* (New York: Free Press, 2012), 2.

“the foundation of the modern laws of war...”⁴⁹ The Lieber Code set the foundation for United States civil affairs doctrine.⁵⁰

In 1898, after defeating the Spanish, the US Military occupied Cuba, Haiti, and the Philippians. In Cuba, the Army’s lack of experience rendered commanders ill-equipped to handle the civil affairs problems, resulting in combat troops used for labor details.⁵¹ An example of this is found in the writings of General Shafner’s in Cuba. In these writings he described that his forces experienced a shortage of transportation because he “had already diverted much of what he had originally possessed in order to assist the Red Cross in accomplishing its mission of Mercy [to support the thousands of refugees].”⁵²

In the Philippines, commanders lacked appropriate guidance about the political status of the Philippines following the defeat of the Spanish due to the indecisiveness of policymakers.⁵³ Consequently, the indigenous population distrusted the military occupiers, which resulted in the US forces fighting an insurgency.⁵⁴ “However this failure to anticipate in advance the requirements and to provide men in the field complete policy guidance did not prevent aggressive talented men...from making a lasting contribution to the welfare of the people governed...”⁵⁵ The experiences of these talented men, included Governor-General Henry Stimson and Captain George Marshall, shaped civil affairs and military governance during World War II.⁵⁶

Following the armistice of World War I, US troops administered the Rhineland region of occupied Germany. At this time commanders viewed civil affairs of missions to be outside the scope of

⁴⁹Ibid., 3.

⁵⁰Daugherty and Andrews, 121.

⁵¹Ibid., 153.

⁵²Ibid., 125.

⁵³Ibid., 153.

⁵⁴Ibid., 145.

⁵⁵Ibid., 154.

⁵⁶Brocades Zaalberg, 26.

the military operational, civil affairs planning and execution was “ad hoc and disorganized.”⁵⁷ While successful in Germany, some feared fault with the Army’s ad hoc attitude towards civil affairs and military governance. According to Colonel Irwin L. Hunt, “The American army of occupation lacked both training and organization to guide the destinies of the nearly one million civilians whom the fortunes of war had placed under its temporary sovereignty.”⁵⁸ Colonel Hunt recommended that the Army proactively prepare for occupation duty, as well as, “develop competence in civil administration among its officers during peacetime.”⁵⁹ Colonel Hunt’s report, commonly referred to as the Hunt Report, inculcated the Army’s belief⁶⁰ that the governing of occupied territory was “more than a minor incidental of war.”⁶¹

In 1940, using the Army’s experiences in the Rhineland as the model, the War Department published Field Manual (FM) 27-5, *Basic Field Manual on Military Government*. This manual, using the “liberal and humane spirit of Lieber’s Code and the Hague Conventions”⁶² outlined five basic policies concerning military necessity: welfare of the governed, flexibility, economy of effort, and permanence. Additionally FM 27-5 details the following ancillary policies:

- (a) The commanding general of a theater of operations should be in full control of military government in his theater
- (b) Separate personnel for military government should be provided as long as hostilities exist, and personnel of combat units should be assigned to military government duties only when the resumption of hostilities is extremely remote.

⁵⁷Kathleen Hicks and Christine Wormuth, *The Future of U.S. Civil Affairs Forces* (Washington, DC: Center for Strategic and International Studies, February 2009), 3.

⁵⁸Earl F. Ziemke, *U.S. Army in the Occupation of Germany, 1944-1946* (Washington DC: Office of the Chief of Military History, 1975), 3.

⁵⁹*Ibid.*

⁶⁰Nicholas J. Schlosser, “The Marine Corps’ Small Wars Manual: An Old Solution to a New Challenge?,” *Fortitudine* 35, no. 1 (2010): 4–9 Small Wars Manual, first published in 1939, captured the Marine’s experiences with counterinsurgency operations in Central America and the Caribbean.

⁶¹Ziemke, 3.

⁶²Daugherty and Andrews, 197.

(c) The personnel of military government should, so far as possible, deal with the inhabitants through the officers and employees of their own government.

(d) Military government should avoid “making changes in existing laws, customs, and institutions.”⁶³

FM 27-5 also had its critics. Many criticized it for its “emphasis on the welfare of the population and not addressing the importance of the military operation.”⁶⁴ Despite this criticism, the manual was not revised until 1945. In the interim, planners used it as the basis for their military governance planning, it with any explicit or implicit policy guidance they received.

In 1942, General George C. Marshall, now the Army’s Chief of Staff, established the School of Military Government with Brigadier General Cornelius Wickersham as its Commandant.⁶⁵ The school, located at the University of Virginia in Charlottesville, Virginia, modeled itself after earlier British officer training for occupation duty. However, while the British school focused on socio-political factors, the US school focused on more practical matters including “sewage disposal and the interior organization of the Nazi Party.”⁶⁶ The initial student population of 50 senior officers, soon grew to a class size “averaging 175-200 students” completing the three month school⁶⁷

The Army believed it satisfied the recommendations of the Hunt Report; and developing an internal capacity for occupation duties, as well as a doctrinal foundation for planning. Some believed the Army had no business governing civilian population, despite these preparations. In both political and military circles alike some believed “...civil administration was regarded as a task unsuited for military

⁶³Ibid., 198.

⁶⁴Ibid., 201–202.

⁶⁵Brocades Zaalberg, 26.

⁶⁶Stanley Sandler, *Glad to See Them Come and Sorry to See Them Go* (Washington, DC: Government Printing Office, 2004), 170. This theme reverberated throughout World War II.

⁶⁷Ibid.

forces.”⁶⁸ The Army’s efforts ignited a debate among policy makers, about the military’s role in occupation.

SECTION 2: THE AFRICAN THEATER: WHO SHOULD BE IN CHARGE OF OCCUPATION?

In light of the historic evidence presented, why was this matter of the military’s role in occupation so rigorously contested? Authors Coles and Weinberg believe that the arguments for, or against, can be distilled to one thing—values.⁶⁹ The situation in Africa became a contest of ideology versus practicality. President Roosevelt believed “the concept of civil affairs administered by military personnel was both strange and abhorrent.”⁷⁰ On the other hand, Secretary Stimson saw “such operations were but the natural and inevitable consequences of military operations where there was no fully effective friendly government.”⁷¹ The military did not argue for indefinite control of occupied territories, but it cautioned against the “unwisdom of premature civilian interference.”⁷² The matter was settled in Africa, regardless of arguments surrounding the issue.

Africa: The Fight for Military Control of Civil Affairs

For President Roosevelt World War II became a war of ideals. “It was waged to fulfill the promises of self-determination as laid down in the Atlantic Charter and the United Nations Declaration. Replacing totalitarian rule with Allied military government was therefore by no means the obvious choice.”⁷³ Therefore, he gave the Department of State responsibility of administering occupied and liberated territories, he allowed the Army to continue training civil affairs officers.

⁶⁸Brocades Zaalberg, 26.

⁶⁹Coles and Weinberg, x.

⁷⁰Daugherty and Andrews, 215.

⁷¹Ibid.

⁷²Coles and Weinberg, 15.

⁷³Brocades Zaalberg, 26.

With the planning for Operation Torch well underway, Secretary of State Cordell Hull ordered Robert D. Murphy, to integrate his mission into the military's. In reality, Murphy did not serve in any capacity to assist in the planning of the invasion of North Africa. He only met with Eisenhower for a brief 24-hours before undertaking another secret mission in French North Africa. Dr. H. Freeman Matthews, Eisenhower's political advisor, served as acting chief of the planning section. Ultimately, the section accomplished little civil affairs planning prior to the invasion."⁷⁴

The friction between Murphy and Eisenhower was not personal; but stemmed from the performance expectations. Murphy was a member of Eisenhower's staff, expected to report to the commander on civil affairs matters, but this was not his only position. He was also a Foreign Service officer, responsible to the State Department. Finally, he was the President's personal representative to North Africa. Murphy's conflicting positions did not facilitate unity of effort, much less command. This lack of unity greatly concerned Eisenhower.⁷⁵ Eisenhower found, based on military necessity, he had to make policy decisions. Some of his decisions conflicted desires of Allied political leadership.⁷⁶

During Operation TORCH, the Joint Chiefs continuously attempted to delineate responsibility for civil administration between the civilian agencies and the military. Whether it was economic issues, civil administration, or finally civil relief supplies, every attempt to limit the scope of the Army's involvement

⁷⁴Daugherty and Andrews, 204.

⁷⁵Coles and Weinberg, 32. On September 19th, 1942, after having read Murphy's directives Eisenhower wrote to Marshall to express concern about the divided responsibilities "Prior to the commencement of the special operation it is essential that Murphy have status as the President's personal representative in that area. There is a possibility that unless the directive is revised as indicated, there may develop in the minds of the French officials, after my arrival, the idea that there is division of authority between the American civil and military officials."

⁷⁶Daugherty and Andrews, 206. Eisenhower's decision to place French General Darlan in charge of Tunisia was highly contentious. Darlan was part of the Vichy government, thus seen as a Nazi sympathizer. The alternative, in Eisenhower's eyes was to establish a military government. When Eisenhower looked to Murphy for a decision, Murphy replied, "The whole matter has become a military one. You will have to give the answer." Eisenhower believed the Allies "could not afford a military occupation, unless we chose to halt all action against the Axis." Both Washington and London did not like the decision, but not wishing to interrupt military operations let it stand.

in Civil Affairs faced a situation requiring a decision from Eisenhower.⁷⁷ In North Africa, the answer was quite clear, in Eisenhower's words "No one could be more anxious than General Clark and myself to rid ourselves completely of all problems other than purely military, but the fact remains that, at this moment and until North Africa is made thoroughly secure...everything done here directly affects the military situation..."⁷⁸ Eisenhower proposed to subordinate the State Department's operations under the military headquarters. Murphy agreed with Eisenhower's recommendation.⁷⁹

By November of 1943, President Roosevelt faced mounting evidence that civilian control during combat operations was impractical. The President reversed his decision because of growing pressure from his military subordinates calling for unity of command, and civilian failures to coordinate postwar supply distribution. In a letter to Secretary Stimson, he wrote, "Although our agencies of the government are preparing themselves for the work that must be done in connection with the relief and rehabilitation of liberated areas, it is quite apparent if prompt results are to be obtained the Army will have to assume the initial burden of shipping and distributing relief supplies."⁸⁰

During Operation Torch military and civilian leaders learned two significant lessons regarding the execution of civil affairs. The first lesson, any civil affairs action conducted in a theater of operation impacts military operations, making it impossible for military commanders to divorce themselves from civil affairs. The second, unity of command applies not only to combat operations, but to any activity that may impact those military operations. For Coles and Weinberg "what is most important is the fact, little noticed at the outset, that Torch put the theory of civilian control to its first test and resulted in certain

⁷⁷Coles and Weinberg, Chapter II.

⁷⁸Ibid., 43.

⁷⁹Ibid.

⁸⁰Ziemke, 203.

conclusions which affected all later civil affairs planning. Its logical conclusion it would mean the acceptance of the theater commander's control through an administration of purely military character."⁸¹

SECTION 3: SICILY AND ITALY: THE TESTING GROUND FOR CIVIL AFFAIRS

[The invasion of Italy] will inevitably establish precedents far-reaching in scope and importance and will set the pattern for later Operations in Europe. Policies now adopted will affect future operations throughout the war. We must therefore reconcile American and British policy toward Italy in order that there may be a joint and single attitude with respect to the civil and military authority and the civil population of the territory occupied. It must be decided whether a benevolent policy or one of strict military occupation in Sicily will contribute more to the rapid submission of the balance of the county.

General Eisenhower⁸²

The invasion of Sicily, Operation HUSKY, marked the first time the US Army was responsible for both the invasion and the occupation of enemy held territory. For the British, it was the first operation without intent to establish a colony.⁸³ Civil Affairs operations in the Mediterranean Theater provided many experiences, both positive and negative, that later informed planning in other theaters.⁸⁴ This monograph focuses on key lessons that effected the planning for the invasion of Northwestern Europe. These lessons fall into the fallowing categories; organization, command and control, and the execution.

Unlike Africa, the British and Americans shared the responsibility for the occupation of Italy, resulting in a conglomeration of ideas that drove the planning and execution for the occupation. Additionally, London and Washington at times disagreed on matters of policy, which delayed decisions required by Allied military leadership.⁸⁵ This lack of policy concerned Eisenhower, as illustrated in the

⁸¹Coles and Weinberg, 31.

⁸²Ibid., 160.

⁸³Ibid.

⁸⁴Daugherty and Andrews, 258.

⁸⁵Coles and Weinberg, 160.

quote above. The two major questions he needed answered were: was the character of the military government to be benevolent or strict, and was the British or the United States to be responsible for it?⁸⁶

Organization

The US's Civil Affairs Division

In March 1943, prior to the President's decision to give the military full control of civil affairs, the War Department identified the requirement for a clearinghouse for "civil affairs matters referred by commanders in the field."⁸⁷ To address this need, the War Department created the Civil Affairs Division (CAD),⁸⁸ a multi-agency organization, led by Major General John Hilldring. CAD was designed to "inform and advise the Secretary of War in regards to all matters within the purview of the War Department, other than those of a strictly military nature, in areas occupied as a result of military operations."⁸⁹ After the President's decision, the CAD's role expanded to include responsibility for planning and execution of "interim rule in the Mediterranean, northwestern European and Pacific theaters."⁹⁰ It was through the CAD that Department of State, who was still responsible for the creation of occupation policy, provided input to the War Department.⁹¹

Hilldring provided context for the military's role in civil affairs. He sought to emphasize the "operational primacy of civil affairs."⁹² In a US congressional committee meeting Hilldring described military civil affairs as having two primary tasks. The first was to "secure the civilian populations [and

⁸⁶Daugherty and Andrews, 238.

⁸⁷Coles and Weinberg, *Civil Affairs*, 66.

⁸⁸*Ibid.*, 114-119. It is important to note, the CAD was strictly an American military organization. Policy creation is a delicate matter for a coalition. Several organizations were created both in Washington D.C. and London that would govern the creation of occupation policy.

⁸⁹*Ibid.*, 68.

⁹⁰Brocades Zaalberg, 27.

⁹¹*Ibid.*

⁹²*Ibid.*, 28.

maintain law and order] to the maximum extent possible, which is an obligation of international law.”⁹³

The second task was to “prevent civilian population from interfering with military operations.”⁹⁴

The FM 27-5 captured these principles in its revision of 1943. The new manual differed from its predecessor and evolved into a product of the combat tested requirements of civil affairs and military government during hostilities.⁹⁵ The revised manual concentrated more on the execution of civil affairs during combat and emphasis that civil affairs supported combat operations.⁹⁶ It also hardened the attitude towards the populations in occupied territories, and addressed the potential need to remove political individuals on the basis of their party affiliation, such as Nazi or Fascist.⁹⁷ Critics admonished its over-emphasis on the combat phase, neglecting the post-hostility phase, and its ambiguity when dealing with policy issues.⁹⁸

Military Government Planning in the African Headquarters (AFHQ)

In January 1943, with the understanding that military governance was now an “essential requirement,” Eisenhower tasked the Liaison Section AFHQ, under Colonel Julius Holmes,⁹⁹ with responsibility for military government planning.¹⁰⁰ The section’s first effort first was devised the method

⁹³Ibid.

⁹⁴Ibid.

⁹⁵Daugherty and Andrews, 234.

⁹⁶Ibid.

⁹⁷Ibid., 235. While the welfare of the inhabitants should be considered for humane reasons and should be safeguarded as far as military requirements permit, the primary purposes of such treatment are to facilitate the military operations and to meet obligations imposed by law.... Such a policy, however, should not affect the imposition of such restrictive or punitive measures as may be necessary to accomplish the objectives of military government in any area, but especially in one in which the population is aggressively hostile and engages in active and passive sabotage

⁹⁸Ibid., 236.

⁹⁹Ibid., 238. Holms was a former State Department Foreign Service Officer who had served as an interpreter and assistant in handling civil affairs in North Africa.

¹⁰⁰Ibid.

for the Allies to establish the military government in Sicily and later Italy. To accomplish this task, Holmes dispatched one of his planners to Tripolitania, to observe the British military government.

By March, Holmes presented a recommendation to AFHQ Chief of Staff, Major General W. Bedell Smith. Holmes' recommended the utilization of the British military government in Tripolitania as a basis for planning.¹⁰¹ Holmes also recommended that FM 27-5 govern the nature of the occupation, that British and American officers equally man the administrative and field staff, and that the AFHQ be responsible for all policy and political matters of the military government.¹⁰²

Eisenhower's staff shared the plan with Allied military leaders and the political leaders in London, and Washington. Holms himself brought the plan to Washington to get further policy guidance from the State Department, which failed to provide any such guidance. When Holms asked Hilldring what he should do, Hilldring told Holmes, "General Eisenhower had to write the directive if anyone did. The War Department at that time had no place to do it. State wouldn't. The only way you can get [a policy directive] was to write it yourself."¹⁰³

One of the major discussions about the plan revolved around the idea of direct or indirect rule.¹⁰⁴ Direct rule called for the military personnel to take direct control of civil administrations. This was deemed too manpower intensive, thus military leaders preferred to control through local civilian

¹⁰¹CAD files, 091.i, Tripolitania; Coles and Weinberg, 161. "Under the system developed by the British, administration in occupied areas was placed in the hands of a Deputy Chief Political Officer (DCPO) who also acted as adviser to the military governor—the commanding general in each instance. The staff was divided into three main sections—legal, finance, and police. When military operations ceased, the DCPO became military governor. In the field, the DCPO was assisted by political officers who went forward with the occupying forces. As soon as military operations permitted, a political officer took over the office of the mayor of a designated area and acted as chief municipal officer. A police force independent of military police was established, of military police was established, staffed at the top by civilian inspectors while the remainder of the force was recruited from local personnel. The civil police force, usually disarmed, assumed responsibility for civilian functions."

¹⁰²Ibid.

¹⁰³Daugherty and Andrews, 240.

¹⁰⁴Coles and Weinberg, 170.

intermediaries, indirect rule.¹⁰⁵ Indirect rule presented the question of how to choose whom to place in the positions of control, such as a mayor or prefect, because the persons most qualified were often Fascists. British Major General Lord Rennel argued “it would be desirable to maintain the Italian administrative machinery intact” despite their affiliation.¹⁰⁶ To do otherwise would undermined the Allies efforts, citing “the intrusion into the intimate details of local administration might have created popular resentment leading to complete administrative chaos.”¹⁰⁷

The shortage of civil affairs personnel the decision necessitated to accept indirect rule through standing civilian authorities.¹⁰⁸ Roosevelt and Church agreed that the most belligerent and Facists in high positions be removed. Beyond that, they gave Eisenhower the authority to decide which Fascists to replace by military officers.¹⁰⁹

Organization: Allied Military Government of Occupied Territory

The role of political personnel in military formations was another point of contention between Washington and London. The question revolved around a philosophical disagreement between the British and Americans. The British maintained political advisors in their military formations. One such advisor, Mr. Macmillan, at the Allied Headquarters, expected Eisenhower to consult with him on any political matters.¹¹⁰ Both the US Department of State and War “opposed political representatives in [the military] chain of command.”¹¹¹

¹⁰⁵Daugherty and Andrews, 242.

¹⁰⁶Ibid., 241.

¹⁰⁷Ibid., 242.

¹⁰⁸Ibid., 257.

¹⁰⁹Coles and Weinberg, 173.

¹¹⁰Ibid., 174.

¹¹¹Ibid.

The solution created a combined British and American Headquarters, divested of any political agency, took its directives from the Combined Chiefs of Staff (CCS).¹¹² Eisenhower established his headquarters and assumed responsibility to report to both British and American governments. The CCS provided Eisenhower with polices dealing with political, financial, and economic matters.¹¹³ In May of 1943, two months prior to Operation HUSKY, the Allied Military Government of Occupied Territory (AMGOT) was created as part of AFHQ.

The AMGOT was assigned to Force 141 and commanded by British General Sir Harold Alexander, “military governor-to-be of Sicily,”¹¹⁴ and led by Chief Civil Affairs Officer, British Major General Lord Rennell.¹¹⁵ Its specific objectives were to secure lines of communication, restore law and order, provide relief to civilians, and relieve combat troops of the need to provide civil administration. It also assisted in providing occupying forces resources from the occupied territory, and promoted the political and military objectives of the Allied forces to set conditions for future operations.¹¹⁶

The AMGOT consisted of nearly 400 officers, organized into six special divisions, legal, financial, civil supply, public health, public safety, and enemy property. It had two types of civil affairs officers (CAO), generalists and specialists. Generalists were those “responsible for the supervision of municipalities.”¹¹⁷ The specialists were those whose expertise fell into one of the six special divisions.

¹¹²Richard M Leighton, *United States in World War II- The War Department-Global Logistics and Strategy 1940-1943* (Washington DC: Center of Military History, n.d.), 143. The CCS was the supreme military staff for the western Allies during World War II. It emerged from the meetings of the Arcadia Conference in December 1941.

¹¹³Coles and Weinberg, 166.

¹¹⁴Daugherty and Andrews, 242.

¹¹⁵Coles and Weinberg, 166. The decision to have the AMGOT lead by two British generals was a political one designed to maintain representation of officers from both countries in the chain of command. US Brigadier General Frank J. McSherry was appointed the Deputy Chief Civil Affairs Officer.

¹¹⁶Coles and Weinberg, 182.

¹¹⁷Daugherty and Andrews, 242.

For the initial phase of the invasion, the AMGOT assigned civil affairs officers from the AMGOT to task forces to act as staff officers for the tactical commander. Upon landing, these officers assumed responsibility for captured towns, and begin reporting to the AMGOT.

In addition to the AMGOT, the War Department directed Eisenhower to establish a civil affairs/military government staff section. AFHQ created a Military Government section, later called the G5. Renell feared that the newly created G5 section might try to intervene in “the operational affairs of lower echelons.”¹¹⁸ To reassure him, Smith issued verbal orders to Holmes to ensure that his staff did not interfere with AMGOT operations.¹¹⁹

Command and Control

Establishing a military government was an operation that was unique in character and requiring personnel with as specific set of virtues different from those of regular combat personnel. “Flexibility and improvisation were the key virtues of the civil affairs officer, arguably more than regular combat personnel whose mission, however difficult, was relatively straightforward-the defeat of the enemy.”¹²⁰ A second argument for separate chain of commands was the need to ensure uniform military government policy across the entire area of operation.¹²¹ Because of this, the command and control of military government was separate from the combat commanders. As part of Force 141, AMGOT reported directly Eisenhower through the AFHQ G5 and had no formal responsibilities to the individual army commanders.

The lack of formal command and control relationships between the AMGOT and the combat commands, coupled with the AMGOT’s late creation, caused confusion with the British Eighth, and US

¹¹⁸Ibid., 243.

¹¹⁹Charles Reginald Schiller Harris, *Allied Military Administration of Italy, 1943-1945* (London: H. M. Stationery Office, 1957), 9.

¹²⁰Brocades Zaalberg, 30.

¹²¹Ibid., 31.

Seventh, army commanders. Neither command fully understand what the AMGOT was, or how to incorporate the CAOs into their operations.¹²² Military government operations were never fully synchronized with combat operations. Realizing their mutual failures, the AMGOT and combat commands would take steps to improve the integration of military government personnel into combat operations.

Despite the overall success of the AMGOT, not everyone was convinced that two separate chains of command was the best method.¹²³ It was largely agreed that civil affairs troops were essential, by relieving combat troops of the responsibilities of civil control.¹²⁴ But the separate chain of command system also “endangered ‘unity of command.’”¹²⁵ Commanders below the Supreme headquarters did not like the fact that they could not control the civil affairs units “that were roaming through their area of operations.”¹²⁶ For the civil affairs units, by not being part of the combat commands, they had limited access to army resources, often times having to “beg like a stranger” for engineer, transportation, and relief supplies.¹²⁷

Unlike Sicily, the armies in Italy took greater interest in the activities of the military governments in their respective areas. Both the British Eighth and US Fifth armies maintained liaisons with the Allied Control Commission (The ACC replaced the AMGOT).¹²⁸ Each army created its own special staff to provide an internal military government capacity.¹²⁹ In turn, the AMGOT reorganized how it employed its CAOs to better support combat operations. Because of these changes, it was found that the lion’s share

¹²²Daugherty and Andrews, 249.

¹²³Sandler, 176.

¹²⁴Daugherty and Andrews, 258.

¹²⁵Brocades Zaalberg, 31.

¹²⁶Ibid.

¹²⁷Ibid.

¹²⁸Daugherty and Andrews, 252.

¹²⁹Sandler, 177.

of “reconstruction and reformation of the Italian government machinery took place during the initial or assault phased of military operations.”¹³⁰ As a result, it was the combat units who “set the tone of military government policy in Italy.”¹³¹

Execution

The plan was for the CAOs to travel with advancing combat units. As combat forces occupied territory, the CAO teams stayed behind to administer control of that territory, under the direction of the AMGOT. Their functions included labor procurement to support combat troop logistic operations, refugee management, civilian relief, public safety/public order, and protection of arts, monuments, and archives.¹³² Unfortunately, having only been in existence for two months prior to D-day (and five months after the decision to go to Sicily was made), the AMGOT had difficulty integrating into the operational plan.

During Operation HUSKY, commanders of the Eighth and the Seventh Armies did not understand the function of the AMGOT or its CAOs; therefore the Army staffs excluded CAOs from assault operations, CAOs not included in the initial waves on D-day.¹³³ CAOs, attached to their combat units at the last minute attachment failed to integrated in any of the army’s support plans.¹³⁴

The British Eighth Army landed with 30 CAOs, only because those CAOs smuggled themselves onto landing craft. After realizing his error, the British commander requested additional assets but their arrival was delayed by several weeks.¹³⁵ The Seventh Army’s situation was worse; they landed with only

¹³⁰Daugherty and Andrews, 251.

¹³¹Ibid.

¹³²Daugherty and Andrews, 253–255.

¹³³Ibid., 249.

¹³⁴Ibid.

¹³⁵Ibid., 244.

ten CAOs, with the other twenty left behind to make room for more combat troops.¹³⁶ Even those CAOs who made it to shore did not come with enablers. They had no enlisted men, interpreters, guards, or equipment to assist them in their missions.¹³⁷ Often, after liberating a town, a single CAO was left behind to administer control of an entire village.¹³⁸

To correct the shortfalls experienced in Sicily, civil affairs planners made a series of changes to support operations in Italy. Provisional military government headquarters were staffed with technical specialists and positioned to be called forward in the wake of battle. These specialists attempted to control the population and provide basic essential services to civilian population. These detachments moved in “support of the commander’s mission” which was the key difference from what was done in Sicily.¹³⁹ A small group of generalists stayed behind to continue to support the community.

By default, The Mediterranean Theater became the testing ground for Allied civil affairs.¹⁴⁰ It provided the Allies the opportunity to gain experience in both planning and execution of military governments. More importantly, the experiences of Sicily and Italy shaped the vision for one man, Eisenhower’s Chief of Staff Bedell Smith, who played a much larger role in military government operations during the invasion of Northwest Europe.

SECTION 4: THE EUROPEAN THEATER

The occupation of Germany is a successful example from which military leaders and planners can learn.¹⁴¹ This Section presents analyze of the planning and execution of civil affairs operations executed during combat, which set the conditions for the occupation. To do this the monograph again analyzes the

¹³⁶Ibid.

¹³⁷Ibid., 249.

¹³⁸Sandler, 177.

¹³⁹Daugherty and Andrews, 254.

¹⁴⁰Brocades Zaalberg, 29.

¹⁴¹Oehrig, 1.

organization structure, command and control, and the execution. It will also explore the impacts the Allies experiences in Italy had on planning.

Unlike Sicily, planners worked on the plan to invade Germany for nearly two years prior to execution. During the Arcadia conference, from December 1941 to January 1942, President Roosevelt publicly announced his Europe First strategy.¹⁴² Despite the Japanese attack on Pearl Harbor, the president decided that Germany was the main effort due to its proximity to the United Kingdom. During the Casablanca conference, nearly a year later, the President Roosevelt declared that nothing short of unconditional surrender by the Axis powers would end the war.¹⁴³ Roosevelt's statement at the Casablanca conference clarified to those in the European Theater of Operations (ETO) that the occupation of Germany had just become a specified military objective for the Allies. Establishing a military government became an implied objective of the occupation.

Organization

Prior to the Casablanca conference, little consideration had been given to civil affairs by the United States Army staff in the European Theater (ETOUSA).¹⁴⁴ In 1942, in response to Europe First, Eisenhower's staff began planning Operation ROUNDUP.¹⁴⁵ As part of the planning effort, the ETOUSA established a civil affairs section under Colonel Arthur B. Wade.¹⁴⁶ Eisenhower, now commander of the

¹⁴²Kennedy Hickman, "World War II: The Postwar World, Ending the Conflict," *About.com Military History*, n.d., <http://militaryhistory.about.com/od/worldwarii/a/wwiipost.htm> (accessed 20 February 2014).

¹⁴³*Ibid.*

¹⁴⁴Ziemke, 24.

¹⁴⁵OCarlo D'Este, *Decision in Normandy* (New York: Konecky & Konecky, 1994), 24–35. Operation ROUNDUP was Eisenhower's 1942 plan to invade France. The Allied decision to invade Africa first would lead to ROUNDUP being shelved.

¹⁴⁶Ziemke, 24. The creation of the ETOUSA G5 was prompted by the existence of the British Administration of Territories (Europe) Committee (AT(E)), a group created in July to deal with civil affairs planning for ROUNDUP. Not wanting the British to dominate civil affairs planning the US saw the need to create their own civil affairs planning organization to represent US concerns.

ETOUSA, understood the need for a Deputy Chief Civil Affairs Officer and sought recommendations. Before he could make the appointment, ROUNDUP gave way to TORCH which stalled the development of a civil affairs capability.

It must be highlighted that Operation ROUNDUP was planned in 1942, well before operations in Africa and the creation of CAD. Even without the experiences of the African and Mediterranean Theaters, Eisenhower and his staff understood the necessary to create a capacity for civil affairs within their headquarters. This demonstrated an institutional belief that military government was a core mission within military operations.¹⁴⁷ “In early 1943 the Civil Affairs Section had no coherent organization and no mission other than general instructions to follow the principles of FM 27-5.”¹⁴⁸

During the Casablanca conference in January 1943, the Allies decided to invade France following the Mediterranean campaign. In April, the ETOUSA received a new chief of staff, British Lieutenant General Sir Frederick E. Morgan. As the Chief of Staff to the Supreme Allied Commander (COSSAC) he developed plans to invade Germany.¹⁴⁹ Acting as the supreme commander, Morgan and his combined staff of British and American officers planned of the invasion of the European continent, Operation OVERLORD.

Morgan created detailed plans for several contingencies including a “plan for a possible German collapse or partial collapse at any time before the spring of 1944.”¹⁵⁰ For Morgan, this contingency “suggested the need for military government, one of his early conclusions as COSSAC was that no such capability existed.”¹⁵¹ Subsequently, Morgan requested from the War Department “an urgent requirement for a civil affairs headquarters and an operating organization equipped with a coherent body of policy

¹⁴⁷Ibid., 24. “In previous wars US military government had always been a field operation carried out with minimum direction from Army headquarters.”

¹⁴⁸Ibid., 23.

¹⁴⁹Ziemke, 25.

¹⁵⁰Ibid., 26.

¹⁵¹Ibid.

procedure.”¹⁵² Due to the unfortunate timing of Morgan’s request, he did not receive the help he requested; his staff would have to plan the occupation of Germany on their own.¹⁵³

In light of British intelligence estimating that Germany was desperate and perhaps on the verge of collapse, Morgan felt he could not wait for the resources, in whatever form, and began to plan for the occupation of Germany.¹⁵⁴ Morgan and his staff planned three different contingency cases codenamed RANKIN. Case A and B “were concerned with the prospects of an invasion before 1 May 1944.... Case C dealt with the possibility of an unconditional German surrender.”¹⁵⁵ Unlike Case A and B, Case C “was concerned with the end of the war, the beginning of the occupation, and the reorientation of efforts into directions so far had not even been defined, much less explored.”¹⁵⁶

Morgan realized that he lacked a civil affairs organization and policy to conduct the necessary detailed planning for RANKIN C.¹⁵⁷ To address the latter, he urgently requested the British and American governments establish policy “on military government in enemy territory and civil affairs in liberated territory and provide resources with which to execute such policy.”¹⁵⁸ Without waiting for a reply, Morgan built his own civil affairs organization.

As the COSSAC, Morgan built the civil affairs organization that directed activities in the European theater.¹⁵⁹ Morgan later described this task, stating that not only did it “present continual

¹⁵²Ibid.

¹⁵³At this time a decision had not been made regarding the military’s role in occupation duties. While CAD did exist at this time, it was only in infant state and not in a position to begin addressing major decisions.

¹⁵⁴Ziemke, 26. This was due to the Allied successes in Sicily and German failure against the Kursk salient made the possibility of a German collapse less a contingency and more a possibility.

¹⁵⁵Ibid., 27.

¹⁵⁶Ibid., 28.

¹⁵⁷Ibid.

¹⁵⁸Ibid.

¹⁵⁹Daugherty and Andrews, 274.

difficulty, but the evolution of policies and procedures on which that staff was to function was a perpetual nightmare.”¹⁶⁰ For Morgan, the situation in Europe differed from that of Africa and Italy. He saw the African and Italian economic, political, and population conditions bearing “little or no resemblance to that pertaining to Europe.”¹⁶¹ Morgan also believed the concept of co-belligerency,¹⁶² created in Italy, had no place in Germany.¹⁶³ Despite these differences, the lessons learned in Africa and the Mediterranean theaters impacted European civil affairs operations.

Lessons Learned from Italy

In August 1943 Major General Sir Roger Lumly became the chief of the newly formed COSSAC civil affairs section. Using the Mediterranean Theater’s AMGOT as the basis, the civil affairs section formed around a central planning group responsible for the overall planning of the OVERLORD and RANKIN operations. The central planning group also directed four “country houses,” responsible for planning, and future execution in each of its assigned countries, including France, Belgium, the Netherlands and Norway. They assumed Germany would be handled separately and did not account for it.¹⁶⁴

The creation of the COSSAC civil affairs section gave the ETOUSA civil affairs section direction. The commander of ETOUSA, Lieutenant General Jacob L. Devers, provided twenty officers including Colonel Cornelius Ryan who operated as both the ETOUSA’s chief civil affairs officer and the

¹⁶⁰Sir Fredrick Edgworth Morgan, *Overture to Overlord* (Garden City, NY: Doubleday, 1950), 227.

¹⁶¹*Ibid.*

¹⁶²Coles and Weinberg, 230. In September 1943 the Italian people signed an armistice allowing them to be a co-belligerent (an informal partnership between factions) against the Germans and the Fascists. This differed from Germany because of the policy that German people would had equal responsibility for their countries aggression.

¹⁶³Daugherty and Andrews, 274.

¹⁶⁴Ziemke, 28.

acting chief of the US Civil affairs Staff for the COSSAC.¹⁶⁵ At this time, many believed that the yet to be named Supreme Commander would be British. It was important to the ETOUSA to establish a presence within the COSSAC staff to ensure that the US interests were appropriately represented in future civil affair plans.¹⁶⁶

ETOUSA organized its civil affairs section into five departments under the lines of operations of civil relief, military governance, economics, personnel and training, and area research.¹⁶⁷ The fifth department, area research, was unique because it operated as a planning staff and an operational staff. It focused its planning efforts on enemy occupied areas and given the “authority to recommend general and specific policy for military government, and control of civilian supplies and civil affairs personnel.”¹⁶⁸ By September the ETO announced that its civil affairs section was the “final channel of civil affairs authority in the theater with responsibility for all phases of planning for civil affairs in combined operations.”¹⁶⁹

The initial organization of the COSSAC civil affairs section quickly changed drastically. The AMGOT concept fell out of favor. It was not long after it was implemented in September that it resembled “a prize example of the fallacy of permitting two independent commands in the same theater.”¹⁷⁰ Additionally, because of certain political decisions made in Quebec, the concept of country teams became redundant and ultimately an inefficient use of manpower and resources.¹⁷¹

¹⁶⁵Ibid.

¹⁶⁶Ibid., 29.

¹⁶⁷At this time COSSAC was not a combined headquarters, ETOUSA was a separate headquarters that reported directly to the War Department.

¹⁶⁸Morgan, 227.

¹⁶⁹Ibid.

¹⁷⁰Ibid., 30.

¹⁷¹Country teams were separate planning sections meant to act as mini headquarters in charge of planning and policy for France, Belgium Netherlands and France. The decision at the Quebec conference to treat all European countries (with the exception of Germany) as countries to be liberated; therefore control for these countries would be immediately returned their respective governments in exile upon liberation.

In October 1943, COL Karl Bendetsen became the US Chief Staff Officer for the Civil Affairs, COSSAC. Ryan and the ETOUSA Civil Affairs Section returned to the ETOUSA headquarters. Bendesten studied civil affairs organizations prior to his arrival and made the reorganization of the COSSAC civil affair section his first priority.¹⁷² Within five days of his arrival, the country houses were disbanded, citing the Supreme Commander's "need for a single compact staff that could deal in broad principles."¹⁷³ This allowed civil affairs and military government organizations to "finally achieve integration into the operating military force.... the change was described as being from a static regional approach to a mobile plan. In other words, civil affairs would move with combat troops and be part of the continuing operation, not just a substitute for native government in liberated and occupied areas."¹⁷⁴

Throughout this process the ETOUSA's civil affairs section, remained in operational command of US civil affairs operations in theater. By November of 1943, when it became known that Eisenhower would assume command, the concern for US representation was abated. Even before the conclusion of the Tehran conference, CAD informed Devers that the COSSAC would assume all responsibility for US civil affairs planning.¹⁷⁵ The 1st Army, and later 12th Army headquarters absorbed the ETOUSA CA section.

During the last months of 1943, Morgan and his staff continued to concentrate on RANKIN C. Having solved his organizational problem the focus for planning turned to the means of execution. The concept of splitting Germany into zones had been introduced but the nature of those zones had yet to be decided. The overall scope of territory occupied remained relatively the same, whatever the shape those zones would take. Morgan believed that military government should naturally assist the commander's

¹⁷²In an interview with COSSAC historians, Bendetsen contends that he had been given no direction as to how to organize the civil affairs section. Zimke points out, while this may be true, "it could hardly have been unknown to him that the [CAD] was not happy with the dual command channels AMGOT had created."

¹⁷³Ziemke, 30.

¹⁷⁴Ibid.

¹⁷⁵Ziemke, 31.

ability “to impose his will on the enemy, and the first concern would be to help maintain the striking power of the military force by controlling movements of people and by preventing disease and disorder.”¹⁷⁶

December brought the official announcement Eisenhower as the Supreme Commander, which effectively ended the Morgan’s role as lead planner for operations in Europe. Morgan contributed significantly to the war effort by innovating in organizational structure and enabling commander to plan and execute civil affairs operations.¹⁷⁷ He paved the way for the building of civil affairs schools in England, that trained the civil affairs staff sections and units.¹⁷⁸ Most significantly, the COSSAC published the Standard Policy and Procedures for Combined Civil Affairs Operations in Northwest Europe. This document provided a framework for civil affairs operations integrating British and US policies and civil affairs procedures and “assigned full control of and responsibility for civil affairs and military government to the military commanders, from the Supreme Commander on down.”¹⁷⁹

Return of the AMGOT?

On January 15th 1944, Eisenhower arrived in London, and converted the COSSAC staff into the Supreme Headquarters Allied Expeditionary Force (SHAEF).¹⁸⁰ Several senior staff members involved in the military government planning for Italy also arrived in London, this included Eisenhower’s chief of staff Walter Bedell Smith, who assumed the position of COSSAC. Almost immediately, the former Italian staff took exception to what they perceived as an anti-Mediterranean view of the AMGOT system.¹⁸¹

¹⁷⁶Ibid., 32.

¹⁷⁷Ibid., 33.

¹⁷⁸Ibid.

¹⁷⁹Ibid.

¹⁸⁰Ibid., 42.

¹⁸¹Daugherty and Andrews, 279.

Smith himself remained his European staff that recently arrived from the Mediterranean and “needed to be convinced [the AMGOT] should be abandoned.”¹⁸²

The debate over which system to use at SHAEF continued for several months. At first it seemed as if the AMGOT system would win by default. Smith made several personnel moves, placing several former Italian staff members in the key positions in the civil affairs section. He included the civil affairs section in the general staff organization, and designated it with a G code.¹⁸³ British officer Lumly and his American deputy McSherry led the section known as the G4, responsible for reorganizing the country team sections.¹⁸⁴ Smith also believed a civilian was better suited as the chief of the division. Despite his best attempts, he was unable to make this transition and regulated himself to the role of managing civil affairs.¹⁸⁵

Despite his organizational changes, Smith did not rescind the COSSAC Standard Policy and Procedure document. As a result, army groups were still operated under the principle that they possessed overall responsibility for civil affairs activities in their areas of operation. In fact, Eisenhower already approved the invasion plan of 21 Army Group’s, under General Sir Bernard L. Montgomery. This plan “assumed civil affairs to be an integral function of the tactical commanders from the army group on down.”¹⁸⁶ This, among other factors, ultimately drove Smith to rethink his earlier belief that an AMGOT was the best course of action.¹⁸⁷

¹⁸²Ibid., 279–280.

¹⁸³Military staff sections are separated into functional areas represented by a number (1 = personnel, 2 = intelligence, 3 = operations, etc...). The letter that precedes these numbers represents the level of staff. In this case, the ‘G’ represents the general staff, or a staff that represents a general (e.g. G1, G2, G3, etc...). Lower commands, those not led by a general, have an ‘S’ preceding the number.

¹⁸⁴Daugherty and Andrews, 280.

¹⁸⁵Ziemke, 44.

¹⁸⁶Ibid., 46.

¹⁸⁷Daugherty and Andrews, 280-281. A major contributing factor was British Lieutenant General A. E. Grasett’s appointment as G5. Grasett believed that civil affairs operations are the responsibility of

In the end, Smith decided to abandon the AMGOT in favor of the mobile functional approach.¹⁸⁸ The mobile functional approach gave tactical commanders responsibility for civil affairs operations in their sectors. Field armies and their subordinate headquarters, with assigned civil affairs units to them, were authorized to employ the civil affairs units in support of combat operations. However, while the civil affairs units were employed operationally by the tactical commanders, they maintained a direct “technical” channel of communication between the SHAEF G-5 and the civil affairs section. This technical channel directed civil affairs activities with the purpose of maintaining “...consistency of interpretation and application of policies in each of the countries [concerned]... [through the issuance of] country manuals.... for use of tactical commanders.”¹⁸⁹

the field commander and they should be guided by the amended Handbook on Standard Policy and Procedures for Civil Affairs.

¹⁸⁸ Ziemke, 47. “First, that the Mediterranean organization, although it did a good job, had many defects; and second, that conditions in northwest Europe were different from those in the Mediterranean....civil affairs headquarters would not be established unrelated to military headquarters; and the AMGOT approach would be avoided.”

¹⁸⁹Forrest C. Pogue, *The European Theater of Operations: The Supreme Command* (Washington, DC: Office of the Chief of Military History, 1954), 83; Daugherty and Andrews, 282.

Table 1. US Military Government Relationships (Mobile Phase, Sept 1944-Jul 1945)

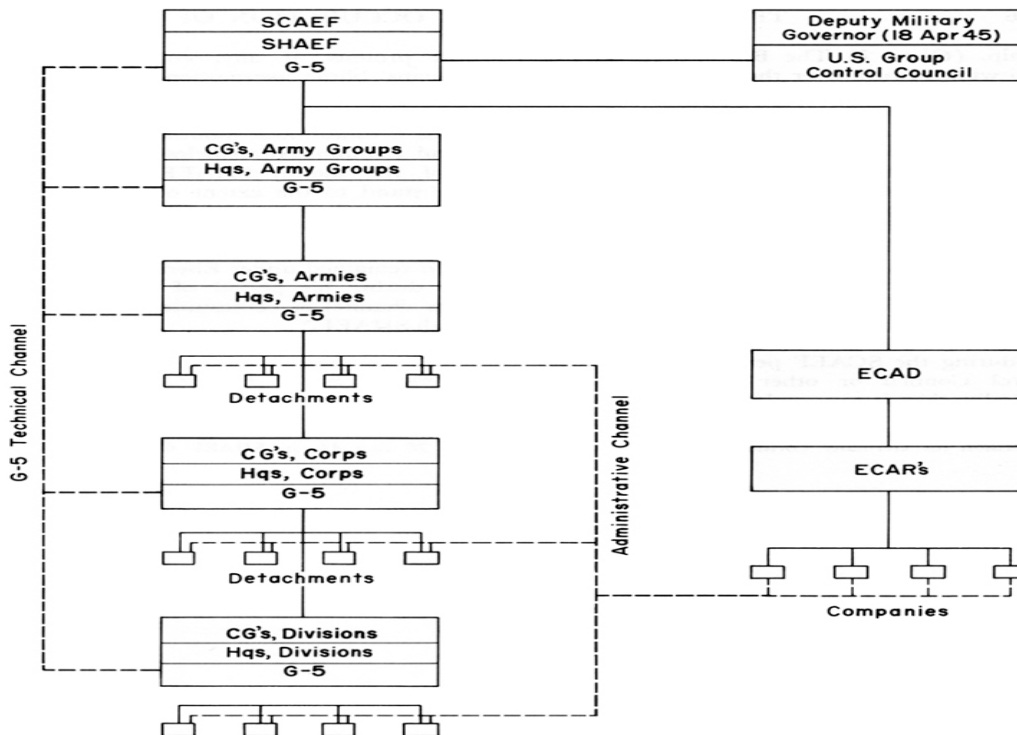

Source: Ziemke, *U.S. Army in the Occupation of Germany, 1944-1946.*, 95.

Organization below SHAEF

In October of 1943, in preparation for Operation OVERLORD, the ETOUSA civil affairs staff transferred to the newly created First US Army Group (FUSAG).¹⁹⁰ The section comprised of eighteen officers, one warrant officer, and twenty-six enlisted, consisted of four branches of administration, operations and personnel, governmental affairs, and economics and supply.¹⁹¹ In September 1944, the

¹⁹⁰In July of 1944 FUSAG was designated 12th Army Group. United States Provost Marshal General's Bureau, "Civil Affairs Handbook, Germany, Section 1: Geographical and Social Background" (16 September 1944).

¹⁹¹Daugherty and Andrews, 283.

headquarters moved to the continent shortly after it expanded to include a public health branch, a plans branch, and a displaced persons branch. Mirroring the SHAEF civil affairs section, the FUSAG civil affairs section was designated as the FUSAG G5.¹⁹² Specialist officers, assigned to the G5, supported over thirty specialty functions and 125 subdivisions of those functions.¹⁹³

Throughout 1944, each of the numbered Army's headquarters organized their own civil affairs sections. First, Third, and Ninth Armies' G5 staff sections consisted of twenty-four officers, one warrant officer, and forty enlisted.¹⁹⁴ Seventh Army, responsible for the invasion of southern and eastern France, had a much smaller section consisting of only four officers and six enlisted. The French civil administration handled civil affairs issues existing in these parts of France. The Seventh Army G5 coordinated with these French administrators to provide aid, supplies, while enabling civilian control in support of military operations.¹⁹⁵

The 12th Army Group provided its corps with a small G5 section consisting of three officers and four enlisted. The infantry and armored divisions possessed small contingent of civil affairs officers and enlisted. For the purposes of Normandy, the First Army attached civil affairs officers to the two airborne divisions.¹⁹⁶ "These officers landed by glider during the initial assault."¹⁹⁷

To man the civil affairs staff sections and create civil affairs detachments, SHAEF drew personnel from the civil affairs school in Shrivenham, England.¹⁹⁸ Graduates were trained and organized

¹⁹²Ibid., 284.

¹⁹³Ibid., 289.

¹⁹⁴Ibid., 284.

¹⁹⁵Ibid., 285.

¹⁹⁶Ibid.

¹⁹⁷Headquarters 12th Army Group, Report of Operations (final After-action Report), Vol. VII, G5 Sec, vol. VII, 1945, 21.

¹⁹⁸Sandler, 189. The US Civil Affairs Center and School in Shrivenham was a combined British and American school activated in February 1944. The purpose of the school was basic military training,

under the European Civil Affairs Division (ECAD). ECAD, comprised of three regiments with eight companies each, provided a total of two hundred operating detachments. These detachments varied from twenty officers and twenty enlisted to four officers and five enlisted.¹⁹⁹ Throughout the war in Europe, the civil affairs regiments were attached to various armies to “administer and supply civil affairs detachments”²⁰⁰ supporting the corps and divisions. As infantry and armor units moved advanced through Europe, “specially selected and trained”²⁰¹ [civil affairs] units moved forward with [them].²⁰²

Planning

At the beginning of November of 1944, the allies landed on the beaches of Normandy and fought to the border of Germany. Up to this point, the policy Morgan requested to govern military government and civil affairs planning had not been provided. Military planners continued to use the FM 27-5 and Country Handbooks written by the CAD.²⁰³ In October of 1944, with the imminent invasion of Germany the CAD directed the Joint Chiefs of Staff to issue JCS 1067.²⁰⁴ The document was “intended as a guide

instruction on the theory and practice of civil affairs and military government, and train a cadre of teams designated for specific regions of a particular country. The basic manual for instruction was the FM 27-5.

¹⁹⁹Daugherty and Andrews, 286.

²⁰⁰Ibid., 286–287.

²⁰¹Sandler, 170. The average civil affairs officer was 43 years old and had only received basic military training, not all were suited duty with front-line units.

²⁰²Daugherty and Andrews, 287.

²⁰³Bureau, “Civil Affairs Handbook, Germany, Section 1.” “The Handbooks do not deal with plans or policies (which will depend upon changing and unpredictable development). It should be clearly understood that they do not imply any given official program of action. They are rather ready reference source books containing the basic factual information needed for planning and policy making.”

²⁰⁴JCS (Joint Chiefs of Staff) wrote 1067 as a compromise born out of discussion (and disagreement) between Secretary of War Stimson, Secretary of State Hull, and Secretary of Treasury Henry Morgenthau, as a proper military directive that addressed five points: the dissolution of the Nazi party; demilitarization; controls over communications, press, propaganda, and education; reparation for those countries wanting it; and decentralization of the German governmental structure. A sixth point to permanently reduce the German standard of living and eliminate the German economic power position in Europe was considered but ultimately dropped. For more information see Ziemke, 97–108.

only for the initial postwar period rather than as an ultimate statement of policy, it was not replaced in full until 1947.”²⁰⁵ November 1944, SHEAF issued the outline plan of Operation ECLIPSE.²⁰⁶

Operation ECLIPSE was defined as the “military continuation of Operation OVERLORD.” Unlike RANKIN C, which assumed a formal German surrender, ECLIPSE called for the forceful entry into Germany,²⁰⁷ commencing when Germany surrendered or “when a major portion of the GERMAN forces opposing [the Allies] capitulated or...overpowered.”²⁰⁸ Therefore, the decision to execute ECLIPSE, in absence of formal surrender, was based on Eisenhower’s estimation of German resistance. In other words, “a decision will be taken by the Supreme Commander as; to when 'OVERLORD' gives place to 'ECLIPSE'.”²⁰⁹

ECLIPSE was a two-phase operation. The primary phase began with the surrender or collapse of Germany, seen as the “consummation of OVERLORD,” and called for the rapid advance to strategic locations within Germany.²¹⁰ The second phase called for forces to secure second tier strategic objectives

²⁰⁵Lucius D. Clay, *Decision in Germany* (Greenwood Press, 1970), 17.

²⁰⁶Ziemke, 163. Operation ECLIPSE, originally named Operational TALISMAN in August 1944, was renamed due to an intelligence breach, and succeeded RANKIN C.

²⁰⁷*Ibid.*

²⁰⁸Headquarters Seventh Army, “Planning Directive, Operation ‘ECLIPSE’”, 1945.

²⁰⁹Supreme Headquarters Allied Expeditionary Forces, “ECLIPSE Appreciation and Outline Plan,” 1944, 1, <http://cgsc.contentdm.oclc.org/utills/getfile/collection/p4013coll8/id/2948/filename/2937.pdf>. The objectives of operation ECLIPSE were as follows: BERLIN. To gain control over the enemy's capital and foremost administrative and transportation centre) to secure important intelligence targets and information centres and installations; and to display our armed strength. HAMBURG-KIEL area. To gain control over the " German naval organization to secure an important port and industrial area, and to isolate German forces in NORWAY and DENMARK.' WUREIFFLURG-REGENSBURG-MUNICH area. To gain control of the main administrative centres of Southern.GERMANY) and to secure the main communications from the SOUTH, thereby isolating enemy forces in ITALY, AUSTRIA and the BALKANS (This objective is of lower priority than the above.)

²¹⁰*Ibid.*, 5.

and to “proceed to establish law and order and to control frontiers through the Supreme commander’s sphere of responsibility and later to withdraw into their respective national areas of occupation”²¹¹

During the second phase, ECLIPSE had five objectives: primary disarmament and control of German forces; enforcement of the terms of surrender or the will of SHEAF in the event there was no surrender; establishment of law and order; beginning of the total disarmament of Germany; and redistribution of Allied forces into their national zones.²¹² The second phase was less of a military operation but rather an “administrative plan for establishing the occupation of Germany.”²¹³

A “considerable number of functional guides...and other statements of administrative policies and procedures that grew up around, and in supplement to, the ECLIPSE Plan constituted collectively the standing operating procedures of the occupation force.”²¹⁴ It provided practical guidance to subordinate commanders and staff alike. The ECLIPSE plan included annexes with full staff assessments from across the headquarters, intelligence, logistics, and engineer, and identified the need to create new organizations like the Information Control Units (ICU).²¹⁵

Perhaps the most surprising element of Operation ECLIPSE is how it was implemented. Instead of executing ECLIPSE after OVERLORD, it actually became a plan executed simultaneously OVERLORD. On September 12th 1944, elements of the First Army’s VII Corps crossed the border of Germany and occupied the village of Roetgen. Civil Affairs detachment D8B1, integrated with VII Corps forces, posted the Supreme Commander’s proclamation and ordinances, which officially declared to the

²¹¹Ibid.

²¹²Ibid., 7.

²¹³Ziemke, 163.

²¹⁴United States Army, European Command, Historic Division, *Planning for the Occupation* (Frankfurt, Germany: Office of the Chief Historian, European Command, Occupation Forces in Europe Series, 1945-1946, 1947), 112.

²¹⁵Kenneth McCreedy, “Planning the Peace: Operation Eclipse and the Occupation of Germany” (Monograph, School of Advanced Military Studies, 1995), 26.

citizens of Roetgen that they were under the control of the Allied military government.²¹⁶ The Allied occupation experience with began during the war.

Execution

As German forces were defeated, and allied forces occupied German territory, detachments like D8B1²¹⁷ entered the surrounding towns and villages, and immediately announced the occupation²¹⁸ by posting “Notice to the Population.” Following a model similar to Italy, the civil affairs detachments exercised indirect control of the population, by locating the mayor, or appointing one if he could not be found or was “obviously a Nazi.”²¹⁹ After establishing control, a series of deliberate actions established security. They directed citizens to surrender all weapons, ammunition, explosives, and communications conducted house-to-house searches to ensure compliance.²²⁰

The method for establishing control over the population depended on the tactical commander’s preference, and often included evacuation or a curfew in place.²²¹ The key to any method of civilian control was the registry of all adults.²²² Detachments established local police forces and military government courts to enforce the rules of the occupation which included, general, intermediate and

²¹⁶Ziemke, 133–134.

²¹⁷Daugherty and Andrews, *A Review of US Historical Experience with Civil Affairs*, 545. Civil affairs detachments received alphanumeric designators. The first letter A-I or a specialty code (ex. HQ) represented what type of detachment they were. ‘D’ detachments were the smallest detachment numbering 9 men and were most often the detachment operating with combat troops. The second alphanumeric distinguished one detachment from another.

²¹⁸Ziemke, *U.S. Army in the Occupation of Germany, 1944-1946*, 134.

²¹⁹Ziemke, 134.

²²⁰*Ibid.*, 134–135.

²²¹*Ibid.*, 136. “12th Army Group did not have a uniform policy.” Initially the commander preferred to remove civilians from the battlefield. In October, V corps attempted such an evacuation and found the required logistics and security too difficult. The experience taught the commanders that the best method of establishing control was to keep civilians in place.

²²²Ziemke, *U.S. Army in the Occupation of Germany, 1944-1946.*, 135–136.

summary courts.²²³ The officers of the detachments acted as judge, prosecutor, and defense for the courts.²²⁴

The most common challenges facing commanders and their military government detachments resembled those in Africa and Italy. Detachments contended with issues of displaced persons, labor procurement in support of military activities, and the restoration of public utilities as part of public health.²²⁵ The denazification program, like the anti-fascism program, was difficult to implement at the local levels. Commanders frequently faced the difficult task of selecting administrative experts that were not Nazis, and forced to choose based on “political character to administrative efficiency.”²²⁶

Civil Affairs Detachments were not immune to the chaos of war. On December 16th, in what was called the Battle of the Bulge, the Germans attacked through the Ardennes Forest into the V and VIII and Corps flank. In response to the Germans attack, six military government detachments deployed in Germany escaped to France. Detachment I8G2 fought its way out with the 14th Cavalry Group. Detachment D6G1 was overrun and captured. Detachment I4G2, despite having permission to leave, remained at their post in the town of Monschau.²²⁷

As tactical units progressed further into Germany, the pool of available Civil Affairs officers dwindled. The short-term fix was to use Detachments trained to assume control of later Bavarian objectives, would temporally assume control of the immediate objectives like Hanover. Later, when it

²²³Sandler, 204.

²²⁴Daugherty and Andrews, 299.

²²⁵Ibid., 290–293.

²²⁶HQ 12th Army Group, memo, “Government Affairs in Area Stolberg, Kornelimunster’ Breinig, 2 October 1944.” SHAEF G-5, Information Branch, Historic section, RG 331, entry 54, folder 204; 12th Army Group, “Civil Affairs and Military Government Summary No. 262, 23 February 1945, 12 AG-G-5, RG 407, entry 427, box 1780, folder 99-12.5-0

²²⁷Ziemke, 154. The detachment decided against leaving because it believed its presence could assist the tactical unit, its departure would prove demoralizing to the German population (for fear of Nazi reprisal) and hinder future military government operations. During the battle, with the help of the local population, the detachment captured twenty-five German paratroopers.

became necessary to use the Bavarian trained detachments for Bavaria, 21st Army Group back filled 12th Army Group with British detachments.²²⁸

Interestingly, the 12th Army Group and its subordinates did not wait for help and took measures to mitigate the deficit, having foreseen the shortage of military government detachments. On April 3rd 1945, “12th Army Group authorized its three armies to mobilize, from tactical troops, provisional military government detachments.”²²⁹ Soldiers and officers came from antiaircraft artillery, field artillery, and signal personnel to meet detachment requirements.²³⁰

On Victory in Europe day (VE-day) the total US military government strength in the European Theater of Operations was 28,840 officers, 193 warrant officers, and 6,398 enlisted men.²³¹ This number does not include a number of United Nations civilians and Ally liaison officers attached to the US military. These individuals integrated with the tactical combat commands and facilitated the defeat of Germany. They supported tactical commanders in various capacities, including clearing lines of communication of civilian congestion, facilitating secure areas to the rear of tactical troops, and securing white lining used as make shift snow suits.²³² Above all, despite the necessary ad hoc nature of employment “these relatively small forces successfully established control over an estimated 80,000,000 people, roughly half of whom were of enemy nationalities.”²³³

Lessons Learned

The SHAEF G5 conducted a field survey of civil affairs operations during the Rhineland campaign. It concluded the “theory of tactical military government” might be untenable due to the sure

²²⁸Daugherty and Andrews, 294.

²²⁹Ibid.

²³⁰Sandler, 208.

²³¹Daugherty and Andrews, 544.

²³²Ibid., 296–298.

²³³12th AG After-Action Report, op. cit, Vol. VII, 22.

size of the area of operation.²³⁴ According to the survey “arbitrary unit boundaries, sometimes dividing cities in two,”²³⁵ which resulted in multiple commanders being responsible for a single population center? Detachment commanders were “simultaneously taking orders from platoon commanders and army headquarters or any staff in between.”²³⁶ Some civil affairs functions, such as agriculture and food distribution, “were too broad for the armies to control.”²³⁷

The survey also found a “deficiency in political guidance,” citing that the policy was clearly aimed to destroy Nazism, but did not articulate what to put in its place.²³⁸ When discussing military government lessons learned in the Northwest European Theater, Daugherty and Andrews’s wrote, “operations are greatly handicapped by lack of policy guidance....”²³⁹ and the lack of an “interdepartmental agency (to resolve policy conflicts) accentuated the handicaps.”²⁴⁰

Beyond policy, Daugherty and Andrews addressed the vital role civil affairs personnel played during World War II, because having relieved troop commanders of much of the burden inherent to civil affairs. Civil affairs personnel possessed the required varying skills, aptitude and knowledge; however the need far surpassed the estimated numbers of personnel. For them, military government was most effective when controlled through technical channels verses tactical channels. However, to address this issue, “it is not sufficient for the military to simply rid itself of the burden of administration.”²⁴¹ The Army remained

²³⁴Ziemke, 206.

²³⁵Ibid.

²³⁶Ibid.

²³⁷Ibid.

²³⁸Ibid., 206–207.

²³⁹Daugherty and Andrews, 314.

²⁴⁰Ibid.

²⁴¹Ibid.

in control of the military government for four years. “Thus, as in times past, the Army remained in overall control of the administration...in a defeated country far longer than any of its leaders desired.”²⁴²

CONCLUSION

The execution of ULO by way of decisive action provides the necessary framework to drive commanders to plan offensive and stability operations simultaneously. However, offense and stability are not necessarily complimentary in nature, and require a different data set to begin planning. Offensive operations rely on an assigned military objective, while stability operations require policy for a desired future. The lack of political guidance and policy given to military leaders to govern civil affairs activities is an enduring criticism, to include Iraq and Afghanistan.²⁴³ However, as discussed, a lack of policy is not a sufficient reason to delay stability operations planning. Commanders and planners must be prepared to plan and execute stability operations despite a lack of clear political guidance.

When faced with situations like Syria and Libya, one cannot dismiss the potential for the United States to use its military power for the purposes of regime change, similar to Iraq and Afghanistan.²⁴⁴ If called upon to conduct such an operation, the Army will utilize its ULO doctrine, which calls for the simultaneous execution of offensive and stability operations.

The experience of World War II also provides commanders and planners a model for simultaneous execution of offense and stability for future operations against failing and failed states. It demonstrates how the construct of simultaneity enables more effective offensive operations. While ULO has yet to be used in a major operation, the Allies’ experience in World War II provides evidence that, when planned and resourced appropriately, offensive and stability operations can be conducted continuously and simultaneously, setting the conditions for a military and political victory.

²⁴²Ibid.

²⁴³JCOA, *Decade of War*, 15.

²⁴⁴Christopher M. Blanchard and Jeremy M. Sharp, *Possible U.S. Intervention in Syria: Issues for Congress* (Washington, DC: Congressional Research Service, 12 September 2013), 1-49.

This monograph focused on the organization, planning, and employment of civil affairs capabilities during combat. The key to decisive action is the simultaneous execution of offense, defense and stability operations. During World War II, by employing a force of specially trained civil affairs personnel simultaneously alleviate tactical forces of the burden of civil affairs operations. Despite the number of trained civil affairs personnel provided, the supply did not meet the demand, requiring in the utilization of combat troops to fill the gaps. To complicate the issue, little doctrine existed to inform how to integrate civil affairs operations with combat operations. As a result, the United States entered the war without a clear understanding the military's role in civil affairs and military governance.

By 1945, through trial and error, most of these shortfalls had been addressed. To effectively conduct civil affairs and combat operations, the military required separate forces for each. Combat forces could be used when such personnel were not available, while it was preferred to have special trained personnel to execute civil affairs and military government operations. Civilian agencies did not have a robust enough expeditionary capability to execute such operations without significant military support; therefore, civil affairs and military governance became the responsibility of the military chain of command during combat operations. The doctrine that governed civil affairs and military government operations addressed not only the military aspects of civil affairs and military governance but established the actual policy as well.

The invasion of Sicily demonstrated the negative impact of failing to integrate civil affairs operations into combat operations. In order for civil affairs operations to effectively support combat operations, they must be planned in concert. Lack of specific policy is not a sufficient reason to delay civil affairs planning, military commanders need to make policy decisions based on the military situation. Such decisions must always be made with an eye towards the desired political end state. This requires clear and honest dialogue between military and political leadership.

World War II provides two examples of how to employ civil affairs forces, both of which presented with opportunities and limitations. In Italy, civil affairs units belonged to a separate army, and

were employed in a supporting role to combat operations. This ensured the uniform application of policy, but sacrificed the tactical unity of command desired by the army's commanders. In Germany, civil affairs units were assigned directly to tactical commanders, increasing their responsiveness to, and coordination with, combat operations but affected the uniform application of policy, negatively impacting the occupation phase. The analysis does not identify one method as being better than the other. It identifies the need for technical and tactical methods of controlling civil affairs activities

Recommendations

The civil affairs operation conducted during World War II is a successful example for executing an occupation of a country, belligerent or otherwise. Eisenhower understood the necessity for a separate civil affairs force, organized, trained, and integrated with combat forces prior to the commencement of operations. He understood the importance of unity of command for both the civil affairs and combat forces during military operations. These are the major lessons borne through historical experience and trial and error during the war. Contemporary doctrine does not fully encapsulate the lessons of World War II.

As previously discussed, the concept of ULO provides military commanders with functional guidelines for conducting stability and offensive operations. Stability doctrine goes into great depth describing the lines of operations that must be considered as part of stability operations. Where today's doctrine is deficient is its continuous exertion that stability is the responsibility of others, be it the Department of State, United Nations, or host-nation government. Historical evidence has demonstrated that a dependency on external agencies for stability operations increases risk to the successful achievement of military and political objectives. There is evidence that indicates that this trend is as relevant today as it was during World War II.²⁴⁵

²⁴⁵Robert Hoekstra and Charles E. Tucker JR., "Adjusting to Stabilization and Reconstruction Operations," *PRISM*, March 2010. In December of 2005 President George W. Bush issued National

To address this doctrinal gap, the military needs to revise its doctrine to specifically address the military's role in stability operations and the requirement for a designated stability force. When faced with military objectives that include the establishment interim government, military or civilian, there must be a clear understanding of who is responsible for that interim organization. Once identified, the stability force responsible for occupation must be formed and capable, operationally and logistically, as well as fully integrated into the combat operation, prior to the start of those operations. Granted, this recommendation becomes more difficult in a fiscally conservative environment coupled with recent examples of military success using small military forces to achieve a quick decisive victory. However, in terms of establishing interim governance, failure to address these concerns is a return to the pre-World War II ad hoc nature of stability operations and creates inherent risk to mission success.

Security Presidential Directive-44 in an effort to bolster the State Department's expeditionary capability for stability operations in conjunction with military operations. The author provides evidence that indicates that the effort has fallen short. Because of this, he recommends that the military build capacity to ensure the State Department has input into future stability operations.

BIBLIOGRAPHY

Primary Sources

- Bureau, United States Provost Marshal General's. "Civil Affairs Handbook, Germany, Section 1: Geographical and Social Background" (September 16, 1944).
- Clay, Lucius D. *Decision in Germany*. Greenwood Press, 1970.
- Benson, Kevin C.M. "OIF Phase IV: A Planner's Reply to Brigadier Aylwin-Foster." *Military Review*, no. March-April 2006 (March 2006). <http://cgsc.contentdm.oclc.org/utills/getfile/collection/p124201coll1/id/35/filename/36.pdf>. (accessed February 8, 2014)
- Headquarters 12th Army Group. Report of Operations (final After-action Report), Vol. VII, G5 Sec. Vol. VII, 1945.
- Headquarters, Department of the Army. Army Doctrine Publication (ADP) 1, *The Army*, Washington, DC: Government Printing Office, 2013.
- . Army Doctrine Publication (ADP) 3-0, *Unified Land Operations*. Washington, DC: Government Printing Office, 2011.
- . Army Doctrine Reference Publication (ADRP) 3-0, *Unified Land Operations*. Washington, DC: Government Printing Office, 2012.
- . Army Doctrine Publication (ADP) 3-07, *Stability*, Washington, DC: Government Printing Office, 2012.
- . Army Techniques Publication (ATP) 3-07.5, *Stability Techniques*. Washington, DC: Government Printing Office, 2012.
- . Field Manual (FM) 1, *The Army*, 2005. <http://www.army.mil/fm1/chapter1.html#section7>.
- Headquarters Seventh Army. "Planning Directive, Operation 'ECLIPSE'", 1945.
- Joint Forces Command. *Handbook for Military Support to Governance, Elections, and Media: Unified Action Handbook Series Book Three*. Joint Concept Development and Experimentation Directorate and Doctrine and Education Group, JWC, 2010. Accessed March 19, 2014. http://www.dtic.mil/doctrine/doctrine/jwfc/gem_hbk.pdf.
- Joint Forces Command. Joint Publication (JP) 3-0, *Joint Operations*, Washington, DC: Government Printing Office, 2011.
- . Joint Publication (JP) 3-07, *Stability Operations*, Washington, DC: Government Printing Office, 2011.

Supreme Headquarters Allied Expeditionary Forces. "ECLIPSE Appreciation and Outline Plan", 1944. <http://cgsc.contentdm.oclc.org/utills/getfile/collection/p4013coll8/id/2948/filename/2937.pdf>.

United States War Department. *The War of the Rebellion: A Compilation of the Official Records of the Union and Confederate Armies*, vol. 3. III. Washington, DC: Government Printing Office, 1899. <http://ehistory.osu.edu/osu/sources/recordView.cfm?page=148&dir=124> (accessed 10 February 2014).

United States Army Doctrine Proponent. "Doctrine Update, 1-12". Combined Arms Center, December 16, 2011. http://usacac.army.mil/cac2/adp/Repository/Army%20Doctrine%20Update%201-12_16%20Dec%202011.pdf. (accessed 9 February 2014).

Secondary Sources

Bauer, Karl Jack. *The Mexican War, 1846-1848*. University of Nebraska Press, 1992.

Brocades Zaalberg, Thijs. *Soldiers and Civil Power: Supporting or Substituting Civil Authorities in Modern Peace Operations*. Amsterdam, NE: Amsterdam University Press, 2006.

Coles, Harry L., and Albert K. Weinberg. *Civil Affairs: Soldiers Become Governors*. CMH Pub 11-5 edition. Washington, DC: Center of Military History Department of the Army, 1964.

D'Este, Carlo. *Decision in Normandy*. New York: Konecky & Konecky, 1994.

Daugherty, William E., and Marshall Andrews. *A Review of US Historical Experience with Civil Affairs: 1776 - 1954*. Johns Hopkins University: Operations Research Office, 1961.

Guttieri, Karen Rochelle. "Toward a Usable Peace : United States Civil Affairs in Post-conflict Environments" (1999). <https://circle.ubc.ca/handle/2429/9989> (accessed 26 January 2014).

Fallows, James. "Blind Into Baghdad." *The Atlantic*, January 2004. <http://www.theatlantic.com/magazine/archive/2004/01/blind-into-baghdad/302860/> (accessed 19 January 2014).

Harris, Charles Reginald Schiller. *Allied Military Administration of Italy, 1943-1945*. London: H.M. Stationery Office, 1957.

Hickman, Kennedy. "World War II: The Postwar World, Ending the Conflict." *About.com Military History*, n.d. <http://militaryhistory.about.com/od/worldwarii/a/wwiipost.htm> (accessed 20 February 2014).

Hicks, Kathleen, and Christine Wormuth. *The Future of U.S. Civil Affairs Forces*. Center for Strategic & International Studies, February 2009.

Hoekstra, Robert, and Charles E. Tucker JR. "Adjusting to Stabilization and Reconstruction Operations." *PRISM*, March 2010.

JCOA. *Decade of War, Volume I: Enduring Lessons from the Past Decade of Operations*. Joint and Coalition Operational Analysis, June 15, 2012.

- Johnson, Timothy D. *A Gallant Little Army: The Mexico City Campaign*. Modern war studies. Lawrence, Kan: University Press of Kansas, 2007.
- Leighton, Richard M. *United States in World War II- The War Department-Global Logistics and Strategy 1940-1943*. Washington, DC: Center of Military History, 1955.
- McCreeedy, Kenneth. "Planning the Peace: Operation Eclipse and the Occupation of Germany." Monograph, Command and General Staff College, 1995.
- Melton, Stephen L. *The Clausewitz Delusion: How the American Army Screwed Up the Wars in Iraq and Afghanistan (A Way Forward)*. Minneapolis, MN: Zenith Press, 2009
- Morgan, Sir Fredrick Edgworth. *Overture to Overlord*. Garden City, NY: Doubleday, 1950.
- Oehrig, Cristen. *Civil Affairs in World War II*. Center for Strategic & International Studies, January 28, 2009. csis.org/publication/civil-affairs-world-war-ii (accessed 13 August 2013).
- Pogue, Forrest C. *The European Theater of Operations: The Supreme Command*. Washington, DC: Office of the Chief of Military History, 1954.
- Sandler, Stanley. *Glad to See Them Come and Sorry to See Them Go*. Washington, DC: Government Printing Office, 2004.
- United States Army, European Command, Historic Division. *Planning for the Occupation*. Frankfurt, Germany: Office of the Chief Historian, European Command, Occupation Forces in Europe Series, 1945-1946., 1947.
- Witt, John Fabian. *Lincoln's Code: The Laws of War in American History*. New York: Free Press, 2012.
- Ziemke, Earl F. *U.S. Army in the Occupation of Germany, 1944-1946*. Washington, DC: Office of the Chief of Military History, Department of the Army, 1975.

Tertiary Sources

- Blanchard, Christopher M., and Jeremy M. Sharp. *Possible U.S. Intervention in Syria: Issues for Congress*. Washington, DC: Congressional Research Service, 12 September 2013.
- Gaddis, John Lewis. *The Landscape of History: How Historians Map the Past*. Oxford; New York: Oxford University Press, 2004.
- Gerhard, Spc. Zechariah. *PRT Legacy Documentary*. Iraq, 2011.
<http://www.dvidshub.net/video/123685/prt-legacy-documentary#.Uvu7Xf2QIzk> (accessed 12 February 2014).
- Schlosser, Nicholas J. "The Marine Corps' Small Wars Manual: An Old Solution to a New Challenge?" *Fortitudine* 35, no. 1 (2010): 4-9.