



TECHNICAL DOCUMENT 3282
August 2014

Electrode Placement for Active Tuning of Silicon-on-Insulator (SOI) Ring Resonator Structures Clad in Nematic Liquid Crystals

Joanna Ptasinski

Approved for public release.

SSC Pacific
San Diego, CA 92152-5001

TECHNICAL DOCUMENT 3282
August 2014

Electrode Placement for Active Tuning of Silicon-on-Insulator (SOI) Ring Resonator Structures Clad in Nematic Liquid Crystals

Joanna Ptasinski

Approved for public release.

SSC Pacific
San Diego, CA 92152-5001



SSC Pacific
San Diego, California 92152-5001

K. J. Rothenhaus, CAPT, USN
Commanding Officer

C. A. Keeney
Executive Director

ADMINISTRATIVE INFORMATION

This report was prepared by the Advanced Photonics Technologies Branch (Code 55360), SPAWAR Systems Center Pacific (SSC Pacific), San Diego, CA. The project work is funded by the Naval Innovative Science and Engineering Program at SSC Pacific. The project category is Basic Research.

Released by
R. Clement, Acting Head
Advanced Photonics
Technologies Branch

Under authority of
C. Hendrickson, Head
Enterprise Communications
and Networks Division

This is a work of the United States Government and therefore is not copyrighted. This work may be copied and disseminated without restriction.

The citation of trade names and names of manufacturers in this report is not to be construed as official government endorsement or approval of commercial products or services referenced in this report.

COMSOL[®] and COMSOL Multiphysics[®] are registered trademarks of COMSOL AB.
LIXON[™] is a trademark of JNC Corporation.

EXECUTIVE SUMMARY

OBJECTIVE

This technical report analyzes the optimum electrode placement for electrically tunable ring resonators. Combining these resonators with nematic liquid crystals enables easily tunable devices where the tuning is performed through either electrical or optical means. Electrode placement determines the total amount of a resonance shift that can be achieved.

METHOD

Simulation results contained within this report were performed using COMSOL Multiphysics® for a 500-nm wide, 250-nm tall silicon waveguide surrounded by SiO₂ and liquid crystals. The 500-nm wide waveguide confines most of the optical mode to its core.

CONCLUSIONS AND RECOMMENDATIONS

The effect of electrode placement for electrically tunable ring resonators was analyzed. The symmetric ring resonator geometry plays a role in the total amount of achievable resonance shift. Factors governing the overall amount of resonance shift include the perimeter of the ring, the amount of the ring covered by SiO₂, and the waveguide propagation loss influenced by the location of the metal layer above the buried oxide (BOX).

CONTENTS

EXECUTIVE SUMMARY	III
1. INTRODUCTION	1
2. ELECTRODE PLACEMENT FOR ACTIVE TUNING OF LIQUID CRYSTALS.....	1
3. CONCLUSIONS.....	9
4. REFERENCES.....	9

Figures

1. A schematic illustrates why the ring symmetry requires a break.....	1
2. Conceptual schematic of electrode placement for active electrical tuning of liquid crystals	2
3. (A) Conceptual diagram of the placement of the metal layer above the silicon waveguide. (B) COMSOL [®] simulation of the TM mode for a 500 nm wide, 250 nm tall silicon waveguide surrounded by SiO ₂ and with a metal electrode placed 100 nm above the silicon waveguide	3
4. The electrodes are placed 0.7 μm above the BOX layer and a fifth of the ring is covered by SiO ₂ . The Si ring and the bus waveguides are both 250 nm tall (depicted in gray)	4
5. Simulation showing the electric field x-component when a potential is applied to the electrodes	4
6. Electric field x-component for a 30-V applied potential and a fifth of the ring covered by SiO ₂	5
7. Electric field x-component for a 38-V applied potential and a fifth of the ring covered by SiO ₂	5
8. Electric field x-component for a 45-V applied potential and a fifth of the ring covered by SiO ₂	6
9. Electric field x-component and resonant peak tuning as a function of applied potential when a fifth of the ring is covered by SiO ₂	6
10. The electrodes are placed 0.65 μm above the BOX layer and one-half of the ring is covered by SiO ₂ . The Si ring and the bus waveguides are both 250 nm tall (depicted in gray)	7
11. Electric field x-component for a 25-V applied potential and one-half of the ring covered by SiO ₂	7
12. Electric field x-component for a 38-V applied potential and one-half of the ring covered by SiO ₂	8
13. Resonant peak tuning as a function of applied potential when one-half of the ring is covered by SiO ₂	8

Table

1. Losses for a 500-nm wide, 250-nm tall silicon waveguide surrounded by SiO ₂ and with a metal electrode placed a distance above the waveguide.....	3
---	---

1. INTRODUCTION

Tunable photonic resonant structures allow for altering of their electromagnetic spectrum and find applications in optical switching, filtering, buffering, lasers, and biosensors. Photonic resonances are essentially optical modes that require strong photon confinement that can be achieved through high index contrast using either dielectric materials or metals (plasmonics). Examples of dielectric resonators include rings, racetracks, disks, waveguide grating resonators, and contra directional grating coupler ring resonators [1–3]. Combining dielectric resonators with nematic liquid crystals (LC) enables easily tunable devices where the tuning is performed through either electrical or optical means [4]. Analyzing the optimum electrode placement for electrically tunable ring resonators is of interest because the device geometry plays a role in the total amount of a resonance shift that can be achieved.

2. ELECTRODE PLACEMENT FOR ACTIVE TUNING OF LIQUID CRYSTALS

The symmetric ring resonator geometry becomes an important factor in the active tuning of liquid crystals, and to observe an appreciable resonance shift, the ring symmetry must be broken; otherwise, the effective index changes stemming from the contributions of the two LC orientations may cancel each other, resulting in a null shift of the resonance [5]. Figure 1 shows a schematic that illustrates this concept.

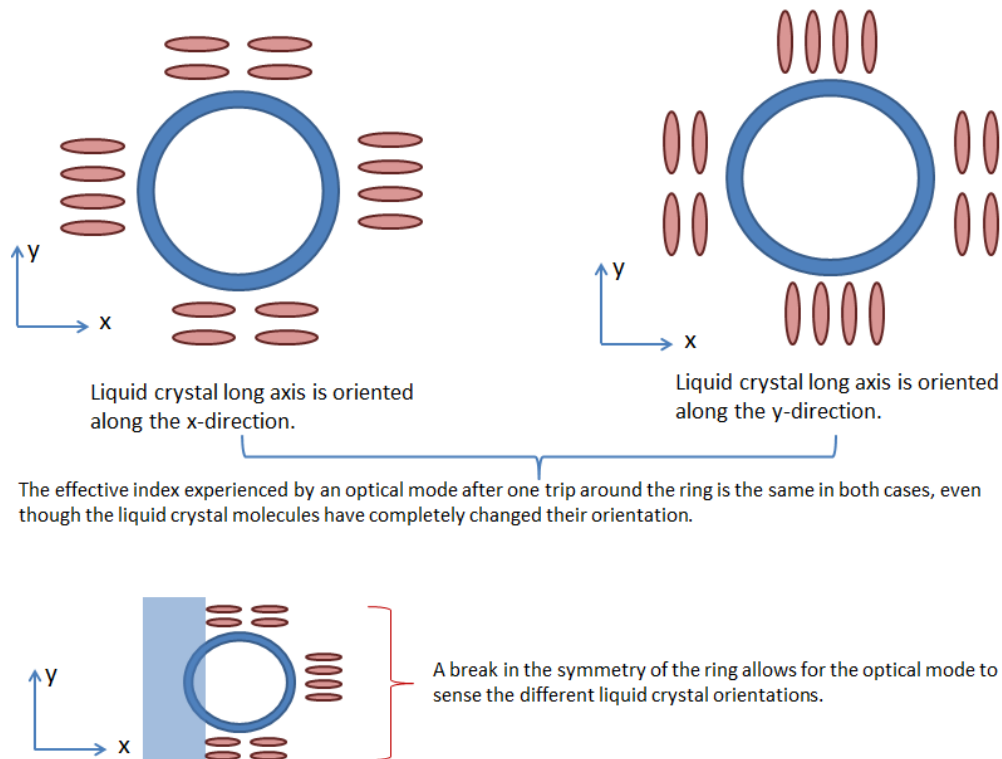

Figure 1. A schematic illustrates why the ring symmetry requires a break.

Additional factors contributing to the overall amount of resonance shift include the perimeter of the ring and specific placement of the electrodes. To simultaneously break the geometry of the ring and also embed electrodes with minimal obstacles to fabrication, a scheme where the electrodes are raised above the silicon structures is preferred. Figure 2 shows a conceptual schematic of the scheme. This configuration relies on tuning of the LC layer by fringe fields formed between the electrodes. The distance between the electrodes and the height of the electrodes above the buried oxide layer impact the strength of the field near the silicon structures. The maximum amount of the refractive index change due to LC tuning is affected by how much of the ring is covered by the SiO₂ layer affects the maximum amount of the refractive change caused by LC tuning, and the location of the metal layer above the buried oxide (BOX) influences the waveguide propagation loss.

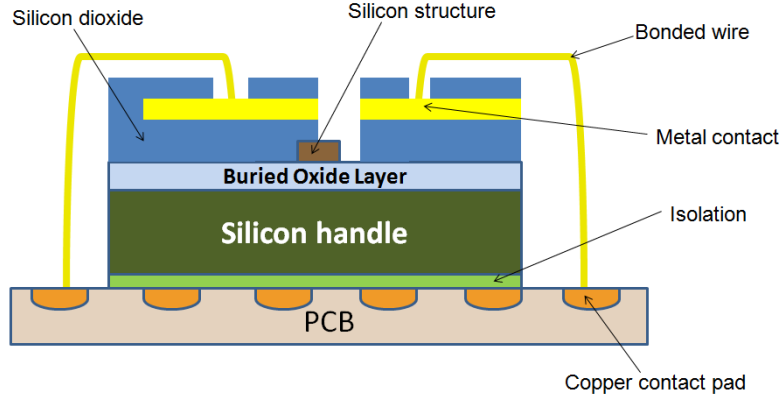

Figure 2. Conceptual schematic of electrode placement for active electrical tuning of liquid crystals.

Figure 3 (A) shows a schematic of a metal electrode layer placed above a silicon waveguide. Figure 3 (B) depicts the result of a COMSOL[®] simulation of the transverse magnetic (TM) mode for a 500-nm wide, 250-nm tall silicon waveguide surrounded by SiO₂, and with a gold electrode placed 100 nm above the silicon waveguide. A large portion of the optical mode is confined to the silicon waveguide, but a fraction of the mode is also confined to the SiO₂ region between the silicon waveguide and the metal electrode. A cavity forms between the two high index regions of Si and Au.

In Table 1, the transverse electric (TE) and TM mode effective indices of a 500-nm wide, 250-nm tall silicon waveguide are shown as a function of the location of the metal layer. Losses are minimized as the metal layer is placed further away from the silicon structure and, as expected, the TM mode loss is greater than that of the TE mode, due to the TM mode electric field vector pointing in the direction of the electrode.

The signal loss over a distance, z , is calculated using the Beer–Lambert law:

$$I(z) = I_0 \exp(-\alpha z), \quad (1)$$

where α is the attenuation coefficient expressed as

$$\alpha = 2k_0 k, \quad (2)$$

and $k_0 = 2\pi / \lambda_0$, where λ_0 is the wavelength. The absorption index, k , can be obtained from the complex refractive index, $N = n + ik$.

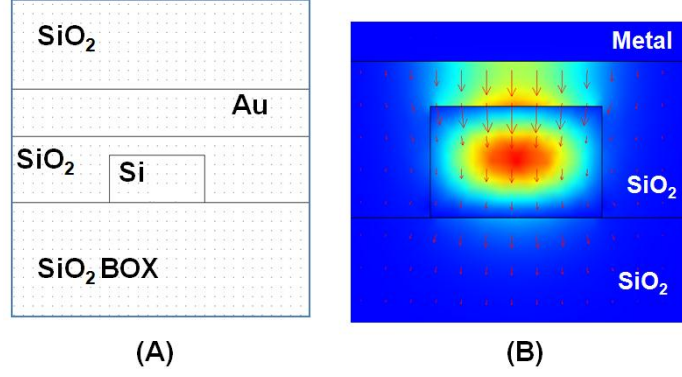

Figure 3. (A) Conceptual diagram of the placement of the metal layer above the silicon waveguide. (B) COMSOL[®] simulation of the TM mode for a 500-nm wide, 250-nm tall silicon waveguide surrounded by SiO₂ and with a metal electrode placed 100 nm above the silicon waveguide.

Table 1. Losses for a 500-nm wide, 250-nm tall silicon waveguide surrounded by SiO₂ and with a metal electrode placed a distance above the waveguide.

Effective Indices		
No metal	TE $n_{eff} = 2.5720$	TM $n_{eff} = 2.064 - 2.509e-10i$
Metal 400nm above BOX	TE $n_{eff} = 2.51-8.31e-4i$	TM $n_{eff} = 2.13 - 1.756e-3i$
Metal 450nm above BOX	TE $n_{eff} = 2.541-1.236e-4i$	TM $n_{eff} = 2.026-5.362e-4i$
Metal 500nm above BOX	TE $n_{eff} = 2.545-4.875e-5i$	TM $n_{eff} = 2.008-3.04e-4i$
Metal 550nm above BOX	TE $n_{eff} = 2.546-1.95e-5i$	TM $n_{eff} = 2.0-1.72e-4i$
Metal 600nm above BOX	TE $n_{eff} = 2.547-7.84e-6i$	TM $n_{eff} = 1.99-9.69e-5i$
Metal 650nm above BOX	TE $n_{eff} = 2.547-3.1e-6i$	TM $n_{eff} = 1.99-5.385e-5i$
Metal 700nm above BOX	TE $n_{eff} = 2.547-1.35e-6i$	TM $n_{eff} = 1.99-3.11e-5i$

The tradeoff between electrode placement and the field required for LC tuning is investigated below using the LIXON[™] ZSM-5970 LC mixture. At 1550 nm, the LIXON[™] indices are $n_o = 1.473$ and $n_e = 1.573$, and its threshold voltage is $V_t = 1.61V$, and saturation voltage $V_{sat} = 2.51 V$. LIXON's clearing point temperature is 123 °C.

Figure 4 depicts a model where the electrodes are placed 0.7 μm above the BOX layer and the SiO₂ layer covers a fifth of the ring. The bus waveguides are spaced 100 nm from the ring. In this model, the potential is varied between 30 to 53 V. Figure 5 shows the strength of the electric field (x-component) for an applied potential of 30 V. The figure shows that field is the strongest near the electrodes.

At 30-V potential, the fringe field allows for LC realignment near the edge of the electrodes. The E-field for most of sample, at a height of 125 nm above the BOX, is 1.43 V/ μm (below the LC threshold voltage) as shown in Figure 6. The strength of the E-field at any point in the region of $x = -6.5 \mu m$ to $x = -4 \mu m$ and $x = 7.5 \mu m$ to $x = 10 \mu m$ can be approximated as a fifth degree polynomial:

$$E_x = -0.12459 \cdot x^5 - 2.8822 \cdot x^4 - 26.573 \cdot x^3 - 121.84 \cdot x^2 - 277.59 \cdot x - 249.79. \quad (3)$$

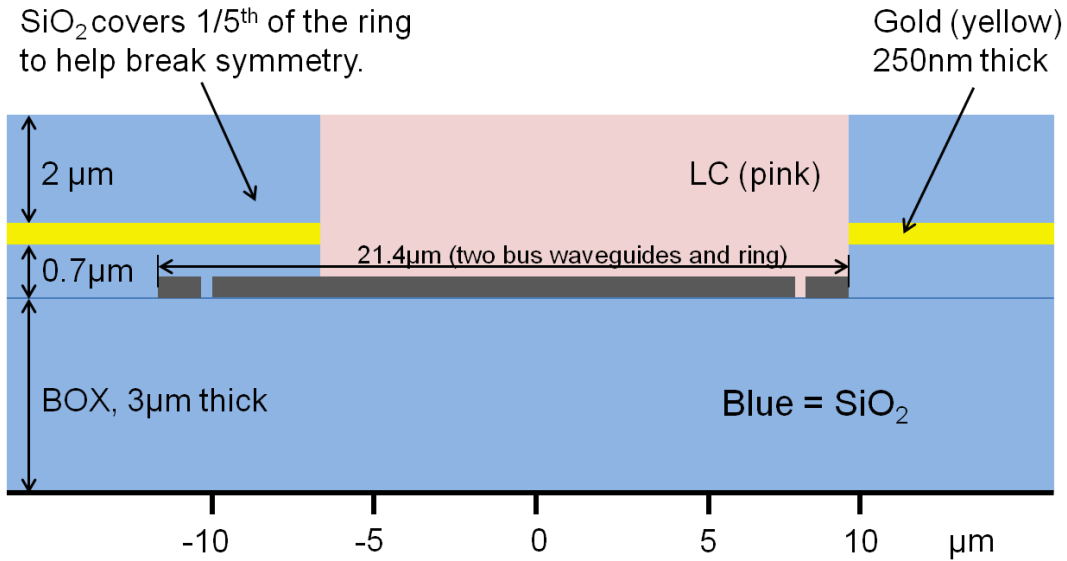

Figure 4. The electrodes are placed 0.7 μm above the BOX layer and a fifth of the ring is covered by SiO₂. The Si ring and the bus waveguides are both 250 nm tall (depicted in gray).

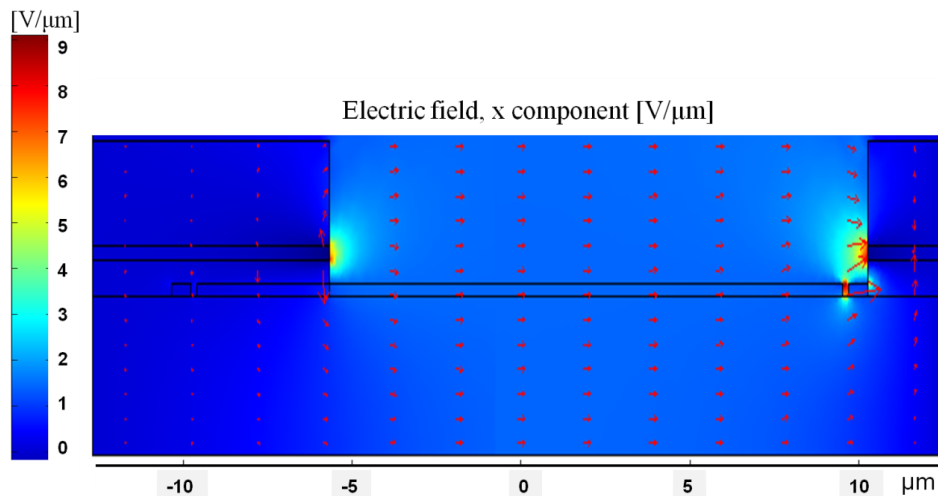

Figure 5. Simulation showing the electric field x-component when a potential is applied to the electrodes.

At a potential of 38 V, the E-field for most of sample is 1.81 V/μm. This is above the threshold voltage of LIXON™, $V_t = 1.61$ V. The electric field x-component for a 38-V applied potential is shown in Figure 7. Figure 8 shows the electric field distribution in the case when a 53-V potential is applied. The field at any point on the sample is equal to or greater than 2.52 V/μm, which is 0.01 V/μm higher than the saturation voltage of LIXON™.

How do the applied fields correspond to the extent of the ring resonator tuning range? Figure 5 shows a simulation result for an applied potential of 0 to 53 V and the resulting electric field x-component, as well as the change in the resonant peak caused by LC reorientation. The maximum ring resonator tuning range is 9 nm. With an applied potential of 30 and 34 V, the fringe field for most of the sample is 1.43 and 1.62 V/μm, respectively. The voltage of 1.62 V/μm is slightly above the threshold voltage of LIXON™. Nevertheless, resonator tuning takes place at these low electric field values. The large fringe fields present near the electrodes are responsible for this effect.

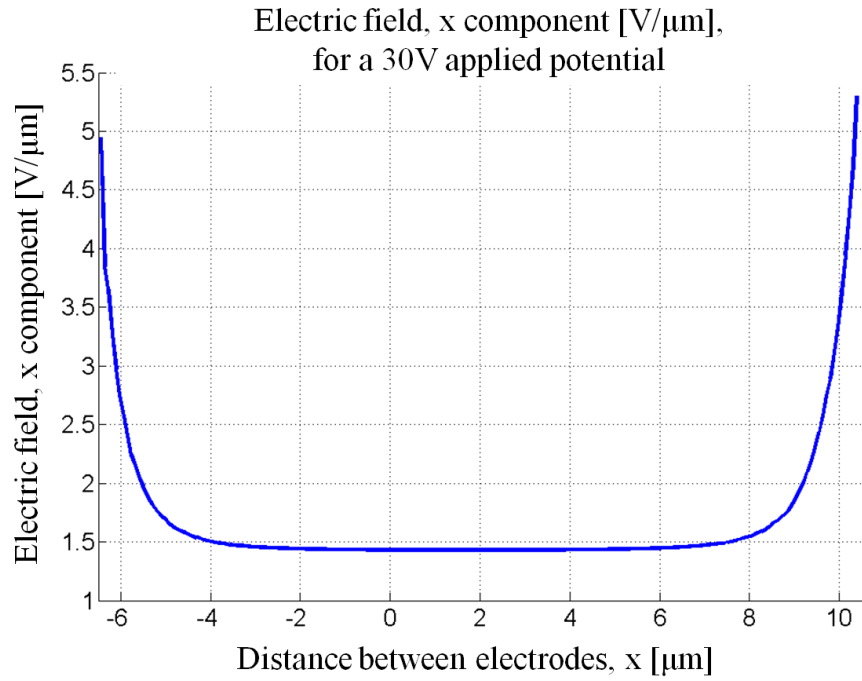

Figure 6. Electric field x-component for a 30-V applied potential and a fifth of the ring covered by SiO_2 .

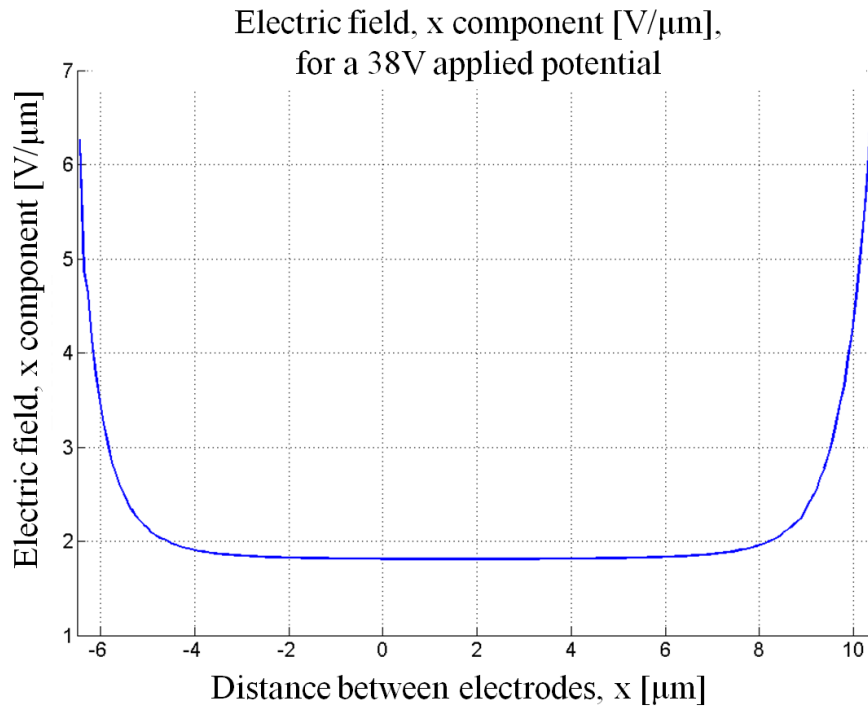

Figure 7. Electric field x-component for a 38-V applied potential and a fifth of the ring covered by SiO_2 .

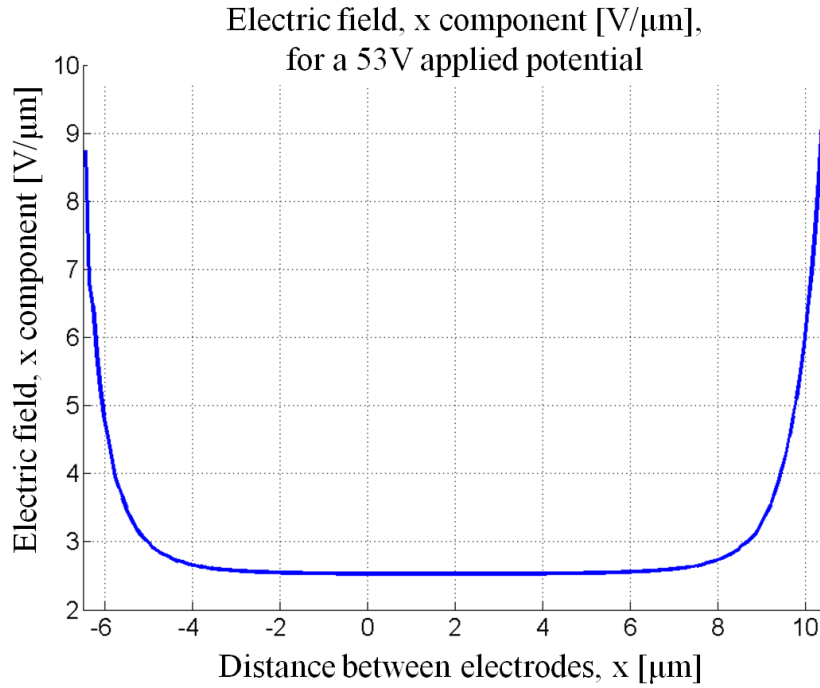

Figure 8. Electric field x-component for a 45-V applied potential and a fifth of the ring covered by SiO₂.

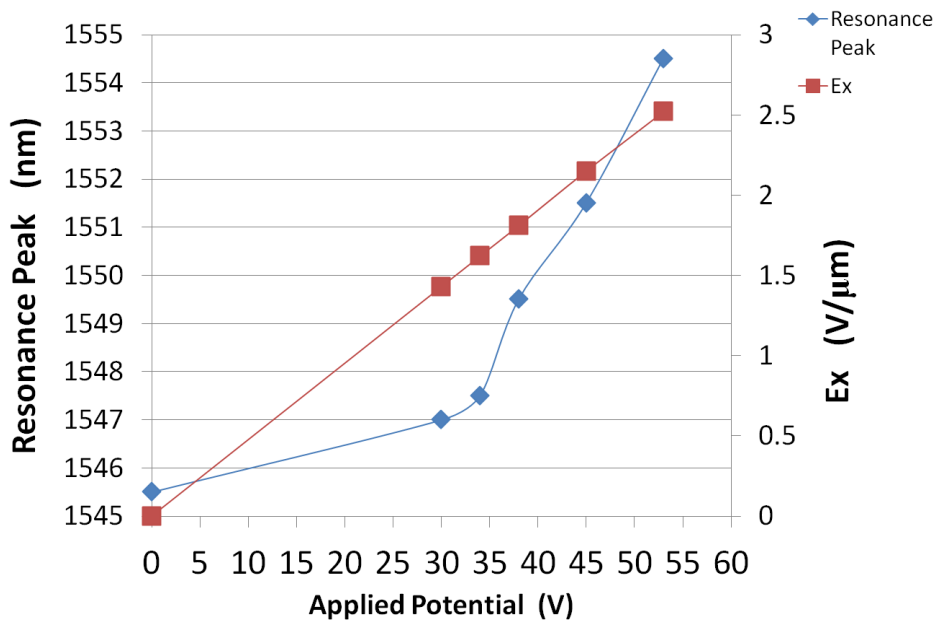

Figure 9. Electric field x-component and resonant peak tuning as a function of applied potential when a fifth of the ring is covered by SiO₂.

If the electrodes are brought closer together by extending the SiO₂ layer halfway through the ring, the potential required to tune the liquid crystals is smaller, but the LIXON™ tuning range is also reduced. To aid in expanding the LIXON™ tuning range without sustaining large propagation losses, the electrodes are brought 50 nm closer to the edge of the BOX layer. Figure 10 shows the geometry

of the model. Figure 11 shows the electric field x-component for a 25-V applied potential. The field for most of the sample is $1.68 \text{ V}/\mu\text{m}$, which is above the threshold voltage of LIXON™. Saturation voltage, $V_{\text{sat}} = 2.51 \text{ V}$, is achieved with an applied field of 38 V, as shown in Figure 12. The potential fields required to achieve tuning are of considerably smaller value in the case when the electrodes are brought closer together. The maximum tuning range achieved with this configuration is 6 nm (Figure 13). In practice, the optimum electrode placement must be chosen dependent on the desired application and power budget.

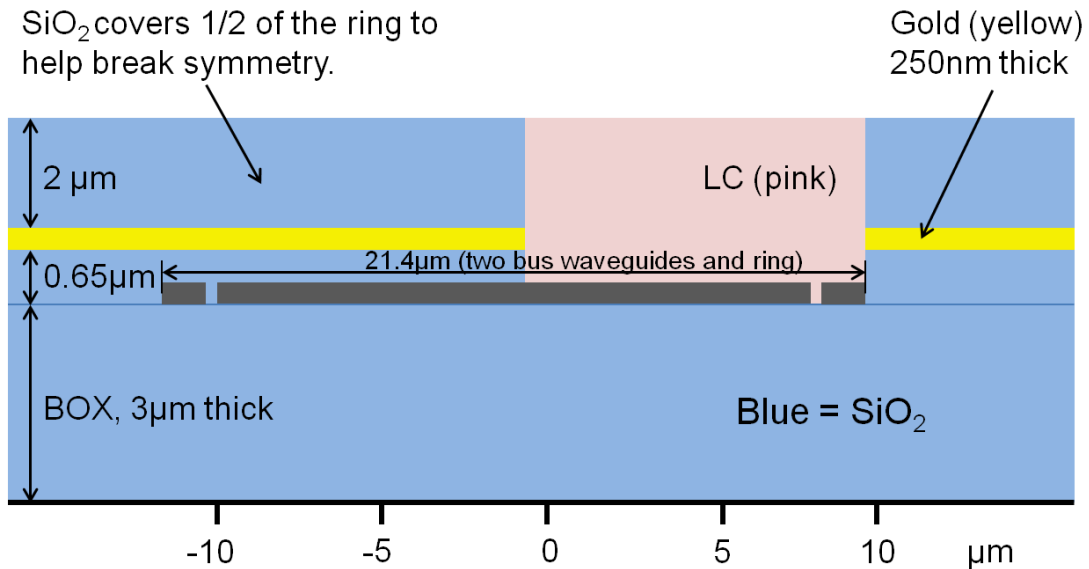

Figure 10. The electrodes are placed $0.65 \mu\text{m}$ above the BOX layer and one-half of the ring is covered by SiO₂. The Si ring and the bus waveguides are both 250-nm tall (depicted in gray).

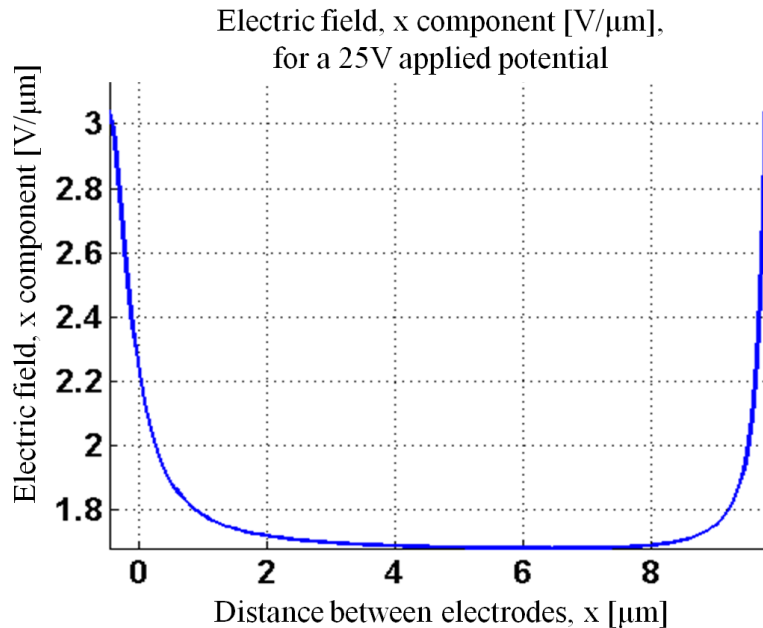

Figure 11. Electric field x-component for a 25-V applied potential and one-half of the ring covered by SiO₂.

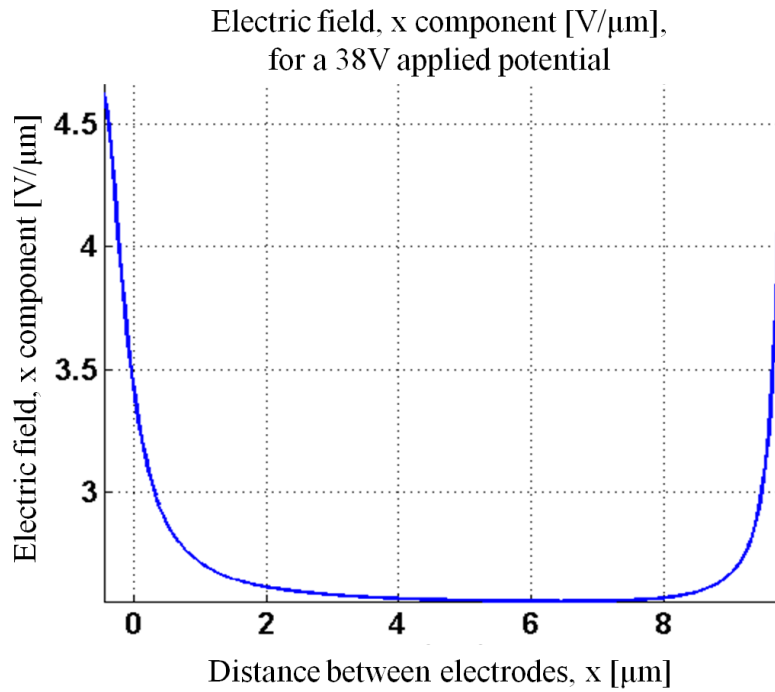

Figure 12. Electric field x-component for a 38-V applied potential and one-half of the ring covered by SiO_2 .

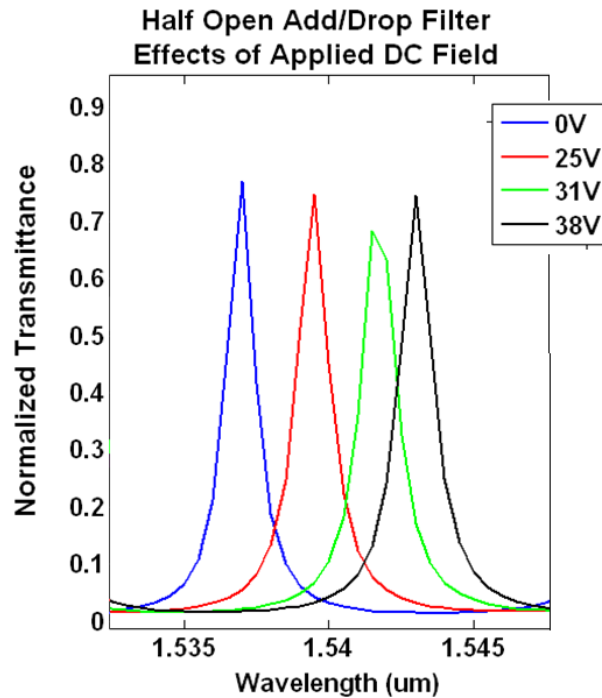

Figure 13. Resonant peak tuning as a function of applied potential when one-half of the ring is covered by SiO_2 .

3. CONCLUSIONS

In conclusion, the effect of electrode placement for electrically tunable ring resonators was analyzed. The symmetric ring resonator geometry plays a role in the total amount of achievable resonance shift. Factors governing the overall amount of resonance shift include the perimeter of the ring, the amount of the ring covered by SiO₂, and the waveguide propagation loss influenced by the location of the metal layer above the BOX.

4. REFERENCES

1. W. W. Bogaerts, P. De Heyn, T. Van Vaerenbergh, K. DeVos, S. K. Selvaraja, T. Claes, P. Dumon, P. Bienstman, D. Van Thourhout, and R. Baets. 2012. "Silicon Microring Resonators," *Laser & Photonics Reviews* 6(1):47–73.
2. X. Wang, S. Grist, J. Flueckiger, N. Jaeger, and L. Chrostowski. 2013. "Silicon Photonic Slot Waveguide Bragg Gratings and Resonators," *Optics Express* 21:19029–19039.
3. M. S. Luchansky and R. C. Bailey. 2010. "Silicon Photonic Microring Resonators for Quantitative Cytokine Detection and T-Cell Secretion Analysis," *Analytical Chemistry* 82(5):1975–1981.
4. I. C. Khoo, M. V. Wood, M. Y. Shih, and P. H. Chen. 1999. "Extremely Nonlinear Photosensitive Liquid Crystals for Image Sensing and Sensor Protection," *Optics Express* 4:432–442.
5. J. Ptasinski, S. Kim, L. Pang, I. Khoo, and Y. Fainman. 2013. "Optical Tuning of Silicon Photonic Structures with Nematic Liquid Crystal Claddings," *Optics Letters* 38:2008–2010.

REPORT DOCUMENTATION PAGE

*Form Approved
OMB No. 0704-01-0188*

The public reporting burden for this collection of information is estimated to average 1 hour per response, including the time for reviewing instructions, searching existing data sources, gathering and maintaining the data needed, and completing and reviewing the collection of information. Send comments regarding this burden estimate or any other aspect of this collection of information, including suggestions for reducing the burden to Department of Defense, Washington Headquarters Services Directorate for Information Operations and Reports (0704-0188), 1215 Jefferson Davis Highway, Suite 1204, Arlington VA 22202-4302. Respondents should be aware that notwithstanding any other provision of law, no person shall be subject to any penalty for failing to comply with a collection of information if it does not display a currently valid OMB control number.

PLEASE DO NOT RETURN YOUR FORM TO THE ABOVE ADDRESS.

1. REPORT DATE (DD-MM-YYYY) August 2014		2. REPORT TYPE Final	3. DATES COVERED (From - To)		
4. TITLE AND SUBTITLE Electrode Placement for Active Tuning of Silicon-on-Insulator (SOI) Ring Resonator Structure Clad in Nematic Liquid Crystals			5a. CONTRACT NUMBER		
			5b. GRANT NUMBER		
			5c. PROGRAM ELEMENT NUMBER		
6. AUTHORS J. Ptasinski			5d. PROJECT NUMBER		
			5e. TASK NUMBER		
			5f. WORK UNIT NUMBER		
7. PERFORMING ORGANIZATION NAME(S) AND ADDRESS(ES) SSC Pacific, 53560 Hull Street, San Diego, CA 92152-5001			8. PERFORMING ORGANIZATION REPORT NUMBER TD 3282		
9. SPONSORING/MONITORING AGENCY NAME(S) AND ADDRESS(ES) Naval Innovative Science and Engineering (NISE) Program (Basic Research) SSC Pacific, 53560 Hull Street, San Diego, CA 92152-5001			10. SPONSOR/MONITOR'S ACRONYM(S) NISE		
			11. SPONSOR/MONITOR'S REPORT NUMBER(S)		
12. DISTRIBUTION/AVAILABILITY STATEMENT Approved for public release.					
13. SUPPLEMENTARY NOTES This is work of the United States Government and therefore is not copyrighted. This work may be copied and disseminated without restriction.					
14. ABSTRACT This technical report analyzes the optimum electrode placement for electrically tunable ring resonators. Combining these resonators with nematic liquid crystals enables easily tunable devices where the tuning is performed through either electrical or optical means. Electrode placement determines the total amount of a resonance shift that can be achieved. Simulation results contained within this report were performed using COMSOL Multiphysics® for a 500-nm wide, 250-nm tall silicon waveguide surrounded by SiO ₂ and liquid crystals. The 500-nm wide waveguide confines most of the optical mode to its core. The effect of electrode placement for electrically tunable ring resonators was analyzed. The symmetric ring resonator geometry plays a role in the total amount of achievable resonance shift. Factors governing the overall amount of resonance shift include the perimeter of the ring, the amount of the ring covered by SiO ₂ , and the waveguide propagation loss influenced by the location of the metal layer above the buried oxide (BOX).					
15. SUBJECT TERMS Mission Area: Environmental Science dielectric resonators liquid crystal tuning dataloggers stratification nematic liquid crystals acoustic Doppler current profilers water surface elevation vertical mixing					
16. SECURITY CLASSIFICATION OF:			17. LIMITATION OF ABSTRACT	18. NUMBER OF PAGES	19a. NAME OF RESPONSIBLE PERSON
a. REPORT	b. ABSTRACT	c. THIS PAGE			J. Ptasinski
U	U	U	U	44	19b. TELEPHONE NUMBER (Include area code) (619) 553-3727

INITIAL DISTRIBUTION

84300	Library	(2)
85300	Archive/Stock	(1)
55360	J. Ptasinki	(1)

Defense Technical Information Center Fort Belvoir, VA 22060-6218	(1)
---	-----

Approved for public release.



SSC Pacific
San Diego, CA 92152-5001