

SMALL COUNTRIES' SPECIAL OPERATIONS FORCES CONTRIBUTION
TO THE NATO RESPONSE FORCE

A thesis presented to the Faculty of the U.S. Army
Command and General Staff College in partial
fulfillment of the requirements for the
degree

MASTER OF MILITARY ART AND SCIENCE
General Studies

by

MENTOR SAITI, MAJOR, MACEDONIAN ARMY
B.S., Military Academy, Skopje, Macedonia, 2002

Fort Leavenworth, Kansas

2014-01

Approved for public release; distribution is unlimited.

REPORT DOCUMENTATION PAGE			<i>Form Approved</i> OMB No. 0704-0188		
Public reporting burden for this collection of information is estimated to average 1 hour per response, including the time for reviewing instructions, searching existing data sources, gathering and maintaining the data needed, and completing and reviewing this collection of information. Send comments regarding this burden estimate or any other aspect of this collection of information, including suggestions for reducing this burden to Department of Defense, Washington Headquarters Services, Directorate for Information Operations and Reports (0704-0188), 1215 Jefferson Davis Highway, Suite 1204, Arlington, VA 22202-4302. Respondents should be aware that notwithstanding any other provision of law, no person shall be subject to any penalty for failing to comply with a collection of information if it does not display a currently valid OMB control number. PLEASE DO NOT RETURN YOUR FORM TO THE ABOVE ADDRESS.					
1. REPORT DATE (DD-MM-YYYY) 13-06-2014		2. REPORT TYPE Master's Thesis		3. DATES COVERED (From - To) AUG 2013 – JUN 2014	
4. TITLE AND SUBTITLE Small Countries' Special Forces Contribution to the NATO Response Force			5a. CONTRACT NUMBER		
			5b. GRANT NUMBER		
			5c. PROGRAM ELEMENT NUMBER		
6. AUTHOR(S) Major Mentor Saiti, Macedonian Army			5d. PROJECT NUMBER		
			5e. TASK NUMBER		
			5f. WORK UNIT NUMBER		
7. PERFORMING ORGANIZATION NAME(S) AND ADDRESS(ES) U.S. Army Command and General Staff College ATTN: ATZL-SWD-GD Fort Leavenworth, KS 66027-2301			8. PERFORMING ORG REPORT NUMBER		
9. SPONSORING / MONITORING AGENCY NAME(S) AND ADDRESS(ES)			10. SPONSOR/MONITOR'S ACRONYM(S)		
			11. SPONSOR/MONITOR'S REPORT NUMBER(S)		
12. DISTRIBUTION / AVAILABILITY STATEMENT Approved for Public Release; Distribution is Unlimited					
13. SUPPLEMENTARY NOTES					
14. ABSTRACT The creation of the NATO Response Forces (NRF) has played a significant role in the NATO transformation to meet the challenges of the 21st century and a new opportunity for interoperability between North Atlantic Treaty Organization (NATO) countries and partners. As the withdrawal of NATO from Afghanistan starts to unfold, NRF seems to be the tool for the future. The vast majority of the NATO and partner small countries had focused on developing Special Operations Forces (SOF) capabilities to contribute to NATO, as a cost efficient capability to develop that can achieve bigger effects aiteration with other countries, these capabilities can be enhanced. Since NRF is expected to take the lead in future NATO operations, this research focuses on the ways the small countries' SOF can contribute to the NRF.					
15. SUBJECT TERMS NATO Response Force, Special Operation Forces, North Atlantic Treaty Organization, Special Operations Task Group, Special Operations Task Unit, Niche Capability					
16. SECURITY CLASSIFICATION OF:			17. LIMITATION OF ABSTRACT	18. NUMBER OF PAGES	19a. NAME OF RESPONSIBLE PERSON
a. REPORT	b. ABSTRACT	c. THIS PAGE			19b. PHONE NUMBER (include area code)
(U)	(U)	(U)	(U)	87	

Standard Form 298 (Rev. 8-98)
Prescribed by ANSI Std. Z39.18

MASTER OF MILITARY ART AND SCIENCE

THESIS APPROVAL PAGE

Name of Candidate: Major Mentor Saiti

Thesis Title: Small Countries' Special Operations Forces Contribution to the NATO Response Force

Approved by:

_____, Thesis Committee Chair
James R. Cricks, M.A.

_____, Member
Terry L. Beckenbaugh, Ph.D.

_____, Member
LTC Solomon Woods, M.A.

Accepted this 13th day of June 2014 by:

_____, Director, Graduate Degree Programs
Robert F. Baumann, Ph.D.

The opinions and conclusions expressed herein are those of the student author and do not necessarily represent the views of the U.S. Army Command and General Staff College or any other governmental agency. (References to this study should include the foregoing statement.)

ABSTRACT

SMALL COUNTRIES' SPECIAL OPERATIONS FORCES CONTRIBUTION TO THE NATO RESPONSE FORCE, by Major Mentor Saiti, 87 pages.

The creation of the NATO Response Forces (NRF) has played a significant role in the NATO transformation to meet the challenges of the 21st century and a new opportunity for interoperability between North Atlantic Treaty Organization (NATO) countries and partners. As the withdrawal of NATO from Afghanistan starts to unfold, NRF seems to be the tool for the future.

The vast majority of the NATO and partner small countries had focused on developing Special Operations Forces (SOF) capabilities to contribute to NATO, as a cost efficient capability to develop that can achieve bigger effects aiteration with other countries, these capabilities can be enhanced. Since NRF is expected to take the lead in future NATO operations, this research focuses on the ways the small countries' SOF can contribute to the NRF.

ACKNOWLEDGMENTS

I wish to give special thanks to my research committee and their contribution towards the completion of this master's program. Mr. James Cricks, Dr. Terry Beckenbaugh and LTC Solomon Woods, your guidance, advice and support have helped me to successfully accomplish this endeavor called MMAS for which I am so grateful. I would like to show my deepest gratitude to my thesis committee chair, Mr. James Cricks for his guidance, mentorship, patience, and support in organizing my thoughts during the research.

Finally, I owe an enormous gratitude to my lovely wife, Rezijana, and my daughters, Doa and Tara, for their unselfish support during the entire time. Without their love, patience, encouragement, and sacrifice I would have not been able to accomplish this effort.

TABLE OF CONTENTS

	Page
MASTER OF MILITARY ART AND SCIENCE THESIS APPROVAL PAGE	iii
ABSTRACT.....	iv
ACKNOWLEDGMENTS	v
TABLE OF CONTENTS.....	vi
ACRONYMS.....	viii
ILLUSTRATIONS	ix
TABLES	x
CHAPTER 1 INTRODUCTION	1
The Research Question	4
Assumptions.....	5
Definitions	6
Scope.....	8
Limitations	8
Significance of the Study	9
CHAPTER 2 LITERATURE REVIEW	11
CHAPTER 3 RESEARCH METHODOLOGY	20
CHAPTER 4 FINDINGS AND ANALYSIS	22
NRF as a Transformation Tool and a Mechanism to Meet the New Threats	22
NRF’s Standing Structure	25
NRF Mission, Rotations, Engagements (Past and Future).....	29
NRF’s Training and Interoperability	35
Small Countries’ SOF Engagements within NRF	36
Joint Employment under a Bigger NATO SOF Force.....	40
Doctrine.....	46
Organization.....	47
Training.....	47
Materiel	49
Leadership.....	49
Personnel.....	50
Facilities	50

Interoperability.....	50
Joint Employment as a Regional Group of Small Nations	51
Doctrine.....	54
Organization.....	55
Training.....	55
Materiel	56
Leadership.....	57
Personnel.....	57
Facilities	57
Interoperability.....	58
NATO SOF Requirements.....	58
Providing Niche Support to NATO	63
 CHAPTER 5 CONCLUSION AND RECOMMENDATIONS	 68
Recommendations.....	72
 BIBLIOGRAPHY.....	 74

ACRONYMS

CJFSOCC	Combined Joint Force Special Operations Component Command
DOTMLPFI	Doctrine Organization Training Materiel Leadership Personnel Facilities Interoperability
ISAF	International Security Assistance Forces
NA5CRO	Non-Article 5 Crisis Response Operation
NATO	North Atlantic Treaty Organization
NRF	NATO Response Force
SOF	Special Operations Forces
SOTG	Special Operations Task Group
SOTU	Special Operations Task Unit
SOLTU	Special Operations Land Task Unit

ILLUSTRATIONS

	Page
Figure 1. NRF Structure	27
Figure 2. Immediate Response Force Structure	28
Figure 3. NATO CJFSOCC Organization.....	41

TABLES

	Page
Table 1. Example of SOTG Manning	43
Table 2. Defense Budget	63

CHAPTER 1

INTRODUCTION

During the 1990s, North Atlantic Treaty Organization (NATO) was mainly preoccupied with Alliance enlargement and related security affairs in the Euro-Atlantic area. At the Washington summit in 1999, it was stated that NATO's core strategic purposes are to safeguard the freedom and security of its members by political and military means, preserve the transatlantic link that binds the United States to Europe, and maintain Alliance cohesion and unity so that all members are protected equally.¹ However, the changed international security environment, and the introduction of the asymmetric threats has dictated the need for a new approach. As the non-state actors started to use terrorism for their own political, ideological, or financial gain, and prepared to use even weapons of mass destruction to achieve their aims, NATO had found itself poorly prepared to provide a credible response to these threats.² Instead of fighting an adversary on static battlefields with a force that is well prepared to fight a war of attrition, NATO required an agile and flexible force that can be proactive, capable of using maneuver on today's non-linear battlefield, and applying military force in discrete, timely, and precise packages whenever and wherever the threat emerges.³ This was a

¹Javier Solana, "The Washington Summit: NATO Steps Boldly into the 21st Century," North Atlantic Treaty Organization, <http://www.nato.int/docu/review/1999/9901-01.htm> (accessed 12 January 2014).

²Ian Garnett, "NATO Response Force," *RUSI Journal* 148, no. 6 (December 2003): 20-25, <http://search.proquest.com/docview/212112747?accountid=28992> (accessed 14 January 2014).

³Ibid.

clear indication that a transformation was needed. The response of these changes was the creation of the NATO Response Force (NRF) consisting of land, air, maritime and Special Operation Forces (SOF).⁴ The new force was about to be the solution to the new threats and the tool for NATO's new transformation. However, force generation was another issue that NATO was facing. By providing certain capabilities and forces on a rotational basis by the nations, NRF proved to be very resourceful in force generating and cost effective.

NATO and small partner countries had focused on developing SOF capabilities as one of the best ways to contribute to NATO. As budget austerity strains an alliance already plagued by defense underspending, most of the NATO and small Allied countries, were unable to provide major capabilities to the Alliance. The last global economic crisis that occurred in 2008 affected NATO and partner countries' budgets that reflected in NATO's overall performance. Years ago the vast majority of NATO countries had already dipped below the threshold of two percent of Gross Domestic Product for defense spending and were heading for one percent,⁵ which resulted in a lack of providing relevant military forces. The "Smart Defense" concept launched in February 2010 by the Secretary General at the security conference in Munich, aimed to deliver

⁴North Atlantic Treaty Organization (NATO), "The NATO Response Force," 22 February 2013, http://www.nato.int/cps/en/natolive/topics_49755.htm (accessed 10 October 2013).

⁵Dr. Lisa Aronsson and Dr. Molly O'Donnell, "Smart Defense and the Future of NATO: Can the Alliance Meet the Challenges of the Twenty-First Century?"(Conference Report and Expert Papers, The Chicago Council on Global Affairs, Chicago, IL, 28-30 March 2012), 45.

capabilities in a more efficient and cost-effective manner.⁶ Based on this concept, NATO would assess the capabilities shortfalls and require the states not to prepare for the full range of contingencies, but rather to concentrate on a narrower set of deficit capabilities.⁷ Simply said, the Alliance would fill in the capability gaps through the concepts of resource pooling, capabilities sharing, and niche specialization.

The post-9/11 security environment characterized with the growth of terrorism and asymmetrical threats, proved SOFs indispensability. Because SOF plays an enormous role in NATO's current and future operations, and it is more affordable to develop and maintain, developing this niche capability for the smaller countries has proven to be the best way to contribute to the Alliance.

In the past decade, small countries have conducted different multilateral cooperations and put efforts into maximizing their effectiveness. As part of this cooperation, several SOF concepts, such as the B-9,⁸ or the Baltic States Special Operations Forces,⁹ have been developed and have proven to be effective in providing more capable and robust SOF to NATO. In their previous engagements as part of NATO led operations, small countries' SOF were usually deployed as part of a bigger NATO SOF structure, usually with a Special Operations Task Unit (SOTU). This way of

⁶Ibid., 46.

⁷Paul Johnson, Tim LaBenz, and Darrell Driver, "Smart Defense Brave New Approach or Déjà Vu?" *Naval War College Review* 66, no. 3 (Summer 2013): 41.

⁸Chiefs of Defense agreement for military cooperation among nine Balkan countries (Albania, Bosnia and Hercegovina, Bulgaria, Greece, Macedonia, Romania, Serbia, Turkey and Montenegro) signed on 10 May 2007 in Brussels.

⁹Concept for cooperative defense among Baltic States SOF (Lithuania, Latvia and Estonia) in order to build a robust collective defense.

employment proved to be very effective and helpful for small countries' SOF. Working together with a bigger and mature SOF had improved their proficiency and helped small countries develop better SOF capabilities. In the past decade, most of the small countries, have been partnering with U.S. SOF and a few of the larger European countries' SOF.

As the NATO mission in Afghanistan starts to unfold, NRF can play a crucial role in NATO's future contingencies as a highly ready and technologically advanced multinational force. In this regard, within the NRF's SOF element, it is important to determine ways in which small countries' SOF can be best utilized and fulfill their commitment to contribute to NATO/NRF engagements.

The Research Question

The creation of the NRF has played a significant role in the NATO transformation and as a new opportunity for interoperability between NATO countries and partners. Though since its formation, NRF has not been engaged in combat operations, it is expected to be the key tool for future NATO operations. In past NATO led operations, SOF played a pivotal role. Small countries' SOF had contributed greatly in those operations. With NRF taking the lead as an expeditionary force in future NATO contingencies, SOF will have to prove their legacy and their pivotal role. Regarding their capabilities and austerities from low military budgets, NATO and small partner countries should continue to contribute to NRF.

This research focuses on determining ways of employment and contribution for small countries' SOF to NRF. The primary research question for this research is: How can small countries' SOF contribute to NRF?

To answer the primary question, the research addresses two secondary questions: (1) What resources will be required? and (2) What are the risks of providing niche support to NATO?

Answering these questions is crucial and necessary in order to provide guidance in which direction small countries' SOF should focus their priorities and development in order to contribute to NRF. The answers provided guidance on what small countries' SOF should do to better utilize their capabilities and contribute to NRF. An answer to the main question provides ideas for further development and collaboration among small countries' SOF as well as larger and more mature SOF with smaller and less capable SOF.

Assumptions

At its 2002 summit in Prague, the Allies began to adapt to the changed security situation generated by the 9/11 attacks and to the prospect of helping to restore stability to Afghanistan. The Alliance approved a plan to augment the Defense Capability Initiative by developing improved capabilities in eight defense categories, established Allied Command Transformation to steer the development of those capabilities, and created a NRF to “move [forces] quickly to wherever needed.”¹⁰

In order to meet and defeat today's asymmetrical threats, most notably terrorism, modern, flexible, rapidly deployable joint forces are required. The NRF is that new force that should meet the threats of the 21st century. Based on these facts, NRF will continue

¹⁰NATO Rapid Deployable Corps (Italy), “NATO Response Forces 3,” 22 October 2013, <http://www.nato.int/nrdc-it/index.htm> (accessed 29 October 2013).

to be the centerpiece and an engine of change for the Alliance and take lead in the post-2014 operations in Afghanistan.

SOF will continue to be the cornerstone in fighting the new asymmetrical threats. As part of NRF, SOF will be the lead in fulfilling NRF's mission of being an expeditionary force capable of dealing with the new threats of the 21st century. Small countries' SOF, NATO, or partner countries, in cooperation with a bigger NATO SOF or in a joint effort with different small countries, can contribute significantly in future NRF contingencies. Joint training, resource pooling and sharing, and mutual support will be imperative in developing and maintaining a capable SOF ready to deploy in support of NRF missions. This thesis can be a relevant source to suggest further research useful for the development of small countries' SOF and their contribution to NATO/NRF.

Definitions

Interoperability: The ability of systems, units, or forces to provide services to and accept services from other systems, units, or forces and to use the services so exchanged to enable them to operate effectively together.¹¹

NATO Response Force (NRF): Highly ready and technologically advanced multinational force made up of land, air, maritime and SOF components that the Alliance can deploy quickly wherever needed.¹²

¹¹Joint Chiefs of Staff, Joint Publication (JP) 1-02, *Department of Defense Dictionary of Military and Associated Terms* (Washington, DC: US Government Printing Office, 8 November 2010, as amended through 15 March 2014), 135.

¹²NATO, "The NATO Response Force."

Niche Capabilities: A strategy under which a given country would opt to develop specialized capabilities that make high-value contributions to overall NATO efforts.¹³

Risk: Probability and severity of loss linked to hazards.¹⁴

Small Countries: NATO or partner countries that have a smaller military force up to 50,000 total active personnel.

Special Operations Forces (SOF): Those Active and Reserve Component forces of the Military Services designated by the Secretary of Defense and specifically organized, trained, and equipped to conduct and support special operations; also called SOF.¹⁵

Special Operations Task Group (SOTG): A national grouping of land, maritime, air SOF, employed to conduct Special Operations as directed by the Commander, Combined Joint Force Special Operations Component Command (JFSOCC). They can be joint and if necessary, combined.¹⁶

Special Operations Task Unit (SOTU): The lowest level of a SOF tactical-level combat element that is employed by air, land, or sea. It is capable of conducting the full range of special operations. A SOTU is normally comprised of 4-16 personnel, who are capable of operating as a split-team.¹⁷

¹³NATO Parliamentary Assembly, *160 DSCTC 08 E REV 1 - Current and Future Capability Priorities for the Atlantic Alliance*, 5 November 2007, <http://www.nato-pa.int/Default.asp?SHORTCUT=1474> (accessed 11 November 2013), para. 69.

¹⁴*Ibid.*, 229.

¹⁵Joint Chiefs of Staff, JP 1-02, 258.

¹⁶NATO Special Operations Coordination Center, *SOTG MANUAL*, Version 1.0 (Mons, Belgium: NATO, 11 December 2009), 1-6.

¹⁷*Ibid.*, 1-7.

Scope

This study will be focused on three areas: time frame, small countries, and military units. The focus of this thesis will be the period between 2006, when NRF obtained readiness status, and 2020 that ties to the NATO 2020 strategic concept. However, this thesis will touch some on the period from the establishment of the NRF in 2002. This research is focused on NATO and partner countries that have a small military force, up to 50,000 active personnel. The research does not cover all NATO and partner countries that fall under this definition, but focuses on: Albania, Croatia, Czech Republic, Estonia, Latvia, Lithuania, Macedonia and Hungary.

Regarding the military units, this thesis will focus on NATO and partner small countries' SOF and their past and present engagements and their capabilities to contribute to NRF. The contribution to NRF will mainly focus on determining ways of employment of these SOF units, regarding their size and their capabilities as part of a bigger force or as a combined force with different smaller countries.

Limitations

This research does not use any sensitive or classified documents. Due to the sensitivity and the classification of the information regarding SOF, the research of this thesis is based on the collection of information from open sources. Although the access to information related to detailed military capabilities was hindered by the confidential characteristic of this type of data, the amount of information provided by military analysts, Internet data, and other sources facilitated the development of this analysis. The accessibility to the information narrowed the scope on the countries analyzed in this

research. In this regard, the research was not able to provide enough information for all of the small countries' SOF.

In analyzing the previous engagements of the SOF from various countries, this research will not provide specifics on the conducted missions and the exact time when and place where they have been conducted. In defining the size and type of units that small countries can contribute to NRF and NATO SOF, this research focused only on Special Operations Land Task Units (SOLTU).

Significance of the Study

With the NRF taking lead over the major NATO operations and the post-2014 operations in Afghanistan, participation in the NRF will be of a great challenge and importance. Further development of SOF as a capability for the smaller countries that cannot afford to develop greater capabilities, can be beneficial for their contribution, and burden sharing within NATO.

However, other than allied SOF embedded in the NRF, NATO has no SOF capability, nor has the Alliance made it a top priority to expand, improve, and fit together member SOF capabilities.¹⁸ These high-value forces are increasingly essential to the shared security interests of all NATO members, and SOF of all partner countries could benefit from working together. This cooperation is especially significant for small countries' SOF that can gain much through sharing of expertise, SOF exchanges, training, and exercises under NATO. As stated earlier, that vast majority of small countries are focused on developing SOF as a niche capability and their engagement in

¹⁸David C. Gompert and Raymond C. Smith, "Creating a NATO Special Operations Force," *Defense Horizons*, no. 52 (March 2006): 2.

NRF. Working alongside larger and more mature SOF will help develop their SOF. Moreover, providing SOF capabilities will be more cost efficient for small countries. This study can serve as a guide for the small countries on how to focus on further development of their national SOF as well as developing concepts of joint employment with other small countries, under the NATO umbrella.

CHAPTER 2

LITERATURE REVIEW

Though the term NRF is a decade old, not many military personnel have a sufficient understanding of what it actually represents and what it is. This is because since the establishment of NRF, it has not been involved in many major operations. The literature review will provide a greater understanding of NRF and its role, but it is beyond the scope of this paper to examine all aspects of what NRF represents and what it does.

One of the major pitfalls of the literature review is the lack of research and publications regarding small countries' SOF and their contribution to NATO or other major operations led by NATO or other NATO members. Another pitfall is the classification of the SOF documents and their accessibility, because almost all the countries have restrictions on the type of past and present operations conducted by SOF. In order to answer the primary and the two secondary questions, the literature review was focused on previous open sources, SOF research, publications, articles, and internet sources.

In order to understand the concept of NRF, the literature review will first focus on the latest NATO transformation. Prague in 2002 and Riga in 2006 were two decisive summits that NATO conducted in order to finalize the work on establishing stages in the military transformation of NATO. The Prague summit ended with a declaration that, in

the aftermath of 9/11, the threat of terrorism is the single greatest challenge of the security environment.¹⁹

In the book, *A Transforming Gap?*, Terry Terriff, Frans Osinga and Theo Farrell describe that the 9/11 events had served as a catalyst in the sense that for the United States the time had come to press forward forcefully within NATO the need for military change.²⁰ In various NATO summits and meetings from December until the summit in Prague, U.S. Secretary of Defense Rumsfeld had made it clear that if NATO was to remain a relevant factor, it needed to not only embrace new missions but also improve Europe's military capabilities so it can accomplish those missions.²¹

With the approved NATO Prague Capability Commitments, actual implementation of the Prague Capability Commitments, and a new command structure including the NRF, NATO demonstrates the means to transform a 20th century Alliance into an effective military capability on the operational level for global military operations in the 21st century. Following all of the analysis and recommendations for a new expeditionary force, the NRF finally was created.²² Nations must contribute troops to the new force that would be forced to be interoperable. According to *A Transforming Gap?*, the latest NATO transformation is imposed and tightly connected to the transformation of

¹⁹NATO, "Prague Summit Declaration," 21 November 2002, updated 18 January 2008, <http://www.nato.int/docu/pr/2002/p02-127e.htm> (accessed 19 February 2014), para. 3.

²⁰Terry Terriff, Frans Osinga, and Theo Farrell, *A Transforming Gap?* (Redwood City, CA: Stanford University Press. 2010), 29.

²¹*Ibid.*

²²*Ibid.*, 33.

U.S. forces in order to have European expeditionary forces capable of operating with U.S. troops. As a conclusion, the author makes a point that based on this; the NRF is considered both a rapidly deployable force and a catalyst for transformation.

The Atlantic Council publication, *NATO Transformation: Problems & Prospects, a Compendium*, gives another point of view on the NATO transformation and NRF. Canadian Lieutenant General Michael Maisonneuve, who talks about challenges and opportunities for NATO transformation, generally supports the idea that the NRF has come to the stage to fill in the gap between the European forces and U.S. forces. The NRF should be the new small and potent multinational joint force that will move away from a “too big, too old and too static” structure.²³ NRF is going to be a small equipped and trained force to go into high intensity situations and fight decisively. The major point that Lieutenant General Maisonneuve makes is that this force will have the greatest implication for the U.S. Army.²⁴ Eventually, the NRF will be operating alongside U.S. troops, which will contribute to the burden sharing and international legitimacy in any future deployment. However, as a stand-alone force, it can be given its own mission and area of operations; but beyond that, NRF must be integrated with the U.S forces in order to operate.²⁵

Another source that brings a different perspective, is the research paper “The NRF: from a Key Driver of Transformation to a Laboratory of the Connected Force

²³Andrew J. Goodpaster and Arthur K. Cebrowski, *NATO Transformation: Problems & Prospects, a Compendium* (Washington, DC: The Atlantic Council of the United States, 2004), 7.

²⁴*Ibid.*, 10.

²⁵*Ibid.*, 11

Initiative” by Guillaume Lasconjarias. The question that arises in this paper is whether the NRF has accomplished the initial intent for which it was created, or is it just another force that duplicates the European forces. One thing for sure, so far NRF has been used only in non-combat operations (Olympic Games in Athens and earthquake relief in Pakistan). Another point is that since 2010, the NATO website has posted nothing new regarding the NRF, which indicates low level of interest.²⁶ This has raised concerns and doubts about NRF’s relevance especially after creation of the European rapid response force the European Union Battle Groups.²⁷ The discussion refers to these forces as complementary forces and that none of them have been proved on the battlefield. However, the paper argues that the NRF will remain a flagship of NATO’s cohesion for two reasons. First, participating in the NRF will not abandon the attained operational experience because of training on a regular basis. Nevertheless, NRF exercises could help identify the best capabilities, and make nations aware of what new capabilities will have to be developed in the future. Second, the NRF will continue to play an important role because it catalyzes interoperability and promotes multinational cooperation. Despite the fact that NRF was a visible outcome intensely supported by the United States to overcome the gap between European forces and U.S. forces, it was a tool to fill the gap between European forces after the gap occurred because of the Balkan engagements.

²⁶Guillaume Lasconjarias, No. 88, “The NRF: From a Key Driver of Transformation to a Laboratory of the Connected Forces Initiative” (Research Division, NATO Defense College, Rome, Italy, January 2013), 1.

²⁷Ibid., 2.

The paper also discusses the latest NRF reform, the so-called “NRF 2.0” stage.²⁸ This reform came because of a critical review in 2008-2009 and the need for a larger force, permanent control, and longer missions for counter insurgency operation. This reform divided the force into an Immediate Response Force and a Response Forces Pool.²⁹ The new structure has made NRF more efficient. This paper concludes that NRF can be considered as a successful attempt to resolve difficulties encountered during the 1990s, that all forces coming from different backgrounds could achieve the same standards. In addition, as the scenario of withdrawal from Afghanistan starts to unfold, the NRF seems to be a tool for the future.³⁰

The article from the Institute for National Strategic Studies (October 2012), “Building Future Transatlantic Interoperability Around a Robust NATO Response Force” by Charles Barry, considers the NRF as one of NATO’s most successful initiatives. However, after almost 10 years since its founding, the concept suffers from three challenges that have persisted since its inception. These are the force generation shortfalls, the inability to employ the NRF as intended for high-level crisis response, and the rapid dissipation of the high level of interoperability that units achieve because of NRF experience.³¹ According to this research, the problem with the force generation shortfall comes because of overextended deployment of forces in Afghanistan and other

²⁸Ibid., 5.

²⁹Ibid.

³⁰Lasconjarias, 5.

³¹Charles Barry, “Building Future Transatlantic Interoperability Around a Robust NATO Response Force,” *Institute for National Strategic Studies, Transatlantic Current* no. 7 (October 2013): 6.

missions, the declining budgets and the real world requirements. On the other hand, the establishment of the Immediate Response Force and the Response Force Pool after 2008, and 2010 reformation of the NRF has eased the force generation problem to a certain extent.

The reluctance to use the NRF more often operationally is based on politics and finances, but the NRF's design for small and short duration missions also represents a barrier for its use. While NATO has agreed only to large, slowly evolving missions such as Implementation Force, Kosovo Force, and International Security Assistance Force (ISAF), NATO has not considered deploying the NRF for any major crisis response or combat mission.³²

The rapid dissipation of the high level of interoperability, according to this research is due to the present practice to train, perform the NRF rotation, and then disband permanently. As NATO's multinational operational requirements lessen, a training solution centered on the NRF should provide continuing opportunities.³³ Whether used operationally or not, the NRF provides substantial added value to NATO and nations, and must be preserved as the centerpiece of interoperability generation.

One of the proposals of this paper is that as soon as possible, the United States should propose to NATO a comprehensive strategy for sustaining future interoperability among members and partners in a period of reduced operations. A key element of the

³²Barry, 7.

³³Ibid.

strategy should be a vigorous transatlantic interoperability track that signals enduring U.S. interest and leadership.³⁴

In order to gain an understanding for one of the secondary questions of this thesis regarding the niche capabilities, the book *A Capabilities-Based Strategy for Army Security Cooperation* by Jennifer D.P. Moroney, Adam Grissom, and Jefferson P. Marquis, provides an excellent overview. This study outlines a planning framework for cultivating multinational force compatibility with armies that are not traditional Allies. Multilateral military operations are often now conducted by coalitions of the willing rather than by alliances, and many of these ad hoc coalitions include key contingents that have no history of sustained peacetime cooperation with the U.S. Army. This study outlines an approach to multinational force capability planning that focuses Army resources on potential coalition partners that possess, or with assistance could possess, niche capabilities that would augment U.S. Army capabilities in useful ways.³⁵ This approach is termed the Niche Capability Planning Framework, and has four phases. The first phase is prioritizing candidate niche capabilities to meet potential Army capability shortfalls. The second phase is assessing potential partner armies to identify those suited to becoming niche contributors. The third phase is development of an integrated program of military-to-military contacts, security assistance, and other security cooperation activities designed to cultivate capabilities in selected partner armies. The fourth and last phase is the execution of the phased program, coupled with continuing assessment and

³⁴Ibid., 11.

³⁵Jennifer D. P. Moroney, Adam Grissom, and Jefferson P. Marquis, *A Capabilities-Based Strategy for Army Security Cooperation* (Santa Monica, CA: Rand Arroyo Center, 2007), 13.

the development of appropriate measures of effectiveness.³⁶ Though this book generally compares the niche capabilities provided to the U.S Army, it can closely relate to NATO and the NRF in particular.

Dr. Hans Binnendijk, the Director of the Center for the Study and Technology and National Security Policy, in his May 2005 article, “A New Military Framework for NATO” in *Defense Horizons* argues that NATO must build capability while unity exists.³⁷ He argues for a capabilities based Alliance that stands ready for full-spectrum operations, including major combat, spanning diverse geographic locations. In order to achieve that readiness posture, Binnendijk advocates the development of a “warehouse of defense capabilities” which includes NATO SOF, NRF, NATO High Readiness Forces for major combat operations, NATO Stabilization and Reconstruction Force and NATO capacity for Defense and Security Sector Development for countries in transition.³⁸ Dr. Binnendijk further advocates that NATO SOF should have two components, a small inner core, and a larger outer network.³⁹ The inner core could be of a smaller size, focused on one or two vital missions, such as counterterrorism and counter-weapons of mass destruction, and composed of rotating national SOF units. The larger outer network should be of SOF assets from many nations that would perform such other missions as fire support, infiltration, intelligence gathering, and hostage rescue, peacetime advising of

³⁶Ibid., 15.

³⁷Hans Binnendijk, David C. Gompert, and Richard L. Kugler, “A New Military Framework for NATO,” *Defense Horizons*, no. 48 (May 2005): 17.

³⁸Binnendijk, Gompert, and Kugler, 5.

³⁹Ibid., 6.

new partners, civil affairs, and psychological operations. The SOF assets of this outer network must meet NATO standards and be available for commitment when the need arises.

CHAPTER 3

RESEARCH METHODOLOGY

In examining the small countries' SOF contribution to the NRF, the previous chapter reviewed the NRF concept from different schools of thought, the future role of the NRF, the niche capabilities the NATO SOF doctrine and a NATO Special Operations Headquarters NATO SOF study. This chapter will review the methodology employed in determining the answers to the primary and secondary research questions.

The research methodology used embodies a mixture of a qualitative research and comparative research through the Doctrine, Organization, Training, Materiel, Leadership, Personnel, Facilities, Interoperability (DOTMLPFI) domain. Through qualitative research of multiple documents, books and publications, this research analyzed the NRF as a concept from its formation to present, its previous engagements, and the future of NRF. The aim of this section was to gain an understanding of the requirements and capabilities needed to meet the NRF criteria. Furthermore, an analysis of the NATO SOF doctrine determined the criteria and requirements needed the nations to contribute SOF elements to NATO. This analysis provided a partial answer to the first secondary question regarding the resources needed to contribute SOF to NRF.

Further qualitative and comparative analysis was applied in analyzing documents and various data on some of the previous SOF engagements and employment of different small countries' SOF. This analysis categorized data into patterns as the primary basis for developing concepts for small countries' employments as part of the NRF. The comparative analysis determined the best pattern of employment and contribution of the small countries' SOF to NRF.

In order to determine the gaps and the advantages of the employment models for SOF, these concepts were analyzed using the DOTMLPFI domain. The employment of all DOTMLPF components would determine a more detailed set of solutions as each component would provide specific solutions that can decisively affect the way small countries' SOF can be employed and what resources are needed. This gives an in depth analysis and solutions to answer the first secondary question.

In answering the second secondary question, this research also applied qualitative research methodology that provided an overview of the concept of developing niche capabilities. In addition, this method was applied in analyzing small countries' capabilities and their possibility of developing niche capabilities in correlation with their nation's internal security versus their NATO contribution. This analysis provided the information needed to answer this secondary question.

A summary of the data gathered and the pragmatic analysis from the above mentioned research methodology provided the answers to the secondary questions that derive the answer to the primary question: How can small countries' SOF contribute to NRF?

CHAPTER 4

FINDINGS AND ANALYSIS

The previous chapter described the methodology used to answer the primary and secondary research questions. The methodology used provided precise and complete analysis and answers to the research questions. This chapter focuses on analysis and findings regarding the small countries' SOF capabilities and their contribution to the NRF.

The purpose of this research is to evaluate and determine ways that small countries' SOF can contribute to NRF. In order to understand this, chapter 4 will provide an overview of the NRF, NATO SOF, small countries SOF capabilities, the risk of providing niche support, and the changes needed for future NRF operations.

NRF as a Transformation Tool and a Mechanism to Meet the New Threats

The contemporary and future operating environment shapes future military capabilities. A simple statement like that is only valid if the identified threats are commonly agreed upon. Scholars identify three major future threats for NATO: international terrorism and its goal to strike worldwide; the proliferation of weapons of mass destruction; and failing states throughout the world.⁴⁰ NATO faced the necessity to transform its military capabilities to fit the contemporary and future operating environment. Due to the predominately-asymmetric character of contemporary and future

⁴⁰Michael Ruehle, "NATO after Prague: Learning the Lessons of 9/11," *Parameters* 33, no. 2 (Summer 2003): 89.

challenges, the Alliance needs to transform constantly in order to meet the challenges of the rapidly changing security environment.

The November 2002 Prague Summit was in a large part about transforming the Alliance to ensure its continuing relevance to today's security issues. The main thrust of this transformation was the creation of the NRF. The Prague Summit focused in a large part on transforming NATO to better meet the new security challenges. However, transformation is more than just simply buying updated equipment. It requires changes in DOTMLPFI. It is critically important that the Alliance members grow in the same direction to minimize interoperability problems in the future. The Prague Capabilities Commitments (PCC), the NRF, and the restructuring of the NATO commands are designed to work together to produce more capable and interoperable forces.⁴¹

The gap in capabilities between the United States and Europe is nothing new. For years, military analysts have warned about the consequences of the capabilities gap. What is different today is that the gap has grown on both sides. The United States is spending more pursuing increasingly advanced technology. In general, European defense spending has stagnated at post-Cold War lows. The danger is that at some point in the not too distant future, the two sides of the transatlantic Alliance will simply not be able to communicate or fight together in a meaningful way. It is no wonder then, that Richard Kugler of the U.S. National Defense University has called the reforms agreed to at Prague, "the last best hope for the Alliance."⁴²

⁴¹Julio Miranda Calha, *147 DSCTC 03 E - Reform of NATO Command Structure and the NATO Response Force*, November 2003, NATO Parliamentary Assembly, <http://www.nato-pa.int/default.asp?SHORTCUT=365> (accessed 17 March 2014), para. 2.

⁴²*Ibid.*

In his publication regarding NATO's progress in 2003 and 2004, "A New Military Framework for NATO," Dr. Hans Binnendijk discussed the approach to a force pyramid in order to deliver a holistic approach to needed capabilities. According to Dr. Binnendijk, in order to be able to deal with the challenges of future conflict scenarios and the wide spectrum of missions to NATO, transformation is needed to create a force capable of dealing with the challenges of the information age. Dr. Binnendijk states the Gompert and Kugler, a SOF capability, represents the top of the pyramid of forces that exemplifies NATO force capability.⁴³

The development of a military concept against terrorism is part of NATO's mission as well as the stated will of the Alliance to support the international community in ongoing and future missions. The creation of NRF enables the Alliance to react quickly with a deployable joint task force either as a building block for a bigger commitment in the form of a combined joint task force or as a force commitment to achieve a limited objective ranging from humanitarian assistance, to show of force missions, to counter terrorism.⁴⁴ Thus, the NRF is a high quality force element that is quickly deployable and adaptable to any crisis. Therefore, it will enhance capabilities and provide input to catalyze transformation.⁴⁵ NRF provides NATO with a robust and credible high readiness force, which is fully trained and certified as a joint combined force, and is able to deploy quickly to participate in the wide spectrum of NATO

⁴³Binnendijk, Gompert, and Kugler, 5.

⁴⁴NATO, "Prague Summit Declaration," para. 4a.

⁴⁵Luca Bonsignore, "NRF Key Element of NATO Transformation the NATO Response Force (NRF)," *NATO's Nations and Partners for Peace* 50, no. 2 (2005): 44-49.

missions when required. NRF also acts as a catalyst for collective Allied focus on capability development and as an engine for providing the Alliance with an expeditionary capability.

NRF's Standing Structure

The NRF is comprised of three parts: a command and control element from the NATO Command Structure; the Immediate Response Force, a joint force of about 13,000 high-readiness troops provided by Allies; and a Response Forces Pool, with undetermined size, which can supplement the Immediate Response Force when necessary.⁴⁶ NRF component commands come from nations (NATO Force Structure) and are organized under either a lead nation or one of the multinational commands: (1) Nine land component commands include seven High Readiness Corps (EuroCorps, FR, GE/NL, IT, SP, TK, UK/ARRC) and two corps at lower readiness (GR and Multinational Corps Northeast); (2) Five high readiness maritime forces (FR, IT, SP, UK and STRIKFORNATO); and (3) Four Joint Force Air Component Commands JFACC—(FR, GE, IT, and UK).⁴⁷

In addition to these commands, the Danish Rapid Reaction Division and 3rd UK Division have been certified as land component commands for a NRF rotation. Under the new NATO Command Structure, a deployed NRF is expected to most often be under the

⁴⁶NATO, "The NATO Response Force."

⁴⁷Barry, 4.

command of either Joint Force Headquarters Naples or Joint Force Headquarters Brunssum.⁴⁸

Taking into consideration NATO's role in Afghanistan after 2014, after ISAF completes its mission, the new concept of NRF is going to play a key role. The NRF are a highly ready and technologically advanced multinational force made up of land, air, maritime and special forces components that the Alliance can deploy quickly wherever needed.⁴⁹ Forces participating in the NRF will be high readiness deployable forces drawn from the entire NATO Force Structure, as well as from other forces offered by nations, on the basis that they meet the capability and high readiness criteria set by Supreme Allied Commander Europe.⁵⁰ NRF is held at a high readiness and able to be deployed within few days. Due to the high readiness status that NRF should have, the SOF component will play great role especially within the Immediate Response Force.

⁴⁸Ibid.

⁴⁹Ibid.

⁵⁰Ibid.

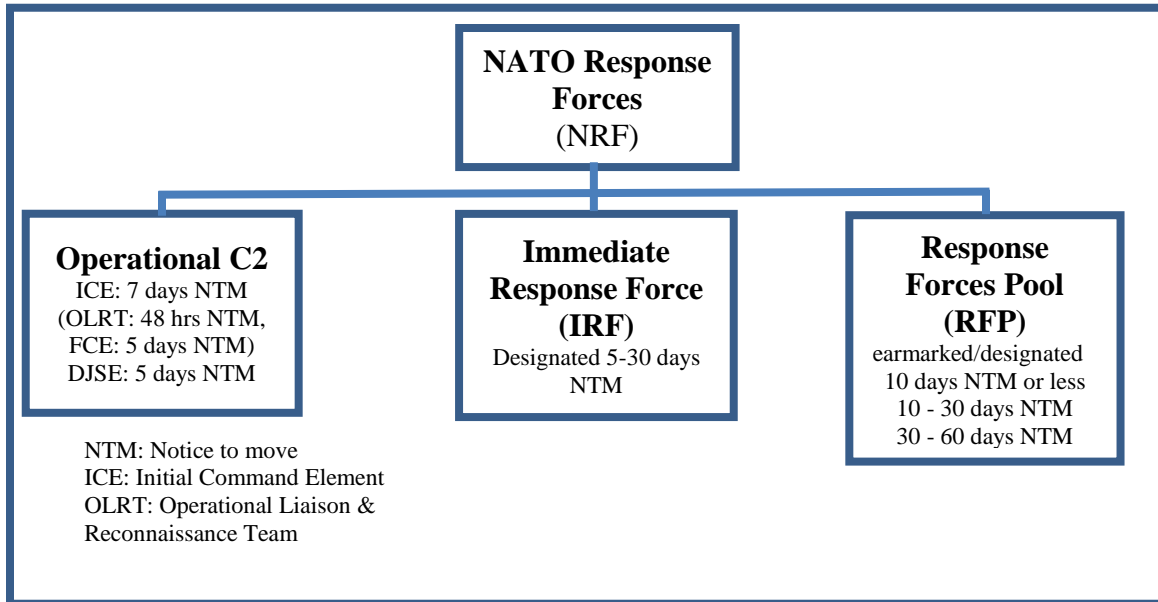

Figure 1. NRF Structure

Source: LtCol Rolland G. Iffert, “NATO Response Force” (Briefing to ‘NATO Staff Officer Orientation Course,’ M5-32-C-12, Oberammergau, Germany, 8 May 2012).

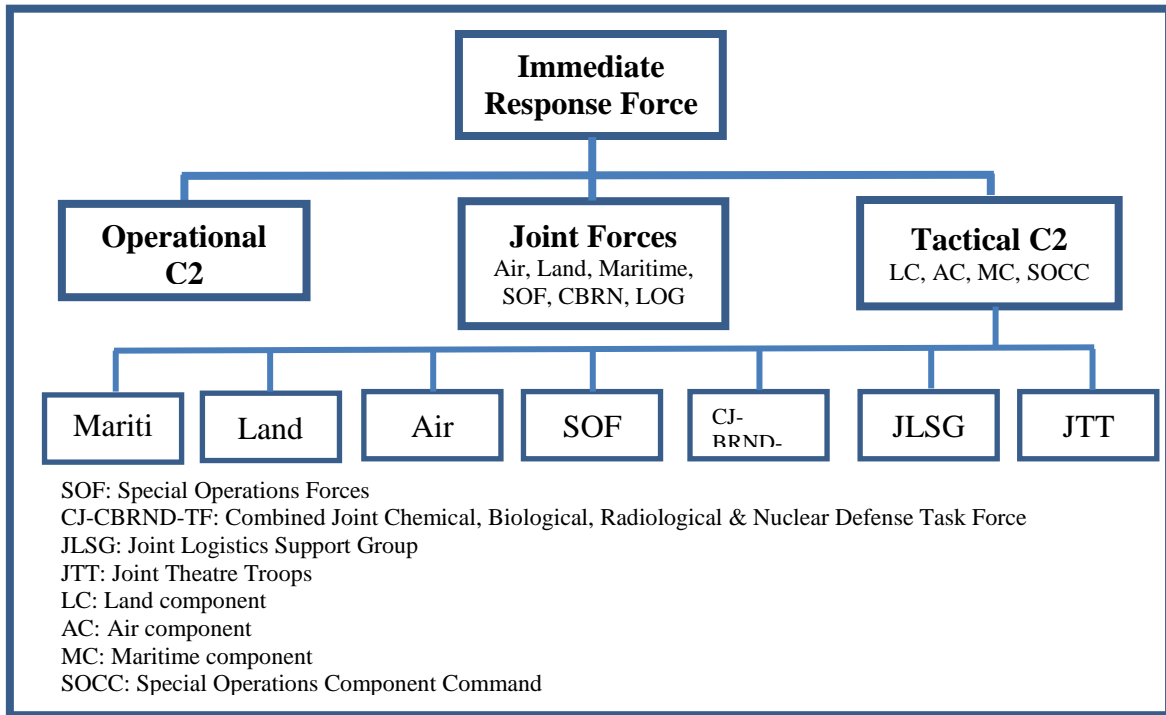

Figure 2. Immediate Response Force Structure

Source: LtCol Rolland G. Iffert, “NATO Response Force” (Briefing to ‘NATO Staff Officer Orientation Course,’ M5-32-C-12, Oberammergau, Germany, 8 May 2012), 14.

The NRF provides a mechanism to generate a high readiness and technologically advanced force package that can be deployed quickly on operations wherever needed. However, the force generation is a major issue for NRF.⁵¹ As most of the European countries are facing the austerity of the defense budgets and their over involvement in Afghanistan, they are not able to provide enough forces to NRF. As Mr. Guillaume Lasconjarias argues in his research paper, “The NRF: From a Key Driver of Transformation to a Laboratory of the Connected Forces Initiative,” participation in NRF is not only a political matter, but also an issue of manpower and resources. Participating

⁵¹Lasconjarias, 2.

nations in NRF, contribute either a volume based on percentage or specific capabilities based on units or equipment.⁵² Even though the last restructuring of the NRF (the revised concept 2008-2010) somewhat softened this issue, the force generation matter is still present.

NRF Mission, Rotations, Engagements (Past and Future)

NRF's official mission is to provide a rapid demonstration of force and the early establishment of a NATO military presence in support of an Article 5 or a Non-Article 5 Crisis Response Operation (NA5CRO).⁵³ In addition to the NRF mechanism providing the Alliance with a crisis management instrument, the NRF also serves as an engine for transformation of military capabilities through the cycle of building multinational force packages on a rotational basis, which then exercise together in order to integrate the operational and tactical levels of command and control and the joint forces.

The force package is capable of performing tasks across a wide spectrum of operations. Tasks could include providing an immediate response capability for conducting collective defense of Alliance members in the event of an Article 5 operation, acting as the initial force deployment as a precursor to deployment of a much larger force, whether that be for Article 5 or Non-Article 5, to allowing the Alliance to react with military forces to assist civilian agencies to manage the consequences of natural disasters.

⁵²Lasconjarias, 3.

⁵³LtCol Rolland G. Iffert, "NATO Response Force" (Briefing to 'NATO Staff Officer Orientation Course,' M5-32-C-12, Oberammergau, Germany, 8 May 2012), 5.

NRF's list of tasks includes contributing to the Preservation of Territorial Integrity, Demonstrative Force Package, Peace Support Operations, Embargo Operations, Disaster Relief, Protection of critical Infrastructure, Security Operations and as a part of a larger force. The NRF could also be used to conduct Initial Entry Operations.⁵⁴ However, these tasks can be prioritized on a rotational basis or based on current events. For 2012, NRF's priority tasks were peace support operations, collective defense, and disaster relief.⁵⁵ Even though NRF consists of all types of units and capabilities, for most of the above-mentioned tasks SOF plays a major role. Given the mission and the purpose to be an expeditionary unit, NRF should focus primarily on SOF capabilities. Through the complementary employment of direct and indirect approaches across the full range of potential military operations, the full potential of SOF is brought to bear.

Countries contributing forces to NRF rotations are required to meet the demanding standards required for expeditionary missions. This is the primary way the NRF acts as a catalyst for transformation of military capabilities spread throughout the forces of all member countries. In order to meet the very high standards, a six-month NATO program exercise precedes participation in the NRF in order to integrate and standardize the various national contingents. Generally, nations carry out a six to 18-month pre-training period in preparation for the NATO exercises. Beginning in 2012, once the overall preparation period of as much as 24 months has been accomplished, force are held on stand-by to deploy on operations for 12 months as opposed to the

⁵⁴Iffert, 7.

⁵⁵Ibid.

current six months.⁵⁶ This means a given national corps headquarters will only participate in the NRF once every nine or 10 years.

The NRF has not deployed substantially as it was envisaged, as a combat-capable crisis response force. Only select supporting forces have been deployed, mainly for humanitarian missions. Not being used for what it was initially created for during the past decade, has raised different concerns and doubts about whether NRF is as useful as it was expected to be. From its establishment, NRF has only been used in non-combat operations of limited importance. The NRF was used for the very first time in 2004 to provide security during the Athens Olympics. In addition to this, NRF was used the following year in a disaster relief type mission in Louisiana after the Hurricane Katrina and Pakistan following an earthquake.⁵⁷ Based on the past NRF engagements, it can be said that NRF has not proven itself in combat even though there have been opportunities and operations when NRF could be used. The surge in Afghanistan in 2009 could have been an opportunity for the employment of NRF, but nations participating in NRF opposed that idea.⁵⁸ During this surge, an additional 30,000 U.S. troops were sent to Afghanistan, with the largest number coming from the U.S. Marine Corps, especially from the Marine Expeditionary Brigade (MEB).⁵⁹ These forces are very similar to the

⁵⁶Allied Command Operations, “The NATO Response Force,” NATO, <http://www.aco.nato.int/page349011837.aspx> (accessed 2 February 2014).

⁵⁷Lasconjarias, 1.

⁵⁸Ibid., 7.

⁵⁹Jim Garamone, “Officials Announce First Afghanistan Surge Units,” The Official Homepage of the United States Army, 8 December 2009, http://www.army.mil/article/31457/Officials_announce_first_Afghanistan_surge_units/ (accessed 25 February 2014).

NRF structure, and this would have been the right match for NRF. Operation Unified Protector over Libya also represented the type of mission typically for NRF. However, in this case, many commentators failed to mention that, at the time, the operational command in Naples was just finishing the NRF training process, which was then successfully implemented during a real life operation.⁶⁰ A frequent argument has been made that the NRF is not prepared for operations, though most of the participating countries in NRF have been part of the operations in Kosovo, Afghanistan or Libya but under a different flag and circumstances.

Being a NATO expeditionary force, NRF has the overarching purpose of being able to provide a rapid military response to an emerging crisis, whether for collective defense purposes or for other crisis response operations. It can be used as a first entry force during NATO Article 4, Article 5 or Non-Article 5 type of operations. During an Article 4 type of operation, which includes consultations between parties, when in the opinion of any of the parties, their territorial integrity, political independence, or security is threatened.⁶¹ In practice, it has rarely been used and sends a strong political message to the greater world that NATO is concerned about a particular situation. On 26 June 2012, this article was invoked by Turkey, after they shot down a Syrian aircraft that had entered Turkish airspace.⁶² The last invocation of Article 4 was by Lithuania in March 2014,

⁶⁰Lasconjarias, 7.

⁶¹NATO, *The North Atlantic Treaty*, 9 December 2008, http://www.nato.int/cps/en/natolive/official_texts_17120.htm (accessed 3 March 2014).

⁶²Robert Coalson, "What Are NATO's Articles 4 And 5?" Radio Free Europe Radio Liberty, 26 June 2012, <http://www.rferl.org/content/explainer-nato-articles-4-and-5/24626653.html> (accessed 5 March 2014).

following the Russo-Ukrainian conflict over Crimea.⁶³ Even though NRF engagement in Article 4 is unlikely, in this case NRF can be used as a show of force to deter an aggressor. Article 5 is known as the one-for-all and all-for-one article, and is the keystone of NATO as an organization. It states that an “armed attack” against one member is an attack against all and sets in motion the possibility of collective self-defense.⁶⁴ In case of an Article 5 operation, NRF will fully engage with all its components. Though Article 5 has only been invoked once,⁶⁵ immediately following the 9/11 terrorist attacks against the United States, it remains one of NATO’s key commitments. The past two decades, NATO has been primarily engaged in NA5CRO operations, from Yugoslavia to the recent ongoing operation in Afghanistan. NA5CRO refers to crisis management, which is one of NATO’s fundamental security tasks. It can involve military and non-military measures to respond to a threat, be it in a national or an international situation. A crisis can be political, military, or humanitarian, caused by political or armed conflict, technological incidents, or natural disasters.⁶⁶

Almost all of the small countries that are part of the analysis in this research, at some point have been engaged, participated and are still part of these types of NATO

⁶³Matt Ford, “Russia's Seizure of Crimea is Making Former Soviet States Nervous,” *The Atlantic*, 1 March 2014, <http://www.theatlantic.com/international/archive/2014/03/russias-seizure-of-crimea-is-making-former-soviet-states-nervous/284156/> (accessed 1 May 2014).

⁶⁴NATO, *The North Atlantic Treaty*.

⁶⁵*Ibid.*

⁶⁶NATO, “Crisis Management,” 27 October 2010, http://www.nato.int/cps/en/SID-DAFBA165-411F6D78/natolive/topics_49192.htm?bInSublanguage=true&selectedLocale=uk&submit=select (accessed 15 March 2014).

operations. Estonia, Latvia, Lithuania, Hungary, Macedonia, Albania, and Croatia have contributed to these operations with different capabilities as well as with SOF elements. Though these countries have not been operationally engaged as part of NRF, a further analysis will determine how these countries' SOF elements can contribute to NRF. It is very likely that in the future, NATO might continue to engage in NA5CRO operations, and NRF might be greatly involved.

After 2014, NATO is expected to shift its emphasis from operational engagement to operational preparedness.⁶⁷ This means NATO will need to remain capable of performing its core tasks and of maintaining its forces at a high level of readiness. In order to achieve this, allied leaders set the goal of “NATO Forces 2020.”⁶⁸ This embodies a modern tightly connected, properly equipped, well trained, and exercised. The Connected Forces Initiative has a great emphasis in achieving this goal. Through this concept, Allied and partner nations, will improve their interoperability, capability and readiness by conducting various exercises and mutual trainings. The main requirements of Connected Forces Initiative are to ensure that Allies can communicate, train, and operate together effectively, and that NATO has increasing opportunities to validate and certify their ability to do so.⁶⁹ In this regard, NRF is the flagship of implementation of the Connected Forces Initiative.

⁶⁷NATO, “The Connected Force Initiative,” 24 October 2013, http://www.nato.int/cps/en/natolive/topics_98527.htm (accessed 3 March 2014).

⁶⁸Ibid.

⁶⁹Ibid.

NRF's Training and Interoperability

NRF represents a mechanism for maintaining interoperability among its components and among the contributing nations. During the rotational circles, and the standby period, all participating nations go through different evaluations and participate in multiple NRF exercises, which improves their interoperability, and strengthens their alliance. According to its mission and core tasks NRF prepares to support NATO core tasks: Collective defense, Crisis Response and Cooperative Security. The Joint Warfare Centre provides the best training support possible for the collective training and certification of NATO's joint operational and component level Headquarters and plays a crucial role in training NATO members for ISAF duty as well as developing the capabilities and structures of the NRF.⁷⁰ The Joint Warfare Center prepares scenarios and exercises that cover Article 5 and NA5CRO type of operations. The Steadfast series of exercises were designed to ensure that NATO's Joint Force Commands and their associated components (land, maritime, special forces and air) were ready to deploy, execute and redeploy at minimum notice and achieve Alliance objectives. NRF has been actively involved in this series of exercises that has helped to evolve the NRF concept.⁷¹ Since 2008, this exercise was based on the Cerasia scenario that represented a Crisis Response Operations outside of NATO's borders, based in the Horn of Africa geographic region, to address regional tensions and humanitarian crisis. This scenario was developed

⁷⁰Joint Warfare Center, "Training," NATO, [.http://www.jwc.nato.int/activities/training](http://www.jwc.nato.int/activities/training) (accessed 20 April 2014).

⁷¹Wg Cdr Mark Attrill, GBR AF. "A JWC Support to the NATO Response Force," *The Three Swords Magazine*, no. 25 (July/October 2013): 41.

because of the NRF's real world engagement in disaster relief operations in Pakistan.⁷²

The Cerasia scenario provided NRF with exercises and prepared it for NA5CRO type of operations.

As the Cerasia scenario prepares NRF for Crisis Response operations, the newly developed scenario Skolkan, represents a NATO Article 4 and 5 type of operations, that prepares NRF for consultations and collective defense. The Skolkan Scenario is based in the geographic region of the Baltic States (Lithuania, Latvia and Estonia). This scenario introduces a new environment for NRF training, indeed, for the first time in the NRF's history, NRF was about to defend a member of the Alliance. This scenario mirrors some of the contemporary issues concerning the recent Russo Ukrainian crisis. Because of this crisis, some of the former Union of Soviet Socialist Republics countries like the Baltic States or Moldova, fear that the same crisis might spill over in their countries. The Skolkan scenario envisions very similar issues where the Alliance is threatened by an aggressive state, which is undermined by internal pro-democratic turmoil and sees dissidents in Estonia as a reason for dispute that leads to a crisis between two states. In this case, NRF is deployed in order to deter the aggression.⁷³

Small Countries' SOF Engagements within NRF

The last global economic crises that affected most of the world somewhere in 2008-2009, also impacted NATO and partner countries' budgets, which was reflected in NATO's overall performance. The vast majority of countries dipped below the level of

⁷²Attrill, 42.

⁷³Ibid.

two percent of gross domestic product for defense spending and are heading for less than that. This resulted in a lack of sufficient relevant military forces. In order to overcome the new challenging gap, in February 2010 the Secretary General of NATO launched the “Smart Defense” concept at the security conference in Munich.⁷⁴ The concept aims to deliver capabilities in a more efficient and cost-effective manner. Based on this concept, NATO will assess the capabilities shortfalls and will not require the states to prepare for the full range of contingencies, but rather to concentrate on a narrower set of deficit capabilities.⁷⁵ Simply said, the Alliance will fill in the capability gaps through the concepts of resource pooling, capabilities sharing, and niche specialization. Smart Defense, in varying degrees, requires states not to prepare for the full range of contingencies that could threaten the security of each, but rather to concentrate on a narrower set of capabilities.

The last decade of military operations in the Middle East has proven that the use of SOF, has played a significant role, and its further development is a part of the NATO Smart Defense. The proper utilization of SOF will also be a big payoff in future operations also. Since most of the small countries are unable to provide expensive and personnel-intensive support, they usually focus on developing SOF capabilities to contribute to NATO. By providing SOF, they are able to achieve more effect at a low cost. For instance, Macedonian Army SOF were formed in 1994, and from the very beginning, the focus was on developing this capability. According to the Macedonian Army White Paper, developing SOF capabilities is justified because of the evolving

⁷⁴Aronsson and O’Donnell, 46.

⁷⁵Johnson, LaBenz, and Driver, 41.

unconventional threats and the achievement of greater effect with minor forces. The investments in such units are long-term, justified, and cost-effective.⁷⁶ Estonia has also developed a very capable SOF, and contributed significantly within NATO SOF. Like Macedonia and Estonia, many other small countries focus on developing SOF elements and provide niche capability to NATO.

National SOF usually fall under the highest authorities of the political and military leadership and are used according to national policies. However, NATO faces many internal political realities such as national caveats, which limit the roles and responsibilities of certain military forces within NATO in the conduct of its missions. National caveats, resources, trained forces, and other constraints within the alliance provide fodder to critics of NATO's ability to successfully address 21st century threats. Nevertheless, these constraints are not permanent fixtures of NATO and can be remedied over time.

SOF are recognized internationally as elite warriors. Economically, SOF provides NATO and partner countries significant cost-saving benefits. SOF also communicates positive human rights and self-determination messages while fostering strong diplomatic relationships that are exceptionally durable. Traditionally SOF is utilized as a strategic asset to achieve national strategic effects. Recent combat operations by NATO members have demonstrated the synergistic effects of integrated conventional and Special Operations at the strategic, operational, and tactical levels. SOF by design plays a pivotal role in the asymmetric environment and is the force to address such threats to NATO. In

⁷⁶Ministry of Defense Republic of Macedonia, *White Paper on Defense*, September 2012, Republic of Macedonia, <http://www.morm.gov.mk/wp-content/uploads/2013/12/WHITE-PAPER-OF-DEFENCE.pdf> (accessed 20 April 2014).

these terms, smaller countries strive to develop and maintain very capable SOF capabilities. SOF provides NATO, and in this case, NRF with the appropriate tool to meet the challenges of 21st century's threats.

From the very beginning of the establishment of NATO, the United States has played pivotal role in the overall NATO collective defense and crisis response. Europe has always relied and been dependent on the United States. However, after very long engagements, and the drawdown in military spending as a result of the global crises, the United States began to decrease its contribution in Europe. NATO's and the European Union's enlargement eastwards since the end of Cold War, and the pursued partnership with Russia, receded perceived U.S military presence to defend the continent. Some allies in Central and Eastern Europe have consistently expressed concerns about the reduced U.S. force posture, and especially the recent withdrawal of two of the Army's four Brigade Combat Teams. These reductions led to calls by the United States for European Allies and the European Union to develop enhanced military capabilities in order to boost NATO's effectiveness and reduce Europe's dependence on the United States' security guarantee.⁷⁷ This new environment signals that European countries should focus on developing more robust and capable capabilities, and soften their reliance on the United States. This applies to SOF capabilities also, since they have heavily relied on support from the United States.

⁷⁷Paul Belkin, Derek E. Mix, and Steven Woehrel, Congressional Research Service Report 43478, *NATO: Response to the Crisis in Ukraine and Security Concerns in Central and Eastern Europe* (Washington, DC: Library of Congress, 16 April 2014), 15.

As earlier stated, NRF should be used as a NATO entry force in support of NATO operations. In determining ways of employment of the SOF elements from the small countries, this research proposes two military concepts in support of NATO core tasks of Collective Defense, Crisis Response and Cooperative Security: (1) joint employment under a larger NATO SOF force; and (2) joint employment as a group of small nations.

Joint Employment under a Bigger NATO SOF Force

Special operations and SOF by nature are usually joint and organized in a joint manner with aviation, naval or other forces from the contributing nations.⁷⁸ SOF provide an inherently agile instrument ideally suited for the unusual and dynamic irregular environment while allowing national and collective defense establishments to retain freedom of action through employing economy of force. SOF is characterized as strategic assets because of their ability to achieve political, military, psychological, and informational objectives that represent the foundational instruments of national power.⁷⁹ SOF operates outside the realm of conventional operations or beyond the standard capabilities of conventional forces, thus providing a solution to extraordinary circumstances of political interest when no other option is available. According to the NATO SOF doctrine, special operations embrace two approaches that are mutually supporting and complementary, the direct and indirect approach.⁸⁰ The direct approach

⁷⁸NATO, Allied Joint Publication (AJP) 3.5, *Allied Joint Doctrine for Special Operations* Edition A, Version 1 (Brussels, Belgium: NATO Standardization Agency, December 2013), 1-2.

⁷⁹NATO Special Operations Headquarters (NSHQ), *Special Operations Forces Study* (Mons, Belgium: North Atlantic Treaty Organization, December 2012), V.

⁸⁰NATO, AJP 3.5, 1-2.

applies short, sharply focused offensive action to rapidly dominate carefully chosen points of vulnerability with clarity of purpose and a clearly defined aim.⁸¹ The indirect approach orients efforts to loosen the adversary's grip by upsetting his balance, thereby setting conditions for the targeted application of the direct component.⁸² NATO SOF doctrine identifies three principle tasks: Military Assistance, Special Reconnaissance and Direct Actions.⁸³

In order to determine and analyze this model of small countries' SOF employment, the following table gives an overview of the NATO CJFSOCC Organization.

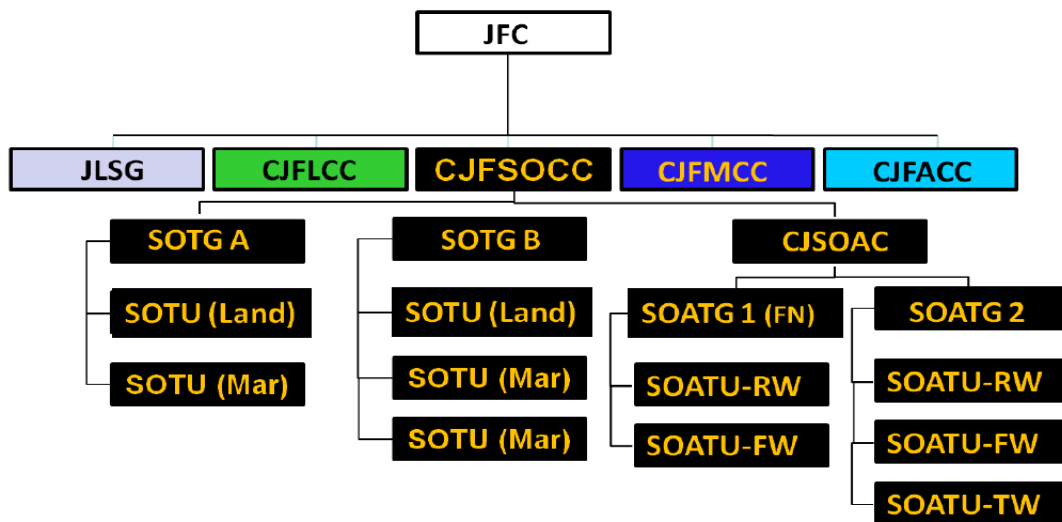

Figure 3. NATO CJFSOCC Organization

Source: NATO Special Operations Coordination Center, *SOTG MANUAL*, Version 1.0 (Mons, Belgium: North Atlantic Treaty Organization, 11 December 2009), 1-3.

⁸¹NATO, AJP 3.5, 1-2.

⁸²Ibid.

⁸³Ibid., 2-1.

CJFSOCC is a multinational, joint component command, tailored to command and control its assigned SOF and it is not standing headquarters in the NATO command structure.⁸⁴ From this structure, small countries' SOF should fit within the SOTU, which will be elaborated in depth in this chapter. SOTG is a basic type SOF element that should be able to plan and conduct Special Operations as directed by the Commander, CJFSOCC at the tactical level covering the full spectrum of special operation missions and it is usually consisted of a national grouping of land/maritime/air SOF.⁸⁵ Troop Contributing Nations, usually bigger countries, contribute SOTG elements to NATO. According to the AJP-3.5 and the SOTG manual, SOTG is comprised of:

- (1) A HQ that is capable of conducting SO1-SO6 staff functions.
- (2) Subordinate SOTUs.
- (3) Combat Support (CS) units.
- (4) CSS elements.⁸⁶

The following figure depicts the size of the SOTG by elements.

⁸⁴NATO, Allied Joint Publication 3 (B), *Allied Joint Doctrine for the Conduct of Operations* (Brussels, Belgium: Military Agency for Standardization, March 2011), 1-10.

⁸⁵*Ibid.*, 1-6.

⁸⁶*Ibid.*

Table 1. Example of SOTG Manning

<u>ELEMENT</u>	<u>MANNING</u>	<u>NUMBER</u>	<u>TOTAL PAX</u>
COMMAND GROUP	19	1	19
SOLTU (LAND)	16	2	38
SOMTU (MARITIME)	16	1	16
SOATU (AIR)	8 (1xFixed-, Rotary-, & Tilt-Wing)	1	8
TOTAL SOF OPERATORS			81
COMBAT SUPPORT	15	1	15
COMBAT SERVICE SUPPORT	10 (30 with security attachment)	1	10/30
TOTAL SUPPORT PAX			25/45
TOTAL FORCE	Additional personnel for INT support		106/126

Source: NATO Special Operations Coordination Center, *SOTG MANUAL*, Version 1.0 (Mons, Belgium: North Atlantic Treaty Organization, 11 December 2009), 1-14.

According to the overall size of a SOTG (106/126) and the elements of which an SOTG is consisted, small countries are not able to contribute that much of a SOF element. Even though some of the small countries, such as Lithuania, Estonia, Bulgaria, and Hungary⁸⁷ possess very capable SOF, they are contributing up to a SOF team sized element to NATO.⁸⁸

SOTG is a self-sustaining, national grouping of land and/or maritime SOF, in principle generated from a single nation; however it can also be combined, under a single

⁸⁷Hungarian Government, “HDF Special Operations Team,” Hungarian Government Website, <http://www.kormany.hu/en/hungary-in-afghanistan/about-our-teams-and-contingents/hdf-special-operations-team> (accessed 1 April 2014).

⁸⁸Gompert and Smith, 3.

commander.⁸⁹ Within the first concept mentioned earlier, small countries' SOF will best fit within this structure as a SOTU element under a bigger Troop Contribution Nation SOF combined SOTG. In this case, smaller countries should contribute a SOTU element. In order to further refine and differentiate capabilities, as well as acknowledge variations among different nations SOTU, the NATO Special Operations Headquarters (NSHQ) SOF study, identifies two types of SOTU, SOTU (A) and (B).⁹⁰ SOTU (A) represents a SOF tactical unit manned with between 8-24 SOF personnel, and SOTU (B) manned between 24-60 SOF personnel.⁹¹ This size of a SOF element corresponds with the size that most of the smaller countries have contributed in past years in the NATO led operations, particularly within NATO SOF. However, those SOF elements have not been employed as part of this kind of framework. Capabilities needed for these types of SOF elements will be discussed later in this chapter.

Similar to this framework, in the article "Creating a NATO Special Operations Force," David C. Gompert and Raymond C. Smith propose a model for NATO SOF, where they argue that within the inner core of SOF structure smaller nations should participate with no larger than a 50-person force or roughly an assault team equivalent. This force is proposed as a three-month, rotational-framework nation iteration that in the case of this research corresponds with the NRF rotations but in a shorter period of time. The authors in this article also argue that for smaller nations, this may represent a

⁸⁹NATO, AJP 3.5, 3-4.

⁹⁰NSHQ, *Special Operations Forces Study*, annex C, C-7.

⁹¹*Ibid.*

significant percentage of their overall organic capability, with an entry cost perhaps too high for smaller, less mature SOF capabilities to overcome.⁹²

In this concept of combined SOTG, small countries' SOF would be under operational control to the Troop Contributing Nation (TCN) SOTG. Following the past achievements and contribution to NATO SOF, some of the larger NATO countries such as Romania, Poland, Germany, Norway and most noticeably the United States, had played a major role in the ISAF in Afghanistan. These countries' SOF represents a mature and very capable SOF capability and has contributed SOTG elements to NATO SOF. Romania and Poland, as one of the biggest contributors to NATO SOF operations, partnering with U.S. SOF, have significantly improved their SOF capabilities and also have proven as very close supporters of the U.S. SOF engagements in Afghanistan. Both Romania and Poland, in 2007-2008 and beyond, have committed SOTG with two to three SOTU elements as part of the ISAF.⁹³ As a combined SOTG, this concept proposes small countries to pledge SOTU (A) or (B) to a SOTG from other larger and more mature SOTG elements, like Romania, Poland, Germany, or the United States. As a part of a combined SOTG, all subordinate SOTU should be able to execute all primary NATO SOF tasks: Military Assistance, Special Reconnaissance, and Direct Actions in support of NATO core tasks: Collective defense, Crisis management and Cooperative security. As a part of a mature and more capable SOF element, small countries' SOF can also improve their capabilities and continue developing national SOF elements. In the case of Romania

⁹²Gompert and Smith, 6.

⁹³LtCol Buck Dellinger, "Strengthening Partnerships for Global Security," *Special Warfare* (April-June 2012), <http://www.soc.mil/swcs/SWmag/archive/SW2502/SW2502SpecialOperationsCommandEurope.html> (accessed 15 April 2014).

and Poland, their partnership with U.S. SOF as part of ISAF and the Provincial Response Company missions, have greatly improved their capability.⁹⁴ Similar to this, small countries' SOF would also be able to improve and conduct their missions more effectively by working together with a larger and more mature partner. To better understand and analyze any gaps in this model, DOTMLPFI⁹⁵ can be a useful tool.

Doctrine

The establishment of NATO Special Operations Headquarters in 2010 solved most of the existing gaps within the NATO SOF community. It is responsible for comprehensive NATO SOF policy, doctrines, standards, education, and assessments. Allied Joint Publication 3.5, *Allied Joint Doctrine*, is the NATO SOF current doctrine and it applies to all NATO and partner countries. NATO Special Operations Headquarters has published many other documents relating to NATO SOF. The *NATO Special Operations Forces Study* published in 2008, the *Special Operations Task Group (SOTG) Manual* and the *Combined/Joint Forces Special Operations Component Commander (CJFSOCC) Manual* give a theoretical overview to structure forces for enhanced integration while emphasizing that national SOF forces should primarily structure their forces to meet national military objectives. Even though some of the countries have their own doctrine, as NATO members, or NATO partner countries, current NATO SOF doctrine have to be common to all. Regarding the first concept, small

⁹⁴Dellinger.

⁹⁵DOTMLPFI is a problem-solving construct used by the U.S. Department of Defense for assessing current capabilities and managing change. DOTMLPFI is defined in the Joint Capabilities Integration and Development System. NATO has added an additional "I" to the acronym that has to do with Interoperability.

countries' SOF partnering with a larger NATO SOF will utilize current NATO SOF doctrine during their joint training, cooperation and deployment. The larger and more mature SOF element should help smaller countries to improve their capability and standardize their Tactics, Techniques, and Procedures.

Organization

As analyzed earlier, small countries in both of the proposed models should contribute with a SOLTU (Special Operations Land Task Unit) element, (A) or (B) size. Table 1 explains SOTG's structure, where apart from SOLTU there are maritime and air elements. Based on the expenditures that air and maritime elements require, small countries should focus on contributing land elements, respectively SOLTU. The bigger superior nation should provide the rest of the elements, or they can be required from a higher command from the chain of command.

Training

Initially, training should be conducted based on the NATO SOF doctrine with the national SOF training process, following further joint trainings and exercises with the rest of the partners and Allies. Training should cover all three core NATO SOF tasks: Military Assistance, Direct Actions and Special Reconnaissance. The Jackal Stone exercise serves as a bedrock designed to build special operations capabilities and improve interoperability among European partner nations. In Jackal Stone 2012, Army Major General Michael S. Repass, Commander of Special Operations Command Europe stated that the basic premise is to leverage each other's capabilities to build stronger teams to serve in a coalition or NATO operation, and the significance of teaming up with another

capable partner.⁹⁶ Exercise Jackal Stone is an annual event and it is hosted each year by different countries. Beginning in 2007 when the exercise actually was renamed to its present code name, all of the countries mentioned earlier in this research have participated and continue to participate.⁹⁷ Another element that provides comprehensive SOF training is the NATO SOF School at the NATO Special Operations Headquarters located at Supreme Headquarters Allied Powers Europe in Belgium. The NATO SOF School's mission is to improve interoperability, capability, effectiveness of Allied, and partner SOF through precise yet flexible training and education, tailored to meet the dynamic requirements of NATO's elite special operations professionals.⁹⁸ Another method to improve training in this concept is the U.S. Joint Combined Exchange Training model. The Joint Combined Exchange Training model is a joint exercise program utilized extensively by SOF. The Joint Combined Exchange Training model is a means by which SOF maintain their combat readiness and at the same time participate in theater security cooperation strategy. This concept provides training opportunities and increases cooperation for U.S. SOF with Allies and partners.⁹⁹ Similarly, to this program of

⁹⁶Donna Miles, "Jackal Stone Promotes Special Operations Partnership," 18 September 2012, U.S. Department of Defense, <http://www.defense.gov/news/newsarticle.aspx?id=117917> (accessed 20 March 2014).

⁹⁷United States European Command, "Exercise Jackal Stone," <http://www.eucom.mil/key-activities/exercises-and-operations/exercise-jackal-stone> (accessed 25 April 2014).

⁹⁸NSHQ, "NATO SOF Professional Military Education," <https://www.nshq.nato.int/nsos/> (accessed 20 March 2014).

⁹⁹United States Army Combined Arms Center, "Joint Combined Exchange Training," 17 September 2008, <http://usacac.army.mil/cac2/call/thesaurus/toc.asp?id=34288> (accessed 15 April 2014).

exercises, the larger country that will be the lead can conduct trainings with the smaller countries with which they will form a combined SOTG.

Materiel

Based on the SOLTU capability requirements, the basic material (individual equipment, weapons, ammunition) support falls under the Troops Contributing Union. One of the elements that one SOTG should be capable of is to provide combat support and combat service support functions to support assigned and attached SOTUs.¹⁰⁰ Based on this, small countries' SOLTU will rely on support from the SOTG. The remainder of the larger material and transportation means, such as helicopters or other type of vehicles, can be provided by the higher command. This has also been the case in the previous engagements where smaller nations had relied on a higher support. The leading country should be able to provide the small countries' SOLTU with the needed material that they do not possess.

Leadership

The leadership will be assumed by the nation contributing SOTG. In the case of a combined SOTG, there will be one commander,¹⁰¹ and in this model, the nation that provides the SOTG will provide the leadership.

¹⁰⁰NATO Special Operations Coordination Center, *SOTG MANUAL*, 1-6.

¹⁰¹Ibid.

Personnel

In this model, small countries would contribute either SOLTU (A) or (B). The size of these units ranges from 8-24 SOF personnel for SOLTU (A) and 24-60 for SOLTU (B).¹⁰²

Facilities

This deals with the facilities that SOF will utilize as part of their training, pre-deployment process, and during deployments. Training and pre-deployment can be a combination of different training facilities in each of the participant countries. The host nation of any of these mutual trainings is usually the one that will provide the greatest piece. During deployments, depending on the deployment framework, facilities will fall under the higher command.

Interoperability

In a combined SOF unit and a mixture of different nations, interoperability is a key component of success. Beginning with the common language to all, through Tactics Techniques and Procedures and doctrine, up to weapons and other communication systems, all nations should be interoperable. However, the Communication and Information System is the nerve system of SOF. The Communication and Information System CIS should be interoperable at the appropriate security level with the Communication and Information System deployed by SOF of all services from the different TCNs, and they should integrate not only with state-of-the-art systems, but also

¹⁰²NSHQ, *Special Operations Forces Study*, C-7.

should be capable of integrating with less sophisticated equipment.¹⁰³ In this regard, NATO SOF doctrine covers most of the interoperability gaps; however, joint exercises and pre-deployment trainings are the best mechanism to improve interoperability and spot any gaps. NRF exercises, NATO SOF exercise Jackal Stone, or any other multinational SOF exercises are the bedrocks for interoperability. However, in the first model, small countries' SOLTU should work closely with the SOTG to achieve standardization, build up mutual trust, and improve interoperability.

Joint Employment as a Regional Group of Small Nations

The first concept described provided an overview of SOF employment that to a certain extent has similarities with past joint SOF engagements that have proven to be very successful over the past decade. Being under the umbrella of a bigger and mature force eases most of the difficulties smaller countries face regarding the sufficient training and combat support. The second concept basically proposes formation of a SOF element, SOTG size, from different smaller nations, all of them contributing SOTU size elements. Combined SOTGs will only be authorized when an appropriate level of combined training has been achieved and with the approval of the Framework Nation and the Supreme Allied Commander Europe.¹⁰⁴ In order to understand this concept, and the challenges it might present, an overview of the B-9 concept and Baltic States Special Operation Forces will give a thorough understanding.

¹⁰³NATO Special Operations Coordination Center, *SOTG MANUAL*, 1-16.

¹⁰⁴*Ibid.*, 1-6.

B-9 represents a multinational military joint cooperation between the Balkan countries initiated by the Chiefs of Staff of the Balkan countries.¹⁰⁵ Within the B-9 framework are included Albania (NATO member), Greece (NATO member), Romania (NATO member), Turkey (NATO member), Bulgaria (NATO member), Croatia (NATO member), Macedonia, Serbia, and Montenegro. This cooperation represents a mixture of NATO and partner countries. Within the B-9 concept, a great emphasis is put in developing a mutual SOF capability able to contribute to greater security in the region.¹⁰⁶ Similar to the Jackal Stone exercise that is coordinated by the United States through Special Operations Command Europe and is primarily a partnership building exercise,¹⁰⁷ B-9 countries annually perform SOF exercises in one of the participating countries with the same end-state. Its objective is to provide special operations forces the opportunity to train together and build mutual respect with each other while sharing doctrinal concepts, training concepts and various Tactics, Techniques and Procedures. The last B-9 SOF exercise took place in Serbia in 2013 under the code name “Eagle 2013.”¹⁰⁸ Participating countries in B-9 usually contribute with assault team element or equivalent to Operational

¹⁰⁵Ministry of National Defence Republic of Macedonia, “SOR Participation in Exercise B-9 in Republic of Serbia,” 30 October 2013, http://www.arm.mil.mk/vesti/pocetna/2013/10/en_vezba_pso.html (accessed 12 March 2014).

¹⁰⁶Balkan Security Agenda, “International Special Forces Exercise ‘Eagle 2013’ Completed,” <http://www.balsec.org/policy-areas/defence-and-security/international-special-forces-exercise-eagle-2013-completed/> (accessed 12 April 2014).

¹⁰⁷United States European Command, “Exercise Jackal Stone.”

¹⁰⁸Balkan Security Agenda, “International Special Forces Exercise ‘Eagle 2013’ Completed.”

Detachment Alpha or SOLTU (A), and the total number of troops reaches up to a SOTG size, more than 100 personnel.¹⁰⁹

The Baltic States Special Operations Forces also represents an excellent example of smaller countries' cooperation and creation of a mutual SOF capability. Lithuania, Latvia, and Estonia, all of them NATO members, understanding the benefits of having a capable SOF element, have increased their military cooperation especially in the SOF domain. On 2 December 2011, the defense ministers of Lithuania, Latvia, and Estonia announced new defense cooperation initiatives designed to increase and enhance military cooperation among them. One of the initiatives proposes collective formation of contingents for standby in the NRF and expressed their support for closer cooperation between the SOF of these countries.¹¹⁰ Both decisions represent very positive steps forward in building a regional military capability that more or less corresponds with the B-9 cooperation within the Balkan countries. Besides having larger and more capable SOF, building a collective SOF capacity could serve as the initial step in resource sharing and unnecessary spending.

As described in the first concept where the smaller countries' SOF will fall under a larger country SOF SOTG; in this concept, different smaller countries' SOF, similar to the B-9 concept or the Baltic States Special Operations Forces, can contribute up to a SOTU element and form a combined SOTG that can be pledged as a contributing SOF

¹⁰⁹Balkan Security Agenda, "International Special Forces Exercise 'Eagle 2013' Completed."

¹¹⁰Ministry of National Defence Republic of Lithuania, "Baltic Defense Ministers Announced New Defense Cooperation Initiatives," http://www.kam.lt/en/news_1098/current_issues/baltic_defence_ministers_announced_new_defence_cooperation_initiatives.html (accessed 10 April 2014).

element within NATO SOF. Almost all of the above mentioned countries, have contributed SOTU size elements under NATO command in Afghanistan or Iraq, and to a certain extent have gained the needed proficiency. However, due to the diversity of the different nations' SOF, this model might be more challenging.

Another good example of a regional SOF cooperation is the Combined Task Force 77, composed of highly trained Lithuanian and Latvian SOF. Both Baltic countries have teamed together and contributed SOF capability to the ISAF. This Task Force has been providing military assistance to Afghan special police forces, while also conducting direct action and special reconnaissance missions. Combined Task Force 77 has been working with aviation brigades in Regional Command-South since 2010.¹¹¹ As the United States is downsizing its contribution to Europe, and larger European/NATO countries are becoming exhausted after the last decade of involvement in Afghanistan and Iraq, this type of model of regional cooperation should be taken in to consideration. As in the first concept, DOTMLPFI will also be used for analysis.

Doctrine

As in the first concept, the same NATO SOF doctrine will apply to all of the small countries. Though some of the countries have developed their doctrine, the core is based on the current NATO SOF doctrine. However, when all these small countries will collaborate and work together, a common doctrine will have to be used. The best way to improve their performance is to standardize their procedures through various joint

¹¹¹Afghanistan International Security Assistance Force, "Delivering CTF 77 to the Fight," NATO, <http://www.isaf.nato.int/article/news/delivering-ctf-77-to-the-fight.html> (accessed 20 April 2014).

exercises and pre-deployment training. The diversity of all the countries that will decide to team up is challenging. Sharing the lessons-learned from the previous deployments and continuous cooperation will lessen those challenges.

Organization

As in the first model, this model proposes that small countries should contribute a SOLTU element, (A) or (B) size. The difference from the first model is that now small countries should form a complete SOTG with all of its components.¹¹² As discussed in the first model, where most of the SOTU's air and maritime will be provided by the larger NATO SOF force, in this case, these capabilities should be provided by the smaller countries. The best way to develop those capabilities is by developing niche capability for air or maritime from some of the countries that are more capable.

Training

No shortcut exists to develop SOF when crises arise or when SOF are needed. Years of training, education and experience acquired through an investment in time and resources are necessary to prepare SOF to be able to execute special operations.¹¹³ Training should cover all three core NATO SOF tasks: Military Assistance, Direct Actions and Special Reconnaissance. The initial training will bring SOF to a level capable of successfully conducting special operations. Once that level is reached, mutual training and different joint exercises will improve the overall capability and performance of the contributing countries. As stated earlier, Jackal Stone, B-9 joint exercises, or any

¹¹²Refer to table 1, SOTG Organization.

¹¹³NSHQ, *Special Operations Forces Study*, IV.

other similar type of cooperation will improve the training of all countries that will form the combined SOTG.

Materiel

Based on the SOLTU capability requirements, the basic material (individual equipment, weapons, ammunition) support falls under the TCN. SOTG should be able to deploy with a minimum of 10 days of all classes of supply necessary to sustain the SOTG headquarters and assigned task units.¹¹⁴ SOF missions could require joint logistic planning and execution. When the SOTG TCN cannot satisfy its SOF support requirements, and in this case the TCN of the SOTU's, the Joint Force Command, through CJFSOCC will determine if it can satisfy the requirement through common or joint servicing arrangements.¹¹⁵ This has also been the case in the previous engagements where smaller nations had relied on a higher support. Cooperation of Combined Task Force 77 with 25th Combat Aviation Brigade, 2nd Battalion of the 25th Aviation Regiment in Afghanistan, is a good example of how higher command provides support to smaller countries and its subordinates. 2/25th Combat Aviation Brigade provided air support and air mobility to Combined Task Force 77 allowing them to react and move quickly across Kabul province.¹¹⁶

¹¹⁴NATO Special Operations Coordination Center, *SOTG MANUAL*, 8-1.

¹¹⁵*Ibid.*, 9-3.

¹¹⁶Afghanistan International Security Assistance Force, "Delivering CTF 77 to the Fight."

Leadership

In the second model, where almost all of the participating countries will have the same size element, leadership can be established on a rotational basis. Namely, nations will take lead on that particular SOTG as they go on rotations or stand by period. Good example of nations taking a lead is the Combined Endeavor exercise in 2011, where Lithuania was the leading nation.¹¹⁷ However, NRF's rotations and stand by periods can be an excellent example of nations taking lead on rotational basis, where each of the nations can take lead during a particular rotation.

Personnel

As in the first model, countries would contribute either SOTU (A) or (B) that range from 8-24 SOF personnel for SOTU (A) and 24-60 for SOTU (B).¹¹⁸ Depending on their capabilities and the size of their national SOF, countries will decide which type they can pledge.

Facilities

Training and pre-deployment training can be a combination of different training facilities in each of the participant countries. Allocation of the facilities between countries can be cost beneficial and provide diversity of training environments. The host nation of any of these mutual trainings is usually the one that will provide the greatest

¹¹⁷United States European Command, "Lithuania Takes Lead at Combined Endeavor," 19 September 2011, <http://www.eucom.mil/article/22592/lithuania-takes-lead-at-combined-endeavor> (accessed 4 April 2014).

¹¹⁸NSHQ, *Special Operations Forces Study*, C-7.

piece. During deployments, depending on the deployment framework, facilities will fall under the higher command.

Interoperability

In a combined SOF unit and a mixture of different nations, interoperability is a key component of success. Starting from the common language to all, through Tactics Techniques and Procedures and doctrine, up to weapons and other communication systems, all nations should be interoperable. It is imperative, that the diversity between nations does not interfere with the fulfillment of the mission. Countries should be able to understand, train, work, and deploy together. One big issue is the equipment and procedures in conducting operations. Standardizations should be made before these countries begin to work together. Communication Information Systems and procedures are a crucial element and a very important issue that needs to be standardized in order to be able to talk together. In this regard, NATO SOF doctrine covers most of the interoperability gaps, however, joint exercises and pre-deployment trainings are the best mechanism to improve interoperability.

NATO SOF Requirements

Every nation that will contribute a SOF element to NATO must determine which national special organization best suits its national requirements for SOF. Since two models of employment of small countries' SOF within a combined SOTG were discussed earlier, this section will discuss requirements needed to contribute SOTG and SOLTU elements to NATO.

The NATO SOF core element within the CJFSOCC is SOTG. The NATO Special Operations Headquarters *NATO SOF Study* from 2012 identifies the following minimum capabilities for a SOTG with its subordinate SOTU:

1. Conduct J1-J6 staff functions
2. Plan, coordinate and direct special operations separately or as part of a larger force
3. Command subordinate SOTUs, CS units and CSS units
4. Maintain OPSEC, to include restrictive OPSEC procedures involving sensitive or compartmented SOF operations.
5. Manage force protection for the SOCCE headquarters, as required
6. Deploy within established deployment timelines with all classes of supply to sustain itself for 10 days.
7. Sustain itself once deployed with its organic CSS capability via host nation support (HNS) agreements and/or tailored national support arrangements.
8. Establish liaison element on the appropriate level to provide advice, coordination, and staff assistance on the employment of SOF to superior SOF and/or conventional headquarters.
9. Provide augmentation to superior SOF and/or conventional headquarters.
10. Perform all-source intelligence analysis and fusion.
11. Disseminate tactical intelligence.
12. Incorporate intelligence products into mission planning.
13. Conduct surveillance of a target using UAVs.
14. Conduct chemical, biological, radiological, nuclear (CBRN) reconnaissance using accredited metering systems.
15. Conduct tactical signal intelligence (SIGINT) gathering operations.
16. Provide SOF teams with an embedded language capability to train and advise and/or employ with national military or paramilitary forces.
17. Provide organic powered vehicle mobility.¹¹⁹

Concerning the first model proposed in this research, the larger NATO SOF force that will contribute the SOTG should fulfill the above-mentioned criteria. The above-mentioned capabilities are the minimum requirements that countries should meet or they should develop the ones they are lacking. In the second model where small countries will form a combined SOTG, these capabilities and requirements should be allocated between all the countries that will form the SOTG. By developing niche capability from each of

¹¹⁹NSHQ, *Special Operations Forces Study*, annex C.

the countries, these requirements can be met easily. It is imperative that once an agreement to form this kind of SOTG is reached, participating countries should start developing some of these capabilities based on resources they possess. Some of these countries have already developed most of these capabilities, or they are still developing them. Due to the sensitivity and classification of these documents, exact data on what they have developed cannot be provided in this research.

The same NATO SOF study identifies capabilities and requirements for the SOLTU. SOLTU is the lowest level of a SOF tactical-level combat element that forms a SOTG and can deploy by air, land, or sea and is able to conduct Military Assistance, Special Reconnaissance, or Direct Actions. A SOLTU, depending on actual strength, may be capable of split-team operations.¹²⁰ All SOLTU should have the following minimum capabilities:

1. Plan and conduct special operations missions in hostile, denied, or politically sensitive areas, separately or as part of a larger force.
2. Deploy within established deployment timelines with all classes of supply to sustain itself for at least 10 days.
3. Infiltrate and exfiltrate specified operational areas by air, land or sea.
4. Conduct operations in remote areas and hostile environments for extended periods (minimum of 5 days) with minimal external support.
5. Develop, organize, equip, train, and advise or direct host nation military or paramilitary forces. Teams will have an embedded language capability.
6. Conduct optical surveillance of targets by day reconnaissance/establish landing sites and coordination points.
7. Conduct optical surveillance of a target by day and night.
8. Conduct surveillance of a target using remote sensors and optics.
9. Conduct surveillance of a target using unmanned aerial vehicles (UAVs).
10. Conduct chemical, biological, radiological, nuclear (CBRN) reconnaissance using accredited metering systems.
11. Conduct signal intelligence (SIGINT) gathering operations.
12. Conduct surveillance operations by foot and vehicle.

¹²⁰NATO, AJP 3.5, 3-5.

13. Conduct patrol/section/squad level limited stand-off attack using sniper and man-pack explosive devices employed delayed fuse systems.
14. Conduct troop/platoon level maneuver operations using integral tactical mobility and support weapons.
15. Conduct squadron/company level maneuver operations using integral tactical mobility and support weapons.
16. Conduct air terminal control tasks.
17. Direct and/or effect terminal guidance control of precision guided munitions.
18. Incorporate intelligence products into mission planning.
19. Provide organic powered vehicle mobility.¹²¹

As stated earlier, Lithuania, Latvia, Estonia, Croatia, Macedonia, Hungary have contributed SOLTU elements and have been deployed to Iraq and Afghanistan conducting Special Operations under the command of a larger country SOF element. Nevertheless, the second model as a more challenging model will require that small countries be able to meet all of the above-mentioned capabilities in order to fill all the gaps the larger NATO SOF forces usually cover.

Despite the minimum capabilities required for SOTG and SOLTU, the *NATO SOF Study* and identifies four capability levels for NATO SOF:

- (1) **Level IV.** Effective and deployable tactical capability to perform all three NATO SOF mission sets (SR, DA, and MA) and proficient in the sustainment and C2 of multiple Special Operations Task Groups (SOTGs) and Special Operations Air Task Groups (SOATGs) in a complex, dynamic coalition environment. Able to establish a Combined Joint Force Special Operations Component Command (CJFSOCC) and provide tactical SOF enablers (see Annex A).
- (2) **Level III.** Effective and deployable tactical capability to perform all three NATO SOF mission sets, but limited sustainment or C2 capability.
 - (a) Manning restricts ability to sustain or control multiple SOTGs and SOATGs.
 - (b) Has manpower, equipment, and training to control multiple SOTGs and SOATGs, but is untested or requires additional refinement of coalition processes.

¹²¹NSHQ, *Special Operations Forces Study*, C-6 to C-7.

- (c) Effective in certain NATO SOF missions, but not proficient in others (e.g. proficient in DA but only limited proficiency in MA).
- (3) **Level II.** Minimally effective and deployable tactical capability to perform some but not all NATO SOF mission sets (e.g. SR and DA but not MA).
 - (a) Possess ground, maritime, or aviation SOF units.
 - (b) Significant limits to deployability.
 - (c) Not tactically proven, but some NATO SOF units (e.g. NOR) has good tactical ability, but:
 - 1) Limited C2 (e.g. manning, training, equipment).
 - 2) Limited ability to project forces beyond own borders.
 - 3) Lacks basic enablers to operate in coalition operations (e.g. language limitations, commonality of vehicles/communications).
 - 4) Has not previously operated in combined operations.
 - (d) Unable to sustain forces (i.e. unable to provide multiple coalition rotations without extended force regeneration efforts at home; lacks coherent plan to maintain force levels).
- (4) **Level I** – Nascent SOF or no true SOF units. Requires a high investment of time and resources to achieve Level II capability.¹²²

These four levels depict a comprehensive set of capabilities under which NATO SOF might fall. Of all four levels, Level III and Level IV appear to be very demanding and costly, but also require a more robust SOF, which indicates that small countries may or may not be able to develop these capabilities. A good indicator for this is the following chart that shows the budget of some of these countries and their defense budget.

¹²²NSHQ, *Special Operations Forces Study*, annex C, C-1.

Table 2. Defense Budget

	Country	Army size	Defense budget 2013	Defense % spending's of GDP
1	Hungary	10,300	\$1.1 billion	0.8
2	Estonia	5.300	\$480 million	2.0
3	Latvia	1.250	\$300 million	1.0
4	Lithuania	7.350	\$355 million	0.8
5	Croatia	12.500	\$840 million	1.41
6	Albania	14.500	\$ 300 million	1.51
7	Macedonia	8.000	\$134 million	1.4

Source: Created by author using information from International Institute for Strategic Studies, *The Military Balance 2014*, <http://www.iiss.org/en/publications/military-s-balance> (accessed 20 April 2014).

Providing Niche Support to NATO

NRF as a concept, despite the fact that it represents a new tool for NATO transformation and a tool to meet the future NATO challenges, also embodies a concept for developing niche capabilities. NATO and the United States are actively pushing development of the so-called niche capabilities in order to fill in the Alliances' capabilities gaps. The Merriam Webster dictionary defines niche as a job, activity, etc., that is very suitable for someone.¹²³ J. Moroney, A. Grissom, and J. Marquis in the book, *A Capabilities-Based Strategy for Army Security Cooperation*, published by RAND Arroyo Center, define the niche capabilities as those in which the Army has decided not

¹²³Merriam-Webster, "Niche," <http://www.merriam-webster.com/> (accessed 16 April 2014).

to invest, but which are nevertheless potentially important to the Army's effectiveness in a future contingency and cost-effective to develop in non-core partner armies.¹²⁴ Simply put, instead of trying to develop capabilities in all segments of their militaries, countries would specialize on only one or few capabilities, and those capabilities can pledge to NATO. Development of niche capabilities lessens countries' expense, especially smaller countries. The established alliance goal is for member states to spend at least two percent of Gross Domestic Product on defense. However, for European states, especially after the 2008 economic crisis that affected European countries, the actual spending has dropped to an average of 1.6 percent, with a large number of Allies spending closer to one percent.¹²⁵ Some of the small countries, like Lithuania, Latvia, or Hungary have dropped their budget even below one percent of their Gross Domestic Product.¹²⁶ This has resulted in an Alliance continually marked by capability shortfalls and a chronic reliance on the United States to fill critical gaps. The Smart Defense concept that in 2010 was launched by NATO Secretary General Anders F. Rasmussen, in varying degrees, requires states not to prepare for the full range of contingencies that could threaten the security of each, but rather to concentrate on a narrower set of capabilities. This concept proposed that it would not be individual states but NATO, as a collective Alliance, that would be capable of defending nations across the full range of potential threats.¹²⁷ Smart Defense tries to

¹²⁴Moroney, Grissom, and Marquis, 13.

¹²⁵Aronsson and O'Donnell, 9.

¹²⁶International Institute for Strategic Studies, *The Military Balance 2014*, <http://www.iiss.org/en/publications/military-s-balance> (accessed 20 April 2014).

¹²⁷Johnson, LaBenz, and Driver, 41.

build greater security with fewer resources but more coordination and coherence.

Benelux (Belgium, Netherlands, and Luxembourg) Deployable Air Task Force, the Strategic Airlift Capability, the NATO Airborne Early Warning and Control program, and NATO SOF, represent some of the existing examples of multinational-capability collaboration that can offer useful insight.

Developing SOF capabilities is a necessity to face the challenges of the 21st century. SOF is the best mechanism to fight the growth of global terrorism and the non-state actors. NATO and partner countries should perform a cost benefit analysis and examine the relative utility offered by a fully resourced SOF organization in comparison to other allocations of defense budget resources. A small first-class SOF force possessing the appropriate level of skills, capabilities, and experience is preferable to a larger force of inferior quality and requires a relatively minor expenditure of total defense costs.¹²⁸ An investment of approximately €13 million could completely outfit a 110-man land oriented SOF company/squadron sized organization with equipment including vehicular mobility, communications, computers, weapons, night vision, surveillance optics, and various other specialty equipment. Compared to the cost of only one Eurofighter that costs €77 million or an NH-90 helicopter that costs €16 million, developing a company size SOF is much more beneficial. The amount of €13 million, using the 2007 defense expenditures is five percent of the Estonian defense budget, three percent of the Latvian and Lithuanian, and one percent of the Hungarian defense budget.¹²⁹ In this regard, especially for smaller countries, developing SOF niche capability is the best match.

¹²⁸NSHQ, *Special Operations Forces Study*, 30.

¹²⁹*Ibid.*, 31.

In both proposed concepts for small countries' contribution to NRF, countries will provide SOF niche capability, SOLTU. These capabilities will have to meet the criteria needed for Level II from the capability levels for NATO SOF. However, since the niche capability concept envisions acquiring capabilities from partners that possess them, it also envisions helping developing them. In this regard, even if some of the small countries cannot manage to develop the appropriate SOF niche capability, another NATO member can help develop them.

Providing niche support has its own risk and this risk is even greater concerning a SOF niche capability. Countries that usually decide to provide niche capabilities to the Alliance have to analyze and determine which element of their force will best fill the capability gap. One of the emerging risks is whether that capability can be developed completely and whether that capability can be maintained after its development. This risk is tied to the expense needed for developing and maintaining that capability. With the smaller states with limited resources and size of the forces, the biggest risk of providing SOF niche capability is the internal security. Most of the smaller countries focus on providing SOF capabilities as niche support because they can easily maintain them. On the other hand, these countries might lack forces for their internal need. For instance, Estonia has developed SOTG SOF, after the latest transformation in 2012 and since then has actively participated with a SOTU element in Afghanistan on a rotational basis.¹³⁰ Albania and Croatia, upon their admission into the Alliance, in addition to some other forces, decided to develop SOF niche capability, and both countries planned to have eight

¹³⁰Estonian Defense Forces, "Special Operations," 11 March 2014, <http://www.mil.ee/en/defence-forces/special-operations> (accessed 26 April 2014).

percent of their force deployed and 40 percent on a standby mode for international deployments. Macedonia as a NATO partner country, developed SOF niche capability, and was deploying a 77-strong special operations unit in Baghdad as part of U.S.-led operations in Iraq for NATO.¹³¹ These small countries have been contributing a great amount of their SOF capabilities in a rotational cycle. With this being the case, contributing SOF niche capability, poses risks concerning the countries' internal utilization.

¹³¹Vincent Morelli, Carl Ek, Paul Belkin, Steve Woerhel, and Jim Nichol, Congressional Research Service Report RL 34701, *NATO Enlargement: Albania, Croatia, and Possible Future Candidates*, Federation of American Scientists, 14 April 2009, <http://www.fas.org/sgp/crs/row/RL34701.pdf> (accessed 28 April 2014).

CHAPTER 5

CONCLUSION AND RECOMMENDATIONS

The previous chapter provided findings and analysis for answering the primary and secondary research questions. This chapter is organized in three parts that provide a summary of the research. The first section covers the conclusions on NRF and its role in the future. The second part discusses the conclusions of the two developed concepts. The third section covers the conclusions on the risk of providing niche capabilities. The conclusion of this chapter provides the recommendations.

The new security environment and the threats of the 21st century changed the perception and the focus of NATO. Since its formation, NATO has gone through several transformations in order to be able to respond to the evolving challenges and to remain a credible world power. At the Washington summit in 1999, it was stated that NATO's core strategic purposes are to safeguard its members by political and military means, preserve the transatlantic link that binds the U.S and Europe, and maintain Alliance cohesion and unity so that all members are protected equally.¹³² However, the current financial austerity has forced NATO members and allies to drop their defense budgets that has resulted in degrading NATO's overall readiness and capability to meet the challenges of the new era. Another major issue to NATO has been the force generation, and the heavily reliance on support from the United States.

The formation of NRF in 2002 appeared to ease some of the above-mentioned concerns. Even though to the present, NRF has not been used in combat operations, its

¹³²NATO, "The Washington Summit."

formation proved a very successful tool for NATO transformation. NRF as a NATO expeditionary asset is capable of responding to the current international security threats inside and outside the NATO boundaries. With the NATO withdrawal scenario from Afghanistan starting to unfold, NRF seems to be the tool for the future.

Generally, SOF has played major role in NATO for the past decade and still does. With NRF being NATO's future tool, SOF will continue to justify their legacy. The unconventional threats will continue to lurk and shape the future. Nonetheless, SOF will always be the main thrust to face them.

Austerities that struck NATO, especially after the financial crisis, will probably continue to render more difficulties for the Alliance in the next decade. Nonetheless, NRF and the Smart Defense concept will be beneficial to overcome these difficulties. With the Smart Defense concept, countries will be able to focus on developing only particular capabilities, niche capabilities, which will be more cost effective and practical. Once they develop those capabilities, they can pledge to NRF and fulfil their contribution to NATO. As the earlier analysis showed the benefits of developing SOF niche capability, developing SOF capability is more than beneficial for the small countries. First, developing SOF capabilities is cost efficient, and easier to develop and maintain. On the other hand, when compared to the rest of the conventional forces that are more expensive and harder to maintain, with a smaller force, SOF can achieve higher results on the strategic and operational levels.

For the smaller countries, apart from developing SOF capability, how they can be employed respectively as part of NRF is very important. This research proposed two concepts on how small countries' SOF can contribute to NATO SOF as part of the NRF.

The first concept is more or less similar to the previous employments of the smaller countries' SOF, both from NATO and partner countries with other larger NATO countries. In the past engagement in Iraq and Afghanistan, this cooperation has been more prevalent with the United States. However, the proposed model suggested establishing a combined SOTG of a larger and more mature NATO SOF country and smaller countries, either NATO or partner countries. In this model, small countries will contribute a SOLTU element. According to Allied Joint Publication 3.5, the combined SOTG anticipates having one commander,¹³³ the leading nation/commander who will be designated from the larger country. This concept proposed that contributing forces be mostly from the European countries in order to build capable SOF that do not have to heavily rely on the United States, as has been the case in the past decade. This determination will also help NATO to ease the reliance on the United States and establish a larger cooperation between European countries.

The second concept proposed in this research envisioned creation of a combined SOTG from multiple smaller countries that will provide SOLTU elements. This concept appears to be more challenging in regard to the diversity of SOF from multiple countries. DOTMLPFI addressed some of the challenges and how they can be overcome, but the key to the success is their mutual cooperation and training in the long term. SOF is a very useful tool that can accomplish more than the conventional forces, but developing them to a complete readiness stage requires an extended period of time. Having all these different SOF working effectively together will require even more time. Consequently,

¹³³NATO, AJP 3.5, 3-4.

mutual development of these capabilities should be imperative for the countries that will decide to work and create a combined SOTG.

Based on the niche capabilities concept, in regard to both concepts, a gap analysis will determine if there are particular capabilities that are missing or that should be further developed. Once a capability shortfall is defined, some of the countries that are more capable of developing them can develop them as a niche capability. Yet, in developing niche capabilities, small countries should be aware of balancing the capabilities/troop contribution to NATO/NRF and their internal security. As one of the key tasks for any SOF primarily is to provide internal security and face the internal threats, providing SOF niche capability to NATO might degrade their full engagement inside their respective country.

The proposed SOTG models, once they have reached their readiness status, can be attached to NRF and be used to conduct operations in support of the NRF's mission. They have to be able to conduct the NATO SOF core tasks: Direct Actions, Military Assistance and Special Reconnaissance, and be able to support the NATO core tasks: Collective Defense, Crisis Response and Cooperative Security.

The findings of this research indicate that the proposed models of small countries' SOF employment are feasible. This means that the B-9 concept or the Baltic States Special Operations Forces can serve as a bedrock for further development of this kind of concept among small countries in order to improve their capabilities, to be able to contribute to NRF and NATO independently, or in conjunction with bigger countries.

One of the implications that derives from this research is the defense budget spending. In order to develop and maintain capable SOF ready to be pledged to NRF,

some of the small countries would have to increase their defense spending and invest in the further national SOF development. Another implication arising from the research, concerning the second model of employment, is the enhancement of the cooperation and developing all the capabilities needed for a combined SOTG only from small countries. This would include the special operations air task unit and special operations maritime task unit.

After 2014, NATO will shift its emphasis from operational engagement to operational preparedness, which means that NATO will need to remain capable of performing its core tasks and maintaining its forces at a high level of readiness. Even though past decades NATO's focus has been generally in fighting threats outside NATO's borders, the last conflict in Ukraine was an alarm for NATO to reassess its plans and shift its focus more towards collective defense.

NRF as part of the NATO Force 2020 concept will remain the flagship for its implementation and the key tool for the Connected Force Initiative concept that embodies a modern, tightly connected, properly equipped, well-trained, and exercised force. SOF as part of the NRF's Immediate Response Force will be the strongest and most feasible tool to fulfill NRFs mission as a Response Force.

Recommendations

As austerities will continue to limit NATO and NRF, and as the United States slowly is reducing its commitment in NATO, proxy forces should be developed to fulfill the emerging gaps. Utilization of all available forces within NATO members and partners will be imperative for the future. In this regard, further analysis and research should be

done on how to best utilize smaller countries' SOF in order to produce more robust NATO SOF capabilities.

This research analyzed and proposed two models on how small countries' SOF can contribute to NRF. However, this research did not cover all small countries and their capabilities. That was not within the scope of this research. Due to a lack of appropriate materials on these countries' SOF because of their classification, this research did not cover all the details of these small countries' SOF capabilities. As the security environment changes, further research should be done in this area and how these countries can increase their contribution in the future. This thesis can serve as a bedrock for further research on this topic.

BIBLIOGRAPHY

Briefings, Studies, Research Papers

- Aronsson, Dr. Lisa, and Dr. Molly O'Donnell. "Smart Defense and the Future of NATO: Can the Alliance Meet the Challenges of the Twenty-First Century?" Conference Report and Expert Papers, The Chicago Council on Global Affairs, Chicago, IL, 28-30 March 2012.
- Belkin, Paul, Derek E. Mix, and Steven Woehrel. Congressional Research Service Report 43478, *NATO: Response to the Crisis in Ukraine and Security Concerns in Central and Eastern Europe*. Washington, DC: Library of Congress, 16 April 2014.
- Goodpaster, Andrew J., and Arthur K. Cebrowski. *NATO Transformation: Problems and Prospects, a Compendium*. Washington, DC: The Atlantic Council of the United States, 2004.
- Iffert, Rolland G., LtCol. "NATO Response Force Briefing to 'NATO Staff Officer Orientation Course,' M5-32-C-12." Oberammergau, Germany, 8 May 2012.
- Larrabee, F. Stephen, Stuart E. Johnson, John Gordon IV, Peter A. Wilson, Caroline Baxter, Deborah Lai, and Calin Trenkov-Wermuth. *NATO and the Challenges of Austerity*. Santa Monica, CA: RAND Corporation, 2012.
- Lasconjarias, Guillaume. No.88, "The NRF: From a Key Driver of Transformation to a Laboratory of the Connected Forces Initiative." Research Division, North Atlantic Treaty Defense College, Rome, Italy, January 2013.
- Moroney, Jennifer D. P., Adam Grissom and Jefferson P. Marquis. *A Capabilities-Based Strategy for Army Security Cooperation*. Santa Monica, CA: Rand Arroyo Center. 2007.

Government Documents

- Joint Chiefs of Staff. Joint Publication 1-02, *Department of Defense Dictionary of Military and Associated Terms*. Washington, DC: US Government Printing Office, 8 November 2010 (As Amended Through 15 March 2014).
- NATO Special Operations Coordination Center. *SOTG MANUAL* Version 1.0. Mons, Belgium: North Atlantic Treaty Organization, 11 December 2009.
- NATO Special Operations Headquarters. *Special Operations Forces Study*. Mons, Belgium: North Atlantic Treaty Organization, December 2012.

North Atlantic Treaty Organization. Allied Joint Publication 3 (B), *Allied Joint Doctrine for the Conduct of Operations*. Brussels, Belgium: Military Agency for Standardization, 2011.

_____. Allied Joint Publication 3.5 *Allied Joint Doctrine for Special Operations*, Edition A, Version 1. Brussels, Belgium: NATO Standardization Agency, December 2013.

_____. *NATO Handbook*. Brussels-Belgium: North Atlantic Treaty Organization Office of Information and Press, 2001.

Journals/Periodicals

Attrill, Mark, Wg Cdr, GBR AF. "A JWC Support to the NATO Response Force." *The Three Swords Magazine*, no. 25 (July/October 2013): 40-42.

Barry, Charles. "Building Future Transatlantic Interoperability Around a Robust NATO Response Force." *Institute for National Strategic Studies Transatlantic Current* no. 7 (October 2013): 4-5.

Binnendijk, Hans, David C. Gompert, and Richard L. Kugler. "A New Military Framework for NATO." *Defense Horizons*, no. 48 (May 2005): 17.

Bonsignore, Luca. "NRF Key Element of NATO Transformation The Nato Response Force (NRF). *NATO's Nations and Partners for Peace* 50, no. 2 (2005): 44-49.

Gompert, David C., and Raymond C. Smith. "Creating a NATO Special Operation Forces." *Defense Horizons*, no. 52 (March 2006): 2-3.

Johnson, Paul, Tim LaBenz, and Darrell Driver. "Smart Defense Brave New Approach or Déjà Vu?" *Naval War College Review* 66, no. 3 (Summer 2013): 45-46.

Ruehle, Michael. "NATO after Prague: Learning the Lessons of 9/11." *Parameters* 33, no. 2 (Summer 2003): 89.

Online Sources

Afghanistan International Security Assistance Force. "Delivering CTF 77 to the Fight." North Atlantic Treaty Organization. <http://www.isaf.nato.int/article/news/delivering-ctf-77-to-the-fight.html> (accessed 20 April 2014).

Allied Command Operations. "The NATO Response Force." North Atlantic Treaty Organization. <http://www.aco.nato.int/page349011837.aspx> (accessed 2 February 2014).

- Balkan Security Agenda. "International Special Forces Exercise 'Eagle 2013' Completed." <http://www.balsec.org/policy-areas/defence-and-security/international-special-forces-exercise-eagle-2013-completed/> (accessed 12 April 2014).
- Calha, Julio Miranda. *147 DSCTC 03 E - Reform of NATO Command Structure and the NATO Response Force*, November 2003. NATO Parliamentary Assembly. <http://www.nato-pa.int/default.asp?SHORTCUT=365> (accessed 17 March 2014).
- Coalson, Robert. "What Are NATO's Articles 4 And 5?" Radio Free Europe Radio Liberty. 26 June 2012. <http://www.rferl.org/content/explainer-nato-articles-4-and-5/24626653.html> (accessed 5 March 2014).
- Dellinger, Buck, LtCol. "Strengthening Partnerships for Global Security." *Special Warfare* (April-June 2012). <http://www.soc.mil/swcs/SWmag/archive/SW2502/SW2502SpecialOperationsCommandEurope.html> (accessed 15 April 2014).
- Estonian Defense Forces. "Special Operations," 11 March 2014. <http://www.mil.ee/en/defence-forces/special-operations> (accessed 26 April 2014).
- Ford, Matt. "Russia's Seizure of Crimea is Making Former Soviet States Nervous." *The Atlantic*. 1 March 2014. <http://www.theatlantic.com/international/archive/2014/03/russias-seizure-of-crimea-is-making-former-soviet-states-nervous/284156/> (accessed 1 May 2014).
- Garamone, Jim. "Officials announce first Afghanistan surge units," 8 December 2009. The Official Homepage of the United States Army. http://www.army.mil/article/31457/Officials_announce_first_Afghanistan_surge_units/ (accessed 25 February 2014).
- Garnett, Ian. "NATO Response Force." *RUSI Journal* 148, no. 6 (December 2003): 20-25. <http://search.proquest.com/docview/212112747?accountid=28992> (accessed 14 January 2014).
- Hungarian Government. "HDF Special Operations Team." Hungarian Government Website. <http://www.kormany.hu/en/hungary-in-afghanistan/about-our-teams-and-contingents/hdf-special-operations-team> (accessed 1 April 2014).
- International Institute for Strategic Studies. *The Military Balance 2014*. <http://www.iiss.org/en/publications/military-s-balance> (accessed 20 April 2014).
- Joint Warfare Center. "Training." North Atlantic Treaty Organization. <http://www.jwc.nato.int/activities/training> (accessed 20 April 2014).
- Merriam-Webster, "Niche." <http://www.merriam-webster.com/> (accessed 16 April 2014).

- Miles, Donna. "Jackal Stone Promotes Special Operations Partnershi." U.S. Department of Defense. 18 September 2012. <http://www.defense.gov/news/newsarticle.aspx?id=117917> (accessed 20 March 2014).
- Ministry of Defense Republic of Macedonia. *White Paper on Defense*, September 2012. <http://www.morm.gov.mk/wp-content/uploads/2013/12/WHITE-PAPER-OF-DEFENCE.pdf> Published September 2012 (accessed 20 April 2014).
- Ministry of National Defence Republic of Lithuania. "Baltic Defense Ministers Announced New Defense Cooperation Initiatives." Republic of Lithuania. http://www.kam.lt/en/news_1098/current_issues/baltic_defence_ministers_announced_new_defence_cooperation_initiatives.html (accessed 10 April 2014).
- Ministry of National Defence Republic of Macedonia. "SOR Participation in Exercise B-9 in Republic of Serbia," 30 October 2013. http://www.arm.mil.mk/vesti/pocetna/2013/10/en_vezba_pso.html (accessed 12 March 2014).
- Morelli, Vincent, Carl Ek, Paul Belkin, Steve Woerhel, and Jim Nichol. Congressional Research Service Report RL 34701, *NATO Enlargement: Albania, Croatia, and Possible Future Candidates*, 14 April 2009. Federation of American Scientists. <http://www.fas.org/sgp/crs/row/RL34701.pdf> (accessed 28 April 2014).
- NATO Parliamentary Assembly. *160 DSCTC 08 E REV 1 - Current And Future Capability Priorities for the Atlantic Alliance*, 5 November 2007. North Atlantic Treaty Organization. <http://www.nato-pa.int/Default.asp?SHORTCUT=1474> (accessed 11 November 2013).
- NATO Rapid Deployable Corps (Italy). "NATO Response Forces 3." 22 October 2013. North Atlantic Treaty Organization. <http://www.nato.int/nrdc-it/index.htm> (accessed 29 October 2013).
- NATO Special Operations Headquarters. "NATO SOF Professional Military Education." North Atlantic Treaty Organization. <https://www.nshq.nato.int/nsos/> (accessed 20 March 2014).
- North Atlantic Treaty Organization. "The Connected Force Initiative." 24 October 2013. http://www.nato.int/cps/en/natolive/topics_98527.htm (accessed 3 March 2014).
- _____. "Crisis Management." 27 October 2010. http://www.nato.int/cps/en/SID-DAFBA165-411F6D78/natolive/topics_49192.htm?blnSublanguage=true&selectedLocale=uk&submit=select (accessed 15 March 2014).
- _____. "The NATO Response Force." 22 February 2013. http://www.nato.int/cps/en/natolive/topics_49755.htm (accessed 10 September 2013).
- _____. *The North Atlantic Treaty*. 9 December 2008. http://www.nato.int/cps/en/natolive/official_texts_17120.htm (accessed 3 March 2014).

- _____. “Prague Summit Declaration.” 21 November 2002, updated 18 January 2008. <http://www.nato.int/docu/pr/2002/p02-127e.htm> (accessed 19 February 2014).
- Solana, Javier. “The Washington Summit: “NATO steps boldly into the 21st century.” North Atlantic Treaty Organization. <http://www.nato.int/docu/review/1999/9901-01.htm> (accessed 12 January 2014).
- Terriff, Terry, Frans Osinga, and Theo Farrell. *A Transforming Gap?* Redwood City, CA: Stanford University Press, 2010.
- United States Army Combined Arms Center. “Joint Combined Exchange Training.” 17 September 2008. <http://usacac.army.mil/cac2/call/thesaurus/toc.asp?id=34288> (accessed 15 April 2014).
- United States European Command. “Exercise Jackal Stone.” <http://www.eucom.mil/key-activities/exercises-and-operations/exercise-jackal-stone> (accessed 25 April 2014).
- _____. “Lithuania Takes Lead at Combined Endeavor.” 19 September 2011. <http://www.eucom.mil/article/22592/lithuania-takes-lead-at-combined-endeavor> (accessed 4 April 2014).