

# RANCHERO EXPLOSIVE PULSED POWER EXPERIMENTS

J. H. Goforth, W. A. Anderson, E. V. Armijo, W. L. Atchison, J. J. Bartos, D. A. Clark, R. D. Day, W. J. Deninger, R. J. Faehl, C. M. Fowler, F. P. Garcia, O. F. Garcia, D. H. Herrera, T. J. Herrera, R. K. Keinigs, J. C. King, I. R. Lindemuth, E. A. Lopez, E. C. Martinez, D. Martinez, J. A. McGuire, D. Morgan, H. Oona, D. M. Oro, J. V. Parker, R. B. Randolph, R. E. Reinovsky, G. Rodriguez, J. L. Stokes, F. C. Sena, L. J. Tabaka, D. G. Tasker, A.J. Taylor, and D. T. Torres,  
Los Alamos National Laboratory,  
H. D. Anderson, W. B. Broste, and J. B. Johnson, Bechtel Nevada.

## Abstract

We are developing the Ranchero high explosive pulsed power (HEPP) system to power cylindrically imploding solid-density liners for hydrodynamics experiments. Our near-term goal is to conduct experiments in the regime pertinent to the Atlas capacitor bank.<sup>1</sup> That is, we will attempt to implode liners of ~50 g mass at velocities approaching 15 km/sec. The basic building block of the HEPP system is a coaxial generator with a 304.8 mm diameter stator, and an initial armature diameter of 152 mm. The armature is expanded by a high explosive (HE) charge detonated simultaneously along its axis. We have reported a variety of experiments conducted with generator modules 43 cm long<sup>2,3</sup> and have presented an initial design for hydrodynamic liner experiments.<sup>4</sup> In this paper we give a synopsis of our first system test, and a status report on the development of a generator module that is 1.4 m long.

## I. IMPLOSION SYSTEM TEST

Our first system test had the goal of approaching 10 km/sec implosion velocity for an aluminum liner of 40g. In addition, this test demonstrated our power flow design concept, which includes some techniques planned for the Atlas capacitor bank. Figure 1 shows the apparatus in transit to the HE firing point. Mounted on a trailer for transportation are the generator, fuse opening switch (FOS), closing switch plates, conical power flow section, and the outer conductor of the implosion section. Extending outside of the picture are racks for mounting three 450 kV x-ray heads and accompanying explosive-proof film cassettes. The generator is a 43 cm long Ranchero module, and the FOS is 50 $\mu$ m thick copper, 30 cm long and 2.86 m wide. The closing switch plates have 12 detonator-actuated switches arranged symmetrically to puncture a 1.25 mm polyethylene sheet that can be seen protruding from the plates. The performance of these HEPP components has been previously described.<sup>4</sup> Fig. 2 is an illustration of the system showing the pulsed power

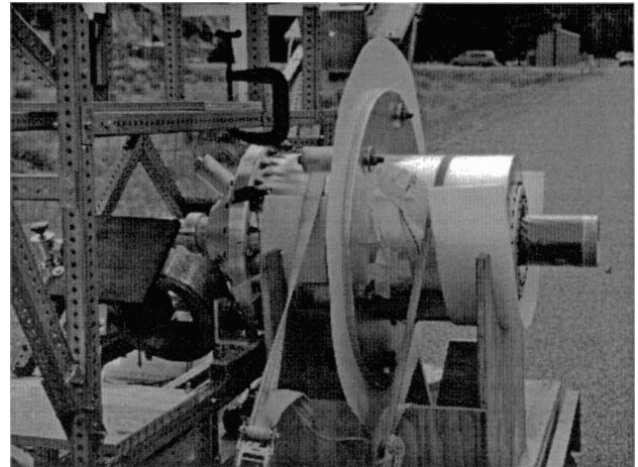

Figure 1. Photograph of first successful Ranchero liner test. The 43 cm generator is the cylindrical component in right of picture, with its smaller diameter armature protruding furthest to the right. Polyethylene insulation protrudes from closing switch plates in the middle, and the next component to the left is the FOS section. The conical transmission line leads to the small diameter implosion section. The racks support three 450 kV x-ray heads (out of the picture) and their associated HE-proof film cassettes.

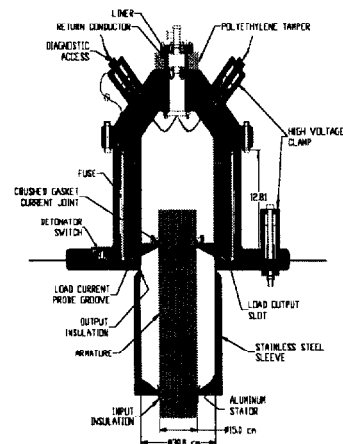

Figure 2. Cutaway drawing of system in Fig. 1.

## Report Documentation Page

*Form Approved*  
*OMB No. 0704-0188*

Public reporting burden for the collection of information is estimated to average 1 hour per response, including the time for reviewing instructions, searching existing data sources, gathering and maintaining the data needed, and completing and reviewing the collection of information. Send comments regarding this burden estimate or any other aspect of this collection of information, including suggestions for reducing this burden, to Washington Headquarters Services, Directorate for Information Operations and Reports, 1215 Jefferson Davis Highway, Suite 1204, Arlington VA 22202-4302. Respondents should be aware that notwithstanding any other provision of law, no person shall be subject to a penalty for failing to comply with a collection of information if it does not display a currently valid OMB control number.

1. REPORT DATE <b>JUN 1999</b>	2. REPORT TYPE <b>N/A</b>	3. DATES COVERED <b>-</b>	
4. TITLE AND SUBTITLE <b>Ranchero Explosive Pulsed Power Experiments</b>		5a. CONTRACT NUMBER	
		5b. GRANT NUMBER	
		5c. PROGRAM ELEMENT NUMBER	
6. AUTHOR(S)		5d. PROJECT NUMBER	
		5e. TASK NUMBER	
		5f. WORK UNIT NUMBER	
7. PERFORMING ORGANIZATION NAME(S) AND ADDRESS(ES) <b>Los Alamos National Laboratory</b>		8. PERFORMING ORGANIZATION REPORT NUMBER	
9. SPONSORING/MONITORING AGENCY NAME(S) AND ADDRESS(ES)		10. SPONSOR/MONITOR'S ACRONYM(S)	
		11. SPONSOR/MONITOR'S REPORT NUMBER(S)	
12. DISTRIBUTION/AVAILABILITY STATEMENT <b>Approved for public release, distribution unlimited</b>			
13. SUPPLEMENTARY NOTES <b>See also ADM002371. 2013 IEEE Pulsed Power Conference, Digest of Technical Papers 1976-2013, and Abstracts of the 2013 IEEE International Conference on Plasma Science. Held in San Francisco, CA on 16-21 June 2013. U.S. Government or Federal Purpose Rights License.</b>			
14. ABSTRACT <b>We are developing the Rancher0 high explosive pulsed power (HEPP) system to power cylindrically imploding solid-density liners for hydrodynamics experiments. Our near-term goal is to conduct experiments in the regime pertinent to the Atlas capacitor bank. That is, we will attempt to implode liners of -50 g mass at velocities approaching 15 km/set. The basic building block of the HEPP system is a coaxial generator with a 304.8 mm diameter stator, and an initial armature diameter of 152 mm. The armature is expanded by a high explosive (HE) charge detonated simultaneously along its axis. We have reported a variety of experiments conducted with generator modules 43 cm long<sup>2</sup> and have presented an initial design for hydrodynamic liner experiments.<sup>4</sup> In this paper we give a synopsis of our first system test, and a status report on the development of a generator module that is 1.4 m long.</b>			
15. SUBJECT TERMS			
16. SECURITY CLASSIFICATION OF:			17. LIMITATION OF ABSTRACT
a. REPORT <b>unclassified</b>	b. ABSTRACT <b>unclassified</b>	c. THIS PAGE <b>unclassified</b>	<b>SAR</b>
			18. NUMBER OF PAGES <b>3</b>
			19a. NAME OF RESPONSIBLE PERSON

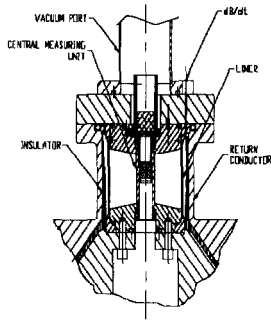

Figure 3. Load region for Ranchero liner test. The central measuring unit houses VISAR and fiber optic diagnostic assemblies.

components described above, as well as power flow and diagnostics features. Fig. 3 is a blow-up of the load region. Mounted inside the liner are optical pin and VISAR diagnostics.  $dB/dt$  probes near the liner give information about current symmetry and the voltage integrity of the insulator, which is immediately adjacent to the liner in this design. Fig. 4 shows the pulsed power results from the test. An initial current of 4 MA was delivered to Ranchero, and a peak current of 25.6 MA was generated. 15 MA was delivered to the load. It is possible that the generator volume shorted out with  $\sim 3$  mm remaining in the armature/stator gap. This is a small amount of inductance, but represents a substantial fraction of the storage inductance on this test. We are still analyzing these data, and it is important to understand this issue for future experiments. Due to a priming circuit cable fault, the initial current was 0.5 MA less than originally planned, which resulted in delayed fuse actuation, and hence to a reduced liner current. Although we planned for 20 MA liner current, the achieved values

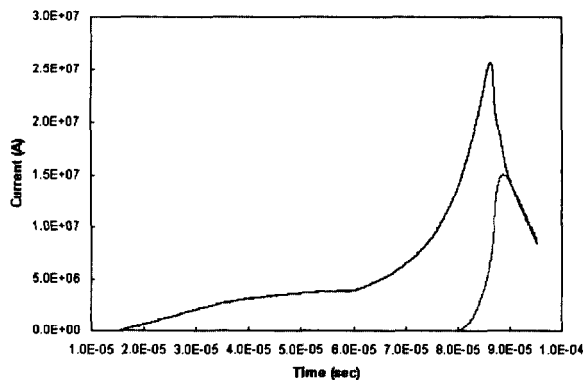

Figure 4. Generator and load currents from liner test.

provide us with a good first look at our system, and all diagnostics returned results. The liner reached a velocity of 6.3 km/sec, as measured by the VISAR. In addition, x-rays taken at three separate times show the liner behaving very well, and at locations consistent with computational

results based on the actual waveform. Samples of these x-rays are presented in another paper in this conference.<sup>5</sup> The  $dB/dt$  probes indicated no restrike along the insulator surface near the liner, and good current symmetry within the errors of the measurement.

## II. 1.4 m SYSTEM TESTS

The HE system necessary for 1.4 m Ranchero modules has required more development than we anticipated, but has recently been demonstrated to perform satisfactorily. Fig. 5 is a rotating mirror camera record showing the expansion of a 6mm-thick aluminum armature to the desired diameter. Only two-thirds of the armature is seen in the figure, as good optical resolution dictated that we cover only part of the armature with a single camera. Another camera shows equally good results from the remaining part of the system. The system is detonated at 56 discrete locations along the axis with a 112-point slapper detonator system (two points back-to-back at each site). To reduce costs, we use a room temperature castable explosive for the main charge, which is cast around the slapper/booster-pellet system. Difficulties in development included detonating the large number of points reliably, casting such large charges without disturbing the slapper system, and failure to promptly initiate the PBXN-110 cast charge with the low-density PETN detonator explosive. The latter difficulty is solved

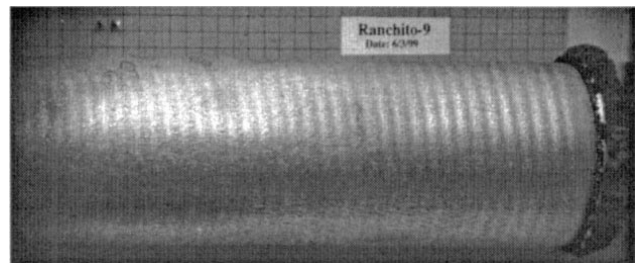

Figure 5. Rotating mirror camera record of 1.4 m armature expanded to the approximate final diameter for use in a Ranchero generator. Only about 2/3 of the armature is shown in this frame. The remainder of the armature was seen with a second camera. The grid pattern is 25.4 mm per line.

by adding an intermediate booster explosive<sup>6</sup>. We have recently tested our first 1.4 m Ranchero module. The results are shown in fig. 6. The module had parallel stator and armature walls, and used a 4 mm-thick polyethylene insulator along the stator, in the same manner as early 43 cm Ranchero module tests<sup>2</sup>. In addition, as with 43 cm module tests, the generator volume is filled with atmospheric pressure  $SF_6$ . The test had a static load of 5 nH, in addition to the inductance of  $\sim 5$ nH left in the generator due to the thick (4mm) insulator. Pre-shot calculations based on residual inductance information previously published indicated that a peak current of  $32 \pm 6$  MA would be achieved given an initial current of 2.2

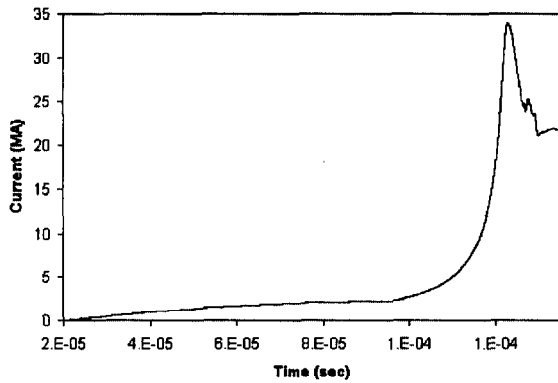

Fig. 6. Current from 1.4 m Ranchero test.

MA. Our most optimistic model predicted 38 MA. The observed current indicates that residual inductance inferred from tests with thin stator insulators represents a loss that is not completely incurred if a thick insulator is used.

### III. CONCLUSIONS

We have demonstrated that the Ranchero system can be used to drive hydrodynamic liner experiments with an excellent compliment of diagnostics. Further experiments with 43 cm Ranchero modules could be conducted with liner drive currents of 20 MA or slightly more, but the availability of the 1.4 m module allows us to proceed to the 30 MA level, which is consistent with current programmatic goals for the Atlas capacitor bank. The 1.4 m module can be attached to the existing power flow design with no modifications, and diagnostics will not be appreciably affected by the increased HE charge. Fuse dimensions will change to reflect increased performance of the system. Early experiments will investigate the stability of liners driven with this current and time scale. Calculations show that at least part of the liner should remain solid during the implosion to maintain stability. For increased performance from the Ranchero system, we propose to first reduce the stator insulation to its minimum practical value. This reduces the residual inductance in the generator, and allows substantially higher current to be achieved. Alternatively, it allows the same current with more inductance outside the generator volume so that the generator can be

crowbarred out of the circuit, if this proves to be desirable. We are exploring the potential advantages of crowbarring the generator from the circuit when flux compression is complete. Several other options remain, such as evacuating the module rather than filling it with SF<sub>6</sub>. We will pursue these possibilities as time and programmatic needs allow.

### REFERENCES

- [1] R.K. Keinigs, et al., "One-and Two-Dimensional Simulations of Liner Performance at Atlas Parameters," J. Appl. Phys. (to be published).
- [2] J. H. Goforth, et al., "Ranchero: A High Current Flux Compression Generator System for Heavy Liner Experiments," Seventh International Conference on Megagauss Magnetic Field Generation and Related Topics, (Cherneyshev, Selemir, Plyashkevich eds.) RFNC-VNIIEF, 1997, pp 254-259.
- [3] J. H. Goforth, et al., "The Ranchero Explosive Pulsed Power System," Eleventh IEEE International Pulsed Power Conference, (Cooperstein and Vitkovitsky eds.), IEEE, Inc. 1997. pp. 573-578.
- [4] J. H. Goforth, et al., "Hydrodynamic Liner Experiments Using The Ranchero Flux Compression Generator System," Eighth Conference on the Generation of Megagauss Magnetic Fields, Tallahassee, 1998, to be published.
- [5] H. Oona, "Liner Compression and Instabilities and Shocks at High Currents with the Pegasus and Ranchero Sources," this conference.
- [6] D. G. Tasker, et al., "Optimizing the Rancho Coaxial Flux Compression Generator," Eighth Conference on the Generation of Megagauss Magnetic Fields, Tallahassee, 1998, to be published.

### IV. ACKNOWLEDGEMENT

We would like to acknowledge the contribution of Don Breithaupt and the rest of our Lawrence Livermore National Laboratory and Bechtel Nevada colleagues who provided us with the camera record in figure 5, and a great deal of other camera support, from their BEEF facility in Nevada.