

FRC COMPRESSION HEATING EXPERIMENT (FRCHX) AT AFRL*

Chris Grabowski^ξ, James Degnan, Mark Babineau, Frank Camacho, Sean Coffey, Gordon Coulter, Matt Domonkos, Don Gale, Bernard Martinez, Jerry Parker, Dale Ralph, Ed Ruden, and Wayne Sommars

*Air Force Research Laboratory, Directed Energy Directorate, 3550 Aberdeen Avenue SE
Kirtland AFB, NM 87117-5776 USA*

Scott Hsu, Tom Intrator, Richard Renneke, Paul Sieck, Bill Waganaar, and Glen Wurden

*Los Alamos National Laboratory
Los Alamos, NM 87545 USA*

Abstract

Over the past seven years, the Air Force Research Laboratory in Albuquerque, NM has been working in close collaboration with Los Alamos National Laboratory on their field-reversed configuration (FRC) experiment, FRX-L. Through these joint efforts a second experiment has been designed and is now being assembled and tested at the AFRL. This new experiment, which is referred to as the FRC Heating Experiment (FRCHX), has the goal of not only forming a plasma in a field-reversed configuration but of also translating it into an aluminum flux conserving shell (solid liner), where it will be subsequently heated through rapid compression of the liner. The FRC formation portion of FRCHX has been designed to closely match the electrical properties of FRX-L so that FRCs of similar parameters can be formed. Likewise, the translation portion of FRCHX, which has been designed and fabricated concurrently with the new translation section of FRX-L, also closely matches that of FRX-L. The design approach being taken to compressively heat the FRC in the final portion of FRCHX relies on the experimental setup used during two earlier “deformable-contact” vacuum liner experiments that were performed with the Shiva Star Capacitor Bank. In these experiments the liner electrodes had 8-cm-diameter holes on their axes, and both tests were found to be successful in that the ends of the 10-cm diameter, 30-cm long aluminum liner stretched and maintained contact with the electrodes while the body of the liner glided radially inward to implode uniformly.

This presentation focuses on the system design and integration of the first two portions of the FRCHX experiment, the FRC formation and translation sections. The measured and/or intended performance of each are discussed, along with the various magnetic and plasma diagnostics that are being fielded in both sections. The remaining tasks to be accomplished before a complete FRC formation, translation, and compression experiment can be performed are also outlined at the end.

I. INTRODUCTION

The concept of the Field Reversed Configuration (FRC) has been in existence for more than forty years, but FRCs continue to be of considerable scientific interest due to their many inherent features that make them attractive for use in a fusion reactor scheme. They have a simple geometry with high β and a high power density, implying that a relatively efficient and compact reactor could be developed. Their magnetic field configuration includes a natural divertor, which will assist in reducing the amount of impurities entering from the vacuum vessel walls. They also have a demonstrated translatability, allowing the formation region and the region where subsequent heating occurs to be isolated from each other [1].

The Air Force Research Laboratory (AFRL) and Los Alamos National Laboratory (LANL) have been working together closely for several years on the development of an FRC experiment that has the goal of compressively heating an FRC plasma to fusion-relevant densities and temperatures and doing so in a manner that could potentially be employed in a fusion reactor. The groundwork for this effort has been both the FRX-L (Field Reversed eXperiment – Liner) experiment at LANL, which has focused on the formation of FRC’s with parameters suitable for subsequent adiabatic liner compression [2-4], and a pair of vacuum liner implosion experiments that were performed at the AFRL’s Shiva Star facility, which were performed to study the axial and radial uniformity of imploding liners gliding radially inward over open apertures in their electrodes [5]. The new AFRL and LANL experiment, into which the experience and key design concepts from these two earlier efforts are integrated, is being referred to as the Field-Reversed Configuration Heating Experiment (FRCHX), and it will serve as the first laboratory Magnetized Target Fusion (MTF) demonstration experiment. The pulsed power banks, vacuum hardware, control system, and other experimental components are being assembled at AFRL in close proximity to the Shiva Star bank, where the

* Work supported by the US Dept of Energy Office of Fusion Energy Studies under contract number FA9451-05-D-0004

^ξ email: theodore.grabowski@kirtland.af.mil

Report Documentation Page

Form Approved
OMB No. 0704-0188

Public reporting burden for the collection of information is estimated to average 1 hour per response, including the time for reviewing instructions, searching existing data sources, gathering and maintaining the data needed, and completing and reviewing the collection of information. Send comments regarding this burden estimate or any other aspect of this collection of information, including suggestions for reducing this burden, to Washington Headquarters Services, Directorate for Information Operations and Reports, 1215 Jefferson Davis Highway, Suite 1204, Arlington VA 22202-4302. Respondents should be aware that notwithstanding any other provision of law, no person shall be subject to a penalty for failing to comply with a collection of information if it does not display a currently valid OMB control number.

1. REPORT DATE

JUN 2007

2. REPORT TYPE

N/A

3. DATES COVERED

-

4. TITLE AND SUBTITLE

FRC Compression Heating Experiment (FRCHX) AT AFRL

5a. CONTRACT NUMBER

5b. GRANT NUMBER

5c. PROGRAM ELEMENT NUMBER

6. AUTHOR(S)

5d. PROJECT NUMBER

5e. TASK NUMBER

5f. WORK UNIT NUMBER

7. PERFORMING ORGANIZATION NAME(S) AND ADDRESS(ES)

**Air Force Research Laboratory, Directed Energy Directorate, 3550
Aberdeen Avenue SE Kirtland AFB, NM 87117-5776 USA**

8. PERFORMING ORGANIZATION
REPORT NUMBER

9. SPONSORING/MONITORING AGENCY NAME(S) AND ADDRESS(ES)

10. SPONSOR/MONITOR'S ACRONYM(S)

11. SPONSOR/MONITOR'S REPORT
NUMBER(S)

12. DISTRIBUTION/AVAILABILITY STATEMENT

Approved for public release, distribution unlimited

13. SUPPLEMENTARY NOTES

See also ADM002371. 2013 IEEE Pulsed Power Conference, Digest of Technical Papers 1976-2013, and Abstracts of the 2013 IEEE International Conference on Plasma Science. IEEE International Pulsed Power Conference (19th). Held in San Francisco, CA on 16-21 June 2013., The original document contains color images.

14. ABSTRACT

Over the past seven years, the Air Force Research Laboratory in Albuquerque, NM has been working in close collaboration with Los Alamos National Laboratory on their field-reversed configuration (FRC) experiment, FRX-L. Through these joint efforts a second experiment has been designed and is now being assembled and tested at the AFRL. This new experiment, which is referred to as the FRC Heating Experiment (FRCHX), has the goal of not only forming a plasma in a field-reversed configuration but of also translating it into an aluminum flux conserving shell (solid liner), where it will be subsequently heated through rapid compression of the liner. The FRC formation portion of FRCHX has been designed to closely match the electrical properties of FRX-L so that FRCs of similar parameters can be formed. Likewise, the translation portion of FRCHX, which has been designed and fabricated concurrently with the new translation section of FRX-L, also closely matches that of FRX-L. The design approach being taken to compressively heat the FRC in the final portion of FRCHX relies on the experimental setup used during two earlier deformable-contact vacuum liner experiments that were performed with the Shiva Star Capacitor Bank. In these experiments the liner electrodes had 8-cmdiameter holes on their axes, and both tests were found to be successful in that the ends of the 10-cm diameter, 30-cm long aluminum liner stretched and maintained contact with the electrodes while the body of the liner glided radially inward to implode uniformly

15. SUBJECT TERMS

16. SECURITY CLASSIFICATION OF:			17. LIMITATION OF ABSTRACT SAR	18. NUMBER OF PAGES 4	19a. NAME OF RESPONSIBLE PERSON
a. REPORT unclassified	b. ABSTRACT unclassified	c. THIS PAGE unclassified			

Standard Form 298 (Rev. 8-98)
Prescribed by ANSI Std Z39-18

integrated demonstration experiments will be performed.

This paper outlines the designs of the FRC formation portion of the integrated experiment, as well as the systems needed to translate the FRC into the liner. Section II first discusses the FRC formation process and the pulsed power systems that will be used for forming the FRC. The various magnetic and plasma diagnostics fielded in the formation region are also described. Section III discusses the means for ejecting the FRC from the formation region, the additional fields that must be set up to guide the FRC into the solid liner, and the pulsed power systems that will be used to create these fields. The additional magnetic and plasma diagnostics needed to monitor the FRC during translation are also described in this section. Lastly, Section IV presents a brief status summary for the experiment and outlines the remaining tasks to be completed before performing the integrated compression heating experiment with the Shiva Star bank.

II. FRC FORMATION

A. Overview of the FRC Formation Process

FRC plasmas have a toroidal configuration with an embedded magnetic field that is predominantly, if not entirely, in the poloidal direction. An open field line region envelops the toroid, and it is this region that acts as a natural divertor for the FRC (as was mentioned above), hindering impurities from entering the plasma and allowing particles that are able to escape to do so axially rather than radially. This prevents the particles from depositing energy on the walls of the formation region.

Figure 1 illustrates how the FRC plasma and field structure is formed statically in both the FRX-L [2] and FRCHX experiments. First, a quasi-DC Bias field is set up in a theta pinch field coil. In the case of FRX-L, cusp fields at either end of the Theta coil are also applied at this time to create a more-pronounced radial field component here. Initially, FRCHX has used reduced-radius Theta coil segments at the ends ($r_i = 6.20$ cm versus $r_i = 6.70$ cm for the inner two segments) for this purpose, but recent numerical modeling has shown that the application of the cusp fields is a more efficient means of facilitating field line reconnection (described below). A low-pressure ($10 \sim 100$ mTorr) background of D_2 gas in the vacuum vessel is ionized next by applying a high-frequency ($230 \sim 250$

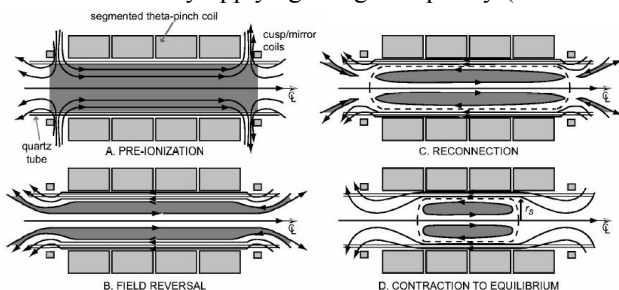

Figure 1. The FRC formation sequence: A. Bias and Cusp fields are applied; pre-fill gas is ionized. B. Main field is applied. C. Field lines reconnect. D. Plasma contracts until equilibrium is reached [2].

kHz) ringing Pre-Ionization (PI) field to the Theta coil. The Main field, which is oriented opposite to the Bias field, is then applied to compress the plasma that was just formed. As the plasma is compressed, outer field lines from the Main field that have penetrated the plasma tear and reconnect with the Bias field lines coming out from the core of the plasma at each end. The newly formed FRC continues to contract until reaching equilibrium.

Desired values for FRC plasma density and temperature after formation are $\sim 10^{17}$ cm^{-3} and 100-300 eV, respectively [4]. These values are targeted in our experiments by adjusting the pre-fill pressure in the vacuum vessel and by an appropriate choice of timings and amplitudes for the various magnetic fields. Densities and temperatures of this order are necessary, based upon computational results, to reach fusion-relevant conditions ($n \sim 10^{19}$ cm^{-3} , $T \sim$ several keV) after liner compression.

B. FRCHX Formation Banks

The FRCHX experiment uses three independent capacitor banks in the formation process: a Bias bank, consisting of two 2.5-mF bank modules that are switched with ignitrons, a PI bank, consisting of a single 2.1 μF capacitor switched with a rail-gap switch, and a Main bank, which is essentially a Shiva Star bank module ($C_{\text{upper}} = C_{\text{lower}} = 72$ μF) and is switched with a quad set of rail-gap switches. Though independently charged and triggered, these three banks all drive the same single-turn Theta coil; the diagram in Fig. 2 illustrates this arrangement. The ground and power supply connections to each bank are lifted prior to triggering, allowing a single-point experimental ground to be located at the Theta coil for the benefit of diagnostics. The Bias bank is isolated from the higher-voltage Main and PI banks by a high-impedance inductor (not shown).

Assembly of these banks has been completed, and several series of characterization tests have been performed. These tests have thus far been limited to somewhat modest currents, however, ~ 135 kA for the Bias

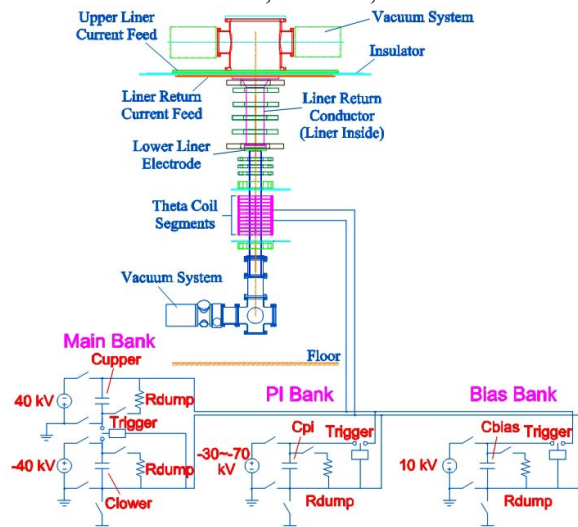

Figure 2. Sketch of the FRCHX field coils around the vacuum vessel and circuit diagram showing the layout of the formation pulsed power systems.

and PI banks and ~690 kA for the Main bank. We anticipate doubling these values in order to form FRCs appropriate for the compression heating experiments.

The Main bank current is crowbarred near its peak value with a second quad set of rail-gap switches for the purpose of extending the FRC lifetime. The Crowbar switch bus work was designed to keep inductance low and eliminate shared volume between the Theta coil and Main bank current loops passing through the switch. While the reduced self and mutual inductances have minimized the ripple on the Theta coil current waveform, because the voltage across the switch is already low when it is triggered, we often observe that once a few rail-gap switches begin to conduct the voltage collapses completely and the remaining rail gaps fail to conduct. Tests in which only the outer two rail gaps of the Crowbar were triggered (trigger cables on the inner two rail gaps were doubled up with the cables on the outer two rail gaps) have demonstrated that the inductive isolation between these two gaps is sufficient to allow reliable and reproducible operation of a Crowbar switch utilizing only these two switches.

To attempt to achieve reliable triggering for all four rail gaps, tests are presently being performed with an additional “Auxiliary” capacitor bank placed either in parallel with the Crowbar switch, to attempt to boost the voltage across the switch as it is triggered, or with the Crowbar’s triggering system, to attempt to extend the duration of the trigger pulse delivered to each rail gap and increase the likelihood of their closing. Thus far, the bank seems to provide some improvement, but performance is still typically such that not all rail gaps conduct.

C. Diagnostics in the FRCHX Formation Region

A variety of diagnostics is being set up in or around the Theta coil to characterize the plasma that is formed and the magnetic field topology surrounding the plasma. Diagnostics that are presently in place include magnetic pick-up loops, flux loops, fast imaging (visible light), and fiber optic light monitors. Signals from the pick-up and flux loops are used to estimate the maximum radius of the FRC’s closed field lines (i.e., the excluded flux radius). A fast imaging gated MCP camera with an exposure window of typically ~100 ns provides a record of visible plasma features (Fig. 3). A UV-sensitive camera and/or UV-

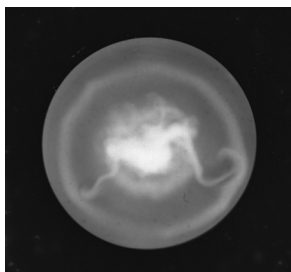

Figure 3. MCP camera image captured at the peak of the Main bank current. A wall plasma ring is seen circling a second FRC-like ring closer to the axis. A brighter end plasma is seen in the center of the image, which is likely axially closer to the camera than the two ring plasmas.

sensitive scintillators could be used to provide a view of the hotter regions of the plasma. Presently, a single fiber optic light monitor is in place to record the time the plasma first breaks down; eventually several such monitors will be placed along the formation region to follow the change in the FRC’s axial size during formation and its position as it leaves the Theta coil.

To measure the plasma density in the formation region a four-chord HeNe laser interferometer is being set up. The four interferometer beams will probe between the Theta coil segments at either a given axial location to map the FRC radial density profile or at different axial locations to map its axial density profile. The interferometer should be ready for use shortly after this conference.

III. FRC TRANSLATION

A. Requirements for Moving the FRC into the Liner

To facilitate FRC compression heating, the FRC must be ejected from the Theta coil rather quickly once it is formed and translated over the short distance (~80 cm) to the bore of the liner. Figure 4 (as well as Fig. 2 above) shows the relative position of the liner with respect to the Theta coil. To initiate the FRC motion, FRCHX’s four-segment cylindrical Theta coil will be replaced by an eleven-segment coil having a conical bore. The Main bank discharge will therefore not only form the FRC but also impart to it the kinetic energy needed to start its translation. The Theta coil’s conical bore is created by placing 2.54-cm-thick segments with gradually increasing inner radii adjacent to one another. A sufficient number of segments have been fabricated to allow cone angles from 0° to 6°, in increments of 0.2°, to be set up.

Along with the new conical Theta coil, the FRCHX experiment will also employ Cusp coils in the same manner as FRX-L. These coils will be single-turn coils, and will, in fact, consist of two of the Theta coil segments that will be driven independently. Additional coils to supply the guiding magnetic field along the translation region, a minor mirror at the entrance to the liner, and a stronger mirror field at the top of the liner to halt the

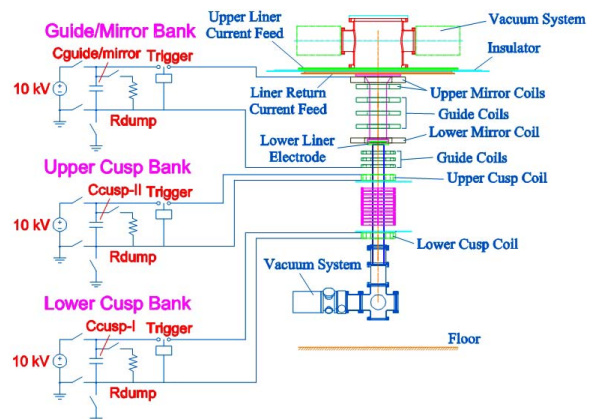

Figure 4. Sketch of the FRCHX field coils around the vacuum vessel and circuit diagram showing the layout of the translation pulsed power systems.

FRC's motion are also required. The minor mirror will be of sufficient amplitude to allow the FRC to pass through and enter the liner but will prevent it from leaving once it has reflected off the top mirror. Design work for the Guide and Mirror coils is nearly completed.

The conductivity of the liner, its electrodes, and the liner return conductor present some challenges with regard to setting up the Guide and Mirror fields inside the liner, as an appreciable time is required for these fields to diffuse through the metal structures and fill the liner bore. To determine how the Guide and Mirror field profiles are affected by diffusion processes, 2-D diffusion calculations have been performed (3-D are in progress) using COMSOL Multiphysics. Thinning the upper and lower liner electrodes in the analysis models and slotting the return conductor have greatly improved both the fill time of the liner and the axial field profile in the calculations.

B. FRCHX Translation Banks

The diagram in Fig. 4 indicates the bank circuits and the connections required for the Cusp, Guide, and Mirror coils. A single 12 mF capacitor bank, comprised of six 2-mF bank modules, has been fabricated to drive the ensemble of Guide and Mirror field coils. Two additional 1-mF banks have been fabricated to drive the two single-turn Cusp coils. The Cusp coils are being driven independently because it may be desirable to change the relative timing and/or amplitudes of their fields.

C. Diagnostics in the FRCHX Translation Region

The translation region will employ the same types of plasma and magnetic field diagnostics that are being used in the formation region. Magnetic pick-up loops and flux loops will again be used to determine the magnetic field profile, as well as the excluded flux radius and axial length of the FRC as it passes by the measurement location. Several fiber optic light monitors will also be placed along the translation region to make time-of-flight measurements. In addition, a second HeNe Laser interferometer with a single measurement chord is being assembled by University of New Mexico personnel to allow a measurement of the plasma density to be made just before the FRC enters the liner.

IV. PRESENT STATUS OF THE FRCHX EXPERIMENT

Vacuum and static pre-fill tests have been ongoing since January, primarily to characterize the operation of the three formation banks, as well as the Auxiliary bank intended to help with Crowbar switch closure. The tests thus far have typically been conducted at moderately low bank currents, as described earlier in Section IIB. The use of an Auxiliary bank improves the multiple rail gap operation of the Crowbar switch, but the number of rail gaps that conduct current still varies. The simpler technique of applying two triggers to each of the end rail gaps, however, which have more inductive isolation

between them reliably results in these two rail gaps participating in the Crowbar operation.

Along with examining the pulsed power systems, the tests have also served to characterize the formation region plasma diagnostics, in particular evaluating where noise problems lie and the accuracy of calibrations. As was described in Section IIC, good visible-light MCP camera images of the plasmas before and after the triggering of the Main bank have been obtained, though more interesting information can likely be gathered from UV images. Signals from the magnetic diagnostics are qualitatively good and have low noise, but analysis of the data to determine the excluded flux radius (if any) is still in progress. We anticipate needing to operate the experiment at higher currents and with cusp fields before we begin seeing strong evidence of the formation of FRCs appropriate for the compression heating experiments.

Tasks to be completed before performing the first compression heating test include fabricating the Guide and Mirror coils and fabricating the liner and its associated hardware. Translation tests without compression will be performed first, once the hardware has been assembled. These tests will characterize the performance of this new system and allow careful measurements to be made of the density, temperature, lifetime, stability, etc. of the FRCs as they are formed in the conical Theta coil and as they undergo translation into the liner. Assembly of the four-chord and single-chord interferometers must be completed to allow the density measurements to be made, and fabrication of the remaining magnetic diagnostics for the translation region must be carried out, as well. Once these tasks are performed, the first compression heating test will be performed.

VI. REFERENCES

- [1] M. Tuszewski, "Field Reversed Configurations," Nucl. Fusion, vol. 28, pp. 2033-2092, 1988.
- [2] J. M. Taccetti, T. P. Intrator, G. A. Wurden, et. al., "FRX-L: A Field-Reversed Configuration Plasma Injector for Magnetized Target Fusion," Rev. Sci. Instr., vol. 74, pp. 4314-4323, 2003.
- [3] T. P. Intrator, J. Y. Park, J. H. Degnan, et. al., "A High-Density Field Reversed Configuration Plasma for Magnetized Target Fusion," IEEE Trans. Plasma Sci., vol. 32, pp. 152-160, 2004.
- [4] G. A. Wurden, T. P. Intrator, S. Y. Zhang, et. al., "FRC Plasma Studies on the FRX-L Plasma Injector for MTF," to be published in Proc. from the 20th IAEA Fusion Energy Conference, Vilamoura, Portugal, 2004.
- [5] J. H. Degnan, D. Amdahl, A. Brown, et. al., "Full axial coverage radiography of deformable contact liner implosion performed with 8 cm diameter electrode apertures," in Proc. 15th IEEE International Pulsed Power Conference, 2005, pp 1239-1241.