

# PULSED BREAKDOWN CHARACTERISTICS OF HELIUM IN PARTIAL VACUUM IN KHZ RANGE\*

**K. Koppisetty<sup>§</sup>, H. Kirkici**

*Auburn University, Auburn, Auburn, AL, USA*

**D. L. Schweickart**

*Air Force Research Laboratory, Wright Patterson Air Force Base, OH-45433 USA*

## *Abstract*

This paper presents work on breakdown studies conducted in helium at partial vacuum conditions for a point-to-point electrode setup. A high frequency pulsed voltage signal is applied across the electrodes and the voltage-current characteristics are observed. The applied signal consists of a train of square pulses at frequencies of 50 kHz and 150 kHz with duty cycle varying from 10% to 50%. The rise/fall times of the pulses are less than 25 ns. These studies are conducted to understand and compare the role of pulse duration and the pulse repetition rate in electrical breakdown initiation at low pressure conditions. Data of voltage and current waveforms as a function of time, along with the light emission data collected by a PMT (Photo Multiplier Tube) are collected and breakdown voltage versus pressure, frequency and duty cycle are presented respectively.

## I. INTRODUCTION

Power systems and devices operating in partial vacuum environment are susceptible to partial discharges, corona, or volume discharges due to the partial vacuum conditions. PD and breakdown studies have been conducted on electrical equipment operating in such environments for decades. Electrical and electronic equipment used on high altitude flight vehicles must be designed to operate over a wide range of pressures and temperatures. Most of the studies conducted and techniques developed so far are for terrestrial equipment at atmospheric conditions. However, at low pressure or vacuum conditions, these techniques may not be applicable.

With increasing demand and a need for more sophisticated equipment onboard, the new generation of flight vehicles has higher power requirements and is likely to utilize higher voltages than the traditional 28 Vdc for onboard power distribution [1]. This can already be witnessed in some of the subsystems of the International

Space Station (ISS), which utilize 120 Vdc. The availability of switching power supplies operating at higher intermediate frequencies makes it important to consider the effects of these higher operating frequencies on corona and gas breakdown in partial vacuum conditions. In addition, it was observed in early flight programs that the existing data cannot be extrapolated for miniature systems with smaller electrode gaps operating at very low pressures [1].

Partial discharges are detrimental to a power system as they are constant sources of power loss and electrical noise (EMI). Furthermore, they can be a major problem at the component level, causing solid insulation deterioration and eventual breakdown. With the development of the newer aerospace vehicles using higher voltages than traditional 28 V dc power, the need for data to design higher voltage power systems is more desirable. Currently, there are several initiatives within the government agencies (such as NASA and Air Force), planning to use 270-volt distribution power [1]. Some sub-systems also use high frequency (in the 10s of kHz) voltages, for switched mode power conversion. In general, the corona or partial discharge initiation voltage is a function of several design and environmental parameters. The most important factors to be noted are the operation pressure, the electrode gap/geometry, and the frequency and voltage level of the applied power within a power system [4]. Commercial dc to dc voltage converters typically operate with intermediate frequencies in the range of 20 to 100 kHz. These voltages and frequencies are considered problem areas for corona and breakdown concerns in flight vehicles subjected to low pressure environments [5].

The earlier work presented in the literature suggests that the breakdown strength of certain gases falls off drastically at frequencies of 10s of kHz, which is not theoretically predictable [2]. Although there have been studies on the influence of frequency of the applied voltage signal on gas breakdown over specific frequency ranges, this behavior in the range below 1 MHz is not entirely studied. Our recent studies confirm that high frequency operation in partial vacuum could be a major

---

\* Work supported by the Universal Technology Corp., under contract to the Air Force Research Laboratory, Propulsion Directorate, contract number F33615-02-D-2299/DO-0024

<sup>§</sup> email: kalyan\_k@ieee.org

## Report Documentation Page

*Form Approved*  
*OMB No. 0704-0188*

Public reporting burden for the collection of information is estimated to average 1 hour per response, including the time for reviewing instructions, searching existing data sources, gathering and maintaining the data needed, and completing and reviewing the collection of information. Send comments regarding this burden estimate or any other aspect of this collection of information, including suggestions for reducing this burden, to Washington Headquarters Services, Directorate for Information Operations and Reports, 1215 Jefferson Davis Highway, Suite 1204, Arlington VA 22202-4302. Respondents should be aware that notwithstanding any other provision of law, no person shall be subject to a penalty for failing to comply with a collection of information if it does not display a currently valid OMB control number.

1. REPORT DATE <b>JUN 2007</b>	2. REPORT TYPE <b>N/A</b>	3. DATES COVERED <b>-</b>	
4. TITLE AND SUBTITLE <b>Pulsed Breakdown Characteristics Of Helium In Partial Vacuum In Khz Range</b>		5a. CONTRACT NUMBER	
		5b. GRANT NUMBER	
		5c. PROGRAM ELEMENT NUMBER	
6. AUTHOR(S)		5d. PROJECT NUMBER	
		5e. TASK NUMBER	
		5f. WORK UNIT NUMBER	
7. PERFORMING ORGANIZATION NAME(S) AND ADDRESS(ES) <b>Auburn University, Auburn, Auburn, AL, USA</b>		8. PERFORMING ORGANIZATION REPORT NUMBER	
9. SPONSORING/MONITORING AGENCY NAME(S) AND ADDRESS(ES)		10. SPONSOR/MONITOR'S ACRONYM(S)	
		11. SPONSOR/MONITOR'S REPORT NUMBER(S)	
12. DISTRIBUTION/AVAILABILITY STATEMENT <b>Approved for public release, distribution unlimited</b>			
13. SUPPLEMENTARY NOTES <b>See also ADM002371. 2013 IEEE Pulsed Power Conference, Digest of Technical Papers 1976-2013, and Abstracts of the 2013 IEEE International Conference on Plasma Science. IEEE International Pulsed Power Conference (19th). Held in San Francisco, CA on 16-21 June 2013., The original document contains color images.</b>			
14. ABSTRACT <b>This paper presents work on breakdown studies conducted in helium at partial vacuum conditions for a point-to-point electrode setup. A high frequency pulsed voltage signal is applied across the electrodes and the voltage-current characteristics are observed. The applied signal consists of a train of square pulses at frequencies of 50 kHz and 150 kHz with duty cycle varying from 10% to 50%. The rise/fall times of the pulses are less than 25 ns. These studies are conducted to understand and compare the role of pulse duration and the pulse repetition rate in electrical breakdown initiation at low pressure conditions. Data of voltage and current waveforms as a function of time, along with the light emission data collected by a PMT (Photo Multiplier Tube) are collected and breakdown voltage versus pressure, frequency and duty cycle are presented respectively.</b>			
15. SUBJECT TERMS			
16. SECURITY CLASSIFICATION OF:			17. LIMITATION OF ABSTRACT <b>SAR</b>
a. REPORT <b>unclassified</b>	b. ABSTRACT <b>unclassified</b>	c. THIS PAGE <b>unclassified</b>	
			18. NUMBER OF PAGES <b>4</b>
			19a. NAME OF RESPONSIBLE PERSON

concern when designing high altitude vehicle power systems [3], and that the breakdown voltage levels at high frequencies ( $< 1$  MHz) can indeed be lower than the dc breakdown voltage levels, at certain pressures.

This paper summarizes the current work by giving a brief description of the experimental setup, the procedures followed, and the preliminary results on breakdown characteristics of helium observed for pulsed voltages at 50 and 150 kHz under partial vacuum conditions for duty cycles varying from 10% to 50%.

## II. EXPERIMENTAL SETUP

The experimental setup consists of a vacuum chamber, high voltage power supply and a data acquisition system. The detailed description of the setup is given in [6]. The high voltage supply system consists of a signal generator with preset duty cycles (10-50%) and a high voltage DC source which are fed into a pulse generator to produce the output waveform with the desired characteristics. The electrode system consists of two stainless steel point electrodes placed 1 cm apart. These point electrodes are machined to a tip radius of 0.5 mm.

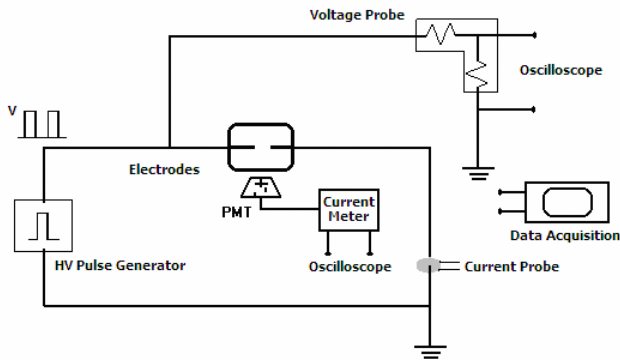

Figure 1. Schematic of the experimental setup.

The chamber is purged by first pumping out the gases, then filling with helium for each experiment set. Once the purge is completed, helium is then used as the operating gas. The chamber pressure is maintained constant throughout a particular set of breakdown events by controlling the gas inlet valve and the vacuum pump. The flow rate is maintained so as to keep the pressure constant. It should be noted, however, that the flow rate is low enough to ignore the effects of a flowing gas on the breakdown phenomenon. The breakdown experiments are conducted as pressure is varied from 0.1 torr up to 10 torr. The power supply is a PVX-4150 pulse generator, manufactured by Directed Energy Inc., with rising and falling edges under 25 ns. A square wave of desired duty cycle and frequency is fed into the pulse generator, where a variable repetitive pulsed high voltage is generated. The applied voltage is then gradually increased until a breakdown event is observed. For a particular frequency and duty cycle, at every pressure level, three successive

breakdown events are recorded and these voltages are averaged to form the data point for that particular pressure. The chamber is then flushed with helium before taking the next data set to avoid any contamination. The experimental setup, including the power source and the diagnostics, is shown in Figure 1 and the electrode setup is shown in Figure 2. Figure 3 shows the typical square pulses at 50 kHz with different duty cycles.

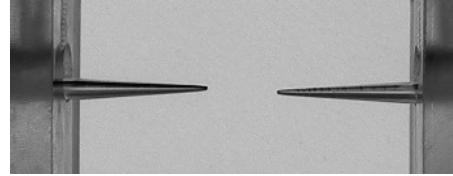

Figure 2. Point-to-Point electrode setup (tip radius – 0.5mm, electrode gap – 10mm).

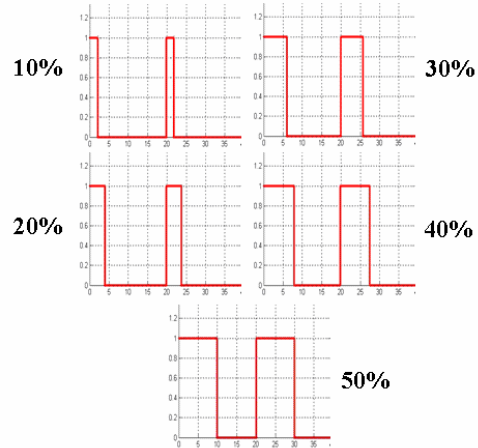

Figure 3. Typical applied voltage waveforms at 50 kHz for different duty cycles.

## III. EXPERIMENTAL RESULTS AND DISCUSSION

Our earlier studies on the high frequency breakdown of helium for the point-to-point configuration were reported previously [3, 6, 7]. These studies included using a dc shifted sinusoid and frequencies under 50 kHz and later by square pulse trains at frequencies ranging from 50 kHz to 200 kHz. It was shown that the breakdown voltage decreases as pressure increases, and around 1.5-2.0 torr, the breakdown curve seems to reach the lowest breakdown voltage. As presented in [6], the breakdown voltage characteristic for ac exhibits a pattern very similar to the typical Paschen curve for dc breakdown in Helium over the limited range investigated. Furthermore, for frequencies of 50, 100 and 150 kHz, the voltage minimum seems to occur around the 1.5-2.0 torr region [6]. This behavior can also be seen in Figure 4 where the breakdown voltages for dc and 50 kHz are shown in the pressure range of 0.1 to 10 torr of Helium for point-to-point electrode configuration. The breakdown voltage

variation with the applied frequency is studied for this geometry at a pressure of 1.2 torr. It is observed that the voltage decreases with increasing applied frequency, as observed in earlier work [6].

In the current setup, the applied voltage signal consists of a pulse train with rise and fall times under 25 ns and with duty cycles ranging from 10% to 50% at two different frequencies of 50 kHz and 150 kHz. Table 1 shows the duration ( $T_{High}$ ) for which the gaseous medium experiences the electric field in each of these cases.

As an example, Figure 6 shows the voltage waveform acquired at the breakdown for 1 torr and 50 kHz frequency with 20 % duty cycle. The optical emission captured by the PMT can also be seen. Once the breakdown voltage waveform data are collected for each pressure, the breakdown voltage versus pressure plots are generated for the combinations of the duty cycles and frequencies listed in Table 1.

**Table 1:**  $T_{High} / T_{Low}$  (in  $\mu s$ ) for 50 kHz and 150 kHz at various duty cycles (10% to 50%). The highlighted boxes show the cases with same values of  $T_{High}$ .

	50 kHz	150 kHz
10 %	2.00 / 18.00	0.67 / 9.00
20 %	4.00 / 16.00	1.33 / 5.33
30 %	6.00 / 14.00	2.00 / 4.67
40 %	8.00 / 12.00	2.67 / 4.00
50 %	10.00 / 10.00	3.33 / 3.33

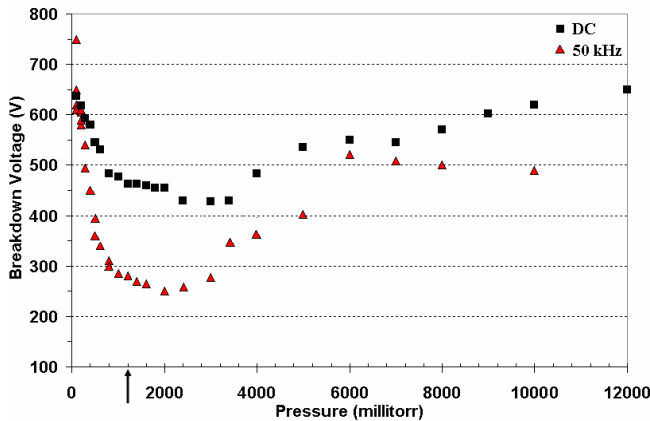

**Figure 4.** Breakdown voltage as a function of pressure at DC and 50 kHz (50% duty cycle)

The role of the duty cycle in each of these cases can be analyzed by comparing the values of  $T_{High}$  – the duration for which the signal stays on/high in a given signal cycle as shown in Table 1. To determine if the breakdown phenomenon depends (a) entirely on the duration for which the electric field is applied ( $T_{High}$ ) or (b) also on how much ‘relaxation time’ ( $T_{Low}$ ) the gaseous medium

experiences, two of the cases from the Table-1 with the same value of  $T_{High}$  are compared – for example: 50 kHz (10% duty cycle) and 150 kHz (30% duty cycle).

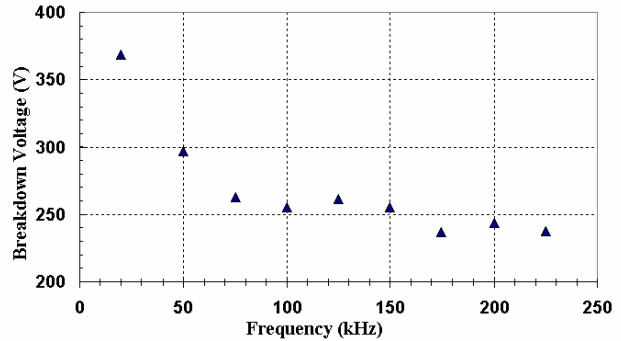

**Figure 5.** Breakdown voltage as a function of the applied signal frequency at 1.2 torr

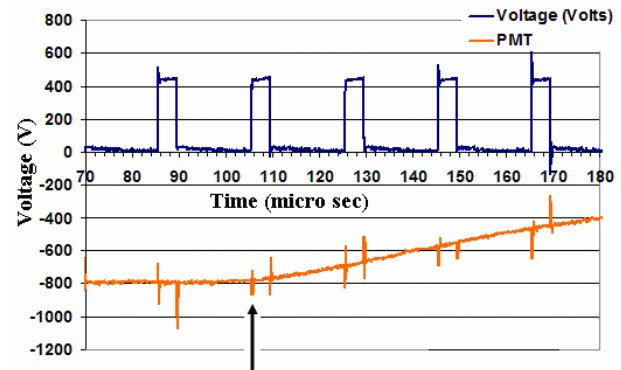

**Figure 6.** Voltage waveform acquired at the breakdown for 1 torr and 50 kHz frequency with 20 % duty cycle. Arrow indicates the breakdown initiation time.

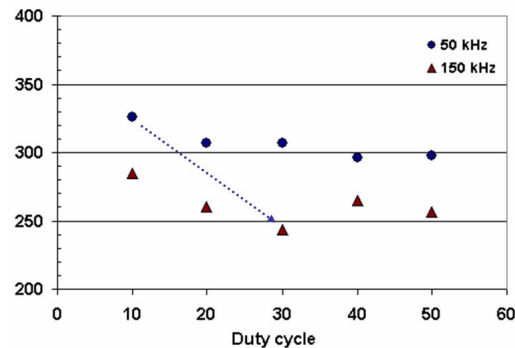

**Figure 7.** Breakdown voltage as a function of duty cycle for 50 kHz and 150 kHz applied frequency at 1.2 torr

The effect of the duty cycle for two signals with same  $T_{High}$  but different  $T_{Low}$  can be seen in Figure 7. The arrow in Figure 7 shows the decrease in the voltage level from 50 kHz (10%) to 150 kHz (30%) even though both the signals create the electric field for same duration ( $T_{High}$ ). Also, at this pressure, the breakdown voltage decreases as the duty cycle is increased from 10% to 50%. However,

since the DC breakdown voltage was found to be greater than the 50 kHz or 150 kHz case, on further increasing the duty cycle to 100% (DC signal) the breakdown voltage is expected to reach the dc level noticed in Figure 4.

#### IV. SUMMARY

We confirmed that the breakdown voltage steadily decreases as the signal frequency is increased from dc case to kHz range. A consistent fall in breakdown voltage is also observed as the duty cycle of the applied voltage is increased from 10% to 50% in the current configuration. However, an opposite trend is expected before reaching the 100% duty cycle (dc signal). Further studies are being conducted to determine the behavior at higher duty cycles and its cause. The data also suggests that the breakdown voltage versus pressure exhibits a pattern very similar to the Paschen curve for dc breakdown over this pressure range and the frequencies studied.

#### V. REFERENCES

- [1] W. G. Dunbar, D. K. Hall, H. Kirkici, G. Barry Hillard, D. L. Schweickart, "Spacecraft High Voltage Design Guidelines," a revision of *NASA-MFSC-STD-531*, (in pre-publication preparation).
- [2] W. Pfeiffer, "High-frequency voltage stress of insulation. Methods of testing," *Electrical Insulation, IEEE Transactions on [see also Dielectrics and Electrical Insulation, IEEE Transactions on]*, vol. 26, pp. 239-246, 1991.
- [3] H. Kirkici and K. Koppisetty, "Gaseous breakdown at high frequencies under partial vacuum," 2003, pp. 451-454.
- [4] J. M. Meek and J. D. Craggs, *Electrical breakdown of gases*. Chichester ; New York: Wiley, 1978.
- [5] K. Koppisetty, H. Kirkici, and D. L. Schweickart, "Partial vacuum breakdown of helium at 20 khz for point to-plane geometry," 2004, pp. 38-41.
- [6] K. Koppisetty, E. B. Sozer, H. Kirkici, and D. L. Schweickart, "Helium Breakdown Characteristics under 100 kHz Range Pulsed Voltages in Partial Vacuum for Point-to-point Electrode Geometry," 2006, pp. 112-115.
- [7] K. Koppisetty, H. Kirkici, M. Serkan, and D. L. Schweickart, "Optical emission characteristics of helium breakdown at partial vacuum for point to point geometry," 2005, pp. 47-50.