

# 15 KJ FLASH LAMP, POWER CONDITIONING UNIT DESIGNED FOR SAFETY, RELIABILITY & MANUFACTURABILITY\*

B. Merritt, G. Dreifuerst, G. James, S. Strickland, E. Tse

National Ignition Facility, Lawrence Livermore National Laboratory, 7000 East Avenue  
Livermore, CA, U.S.A.

## Abstract

A 15kJoule, Flash Lamp Power Conditioning Unit has been successfully designed, developed, and deployed in the National Ignition Facility (NIF) Pre-amplifier Modules (PAM). The primary design philosophy of this power conditioning unit (PCU) is safety, reliability, and manufacturability. Cost reduction over commercially equivalent systems was also achieved through an easily manufactured packaging design optimized to meet NIF requirements. While still maintaining low cost, the PCU design includes a robust control system, fault diagnostic system, and safety features. The pulsed power design includes 6 PFN modules, each including a dual series injection trigger transformer, that drive a total of 12 flash lamp loads. The lamps are individually triggered via a 20kV pulse produced by a 1kV, MCT switched capacitive discharge unit on the primary side of the trigger transformer. The remote control interface includes an embedded controller that captures flash lamp current wave forms and fault status for each shot. The embedded controller provides the flexibility of remotely adjusting both the main drive voltage from 1.6 to 2.5 kV and the trigger voltage from 0 to 20 kV.

## I. PRODUCTION STATUS

Four prototypes were built at LLNL and evaluated with flash lamp loads. The evaluation included testing the PCU through fault scenarios. Through this effort a design was successfully developed to meet LLNL requirements.

A contract was then awarded to Raytheon to build 57 production units. Forty-eight units have been successfully acceptance tested and installed in NIF. This completes the PCU installation for NIF. Thirty-three of these units have been commissioned to-date with over 2200 NIF laser shots.

Three other production units are in service in offline facilities and six more units are expected to be ready for shipment to other institutions in August 2007.

## II. BACKGROUND

The PCU delivers the pulsed power required by the NIF Pre-amplifier Module (PAM) laser system as shown in Figure 1. The PAM provides laser light amplification for each of the 48 Quads in NIF. The PAM receives a nanojoule level laser beam from the Master Oscillator and produces a multi-joule level beam that is split 4 ways before propagating to the Main Laser Amplifiers. Most of the Gain is realized in the regeneration section of the PAM. A gain of 10000 is realized by the Multi Pass Amplifier (MPA) shown on the left side of Figure 1. The output of the power conditioning unit (PCU) provides nominally 1.25 kJ pulses to each of 12 flash lamps in the MPA through 16 feet of triaxial cable. These cables are connected to flash lamps through the Top Hat assembly located on top of the PAM.

The Top Hat serves as a junction box, houses the HV cable interlock Printed Wiring Board (PWB), and provides a clean room barrier to the internals of the PAM. Silicone insulated leads provide connections to the flash lamp terminals.

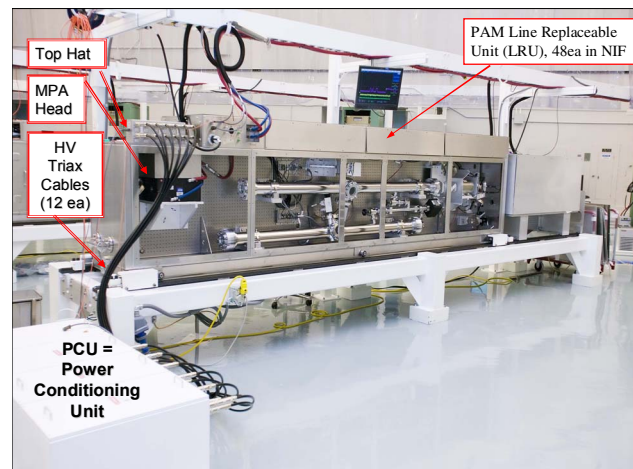

Figure 1. The PCU provides pulsed electrical power to the Multi Pass Amplifier within the Pre-amplifier Laser System.

## III. PULSED POWER REQUIREMENTS

\* This work was performed under the auspices of U.S. Department of Energy National Nuclear Security Administration by Lawrence Livermore National Laboratory under Contract W-7405-Eng-48.

## Report Documentation Page

*Form Approved  
OMB No. 0704-0188*

Public reporting burden for the collection of information is estimated to average 1 hour per response, including the time for reviewing instructions, searching existing data sources, gathering and maintaining the data needed, and completing and reviewing the collection of information. Send comments regarding this burden estimate or any other aspect of this collection of information, including suggestions for reducing this burden, to Washington Headquarters Services, Directorate for Information Operations and Reports, 1215 Jefferson Davis Highway, Suite 1204, Arlington VA 22202-4302. Respondents should be aware that notwithstanding any other provision of law, no person shall be subject to a penalty for failing to comply with a collection of information if it does not display a currently valid OMB control number.

1. REPORT DATE <b>JUN 2007</b>	2. REPORT TYPE <b>N/A</b>	3. DATES COVERED <b>-</b>			
4. TITLE AND SUBTITLE <b>15 KJ Flash Lamp, Power Conditioning Unit Designed For Safty, Reliability &amp; Manufacturability</b>		5a. CONTRACT NUMBER			
		5b. GRANT NUMBER			
		5c. PROGRAM ELEMENT NUMBER			
6. AUTHOR(S)		5d. PROJECT NUMBER			
		5e. TASK NUMBER			
		5f. WORK UNIT NUMBER			
7. PERFORMING ORGANIZATION NAME(S) AND ADDRESS(ES) <b>National Ignition Facility, Lawrence Livermore National Laboratory, 7000 East Avenue Livermore, CA, U.S.A.</b>		8. PERFORMING ORGANIZATION REPORT NUMBER			
9. SPONSORING/MONITORING AGENCY NAME(S) AND ADDRESS(ES)		10. SPONSOR/MONITOR'S ACRONYM(S)			
		11. SPONSOR/MONITOR'S REPORT NUMBER(S)			
12. DISTRIBUTION/AVAILABILITY STATEMENT <b>Approved for public release, distribution unlimited</b>					
13. SUPPLEMENTARY NOTES <b>See also ADM002371. 2013 IEEE Pulsed Power Conference, Digest of Technical Papers 1976-2013, and Abstracts of the 2013 IEEE International Conference on Plasma Science. IEEE International Pulsed Power Conference (19th). Held in San Francisco, CA on 16-21 June 2013., The original document contains color images.</b>					
14. ABSTRACT <b>A 15kJoule, Flash Lamp Power Conditioning Unit has been successfully designed, developed, and deployed in the National Ignition Facility (NIF) Preamplifier Modules (PAM). The primary design philosophy of this power conditioning unit (PCU) is safety, reliability, and manufacturability. Cost reduction over commercially equivalent systems was also achieved through an easily manufactured packaging design optimized to meet NIF requirements. While still maintaining low cost, the PCU design includes a robust control system, fault diagnostic system, and safety features. The pulsed power design includes 6 PFN modules, each including a dual series injection trigger transformer, that drive a total of 12 flash lamp loads. The lamps are individually triggered via a 20kV pulse produced by a 1kV, MCT switched capacitive discharge unit on the primary side of the trigger transformer. The remote control interface includes an embedded controller that captures flash lamp current wave forms and fault status for each shot. The embedded controller provides the flexibility of remotely adjusting both the main drive voltage from 1.6 to 2.5 kV and the trigger voltage from 0 to 20 kV.</b>					
15. SUBJECT TERMS					
16. SECURITY CLASSIFICATION OF:			17. LIMITATION OF ABSTRACT <b>SAR</b>	18. NUMBER OF PAGES <b>6</b>	19a. NAME OF RESPONSIBLE PERSON
a. REPORT <b>unclassified</b>	b. ABSTRACT <b>unclassified</b>	c. THIS PAGE <b>unclassified</b>			



The pulsed power requirements for the PCU are mainly derived from the fundamental flash lamp operating specifications and are as follows:

- -2500V maximum Charge voltage (nominal operating range is -1600 to -2200V).
- Single stage LC pulse forming network that is critically damp with approximately 0.5 Ohm lamp impedance for each of the 12 lamps.
- Pulse width ( $3\sqrt{LC}$ ) of 782 us at 10% of the peak current.
- Limit fault energy to any one lamp to much less than the explosion rating (7104 Joules).
- Trigger voltage adjustable from 0 to +20 kV (nominal is 15 kV).
- Maximum repetition rate of 1 shot per 5 minutes.
- Shot-to-shot Voltage stability of 0.27% RMS.

#### IV. SAFETY REQUIREMENTS

The safety requirements are equally important and are as follows:

- Less than 50 Volt touch potential on any exposed surfaces.
- Discharge stored energy in less than 10 seconds.
- Enclosure must contain flying debris and spilled oil from highly unlikely, but possible capacitor explosions.
- Covers limiting access to potentials, above 50V and not limited to less than 5 mA, or stored energies greater than 10 Joules, require at least two fasteners requiring a tool for removal.
- Safety Contactor interlocked to facility safety permissive.
- Laser Beam Lock-out feature.

#### V. DESIGN CONCEPT

The PCU design philosophy focused on lowering costs, improving reliability, and adding data capabilities over what is commercially available.

The architecture of the fundamental flash lamp PFN is shown in Figure 2 and includes the following:

- Single stage LC PFN with Dual Series Injected trigger transformer whose saturated secondary inductance provides the L. The 20:1 Turns Ratio provides up to a 20 kV trigger voltage (programmable).
- Number of PFNs has been chosen to be six to lower costs while keeping fault conditions manageable.
- Only six HV capacitors and six transformers with dual secondaries.
- If only one lamp fires, it only sees a maximum of 2x the energy (2.5 kJ) as opposed to 12x (the full 15 kJ).
- Make the capacitance 1000 uF (500 uF per lamp).
- Then  $L = (T_{pw}^2/3)/C = 136 \mu\text{H}$ .

- HV Triax cables with a connector interlock PWB in PAM Top Hat.

Triax provides safe touch potentials and interlocks ensure the cables are connected.

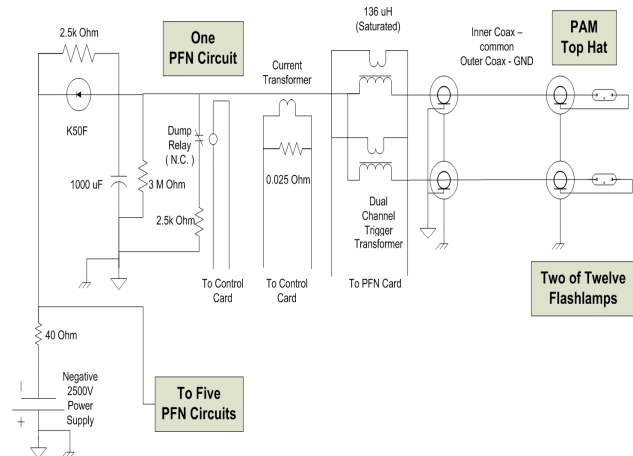

**Figure 2.** Simplified schematic of the PFN circuit driving a lamp pair.

Figure 2 shows the pulsed power circuit for one lamp pair. A single charging supply charges all 6 PFN capacitors through a 40 Ohm resistor. The 40 Ohm resistor protects HVPS rectifiers against output shorts. The 2.5 kOhm dump circuit discharges the 1000 uF capacitor within 10 seconds. A 2 MOhm resistor internal to the capacitor and the 3 MOhm resistor in the HV divider provide redundant passive discharge paths. The series connected 2.5 kOhm resistor provides a redundant discharge path to the dump circuits in the other 5 PFN's. Should the dump resistor or relay fail, the capacitor discharges through the resistors of the other 5 dump circuits. The series connected resistor also provides fault isolation from the other PFN capacitors in the event the capacitor fails short. The diode bypasses the resistor during normal charging operation. This reduces the power dissipation and voltage drop while the capacitor is being charged.

The current transformer provides a current signal of a lamp pair for fault diagnostics.

The dual series injection transformer provides up to 20 kV, 5 us pulses to the flash lamp pair through the two secondaries. The output pulses are created through 20:1 step-up transformer secondaries with up to a 1000V primary voltage pulse. At this time the flash lamps breaks down to a low impedance, effectively placing the secondary windings directly across the charged PFN capacitor. These secondaries saturate after being at the charge voltage for approximately 10 us at which time the inductance changes from approximately 10 mH to 136 uH discharging the capacitor into the flash lamp. This produces the critically damped waveform shown in Figure 11 with a  $3\sqrt{LC} = 782 \mu\text{s}$  pulse width at the 10%  $I_{max}$  points. The negative charge voltage provides volt-seconds saturation and resets the core for the next positive trigger pulse.

The primary voltage of the trigger transformer is controlled through a high-voltage power supply that is remotely programmable through the embedded controller control interface.

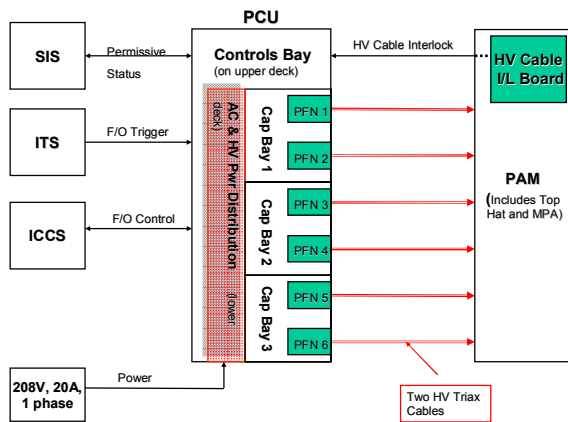

**Figure 3.** System Block Diagram of the PCU

A system overview of the PCU is shown in Figure 3. It depicts the facility interfaces and the PCU enclosure architecture. The facility interfaces are:

- High-voltage (HV) cable interlock board provides a permissive back to the PCU when all HV connectors are engaged.
- Safety Interlock System (SIS) provides a permissive to the safety contactor within the PCU. Confirmation of the contactor state is provided as feedback to the SIS system.
- A fiber optically transmitted trigger is provided from the NIF timing system.
- A Duplex fiber provides communication with the PCU embedded controller.
- 208VAC, single phase power from a 20 amp service is provided through a quick-disconnect Hubble connector.

The PCU enclosure includes four bays or compartments. Three of these bays are capacitor bays that include two each PFN assemblies and the fourth bay is the controls bay that includes a lower deck for power distribution and an upper deck for low voltage controls. The PCU design includes 4 types of Printed Wiring Boards (PWB) as described below. The bullets below each listing describes its primary functions or components:

- One Trigger PWB per PFN located in the capacitor bays (a total of 6 boards)
  - Metal-Oxide Controlled Thyristor (MCT) Trigger Circuit
  - Dump Circuit
  - Current Monitor
  - Voltage monitor

- One Control & Interface PWB in the upper deck of the controls bay
  - Embedded controller
  - Data Acquisition
  - Remote control interface
  - Safety Interlock System (SIS) interface
  - Timing signal handling
- One HV Fanout PWB in the lower deck of the controls bay
  - Fan-out for -2.5 kV Charging power supply
  - Fan-out and monitoring for 1 kV Trigger power supply
  - Includes the 1 kV Trigger power supply with current limiting resistors
- One HV Cable Interlock PWB in PAM Top Hat

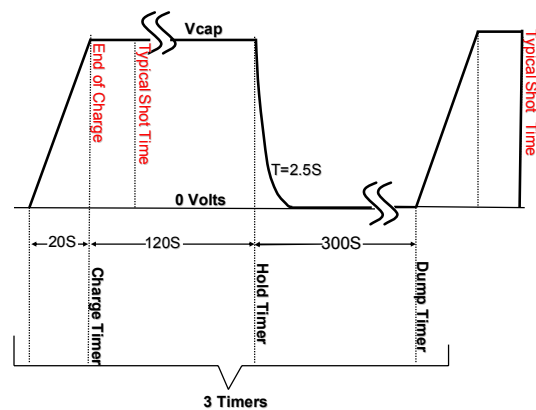

**Figure 4.** Capacitor Charging Voltage profile

Critical components within the PCU are protected with three timers whose functions are described in the bulleted paragraphs below. The timer durations and sequencing through the charge, hold, and dump operations are shown on the capacitor charge voltage profile in Figure 4. All of these timers are realized in hardware on the control and interface boards.

- Charge Timer aborts charging and drops dumps if charge time exceeds 20 seconds usually indicating a component fault in the HV circuit.
- Hold Timer drops dumps if PCU is not fired within 120 seconds minimizing the time that HV capacitors are at voltage.
- Dump Timer prevents operator from recharging within 300 seconds preventing overheating of dump resistors and dump relays. The dump timer restarts after any charge and dump, charge and hold, and normal charge and fire operations.

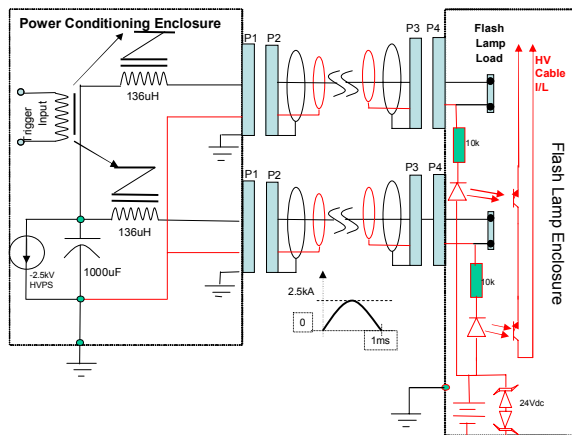
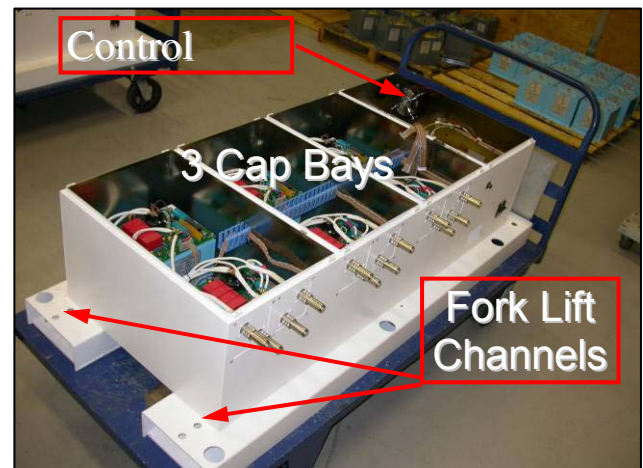

**Figure 5.** HV Cable Interlock Circuit shown for a lamp pair.

The red line connections in Figure 5 show the sense circuits that are completed when each connector is engaged at each end of the cables. The circuit is completed through the intermediate contacts for the inner shield at each end of the HV Triax, when both cable/connector ends are engaged. The cable engagement of both ends completes the 24V circuit through the series connection of 10 kOhms and an opto-coupler LED to a ground picked up within the PCU. With this circuit complete a few milliamps of current flows through LED turning on the opto-coupler transistor. When all 12 transistors are turned on a permissive is provided to the PCU. These sense circuits are located on the HV Cable interlock (I/L) board located within the Top Hat. Robust protection against HV transients is included on the HV Cable I/L board.

The enclosure packages the PCU so that it can be installed in NIF as a Line Replaceable Unit (LRU). See Figure 6. The enclosure's base or lifting frame incorporates seismic requirements and is designed to be used with a fork lift. The architecture includes four bays in a single, welded structure with following features:

- Three for PFNs (two lamps each)
  - Each PFN bay's stored energy will stay under LLNL's ES&H Manual 10 kJ limit (2x3.1 kJ)
  - Lower 1.5 inch is seam welded to provide secondary containment of the capacitor's dielectric fluid in the event that any of the capacitor cases rupture
- One for OEM HV power supply and controls
  - Controls are located in Low Voltage section to allow diagnostic testing without HV hazard
  - 208 V circuitry and HVPS under separate metal cover for personnel safety
- Each bay has it's own top-access lid with four fasteners

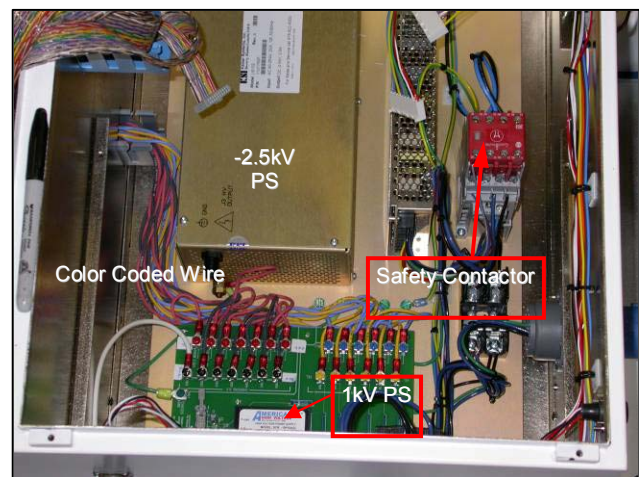

**Figure 6.** PCU Enclosure with the 4 access covers removed.

The four bays of the PCU with covers off are shown in Figure 6. The three capacitor bays, control deck, and fork lift channels are identified..

The blue panduit cable tray runs through the top/central section of the three capacitor bays providing a highway for the control signals to each PFN Trigger Board. The control signals are provided through 20 wire ribbon cable. An identical gray panduit cable tray runs through the bottom/central section of the three capacitor bays providing a highway for the HV signals to each PFN Trigger Board.

Below the controls deck is the PWR Deck shown in Figure 7. The HV charging supply, the HV Trigger supply, safety contactor, and HV color coded wires are identified. This drop-in assembly can be assembled on the bench and then bolted into the enclosure.



**Figure 7.** PWR Deck (located below control deck)

Color coded wires and terminals for each HV output are distributed from the HV Fan out card to each PFN trigger board. The color coded wires and terminals greatly enhanced the ease of wiring to the subassemblies and wire inspections.

The HV Fan Out board includes current limiting resistors to keep the outputs to the PFN Trigger board below the 5 mA safety limit. This permits trouble shooting of the trigger circuits with the covers off provided that the capacitors have been verified as discharged and the HVPS circuit breaker has been locked off.

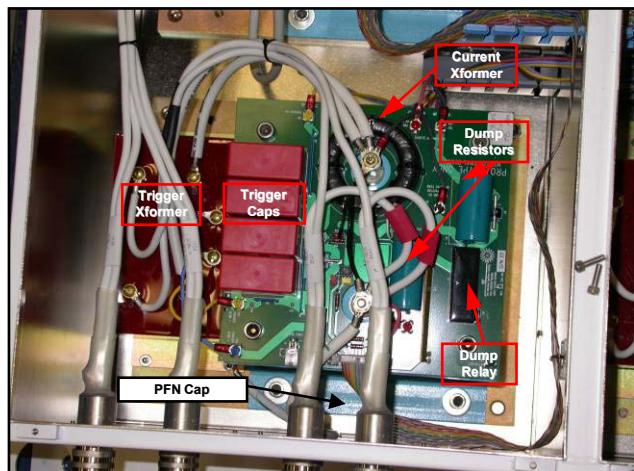

**Figure 8.** PFN Assembly includes Trigger Board, Trigger Transformer, and Capacitor.

A single PFN assembly is shown in Figure 8. This is a drop-in assembly that can be assembled and wired on the bench and then bolted into the enclosure. The HV panel mount connectors mount from the inside of the enclosure. The PFN assembly includes only three sub-assemblies: transformer, capacitor, and Trigger Board. The PFN Trigger board contains all of the small discrete components along with the Trigger circuits. These circuits include the Dump Circuits, Current Transformer, Charging HV Fan Out circuits, and cable interlock circuits. The Current transformer, dump resistor, dump relay, and trigger circuit capacitors are identified in Figure 8. The MCT is on the left hand side of the board, out of sight, under the HV wire. The board is laid out such that the trigger circuitry is on the left hand side and charging and dump circuits are on the right side of the circuit. Instrumentation/Interlock traces go up the center.

The cable interlock included with this PFN Trigger board prevents the capacitors from charging if the control cable assembly is not connected. The PFN Trigger board is mounted intimately with the capacitor on its' tapped lifting-holes. Holes are provided on the PWB to allow the bushing of the capacitor to protrude through the aperture of the current transformer.

An offline test facility is used to conduct acceptance testing of PCU's, reliability testing of PCU's, and reliability testing of MPA heads (See Figure 9). This test setup includes an actual flash lamp load to provide authentic performance data. This facility has been

instrumental in fault and reliability testing with over 20,000 shots on PCU's and flash lamps.

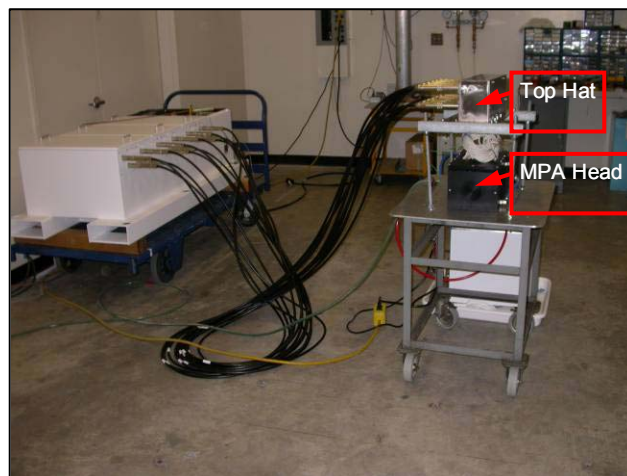

**Figure 9.** Offline test facility includes the actual flash lamp load.

## VI. DATA ACQUISITION SYSTEM

The diagnostic system utilizes the current transformer and voltage divider on each PFN trigger board to monitor the performance of the flash lamps. The lamp current signal for each PFN is used to diagnose normal operation, lamp no-fires, faults outside of PFN, or lamp prefires. The voltage monitors for each PFN provides the capacitor voltage prior to each shot, a verification that the capacitor voltage discharges within 10 seconds, and a verification that the capacitor has completely discharged after a shot. Upon diagnosing an abnormal condition the control room operator is notified on the Graphic User Interlace (GUI) shown in Figure 10. Under the Faults title on the GUI the shot status for each PFN is indicated. This indicator turns red under abnormal conditions.

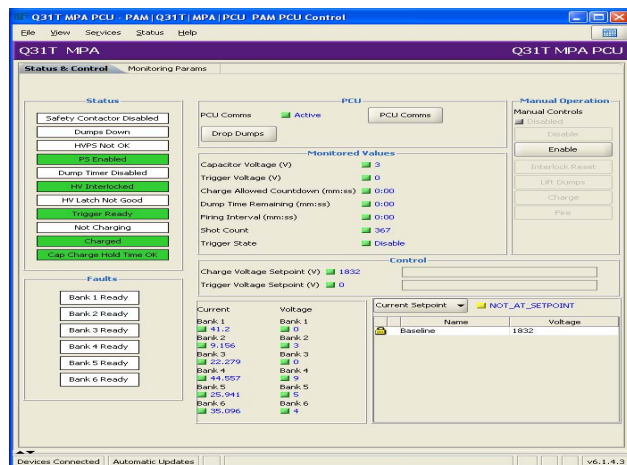

**Figure 10.** PCU Graphical User Interface

The current wave form for each lamp pair is archived and displayed under the Monitoring Parameters tab (See

Figure 11). These waveforms along with other data are retained for confirmation of Shot performance and Archived for Post shot analysis and trending.

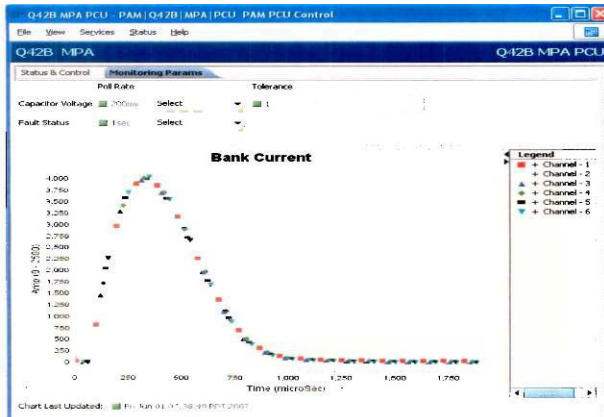

**Figure 11.** Current waveforms for all 6 lamp pair currents are displayed under the Monitor Parameters Tab.

The waveforms for all 6 lamps overlap right on top of each other under normal conditions. The embedded controller is programmed with a Lamp Fault algorithm that will indicate a bank fault when the current is outside + 20% of nominal. This fault will be displayed on the Faults panel of the GUI for the corresponding PFN channel.

## VII. SUMMARY

The PCU includes a number of safety and equipment protection features. The safety features include:

- 10 kJ partition and low voltage partition
- 3 Timers
- Triaxial Cable and associated Interlock
- Redundant dump circuits and passive discharge paths
- Capacitor voltage monitoring

The design is inherently reliable with the hold time limit on the capacitor voltage, low parts count, and robust margins. The PCU's have now accumulated over 20,000 shots to date. Only seven failures have occurred and are listed below:

- PFN Trigger Board: HV Voltage Divider (1) and MCT (1)
- Control & Interface Board: Zapped Disk-on-chip (1)
- Electrical/Optical Media converter: 1 each
- HV Triax Cable failures: 3 each

With the exception of the last failures most of them are thought to be infant mortality type failures. From the failure analysis reports for the first two cable failures it is believed that the connectors were not completely engaged prior to operation. It is also possible that some cable sets are out of mechanical tolerance. Our path forward is to screen all of the cables for appropriate tolerances, visually

inspect all of the installations, and include connector engagement checks in the installation procedures.

The PCU design was demonstrated to have good manufacturability by the virtue of the subcontractors being able to achieve 3 times the requested production rate. This is attributed to:

- Drop-In Assemblies w/Low Parts Count
- All small discreet parts are integrated onto a PWB
- Color coded HV wires and associated PWB terminals aids wiring, QA checks, & rewiring of replaced modules

## VIII. REFERENCES

[1] B. Merritt, G, Dreifuerst, and G. James, "PAM PCU Design Status" LLNL Internal Document, September 28, 2005

[2] B. Merritt, G, Dreifuerst, and G. James, S. Strickland "Final Design and Production Readiness Review", LLNL Internal Document, December 16, 2005

[3] B. Merritt and G, Dreifuerst, "Safety Note", LLNL Internal Document, NIF-5016610, 03/07/2007.

[4] B. Merritt, G, Dreifuerst, and G. James, Presentation view graphs for "15 kJ Flash Lamp, Power Conditioning Unit Designed for Safety, Reliability, & Manufacturability", UCRL-PRES-231831, 16th IEEE Pulsed Power Conference Albuquerque NM, June 22, 2007

[5] PCU Requirements, ECR10785, NL 112, LLNL Internal Document