

# STATUS OF THE NIF POWER CONDITIONING SYSTEM\*

**P. A. Arnold, S.D. Hulsey, G.T. Ullery, D.E. Petersen, D.L. Pendleton,  
C.W. Ollis, M.A. Newton**

*Lawrence Livermore National Laboratory, 7000 East Avenue  
Livermore, CA, U.S.A.*

**T. Harwell, D. Cordoza, L. Hadovski**

*Raytheon Technical Services, 1650 Industrial Boulevard  
Chula Vista, CA, U.S.A.*

## *Abstract*

The NIF Power Conditioning System provides the pulsed excitation required to drive flashlamps in the laser's optical amplifiers. Modular in design, each of the 192 Main Energy Storage Modules (MESMs) storage up to 2.2 MJ of electrical energy in its capacitor bank before delivering the energy to 20 pairs of flashlamps in a 400  $\mu$ s pulse (10% power points). The peak current of each MESM discharge is 0.5 MA.

Production, installation, commissioning and operation of the NIF Power Conditioning continue to progress rapidly, with the goals of completing accelerated production in late 2007 and finishing commissioning by early 2008, all the while maintaining an aggressive operations schedule. To date, more than 80% of the required modules have been assembled, shipped and installed in the facility, representing more that 240 MJ of stored energy available for driving NIF flashlamps. The MESMs have displayed outstanding reliability during daily, multiple-shift operations.

## **I. INTRODUCTION**

The Power Conditioning System of the National Ignition Facility at the Lawrence Livermore National Laboratory (LLNL) is rapidly approaching the end of its production phase with the ultimate goal of commissioning and operating all elements of the 400 MJ bank by the end of 2007. Module installation, activation and commissioning are progressing in near lockstep with production. Meanwhile, NIF relies on more than 145 commissioned modules to support two-shift-per-day operations.

To date, more than 80% of the modules have been fabricated and installed in the facility. Production rate at Raytheon Technical Services (Chula Vista, CA) is averaging 7 modules per month.

## **II. BACKGROUND**

The National Ignition Facility (NIF) is a laser fusion driver whose construction has spanned the last several years. Conventional facilities work has ended and the main emphasis has shifted to "filling the building" with hardware, completing the implementation and testing of the software and making the entire facility operational to achieve a stated goal of beginning fusion experiments by 2010. Among the key systems in NIF is the Power Conditioning System (PCS). PCS provides the pulsed excitation required to drive the nearly 8000 xenon flashlamps in the laser's optical amplifiers—the two-pass power amplifier and the four-pass main amplifier. A total of 192 PCS modules will be installed by the end of 2007 to provide the gain for the facility's 192 beams. Each module is capable of storing up to 2.2 MJ of electrical energy before delivering the energy to 20 pairs of flashlamps in a 400  $\mu$ s pulse (10% power points). The peak current of each Main Energy Storage Module (MESM) discharge exceeds 0.5 MA. Thus, a "system" shot will be characterized by the delivery of ~400 MJ of electrical energy, with a peak power of 1.25 TW and a total peak current of ~100 MA.<sup>1,2,3</sup>

The modules deployed in NIF represent the culmination of extensive design and development efforts on the parts of groups from LLNL, Sandia National Laboratories, and numerous industrial partners, including L-3 (Physics International), Ktech, American Control Engineering, General Atomics, UVC, ICAR and Raytheon.

The required quantity of modules and the nature of the module design led to a decision to place the fabrication, initial testing and installation of the system in the hands of an external vendor. These considerations opened the door for vendors with demonstrated expertise with volume production of high-tech hardware in addition to traditional pulsed power vendors. After a competitive bid process the contract was awarded to Raytheon Technical Services of Chula Vista CA, a vendor with a history of production work for the US military, with particular emphasis on large systems for the US Navy.

## **III. REQUIREMENTS**

NIF is a "target shooter," designed to operate three shifts per day, seven days a week and shoot up to 6 times

\* This work performed under the auspices of the U.S. Department of Energy by the University of California Lawrence Livermore National Laboratory under Contract No. W-7405-Eng-48.

## Report Documentation Page

*Form Approved*  
*OMB No. 0704-0188*

Public reporting burden for the collection of information is estimated to average 1 hour per response, including the time for reviewing instructions, searching existing data sources, gathering and maintaining the data needed, and completing and reviewing the collection of information. Send comments regarding this burden estimate or any other aspect of this collection of information, including suggestions for reducing this burden, to Washington Headquarters Services, Directorate for Information Operations and Reports, 1215 Jefferson Davis Highway, Suite 1204, Arlington VA 22202-4302. Respondents should be aware that notwithstanding any other provision of law, no person shall be subject to a penalty for failing to comply with a collection of information if it does not display a currently valid OMB control number.

1. REPORT DATE <b>JUN 2007</b>			2. REPORT TYPE <b>N/A</b>			3. DATES COVERED <b>-</b>		
4. TITLE AND SUBTITLE <b>Status Of The Nif Power Conditioning System</b>						5a. CONTRACT NUMBER		
						5b. GRANT NUMBER		
						5c. PROGRAM ELEMENT NUMBER		
6. AUTHOR(S)						5d. PROJECT NUMBER		
						5e. TASK NUMBER		
						5f. WORK UNIT NUMBER		
7. PERFORMING ORGANIZATION NAME(S) AND ADDRESS(ES) <b>Lawrence Livermore National Laboratory, 7000 East Avenue Livermore, CA, U.S.A.</b>						8. PERFORMING ORGANIZATION REPORT NUMBER		
9. SPONSORING/MONITORING AGENCY NAME(S) AND ADDRESS(ES)						10. SPONSOR/MONITOR'S ACRONYM(S)		
						11. SPONSOR/MONITOR'S REPORT NUMBER(S)		
12. DISTRIBUTION/AVAILABILITY STATEMENT <b>Approved for public release, distribution unlimited</b>								
13. SUPPLEMENTARY NOTES <b>See also ADM002371. 2013 IEEE Pulsed Power Conference, Digest of Technical Papers 1976-2013, and Abstracts of the 2013 IEEE International Conference on Plasma Science. IEEE International Pulsed Power Conference (19th). Held in San Francisco, CA on 16-21 June 2013., The original document contains color images.</b>								
14. ABSTRACT <b>The NIF Power Conditioning System provides the pulsed excitation required to drive flashlamps in the lasers optical amplifiers. Modular in design, each of the 192 Main Energy Storage Modules (MESMs) storage up to 2.2 MJ of electrical energy in its capacitor bank before delivering the energy to 20 pairs of flashlamps in a 400 is pulse (10% power points). The peak current of each MESM discharge is 0.5 MA. Production, installation, commissioning and operation of the NIF Power Conditioning continue to progress rapidly, with the goals of completing accelerated production in late 2007 and finishing commissioning by early 2008, all the while maintaining an aggressive operations schedule. To date, more than 80% of the required modules have been assembled, shipped and installed in the facility, representing more that 240 MJ of stored energy available for driving NIF flashlamps. The MESMs have displayed outstanding reliability during daily, multiple-shift operations.</b>								
15. SUBJECT TERMS								
16. SECURITY CLASSIFICATION OF:				17. LIMITATION OF ABSTRACT	18. NUMBER OF PAGES	19a. NAME OF RESPONSIBLE PERSON		
a. REPORT	b. ABSTRACT	c. THIS PAGE						
<b>unclassified</b>	<b>unclassified</b>	<b>unclassified</b>		<b>SAR</b>	<b>5</b>			

per day. As such, performance and reliability are paramount. Requirements flow down to the individual systems, with PCS requirements largely derived from and driven by laser goals for performance, lifetime and availability. Top level requirements for the Power Conditioning System are captured in Table 1.

**Table 1.** PCS System Requirements

Parameter	Value/Range
Number of modules	192 with potential for expansion to 208
Nominal energy stored	400 MJ
Output pulsewidth	400 $\mu$ s
Charge voltage	24 kV
Shot-to-shot Energy repeatability	<1% rms
Temporal energy spread	<2 $\mu$ s across all modules in a capacitor bay
Minimum Amplifier gain	5%/cm
Operational lifetime	30 years with maintenance
Reliability	>92%

Individual module requirements are, in turn, derived from system requirements with additional requirements based on operational, safety and functional needs of the system. Table 2 delineates primary module and module component requirements. In keeping with NIF's overall architecture employing Line Replaceable Units, subcomponents of the modules are intended to be replaced rather than repaired *in situ*.

**Table 2.** Individual module/component requirements.

Subsystem	Parameter	Value/Range
Main energy storage module	Capacitance	6.0 to 7.2 mF (20 – 24 capacitors)
	Nominal charge voltage	24 kV
	Dwell time at charge voltage	<15 s
	Reversal	< 15%
	Main switch	Peak current
Power supplies	Action	67 MJ/ $\Omega$ (max)
	Coulomb transfer	>280 kC ( per refurbishment)
	Charge voltage	24 kV (nominal), 26 kV (max)
Pre-ionization/Lamp Check circuit	Charge Rate	25 kJ/s
	Regulation	0.05%
Subsystem	Parameter	Value/Range
Pre-ionization/Lamp Check circuit	Capacitance	130 $\mu$ F
	Charge voltage	26 kV

Dump circuits	Discharge time	<10 seconds (with redundant dumps)
Capacitors	Capacitance	290 $\mu$ F, -0+10%
	ESR	<15 m $\Omega$

#### IV. FUNCTIONAL DESCRIPTION

NIF is organized into multiple sub-groupings. The facility comprises two laser bays, with 96 beams each. Each laser bay includes 2 clusters of 48 beams. In turn, each cluster is composed of 6 bundles, with the bundle representing the fundamental NIF organization unit, the primal cell whose functionality—both hardware and software—is replicated 24 times throughout the facility. A power conditioning bundle is a group of eight main energy storage modules, the number required to drive flashlamps for single bundle of laser beams. Each bundle of power conditioning units has all the required controls hardware and software, utilities and other elements of the infrastructure required to operate as a completely separate and autonomous unit. (While it is possible to operate a subset of a bundle, the emphasis is on operating this grouping as a unit.)

MESMs occupy four independent 1150 m<sup>2</sup> capacitor bays in the facility, with each supporting a given cluster (i.e., 48 beamlines). Each capacitor bay nominally houses 6 bundles/48 power conditioning modules. Provisions have been made for an additional module in each bundle should future power requirements dictate additional optical energy. One of three completed capacitor bays is depicted in Figure 1.



**Figure 1.** Completed Capacitor Bay with 48 modules, capable of storing ~100 MJ of electrical energy for flashlamps.

The MESM design is the latest iteration in the evolution of flashlamp drivers deployed in laser systems at LLNL. The general direction has been one of reduction of the number of components and an increase in energy and energy density, largely driven by requirements for increased reliability and reduced costs. By following this strategy and employing innovative hardware, NIF has been able to drive the cost of stored electrical energy down to ~\$0.20/J. Comparative data for NIF and its predecessors at LLNL are captured in Figure 2.

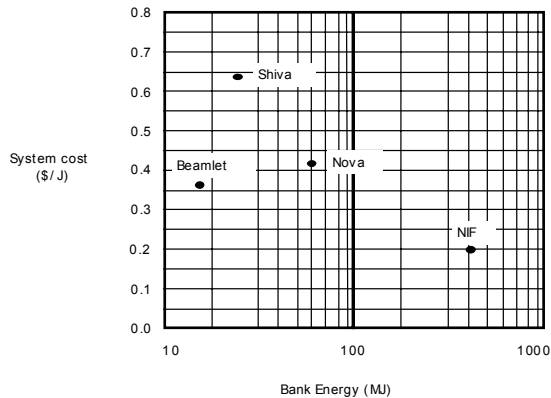

**Figure 2.** Per unit cost of stored energy for LLNL flashlamp drivers (in today’s dollars).

As shown in Table 3, components in the MESM are required to be both long-lived and reliable in order to achieve the required 30 year life for the facility. Experimental data indicate that these requirements are achievable, even for high voltage/high energy density components. As an example, energy storage capacitors must be capable of achieving a minimum of 20,000 shots while rigorous life-testing shows that 50,000 shots are consistently achievable.

**Table 3.** Lifetime requirements for major components in the PCS MESM.

Component	Required lifetime/no. shots	Validated life
Capacitors	20,000 shots	50,000 shots
Main switch	2000 shots (280 kC)	Rebuild at 2000 shots
Main Switch Trigger	20,000	100,000 shots

A simplified schematic of a MESM is depicted in Figure 3. Energy is stored in 20 – 24 capacitors with the module capacitance ranging from 6 to 7.2 mF. Capacitors employ metalized-film technology with self-healing capabilities to achieve required lifetime and reliability. These capacitors are charged by a pair of switching power supplies, capable of charging the bank to 24 kV in just over 1 minute. Each capacitor is equipped with and protected from the effects of internal faults by a potted, stainless steel damping element (nominally 9  $\mu$ H and 25 m $\Omega$ ). A damping element is capable of maintaining its mechanical integrity through a capacitor fault but must be replaced along with the shorted capacitor after the event.

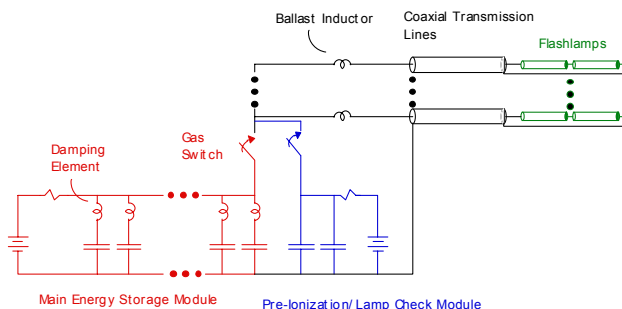

**Figure 3.** Simplified schematic of the PCS Main Energy Storage Module

The MESM main switch is a spark gap pressurized with clean, dry air. Offline experiments have shown that the spark gaps are capable of transferring ~280 kC and more than 2000 shots before the eroded graphite electrodes must be replaced. The pressure setpoint for a switch is determined by the amount of charge that has been conducted by the switch. Erosion and gas breakdown by-products are swept from the switch after a pulse by means of an air purge. Particulate matter is captured in a filter for future disposal. Ozone is swept into an exhaust system. The trigger for the main switch is provided by a pulse generator capable of delivering a pulse with a peak voltage of more than 110 kV to the spark gap trigger embedded in the wall of the switch. Figure 4 captures a discharge event in the main switch.

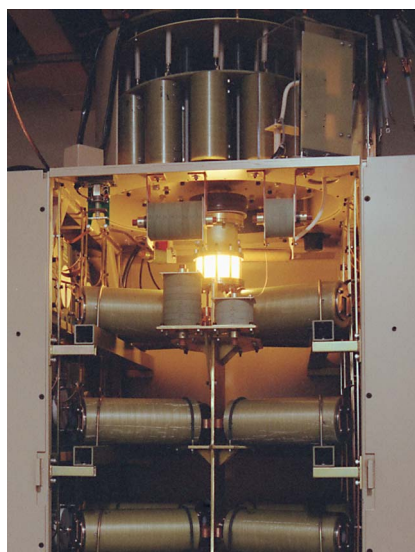
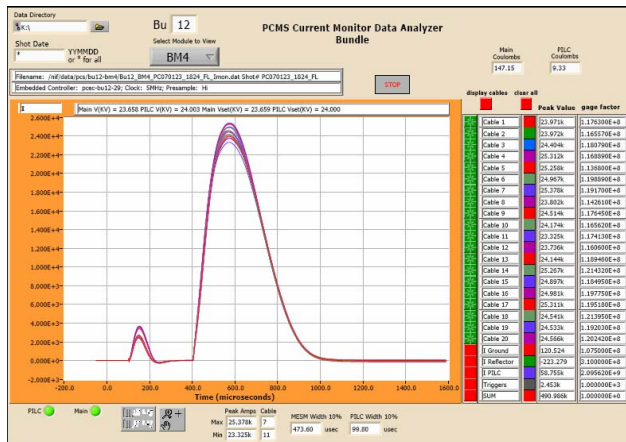

**Figure 4.** MESM discharge. Damping elements are visible below the switch. Ballast inductors are located above the switch in the “top hat.”

Wound from 6 mm diameter copper wire, the ballast inductors are potted and then contained in a fiberglass cylinder. The coils for a given module are chosen from four sub-types, each with a different inductance. The ballast inductors are used to set the pulsewidth of the output pulse and must compensate for varying cable

lengths between the module and flashlamps. Each module is connected to the flashlamp via 21 concentric neutral URD (underground residential distribution) cables, with 20 connecting directly to flashlamps and a single cable providing a well-defined, low-impedance path for reflector fault currents. (Employing URD instead of RG-220 saved over \$1M in cable costs. More than 150 km of URD were purchased and installed.) Cable lengths range from 20 to 57 meters, depending on the distance from the module to the flashlamps it drives. The current of each cable is monitored on each shot to provide necessary feedback on module performance and flashlamp health. While MESMs correspond to flashlamps within a given bundle, the output of a given module may drive flashlamps in both the main amplifier and power amplifier.

Unlike the pulsed power system in Nova, NIF's predecessor, the MESMs have an autonomous, self-contained pre-ionization/lamp check (PILC) system. A separate 26 kV power supply and a pair of energy storage capacitors provide the energy that is switched through a dedicated spark gap for initiating the ionization process in the flashlamps approximately 300  $\mu$ s before the main pulse. The pre-ionization pulse stores and delivers energy equivalent to  $\sim 5\%$  of that which is stored in the main bank. A lamp check pulse is applied after each main shot to verify that the flashlamps have survived the main discharge and are ready for the next shot. Erosion in the PILC spark gap is virtually non-existent so this switch operates at a constant pressure throughout its life. Output current for the pre-ionization and main discharge events are illustrated in Figure 5.



**Figure 5.** Pre-ionization and main discharge lamp currents, 1 module. Currents for 20 lamp pairs are superposed. View is that provided to system operator in the NIF Control Room.

## V. CONTROLS

The entire PCS system is operated from a single console by a single operator. A computer based control system handles virtually every aspect of the sequence of

events: an algorithm, aware of the status of the main switch and the charge is has conducted, issues commands that set the pressure in the gas chassis and, ultimately, the main switch; it issues commands that lead to the charging of the main bank and PILC bank and the charging of the spark gap triggers. The system is monitored for pre-fires at all times. Once the timing system has issued triggers for the PILC and main switches, another algorithm does post-shot waveform analysis and controls the lamp check shot as well as the purge cycles for the two spark gaps.

## VI. SAFETY

Personnel and equipment safety is of utmost importance. MESMs are designed to contain shrapnel generated during a fault. Pressure relief has been incorporated into the design as well. (Any shrapnel following the path of the gas will experience at least three energy-depleting caroms before embedding themselves in a block of soft pine.) Walls of the bays are encased in heavy plywood for additional protections. In addition, capacitor bays are swept prior to charging and remain unoccupied during “shots.”

Given the amount of energy stored in the modules and the potential for shock or electrocution, lock-out tag-out (LOTO) and “safing” procedures are strictly enforced and are driven by detailed procedures. Toolboxes are “shadowed” to indicate when hand tools are out of place.

## VII. PRODUCTION

Raytheon Technical Services has served as the system integrator for the vast majority of the PCS modules. As such, Raytheon incorporates various components from their sub-contractors, along with government furnished equipment purchased, tested and delivered by LLNL, into complete assemblies that are fully tested before they are shipped to LLNL.

A key element of this integration strategy is random selection of high power components for destructive and/or life testing. As an example, sample inductors and damping elements are routinely sectioned to verify uniformity in potting and winding. Capacitors are pulled from lots for life-testing (20 000 “shots”), while all capacitors experience 500 full-power charge/discharge cycles before being incorporated into a module.

## VIII. STATUS

As of January 2007, NIF has been operating three shifts per day. Two shifts are dedicated to “operations,” i.e., actual firing of the laser system and propagation of beams. A single shift is dedicated to installing, activating and maintaining equipment. From a PCS standpoint this single shift represents the time when modules are installed and activated, commissioning takes place and the period when problems encountered during operations are addressed. Module activation and commissioning are complex, multi-day processes that exercise all aspects of unit operation, ensuring that all requirements are met before the hardware is turned over to NIF Operations.

At this point in time, three of the four capacitor bays are filled to nominal capacity, with the commissioned modules being used to support shot operations. A fourth bay is being populated at an accelerated rate with the module fabricator/integrator, Raytheon Technical Services, producing and delivering an average of seven modules per month.

To date, PCS has achieved and maintained outstanding reliability, achieving greater than 95% availability for shots. Tens of thousands of modules (main, pre-ionization and lamp check) pulses have been accumulated as part of module system activation, commissioning and operations.

## IX. FUTURE WORK

Over the next few months, the mission of the power conditioning group will be to complete the installation, activation and commissioning of the remaining modules. Completion of module commissioning will shift the emphasis to the development and training of a sustaining maintenance and operations organization. Already, preparation of training documentation is being prepared in large volumes and operations workers are being trained to take on the varied tasks that will occupy them once the engineering team takes a less prominent role.

## X. CONCLUSION

The Power Conditioning System at the National Ignition Facility is on a path for completion of module production by the end of 2007 with final system commissioning to be finished in early 2008. The entire facility is scheduled to be completed in 2009 with 2010 bringing a campaign to achieve fusion using all 192 beams.

## XI. REFERENCES

[1] M. Newton, NIF Amplifier Power Conditioning System (PCS) Design Basis Document, LLNL Internal Document, June 2002.

[2] Mark A. Newton, et al., NIF Amplifier Power Conditioning System (PCS) Hazard Analysis and Safety Implementation Plan, LLNL Internal Document, UCRL-MA-150514, Oct. 1, 2002.

[3] M. Newton, et al., Main Amplifier Power Conditioning for the NIF, LLNL Internal Document, UCRL-LR-105821-99-1.