

# Development of Microbial Fuel Cell Prototypes for Examination of the Temporal and Spatial Response of Anodic Bacterial Communities in Marine Sediments

Y. Meriah Arias-Thode<sup>a</sup>, Ken Richter<sup>a</sup>, Adriane Wotawa-Bergen<sup>a</sup>, D. Bart Chadwick<sup>a</sup>, Jinjun Kan<sup>b</sup>, and Kenneth Neilson<sup>b</sup>

<sup>a</sup>Space and Naval Warfare Systems Center, Pacific; 53560 Hull Street; San Diego, CA 921252-5001; [meriah.ariatsthode@navy.mil](mailto:meriah.ariatsthode@navy.mil)

<sup>b</sup>Department of Earth Sciences, University of Southern California, Los Angeles, CA 90089, USA

**Abstract-** Many bacteria can convert chemical energy to electrical energy: they oxidize diverse organic substrates, transfer electrons to anodic electrodes and thus generate electricity in microbial fuel cells (MFCs). In the marine environment, microbial fuel cells, termed either sediment or benthic microbial fuel cells, have been developed to generate power via anodic bacteria in the ocean sediment. Power is dependent upon enriched anodic bacteria that transport their electrons onto the anode. The marine deployed MFC systems can provide renewable, harvested power to trickle charge batteries or other storage devices. Through power management systems these storage devices can power traditional electronic loads of interest. The systems have the promise to allow for long term deployment of in-water sensor and communications systems, providing decreased maintenance and increased operational capabilities.

In this study, two sediment microbial fuel cells were deployed in the San Diego Bay over a 60 day time period. The fuel cells deployed in the field for the purpose of sampling bacteria on and adjacent to graphite sheet anodes buried in marine sediment. The anodes were connected electrically via a potentiostat to a carbon fiber brush cathode, which floated freely in the water column. Succession and spatial response of anodic bacterial population structures were monitored. The anodes were buried in the marine sediment containing an organic carbon content of ~ 1.4% TOC. Sediment cores (1 cm x 5 cm) were extracted on each side of two parallel anode electrodes, in the space between the electrodes (~2.5 cm away from anode), and 15 cm away from the anode. Sediment cores were individually homogenized and 0.5 g per sample of the sediment was used to determine most probable number (MPN) of iron-reducing bacteria; another 0.5 g per sample of sediment was used for molecular biology analysis of DGGE (denaturing gradient gel electrophoresis) and cloning (data analysis in process; to be presented at conference). Results demonstrated that power increased linearly over a two week period; the delay could be due to bacterial growth and changing metabolism to use the anode for a terminal electron acceptor. After 15 days, numbers of iron-reducing bacteria were higher by two orders of magnitude next to the anode versus 15 cm away from the anode. When the cathode became anoxic, current production decreased accordingly; demonstrating that anodic bacteria could have been dependent upon the microbial fuel cell potential and responsible for the power produced. DGGE analysis of the bacteria in the iron-reducing medium demonstrated unique results by Day 60. Relative to the control, observed responses were populations of bacteria that over time became more similar to each other next to the anode, and also, in the space between the two anodes (5 cm)-

but were very different 15 cm away from the anode. This result insinuates that bacterial groups not only respond to anodic electrochemistry, but, may be using cell to cell contact to transfer electrons or, may be transferring electrons to quite further distance (cm) via electrically conductive appendages (Reguera, 2005; Gorby, 2006; Nielsen, et al, 2010). This is the first bacterial study investigating the potentially cm scale electron transport of sediment microbial fuel cells in the field environment. These data will be presented at conference.

## II. INTRODUCTION

There is currently a strong thrust for alternative power sources. The US Navy is interested in a marine sediment microbial fuel cell that has the potential to provide residual power to recharge batteries and to provide a decreased need for maintenance of in-water sensors and other navigation devices (Office of Naval Research, 2010). The usage of a microbial fuel cell for generation of power has been investigated since 1911 (Potter, 1911) and the system concept was demonstrated in 1974 (Karube, 1974).

It has been found that bacteria are responsible for providing power to a MFC via establishment of a redox potential and via the transfer of electrons to an anode. Bacteria from marine environments have been evaluated and determined to utilize graphite material in anodes as terminal electron acceptors (Reimers, et al, 2001; Bond and Lovley, 2002; Tender, et al, 2002; Lowy, et al, 2006; Reimers, 2006; Reimers, et al, 2007).

At the Space and Naval Warfare Systems Center- Pacific, microbial fuel cell prototypes have been tested and evaluated in a field environment to determine their potential to power devices such as acoustic arrays (Richter, et al, 2010). The purpose of the work discussed in this paper is to evaluate the microbial biofilm on the MFC anode, as well as the bacteria located adjacent to, and between two anodes, so that sediment MFCs can be designed to optimize microbial interactions. Two MFC prototypes were developed specifically for the purpose of temporal and spatial sediment core sampling of the microbial community, to test the microbial response in the field environment.

## III. APPROACH

The approach was to make sediment microbial fuel cells (MFCs) that are durable and able to withstand placement of the MFCs into marine sediment in an intertidal area. Lessons

This work was supported by the Office of Naval Research (ONR), an ONR Internal Laboratory Innovative Research grant, and an ONR, Naval Innovative Science and Engineering grant.

# Report Documentation Page

Form Approved  
OMB No. 0704-0188

Public reporting burden for the collection of information is estimated to average 1 hour per response, including the time for reviewing instructions, searching existing data sources, gathering and maintaining the data needed, and completing and reviewing the collection of information. Send comments regarding this burden estimate or any other aspect of this collection of information, including suggestions for reducing this burden, to Washington Headquarters Services, Directorate for Information Operations and Reports, 1215 Jefferson Davis Highway, Suite 1204, Arlington VA 22202-4302. Respondents should be aware that notwithstanding any other provision of law, no person shall be subject to a penalty for failing to comply with a collection of information if it does not display a currently valid OMB control number.

1. REPORT DATE <b>2012</b>		2. REPORT TYPE		3. DATES COVERED <b>00-00-2012 to 00-00-2012</b>	
4. TITLE AND SUBTITLE <b>Development of Microbial Fuel Cell Prototypes for Examination of the Temporal and Spatial Response of Anodic Bacterial Communities in Marine Sediments</b>				5a. CONTRACT NUMBER	
				5b. GRANT NUMBER	
				5c. PROGRAM ELEMENT NUMBER	
6. AUTHOR(S)				5d. PROJECT NUMBER	
				5e. TASK NUMBER	
				5f. WORK UNIT NUMBER	
7. PERFORMING ORGANIZATION NAME(S) AND ADDRESS(ES) <b>Space and Naval Warfare Systems Center,,Pacific; 53560 Hull Street,,San Diego,CA,921252</b>				8. PERFORMING ORGANIZATION REPORT NUMBER	
9. SPONSORING/MONITORING AGENCY NAME(S) AND ADDRESS(ES)				10. SPONSOR/MONITOR'S ACRONYM(S)	
				11. SPONSOR/MONITOR'S REPORT NUMBER(S)	
12. DISTRIBUTION/AVAILABILITY STATEMENT <b>Approved for public release; distribution unlimited</b>					
13. SUPPLEMENTARY NOTES					
14. ABSTRACT					
15. SUBJECT TERMS					
16. SECURITY CLASSIFICATION OF:			17. LIMITATION OF ABSTRACT <b>Same as Report (SAR)</b>	18. NUMBER OF PAGES <b>6</b>	19a. NAME OF RESPONSIBLE PERSON
a. REPORT <b>unclassified</b>	b. ABSTRACT <b>unclassified</b>	c. THIS PAGE <b>unclassified</b>			

learned from deploying MFCs developed by Oregon State University (OSU), Naval Research Laboratory (NRL), and Space and Naval Warfare (SSC)- Pacific (Fig. 1) led to the designs developed for this study (Wotawa-Bergen, 2010). The two prototypes developed for this study were designed to have a small foot-print, be rapidly field deployable, and have the capacity to evaluate microbial communities near and on the anode. The primary focus of the study was to evaluate the relationship between the microbial activity and the power generation, to this end the systems were designed to be anode limited.

Both architectures had identical cathodes, load electronics, and data acquisition devices. The sole difference between the two systems was the anode architecture; one architecture is hence referenced as the ‘Eel’ and the other the ‘Octopus’. Although the anode architecture differed in configuration both used the same compressed graphite material as the “Grid” design (Fig. 1) developed by Tender, NRL and SSC-Pacific (Richter, 2010; Wotawa-Bergen, et al, 2010).

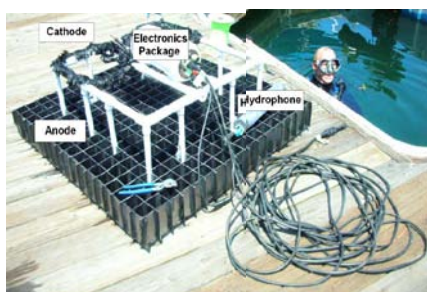

Figure 1. Modified sediment-MFC developed by SSC Pacific and the Naval Research Laboratory (Wotawa-Bergen, 2010).

Both MFC architectures were deployed in the San Diego Bay at the Marine Corps Recruitment Depot where OSU, NRL, and SSC-Pacific microbial fuel cells have been previously deployed and tested (Wotawa-Bergen, et al, 2010). The two architectures (Fig. 2 and Fig 3) were deployed for a 60 day period, from March 1 2010 to April 30 2010. Samples were taken at days 0, 2, 5, 28, and 60 and analyzed for iron-reducing bacterial growth. For the MFC with the “Eel” architecture, sediment cores were taken near, between, and 15 cm away from the anodes. The MFC with the ‘Octopus’ anode architecture was constructed to allow sacrificial removal of anode material for direct swabbing of the anode.

Iron- reducing bacterial counts were made in culture dependent microbiological medium (see microbiology section below). A culture independent technique, denaturing gradient gel electrophoresis and cloning of bacterial cells adjacent to and between anodes was also performed. Data are in process for the culture independent techniques and will be presented at conference.

*Microbiology.* The cores used to evaluate sedimentary bacteria were 25 mL pipets (Falcon, sterile, individually wrapped pipets, Product # 356525) that had the tips removed with a hot knife. Core size was approximately (1 cm x 5 cm.). Cores were taken adjacent to the anode. The cores were stored in a refrigerator and transferred within 1 day into a nitrogen

plus 5% hydrogen gas anaerobic chamber, homogenized, and 0.5 g of sediment was distributed into a 1X phosphate buffered saline (PBS) in a 1:10 dilution (4.5 mL PBS). From the initial 1:10 dilution of PBS, a secondary 1:10 dilution was made in a 10 mL conical in a Fe(III)-citrate bacterial medium. Further dilutions were made into 24 multi-well plates (BD Falcon, Product # 353847) and spanned to  $1 \times 10^8$ . The basal medium was Widdel’s (Widdel and Bak, 1992) anaerobic marine medium with lactate (20 mM) as the electron donor; and Fe(III)- citrate (10 mM) as the terminal electron acceptors for iron- reducing bacteria. Differences from the Widdel medium (Widdel and Bak, 1992) are 0.5g yeast extract (versus 10 g) and no reductant ( $\text{Na}_2\text{S}$ ) was used.

#### IV. MFC CONSTRUCTION

The prototypes were designed based on previous iterations by Peter Kauffman from Northwest Metasystems Inc, that incorporated design improvements and optimizations (Wotawa- Bergen, 2010). Both MFC systems deployed were the same except for their anode geometry. Similar to the Grid architecture developed in previous research the anode was made of compressed graphite sheets. For this study multiple anode sheets were connected electrically using underwater cabling to a node which was potted. The cathode consisted of approximately 10 cm long carbon fibers attached to titanium wire which was supported by a hard plastic rod. The anode and cathode were connected to an underwater deployable electronics package via underwater connectors (Teledyne Impulse, San Diego, CA). The electronics package consisted of a potentiostat set to approximately 0.4v which was developed by Peter Kauffman. The MFC current generation and potentiostat voltage were recorded by a DC voltage data acquisition device (Madgetech, New Hampshire).

The ‘Eel’ anode architecture was comprised of two graphite anodes (30.5 cm x 11.5 cm x 0.4 cm) in parallel, 5 cm apart. The ‘Eel’ prototype was design for sediment core samples to be taken adjacent to, between, and 30 cm away from the anode material. A redwood block structure (45cm x 15 cm x 7 cm) was built to hold the two plates 5 cm apart. The structure had ten sets of three holes 1 cm large along the length of the anode electrodes. One hole was located directly next to the electrode 1, the second was located directly next to electrode 2, and the third was half way between the two electrodes (approximately 2.5 cm); called the ‘spacer’ region. For each day of sampling, samples were taken at a different set of holes for electrode 1, electrode 2, the spacer, and 15 cm away from the redwood structure. The anode electrodes stuck out perpendicular to the structure and the structure and anode were buried into the sediment. The top of the structure was just flush with the sediment-water interface. A reinforcing bar was attached to the wood structure and anchored the anode and wood into the sediment.

The ‘Octopus’ prototype was made to take sacrificial samples of the microbial biofilm on the anode surface; anodic bacteria. The ‘Octopus’ anode design was comprised of 9 graphite sheet electrodes (each 7 cm x 7 cm) buried into the sediment (Fig. 2B and 3C). During sample days (days 2, 5, 28,

and 60) one of the electrodes from the ‘Octopus’ design was sacrificed and the electrical connection was cut underwater. The cut cable was immediately placed into a balloon containing silicon to protect the copper wire and connected electronics from sea water corrosion. The sacrificed anode electrode surface was then swabbed into the modified Widdel’s anaerobic medium for iron-reducing bacteria in the anaerobic chamber to sample the bio-film.

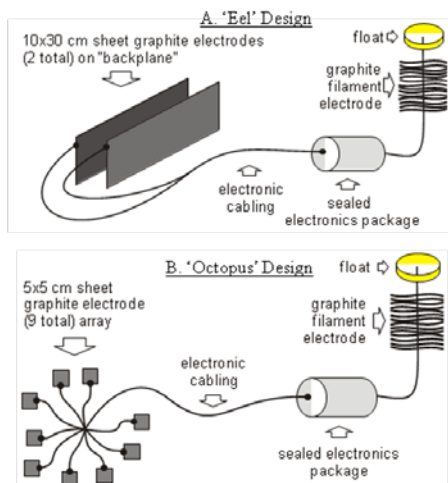

Figure 2. Schematic of the ‘Eel’ and ‘Octopus’ MFC system designed to take bacterial samples. Fig. 2A. ‘Eel’ design, 10x30 cm sheet graphite electrodes (2 total) on redwood backplane attached to electronic cabling. Fig. 2B. ‘Octopus’ design, 5x5 cm attached to electronic cabling. In both scenarios the sealed electronics package lies directly on the ocean sediment. The graphite filament electrode is suspended in the marine water column to a float.

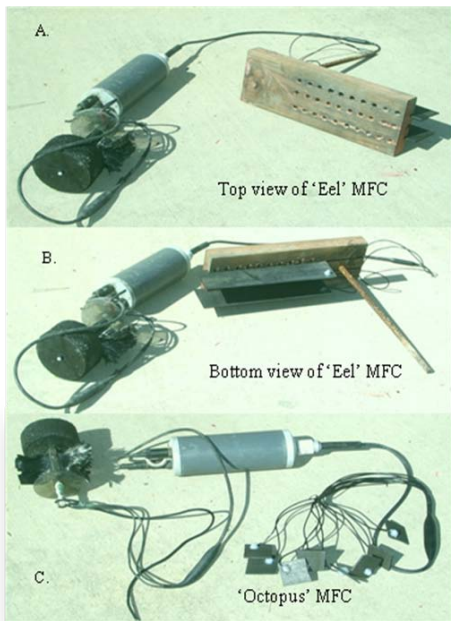

Figure 3. Microbial fuel cells designed specifically for bacterial sampling over time.; Fig 3A and 3B are “Eel” MFC; top and bottom viewpoints; Fig. 3C is the ‘Octopus’ MFC. Fig. 3A. Top view of the redwood board with holes drilled to enable sediment core sampling to occur adjacent to (outside holes), and ~2 cm away from the two anodes (center hole). Fig. 3B. Bottom view to visualize the two anodes placed 5.5 cm apart; placed for sampling in the space between the two anodes. Fig. 3C. ‘Octopus’ MFC’; 9 small 7x7 cm<sup>2</sup> sacrificial anodes attached to an underwater deployable electronics package.

## V. RESULTS & DISCUSSION

### A. BACTERIA RESPONSIBLE FOR POWER

In previous laboratory and field testing of power generated by MFCs, several observations were made as to the generation of power due to bacterial processes (Reimers, et al, 2001; Bond and Lovley, 2002; He, 2009; Kan, 2010; Tender, et al, 2002; Lowy, et al, 2006; Reimers, 2006). An in-house laboratory experiment to determine the kinetics and sensitivity of the fuel cells comprised of 3 small MFCs designed to be anode limited (anode dimensions). The MFCs (red, black, and blue lines) were placed in a 30 cm by 40 cm plastic dishpan containing sandy, low total organic carbon, 0.31% TOC (Richter, unpublished), sediments (Fig.4). The experiment started 10 days prior to the data graphed (Fig. 4). Initially the power increased to 4 mW/ m<sup>2</sup>. However, what is observed in the graph is power decay to less than 2 mW/ m<sup>2</sup> (Fig. 4A) post ~ 10 days. The power increased upon stirring of the sandy sediment (Fig. 4A). To demonstrate that the power was dependent on bacteria and show they were responding to a carbon source, the sediment was microwaved and an accompanying power die-off was observed (Fig. 4B). Microwaving of sediment will not kill off all bacteria (as they can be protected by remaining within sediment clumps). Approximately 3 grams of chitin (from crab shells, practical grade, coarse flakes, Sigma Aldrich, Product #C9213, CAS#1398-61-4), were then added over the sediment and power later increased by an order of magnitude (Fig. 4C) relative to only stirring (Fig. 4B). Serendipitously, one of the MFCs leaked copper (black line) due to electrical contact corrosion, and power decreased sharply. Copper is toxic to bacteria (Trevors and Cotter, 1990); hence, bacteria were not able to produce power. Additionally, examining the data from Fig. 6, which is a separate experiment, there is a ~2 week linear increase in power; the delay could be due to bacterial growth and changing metabolism to use the anode for a terminal electron acceptor. These data provides further evidence that bacteria are responsible for power production of microbial fuel cells operating in a marine environment.

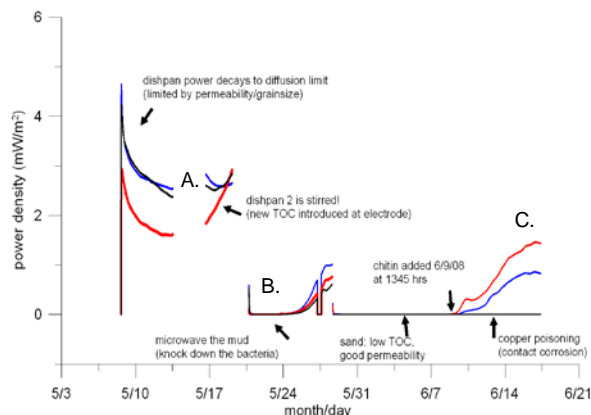

Figure 4. Replicate laboratory power measurements of power output in sediment with 0.31% total organic carbon (9% silts and clays). Fig. 4A. post stirring to introduce new TOC; B. post microwaving to demonstrate power provided by microbes, C. upon addition of chitin to sand.

## V. RESULTS & DISCUSSION

### B. OXYGEN HAS EFFECT ON POWER

The grid-like MFC, designed by NRL and SSC, Pacific (Fig. 1) to overcome anode breakages, anode burial challenges, and decrease organism disturbances was evaluated in a field environment (2% total organic carbon) to determine the effect; if any, of oxygen, temperature, and tidal height on the MFC power performance. Our studies have demonstrated that limiting oxygen to the cathode does not inhibit the MFC in laboratory and field settings (unpublished data). The MFC was deployed in approximately 5 meters of water in a tidal environment. In analyzing this data (Fig. 5), there does not seem to be any direct correlation on tidal height (black line) or temperature (dark blue line) to current production (red line). However, there does appear to be a correlation of a slight uptick in power with increased oxygen concentration (light blue line).

The 'Eel' and 'Octopus' MFC prototypes were deployed in a field environment (1.4% total organic carbon) to evaluate power production and determine bacterial communities adjacent to and on the surface of the MFC anodes. The power produced for the 'Eel' MFC are shown in Figure 6. The 'Octopus' power production data are not shown as the underwater deployable electronics package became flooded and didn't function. The 'Eel' MFC was deployed in an intertidal area during Spring tides. Therefore, during very low tides (-1.0 m to -0.9 m 31Mar to 02Apr 2010), the floating cathode came into contact with the anoxic sediment and became partially buried. Upon observance of this fact, the graphite filaments of the cathode were 'shaken' to remove the excess sediment and the cathode became free-floating. Power increased immediately. Approximately one month later (27Apr to 01May 2011), a similar situation occurred as again, the cathode became buried in the anoxic sediment during a very low tidal event (-1.3m to -1.0m low tide). Both of these events demonstrate that the power produced by the MFC is dependent on the cathode remaining in an oxygenated water column. Naturally occurring oxygen dips in the water column have little effect on the MFC power; however, the cathode should be in a mostly oxygenated water column to generate viable power.

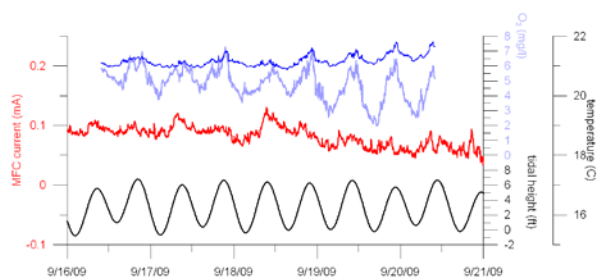

Figure 5. Dissolved oxygen and anode current near the bottom at in sediment with 2% total organic carbon (30% silts and clays). Power is shown relative to tidal height, oxygen (mg/L), and temperature (°C).

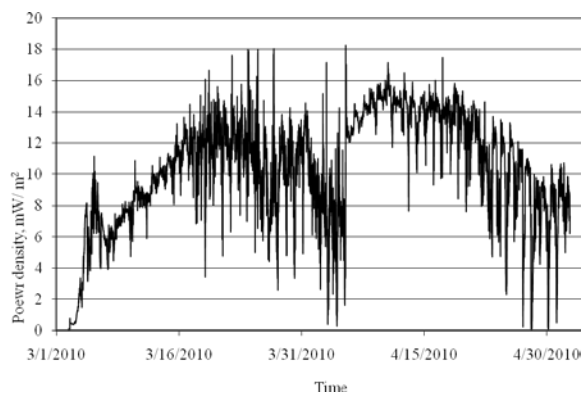

Figure 6. Microbial fuel cell (in 2% TOC marine sediment) power produced in the 'Eel' MFC prototype over a 60 day period. Power production took ~ 2 weeks period to obtain maximum power. Notice the dips that occur at ~ Day 30-35 and Day 55-60.

## V. RESULTS & DISCUSSION

### C. IRON- REDUCING BACTERIAL CORRELATION TO POWER

Several laboratory studies working with pure cultures and some mixed cultures have demonstrated that dissimilatory metal reducing bacteria (Gorby, 2006; Lovley, 2006), many of which are iron- reducing bacteria (FeRB), are the most likely group of bacteria that contribute electrons to electron acceptors that cannot enter the cells (Lovley et al., 1987, 1996; Myers and Nealson, 1988). Therefore, it is predicted that these same groups of bacteria are likely to transfer electrons externally to anodes and therefore, produce power in anaerobic sediments. Sulfate- reducing bacteria (SRB) are also considered to be very important contributors to the geo-chemical processes in the sediment. In more anoxic environments, the SRB usually are found in greater concentrations versus FeRB. However, dependent on the carbon source, electron donors, and electron acceptors available, the bacterial community dynamics will usually change in a predictable way. To date, FeRB appear to be the most prevalent and important for power production.

Furthermore, there have been findings that are highly suggestive of bacterial cell-to-cell movement of electrons in sediments. In laboratory settings, there was an increase in power due to a formation of bacterial nanowires demonstrated by an FeRB, *Shewanella oneidensis* strain MR-1 in response to electron- acceptor limitation in a laboratory MFC (Gorby, et al, 2006). Therefore, we suspect that electrons may also be transferred via nanowires (or, cell to cell) by bacteria on the surface of a MFC anode and adjacent to a MFC as these processes have been observed before in other bacterial cultures (Nielson, 2010); but there is not data to date for this experiment.

Data characterizing the FeRB from the 'Eel' MFC deployment are available in Figure 7. These data represent culturable FeRB bacteria that were able to thrive using Fe(III)-citrate as a terminal electron acceptor and lactate as an electron donor. At day zero, the numbers of FeRB are not statically different in the control (15 cm away from the anode), adjacent to the anode, and approximately 2 cm away, between the two

anodes (spacer). When evaluated over time (0-28 days), the number of FeRB in the control samples were very similar ( $\sim 1 \times 10^{4.5}$ ). However, in evaluating both the culturable FeRB adjacent to the anode and in the spacer region, there is a significant increase of bacterial numbers; almost a doubling at the 28 day period observed. Culturable SRB were not counted in this experiment. However, future endeavors will attempt to characterize numbers of SRB on and adjacent to field deployment of MFCs.

The ‘Octopus’ MFC anodes were deployed to characterize bacteria on a MFC anode and determine if they were similar to the bacteria characterized adjacent to and between the anodes in the ‘Eel’ MFC. Unfortunately, there was poor power data due to electronics package flooding for the ‘Octopus’ system, and the bacterial study at the anode does not correlate to the MFC power generation.

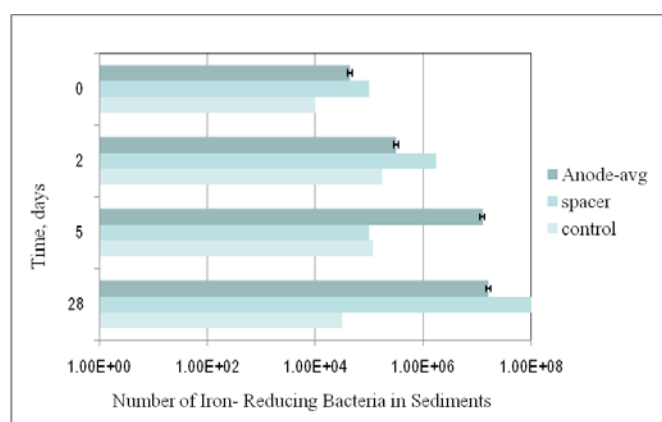

Figure 7. Most probable number of iron-reducing bacteria adjacent to, and in between anodes in high total organic carbon environment. The control was located  $\sim 15$  cm away from the anodes.

## VI. CONCLUSIONS AND FUTURE WORK

In conclusion, this research demonstrates two prototype MFC systems that were developed to facilitate examination of the temporal and spatial response of anodic bacteria in marine microbial fuel cells. The ‘Eel’ MFC prototype design functioned well as a means to examine sediment cores (for bacteria in this case) adjacent to and  $\sim 2.5$  cm away from two anodes. The ‘Octopus’ prototype design presumably would have functioned well to measure microbial bio-films on MFC anodes in a temporal fashion. Further work is necessary to determine the capacity of the ‘Octopus’ design, with sacrificial anodes, to function as a means to examine anodic bacteria.

## ACKNOWLEDGMENT

Y.M.A.T. thanks Jewel Powe for her help in media and sample preparation.

## REFERENCES

[1] D.R. Bond, D.E. Holmes, L.M. Tender, and D.R. Lovley, “Electrode-reducing microorganisms that harvest energy from marine sediments,” *Science* 2002, vol. 295, pp. 483–485, 2002.

[2] Y.A. Gorby, S. Yanina, J.S. McLean, K.M. Rosso, D. Moyles, A. Dohnalkova, and et al, “Electrically conductive bacterial nanowires

produced by *Shewanella oneidensis* strain MR-1 and other microorganisms,” *Proc. Natl. Acad. Sci. U.S.A.*, vol.103, pp. 11358–11363, 2006.

[3] Z. He, J. Kan, F. Mansfeld, L.T. Angenent, and K.H. Nealon, “Self-sustained phototrophic microbial fuel cells based on the synergistic cooperation between photosynthetic microorganisms and heterotrophic bacteria,” *ES&T*, vol. 43, pp. 1648-1654, February 2009.

[4] J. Kan, L. Hsu, A.C.M. Cheung, M. Pirbazari, and K.H. Nealon, “Current production by bacterial communities in microbial fuel cells enriched from wastewater sludge with different electron donors,” *Environ. Sci. Technol.*, vol. 45, pp.1139-1146, 2011.

[5] I. Karube, T. Matasunga, S. Suzuki and S. Tsuru, “Biochemical cells utilizing immobilized cells of *Clostridium butyricum*,” *Biotechnology and Bioengineering*, vol.19, pp. 1727–1733, 1977.

[6] B.E. Logan, *Microbial Fuel Cells*. New Jersey, USA: John Wiley and Sons, Inc., 2007.

[7] D. R. Lovley, J.F. Stolz, G.L. Nord, E.J.P. Phillips, Anaerobic production of magnetite by a dissimilatory iron-reducing microorganism,” *Nature* vol. 330, pp. 252–254,1987.

[8] D.R. Lovley, J.D. Coates, E.L. Blunt-Harris, E.J.P. Phillips, J.C. Woodward, “Humic substances as electron acceptors for microbial respiration,” *Nature* vol.382, pp. 445–448,1996.

[9] D. R. Lovley, “Microbial Energizers: Fuel cells that keep on going,” *Microbe*, vol. 1, pp. 323-329, 2005.

[10] D.A. Lowya, L.M. Tender, J.G Zeikus, D.H. Park, and D.R. Lovley, “Harvesting energy from the marine sediment–water interface II- Kinetic activity of anode materials,” *Biosensors and Bioelectronics*, vol. 21, pp 2058-2063, 2006.

[11] C.R. Myers, K.H. Nealon, “Bacterial manganese reduction and growth with manganese oxide as the sole electron-acceptor,” *Science*, vol. 240, pp.1319–1321, 1988.

[12] L. P. Nielsen, N. Risgaard-Petersen, H. Fossing, P.B. Christensen, and M. Sayama, “Electric currents couple spatially separated biogeochemical processes in marine sediment,” *Nature*, vol.463, April 2010.

[13] M.C. Potter, “Electrical effects accompanying the decomposition of organic compounds,” *Royal Society (Formerly Proceedings of the Royal Society) B*, vol. 84, pp. 260-276, 1911.

[14] Office of Naval Research, “Microbial Fuel Cell: a New Source of Green Energy,” <http://www.onr.navy.mil/Media-Center/Press-Releases/2010/Microbial-Fuel-Cell.aspx>, Press Release, April 16, 2010.

[15] C. E. Reimers, L.M. Tender, S. Fertig, and W. Wang, “Harvesting energy from the marine sediment-water interface,” *Environ.Sci. Technol.*, vol. 35, pp.192-195, 2001.

[16] C.E. Reimers, P. Girguis, H.A. Stecher, L.M. Tender, and N. Ryckelynck, P. Whaling, “Microbial fuel cell energy from an ocean cold seep,” *Geobiology*, vol. 4, pp. 123-136, 2006.

[17] C.E. Reimers, A. Hilmar, H.A. Stecher III, J.C. Westall, Y. Alleau, K.A. Howell, L. Soule, H.K. White, and P.R. Girguis, “Substrate Degradation Kinetics, Microbial Diversity, and Current Efficiency of Microbial Fuel Cells Supplied with Marine Plankton,” *AEM*, vol. 73, pp.7029-7040, 2007.

[18] G. Reguera, G. et al., “Extracellular electron transfer via microbial nanowires”. *Nature*, vol. 435, pp. 1098–1101, 2005.

[19] K. Richter, D.B. Chadwick, and L.M. Tender, “Microbial fuel cell design sufficient to power a hydrophone over a several month period,” 217<sup>th</sup> *Electrochemical Society Meeting*, Vancouver BC, April 24<sup>th</sup> - April 29<sup>th</sup> 2010.

[20] L.M. Tender, C.E. Reimers, H.A. Stecher, D.E. Holmes, D.R. Bond, D.A. Lowy, K. Pilobello, S.J. Fertig, and D.R. Lovley, “Harnessing microbially generated power on the seafloor,” *Nat.Biotechnol.*, vol. 20, pp. 821-825, 2002.

[21] J.T. Trevors and C.M. Cotter, “Copper toxicity and uptake in microorganisms,” *J. of Industrial Microbiology*, Vol 6, pp. 77-84, 1990.

[22] A.Q. Wotawa-Bergen, D.B. Chadwick, K.E. Richter, L.M. Tender, and C.E. Reimers, “Operational Testing of Sediment-based Microbial Fuel Cells in the San Diego Bay,” *Oceans '10 MTS/IEEE Seattle*, Sept 20-23, 2010, Seattle, WA.

[23] F. Widdel, and F. Bak. “Gram- negative mesophilic sulfate-reducing bacteria”. In: *The Prokaryotes*, vol. 4. pp. 3352-3378. Ballows, A., H.G. Truper, M. Dworkin, W. Harder, and K.H. Shleifer, Eds., Springer, Berlin, New York, 1992