

Planar Decision Diagrams for Multiple-Valued Functions*

TSUTOMU SASAO^a and JON T. BUTLER^b

^a*Department of Computer Science and Electronics, Kyushu Institute of Technology, Iizuka 820, Japan*

^b*Department of Electrical and Computer Engineering, Naval Postgraduate School, Monterey, CA 93943-5121*

Recommended for publication by Dan Simovici

(Received 15 October 1995)

In VLSI, crossings of interconnect occupy space and cause delay. Therefore, there is significant benefit to planar circuits. We propose the use of planar multiple-valued decision diagrams to produce planar multiple-valued circuits. Specifically, we show conditions on 1) threshold functions, 2) symmetric functions, and 3) monotone increasing functions that produce planar diagrams. Our results apply to binary functions, as well. For example, we show that all two-valued monotone increasing threshold functions of up to five variables have planar ordered binary decision diagrams.

Keywords: Ordered binary decision diagram (OBDD); ordered multiple-valued decision diagram (OMDD); computer-aided design; threshold function; symmetric function; dual function

1. INTRODUCTION

The existence of integrated circuits with more than one million gates has made imperative the efficient design of large logic functions. An important problem, therefore, is to represent large logic functions. Truth tables are inefficient; all functions on n variables require a table of size $O(2^n)$. Algebraic expressions are better; for example, the sum-

*A preliminary version of this paper has appeared in the IEEE Proceedings of the 25th International Symposium on Multiple-Valued Logic.

Report Documentation Page

Form Approved
OMB No. 0704-0188

Public reporting burden for the collection of information is estimated to average 1 hour per response, including the time for reviewing instructions, searching existing data sources, gathering and maintaining the data needed, and completing and reviewing the collection of information. Send comments regarding this burden estimate or any other aspect of this collection of information, including suggestions for reducing this burden, to Washington Headquarters Services, Directorate for Information Operations and Reports, 1215 Jefferson Davis Highway, Suite 1204, Arlington VA 22202-4302. Respondents should be aware that notwithstanding any other provision of law, no person shall be subject to a penalty for failing to comply with a collection of information if it does not display a currently valid OMB control number.

1. REPORT DATE OCT 1995		2. REPORT TYPE		3. DATES COVERED	
4. TITLE AND SUBTITLE Planar Decision Diagrams for Multiple-Valued Functions				5a. CONTRACT NUMBER	
				5b. GRANT NUMBER	
				5c. PROGRAM ELEMENT NUMBER	
6. AUTHOR(S)				5d. PROJECT NUMBER	
				5e. TASK NUMBER	
				5f. WORK UNIT NUMBER	
7. PERFORMING ORGANIZATION NAME(S) AND ADDRESS(ES) Naval Postgraduate School, Department of Electrical and Computer Engineering, Monterey, CA, 93943				8. PERFORMING ORGANIZATION REPORT NUMBER	
9. SPONSORING/MONITORING AGENCY NAME(S) AND ADDRESS(ES)				10. SPONSOR/MONITOR'S ACRONYM(S)	
				11. SPONSOR/MONITOR'S REPORT NUMBER(S)	
12. DISTRIBUTION/AVAILABILITY STATEMENT Approved for public release; distribution unlimited.					
13. SUPPLEMENTARY NOTES					
14. ABSTRACT					
15. SUBJECT TERMS					
16. SECURITY CLASSIFICATION OF:			17. LIMITATION OF ABSTRACT	18. NUMBER OF PAGES 26	19a. NAME OF RESPONSIBLE PERSON
a. REPORT unclassified	b. ABSTRACT unclassified	c. THIS PAGE unclassified			

of-products expression (SOP) for $x_1 \vee x_2 \vee \cdots \vee x_n$ has size $O(n)$. However, to represent $x_1 \otimes x_2 \otimes \cdots \otimes x_n$ requires an SOP of size $O(2^n)$.

During the past decade, there has been considerable interest in the ordered binary decision diagram (OBDD), a topic that has its origins in the 1960's and 1970's [1]. In an OBDD, nodes represent functions and edges represent assignments of values to variables. As with SOP's, the complexity of OBDD's varies. Widespread use of OBDD's in commercially available CAD packages is evidence of the compactness of this representation.

In this paper, we consider the ordered multiple-valued decision diagram (OMDD) of a *multiple-valued function* $f: R^n \rightarrow R$, where $R = \{0, 1, \dots, r-1\}$. The history of OMDD's is recent [4, 6]. For such functions, both the function and the variables take on values from R . We denote functions with $r=2$ as *switching functions*.

An OMDD of a function $f(x_1, x_2, \dots, x_n)$ is a directed graph that has a root node (i.e., no incoming edges) which represents f . From this node, there are outgoing edges labeled $0, 1, \dots, r-1$ directed to nodes that represent $f(0, x_2, \dots, x_n)$, $f(1, x_2, \dots, x_n)$, ..., and $f(r-1, x_2, \dots, x_n)$, respectively. For each of these nodes, there are r outgoing edges, etc., that go to nodes that have r outgoing edges, etc. A terminal node is a node with no outgoing edges. It is labeled by $0, 1, \dots$, or $r-1$, and corresponds to a logic value of the function. To achieve a compact representation, we require

- *merging rule*—if two nodes η_1 and η_2 represent the same function, then η_2 and its subtree are removed and all edges going to η_2 now go to η_1 .
- *elimination rule*—if a node η in which all descendents are the same node η_1 , then η is eliminated and all incoming edges to η go to η_1 .

Figure 1(a) shows an OBDD for $f = x_1 x_2 \vee x_3 x_4$. As is usual, arrows are omitted; edges are assumed to be directed down. Note that no edges cross in this OBDD. It is interesting that interchanging x_2 and x_3 yields an OBDD for this same function in which two pairs of edges cross. The OBDD corresponding to this ordering is shown in Figure 1(b).

DEFINITION 1 An OMDD or OBDD in which the merging and elimination rules have been applied to the greatest extent possible is a reduced OMDD or OBDD, respectively. These are denoted as ROMDD or ROBDD, respectively.

Bryant [2] has shown that, for any given ordering of variables, the OBDD is unique. Therefore, regardless of what order the merging and elimination rule and applied, the final OBDD is the same.

Example 1 Figure 1 shows two ROBDD's of the function $f = x_1x_2 \vee x_3x_4$ for different orderings of the variables. Note that the number of nodes is different for the two orderings.

In our analysis of planar OMDD's, we adopt the following restriction.

RESTRICTION 1

1. All edges are straight and emerge down from the root node;
2. All edges emerging from a node are labeled $0, 1, \dots, r - 1$ from left to right;
3. The leaf nodes (representing constant functions) are labeled $0, 1, \dots, r - 1$ from left to right.

With this restriction, we have

DEFINITION 2 An OMDD is planar if it can be drawn without crossings.

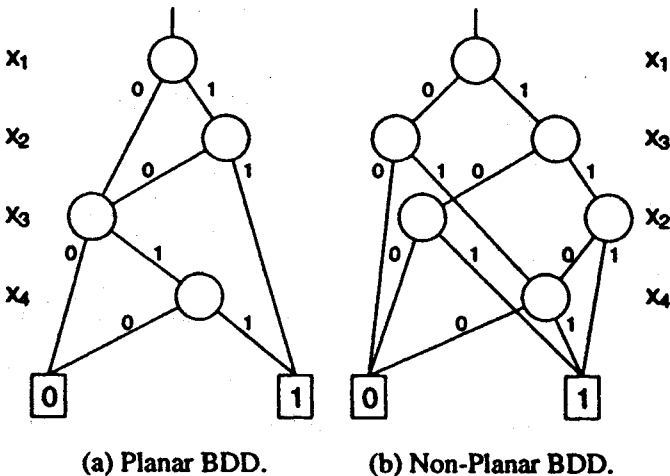

FIGURE 1 Example of how planarity in an OBDD depends on variable ordering.

1.1 Multiplexer Realization

Figure 2 shows multiplexer realizations of the OBDD's shown in Figure 1. In this case, the network's output occurs at the top of the figure. The circuit's inputs occur along the side and each determines which of the two multiplexer inputs are connected to the output (which are all directed upward). For each node in the ROBDD of the original function (Fig. 1), there is a multiplexer in the network realization (Fig. 2) and vice versa.

Note that if we ignore the lines for input variables, the network has no crossings. Figure 2(a), which is a multiplexer implementation of the crossing-free ROBDD of Figure 1(a), has no crossings. Figure 2(b), which is a multiplexer implementation of the ROBDD with crossings in Figure 1(b), also has crossings. In VLSI, crossings are expensive; they require additional channels and increase delay.

Thus, networks without crossings are particularly desirable. In this paper, we demonstrate classes of logic functions whose OMDD's and OBDD's are planar. This includes many functions common in logic

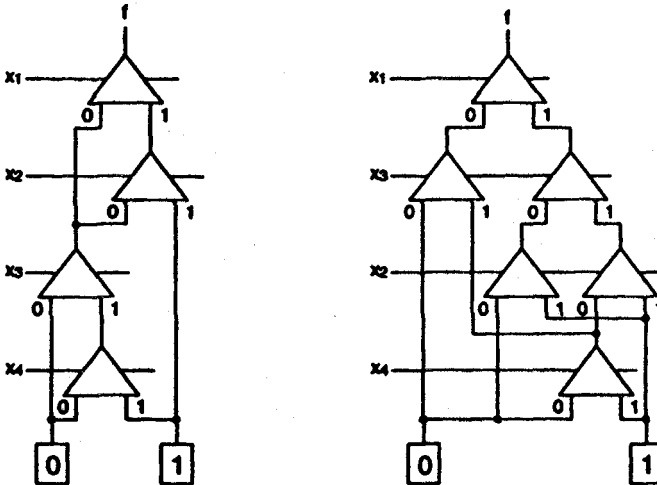

(a) A MUX network corresponding to Fig. 1 (a). (b) A MUX network corresponding to Fig. 1 (b).

FIGURE 2 The multiplexer implementation of an OBDD.

design practice and theory, including symmetric functions and certain classes of threshold functions.

2. PLANAR OMDD'S

In this section, we consider multiple-valued functions and their representation using decision diagrams. We show two classes of functions that have planar OMDD's. Then, we consider a function f whose OMDD is planar given that f can be decomposed in some specific way into subfunctions that have planar OMDD's. These results are used in Section 3 to identify functions that have planar OBDD's.

In preparation for the presentation of our main results, it is convenient to consider a special class of OMDD's.

DEFINITION 3 A complete OMDT (ordered multiple-valued decision tree) for function $f(x_1, x_2, \dots, x_n)$ is an OMDD with r^n terminal nodes, corresponding to all assignments of values to the variables x_1, x_2, \dots, x_n . Further, there are r^n distinct paths from the root node to the terminal nodes.

A complete OMDT also has $r^0 + r^1 + r^2 + \dots + r^n = r^{n+1} - 1/r - 1$ non-terminal nodes, corresponding to all partial assignments of values to variables starting from x_i . For example, when $r=2$, there is a node for every assignment of values to the tuple (x_1, x_2, \dots, x_n) of the form $0**\dots*$, $1***\dots*$, $00**\dots*$, $01**\dots*$, $10**\dots*$, $11**\dots*$, etc., where $*$ represents an, as yet, unassigned variable. In a complete OMDD, neither the merging nor the elimination rule has been applied. We can make the following observation.

LEMMA 1 *A complete OMDT is planar.*

Figure 3 shows a MUX network that corresponds to a complete OMDT. Each MUX has r primary inputs labeled $0, 1, \dots, r-1$, and one multiple-valued control input labeled x_i . At the bottom of this figure are logic values that correspond to terminal nodes in the OMDT. It is convenient to view these as truth table values. Indeed, from this, it follows that

LEMMA 2 *A complete OMDT realizes any multiple-valued function.*

The significance of the complete OMDT will be shown shortly. Because it is planar, the application of the merging and elimination

rules to a complete OMDT, given appropriate restrictions, produces an OMDD that is also planar. In this way, we can show useful results.

DEFINITION 4 Let $a = (a_1, a_2, \dots, a_n)$ and $b = (b_1, b_2, \dots, b_n)$ be vectors such that $a_i, b_i \in \{0, 1, \dots, r-1\}$, and let N_a and N_b be the base r numbers, $N_a = a_1 a_2 \dots a_n$ and $N_b = b_1 b_2 \dots b_n$, associated with a and b , respectively; i.e. $N_a = a_1 r^{n-1} + a_2 r^{n-2} + \dots + a_n r^0$ and $N_b = b_1 r^{n-1} + b_2 r^{n-2} + \dots + b_n r^0$. Then, $a \leq b$ iff $N_a \leq N_b$.

Example 2 For $n=3$ and $r=2$, $(0,0,0) \leq (0,0,1)$, and for $n=2$ and $r=3$, $(1,2) \leq (2,1)$.

DEFINITION 5 A function $f(x_1, x_2, \dots, x_n)$ is ℓ -monotonic (lexicographically monotonic) iff for $a = (a_1, a_2, \dots, a_n)$ and $b = (b_1, b_2, \dots, b_n)$, such that $a_i, b_i \in \{0, 1, \dots, r-1\}$, $a \leq b$ implies $f(a) \leq f(b)$, where logic values are viewed as integers.

Example 3 The switching functions AND and OR, $f_1(x_1, x_2) = x_1 x_2$ and $f_2(x_1, x_2) = x_1 \vee x_2$ are ℓ -monotonic.

DEFINITION 6 $f_1(x_1, x_2, \dots, x_n) \subseteq f_2(x_1, x_2, \dots, x_n)$ iff $f_1(a) \leq f_2(a)$ for all a .

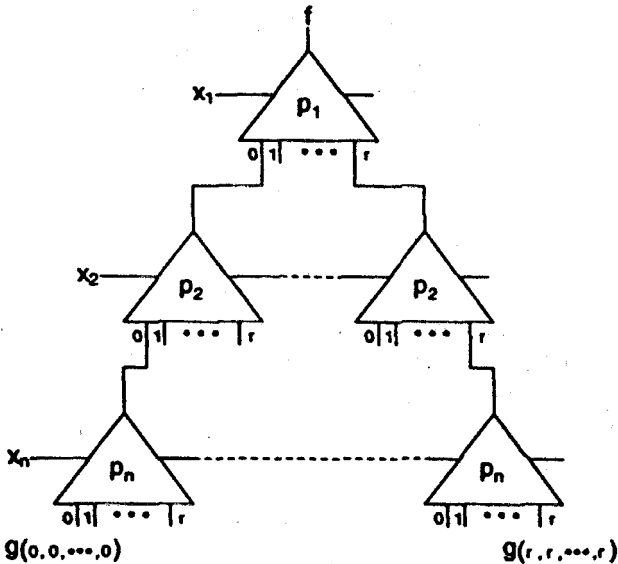

FIGURE 3 The multiplexer implementation of an example OBDD.

Example 4 The switching functions AND and OR, $f_1(x_1, x_2) = x_1 x_2$ and $f_2(x_1, x_2) = x_1 \vee x_2$, have the property $f_1 \subseteq f_2$.

LEMMA 3 *An ℓ -monotonic function has a planar ROMDD.*

Proof From Lemma 2, an ℓ -monotonic function has a complete OMDT, which, by Lemma 1, is planar. We now show that any application of the merging rule and the elimination rule preserves planarity. This is true of the elimination rule because if we merge all successor nodes of some node, the resulting OMDD is still planar. Consider merging two nodes η_1 and η_2 that represent the same function. Because the OMDD is planar, we can adjust nodes so that the nodes corresponding to a function on variables x_i , possibly x_{i+1} , possibly x_{i+2}, \dots , and possibly x_n are at the same level. Therefore, η_1 and η_2 can be assumed to be at the same level. Figure 4 shows how the elimination rule is applied to this case.

For any assignment of values to the variables in an OMDD, we have various values at nodes in the OMDD. Further, the logic values in a planar OMDD representation of an ℓ -monotonic function are monotone increasing left to right across the same level. From this and the fact that η_1 and η_2 realize the same function, it follows that any node η_i between η_1 and η_2 realize the same function as η_1 and η_2 . Therefore, we can merge η_1 and η_2 with all nodes in between. The resulting OMDD is planar. Repeated applications of the merging and elimination rules, therefore, ultimately produce a planar ROMDD.

Q.E.D.

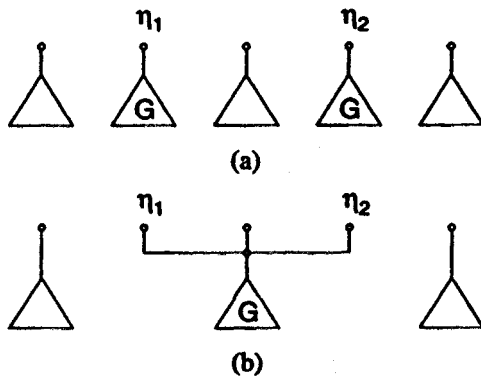

FIGURE 4 Derivation of a planar ROBDD.

DEFINITION 7 A multiple-valued function f is a monotone threshold function if f can be represented as follows. Given a set of positive integer-valued weights w_1, w_2, \dots, w_n , and a set of non-negative integer-valued thresholds T_0, T_1, \dots, T_r with the property $0 = T_0 \leq T_1 \leq T_2 \leq \dots \leq T_{r-1} \leq T_r = \sum_{i=1}^n w_i + 1$,

$$f(x_1, x_2, \dots, x_n) = j \text{ iff } T_j \leq \sum_{i=1}^n w_i x_i < T_{j+1}.$$

for $0 \leq j \leq r-1$, where values of x_i are viewed as integers. Let $(w_1, w_2, \dots, w_n; T_1, T_2, \dots, T_{r-1})$ be the weight-threshold vector of f .

Note that, when $r=2$, a monotone threshold function corresponds to a conventional switching threshold function.

Example 5 The switching functions AND and OR, $f_1(x_1, x_2) = x_1 x_2$ and $f_2(x_1, x_2) = x_1 \vee x_2$, are monotone threshold functions with weight-threshold vectors $(1, 1; 2)$ and $(1, 1; 1)$, respectively.

THEOREM 1 Let f be a monotone threshold function whose weight-threshold vector satisfies $w_i \geq \sum_{k=i+1}^n w_k(r-1)$ and $w_i \geq 1$. Then, f has a planar ROMDD.

Proof Consider two vectors $a = (a_1, a_2, \dots, a_n)$ and $b = (b_1, b_2, \dots, b_n)$, such that $a \leq b$. From the hypothesis,

$$w_i \geq \sum_{k=i+1}^n w_k(r-1),$$

and it follows that $a \leq b$ implies $\sum_{i=1}^n w_i a_i \leq \sum_{i=1}^n w_i b_i$. Thus, $f(a) \leq f(b)$, and f is ℓ -monotone. By Lemma 3, f has a planar ROMDD. Q.E.D.

Example 6 Consider the two-valued threshold function $f_T(x_1, x_2, x_3)$ with the weight-threshold vector $(2, 1, 1; T)$. Note that this function satisfies the conditions of Theorem 1. Thus, f_T has a planar ROBDD. Note that f_T represents the functions $f_T = x_1 x_2 x_3$ when $T=4$, $f_T = x_1(x_2 \vee x_3)$ when $T=3$, $f_T = x_1 \vee x_2 x_3$ when $T=2$, $f_T = x_1 \vee x_2 \vee x_3$ when $T=1$, and $f_T = 1$ when $T=0$. Figure 5(a) is the complete ROMDT of f_T for $T=2$ with edges labeled by weights instead of logic

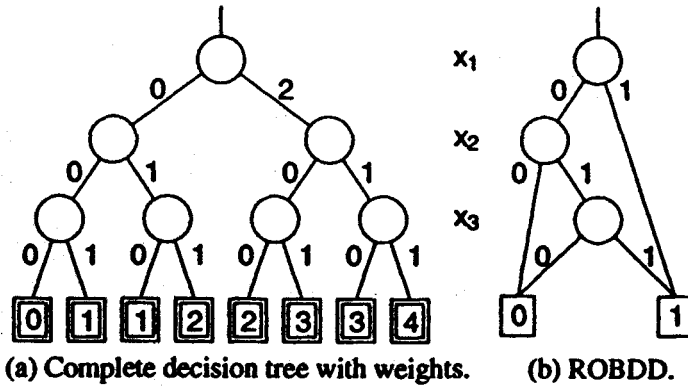

FIGURE 5 Example of the derivation of planar ROBDD for threshold function.

values. In this figure, the sum of the weights of edges in a path from the root node to a leaf node are shown at the leaf node. Figure 5(b) is the ROBDD for this function.

Example 7 Consider the three-valued two-variable monotone threshold function $f(x_1, x_2)$ with weight-threshold vector $(3, 1; T_1, T_2)$, where $T_1 < T_2$. Figure 6(a) shows how the four thresholds can be assigned values and how the corresponding function values occur from this assignment. Note that this function satisfies the conditions of Theorem 1. Figure 6(b) shows the complete OMDT of f with weighted edges, for the case where $T_1 = 2$ and $T_2 = 6$. Figure 6(c) shows the corresponding ROMDD.

Example 8 Consider the four variable switching function $f = x_1 \vee x_2(x_3 \vee x_4)$. Note that f is a threshold function with the weight-threshold vector $(5, 3, 1, 1; 4)$. This vector satisfies the condition of Theorem 1. So, the function with the ordering (x_1, x_2, x_3, x_4) has a planar ROBDD, as shown in Figure 7(a). Here, we have replaced logic value labels of edges with weight values. A different ordering (x_4, x_1, x_3, x_2) produces a non-planar ROBDD, as shown in Figure 7(b).

DEFINITION 8 The min and max \vee function have the property

$$A \cdot B = \min\{A, B\}$$

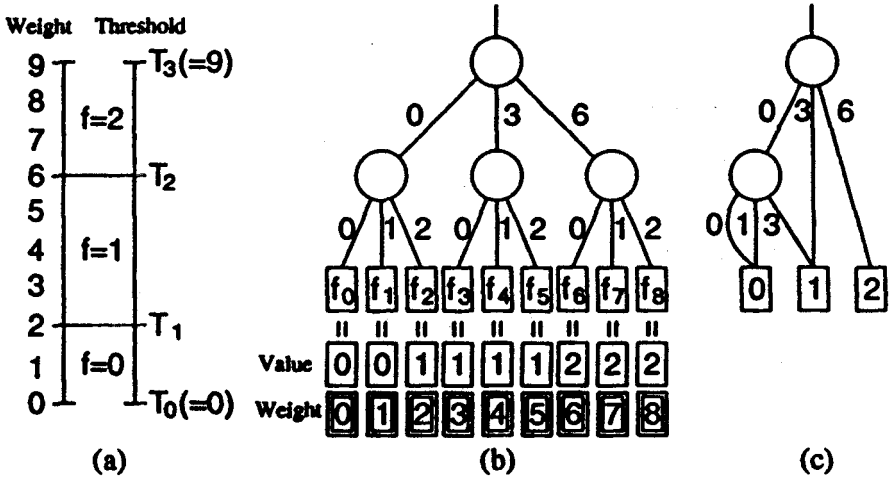

FIGURE 6 Derivation of a planar ROBDD for three-valued threshold function.

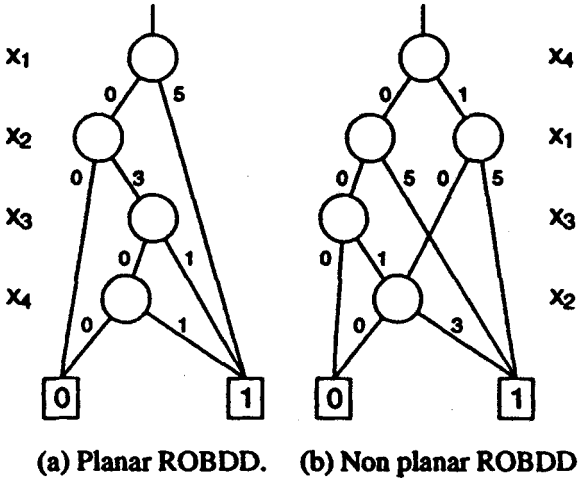

FIGURE 7 ROBDD's for $f = x_1 \vee x_2(x_3 \vee x_4)$.

$$A \vee B = \max\{A, B\}.$$

When $r=2$, the min and max function correspond to the AND and OR function, respectively.

DEFINITION 9 Let x be a variable that takes on values from $R = \{0, 1, \dots, r-1\}$, and let $S \subseteq R$. Then, $x^s = 0$ if $x \notin S$ and $x^s = r-1$ if $x \in S$. x^s is called the literal function.

THEOREM 2 Let $g(x_1, x_2, \dots, x_n)$ be a multiple-valued function that does not depend on x and let

$$f_1(x_1, x_2, \dots, x_n, x) = x^A \cdot g$$

$$f_2(x, x_1, x_2, \dots, x_n) = x^A \vee g,$$

where $A = \{a, a+1, \dots, r-1\}$. If g has a planar ROMDD, so also have f_1 and f_2 .

Proof Figures 8a and 8b show a planar realization of f_1 and f_2 . The planarity of the realizations of f_1 and f_2 follow from the planarity of g .

Q.E.D.

Note that if g is ℓ -monotone, then $f_1(x_1, x_2, \dots, x_n)$ and $f_2(x_1, x_2, \dots, x_n)$ are ℓ -monotone, and the result of Theorem 2, that f_1 and f_2 have planar ROMDD's can also be concluded from Lemma 3. Thus, Theorem 2 represents an extension of Lemma 3 to the case where g is not ℓ -monotone. We can achieve a further extension as follows.

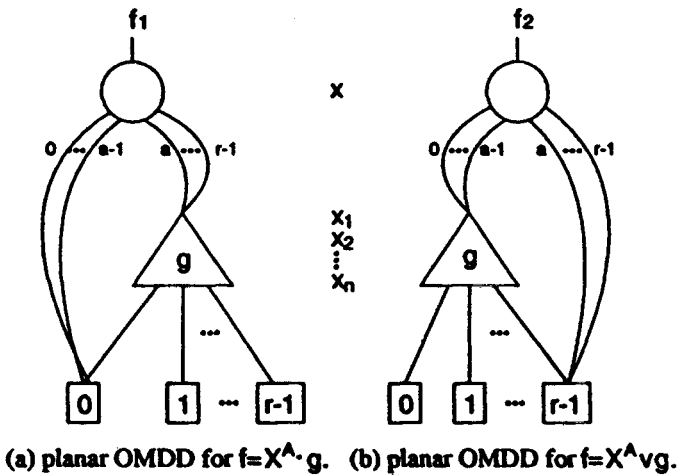

FIGURE 8 Planar ROMDD's for $f_1 = x^A \cdot g$ and $f_2 = x^A \vee g$.

THEOREM 3 Let $g(x_1, x_2, \dots, x_n)$ be a multiple-valued function that does not depend on x , such that $c_{low} \leq g \leq c_{high}$, for $c_{low}, c_{high} \in \{0, 1, \dots, r-1\}$. Let

$$f_1(x_1, x_2, \dots, x_n) = g_L(x)x^L \vee gx^M \vee g_H(x)x^H,$$

where $L = \{0, 1, \dots, l-1\}$, $M = \{l, l+1, \dots, h-1, h\}$, $H = \{h+1, h+2, \dots, r-1\}$, $g_L(x)$ and $g_H(x)$ are monotone (increasing) functions on x from L to $\{0, 1, \dots, c_{low}\}$ and from H to $\{c_{high}, c_{high} + 1, \dots, r-1\}$, respectively. If g has a planar ROMDD, so also has f .

Proof Figure 9 shows a planar realization of f . The planarity of f follows from the planarity of g , the fact that L, M and H are disjoint, and the fact that $g_L(x)$ and $g_H(x)$ are monotone increasing. Q.E.D.

Theorem 2 is a special case of Theorem 3, where $c_{low} = 0$, $c_{high} = r-1$, and either $l = a$ and $h = r-1$ ($f = x^A \cdot g$), or $l = 0$ and $h = a-1$ ($f = x^A \vee g$).

3. PLANAR OBDD'S

Because binary systems represents an important sub-class of multiple-valued systems, we consider them in this section. Specifically, we consider switching functions that have planar OBDD's.

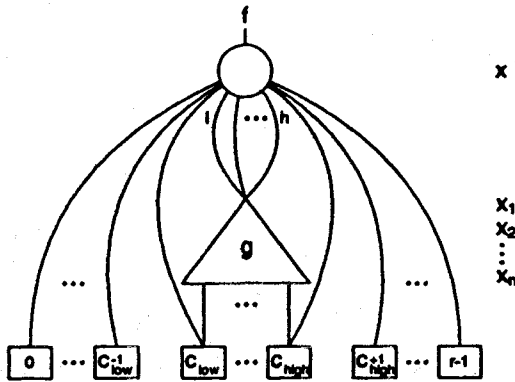

FIGURE 9 Decomposition of a planar ROMDD.

DEFINITION 10 A complete symmetric OBDD is an OBDD for a symmetric function that has a node for every i and m such that i of the m variables associated with the present level are 1, for $0 \leq i \leq m \leq n$.

Figure 10 shows that complete symmetric decision diagram for a symmetric function on 1,2 and 3 variables. A leaf node v_i can be reached if and only if i of the variables above it are 1. Thus, v_0 can be reached only if all variables are 0, v_1 can be reached only if exactly one is 1, etc.. Note that these OBDD's are planar. We have

LEMMA 4 A symmetric function has a complete symmetric OBDD.

DEFINITION 11 A voting function $S_{t/n}$ is a symmetric function that is 1 if and only if t or more of the n variables are 1, for $0 \leq t \leq n$.

LEMMA 5 A symmetric function has a planar ROBDD iff it is a voting function.

Proof (if) We can derive the ROBDD of f , a voting function, by applying the merging and elimination rules to a complete OBDD of f . Specifically, we can first apply the rules to produce a complete symmetric OBDD and second apply the rules to produce the final ROBDD. Since the complete symmetric OBDD is planar, it suffices to show that the second application of the rules preserves planarity. However, since f is a voting function, the leaf nodes of its complete symmetric OBDD consist of at most one string of 0's to the left of at most one string of 1's and the two rules preserve planarity.

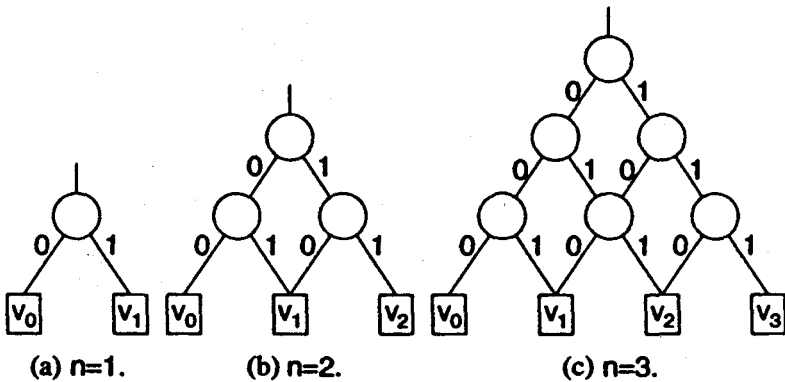

FIGURE 10 Complete symmetric decision diagrams.

(only if) On the contrary, suppose there is a symmetric function f that is not a voting function that has a planar ROBDD. We can first reduce the complete OBDT of f to a complete symmetric OBDD realizing f . If f is not a voting function or the complement of a voting function, there are two pair of adjacent leaf nodes labeled 01 and 10. These correspond to functions x_n and \bar{x}_n , where x_n is the last variable in the OBDD ordering. Since these nodes can never be combined, and they produce crossing edges at the lowest level of the OBDD, the ROBDD for f is not planar, a contradiction. If f is the complement of a voting function, there is one pair of adjacent nodes labeled 10 and none labeled 01. However, the merging and elimination rules yield an OBDD with the leaf node 1 to the left of the leaf node 0, and such an OBDD does not satisfy Restriction 1. Q.E.D.

Note the correlation of this result with Lemma 3, which states that an ℓ -monotone function has a planar ROMDD. That is, in the case of switching logic, the only ℓ -monotone *symmetric* functions are the AND and OR, which, by the repeated application of Theorem 2 have planar ROBDD's. However, Lemma 5 extends this to all voting functions by showing that they have planar ROBDD's.

Example 9 Figure 11 shows the construction of an ROBDD for a voting function, $S_{2/4}$, from a complete symmetric OBDD realization for $S_{2/4}$. It is interesting that the resulting ROBDD has a rectangular structure with $2 \cdot 3 = 6$ internal nodes. In general, a voting function $S_{t/n}$ has an ROBDD with a rectangular structure with $t \cdot (n - t + 1)$ internal nodes.

DEFINITION 12 Let $\Pi = \{X_1, X_2, \dots, X_n\}$ be a partition of $X = \{x_1, x_2, \dots, x_n\}$. A function is partially symmetric with respect to Π if f is unchanged by any permutation of the variables in X_i .

Given a partially symmetric function with respect to Π , we can form an OMDD that recognizes the various parts as nodes with output edges corresponding to the number of variables in X_i that are 1. We have

DEFINITION 13 Let f be a partially symmetric function with respect to $\Pi = \{X_1, X_2, \dots, X_n\}$. Then, f can be represented by a companion function $g(Y_1, Y_2, \dots, Y_n)$, where $Y_i \in \{0, 1, \dots, |X_i|\}$ represents the number of 1's in X_i , and $g \in \{0, 1\}$.

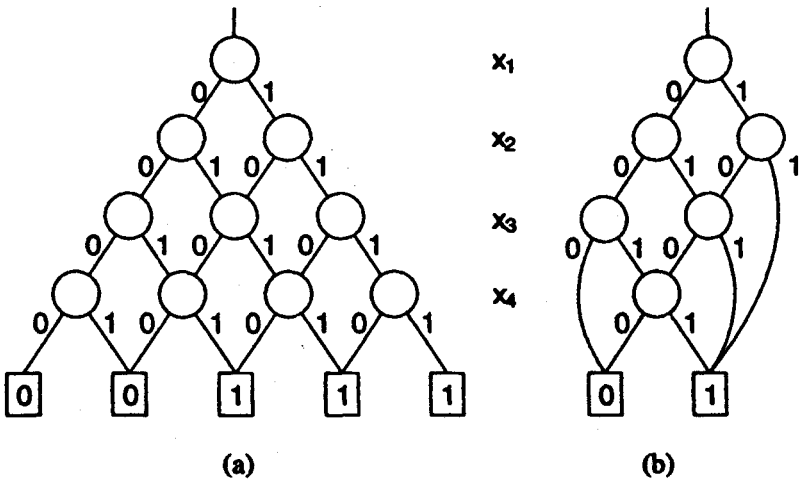

FIGURE 11 Construction of the ROBDD from a complete OBDD.

Example 10 Figure 12(a) shows the ROBDD of a six variable function f partially symmetric with respect to $\Pi = \{\{x_1\}, \{x_2, x_3\}, \{x_4, x_5, x_6\}\}$. Figure 12(b) shows the ROMDD of the companion function to f .

THEOREM 4 *If the companion function of a partially symmetric function f has a planar ROMDD, then f has a planar ROBDD.*

Proof Consider a planar ROMDD of some companion function g to a given partially symmetric function f . By replacing each node with a complete symmetric decision diagram, we form an OBDD for f . Any application of the merging or elimination rule preserves planarity; only nodes within one complete decision diagram can be merged or eliminated. Q.E.D.

Example 11 $f = (x_1 \vee x_2)(x_3x_4 \vee x_5x_6)$ is partially symmetric with respect to $X_1 = \{x_1, x_2\}$, $X_2 = \{x_3, x_4\}$ and $X_3 = \{x_5, x_6\}$. Let

$$Y_i = 0 \text{ if } X_i = \{0,0\}$$

$$Y_i = 1 \text{ if } X_i = \{0,1\} \text{ or } X_i = \{1,0\}, \text{ and}$$

$$Y_i = 2 \text{ if } X_i = \{1,1\}.$$

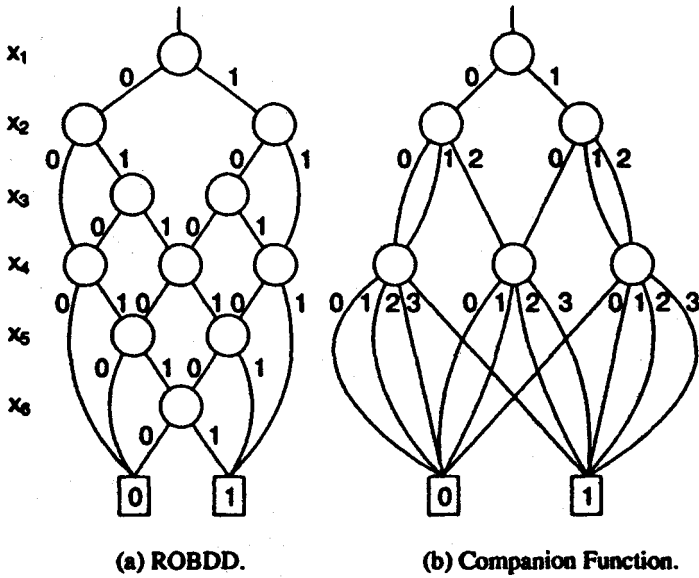

FIGURE 12 ROBDD of a partially symmetric function and its companion function.

Then, the companion function g is represented by

$$g(Y_1, Y_2, Y_3) = Y_1^{\{1,2\}} (Y_2^{\{2\}} \vee Y_3^{\{2\}}). \tag{1}$$

Figure 13(a) shows the planar ROMDD for g . By Theorem 4, we can conclude that the partially symmetric function associated with g has a planar ROMDD. Indeed, by replacing each node in the OBDD of g , we form a planar ROBDD for f , as shown in Figure 13(b). Note that f is not a threshold function. Also, note that companion functions can be generated iteratively. For example, (1) can be written as

$$h(Y_1, Z_1) = Y_1^{\{1,2\}} \cdot Z^{\{1,2\}},$$

where

$$Z^{\{1,2\}} = Y_2^{\{2\}} \vee Y_3^{\{2\}}.$$

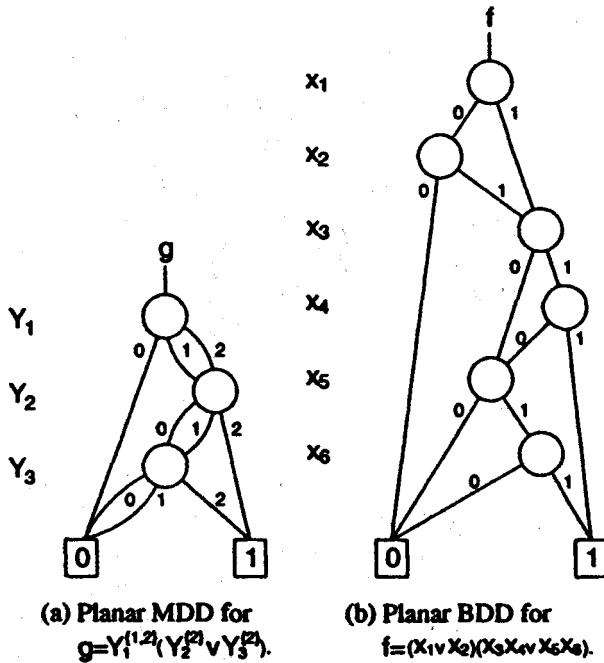

FIGURE 13 Derivation of a planar OBDD.

In this way, companion functions can be constructed from other companion functions.

Note that the converse of Theorem 4 is not true. That is, if the ROBDD of a partially symmetric function is planar, it does not follow that the companion function is planar. The function in Figure 12 represents a counterexample.

The bottom part of the ROBDD in Figure 12(a), labeled by x_4, x_5 , and x_6 realizes the three voting functions $x_4 x_5 x_6$, $x_4 x_5 \vee x_4 x_6 \vee x_5 x_6$, and $x_4 \vee x_5 \vee x_6$. Each function is realized by a separate node in the companion function. This observation can be made more general by observing that all voting functions can be realized in one ROMDD. For example, Figure 14 shows the realization of all voting functions on four variables. In general, we have

LEMMA 6 *The voting functions $S_{t/n}$, for $0 \leq t \leq n + 1$, collectively have a single planar ROBDD.*

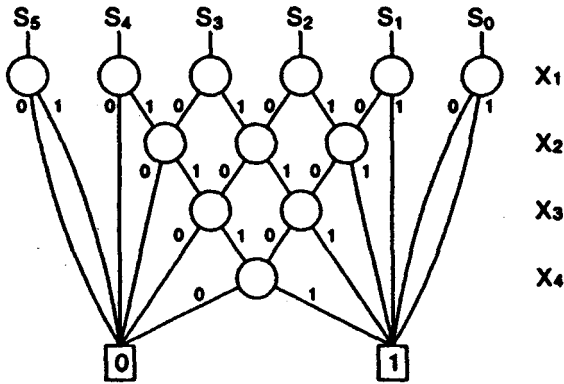

FIGURE 14 Planar realization of all voting functions on four variables.

The structure realizing one or more symmetric functions has the form shown in Figure 15 below. Figure 15(a) shows specific voting functions that are 1 iff t or more of the n variables are 1, for $n=5$ and $0 \leq t \leq 5$. The label t/n abbreviates $S_{t/n}$. Figure 15(b) shows a general implementation of this structure, in which two nodes η_1 and η_2 , realizing voting functions S_{t_1/n_1} and S_{t_2/n_2} respectively, are identified. In preparation for Theorem 5, we establish conditions under which η , (shown in Fig. 15(b) as a node external to the structure realizing S_{t_1/n_1} and S_{t_2/n_2}), η_1 and η_2 are part of a planar OBDD.

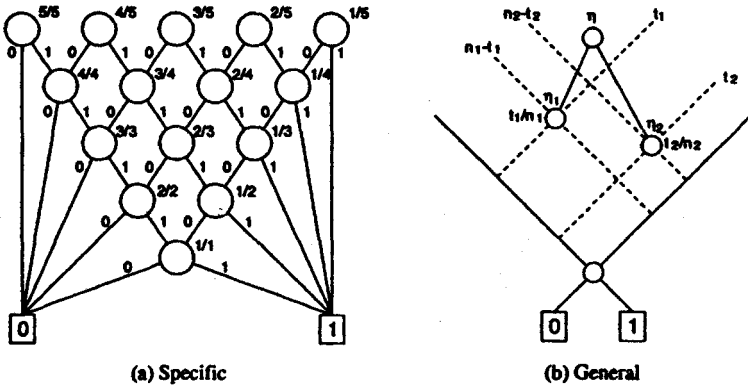

FIGURE 15 Structure realizing the voting functions.

LEMMA 7 Let $n_1 = |X_1|$ and $n_2 = |X_2|$. $S_{t_1/n_1}(X_1) \subseteq S_{t_2/n_2}(X_2)$, where either $X_1 \supseteq X_2$ or $X_2 \supseteq X_1$ iff $t_1 \geq t_2$ and $n_1 - t_1 \leq n_2 - t_2$.

Proof (only if) Assume $S_{t_1/n_1}(X_1) \subseteq S_{t_2/n_2}(X_2)$ and, on the contrary, assume either $t_1 < t_2$ or $n_1 - t_1 > n_2 - t_2$. Assume, $X_1 \supseteq X_2$; the argument for $X_2 \supseteq X_1$ is similar. Since $n_1 \geq n_2$, $t_1 < t_2$ implies $n_1 - t_1 > n_2 - t_2$, and it is sufficient to consider only the latter. Consider the voting function obtained by setting the $n_1 - n_2$ variables of $X_1 - X_2$ in $S_{t_1/n_1}(X_1)$ to 1. This forms a symmetric function $S_{t_1 - n_1 + n_2/n_2}(X_2)$. From $n_1 - t_1 > n_2 - t_2$, it follows that $t_1 - n_1 < t_2 - n_2$, and we can conclude that $t_1 - n_1 + n_2 < t_2$. Therefore $S_{t_1 - n_1 + n_2/n_2}(X_2)$ and $S_{t_2/n_2}(X_2)$ are distinct functions (since $t_1 - n_1 + n_2 \neq t_2$), such that $S_{t_1 - n_1 + n_2/n_2}(X_2) \supseteq S_{t_2/n_2}(X_2)$ (since $t_1 - n_1 + n_2 < t_2$), contradicting the assumption $S_{t_1/n_1}(X_1) \subseteq S_{t_2/n_2}(X_2)$.

(if) Assume $t_1 \geq t_2$ and $n_1 - t_1 \leq n_2 - t_2$. Assume $X_1 \supseteq X_2$; the argument for $X_2 \supseteq X_1$ is similar. Consider any assignment of values to $X_1 - X_2$ in $S_{t_1/n_1}(X_1)$. The resulting function $S_{t/n_2}(X_2)$ has the property $t \geq t_1 - n_1 + n_2$, the lower bound on t corresponding to assigning 0 to all $n_1 - n_2$ variables in $X_1 - X_2$. But, from $n_1 - t_1 \leq n_2 - t_2$, $t \leq t_2$, and it follows that $S_{t/n_2}(X_2) \subseteq S_{t_2/n_2}(X_2)$, from which we can conclude that $S_{t_1/n_1}(X_1) \subseteq S_{t_2/n_2}(X_2)$. Q.E.D.

The significance of Lemma 7 can be seen as follows. Suppose that exactly one of the two conditions of Lemma 7 is *not* fulfilled. That is, either $t_1 < t_2$ or $n_1 - t_1 > n_2 - t_2$. Then either η_1 exists within the OBDD that realizes η_2 or vice versa, respectively. Therefore, one of the edges from η must cross edges in the OBDD structure. When both conditions are not fulfilled, the roles of η_1 and η_2 are reversed; i.e. $S_{t_1/n_1}(X_1) \supseteq S_{t_2/n_2}(X_2)$.

THEOREM 5 Let Π be a two-part partition $\{X_1, X_2\}$, such that $X_1 = \{x_1, x_2, \dots, x_k\}$ and $X_2 = \{x_{k+1}, x_{k+2}, \dots, x_n\}$. Let $\Psi_i(X_1)$ be the symmetric function that is 1 when exactly i of the variables in X_1 are 1 and is 0 otherwise. Let $S_{t_i/n_i}(X_{2,i})$ be a voting function, where $X_{2,i} \subseteq X_2$. Let f be represented as

$$f(X_1, X_2) = \bigvee_{i=0}^k \Psi_i(X_1) S_{t_i/n_i}(X_{2,i}), \tag{2}$$

where $S_{t_i/n_i}(X_{2,i}) \subseteq S_{t_{i+1}/n_{i+1}}(X_{2,i+1})$. Then, f has a planar ROBDD.

Proof By Lemma 4, Ψ_i , a symmetric function, has a complete symmetric decision diagram, which is planar. Indeed, any set of symmetric

functions on X_1 can be realized. By Lemma 6, all S_{t_i/n_i} have planar ROBDD's. Figure 16 shows an OBDD in which the upper block realizes the Ψ_i 's and the lower block realizes the S_{t_i/n_i} 's. By connecting terminals between the two blocks, we have an ROBDD realization of $f(X_1, X_2)$. Crossings among these connections are precluded by Lemma 7. Application of the merging and elimination rules preserves planarity. Q.E.D.

A special case of Theorem 5 occurs when $X_{2,i} = X_2$, for all i . As an example of this, consider

Example 12 Consider the function $f = (x_1 \oplus x_2)x_3x_4 \vee x_1x_2(x_3 \vee x_4)$. f is partially symmetric with respect to $X_1 = (x_1, x_2)$ and $X_2 = (x_3, x_4)$. Note that f can be represented as $f(X_1, X_2) = \Psi_0(X_1)S_{3/2}(X_2) \vee \Psi_1(X_1)S_{2/2}(X_2) \vee \Psi_2(X_1)S_{1/2}(X_2)$, where $\Psi_0(X_1) = \bar{x}_1\bar{x}_2$, $\Psi_1(X_1) = x_1 \oplus x_2$, $\Psi_2(X_1) = x_1x_2$, $S_3(X_2) = 0$, $S_2(X_2) = x_3x_4$, and $S_1(X_2) = x_3 \vee x_4$. Thus, by Theorem 5, f has a planar OBDD, Figure 16 shows this OBDD.

Another special case of Theorem 5 occurs for a specific type of threshold function.

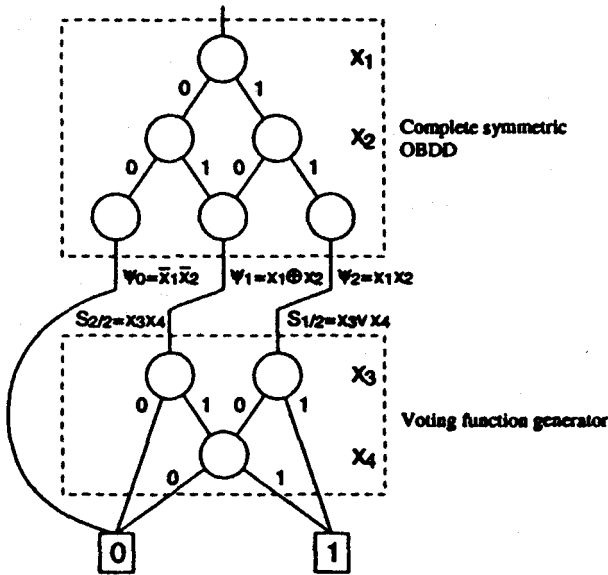

FIGURE 16 ROBDD for $f = (x_1 \oplus x_2)x_3x_4 \vee x_1x_2(x_3 \vee x_4)$.

COROLLARY 1 *A monotone increasing threshold function having at most two different weights has a planar ROBDD.*

Proof

1. A monotone increasing threshold function f having only one weight is a voting function. Thus, by Lemma 5, f has a planar ROBDD.
2. Suppose that f has a weight-threshold vector $(w_1, w_2, \dots, w_{k+1}, \dots, w_n; T)$, where $w_1 = w_2 = \dots = w_k < w_{k+1} = w_{k+2} = \dots = w_n$. In this case, f is partially symmetric with respect to $X_1 = \{x_1, x_2, \dots, x_k\}$ and $X_2 = \{x_{k+1}, x_{k+2}, \dots, x_n\}$, and f can be represented in the form (2). Since f is a monotone increasing function, we can assume that $S_{t_i/n_i}(X_2) \subseteq S_{t_{i+1}/n_{i+1}}(X_2)$. Thus, by Theorem 5, f has a planar ROBDD.

Q.E.D.

LEMMA 8 *Let $X = \{x_1, x_2, \dots, x_n\}$. Let $\phi_i(X)$ ($i=0, 1, \dots, t$) be threshold functions with a weight-threshold vector $(w_1, w_2, \dots, w_n; T)$, where $w_1 = 1$ and*

$$w_i \geq \sum_{j=i+1}^n w_j \quad \text{and} \quad \phi_i(X) \supseteq \phi_{i+1}(X).$$

Then, both $\Psi_i(X) = \phi_i(X) \cdot \overline{\phi_{i+1}}(X)$ ($i=1, 2, \dots, t-1$) and $\Psi_t = \phi_t(X)$ can be represented in a planar OBDD.

Example 13 Consider the following threshold functions, which are represented by the weight-threshold vector $(2, 1, 1; T)$.

$$\phi_0(X) = 1 \quad (T=0)$$

$$\phi_1(X) = x_1 \vee x_2 \vee x_3 \quad (T=1)$$

$$\phi_2(X) = x_1 \vee x_2 x_3 \quad (T=2)$$

$$\phi_3(X) = x_1(x_2 \vee x_3) \quad (T=3)$$

$$\phi_4(X) = x_1 x_2 x_3 \quad (T=4)$$

The Ψ functions are formed as follows.

$$\Psi_4(X) = \phi_4(X) = x_1x_2x_3$$

$$\Psi_3(X) = \phi_3(X) \cdot \bar{\phi}_4(X) = x_1(x_2 \oplus x_3)$$

$$\Psi_2(X) = \phi_2(X) \cdot \bar{\phi}_3(X) = \bar{x}_1x_2x_3 \vee x_1\bar{x}_2\bar{x}_3$$

$$\Psi_1(X) = \phi_1(X) \cdot \bar{\phi}_2(X) = \bar{x}_1(x_2 \oplus x_3)$$

$$\Psi_0(X) = \phi_0(X) \cdot \bar{\phi}_1(X) = \bar{x}_1\bar{x}_2\bar{x}_3.$$

Figure 5(a) shows the decision tree with weights. By merging the terminal nodes that represent the same weight-sum, we achieve the ROBDD, as shown in Figure 17.

We can extend Theorem 5 to the case where the subfunctions on X_2 are symmetric functions.

THEOREM 6 *Suppose that $X = (X_1, X_2)$ is a partition of variables $X = (x_1, x_2, \dots, x_n)$. If a function f can be represented as*

$$f(X_1, X_2) = \bigvee_{i=0}^t \Psi_i(X_1)S_{a_i}(X_2), \tag{3}$$

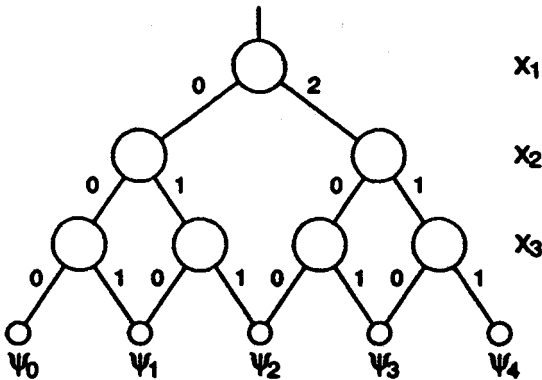

FIGURE 17 ROBDD generating Ψ_i 's.

where $S_{a_i}(X_2)$ is a symmetric function satisfying $S_{a_i}(X_2) \subseteq S_{a_{i+1}}(X_2)$, and $\Psi_i (i = 1, 2, \dots, t)$ is a function as defined in Theorem 5, then f has a planar OBDD.

Proof We can prove this theorem in a similar way to Theorem 5.

Q.E.D.

COROLLARY 2 Suppose that a monotone increasing threshold function f has a weight-threshold vector $(w_1, w_2, \dots, w_k, w_{k+1}, \dots, w_n; T)$, where $w_1 = 1$,

$$w_i \geq \sum_{j=i+1}^k w_j, \quad (i=1, 2, \dots, k-1), \text{ and}$$

$w_k = w_{k+1} = \dots = w_n$. Then, f has a planar ROBDD.

Proof Note that f can be written in the form (3). Because f is monotone increasing, we can assume that $S_{a_i}(X_2) \subseteq S_{a_{i+1}}(X_2)$. Thus, by Theorem 6, f has a planar ROBDD. Q.E.D.

Example 14 Consider the 5-variable function with the weight-threshold vector $(4, 3, 3, 2, 1; 6)$. f is symmetric with respect to $X_2 = \{x_2, x_3\}$. Also, the weights for $X_1 = \{x_1, x_4, x_5\}$ satisfy the conditions of Theorem 6. Thus, f can be represented as

$$f = \bigvee_{i=0}^7 \Psi_i(X_1) S_{a_i}(X_2).$$

Figure 18 shows the planar OBDD for f . The upper block generates Ψ_i , and the lower block generates S_{a_i} . Note that each edge has a weight. In each path from the root node to the constant 1, the sum of the weights is greater than or equal to 6. On the other hand, in each path from the root node to the constant 0, the sum of the weights is less than 6. We can form an ROBDD without crossings.

THEOREM 7 All the monotone increasing functions of up to four variables have planar ROBDD's.

Proof From the table of NPN-representative functions of four variables [3], we can identify all the monotone increasing functions. By using Theorem 3, Corollaries 1 and 2, we can verify that all the repre-

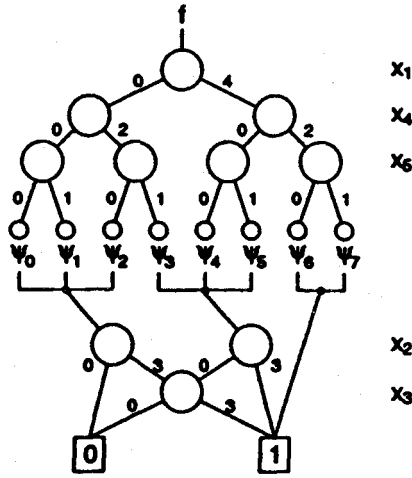

FIGURE 18 OBDD for a threshold function.

sentative functions have planar ROBDD's, except for $g = x_1(x_2 \vee x_4) \vee x_3x_4$. But, g has a planar OBDD as shown in Figure 19. Q.E.D.

THEOREM 8 *All the monotone increasing threshold functions of up to five variables have planar ROBDD's.*

Proof From the table of D-representative functions of NPN-equivalence classes up to five variables [5], we can verify the theorem. There

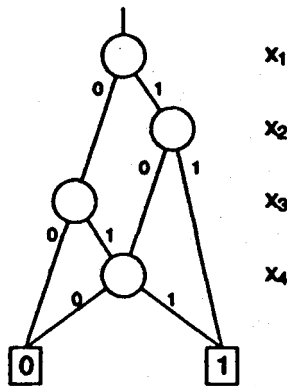

FIGURE 19 ROBDD for $f = x_1(x_2 \vee x_4) \vee x_3x_4$.

are 62 representative functions. By using Theorem 3, Corollaries 1 and 2, we can show that 59 functions have planar OBDD's. For the other 3 functions, we obtained their planar ROBDD's by inspection. Q.E.D.

4. CONCLUDING REMARKS

By Restriction 1, all OBDD's in this paper have the property that 1-edges emerge to the right and 0-edges emerge to the left. By lifting this restriction, we can extend our results as follows.

LEMMA 9 *f has a planar ROBDD iff f^d has a planar ROBDD, where f^d is the dual of f .*

Proof In the ROBDD of f , complement all (node and edge) labels. The resulting OBDD is an ROBDD for f^d and is planar. Q.E.D.

Note that rotation of the ROBDD obtained from the above result about a vertical line produces an ROBDD that again satisfies Restriction 1.

However, the lifting of Restriction 1 also allows us to extend our results for monotone increasing functions to unate functions. Specifically, given a unate function f , we can convert f into a monotone increasing function by complementing certain variables. In the domain of the OBDD, this corresponds to interchanging the 0 and 1 labels associated with the complemented variables. Since relabeling edges preserves planarity, if the original OBDD had no crossing edges, so also with the relabeled OBDD.

For a given monotone increasing function, in most cases, we can find a planar ROBDD among minimum ROBDD's. However, some functions require additional nodes to make their OBDD's planar. In the past, reduction of the number of nodes was the major subject in the optimization of OBDD's. However, in implementing multi-level networks directly from the OBDD's, the planarity of OBDD's is also important, since crossings produces delay in LSIs.

Acknowledgments

This research was supported in part by the Japan Society for the Promotion of Science, the Ministry of Education, Science and Culture of

Japan and in part by the Tateishi Science and Technology Foundation. Mr. Munehiro Matsuura edited the text and figures using L^AT_EX.

References

- [1] Akers, S. B. (June 1978). "Binary decision diagram", *IEEE Trans. on Computers*, C-27, 509–516.
- [2] Bryant, R. E. (1986). Graph-Based Algorithms for Boolean Function Manipulation, *IEEE Trans. on Computers*, C-35, 667–691.
- [3] Harrison, M. A. (1965). *Introduction to Switching and Automata Theory*, McGraw-Hill, New York.
- [4] Miller, D. M. (May 1993). Multiple-Valued Logic Design Tools, *Proc. of the 23rd International Symp. on Multiple-Valued Logic*, 2–11.
- [5] Muroga, S., Ibaraki, H. and Kitahashi, T. (June 1976). *Threshold Logic* (in Japanese), Sangyo Tosho.
- [6] Sasao, T. (May 1992). Optimization of Multiple-Valued AND-EXOR Expressions Using Multiple-Place Decision Diagrams, *Proc. of the 22nd International Symp. on Multiple-Valued Logic*, 451–458.