



**NAVAL
POSTGRADUATE
SCHOOL**

MONTEREY, CALIFORNIA

THESIS

**LONG-RANGE PRECISION-STRIKE CRUISE MISSILES
IN NATO OPERATIONS**

by

Antonio T. Jones

March 2014

Thesis Advisor:
Second Reader:

David S. Yost
Mikhail Tsyarkin

Approved for public release; distribution is unlimited

THIS PAGE INTENTIONALLY LEFT BLANK

REPORT DOCUMENTATION PAGE			<i>Form Approved OMB No. 0704-0188</i>	
Public reporting burden for this collection of information is estimated to average 1 hour per response, including the time for reviewing instruction, searching existing data sources, gathering and maintaining the data needed, and completing and reviewing the collection of information. Send comments regarding this burden estimate or any other aspect of this collection of information, including suggestions for reducing this burden, to Washington headquarters Services, Directorate for Information Operations and Reports, 1215 Jefferson Davis Highway, Suite 1204, Arlington, VA 22202-4302, and to the Office of Management and Budget, Paperwork Reduction Project (0704-0188) Washington DC 20503.				
1. AGENCY USE ONLY (Leave blank)		2. REPORT DATE March 2014	3. REPORT TYPE AND DATES COVERED Master's Thesis	
4. TITLE AND SUBTITLE LONG-RANGE PRECISION-STRIKE CRUISE MISSILES IN NATO OPERATIONS			5. FUNDING NUMBERS	
6. AUTHOR(S) Antonio T. Jones				
7. PERFORMING ORGANIZATION NAME(S) AND ADDRESS(ES) Naval Postgraduate School Monterey, CA 93943-5000			8. PERFORMING ORGANIZATION REPORT NUMBER	
9. SPONSORING /MONITORING AGENCY NAME(S) AND ADDRESS(ES) N/A			10. SPONSORING/MONITORING AGENCY REPORT NUMBER	
11. SUPPLEMENTARY NOTES The views expressed in this thesis are those of the author and do not reflect the official policy or position of the Department of Defense or the U.S. Government. IRB Protocol number ____N/A____.				
12a. DISTRIBUTION / AVAILABILITY STATEMENT Approved for public release; distribution is unlimited			12b. DISTRIBUTION CODE	
13. ABSTRACT (maximum 200 words) In 1949, NATO was established as a military alliance organized to protect its members from aggression or coercion by its adversaries to the East. However, after the collapse of the Soviet Union, the geostrategic context for NATO transformed significantly, with a new set of security threats (ethnic conflicts, terrorism, nuclear proliferation, organized crime, etc.). For NATO to remain relevant, its members had to sustain its overall purpose of collective defense and contribute to collective security in the post-Cold War world, in which several internal and external factors have transformed. While the Alliance remains a collective defense organization, the Allies have nonetheless assumed additional roles in conflict prevention and crisis management. In its crisis management role, advances in military technology have afforded NATO the opportunity to utilize a significant strategic weapon, the Tomahawk Land Attack Missile (TLAM). For NATO, the TLAM has demonstrated its utility for specific purposes; and it has transformed the landscape of modern warfare. This weapon has allowed NATO to enhance its force projection capability, while minimizing risks for Alliance personnel (aircrews and ground troops) when conducting strike operations.				
14. SUBJECT TERMS NATO, precision-guided munitions, cruise missiles, Tomahawk Land Attack Missile			15. NUMBER OF PAGES 91	
			16. PRICE CODE	
17. SECURITY CLASSIFICATION OF REPORT Unclassified	18. SECURITY CLASSIFICATION OF THIS PAGE Unclassified	19. SECURITY CLASSIFICATION OF ABSTRACT Unclassified	20. LIMITATION OF ABSTRACT UU	

NSN 7540-01-280-5500

Standard Form 298 (Rev. 2-89)
Prescribed by ANSI Std. Z39-18

THIS PAGE INTENTIONALLY LEFT BLANK

Approved for public release; distribution is unlimited

**LONG-RANGE PRECISION-STRIKE CRUISE MISSILES IN NATO
OPERATIONS**

Antonio T. Jones
Lieutenant, United States Navy
B.A., University of Northwood, 2007

Submitted in partial fulfillment of the
requirements for the degree of

MASTER OF ARTS IN SECURITY STUDIES (EUROPE AND EURASIA)

from the

**NAVAL POSTGRADUATE SCHOOL
March 2014**

Author: Antonio T. Jones

Approved by: David S. Yost
Thesis Advisor

Mikhail Tsypkin
Second Reader

Mohammed Hafez
Chair, Department of National Security Affairs

THIS PAGE INTENTIONALLY LEFT BLANK

ABSTRACT

In 1949, NATO was established as a military alliance organized to protect its members from aggression or coercion by its adversaries to the East. However, after the collapse of the Soviet Union, the geostrategic context for NATO transformed significantly, with a new set of security threats (ethnic conflicts, terrorism, nuclear proliferation, organized crime, etc.). For NATO to remain relevant, its members had to sustain its overall purpose of collective defense and contribute to collective security in the post-Cold War world, in which several internal and external factors have transformed. While the Alliance remains a collective defense organization, the Allies have nonetheless assumed additional roles in conflict prevention and crisis management. In its crisis management role, advances in military technology have afforded NATO the opportunity to utilize a significant strategic weapon, the Tomahawk Land Attack Missile (TLAM). For NATO, the TLAM has demonstrated its utility for specific purposes; and it has transformed the landscape of modern warfare. This weapon has allowed NATO to enhance its force projection capability, while minimizing risks for Alliance personnel (aircrews and ground troops) when conducting strike operations.

THIS PAGE INTENTIONALLY LEFT BLANK

TABLE OF CONTENTS

I.	INTRODUCTION.....	1
A.	MAJOR RESEARCH QUESTIONS	1
B.	IMPORTANCE	2
C.	PROBLEMS	2
D.	LITERATURE REVIEW.....	4
1.	Precision-Guided Munitions	4
2.	Operation Deliberate Force.....	9
3.	Operation Allied Force	11
4.	Operation Unified Protector.....	15
E.	METHODS AND SOURCES	18
F.	THESIS OVERVIEW	19
II.	LONG-RANGE PRECISION-STRIKE CRUISE MISSILES IN NATO OPERATIONS	21
A.	DEFINITION OF A CRUISE MISSILE.....	21
B.	THE ORIGINS OF CRUISE MISSILES.....	22
C.	THE TOMAHAWK LAND ATTACK MISSILE.....	26
1.	Tomahawk Land Attack Missile “A” Variant.....	29
2.	Tomahawk Land Attack Missile “C” Variant.....	30
3.	Tomahawk Land Attack Missile “D” Variant.....	31
4.	Tomahawk Land Attack Missile “E” Variant.....	32
III.	NATO OPERATIONS IN WHICH CRUISE MISSILES HAVE BEEN EMPLOYED	35
A.	OPERATION DELIBERATE FORCE (BOSNIA CAMPAIGN).....	35
B.	OPERATION ALLIED FORCE (KOSOVO CAMPAIGN)	39
C.	OPERATION UNIFIED PROTECTOR (LIBYA CAMPAIGN).....	44
IV.	THE CAPABILITIES GAP OF THE ALLIANCE	51
V.	CRUISE MISSILE TRENDS.....	59
A.	RUSSIA.....	60
B.	INDIA.....	60
C.	IRAN.....	60
D.	TAIWAN	61
E.	PAKISTAN	61
F.	GERMANY	61
G.	FRANCE	62
VI.	CONCLUSION	65
	LIST OF REFERENCES.....	67
	INITIAL DISTRIBUTION LIST	73

THIS PAGE INTENTIONALLY LEFT BLANK

LIST OF FIGURES

Figure 1.	JCMPO Organizational Structure	25
Figure 2.	Tomahawk Land Attack Missile	27
Figure 3.	Tomahawk Land Attack Missile (TLAM-N)	30
Figure 4.	Tomahawk Land Attack Missile (TLAM-C)	31
Figure 5.	Tomahawk Land Attack Missile (TLAM-D)	32
Figure 6.	Tomahawk Land Attack Missile (TLAM-E).....	34

THIS PAGE INTENTIONALLY LEFT BLANK

LIST OF TABLES

Table 1.	Current Tomahawk Land Attack Missiles	29
----------	---	----

THIS PAGE INTENTIONALLY LEFT BLANK

LIST OF ACRONYMS AND ABBREVIATIONS

BSA	Bosnian Serb Army
DSMAC	digital scene matching area correlation
GLCM	Ground Launched Cruise Missile
GPS	Global Positioning System
INS	Inertial Navigation System
IOC	initial operational capability
SLCM	Sea Launched Cruise Missile
NATO	North Atlantic Treaty Organization
NM	nautical miles
OAF	Operation Allied Force
ODF	Operation Deliberate Force
OOD	Operation Odyssey Dawn
OUP	Operation Unified Protector
TERCOM	terrain contour matching
TLAM	Tomahawk Land Attack Missile
TLAM-C	Unitary Warhead
TLAM-D	Bomblet Dispersal Warhead
TLAM-E	Tactical Tomahawk
TLAM-N	Nuclear Warhead
UAV	unmanned aerial vehicle
UN	United Nations
UNPROFOR	United Nations Protection Force

THIS PAGE INTENTIONALLY LEFT BLANK

ACKNOWLEDGMENTS

First and foremost, I would like to express my sincere gratitude and appreciation to my thesis advisor, Professor David Yost. You have been an incredible supporter in my endeavors. Your countless instances of advice and guidance have been tremendous for me, and because of that, I am truly appreciative. I would also like to thank the staff of the National Security Affairs department, especially Commander Jorge Garcia, Professor Mikhail Tsytkin, Professor Zachary Shore, Professor Helen Anderson, Professor Robert Looney, Professor Victoria Clement, Professor Sophal Ear, Professor Ryan Gingeras, and Professor Robert Weiner. Thank you for not allowing me to quit. Thank you for the many conversations, small and big. I came to the Naval Postgraduate School (NPS) with an oversize ego and assumed I could do this on my own. However, I was so wrong. Because of you, I am leaving NPS a better individual, professionally and personally.

A special thanks to my special little lady, Adrianna. Though you cannot read yet, daddy is sorry for the time spent away from you, but I promise you that there will be brighter days in the future.

And lastly, my incredible wife. Words can't explain how important you have been in this process. For the last year-and-a-half, you have allowed me to cry on your shoulder. There were days I wanted to give up, but because of your encouragement, guidance, and support, I found a way to make it. I love you so much.

THIS PAGE INTENTIONALLY LEFT BLANK

I. INTRODUCTION

A. MAJOR RESEARCH QUESTIONS

Since the collapse of the Soviet Union, the character of the North Atlantic Treaty Organization (NATO) has transformed considerably. The NATO allies have undertaken a greater number of missions, and have operated in a larger geographical region in crisis management and conflict prevention. The enhancement of military technology has modified the way in which NATO conducts operations, and this has included the employment of long-range precision-guided munitions (PGMs).¹ PGMs have become effective weapons for NATO, and continue to be an essential instrument, as seen in the 2011 Libya operations. Because of their versatility, PGMs have demonstrated their utility for specific purposes and have transformed the landscape of modern warfare in NATO operations. These new weapons have allowed NATO to enhance its force projection capability, while minimizing the loss of life (aircrews and ground troops) when conducting strike operations. The Vice President of the United States, Joseph R. Biden Jr., pointed out that the U.S. military “didn’t lose a single life” in the Libya operations and described the use of these new weapons as follows: “this is more of the prescription for how to deal with the world as we go forward than it has been in the past.”²

Precision-guided munitions have been effective in attacking soft and hard targets, and have been reliable in preparing the battlefield. As newer generations of PGMs continue to be developed and integrated within NATO’s military posture, allies such as the United States and the United Kingdom will continue to utilize them. To what extent does this represent a new way of war for NATO? Have the

¹This thesis focuses on long-range cruise missiles. The term “PGM” is employed to refer to long-range cruise missiles, not to short-range PGMs such as anti-tank weapons and air-to-air missiles.

²Joseph R. Biden Jr. quoted in Thom Shanker and Eric Schmitt, “Seeing Limits to ‘New Kind of War in Libya,’” *The New York Times*, October 21, 2011, last accessed August 20, 2013, http://www.nytimes.com/2011/10/22/world/africa/nato-war-in-libya-shows-united-states-was-vital-to-toppling-qaddafi.html?_r=3&.

allies come to rely on long-range precision-strike cruise missiles for the suppression of enemy air defenses and other purposes?

B. IMPORTANCE

Today, the complexity of modern warfare is changing, as advancements in military technology have afforded not only NATO, but also non-NATO countries, distinctive advantages in combat. PGMs and unmanned aerial vehicles (UAVs) have, for example, changed the way in which war is fought, and have become a fundamental part of military postures worldwide. As Thomas G. Mahnken stated in *Technology and the American Way of War Since 1945*:

On the battlefield of the future, enemy forces will be located, tracked, and targeted almost instantaneously through the use of data links, computer assisted intelligence evaluation and automated fire control. With first round probabilities approaching certainty, and with surveillance devices that can continually track the enemy, the need for large forces will be less important.³

Today, the heavy emphasis placed on technology can be seen in the range of NATO operations conducted since the collapse of the Soviet Union. Technology has provided NATO not only the ability to respond effectively in crisis management and conflict prevention operations, but also the ability to gain a significant military advantage over its adversaries.

C. PROBLEMS

Since the collapse of the Soviet Union in 1991, the purposes and identity of NATO have evolved. Since the early 1990s, the allies have conducted crisis management and conflict prevention actions outside the NATO collective defense area specified in Article 6 of the Washington Treaty of 1949.⁴ In interventions from Operation Deliberate Force in Bosnia in 1995 to Operation

³Thomas G. Mahnken, *Technology and the American Way of War Since 1945* (New York: Columbia University Press, 2008), 1.

⁴Robert Owen, *Deliberate Force: A Case Study in Effective Air Campaigning*, Final Report of the Air University Balkans Air Campaign Study (Maxwell Air Force Base, Alabama: Air University Press, 2000), 65.

Unified Protector in Libya in 2011, the use of PGMs has been instrumental, specifically Tomahawk Land Attack Missiles (TLAMs). However, the utilization of this strategic weapon by NATO has raised two issues.

The first issue is contextual: NATO adversaries are now acquiring them, too. In his article, "Cruise Missiles: Everyone's Building Them," John Reed states:

It's bad enough that the United States is losing its monopoly on drones, stealth technology, and advanced electronic warfare gear. But what makes matters worse is that America is also beginning to lose its edge on a particularly deadly and effective weapon, according to a new U.S. Air Force report: long-range 'land attack' cruise missiles.⁵

The proliferation of these missiles promises to stimulate a costly competition in counter-measures.

Second, in a time of economic crisis in which defense spending is being severely cut by most NATO allies, when only a few allies have been able to meet the defense budget goal of 2 percent of GDP, what priority will be given to the future development of these weapons? This question may be of grave concern for NATO, due to the pressures to eliminate certain national capabilities of specific allies. As of 2011, only five NATO allies were able to meet the 2 percent of GDP threshold: Albania (2.03), France (2.05), Greece (3.04), the United Kingdom (2.71), and the United States (4.68%).⁶

This thesis investigates the hypothesis that the NATO allies have relied to a significant degree on U.S.-built long-range precision-strike cruise missiles in their major interventions since 1995. It proposes to investigate this hypothesis by examining the characteristics of these missiles and the purposes that they have

⁵John Reed, "Cruise Missiles: Everyone's Building Them," FP National Security, last accessed August 21, 2013, http://killerapps.foreignpolicy.com/posts/2013/07/11/cruise_missiles_everyones_building_them?wp_login_redirect=0.

⁶Kori Schake, "US Retrenchment is Right and Overdue," in Tomas Valasek, ed. *All Alone? What US Retrenchment Means for Europe and NATO* (London: Centre for European Reform, 2012), 8.

served in major interventions involving NATO allies. The thesis will then analyze the implications of the dependence of the NATO allies on these U.S.-built missiles. The analysis will examine the financial constraints affecting Allied defense spending and the ability of the allies to afford such missiles. This may affect the quantity of such missiles procured by the United Kingdom, the only non-U.S. NATO ally armed with TLAMs. Financial constraints may also affect the ability of other NATO allies to buy such missiles from the United States or to develop and produce such missiles themselves. The dependence on U.S. capabilities and technology may be all the more significant for the NATO allies in a context in which the United States has declared an intention to “pivot” to the Asia-Pacific region.

D. LITERATURE REVIEW

Since 1949, the North Atlantic Treaty Organization (NATO) has provided security and freedom for its member countries. Throughout its post-Cold War history (that is, since 1989–1991), NATO has had distinct advantages in military technology when compared to its adversaries. In its 1995 intervention in the Bosnia conflict, Operation Deliberate Force, NATO took advantage of one particular advance in military technology: precision-guided munitions (PGMs). For NATO, PGMs have provided an instrumental capability for three crucial strike operations: Deliberate Force in 1995, Allied Force in 1999, and Unified Protector in 2011. Though numerous scholars have written on various aspects of these operations, this literature review will first focus on PGMs. In addition, the literature review will take into account the fact that the NATO Alliance is facing fiscal austerity and severe cuts in defense spending, which will influence its future capabilities. Finally, this literature review will consider the three NATO operations listed above.

1. Precision-Guided Munitions

In *The Future of War: Power, Technology, and American World Dominance in the 21st Century*, George and Meredith Friedman make several

bold assertions in regard to the relationship between advanced technology (specifically PGMs) and potential warfare throughout the twenty-first century. By analyzing the transition from David's sling (used to defeat Goliath) to the employment of PGMs, the authors provide critical facts and argue that future conflicts will be revolutionized due to advanced technology. The book is written only with respect to the United States; however, the revolution in weaponry is changing the nature of warfare worldwide. In respect to NATO, which can be seen as a U.S.-led Alliance, two long-range PGMs, the Tomahawk Land Attack Missile and the Air Launched Cruise Missile/Conventional Air Launched Cruise Missile, will probably continue to contribute to the success of potential NATO strike operations, as with previous ones. These missiles, in conjunction with other capabilities, enable NATO allies to achieve battlespace dominance, project power, and gain air superiority. The employment of "nine thousand bombs" to destroy a given target is now being supplanted by "one or two bombs" in today's conflicts.⁷ As stated by the Friedmans,

Precision-guided munitions made possible an economy of force never before seen in an air war. Where hundreds or thousands of bombs had been necessary to destroy a given target in the past, a small handful would now suffice. Where dozens or hundreds of aircraft would have been necessary to carry out attacks in the past, only two or three were now necessary.⁸

Conceivably, as envisaged by the Friedmans in 1998, the age of ballistics is slowly drawing to an end, and the age of PGMs is with us now. The assertion made by the authors throughout the book, that PGMs will be the key factor in future conflicts, is reasonable. However, the authors fail to account for two major constraints on the future utility of PGMs. First, the financial limitations of the United States and other nations need to be addressed. Second, as PGM technology continues to advance, so do enemy counter-measures. In order to

⁷George Friedman and Meredith Friedman, *The Future of War: Power, Technology and American World Dominance in the Twenty-First Century* (New York: St. Martin's Griffin, 1998), 269.

⁸*Ibid.*, 278.

critically analyze the future relevance of these strategic weapons, one must address the economic situation and potential enemy counter-measures. Without question, the employment of such weaponry has afforded NATO the opportunity to be more efficient than in previous operations; however, the future utility of PGMs may be constrained by financial and political factors as well as enemy counter-measures. In an era of mounting costs for advanced technology, these factors increase the challenges of using it.

In *Weapons of Choice: The Development of Precision Guided Munitions*, Paul G. Gillespie analyzes the history and effects of precision-guided munitions since World War I. According to Gillespie, the analyses and insights provided by this significant body of work show overwhelming evidence that precision-guided munitions, “capable of producing far-reaching effects,” have transformed the way wars are conducted today and will be waged in the future.⁹ Gillespie contends that, “while a number of technologies were developed in the next half-century [that is, the next half century following World War II] to increase air power’s effectiveness, including improved cluster bombs, proximity fuses, penetrating warheads, napalm and other incendiaries, and stealth technology, nothing has revolutionized modern warfare in quite the same way as precision guidance.”¹⁰ Moreover, he explains how the fabric of technology is built around social processes (including ethics and values), and how it would be “misleading to present it as the achievement of individual genius.”¹¹ Gillespie’s book is concise and well written. He devotes considerable attention to the impact that precision-guided munitions have had—and promise to have—on national security and military strategy worldwide.

However, there are three major weaknesses in Gillespie’s work. First, he raises several questions and concerns, but offers little insight into the answers.

⁹Paul G. Gillespie, *Weapons of Choice: The Development of Precision Guided Munitions* (Tuscaloosa: The University of Alabama Press, 2006), 2.

¹⁰*Ibid.*

¹¹*Ibid.*, 5.

Second, his work sedulously focuses on one class of weapon, conventional bombs. He neglects other types of precision-guided munitions, such as long-range cruise missiles. Third, Gillespie's book has to be read with caution, as some of his observations are incorrect. For example, he describes the modern-day cruise missile as lacking "flexibility in terms of in-flight retargeting ... capability."¹² It is surprising to find this statement in a book published in 2006 because even then it was publicly known that the Tomahawk Land Attack Missile (Echo) possessed this capability.

Kenneth P. Werrell covers the evolution of a specific precision-guided munition in *The Evolution of the Cruise Missile*. Though this work is somewhat outdated (1985), it was one of the first studies to examine the evolution of these strategic weapons. It can be compared to the book edited by Richard Betts, *Cruise Missiles: Technology, Strategy, Politics*, and the book by Ronald Huisken, *The Origin of the Strategic Cruise Missile*, both published in 1981.¹³ Werrell analyzes the significant technological advances that have accrued over the last century for cruise missiles, and provides critical assessments. Werrell classes cruise missiles as one of the greatest technological advances since gunpowder, the "device ... likely to revolutionize modern warfare," or "the gun of the future."¹⁴ Additionally, this work addresses the political and "intraservice and interservice rivalry," which surfaced during the Second World War in regard to the cruise missile.¹⁵ Werrell implies that this rivalry was a major factor complicating the development of this strategic weapon. Werrell's work is concise and clear, and provides analytical depth and insight on the historical record of cruise missiles.

¹²Ibid., 6.

¹³Richard K. Betts, ed., *Cruise Missiles: Technology, Strategy, Politics* (Washington, DC: The Brookings Institution, 1981); and Ronald Huisken, *The Origin of the Strategic Cruise Missile* (New York: Praeger Publishers, 1981).

¹⁴Kenneth P. Werrell, *The Evolution of the Cruise Missile* (Maxwell Air Force Base: Air University Press, 1985), 2.

¹⁵Ibid., 79.

Nonetheless, technology has continued to advance since its publication, and the work does not fully cover today's weaponry. Werrell offered the following prediction:

Technology for the future generation cruise missile is also well advanced. At this time the key areas appear to be electronics, engines, and fuels. These promise to produce reliable and markedly improved performance in short order. Therefore, these next generation cruise missiles should maintain the lead the present ones enjoy over current enemy air defenses. This prospect of continued technological superiority ensures that the cruise missile will be vital to American security in the foreseeable future.¹⁶

The work is better suited for the novice interested in the basic characteristics and history of this weapon, and not so much for the experienced reader, as it lacks the details necessary in an account for specialists.

Werrell's *Chasing the Silver Bullet: U.S. Air Force Weapons Development from Vietnam to Desert Storm* analyzes the development of Air Force technology from the mid-1960s through the early 1990s. In examining this complex and often controversial subject, Werrell discusses many aspects of Air Force technology. Drawing on his Air Force service, Werrell provides an exceptional personal perspective on the development and success of Air Force weaponry, ranging from the F-105 fighter-bomber to precision-guided munitions. He describes the evolution of this weaponry as being "more than a function of the rich financial, industrial, and intellectual resources of American society," and attributes its success to those "dedicated and talented individuals in industry and the military [who] were responsible for the technology that emerged to help make America the undisputed air power and military power in the world."¹⁷

Additionally, Werrell shows how innovation has changed the content of warfare, declaring that "For many, technology is the panacea, America's trump

¹⁶Ibid., 212.

¹⁷Kenneth P. Werrell, *Chasing the Silver Bullet: U.S. Air Force Weapons Development from Vietnam to Desert Storm* (Washington, DC: Smithsonian Books, 2003), 2.

card.”¹⁸ Werrell remains unbiased throughout his work, pointing out how war consists of much more than technology, and how technology alone cannot win wars. As the technology of today’s adversaries has the potential of being fairly equivalent to U.S. technology, one should not overemphasize the importance of technology. Though seventy percent of his work relates to aircraft, Werrell provides an exceptionally useful overview of U.S. Air Force technology following World War II. Werrell’s wealth of knowledge not only sheds considerable light on the weapons themselves, but also on the influence of political involvement.

2. Operation Deliberate Force

In *Deliberate Force: NATO’s First Extended Air Operation*, David L. Dittmer and Stephen P. Dawkins provide a chronological account of the air operations in Operation Deliberate Force (ODF) and address the crucial elements (such as a revised understanding of command and control between the UN and NATO, and superior leadership) which brought success to the Alliance in ODF. The authors suggest that the trigger for NATO air operations resulted from “a series of brutal offensives by the Bosnian Serb Army against the UN safe areas,” including Sarajevo.¹⁹ The authors note that the Sarajevo offensives were “portrayed in color on CNN worldwide,” and hold that “the compelling force of world public opinion” required the use of decisive military force by NATO.²⁰ Considered NATO’s first extended air operation, Deliberate Force involved the decisive use of airpower, and precision airstrikes played a critical element in support of Allied diplomacy.

Moreover, Dittmer and Dawkins were analytical in their approach toward the dilemmas presented to both the political leaders and the coalition forces (including those in the UN and NATO), as each party regarded the operational employment of airpower differently. The authors emphasize the airpower

¹⁸Ibid.

¹⁹David L. Dittmer and Stephen P. Dawkins, *Deliberate Force: NATO’s First Extended Air Operation: The View from AFSOUTH* (Alexandria: Center for Naval Analyses, 1998), 2.

²⁰Ibid.

involved in ODF, and consequently at times the reader seems to receive the message that airpower was the only decisive factor in ODF, which would be a somewhat misleading impression. Airpower demonstrated a certain degree of political will, but other key factors of importance, such as economic sanctions and the role of the political arena, had an imposing influence. As one of the first military operations undertaken by NATO, in which a “shift from a UN military *peacekeeping* operation to a NATO *peace-enforcement* operation” was witnessed, a number of key factors were relevant throughout this operation.²¹

Robert C. Owen and his co-authors captured the planning, execution, and results of Operation Deliberate Force in *Deliberate Force: A Case Study in Effective Air Campaigning*. This work provides future leaders an in depth understanding of the use of airpower and the significance it will provide for future foreign policy. By thoroughly examining key geopolitical, sociological, diplomatic, technological, and operational factors, the authors showed that the utilization of airpower delivered what it promised in ODF. Airpower served as a “decisive element in bringing a new period of peace to Bosnia—quickly, cleanly, and at a minimal cost in blood and treasure to the intervening states and, indeed, to the Bosnian Serbs.”²² Additionally, this fundamental study illuminates the importance of the political-military environment for future operations. The authors hold that one foundation for success resides in the political-military structure between the UN and NATO. Despite the somewhat “tenuous” relationship between the UN and NATO, the operation “highlighted the ability of separate political and military organizations to work together.”²³ This study concluded that the successful use of airpower would be central to the relationship between political authorities and the military.

Michael O. Beale addresses the political and historical context of Operation Deny Flight and Operation Deliberate Force in *Bombs Over Bosnia*:

²¹Ibid., 47. Italics in the original.

²²Owen, *Deliberate Force: A Case Study in Effective Air Campaigning*, 515.

²³Ibid., 60.

The Role of Airpower in Bosnia-Herzegovina.²⁴ While Beale acknowledges the pivotal role that airpower played within the broader Yugoslav War, he is quick to point out that it was not the most decisive factor, nor did it bring an end to the war itself. According to Beale, “Factors equal in importance to airpower were the role international and domestic politics played, the difficulty of forging an acceptable military option agreeable to both the UN and NATO, economic sanctions against the former Yugoslavia, and the growing military superiority of the Bosnian/Croat Confederation.”²⁵ Beale deems economic sanctions the most decisive factor in the Yugoslav War, due to the immeasurable pressures on Milosevic and his regime. Beale offers insights about both Operation Deny Flight and Operation Deliberate Force. He covers the many advantages of airpower, as well as its limitations. He concludes that “airpower without political consensus in a hostile environment can be more of a liability than an asset.”²⁶ Thanks largely to developments in the economic and political arenas, Operation Deny Flight and Operation Deliberate Force were conducted in a favorable environment for airpower to be successful.

3. Operation Allied Force

In *NATO’s Air War for Kosovo: A Strategic and Operational Assessment*, Benjamin S. Lambeth analyzes and summarizes the key events and lessons learned from Operation Allied Force (OAF). By analyzing NATO’s 78-day air war, Lambeth captured the essence of the operation’s strengths and weaknesses. As Lambeth observed, OAF “represented the first extended use of military force by NATO, as well as the first major combat operation conducted for humanitarian objectives against a state committing atrocities within its own borders.”²⁷ He wrote, “NATO’s leaders remained blind to the fact that air power’s very strengths

²⁴Michael O. Beale, *Bombs Over Bosnia: The Role of Airpower in Bosnia-Herzegovina* (Maxwell Air Force Base: Air University Press, 1997).

²⁵*Ibid.*, 43.

²⁶*Ibid.*, 47.

²⁷Benjamin S. Lambeth, *NATO’s Air War for Kosovo: A Strategic and Operational Assessment* (Santa Monica: RAND Corporation, 2001), 219.

can become weaknesses if the air weapon is used in a way that undermines its credibility.”²⁸ He emphasized this point by describing the persistent disagreements among the leaders of NATO, including France and the United States, and their contradictory views on how allied air power should be utilized against the forces of Slobodan Milosevic, then president of the Federal Republic of Yugoslavia. Furthermore, he noted this discord among the Alliance’s leaders led to its failure to capitalize on NATO’s air power potential.²⁹ Additionally, Lambeth and many other scholars have cautioned those who believe that Milosevic was bombed into submission by this 78-day air war, and have pointed out that other contributing factors should be taken into account, such as the threat of an invasion by ground troops.³⁰ A senior research associate for the RAND Corporation, Lambeth provides an exceptional body of knowledge in regard to the airpower used in Kosovo. His report raises several questions, with implications for the continuing debate over the role of airpower in Operation Allied Force.

The Department of Defense’s *Kosovo/Operation Allied Force After-Action Report to the Congress* examines with a critical eye the overwhelming success and the many minor shortcomings of Operation Allied Force. In addition to highlighting the important lessons learned, the report identifies the cornerstone of OAF, NATO’s precision strike capability. The report describes OAF as “undoubtedly the most precise air and missile combat in [NATO’s] history,” and implies that, due to the success of PGMs, future operations will be similar.³¹ The

²⁸Ibid., 231.

²⁹Ibid., 185.

³⁰Daniel L. Byman and Matthew C. Waxman, “Kosovo and the Great Air Power Debate,” *International Security* 24, no. 4 (Spring 2000); Anthony H. Cordesman, *The Lessons and Non-Lessons of the Air and Missile Campaign in Kosovo* (Westport: Praeger, 2001); Ivo H. Daalder and Michael E. O’Hanlon, *Winning Ugly: NATO’s War to Save Kosovo* (Washington, DC: The Brookings Institution, 2000); Benjamin S. Lambeth, *NATO’s Air War for Kosovo* (Santa Monica: RAND Corporation, 2001); and Wesley K. Clark, *Waging Modern War: Bosnia, Kosovo, and the Future of Combat* (New York: Public Affairs, 2001).

³¹*Kosovo/Operation Allied Force After-Action Report to Congress* (Washington, DC: U.S. Department of Defense, 31 January 2000), xxiii.

report highlights the unprecedented advantages of employing Tomahawks and other PGMs as strategic weapons: minimizing the loss of personnel and decreasing the chances of damaging unintended targets. The report also acknowledges the shortcomings of these weapons: they are not as effective against moving targets as against fixed targets, and they are also vulnerable to jamming. Despite the overwhelming success of OAF, the report revealed a major disparity within the Alliance, the capabilities gap between the United States and the other allies. In short, as NATO continues to operate in its crisis management role, the capabilities gap within the Alliance will have a serious effect upon its capacity to deal with twenty-first century threats. In light of declining defense budgets, these disparities may even widen.

In *Waging Modern War: Bosnia, Kosovo, and the Future of Combat*, retired General Wesley K. Clark, former Supreme Allied Commander Europe as well as the U.S. European Command Commander, provides a personal perspective on Operation Allied Force. Due to his personal involvement, Clark offers a unique insight into the fundamental differences (political involvement, command and control, etc.) among Alliance members while conducting OAF. According to Clark, “The United States was increasingly committed to the idea of strategic strikes, going after the heart of Milosevic’s power. The Europeans, or at least the French and a few others, were more interested in limiting the strikes to Kosovo.”³² These fundamental differences developed into a “dichotomy between political aims and military means.”³³ Because Clark heavily emphasizes the political side of OAF, he does not provide a thorough analysis of the operation itself. Nonetheless, Clark’s unique personal perspective sheds considerable light on issues that continue to face NATO, and that could be seen in Operation Unified Protector in Libya in 2011.

³²Wesley K. Clark, *Waging Modern War: Bosnia, Kosovo, and the Future of Combat* (New York: Public Affairs, 2001), 237.

³³*Ibid.*, 244.

In *Disjointed War: Military Operations in Kosovo, 1999*, Bruce R. Naradulli and his co-authors examine a host of issues surrounding Operation Allied Force. Naradulli and his co-authors hold that these issues “caused confusion, probably made the operation less effective than it could have been, and possibly delayed victory.”³⁴ Naradulli and his co-authors make clear that decision-makers need to evaluate the issues that arose during OAF, and also to consider these issues as part of an ongoing effort to enhance NATO for future operations. Additionally, the lack of political and military cohesion visible in OAF continues to highlight the disparities in capabilities between the United States and other NATO members. The authors stress that future operations are “likely to be characterized by conflicts in which political imperatives call for the United States to act as part of a larger political-military alliance or coalition.”³⁵ Nonetheless, despite the many divisive pressures faced by the NATO allies, their determination and ability afforded a clear victory in OAF. As acknowledged by the authors, much material, specifically that concerning tactics and weapons performance, was omitted from this book. This important information might have enhanced understanding of the role that airpower played in OAF.

Stephen T. Hosmer, in *The Conflict Over Kosovo: Why Milosevic Decided to Settle When He Did*, weighs and analyzes the various reasons why Milosevic initially refused to concede to NATO’s demands and why he eventually chose not to continue the war. Hosmer argues that the use of airpower created a political climate conducive to major concessions, caused worry in the regime over damage to “dual-use” infrastructures, and deepened fear of unconstrained bombing on Serbia if NATO’s terms were rejected. In Hosmer’s view, these factors “appear to have shaped Milosevic’s decisionmaking” in conceding in early June of 1999.³⁶

³⁴Bruce R. Naradulli et al., *Disjointed War: Military Operations in Kosovo, 1999* (Santa Monica: RAND Corporation, 2002), xiii.

³⁵*Ibid.*, 121.

³⁶Stephen T. Hosmer, *The Conflict Over Kosovo: Why Milosevic Decided to Settle When He Did* (Santa Monica, CA: RAND Corporation, 2001), 1, 65.

The analysis and insights suggested by Hosmer provide two valuable lessons for NATO and the United States in regard to the use of air power in future conflicts. First, the NATO allies must improve weapon systems that are capable of attacking dispersed and hidden forces. Second, the NATO allies should preserve the capability of attacking dual-use targets.³⁷ It can be assumed, as predicted by Hosner, that future conflicts (as in Operation Unified Protector) will be conducted with similar operational objectives. Understanding these lessons is critical for operational success in future conflicts.

4. Operation Unified Protector

Erica D. Borghard and Costantino Pischedda, in “Allies and Airpower in Libya,” explain in detail the way in which the “Afghan model (synergy of precision airstrikes and local allies fighting on the ground) “ was a success in Operation Unified Protector (OUP), and may serve as a template for future operations.³⁸ Additionally, Borghard and Pischedda provide a telling example of how Muammar Qaddafi’s regime was overthrown without the assistance of NATO land forces. In their analysis, the utilization of both airpower and local allies was systematically stressed. In view of the effective relationship between airpower and local allies in OUP, Borghard and Pischedda suggest that future NATO operations will rely heavily on air power, and look to local allies for ground support.

With conclusions similar to those of the previous authors, Ivo H. Daalder and James G. Stavridis, in “NATO’s Victory in Libya: The Right Way to Run an Intervention,” hail Operation Unified Protector as a successful intervention, a blueprint for future operations. Daalder and Stavridis argue that OUP demonstrated the Alliance’s effectiveness; nonetheless, they observe, the

³⁷Ibid., 132–133.

³⁸Erica D. Borghard and Costantino Pischedda, “Allies and Airpower in Libya,” *Parameters* XLIII (Spring 2012), 63.

challenges in both conception and execution need to be addressed.³⁹ The authors hold that NATO faced two major challenges, the heavy reliance on the United States and the shortcomings in political unity within the Alliance. If the allies fail to meet these challenges, given the context of shrinking defense spending, “NATO may not be able to replicate its success in Libya in another decade.”⁴⁰ Deep-rooted challenges (including excessive reliance on the United States and capability gaps within the Alliance) have affected NATO since its inception.

Unlike the two previous works (which support the utilization of airpower and local ground troops), in “Libya’s Lessons: The Air Campaign,” Douglas Barrie argues against the reliance on airpower and local ground troops. Barrie acknowledges the vital role that air power played in OUP. In his view, “such operations, however, where air power is used to support local boots on the ground, should not be the default model for future interventions.”⁴¹ Additionally, Barrie points out a parallel between the length of the operation and the reduction of weapon inventories, specifically precision-guided munitions. Barrie provides adequate information to support his judgments. He nonetheless falls short of persuading the reader that NATO’s involvement in future operations will not mirror the pattern of Operation Unified Protector. The economic crisis—and constrained defense budgets—will further promote the utilization of these critical capabilities (airpower and the support of local ground forces), as military deficiencies (such as aerial refueling and intelligence, surveillance, and reconnaissance capabilities) will continue to be significant.

In their monograph, *Winning in Libya: By Design or Default?*, Michael W. Kometer and Stephen E. Wright raise a controversial question. Was the United Nations Security Council (UNSC) mandate, which authorized the use of “all

³⁹Ivo H. Daalder and James G. Stavridis, “NATO’s Victory in Libya: The Right Way to Run an Intervention,” *Foreign Affairs* 91, no. 2 (March -April 2012), 3.

⁴⁰*Ibid.*, 7.

⁴¹Douglas Barrie, “Libya’s Lessons: The Air Campaign,” *Survival* 54, no. 6 (December 2012–January 2013), 64.

necessary measures” to protect citizens from armed attacks, coupled with the implementation of an arms embargo and a no-fly zone, exceeded with the capture and killing of Qaddafi?⁴² In a comprehensive study, the authors demonstrate how unclear UN objectives on end states led to “a lack of clear political guidance at the strategic level, which often translated into somewhat inconsistent military planning at the operational level.”⁴³ Yet, despite these circumstances, the authors emphasize that OUP was successful due to the impact of airpower. Airpower aided NATO in ensuring the achievement of the UNSC mandate by preventing a humanitarian catastrophe, and thus protecting the citizens of Libya. Kometer and Wright hold that “the 2011 civil war in Libya provides a case study that delivers many perspectives and lessons for strategists and planners, especially for the air component.”⁴⁴

At first sight, the result of Operation Unified Protector suggests that future operations will be fought in the same fashion. However, in the collection of papers entitled *Short War, Long Shadow: The Political and Military Legacies of the 2011 Libya Campaign*, Adrian Johnson and Saqeb Mueen argue that OUP will be remembered more as “a one-off case than as a model” for future interventions.⁴⁵ The critical insights offered by this collection of papers provide grounds to believe that future operations will not mirror those of OUP, regardless of its successful outcome. According to Michael Clarke, OUP “could easily have been a politico-military embarrassment to Britain and its allies.”⁴⁶ The analyses provided by the contributors to this collection highlight critical problems, including

⁴²Michael W. Kometer and Stephen E. Wright, *Winning in Libya: By Design or Default?* Focus Stratégique no. 41 (Paris: Laboratoire de Recherche sur la Défense, Institut Français des Relations Internationales, January 2013), 13.

⁴³*Ibid.*, 5.

⁴⁴*Ibid.*, 39.

⁴⁵Adrian Johnson and Saqeb Mueen, eds., “Introduction,” *Short War, Long Shadow: The Political and Military Legacies of the 2011 Libya Campaign* (London: Royal United Services Institute for Defence and Security Studies, 2012), 5.

⁴⁶Michael Clarke, “The Making of Britain’s Libya Strategy,” in Adrian Johnson and Saqeb Mueen, eds., “Introduction,” *Short War, Long Shadow: The Political and Military Legacies of the 2011 Libya Campaign* (London: Royal United Services Institute for Defence and Security Studies, 2012), 12.

the process by which strategic decisions were made within the Alliance, capability gaps within the Alliance, and the divisions among the allies. These divisions were apparent with Germany's and Turkey's initial decisions not to participate in the operation. (Turkey changed course and participated in OUP.) In sum, the collection of papers offers a broad overview of OUP. An operation originally intended to prevent a humanitarian disaster became the context of a controversial regime change.

E. METHODS AND SOURCES

This thesis will analyze the functions in NATO operations of PGMs, and explore the possible utility of these weapons in potential future NATO operations. The thesis will examine three strike operations in which these strategic weapons were used and the outcome of those operations:

- Operation Deliberate Force (Bosnia Campaign). On August 30, 1995, NATO initiated Operation Deliberate Force (an assertive air campaign), which relied on precision strikes against selected targets in Serb-held Bosnia and Herzegovina. Operation Deliberate Force could be considered the first large-scale mission that aided NATO in defining its new roles in crisis management and conflict prevention.
- Operation Allied Force (Kosovo Campaign). After the failure of diplomatic attempts to end the violence, repression, and violations of human rights ordered by the government of the Federal Republic of Yugoslavia (FRY) and its elected president, Slobodan Milosevic, on March 24, 1999, NATO launched Operation Allied Force, which included precision strikes against many high-priority targets in the FRY.
- Operation Unified Protector (Libya Campaign). On March 19, 2011, NATO forces (from France, the United Kingdom, and the United States) launched a campaign of air and cruise missile strikes against targets in Libya, in support of United Nations Security Council Resolutions 1970 and 1973. This would become the biggest intervention in an Arab country since the 2003 Iraq War.

The aforementioned operations will be evaluated because they were the only operations in which long-range PGMs were used. Moreover, this thesis will rely

heavily on after-action reviews and primary sources, as well as scholarly books, military studies, and academic journals.

F. THESIS OVERVIEW

This thesis analyzes the functions in NATO operations of long-range PGMs, and explores the possible future utility of these weapons for NATO operations in the ever-changing security environment. The thesis is organized into six chapters. Chapter I presents the major research question and highlights the importance of this study, while discussing the various sources used. Chapter II studies the evolution of the cruise missile and discusses in detail one particular cruise missile, the Tomahawk Land Attack Missile. Chapter III focuses on three defining NATO operations: Operation Deliberate Force, Operation Allied Force, and Operation Unified Protector. These cases are evaluated because they provide telling examples of why precision-guided munitions have become a weapon of choice for the Alliance in potential future operations. Chapter IV focuses on the operational capabilities gap between the United States and its NATO allies, and its possible significance for future operations. Chapter V shows how the operational success of cruise missiles has attracted attention around the world, and discusses the challenges it presents in the foreseeable future. Lastly, Chapter VI offers conclusions and recommendations for NATO concerning the future utility of cruise missiles.

THIS PAGE INTENTIONALLY LEFT BLANK

II. LONG-RANGE PRECISION-STRIKE CRUISE MISSILES IN NATO OPERATIONS

A. DEFINITION OF A CRUISE MISSILE

What is a cruise missile? There are differing views about the true definition of a cruise missile. However, in simple terms, a cruise missile “is simply a miniature, self-guided, unmanned, armed, one-way aircraft, which is dependent on air for lift and as a source of oxygen.”⁴⁷ According to an official definition, “a cruise missile is a guided missile, the major portion of whose flight path to its target is conducted at approximately constant velocity; [it] depends on the dynamic reaction of air for lift and upon propulsion forces to balance drag.”⁴⁸ This definition includes unmanned aerial vehicles, or drones, as well as altered vehicles capable of carrying a warhead on a single flight. For decades, cruise missiles have been seen as the weapon of choice for not only NATO, but other military organizations as well.

Cruise missiles are small and able to fly close to the ground. This reduces their radar cross-section and allows them to hide behind hills and the curvature of the earth, making them much harder to detect and defeat. As stated by Ronald Huisken, “Because it is subsonic and cannot do anything but what it is programmed to do, the survivability of the cruise missile depends critically on it remaining undetected until it is too late for the defenses to react.”⁴⁹ This capability has on some occasions enabled U.S. and NATO forces to gain complete domination of the battle space, which is a critical component for operational success. Cruise missiles have therefore revolutionized modern warfare.

⁴⁷Kenneth P. Werrell, “The Weapon the Military Did Not Want: The Modern Strategic Cruise Missile,” *The Journal of Military History* 53, no.4 (Oct., 1989), 420.

⁴⁸Joint Pub 1-02, *Department of Defense Dictionary of Military and Associated Terms* 1998, 118.

⁴⁹Ronald Huisken, *The Origin of the Strategic Cruise Missile* (New York: Praeger Publishers, 1981), 5.

B. THE ORIGINS OF CRUISE MISSILES

While weapons come and go in the military, history provides examples of classes of weapons having both a dramatic and a lasting impact upon the conduct of warfare.⁵⁰

Since their inception, cruise missiles have been hailed as one of the greatest technological advances since gunpowder. As stated in *The Evolution of the Cruise Missile*, by Kenneth P. Werrell, “Except for gunpowder and [the] atomic bomb, no weapon has threatened a greater effect on war and peace than the cruise missile.”⁵¹ This sophisticated weapon has revolutionized the conduct of modern warfare.

The concept of cruise missiles (known as “flying bombs” and “aerial torpedos” in their earlier life) can be traced back to the first World War, in which attempts were made by two inventors, Peter C. Hewitt (inventor of the mercury vapor lamp) and Elmer A. Sperry (of Sperry Gyroscope Company), to pioneer such devices for inclusion in the U.S. military arsenal.⁵² Thanks to both inventors, great promise would be demonstrated in the design and testing of these devices in the summer of 1916. Nonetheless, despite this seemingly great promise, there were numerous failures, and the cruise missile for the United States would not see life before Germany’s employment of the V-1 (the Vergeltungswaffen Eins) cruise missile in World War II.

On June 13, 1944, it was estimated that Germany had employed over 10,000 V-1 cruise missiles against the United Kingdom in World War II.⁵³ According to Werrell, “The V-1 ... ushered in a new type of warfare consisting of remote bombing of cities by pilotless weapons launched over a hundred miles away through all kinds of weather, day and night.”⁵⁴ Moreover, the German class

⁵⁰Werrell, *The Evolution of the Cruise Missile*, 1.

⁵¹Ibid., 2.

⁵²Werrell, *The Evolution of the Cruise Missile*, 7.

⁵³Huisken, *The Origin of the Strategic Cruise Missile*, 15.

⁵⁴Werrell, *The Evolution of the Cruise Missile*, 41.

of cruise missile featured a number of other advantages. First, it was fairly cheap to build, and it could therefore be available via mass production, as seen in World War II Germany. It was estimated that in all, Germany produced close to 30,000 “V” variant cruise missiles in World War II.⁵⁵ Moreover, due to their unique flight profile (high speed and low altitude approach), German cruise missiles were difficult to detect and intercept. Lastly, launch personnel were not put at risk. Conversely, the V-1 had a number of disadvantages. As Richard K. Betts has observed, “At first it was quite effective, but because the technology was crude—the V-1 was large and slow and flew at relatively high altitudes ... defenses were able to adapt and eventually destroyed the bulk of the missiles before they could reach their targets.”⁵⁶ It was estimated that over eighty percent of Germany’s cruise missiles were launched from ramps, with over twenty percent crashing at launch, and with adversaries shooting down over fifty percent of those remaining while in flight.⁵⁷

By the 1950s, building on the German concept, the United States quickly emulated and started several cruise missile programs. In an attempt to surmount the shortcomings of the V-1, the United States committed its efforts to the guidance and launching element of this weapon. With the help of recovered German V-1 parts, the United States was able to design a variety of cruise missiles that had great potential, including:

1. Navaho, a ramjet-propelled cruise missile that was a small, light-weight system, guided to its target by inertial guidance.
2. Snark, a cruise missile of intercontinental range that, by means of inertial guidance, could achieve a circular error probability (CEP) of under five nautical miles.

⁵⁵Ibid., 61.

⁵⁶Richard K. Betts, *Cruise Missiles and U.S. Policy* (Washington, DC: The Brookings Institution, 1982), 4.

⁵⁷Werrell, *The Evolution of the Cruise Missile*, 61.

3. Mace, a nuclear-armed subsonic cruise missile, which could fly to a range of 600 nautical miles by employing an early form of terrain correlation, map-matching.
4. Hounddog, another nuclear-armed air-to-surface cruise missile, designed as a bomber penetration aid.
5. Talos, an air-defense cruise missile.⁵⁸

Despite the vast improvements, however, these and other first-generation cruise missiles continued to present major weaknesses. As highlighted by Werrell, they “had continued problems of reliability, accuracy, and vulnerability and could not compete with ballistic missiles which had distinct advantages.”⁵⁹ Because these disadvantages outweighed the many advantages, the United States dedicated little effort to cruise missile technology throughout the 1960s, thereby postponing cruise missile development until the 1970s. As Werrell notes, “there were, to be sure, a number of small programs in both the Air Force and Navy working on cruise missile technology, but these were not intended to produce a strategic cruise missile.”⁶⁰

Not until the 1970s, owing in part to advancing technology in warheads (specifically nuclear), turbofan engines, fuels, materials, and terrain contour-matching (TERCOM) navigation systems, would the development of the modern cruise missile begin. As stated by Betts, “What transformed the neglected cruise missile into an important part of defense program was an uncoordinated evolution of technological innovations rather than a deliberate effort or an epochal breakthrough.”⁶¹ Advancing technology assisted in transforming the once large, unpredictable, and inaccurate cruise missiles of the past century into a new type of weapon that would have a dramatic and enduring effect on the

⁵⁸Robert L. Pfaltzgraff, Jr. and Jacquelyn K. Davis, *The Cruise Missile: Bargaining Chip or Defense Bargain?* (Washington, DC: Corporate Press Inc., 1977), 6.

⁵⁹Werrell, “The Weapon the Military Did Not Want,” 421.

⁶⁰*Ibid.*, 423.

⁶¹Betts, *Cruise Missiles and U.S. Policy*, 4.

conduct of warfare to the present day. With improvements in its performance, the cruise missile's prominence grew, and political factors became more relevant in the 1970s. Throughout the 1970s, support for the cruise missile intensified, as top officials for DOD, "especially Deputy Secretary of Defense William Clements, were enthusiastic about the weapon."⁶² This newfound attention to cruise missiles would merge the efforts of the United States Navy (USN) and United States Air Force (USAF). Due to the seemingly parallel programs of the two military services in cruise missile development, a designated joint system acquisition effort was formed, and became known as the Joint Cruise Missiles Project Office (Figure 1).

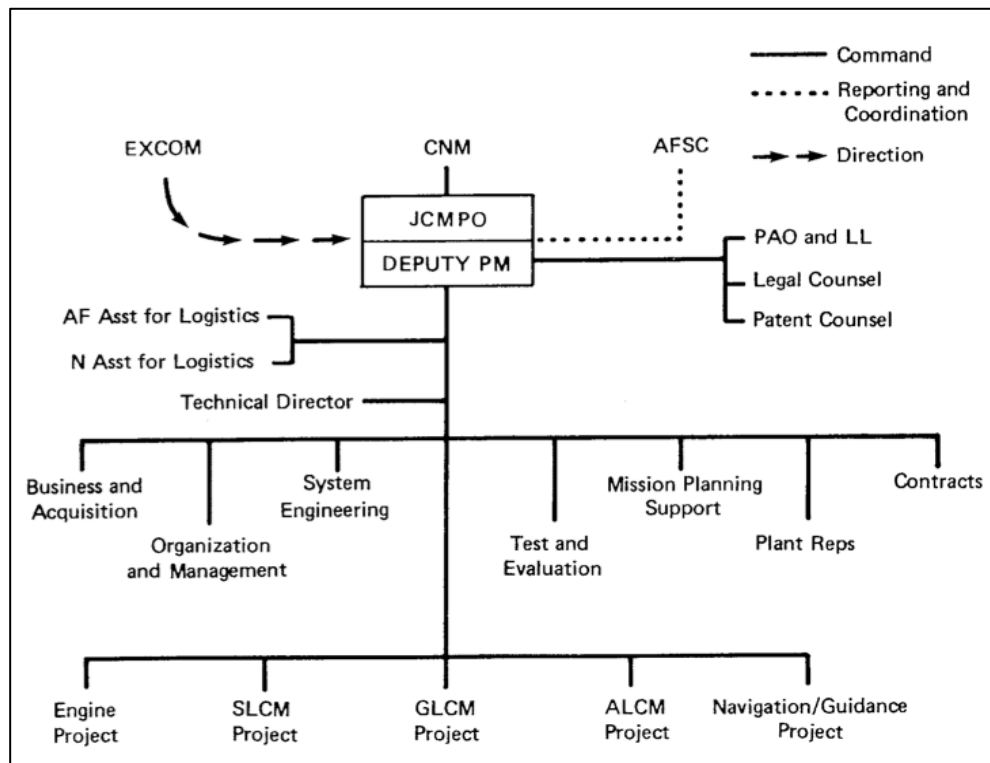

Figure 1. JCMPO Organizational Structure⁶³

⁶²Werrell, "The Weapon the Military Did Not Want," 424.

⁶³E. H. Conrow et al., *The Joint Cruise Missiles Project: An Acquisition History* (Santa Monica: RAND Corporation, 1982), 10.

Originally, to counter and deter Soviet aggression, the U.S. cruise missile program focused on the option of developing a submarine-launched nuclear weapon delivery vehicle. As highlighted by Betts, “The most obvious contribution of cruise missiles to the U.S. force posture is in essential equivalence” to that of the Soviet Union.⁶⁴ However, under the direction of the U.S. Department of Defense (DOD) in the early 1970s, the program would develop into a wider range of weapons and launch methods, in which the development of two long-range precision strike cruise missiles would come into fruition. This new joint venture directed the “Air Force to share its turbofan engine and high-energy fuel with the Navy, and the Navy to share [its] TERCOM with the Air Force,” leading to a common development program that is significant today.⁶⁵ This encouragement and promotion of technology sharing between the Air Force and the Navy would go on to foster a “full-scale engineering development [for] an air-launched, anti-surface, theater, nuclear” cruise missile.⁶⁶ Today, both the Air Force and the Navy continue to be heavily involved in cruise missile program management, and this joint partnership continues to enable the cruise missile to grow in significance as a potent weapon. The outcome of this partnership was significant in the development of two strategic weapons accessible for the NATO Alliance, Tomahawk Land Attack Missile and the Air Launched Cruise Missile/Conventional Air Launched Cruise Missile.

C. THE TOMAHAWK LAND ATTACK MISSILE

In several NATO precision strike operations, the Tomahawk Land Attack Missile (TLAM) was the weapon of choice (Figure 2). Since 1995, TLAMs have provided the Alliance a formidable tool against adversaries, as seen in three major operations—Operation Deliberate Force (ODF), Operation Allied Force (OAF), and Operation Unified Protector (OUP). Since the initial use of TLAMs in

⁶⁴Betts, *Cruise Missiles and U.S. Policy*, 12

⁶⁵*Ibid.*

⁶⁶Janes, “Tomahawk Land Attack Missile,” HIS, last accessed September 5, 2013, <https://janes.ihs.com.libproxy.nps.edu/Grid.aspx>.

ODF, approximately 435 TLAMs have been employed in NATO operations. Although only in the hands of the United States and the United Kingdom (which can launch only from Royal Navy submarines), this strategic weapon has provided NATO greater force projection capability, without putting Alliance personnel (aircrews and ground troops) at risk.⁶⁷ It is estimated that close to 3,500 Tomahawk missiles have been manufactured, whereas 2,000 have been employed in various operations.⁶⁸



Figure 2. Tomahawk Land Attack Missile⁶⁹

The development of the TLAM can be tracked back to the late 1960s, when it was originally devised as a submarine-launched weapon delivery vehicle. Not until 1972 would the development of TLAM lead to a surface-launched weapon delivery vehicle. The United States Navy made it a priority to have a

⁶⁷In 1995, an agreement between the U.S. and the U.K was reached regarding of the sale of Tomahawk missiles. By the signing of a Foreign Military Sales Agreement, the U.K. was allowed to purchase 65 Tomahawk missiles, making this the first sale of TLAMs to a foreign country.

⁶⁸Missile Threat, "Tomahawk Variants," A Project of the George C. Marshall and Claremont Institutes, last accessed on February 27, 2014, <http://missilethreat.com/missiles/tomahawk-variants/?country=united-states#united-states>.

⁶⁹Ibid.

“ship- and submarine-launch capability for attacking ships and land targets; primarily in the early days with nuclear warheads, to provide an additional survivable nuclear force.”⁷⁰ After years of development, the TLAM ultimately saw its first submarine-launch in 1979 and its first surface-launch in 1980. However, not until 1983 was the TLAM entered into service and deployed on its first naval platform (Los Angeles Class Fast-attack Submarine). Nevertheless, it would not experience its first operational use until the first Gulf War, in which 291 Tomahawks would be fired.⁷¹ Since then, the TLAM has been employed successfully in several precision strike operations, not only for the Alliance, but also in U.S.-led coalition operations as well (e.g., Operation Enduring Freedom).

Today, we commonly refer to the TLAM as a conventionally armed, long range, all-weather, subsonic, cruise missile capable of a low-profile, multi-segmented flight. Since its inception, this strategic weapon has gone through an assortment of variants. Originally, the TLAM consisted of the TLAM-N (RGM-109A), a nuclear warhead missile; and the TASM (RGM-109B), a conventional high explosive (HE) warhead anti-ship missile. Since then, three variants have been added to the Tomahawk family: the TLAM-C (RGM-109C), a conventional HE warhead missile; the TLAM-D (RGM-109D), a conventional submunition warhead missile; and lastly, the TLAM-E (RGM-109E), a conventional HE warhead missile. Today, the Tomahawk family consists of four variants: three conventional warheads and one nuclear warhead (Table 1). Depending on the variant, these strategic weapons possess the capability of traveling at speeds exceeding 500 knots (subsonic speed) between 700 nautical miles (NM) to 1,400 NM on a given mission.

⁷⁰Janes, “RGM/UGM-109 Tomahawk,” Jane’s Strategic Weapon System, last updated March 27, 2013.

⁷¹Ibid.

Block	Designation	IOC	Guidance	Warhead	Range
Block I	TLAM-N	1986	INS, TERCOM	Nuclear Warhead	1350 NM
Block III	TLAM-C	1994	INS, TERCOM, DSMAC, GPS	1,000 Pound Class Unitary Warhead	900 NM
Block III	TLAM-D	1994	INS, TERCOM, DSMAC, GPS	Conventional Submunitions Dispenser with Combined Effect	700 NM
Block IV	TLAM-E	2004	INS, TERCOM, DSMAC, GPS	1,000 Pound Class Unitary Warhead	1400 NM

Table 1. Current Tomahawk Land Attack Missiles⁷²

1. Tomahawk Land Attack Missile “A” Variant

The TLAM-N is the first and only nuclear-armed missile of the Tomahawk family (Figure 3). With a W80 nuclear warhead, the TLAM-N was designed “as another dimension to strengthen deterrence” against Soviet aggression during the Cold War era.⁷³ In the 2010 *Nuclear Posture Review Report*, the United States announced the retirement of the TLAM-N.⁷⁴

⁷²Janes, “RGM/UGM-109 Tomahawk;” Missile Threat, “Tomahawk Variants.”

⁷³Missile Threat, “Tomahawk Variants.”

⁷⁴Department of Defense, *Nuclear Posture Review Report* (Washington, DC: Department of Defense, April 2010), 46.

BGM/RGM-109A Tomahawk Land Attack Missile - Nuclear (TLAM-N)

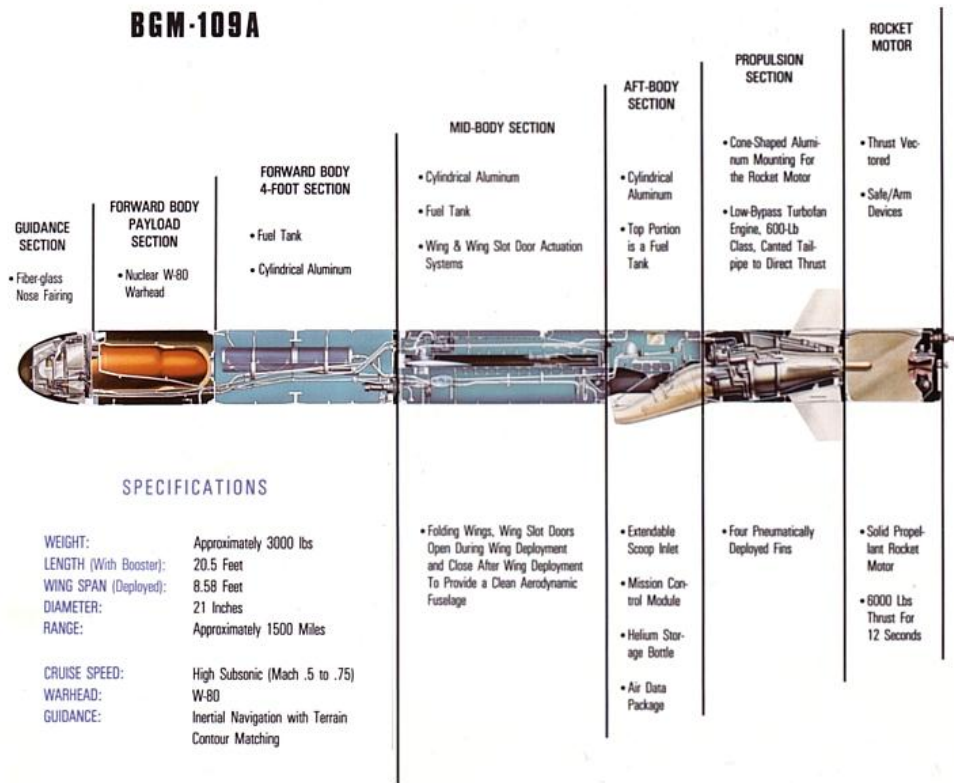

Figure 3. Tomahawk Land Attack Missile (TLAM-N)⁷⁵

2. Tomahawk Land Attack Missile “C” Variant

The TLAM-C (Figure 4) delivers a conventional 1,000-pound warhead designed to destroy or damage large hard targets (buildings, bases, etc.). It has the capability to travel up to 1,000 nautical miles. According to the website Missile Threat, the most recent upgrade was completed in 1986, and this introduced the digital scene matching area correlation (DSMAC) navigation system, designed for the TLAM-C and TLAM-D versions.⁷⁶ Today, the current

⁷⁵Carlo Kopp, “Tomahawk Cruise Missile Variants: BGM/RGM/AGM-109 Tomahawk/TASM/TLAM/GCLM/MRASM,” Technical Report APA-TR-2005-0702, last accessed February 14, 2014, <http://www.ousairpower.net/Tomahawk-Subtypes.html>.

⁷⁶Ibid.

TLAM-C inventory is being upgraded to possess Block IV capability, which will increase flexibility and operational control.⁷⁷

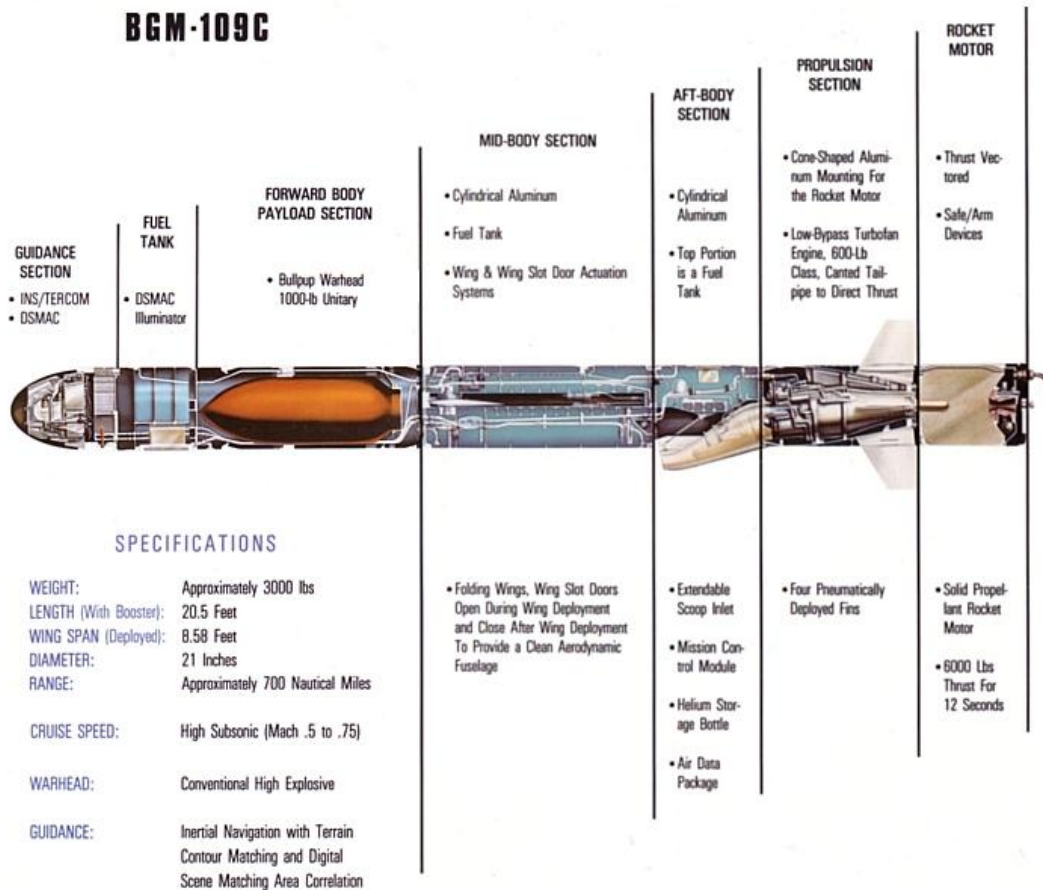

Figure 4. Tomahawk Land Attack Missile (TLAM-C)⁷⁸

3. Tomahawk Land Attack Missile “D” Variant

The TLAM-D (Figure 5) delivers Combined Effects Bomblets (CEB) submunitions (166 small armor piercing, fragmentation, and incendiary devices), and it has the capability of traveling up to 700 nautical miles. TLAM-D possesses the same guidance and accuracy capability as the TLAM-C, but differs in that it is

⁷⁷Janes, “RGM/UGM-109 Tomahawk;” Missile Threat, “Tomahawk Variants.”

⁷⁸Kopp, “Tomahawk Cruise Missile Variants.”

designed to strike softer targets (airfields, troop concentrations, air defenses, etc.). The TLAM-D is capable of flying horizontally, vertically, and overhead (to detonate directly over the target).⁷⁹ As with the TLAM-C, the TLAM-D inventory is being upgraded to possess Block IV capability.⁸⁰

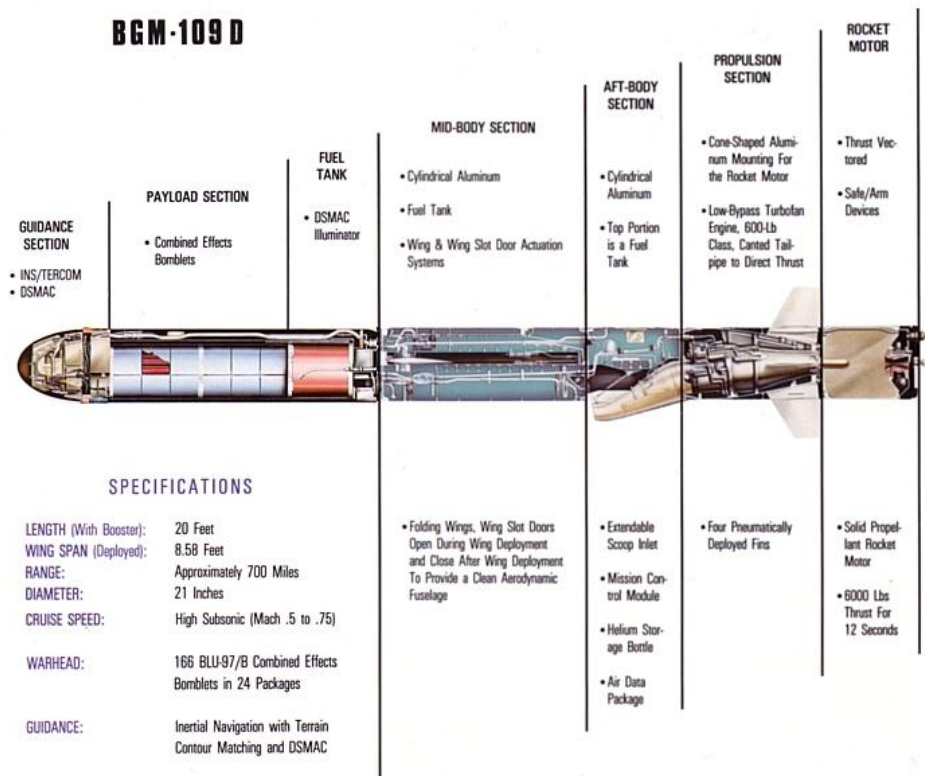

Figure 5. Tomahawk Land Attack Missile (TLAM-D)⁸¹

4. Tomahawk Land Attack Missile “E” Variant

The latest member of the Tomahawk family, the TLAM-E (Figure 6), also called the “tactical Tomahawk,” is an entirely redesigned missile.⁸² A much-improved variant, this missile possesses several unique capabilities superior to

⁷⁹Ibid.

⁸⁰Ibid.

⁸¹Kopp, “Tomahawk Cruise Missile Variants.”

⁸²Janes, “RGM/UGM-109 Tomahawk.”

those of the preceding variants: an increased range, an improved anti-jamming GPS system, and an enhanced battle damage assessment capacity. Moreover, unlike the TLAM-C and TLAM-D, which are “fire and forget” missiles, the TLAM-E is capable of changing targets and flight profiles after launch. Additionally, it has the capability of traveling up to 1,400 nautical miles.⁸³ The TLAM-E “was designed to maintain the high accuracy of previous versions, while increasing the flexibility and operational control.”⁸⁴ Currently, the TLAM-E is the only version being produced. For the remaining variants, it is reported that they have been or will be converted to block IV missiles.⁸⁵

⁸³Ibid.

⁸⁴Missile Threat, “Tomahawk Variants.”

⁸⁵Janes, “RGM/UGM-109 Tomahawk;” Missile Threat, “Tomahawk Variants.”

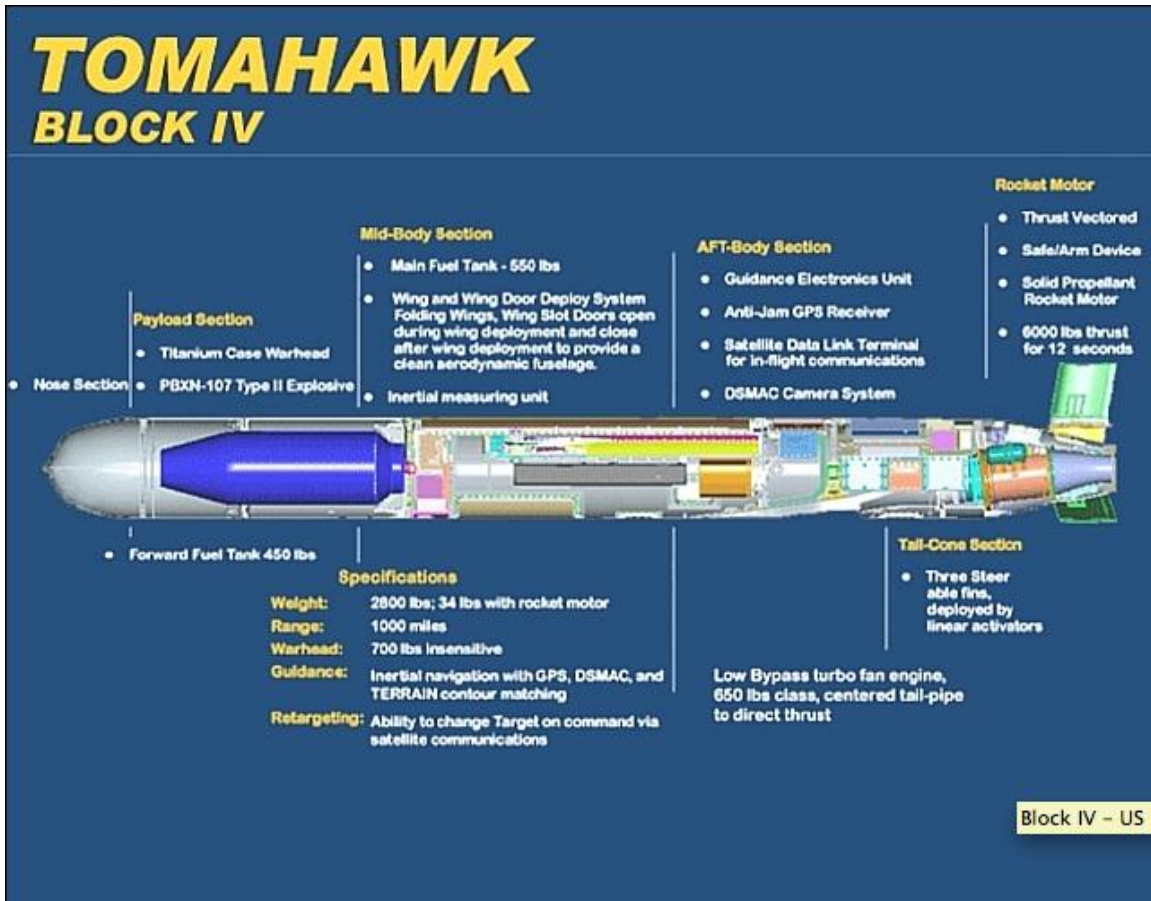

Figure 6. Tomahawk Land Attack Missile (TLAM-E)⁸⁶

⁸⁶Kopp, "Tomahawk Cruise Missile Variants."

III. NATO OPERATIONS IN WHICH CRUISE MISSILES HAVE BEEN EMPLOYED

A. OPERATION DELIBERATE FORCE (BOSNIA CAMPAIGN)

On August 30, 1995, following a series of mortar attacks by the Bosnian Serb Army (BSA) that resulted in a heavy loss of life (killing 38 civilians and injuring 85 others) in Sarajevo (an UN-designated safe area), NATO initiated Operation Deliberate Force (an extended air campaign) by launching precision strikes upon many high-priority targets in Serb-held Bosnia and Herzegovina. This operation served as a defining moment in NATO's history. It aided in clarifying NATO's new roles in not only peacekeeping, but also crisis management and conflict prevention for major out-of-area operations in the post-Cold War era. The ability to "go beyond collective defense and to conduct new security missions" enabled NATO to remain relevant in this new era.⁸⁷ It was believed by both "NATO supporters and NATO critics...that the Alliance would have to go 'out of area' or it would go 'out of business.'"⁸⁸

From August 30 through September 20, 1995, ODF would come to represent the most forceful use of military power to date by NATO. Under the leadership of Admiral Leighton W. Smith, ODF was comprised of 16 nations, totaling over 5,000 personnel. For two-and-a-half weeks, NATO orchestrated "an air campaign designed to coerce Serbia into negotiating an end to the civil war" and lifting the siege of Sarajevo.⁸⁹ Furthermore, in conjunction with the ongoing Operation Deny Flight, NATO employed a total of thirteen TLAMs, causing substantial damage to key Serb infrastructures (communication suites, air

⁸⁷Ryan C. Hendrickson, "Crossing the Rubicon," *NATO Review*, 2005, 2.

⁸⁸*Ibid.*

⁸⁹Mahnken, *Technology*, 182.

defenses, radars, armors, etc.).⁹⁰ Thus, the precision strikes were conducted with a limited number of cruise missiles; they nonetheless played a significant role in bringing a resolution to the situation.

To understand the true significance of ODF, one must look at the decline of the Federal Republic of Yugoslavia during the early 1990s. Understanding this complex history helps in highlighting the critical causes that brought about “the death of Yugoslavia” and NATO’s decision to conduct ODF. Throughout the early 1990s, because of ethnic tensions, economic decline, and false claims and promises made by Slobodan Milosevic, then president of the Federal Republic of Yugoslavia, the successor states of the Socialist Federal Republic of Yugoslavia became engulfed in a civil war and inter-state wars. Furthermore, tensions elevated because of the declarations of independence by Slovenia and Croatia in 1991. By the spring of 1992, six other nations surrounding Bosnia had declared independence. This turmoil contributed to the ongoing violence in Bosnia-Herzegovina. As these newly independent nations sought to acquire more Bosnian territory, this only compounded the ethnic tension that left Yugoslavia in a precarious position throughout the early 1990s. In response to the prolonged fighting that resulted in a heavy loss of life, the United Nations inserted a protection force (UNPROFOR), which implemented a series of unsuccessful cease-fire agreements with Milosevic and his forces. The resolution mandated that UNPROFOR provide security and humanitarian aid for refugees until the end of the Bosnian war. However, UNPROFOR and the cease-fire agreements were not enough to defuse the situation. Serbian forces acting under the orders of Milosevic performed widespread ethnic cleansing throughout Bosnia, “creating horrific scenes of refugees and concentration camps that seemed unthinkable in modern Europe.”⁹¹ Furthermore, by mid-1993, the BSA was attacking designated

⁹⁰Janes, “RGM/UGM-109 Tomahawk.”

⁹¹Department of Defense, “The War in Bosnia, 1992-1995,” Office of the Historian, last accessed February 4, 2014 <https://history.state.gov/milestones/1993-2000/bosnia>.

safe areas. This was a turning point for the UN, as it was now realized that its primary mission (providing security for the citizens of Bosnia) was failing.

The UN decided to authorize the use of airpower. This authorization “established a ‘dual key’ arrangement between the U.N. and NATO in control of tactical air power” in response to the overwhelming attacks by Serbian forces.⁹² Nonetheless, it was stated, “This arrangement proved difficult for Washington, as the U.N. was extremely reluctant to authorize any effective combat action on part of NATO.”⁹³ However, despite this somewhat strained relationship between the UN and NATO, limited air strikes were carried out by the coalition. These air strikes were initially believed to be sufficient to bring Milosevic and his forces to the bargaining table. However, they had the opposite effect. By April of 1995, Milosevic and his forces held over 300 UN peacekeepers as hostages. It was documented that those taken as hostages were subsequently used as human shields, in an attempt to prevent the coalition from continuing its extensive air strikes against the Serbs. Ultimately, the UN stopped conducting air strikes in an attempt to save lives of the hostages. Yet, with the halting of air strikes, Milosevic continued his methodical assault against designated safe areas. By the spring of 1995, these designated areas were once again being shelled, as heavy weapons continued to be moved back inside the mandated exclusion zone. The UN and could do little at this point due to the strict limitations mandated by UNSC Resolutions. As a result, the UN and NATO “agreed on the effective end of the ‘dual key’ policy for controlling air strikes, with authority for strikes delegated to UNPROFOR and NATO commanders in the field. The Alliance further agreed that any future attacks on safe areas would result in a sustained air offensive.”⁹⁴

On August 28, 1995, the BSA shelled a UN-designated safe area. The circumstances surrounding these mortar attacks, and the staggering loss of life they caused, compelled NATO to take action. This was a well-defined trigger for

⁹²Ibid.

⁹³Ibid.

⁹⁴Ibid.

NATO air operations, which had been previously established for the coalition by the ending of Resolution 743. Furthermore, the Sarajevo offensives were “portrayed in color on CNN worldwide,” and the allies held that “the compelling force of world public opinion” required decisive military force by NATO.⁹⁵ On August 30, 1995, NATO began an historic air campaign that eventually brought Milosevic and his forces to the bargaining table. ODF was a distinctive NATO operation, in which airpower became NATO’s instrument of choice. The use of air power had a tremendous psychological, political, and strategic effect upon the outcome of the operation. Precision-guided munitions (including Tomahawks) were used throughout the operation in an effort to ensure maximum efficiency. This afforded NATO forces the opportunity to strive to strike only military targets. Targets such as radio relays, ammunition storage sites, early warning radars, supply depots, and other essential military facilities were destroyed. By mid-September 1995, the combination of various types of NATO aircraft, together with the use of TLAMs, severely degraded Milosevic’s forces. It was estimated that the combination of the Alliance’s aircraft and Tomahawk cruise missiles was responsible for the destruction of a large number of Serbian military targets, and that a high proportion of the munitions used were precision guided. By the end of September 1995, both sides terminated all fighting. The effective use of airpower and precision airstrikes aided in bringing the Bosnia war to an end, and led ultimately to the Dayton Accords.

ODF accomplished two major things. First and foremost, it showed that the NATO allies could act together effectively as a coalition. Additionally, it showed the need for NATO in the post-Cold War era. The decisive use of airpower, including precision airstrikes, played a critical role in support of Allied diplomacy. ODF provided future leaders an in-depth understanding of the use of airpower and its significance for future foreign policy. As noted in Chapter I, airpower served as “a decisive element in bringing a new period of peace to

⁹⁵David L. Dittmer and Stephen P. Dawkins, *Deliberate Force: NATO’s First Extended Air Operation: The View from AFSOUTH* (Alexandria: Center for Naval Analyses, 1998), 2

Bosnia—quickly, cleanly, and at a minimal cost in blood and treasure to the intervening states and, indeed, to the Bosnian Serbs.”⁹⁶ Additionally, the Alliance’s actions in Bosnia illuminated the importance of the political-military environment for future operations. As pointed out previously, despite the sometimes “tenuous” relationship between the UN and NATO, the Bosnia operations “highlighted the ability of separate political and military organizations to work together.”⁹⁷ The successful use of airpower would within a few years again be central to the Alliance’s political-military mission.

B. OPERATION ALLIED FORCE (KOSOVO CAMPAIGN)

In the late 1990s, NATO undertook another significant operation in the Balkans, Operation Allied Force (OAF). On March 24, 1999, after failed attempts to end the violence, repression, and violations of human rights ordered against ethnic Albanians in Kosovo by the elected president of the Federal Republic of Yugoslavia (FRY), Slobodan Milosevic, NATO conducted OAF by relying exclusively on air power. After seventy-eight days of NATO precision strikes upon many high-priority targets in the FRY, Milosevic agreed to pull his forces out of Kosovo and allowed the nearly one million displaced ethnic Albanians to return to their homes. Airpower provided a victory for NATO and demonstrated its ability to bring an adversary to the bargaining table.

Nonetheless, to understand the reasons behind OAF and NATO’s exclusive use of airpower, one must look at the environment dating back to the Bosnian war. In 1992, war erupted in the former Yugoslavia. In an attempt to extend Serbian control, Serbian forces, under the orders of Milosevic, systematically brutalized Muslims and Croats in Bosnia and Croatia. For over three years, fighting in Bosnia and Croatia raged on, leaving hundreds of thousands dead and over a million people displaced. In the case of Bosnia, the United States and its NATO allies held Milosevic responsible for these deaths

⁹⁶Owen, *Deliberate Force: A Case Study in Effective Air Campaigning*, 515.

⁹⁷*Ibid.*, 60.

and displacements, and on August 30, 1995 initiated ODF to bring an end to this war. After concluding OAF, stability in Bosnia grew, whereas, in Kosovo it grew progressively less.

By the fall of 1998, Milosevic returned to his previous policies. He ordered Serbian forces to attack all ethnic Albanian villages in the Serbian province of Kosovo. When diplomatic efforts stalled and the violence in Kosovo intensified, NATO refused to stand idle. The NATO Alliance decided to strike and commenced OAF on March 24, 1999 to prevent a repetition of the Bosnian tragedy. As stated by Benjamin S. Lambeth, OAF came to represent “the first extended use of military force by NATO, as well as the first major combat operation conducted for humanitarian objectives against a state committing atrocities within its own borders.”⁹⁸ Employing only airpower, NATO commenced a multitude of precision strikes against carefully selected targets in the FRY. These precision strikes had three objectives; first, to demonstrate NATO’s opposition to this aggression and its support for peace; second, to deter president Milosevic from continuing his escalated attacks; and lastly, to damage the Serbian capacity to wage war against the ethnic Albanians in Kosovo in the future by seriously diminishing Serbian military capabilities.

NATO member nations were unanimous in their desire to stop Milosevic; however, there were fundamental differences of opinion over exactly how NATO’s military power should be used against him. As noted previously, according to Wesley K. Clark, who served as Supreme Allied Commander Europe as well as the U.S. European Command Commander during Operation Allied Force, “The United States was increasingly committed to the idea of strategic strikes, going after the heart of Milosevic’s power. The Europeans, or at least the French and a few others, were more interested in limiting the strikes to Kosovo, trying to hit the ground forces, and avoiding actions that might

⁹⁸Benjamin S. Lambeth, *NATO’s Air War for Kosovo: A Strategic and Operational Assessment* (Santa Monica: RAND Corporation, 2001), 219.

antagonize or damage Serbia further.”⁹⁹ These fundamental differences stemmed in part from a “dichotomy between political aims and military means.”¹⁰⁰ Furthermore, this discord among the Alliance’s leaders led to its failure to capitalize on NATO’s air power.¹⁰¹

Accordingly, NATO decided to fight a limited war. The allies attacked only carefully selected targets in Serbia and Kosovo, employing the most accurate weapons (bombs and missiles) in their military arsenal. As stated by Anthony Cordesman, “the majority of direct attack weapons employed during Operation Allied Force were laser-guided bombs. In addition, long-range, stand-off munitions such as the Tomahawk Land Attack Missile (TLAM) and the Conventional Air Launched Cruise Missile (CALCM) were employed extensively, especially during the initial stages of the operation and in periods of adverse weather.”¹⁰² These weapons were launched from a variety of platforms by the United States and the United Kingdom: surface, subsurface, and air platforms for the United States and only subsurface platforms for the United Kingdom.¹⁰³

Partly because NATO had ruled out the use of ground forces in Kosovo, and chose to rely heavily on the use of airpower, the initial phases of OAF got off to a rocky start. NATO’s efforts to establish air superiority over Kosovo and suppress air-defense systems and communications capabilities throughout the Federal Republic of Yugoslavia were hampered by the elements. Over half of NATO’s combat missions were canceled due to bad weather. This resulted in the employment of cruise missiles during the initial days of the campaign and during periods of adverse weather. During OAF, two NATO allies, the United States and

⁹⁹Wesley K. Clark, *Waging Modern War: Bosnia, Kosovo, and the Future of Combat* (New York: Public Affairs, 2001), 237.

¹⁰⁰*Ibid.*, 244.

¹⁰¹*Ibid.*, 185.

¹⁰²Anthony H. Cordesman, *The Lessons and Non-Lessons of the Air and Missile Campaign in Kosovo* (Westport: Praeger, 2001), 46.

¹⁰³*Kosovo/Operation Allied Force After-Action Report to Congress* (Washington, DC: U.S. Department of Defense, 31 January 2000), 92.

the United Kingdom, launched exactly 238 cruise missiles combined, including both TLAMs and CALCMs. However, the United States shouldered the responsibility for a significant number of the cruise missiles launched, due to its unique capabilities in all-weather precision strikes. It was estimated that the United States launched over ninety percent of the Tomahawks, hitting over eighty percent of their targets (181 of 218). Although the United Kingdom forces were limited in their participation, they were able to launch a total of twenty Tomahawks, likewise hitting over eighty percent of their targets (17 of 20).¹⁰⁴

However, although these cruise missile strikes were undertaken in conjunction with manned aircraft operations, airpower did little to deter Milosevic from his series of brutal offensives. Meanwhile, aggression against ethnic Albanians continued to accelerate. Without troops on the ground, NATO could not establish safe havens for the citizens of Kosovo. Many became vulnerable to both atrocities at the hands of Serbian forces and accidental collateral damage from the NATO air strikes. The refugees who had safely escaped entered neighboring countries that were ill prepared to receive them. NATO's exclusive reliance on airpower failed to stop the forced exodus of ethnic Albanians.

Not until the last month of the operation did NATO finally see progress. During this time, NATO intensified its strikes against a new list of targets in Kosovo and Serbia, including such targets as water and power plants. This created a political climate conducive to major concessions. It caused worry in the regime over damage to "dual-use" infrastructures, and deepened fear of unconstrained bombing on Serbia if NATO's terms were rejected. In Stephen T. Hosmer's view, these factors "appear to have shaped Milosevic's decisionmaking" in conceding in early June of 1999.¹⁰⁵ At the same time, Russia was beginning to press Milosevic into conceding to NATO's demands. On June

¹⁰⁴Ibid., 22; Janes, "RGM/UGM-109 Tomahawk."

¹⁰⁵Stephen T. Hosmer, "The Conflict Over Kosovo: Why Milosevic Decided to Settle When He Did" (Santa Monica, CA: RAND Corporation, 2001), 1, 65.

10, 1999, Milosevic agreed to NATO's demands, and pulled his forces out of Kosovo, allowing all ethnic Albanians to return to their homes.

NATO leaders credited their exclusive reliance on airpower as the source of victory in OAF. The strategic portion of the seventy-eight day air campaign, which ended on June 9, 1999, played a crucial role in convincing Milosevic to "halt and reverse the human rights abuses that were being committed by armed Serbs against the ethnic Albanian majority living in Yugoslavia's Serbian province of Kosovo."¹⁰⁶ Though every objective set out by NATO was achieved, other contributing factors should be taken into account in analyzing the reasons for NATO's success in OAF, such as Russia's contribution in bringing this conflict to an end and NATO's threat of an invasion by ground troops.¹⁰⁷

OAF highlighted the major problems in relying exclusively on air power. As seen in OAF, air power alone was not enough to stop brutal attacks on the ground. NATO's ruling out the use of ground forces in Kosovo at the outset was a grave tactical error. In the absence of NATO ground forces, Milosevic was able to use a variety of techniques to divert and deceive NATO war planners. This presented Milosevic's forces ample opportunities to continue "ethnic cleansing" throughout Kosovo. In some ways, Milosevic was successful during the course of the war. He held the world's strongest military Alliance (NATO) at bay, while his forces swept through Kosovo brutalizing ethnic Albanians. Unlike ODF, OAF showed that an exclusive reliance on airpower will not necessarily bring about a quick and decisive victory. Coming to grips with the limits of air power is vital to both political and military planners in future military operations. Nevertheless, "NATO demonstrated both the unwavering political cohesion and unmatched

¹⁰⁶Benjamin S. Lambeth, *NATO's Air War for Kosovo: A Strategic and Operational Assessment* (Arlington: Rand Publishing, 2001), v.

¹⁰⁷Daniel L. Byman and Matthew C. Waxman, "Kosovo and the Great Air Power Debate," *International Security* 24, no. 4 (Spring 2000); Anthony H. Cordesman, *The Lessons and Non-Lessons of the Air and Missile Campaign in Kosovo* (Westport: Praeger, 2001); Ivo H. Daalder and Michael E. O'Hanlon, *Winning Ugly: NATO's War to Save Kosovo* (Washington, DC: The Brookings Institution, 2000); Benjamin S. Lambeth, *NATO's Air War for Kosovo* (Santa Monica: RAND Corporation, 2001); and Wesley K. Clark, *Waging Modern War: Bosnia, Kosovo, and the Future of Combat* (New York: Public Affairs, 2001).

military capability that will be required to overcome the complex and unpredictable security challenges of the 21st century.”¹⁰⁸ Despite the many divisive pressures faced by the NATO allies, their determination and ability ultimately afforded a clear victory for OAF.

C. OPERATION UNIFIED PROTECTOR (LIBYA CAMPAIGN)

Some observers hold that Operation Unified Protector (OUP) has left the NATO Alliance with a stylized template for future operations. As stated by Daalder and Stavridis in “NATO’s Victory in Libya: The Right Way to Run an Intervention,” OUP has “rightly been hailed as a model intervention.”¹⁰⁹ OUP is in a class of its own. In the words of Douglas C. Lovelace, Jr., NATO “military action in Libya was a first in many ways—the Alliance’s first combat operation against an Arab country; the first time the United States ‘led from behind;’ and the first time the concept of Responsibility to Protect was applied to support Libya’s civilian population against a murderous regime.”¹¹⁰

In early 2011, trouble was brewing in Libya, and again the United States and the NATO Alliance were compelled to take action. This time it was to impede and stop the terrorism being carried out by Colonel Muammar Gaddafi and his military forces. The immediate roots of Libya’s crisis lie in the political upheavals associated with the Arab Spring, in which revolutionary waves of demonstrations and protests swept throughout the Arab world in the early months of 2011.¹¹¹ But, to understand the reasons behind the Arab Spring, one must look back to December 2010, when one man changed the Arab world.

¹⁰⁸Kosovo/Operation Allied Force After-Action, xviii.

¹⁰⁹Daalder and Stavridis, “NATO’s Victory in Libya,” 2.

¹¹⁰Florence Gaub, “The North Atlantic Treaty Organization and Libya: Reviewing Operation Unified Protector,” *The Letort Papers* (Carlisle: Strategic Studies Institute U.S. Army War College, 2013), iii.

¹¹¹Alex J. Bellamy and Paul D. Williams, “The New Politics of Protection? Cote d’Ivoire, Libya and the Responsibility to Protect,” 838.

On December 17, 2010, Mohamed Al Bouazizi, a Tunisian street vendor, was selling fruit and vegetables from a cart as he did daily to provide for his family. Bouazizi, who was identified as operating an illegal business, had his means of livelihood (his cart) confiscated by a government official. The alleged reason behind the confiscation of his cart was that Bouazizi did not have a proper permit to sell. The circumstances surrounding this event are not entirely clear, but subsequently Bouazizi became outraged. A CNN report suggested that Bouazizi became outraged because a “police officer slapped him across his face” after the confiscation. Other reports hold that “Al Bouazizi tried to complain at a center for unemployed graduates—but that no one listened to him and he heard only laughter and insults.”¹¹² Whatever the reasons might be, the following events sparked a worldwide revolution, a domino effect that swept through a host of other North African and Middle Eastern countries (e.g., Egypt, Djibouti, Ivory Coast, Libya, Mali). Bouazizi decided that he was not going to stand for this anymore, and immolated himself as a protest against the corrupt and oppressive government of Tunisia. His immolation incited a popular uprising, which became known as the Arab Spring. Enraged by this event, the citizens of Tunisia rose up against their oppressive government, staging waves of demonstrations and protests lasting for weeks and weeks. This revolution was so powerful that the Tunisian President, Ben Ali, decided to step down, ultimately ending his twenty-three year reign. Though Bouazizi did not see this historic outcome, the revolution in Tunisia was successful. It provided the example that citizens of other oppressed countries followed.

In February 2011, the election in Libya became volatile. As with every other country that participated in the Arab Spring, in Libya demonstrations and protests started spontaneously. Mohammed Ali Abdullah, a Libyan opposition figure, stated:

¹¹²CNN World, “How a Fruit Seller Caused Revolution in Tunisia,” January 16, 2011, last accessed February 3, 2014, <http://www.cnn.com/2011/WORLD/africa/01/16/tunisia.fruit.seller.bouazizi/>.

People have now been empowered to make a statement. Enough. Forty-two years of oppression. Forty-two years of a dictatorial totalitarian rule is enough. The source of the problem is the same person and it starts with getting rid of him, and that's the common denominator that gets all the people to come out for these demonstrations.¹¹³

However, these initial demonstrations and protests quickly became violent, as Gaddafi's forces intensified their crackdown against the demonstrators. Gaddafi, determined to remain in power, was prepared to kill thousands of people, if necessary. According to Alex J. Bellamy and Paul D. Williams, Gaddafi warned the "world that 'officers have been deployed in all tribes and regions so that they can purify all decisions from these cockroaches' and 'any Libyan who takes arms against Libya will be executed.'"¹¹⁴ Furthermore, Gaddafi "vowed to fight to the death rather than leave Libya."¹¹⁵ During the initial days of protest, it was estimated that Gaddafi's forces killed 230 demonstrators.¹¹⁶

Throughout the next couple of months, violence would only intensify in Libya, causing grave concern for the United Nations. To aid the citizens of Libya, the United Nations Security Council (UNSC) decided to approve two significant UNSC Resolutions: UNSCR 1970 and UNSCR 1973.

UNSCR 1970 (February 26, 2011) referred the situation in Libya since February 15, 2011 to the Prosecutor of the International Criminal Court (ICC), imposed an arms embargo on Libya, and established travel bans and asset freezes on key figures in the Qadhafi regime. UNSCR 1973 (March 17, 2011) authorized:

¹¹³"Live: Mid-East protests", BBC News Online, 16 February 2011

¹¹⁴Bellamy and Williams, "The New Politics of Protection," 838.

¹¹⁵Ben Smith, "Turmoil in the Middle East," House of Commons Library, International Affairs and Defence Section, March 28, 2011, 15.

¹¹⁶Human Rights Watch, "Libya: Governments Should Demand End to Unlawful Killings," February 20, 2011, last accessed January 27, 2014, <http://www.hrw.org/news/2011/02/20/libya-governments-should-demand-end-unlawful-killings>.

Member States that have notified the Secretary-General, acting nationally or through regional organizations or arrangements, and acting in cooperation with the Secretary-General, to take all necessary measures . . . to protect civilians and civilian populated areas under threat of attack in the Libyan Arab Jamahiriya, including Benghazi, while excluding a foreign occupation force of any form on any part of Libyan territory.¹¹⁷

UNSCR 1973 also called for a no-fly-zone, redefined the terms of the arms embargo, and extended the scope of the asset freeze.¹¹⁸

For the first time in the UNSC's history, the use of force for civilian protection "against the wishes of a functioning state" was authorized.¹¹⁹ As stated by Daniel F. Baltrusaitis and Mark E. Duckenfield, "The commitment of NATO to quell civil unrest in Libya in February 2011, and protect the civilian population from the regime of Colonel Muammar Gaddafi, ushered in a new era of NATO cooperation."¹²⁰ These actions were significant, because NATO was taking "all [the] necessary measures...to protect civilians and civilian populated areas under threat of attacks in the Libyan Arab Jamahiriya, including Benghazi."¹²¹

In support of UNSC Resolutions 1970 and 1973, on March 19, 2011, three key states in "the coalition of the willing," France, the United Kingdom, and the United States took action, termed as Operation Odyssey Dawn (OOD).¹²² From March 19 to March 31, these three NATO members employed precision strikes in

¹¹⁷United Nations, "Security Council Approves 'No-fly Zone' Over Libya, Authorizing 'All Necessary Measures' to Protect Civilians," Security Council SC/10200, last accessed February 13, 2014, <https://www.un.org/News/Press/docs/2011/sc10200.doc.htm>.

¹¹⁸UNSCRs 1970 and 1973.

¹¹⁹Bellamy and Williams, "The New Politics of Protection," 825.

¹²⁰Daniel F. Baltrusaitis and Mark E. Duckenfield, "Operation Unified Protector: Triumph or Warning Sign," *Baltic Security and Defence Review* 14, Issue 2, (2012), 21.

¹²¹Jermiah Gertler, "Operation Odyssey Dawn (Libya): Background and Issues for Congress," Congressional Research Service, (2011), 2.

¹²²Chris Pocock, "NATO's Role in Gaddafi's Downfall: Operation Unified Protector." AINonline, November 13, 2011, last accessed February 17, 2014, <http://www.ainonline.com/aviation-news/dubai-air-show/2011-11-10/natos-role-ghaddafis-downfall-operation-unified-protector>.

an effort to prevent a “humanitarian catastrophe and address the threat posed to international peace and security by the crisis in Libya and for the purposes of preparing a no-fly zone.”¹²³ Though it was declared a limited operation, U.S. military forces and capabilities were of paramount importance. As stated by Chris Pocock:

It seems only the U.S. had the firepower to ensure that the essential first objective of suppressing Libyan air defenses was achieved. By the eighth day of the campaign, the U.S. had fired 184 BGM-109s Tomahawk cruise missiles from ships and submarines against radars, surface-to-air missile sites and communications nodes. As for Libyan air bases, there was one attack by three American Northrop B-2s, flying a 24-hour round-robin mission from their home base in Missouri.¹²⁴

Though the initial strikes were mostly executed by the United States, OOD was able to quickly establish air superiority over Libya’s major cities. As stated by the President of the United States, Barack Obama:

We’re succeeding in our mission. We’ve taken out Libya’s air defenses. Qaddafi’s forces are no longer advancing across Libya... So make no mistake, because we acted quickly, a humanitarian catastrophe has been avoided and the lives of countless civilians—innocent men, women and children—have been saved... Our allies and partners are enforcing the no fly zone over Libya and the arms embargo at sea. Key Arab partners like Qatar and the United Arab Emirates have committed aircraft. And as agreed this week, responsibility for this operation is being transferred from the United States to our NATO allies and partners.¹²⁵

In conjunction with the efforts of local rebels, OOD was seen by NATO commanders as an effective means to prevent acts of terror by Gaddafi and his forces. As the “coalition of the willing” conducted the first phases of the Libya

¹²³Jermiah Gertler, “Operation Odyssey Dawn (Libya): Background and Issues for Congress,” march 30, 2011, last accessed February 3, 2014, http://assets.opencrs.com/rpts/R41725_20110330.pdf.

¹²⁴Pocock, “NATO’s Role in Ghaddafi’s Downfall.”

¹²⁵Weekly Address, The White House, Office of the Press Secretary, March 26, 2011, last accessed February 20, 2014, <http://www.whitehouse.gov/the-press-office/2011/03/26/weekly-address-president-obama-says-mission-libya-succeeding>.

campaign, Gaddafi and his forces seemed headed for a quick defeat. However, this assumption turned out to be mistaken, as Gaddafi and his forces refused to accept NATO demands. These circumstances required NATO to expand the scope of its mission in Libya.

On March 30, 2011, after two weeks of air operations under U.S. command, NATO took command and control over all military operations in Libya. For the first time in NATO operations the United States was now playing a supporting role, in which capabilities such as intelligence and logistical support were being provided. This new phase became known as Operation Unified Protector (OUP). Following OOD, OUP continued to operate at a high tempo, continuing to enforce the arms embargo and the no-fly zone, and to employ precision strikes against key targets. NATO and Gaddafi forces were locked in a battle until the death of Gaddafi on October 20, 2011. As proclaimed by the Obama administration, his death “marked ‘the start of a new era’ for the people of Libya.”¹²⁶ Military actions by NATO ended in October 2011.

However, the rapid escalation of the Libya campaign revealed divisions among NATO members. According to Baltrusaitis and Duckenfield, “the Libya operation spawned the most controversial diplomatic rift in the Alliance since the U.S. invasion of Iraq, with the resistance of Germany and Turkey continuing to illustrate fundamental differences about NATO’s use of force.”¹²⁷ Yet, despite these circumstances, OOD and OUP were successful due to the impact of NATO actions. The capability of airpower aided NATO in ensuring the achievement of the UNSC mandate, by preventing a humanitarian catastrophe, and thus protecting the citizens of Libya. Without airpower, the Alliance undertakings in Libya might have failed. The prompt actions taken by NATO saved the citizens of Libya from Gaddafi and his forces. The NATO allies and Partners achieved these objectives with minimal damage to their forces.

¹²⁶Kjell Engelbrekt, Marucs Mohlin, and Charlotte Wagnsson, *The NATO Intervention in Libya: Lessons Learned From the Campaign* (New York: Routledge Publisher, 2014), xvi.

¹²⁷Baltrusaitis and Duckenfield, “Operation Unified Protector,” 30.

Yet, OOD and OUP exposed additional deep-rooted challenges (including excessive reliance on the United States and capability gaps within the Alliance) that have affected NATO since its inception. As pointed out by the NATO Secretary General, Anders Fogh Rasmussen, “The operation has made visible that the Europeans lack a number of essential military capabilities.”¹²⁸ During both operations, Operation Odyssey Dawn and Operation Unified Protector, it was estimated that the United States launched over ninety percent of the Tomahawk cruise missiles, and provided over eighty percent of all air-refueling and reconnaissance flights. The majority of the remaining support came primarily from France and the United Kingdom.

Without the assistance of the United States, clearly, Operation Unified Protector would not have been as successful as it was.

¹²⁸Eric Westervelt, “NATO’s Intervention in Libya: A New Model?” September 12, 2011, last accessed February 3, 2014, <http://www.npr.org/2011/09/12/140292920/natos-intervention-in-libya-a-new-model>.

IV. THE CAPABILITIES GAP OF THE ALLIANCE

In 1949, NATO was established as an “alliance organized to defend its members from external coercion or aggression and, on that basis, to conduct diplomacy with its adversaries to the East and seek a peaceful resolution to East-West differences.”¹²⁹ However, after the collapse of the Soviet Union, the geostrategic context for NATO transformed significantly, thus creating a new set of security threats (increases in ethnic conflicts, terrorist threats, nuclear proliferation, organized crime, etc.) and “concerns that diminished the immediacy of NATO’s two key functions as an alliance: the Article 5 collective defense obligation and the credibility of the American nuclear guarantee underwriting it.”¹³⁰ For NATO to remain relevant, its members had to focus on its overall purpose of collective defense and contribute to collective security in the post-Cold War world, in which several internal and external factors have transformed. While the Alliance remains a collective defense organization, today, allies have nonetheless assumed additional roles in cooperative security, conflict prevention, and crisis management.

In all of the aforementioned operations, one thing has remained the same; the United States has played the dominant role. Excluding OUP, in which the United States was seen as “leading from behind,” all of the operations have depended on U.S. leadership. It can be said that, even within OUP, the United States did the majority of the “heavy lifting”: logistically, with aircraft fuelers; technologically, with precision-guided munitions and intelligence; and operationally, with combat power considering the proportion of U.S. sorties during the operation, especially in the initial phase. The conflicts in the Balkans

¹²⁹David S. Yost, *NATO Transformed: The Alliance’s New Roles in International Security*, (DC: Unites States Institute of Peace Press, 1998), 1.

¹³⁰Mark Webber, James Sperling, and Martin A. Smith, *NATO’s Post-Cold War Trajectory: Decline and Regeneration*, (Palgrave MacMillian, 2012), 155.

and Libya have revealed a major concern for the NATO Alliance, the operational capabilities gap between the United States and its NATO allies. As observed by the then NATO Secretary General, Lord Robertson:

The Kosovo air campaign demonstrated just how dependent the European Allies had become on U.S. military capabilities. From precision-guided weapons and all-weather aircraft to ground troops that can get to the crisis quickly and then stay there with adequate logistical support, the European Allies did not have enough of the right stuff.... Something is wrong and Europe knows it.¹³¹

In this thesis, the operational capabilities gap is defined as a collection of many gaps, including timely availability, validated intelligence, deployability and mobility, effective engagement, command and control, logistic support, and survivability and force protection.

- Timely availability includes high readiness, highly mobile and lethal forces, equipped and trained for covert and overt missions in complex terrain, such as special operations forces and mountain forces.
- Validated intelligence includes strategic reconnaissance (satellites); signals intelligence; early warning and distant detection; target acquisition; battlefield intelligence and strategic reconnaissance; and Human Intelligence.
- Deployability and mobility include air and sea lift capabilities; with an emphasis on wide body aircraft and Roll on/Roll off ships; and air-to-air refueling.
- Effective engagement includes the following shortfalls: precision guided munitions; stand-off weaponry, including cruise missiles; and attack helicopters
- Command and control involve the following deficiencies: secure and deployable C4 (Command, Control, Communications, Computers).
- Logistic support involves tactical lift, notably transport helicopters; and tracking and tracing systems

¹³¹Lord George Robertson, "Rebalancing NATO for a Strong Future," Remarks at the Defence Week Conference, Brussels, Belgium, 31 January 2000, last accessed February 2, 2014, <http://www.nato.int/docu/speech/2000/s000131a.htm>.

- Survivability and force protection involves Suppression of Enemy Air Defenses; NBC protection and detection, and Combat Search and Rescue.¹³²

These essential operational capabilities provide the United States with a significant advantage, and the capability of projecting power “in the form of large-scale long-range non-nuclear air and missile strikes at great distances from its homeland.”¹³³ Additionally, of all the NATO allies, “only the United States can deploy hundreds of military aircraft far beyond its homeland and even transport the logistics to upgrade airfields with limited facilities.”¹³⁴ The ability to forward deploy forces in a given proximity of a conflict or potential conflict has enabled the United States to play a dominant role in setting the agenda in NATO. However, at the same time, this “new dynamic in the transatlantic security relationship . . . makes the current imbalance between the U.S. and its allies unsustainable over the long run. Changing U.S. strategic interests, finite resources and a generational change are all making Washington’s political elite ever more skeptical about the value of the alliance.”¹³⁵

Some observers have argued that since the inception of NATO this capability gap has been a major concern for the alliance and that it has increased significantly between the United States and its NATO allies. In the words of Daniel S. Hamilton, “The U.S. and its allies have struggled for half a century with gaps in capabilities, questions of interoperability, and debates about burden-sharing.”¹³⁶ However, it seems that since the conclusion of OUP, there has been considerable discussion generated about the capabilities gap between the United States and its allies. Today, one must highlight a major weakness of the alliance, that is, the weakness of the alliance without United States military capabilities.

¹³²Daniel S. Hamilton, ed. *Transatlantic Transformations: Equipping NATO for the 21st Century* (Washington, DC: Center for Transatlantic Relations, 2004), 128-129.

¹³³David S. Yost, “The NATO Capabilities Gap and the European Union,” 98-99.

¹³⁴*Ibid.*, 99.

¹³⁵Ellen Hallams and Benjamin Schreer “Towards a ‘post-American alliance?: NATO burden-sharing after Libya,” *International Affairs*, 2012, 314.

¹³⁶Hamilton, *Transatlantic Transformations*, 6.

One must discuss the potential inadequacy of the Alliance to deal with future conflicts, small or big, without United States assistance. As stated by Robert Gates, then the U.S. Secretary of Defense, “NATO had finally become a two-tiered alliance divided between those few allies capable of engaging in high intensity combat missions and the overwhelming [of] members that can only contribute extensively to soft power non-combat oriented missions.”¹³⁷ Likewise, according to David S. Yost, “the defence-capabilities gap that divides the United States from its European allies is real, and it matters.”¹³⁸ Now it is time to confront this issue head on, using the most recent major operation as an example.

For the first time in NATO’s history, the United States took on a supporting role during OUP, commonly referred to as the United States’ “leading from behind.” Initially, for the first couple of weeks, OUP was under the command of the United States, until the handing off of responsibility to two leading NATO European powers, France and the United Kingdom. Though the U.S. role was limited in OUP, the United States nonetheless provided an array of capabilities for its NATO allies, such as effective engagement (i.e., precision strikes), command and control, deployability and mobility (i.e., air-to-air refueling), and intelligence. Without the assistance of the United States, Operation Unified Protector would not have been as successful as it was. As Kori Schake has observed, “The [Libya] conflict would have taken longer, inflicted more civilian casualties and damage, taken more allied casualties, and been (as the British say) a much closer run thing.”¹³⁹ From the beginning of the operation, to its eventual conclusion, these essential operational capabilities were instrumental for the NATO Alliance and provided a significant advantage during OUP.

¹³⁷Gates paraphrased in Baltrusaitis and Duckenfield, “Operation Unified Protector,” 21.

¹³⁸Yost, “The NATO Capabilities Gap,” 97.

¹³⁹Kori Schake in Francois Heisbourg et al., *All Alone? What US Retrenchment Means for Europe and NATO*, Centre for European Reform, 9.

However, the Libya campaign highlighted a number of disparities between the U.S. capabilities and those of its allies. As stated by Robert Gates, the then Secretary of Defense,

...while every alliance member voted for the Libya mission, less than half have participated at all, and fewer than a third have been willing to participate in the strike mission. Frankly, many of those allies sitting on the sidelines do so not because they do not want to participate, but simply because they can't. The military capabilities simply aren't there.¹⁴⁰

Furthermore, OUP revealed the necessity of U.S. military capabilities within the alliance. This significant inadequacy of NATO capabilities raises several concerns for the alliance in the twentieth-first century. What if the United States chose not to participate in future NATO operations, as several other allies did in the Libya case? Is this a blueprint for the future? As the United States shifts its focus to the Asia-Pacific region, the capabilities requirement for its European allies will be significant. The NATO allies will eventually become responsible for protecting themselves and their own backyard. It is becoming paramount for the NATO alliance to decrease this military capability gap. If not, NATO will continue to be a two-tier alliance with nations having varying objectives, capabilities, and commitments. As stated by George Robertson, "it will be vital to avoid a two-tier Alliance, whereby, as a French observer once put it, the U.S. does the fighting and the Europeans do the dishes."¹⁴¹

Given that a limited number of NATO members have ownership of key capabilities, such as cruise missiles, early warning systems, etc., one must question the ability of the alliance and highlight the deep concerns in the event of the United States removing its security umbrella. As NATO continues to operate in its crisis management role, the capabilities gap within the alliance will have a serious effect upon its military efficiency and functionality. Moreover, it has been

¹⁴⁰U.S. Department of Defense, "The Security and Defense Agenda (Future of NATO), Speech delivered by Secretary of Defense Robert M. Gates on June 10, 2011, accessed from <http://www.defense.gov/speeches/speech.aspx?speechid=1581>.

¹⁴¹Hamilton, *Transatlantic Transformations*, 32.

argued, this gap will create a political division within the alliance, which has the potential to result in “distinctive U.S. and European views of foreign policy based upon their relative strengths and weakness” to deal with twenty-first century threats.¹⁴² NATO must transform its capabilities to be relevant for the challenges and potential threats of the twenty-first century. By analyzing the disparities seen from not only OUP, but also ODF and OAF, future leaders can plan accordingly to address the challenges of the twenty-first century. Additionally, by addressing this major weakness, NATO will be able to maintain its operational ability and remain effective in its additional roles of conflict prevention and crisis management.

The chances of matching the United States in capability production and quality are slim to none, as the remaining members of the Alliance are ill equipped to take on this task. The United States is a major power with “the luxury of acting with the independence of a single country where a strong consensus exists on behalf of an assertive national security policy and a well-prepared military posture. By contrast, Europe is composed of many medium and small powers that must reach a widespread consensus in order to act collectively.”¹⁴³ Moreover, as operations become more robust, complex, and difficult, operations like OUP have demonstrated that the United States and its allies will continue to work together for the greater good.

In this continuously changing world, the United States faces many threats and challenges. In saying that, one of the biggest threats is the emergence of the Asia-Pacific region, in which countries are now becoming more confident, better armed, and more determined to “play a greater role in controlling its future.”¹⁴⁴ Additionally, the Asia-Pacific region is growing rapidly in its military capabilities, nuclear developments, unresolved territorial and resource disputes, violent

¹⁴²C. Richard Nelson and Jason S. Purcell, ed., “Transforming NATO Forces: European Perspectives,” The Atlantic Council of the United States, (2002), 2.

¹⁴³Ibid., 8.

¹⁴⁴A Changing Paradigm of U.S.-East Asian Relations: Strategic and Economic Perspectives Terence Roehrig Professor, Naval War College National Security Affairs Department April 2011

extremism, natural disasters, proliferation, illicit trafficking and more.¹⁴⁵ What does this mean for the United States? The new prominence of the Asia-Pacific has required the United States to reevaluate its policies and to develop new strategies to serve its interests and those of its allies. As the United States continues its pivot to the Asia-Pacific region, there stands a chance of increased tension within the Alliance and a risk of NATO operations being less effective in the future. Additionally, future NATO operations may require the Europeans to become the primary actor, whereas the United States may play a secondary role, as in OUP.

¹⁴⁵House Armed Services Committee, "Statement of Admiral Samuel J. Locklear, U.S. Navy, Commander, U.S. Pacific Command Before the House Armed Services Committee on U.S. Pacific Command Posture, March 5, 2013, 4.

THIS PAGE INTENTIONALLY LEFT BLANK

V. CRUISE MISSILE TRENDS

The recent success of cruise missiles has caught the eye of the world, and as a result will present a challenge for NATO in the coming years. In the words of Sitakanta Mishra, “By all reckoning, the cruise missile has arrived on the world stage...Many nations have already mastered it and many more are striving for it.”¹⁴⁶ What makes cruise missiles so appealing to governments around the world resides in two essential reasons: “their flexibility, which makes them useful for many purposes, and their comparatively low cost, which makes it possible to deploy them in great quantity.”¹⁴⁷

Today, cruise missiles are increasingly becoming a part of military arsenals worldwide. Once in the hands of a few selected countries (above all, the United States, the United Kingdom, and Russia), the success of cruise missiles is encouraging “a host of nations around the globe—including France, the United Arab Emirates, Germany, Sweden, Spain, India, Pakistan, South Africa, Taiwan, and Iran,” to develop their own generation of these weapons.¹⁴⁸ Does this warrant trouble for the Alliance, when its potential adversaries are exploiting new technology as well? According to David Shukman,

Technologies of a bewildering variety—from nuclear energy to miniature computers to robotics to biological engineering to space-flight—are suddenly on the loose and the completion to find new ways of putting them to military use is no longer the preserve of the most advanced industrial nations. There is now a free-for-all to acquire weapons which may allow even relatively weak countries the chance to leap-frog their way to battlefield superiority.¹⁴⁹

¹⁴⁶Sitakanta Mishra, “Evolution of the Cruise Missile Discourse: A Conceptual Construct,” *Airpower Journal* 4, no. 1, Spring 2009, 113.

¹⁴⁷Betts, *Cruise Missiles and U.S. Policy*, 9.

¹⁴⁸*Ibid.*

¹⁴⁹David Shukman, *Tomorrow's War: The Threat of High-Technology Weapons* (Orlando: Harcourt Brace & Company, 1996), xiii.

Andrew Feickert estimates that there are as many as 130 types of cruise missiles, with over 70 countries possessing them.¹⁵⁰ Christopher Bolkcom and Sharon Squassoni estimate over 80 countries possess them.¹⁵¹ As many as 70,000 cruise missiles are estimated to be operational. Below is a list of some of the NATO and non-NATO countries which are developing or have developed new generation land attack cruise missiles.

A. RUSSIA

Since 2007, Russia has been developing a new generation of hypersonic cruise missiles (3M51 Alfa, 3M-14AE, and Kh-101/102), with the capability of traveling long distances and striking either land or sea targets. It is estimated that these cruise missiles will be in service by 2020.¹⁵²

B. INDIA

Over the last decade, India has been pursuing of its own land attack cruise missile. Similar to the U.S. Tomahawk Land Attack Missile, India's Nirbhay cruise missile is targeted to be ready for service by the end of 2014. As recently as March 2013, India was on track to meet its 2014 target date, but it was set back by an unsuccessful test launch.¹⁵³

C. IRAN

Since 2012, Iran has been developing its own long-range cruise missile program. However, the status of this program remains unknown. According to the

¹⁵⁰Andrew Feickert, "Cruise Missile Proliferation" Washington DC: Congressional Research Service, 2005, 1.

¹⁵¹Christopher Bolkcom and Sharon Squassoni, "Cruise Missile Proliferation" (Washington DC: Congressional Research Service, 2002), 1.

¹⁵²Janes, "Russia Developing Hypersonic Naval Cruise Missiles."

¹⁵³Missile Threat, "India," last accessed September 10, 2013, <http://missilethreat.com/missiles/nirbhay/?country=india#india>.

Iranian Deputy Defense Minister and Head of Iran's Aerospace Organization, General Mehdi Farahi, Iran's cruise missile will have the ability to launch from sea, air, and land platforms.¹⁵⁴

D. TAIWAN

According to Janes, Taiwan's manufacture of a long-range, high-altitude, hypersonic cruise missile will commence soon. Little is known about this endeavor, but it is expected to be ready for introduction by 2015.¹⁵⁵

E. PAKISTAN

As of 2013, Pakistan has two cruise missiles in service. First, Hatf 7 (Babur) is similar to the Tomahawk; it is a ground-launched cruise missile designed to carry either nuclear or conventional payloads. It uses the same guidance applications (TERCOM and DSMAC) as the United States Tomahawk. Second, Hatf 8 (Ra'ad) is an air-launched cruise missile capable of carrying a variety of different warheads.¹⁵⁶

F. GERMANY

As noted previously, Germany pioneered the development of cruise missiles in World War II. However, since 2006, Germany and Sweden have collaborated in developing the Taurus KEPD 350, which features a two-stage warhead system designed to strike a variety of targets, including hard and deeply buried targets. In 2010, the production of this strategic weapon was terminated, as Germany seeks to develop a newer generation missile to keep up with the ever-changing technology and security environment.¹⁵⁷ Capable of delivery from

¹⁵⁴Missile Threat, "Iran," last accessed September 10, 2013, <http://missilethreat.com/missiles/meshkat/?country=iran>.

¹⁵⁵Janes, "Report Reveals Details of Taiwan's Mach 3 Cruise Missile."

¹⁵⁶Missile Threat, "Pakistan," last accessed September 10, 2013, <http://missilethreat.com/missiles-of-the-world/?cruise>

¹⁵⁷Janes, "Germany Takes Delivery of 600th Taurus KEPD 350 Missile."

a vertical launch system, this new generation missile will feature updated infrared-based target recognition and terminal navigation.¹⁵⁸

G. FRANCE

On July 29, 2013, France successfully “carried out the first qualification firing of the MBDA Missile de Croisière Naval (MdCN) cruise missile.”¹⁵⁹ In addition, it has been reported that France and the United Kingdom are working together to develop the “next-generation naval and land attack missile system,” which is estimated to be in service by 2025.¹⁶⁰

Over the past several decades, cruise missiles have improved quite rapidly. The cruise missiles of today are far more sophisticated than those in the past. These improvements have highlighted the potential trajectories for these strategic weapons for not only NATO, but also for many NATO adversaries. It is an open debate whether or not cruise missiles will in the future provide NATO a significant advantage over its adversaries, which leads us to question the end of warfare. Was Leonardo da Vinci correct in his belief that an “invention of some ultimate weapon would not only win battles but also might actually bring an end to warfare itself?”¹⁶¹

Is NATO adequately prepared to defend against this threat? For nearly two decades, the NATO Alliance has for the most part enjoyed the exclusive use of cruise missiles. Nevertheless, the extent of this freedom is under serious challenge. This relatively cheap weapon that possesses the ability of displaying low radar and infrared signatures, coupled with its ability to travel with low-altitude flight profiles, is difficult to detect and defeat.¹⁶² These fundamental

¹⁵⁸Ibid.

¹⁵⁹Janes, “MdCN Cruise Missile Begins Qualification Trials.”

¹⁶⁰Janes, “UK, France Kick Off Joint Studies for Next-Generation Anti-Ship/Cruise Weapon.”

¹⁶¹Paul G. Gillespie, *Weapons of Choice: The Development of Precision Guided Munitions*, (Tuscaloosa: The University of Alabama Press, 2006), 11.

¹⁶²Janes, “Cruise Missile Definition,” *Jane’s Strategic Weapon Systems*, 1.

elements alone increase the chances of a cruise missile being “hidden by the curvature of the earth or behind hills during parts of the flight,” making it more difficult to stop.¹⁶³

These advantages have probably demonstrated to potential NATO adversaries the uniqueness of cruise missiles and the multitude of benefits that they offer. If NATO is to remain militarily strong, the allies must come to grips with this ever-changing security environment, and by revise their military and operational doctrine to deal with this foreseen threat. As foreign countries continue their push for these strategic weapons—the same weapons that have been used by NATO over the last two decades to prepare the battlefield, penetrate and suppress enemy air defense systems, and destroy key infrastructures—it is reasonable to say that adversaries could use these weapons against the Alliance and severely stress its defensive systems. According to Dennis Gormley, once cruise missiles become “widespread and [a] dominant feature of military operations in the twenty-first century, the strategic consequences for international security could be profound.”¹⁶⁴

¹⁶³*Ibid.*

¹⁶⁴Dennis M. Gormley, “Dealing with the Threat of Cruise Missiles,” Adelphi paper 339 (New York: Oxford University Press, 2001), 7.

THIS PAGE INTENTIONALLY LEFT BLANK

VI. CONCLUSION

This thesis has investigated the significance of airpower in NATO operations, particularly long-range precision-strike cruise missiles. Since its initial debut in the early 1990s, the modern cruise missile has continued to be a major driving force for NATO in crisis management and conflict prevention roles. Though employed in a limited fashion, cruise missiles have become a core competency for the NATO Alliance. The prime examples revealed by the aforementioned operations—Operation Deliberate Force, Operation Allied Force, and Operation Unified Protector—illustrate how the use of cruise missiles can achieve strategic goals, and bring an adversary to the bargaining table.

The importance of cruise missiles for NATO is likely to persist. Cruise missiles have been employed considerably to assist in preparing the battlefield, without putting individual forces at risk. Additionally, cruise missiles, whether launched from a warship or a submarine, are able to travel long distances at very low altitudes and hit a precise target at any given time without being detected. As military establishments continue to cut back on forces, as economic woes continue for not only NATO, but also other nations, reliance upon these strategic weapons may nonetheless increase.

This thesis has highlighted several issues affecting cruise missiles and the NATO Alliance. First and foremost, given the success of cruise missiles, it should not come as a surprise that these advanced weapons are not only the weapon of choice for NATO in certain types of contingencies, but also for militaries worldwide. The proliferation of cruise missiles should be of concern to the NATO Alliance, as many other countries are developing or have developed precision strike weaponry. The spread of these weapons could drastically increase regional threats and prevent challenges for international peace and security. The NATO allies must confront these significant challenges and revise their military and operational doctrine to deal with this foreseen threat.

Lastly, the aforementioned operations have highlighted a growing capabilities gap between the United States and its European allies, which needs addressing immediately. Presently, NATO's European members lack the many capabilities required to protect their own borders, which has in essence required them to rely heavily on the United States for support. Outside of the ability to employ TLAM cruise missiles (a capability of the United Kingdom alone in Europe), NATO's European members lack other essential operational capabilities (validated intelligence, command and control, logistic support, etc.). If the gap is not addressed, NATO stands a realistic chance of not being successful in future operations without the support of the United States. The NATO European allies must take a greater share of the burden and shoulder a greater degree of responsibility for security in Europe.

Despite these two major issues, there is no doubt that cruise missiles will continue to be an effective tool in NATO's military arsenal. The aforementioned operations have vindicated the promise of cruise missiles, and have seemingly demonstrated the vital role that these weapons will play in the future. Though it may be considered unwise to predict the future, it is difficult to foresee NATO conducting future wars without employing cruise missiles. However, as the United States continues its pivot toward the Asia-Pacific region, the U.S. ability to provide additional capabilities to support NATO operations may become unavailable. The United States should therefore maintain its international partnerships and reorganize its military forces to assist its allies in future operations.

LIST OF REFERENCES

- Baltrusaitis, Daniel F., and Mark E. Duckenfield. "Operation Unified Protector: Triumph or Warning Sign." *Baltic Security and Defence Review* 14, no. 2 (2012): 21–47.
- Barrie, Douglas. "Libya's Lessons: The Air Campaign," *Survival* 54, no. 6 (December 2012–January 2013): 57–65.
- Beale, Michael O. *Bombs Over Bosnia: The Role of Airpower in Bosnia-Herzegovina*. Maxwell Air Force Base, Alabama: Air University Press, 1997.
- Bellamy, Alex J., and Paul D. Williams. "The New Politics of Protection? Cote d'Ivoire, Libya and the Responsibility to Protect." *International Affairs* 87, no. 4 (2011): 825–850.
- Betts, Richard K. *Cruise Missiles: Technology, Strategy, Politics and The Origin of the Strategic Cruise Missile*. Washington, DC: The Brookings Institution, 1981.
- . *Cruise Missiles and U.S. Policy*. Washington, DC: The Brookings Institution, 1982.
- Biden Jr., Joseph R. quoted in Thom Shanker, and Eric Schmitt. "Seeing Limits to 'New Kind of War in Libya.'" *The New York Times*. October 21, 2011. Last accessed August 20, 2013. http://www.nytimes.com/2011/10/22/world/africa/nato-war-in-libya-shows-united-states-was-vital-to-toppling-qaddafi.html?_r=3&.
- Bolkcom, Christopher, and Sharon Squassoni. "Cruise Missile Proliferation." Washington DC: Congressional Research Service, 2002.
- Borghard, Erica D., and Costantino Pischedda. "Allies and Airpower in Libya." *Parameters* 42, no. 1 (Spring 2012): 63–74.
- Byman, Daniel L., and Matthew C. Waxman. "Kosovo and the Great Air Power Debate." *International Security* 24, no. 4 (Spring 2000).
- Cimbala, Stephen J., and Peter K. Forster. *Multinational Military Intervention: NATO Policy, Strategy, and Burden Sharing*. Burlington, VT: Ashgate Publishing Limited, 2010.
- Clark, Wesley K. *Waging Modern War: Bosnia, Kosovo, and the Future of Combat*. New York: Public Affairs, 2001.

- Clarke, Michael. "The Making of Britain's Libya Strategy." in Adrian Johnson, and Saeed Mueen, eds. "Introduction." *Short War, Long Shadow: The Political and Military Legacies of the 2011 Libya Campaign*. London: Royal United Services Institute for Defence and Security Studies, 2012).
- CNN World. "How a Fruit Seller Caused Revolution in Tunisia." January 16, 2011. Last accessed February 3, 2014.
<http://www.cnn.com/2011/WORLD/africa/01/16/tunisia.fruit.seller.bouazizi/>
- Cordesman, Anthony H. *The Lessons and Non-Lessons of the Air and Missile Campaign in Kosovo*. Westport: Praeger Publishers, 2001.
- Conrow, E. H., G.K. Smith, and A.A. Barbour. *The Joint Cruise Missiles Project: An Acquisition History*. Santa Monica: RAND Corporation, 1982.
- Daalder, Ivo H., and James G. Stavridis. "NATO's Victory in Libya: The Right Way to Run an Intervention." *Foreign Affairs* 91, no. 2 (March–April 2012): 1–7.
- Daalder, Ivo H., and Michael E. O'Hanlon. *Winning Ugly: NATO's War to Save Kosovo*. Washington, DC: The Brookings Institution, 2000.
- Department of Defense. "The War in Bosnia, 1992–1995." Office of the Historian. Last accessed February 4, 2014.
<https://history.state.gov/milestones/1993–2000/bosnia>.
- . "The Security and Defense Agenda (Future of NATO). Speech delivered by Secretary of Defense Robert M. Gates on June 10, 2011.
<http://www.defense.gov/speeches/speech.aspx?speechid=1581>.
- Dittmer, David, and Stephen P. Dawkins. *Deliberate Force: NATO's First Extended Air Operation: The View from AFSOUTH*. Alexandria: Center for Naval Analyses, 1998).
- Engelbrekt, Kjell, Marcus Mohlin, and Charlotte Wagnsson. *The NATO Intervention in Libya: Lessons Learned From the Campaign*. New York: Routledge Publisher, 2014.
- Feickert, Andrew. "Cruise Missile Proliferation." Washington DC: Congressional Research Service, 2005.
- Friedman, George, and Meredith Friedman. *The Future of War: Power, Technology and American World Dominance in the Twenty-First Century*. New York: St. Martin's Griffin, 1998.
- Gertler, Jeremiah. "Operation Odyssey Dawn (Libya): Background and Issues for Congress." *Congressional Research Service*, (2011).

- Gillespie, Paul G. *Weapons of Choice: The Development of Precision Guided Munitions*, Tuscaloosa: The University of Alabama Press, 2006.
- Gaub, Florence. "The North Atlantic Treaty Organization and Libya: Reviewing Operation Unified Protector." *The Letort Papers*. Carlisle: Strategic Studies Institute U.S. Army War College, 2013.
- Gormley, Dennis M. "Dealing with the Threat of Cruise Missiles." *Adelphi paper* 339. New York: Oxford University Press, 2001.
- Hendrickson, Ryan C. *Diplomacy and War at NATO: The Secretary General and Military after the Cold War*. Columbia: University of Missouri Press, 2006.
- . "Crossing the Rubicon." *NATO Review*. 2005.
- Hosmer, Stephen T. *The Conflict Over Kosovo: Why Milosevic Decided to Settle When He Did*. Santa Monica, CA: RAND Corporation, 2001.
- House Armed Services Committee. "Statement of Admiral Samuel J. Locklear, U.S. Navy, Commander, U.S. Pacific Command Before the House Armed Services Committee on U.S. Pacific Command Posture." March 5, 2013.
- Huisken, Ronald. *The Origin of the Strategic Cruise Missile*. New York: Praeger Publishers, 1981.
- Janes. "Tomahawk Land Attack Missile." *Jane's Strategic Weapon System*. Last accessed September 5, 2013.
<https://janes.ihs.com.libproxy.nps.edu/Grid.aspx>.
- . "Cruise Missile Definition," *Jane's Strategic Weapon Systems*.
- . "Report Reveals Details of Taiwan's Mach 3 Cruise Missile."
- . "RGM/UGM-109 Tomahawk." *Jane's Strategic Weapon System*. Last updated March 27, 2013.
- . "Russia Developing Hypersonic Naval Cruise Missiles."
- . "Germany Takes Delivery of 600th Taurus KEPD 350 Missile."
- . "MdCN Cruise Missile Begins Qualification Trials."
- . "UK, France Kick Off Joint Studies for Next-Generation Anti-Ship/Cruise Weapon."
- Johnson, Adrian, and Saeed Mueen, eds. *Short War, Long Shadow: The Political and Military Legacies of the 2011 Libya Campaign*. London: Royal United Services Institute for Defence and Security Studies, 2012).

- Joint Pub 1–02. *Department of Defense Dictionary of Military and Associated Terms 1998*.
- Hallams, Ellen, and Benjamin Schreer. “Towards a ‘post-American alliance?: NATO burden-sharing after Libya.” *International Affairs* 88, no. 2 (2012): 313–327.
- Hamilton, Daniel S. ed. *Transatlantic Transformations: Equipping NATO for the 21st Century*. Washington, DC: Center for Transatlantic Relations, 2004.
- Hans M. Kristensen. “U.S. Navy Instruction Confirms Retirement of Nuclear Tomahawk Cruise Missile.” FAS Strategic Security Blog from the Federation of American Scientists. Last accessed February 17, 2014. <http://blogs.fas.org/security/2013/03/tomahawk/>.
- Human Rights Watch. “Libya: Governments Should Demand End to Unlawful Killings.” February 20, 2011. Last accessed January 27, 2014. <http://www.hrw.org/news/2011/02/20/libya-governments-should-demand-end-unlawful-killings>.
- Kometer, Michael W., and Stephen E. Wright. *Winning in Libya: By Design or Default?* Focus Stratégique no. 41. Paris: Laboratoire de Recherche sur la Défense, Institut Français des Relations Internationales. January 2013.
- Kopp, Carlo. “Tomahawk Cruise Missile Variants: BGM/RGM/AGM-109 Tomahawk/TASM/TLAM/GCLM/MRASM.” *Technical Report APA-TR-2005–0702*. Last accessed February 14, 2014. <http://www.ausairpower.net/Tomahawk-Subtypes.html>.
- Kosovo/Operation Allied Force After-Action Report to Congress. Washington, DC: U.S. Department of Defense, 31 January 2000.
- Lambeth, Benjamin S. *NATO’s Air War for Kosovo: A Strategic and Operational Assessment*. Santa Monica, CA: RAND Corporation, 2001.
- “Live: Mid-East protests.” BBC News Online. 16 February 2011.
- Mahnken, Thomas G. *Technology and the American Way of War Since 1945*. New York: Columbia University Press, 2008.
- Mishra, Sitakanta “Evolution of the Cruise Missile Discourse: A Conceptual Construct.” *Airpower Journal* 4, no. 1 (Spring 2009): 113–140.
- Missile Threat. “India.” Last accessed September 10, 2013. <http://missilethreat.com/missiles/nirbhay/?country=india#india>.

- . “Iran.” Last accessed September 10, 2013.
<http://missilethreat.com/missiles/meshkat/?country=iran>.
- . “Pakistan.” Last accessed September 10, 2013.
<http://missilethreat.com/missiles-of-the-world/?cruise>.
- . “Tomahawk Variants.” Last accessed on February 27, 2014.
<http://missilethreat.com/missiles/tomahawk-variants/?country=united-states#united-states>.
- Nardulli, Bruce R., Walter L. Perry, Bruce Pirnie, John Gordon IV, and John G. McGinn. *Disjointed War: Military Operations in Kosovo, 1999*. Santa Monica, CA: RAND Corporation, 2002.
- Nelson, C. Richard, and Jason S. Purcell, ed. “Transforming NATO Forces: European Perspectives.” *The Atlantic Council of the United States*. (2002).
- Owen, Robert. “Deliberate Force: A Case Study in Effective Air Campaigning.” Final Report of the Air University Balkans Air Campaign Study. Air University Press, 2000.
- Peters, John E., Stuart E. Johnson, Nora Bensahel, Timothy Liston, and Traci Williams. “European Contributions to Operation Allied Force: Implications for Transatlantic Cooperation.” Santa Monica, CA: RAND Corporation, 2001.
- Pfaltzgraff, Jr., Robert L., and Jacquelyn K. Davis. *The Cruise Missile: Bargaining Chip or Defense Bargain?* Washington, DC: Corporate Press Inc., 1977.
- Pocock, Chris. “NATO’s Role in Ghaddafi’s Downfall: Operation Unified Protector.” *AINonline*. November 13, 2011. Last accessed February 17, 2014. <http://www.ainonline.com/aviation-news/dubai-air-show/2011-11-10/natos-role-ghaddafis-downfall-operation-unified-protector>.
- Reed, John. “Cruise Missiles: Everyone’s Building Them.” *FP National Security*. Last accessed August 21, 2013.
http://killerapps.foreignpolicy.com/posts/2013/07/11/cruise_missiles_every_ones_building_them?wp_login_redirect=0.
- Robertson, George Lord. “Rebalancing NATO for a Strong Future.” Remarks at the Defence Week Conference. Brussels, Belgium. 31 January 2000. Last accessed February 2, 2014.
<http://www.nato.int/docu/speech/2000/s000131a.htm>.
- Roehrig, Terence. “A Changing Paradigm of U.S.-East Asian Relations: Strategic and Economic Perspectives.” Naval War College, National Security Affairs Department. April 2011.

- Report to Congress. "Kosovo/Operation Allied Force After-Action Report."*
January 31, 2000.
- Schake, Kori. "U.S. Retrenchment is Right and Overdue," in Tomas Valasek, ed. *All Alone? What U.S. Retrenchment Means for Europe and NATO*. London: Centre for European Reform, 2012).
- Shanker, Thom, and Eric Schmitt. "Seeing Limits to 'New Kind of War in Libya.'" *The New York Times*. Last accessed August 20, 2013.
http://www.nytimes.com/2011/10/22/world/africa/nato-war-in-libya-shows-united-states-was-vital-to-toppling-qaddafi.html?_r=3&.
- Shukman, David. *Tomorrow's War: The Threat of High-Technology Weapons*. Orlando, FL: Harcourt Brace & Company, 1996.
- Smith, Ben. "Turmoil in the Middle East." *House of Commons Library*. International Affairs and Defence Section. March 28, 2011.
- United Nations. "Security Council Approves 'No-fly Zone' Over Libya, Authorizing 'All Necessary Measures' to Protect Civilians." *Security Council SC/10200*. Last accessed February 13, 2014.
<https://www.un.org/News/Press/docs/2011/sc10200.doc.htm>.
- Webber, Mark, James Sperling, and Martin A. Smith. *NATO's Post-Cold War Trajectory: Decline and Regeneration*. Palgrave: MacMillian Press, 2012.
- Weekly Address. The White House. Office of the Press Secretary. March 26, 2011. Last accessed February 20, 2014. <http://www.whitehouse.gov/the-press-office/2011/03/26/weekly-address-president-obama-says-mission-libya-succeeding>.
- Werrell, Kenneth P. *The Evolution of the Cruise Missile*. Air University: Air University Press, 1985.
- . *Chasing the Silver Bullet: U.S. Air Force Weapons Development from Vietnam to Desert Storm*. Washington, DC: Smithsonian Books, 2003.
- . "The Weapon the Military Did Not Want: The Modern Strategic Cruise Missile." *The Journal of Military History* 53, no.4 (Oct 1989).
- Westervelt, Eric. "NATO's Intervention in Libya: A New Model?" September 12, 2011. Last accessed February 3, 2014.
<http://www.npr.org/2011/09/12/140292920/natos-intervention-in-libya-a-new-model>.
- Yost, David S. *NATO Transformed: The Alliance's New Roles in International Security*. Washington, DC: United States Institute of Peace Press, 1998.

INITIAL DISTRIBUTION LIST

1. Defense Technical Information Center
Ft. Belvoir, Virginia
2. Dudley Knox Library
Naval Postgraduate School
Monterey, California