

# Laser Peening for U.S. Army Helicopters

Contract No. W911NF-06-2-0034

Technology Overview  
Army Research Laboratory  
Aberdeen Proving Ground, MD



Victor Champagne  
Scott Grendahl  
U.S. Army Research Laboratory



Rich Tenaglia  
David Lahrman  
LSP Technologies, Inc.

# Report Documentation Page

Form Approved  
OMB No. 0704-0188

Public reporting burden for the collection of information is estimated to average 1 hour per response, including the time for reviewing instructions, searching existing data sources, gathering and maintaining the data needed, and completing and reviewing the collection of information. Send comments regarding this burden estimate or any other aspect of this collection of information, including suggestions for reducing this burden, to Washington Headquarters Services, Directorate for Information Operations and Reports, 1215 Jefferson Davis Highway, Suite 1204, Arlington VA 22202-4302. Respondents should be aware that notwithstanding any other provision of law, no person shall be subject to a penalty for failing to comply with a collection of information if it does not display a currently valid OMB control number.

1. REPORT DATE <b>JAN 2007</b>		2. REPORT TYPE		3. DATES COVERED <b>00-00-2007 to 00-00-2007</b>	
4. TITLE AND SUBTITLE <b>Laser Peening for U.S. Army Helicopters</b>				5a. CONTRACT NUMBER	
				5b. GRANT NUMBER	
				5c. PROGRAM ELEMENT NUMBER	
6. AUTHOR(S)				5d. PROJECT NUMBER	
				5e. TASK NUMBER	
				5f. WORK UNIT NUMBER	
7. PERFORMING ORGANIZATION NAME(S) AND ADDRESS(ES) <b>U. S. Army Research Laboratory, Aberdeen Proving Ground, MD, 21005</b>				8. PERFORMING ORGANIZATION REPORT NUMBER	
9. SPONSORING/MONITORING AGENCY NAME(S) AND ADDRESS(ES)				10. SPONSOR/MONITOR'S ACRONYM(S)	
				11. SPONSOR/MONITOR'S REPORT NUMBER(S)	
12. DISTRIBUTION/AVAILABILITY STATEMENT <b>Approved for public release; distribution unlimited</b>					
13. SUPPLEMENTARY NOTES <b>27th Replacement of Hard Chrome and Cadmium Plating Program Review Meeting, January 23-25, 2007, New Orleans, LA. Sponsored by SERDP/ESTCP.</b>					
14. ABSTRACT					
15. SUBJECT TERMS					
16. SECURITY CLASSIFICATION OF:			17. LIMITATION OF ABSTRACT	18. NUMBER OF PAGES	19a. NAME OF RESPONSIBLE PERSON
a. REPORT	b. ABSTRACT	c. THIS PAGE			
<b>unclassified</b>	<b>unclassified</b>	<b>unclassified</b>	<b>Same as Report (SAR)</b>	<b>21</b>	

**Laser Shock Peening** is an innovative process for introducing deep compressive residual stresses into the surface of metallic parts

## Material Property Improvements Include Increased:

- Fatigue strength and fatigue life
- Resistance to crack initiation and propagation
- Resistance to fretting fatigue and wear
- Resistance to stress corrosion cracking

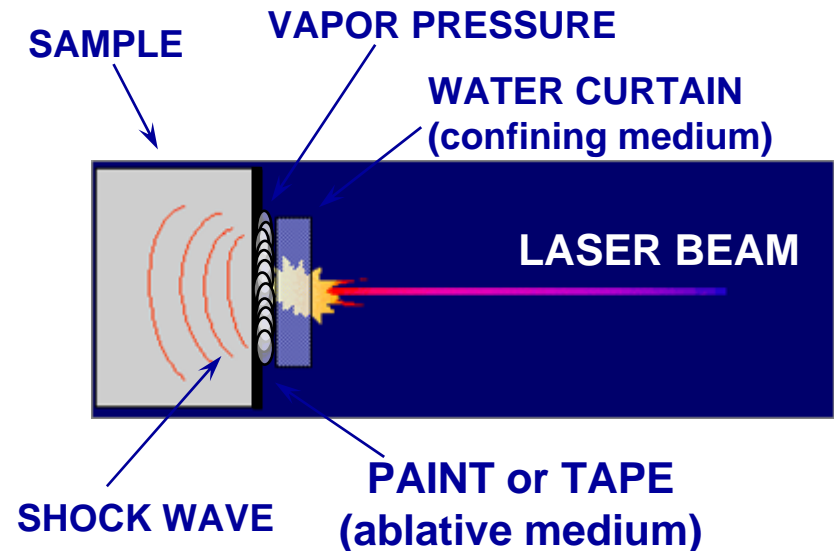

Laser peening is not a thermal treatment; it creates deep compressive residual stresses in the surface of a part with a shock wave created by high intensity laser pulses that mechanically cold-work the surface.

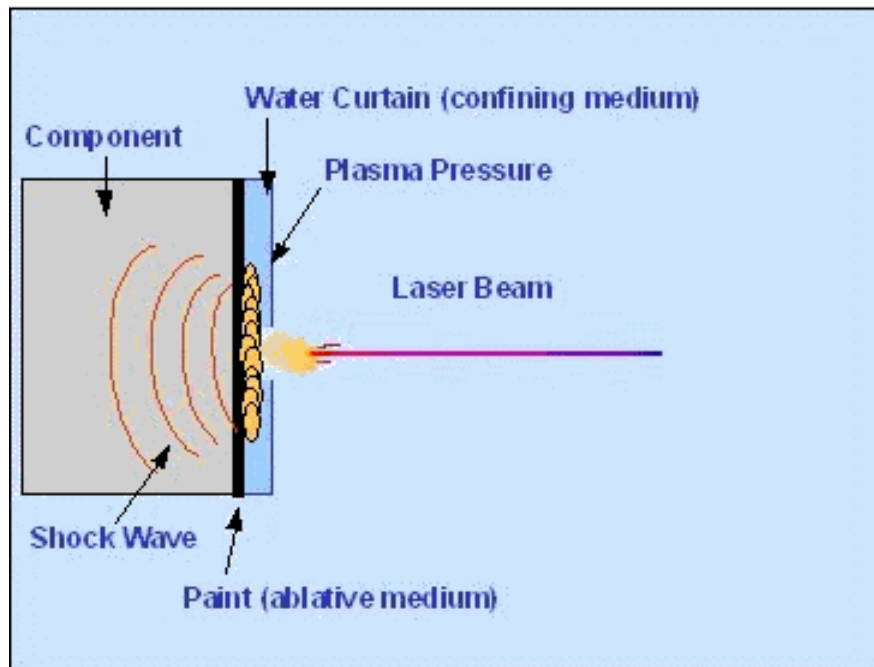

Before processing, an opaque overlay (typically black paint or tape) and a transparent overlay (typically flowing water) are applied to the surface to be laser peened.

The laser pulse passes through the transparent overlay and strikes the opaque overlay causing it to begin to vaporize. The vapor absorbs the remaining laser light and produces a rapidly expanding plasma plume.

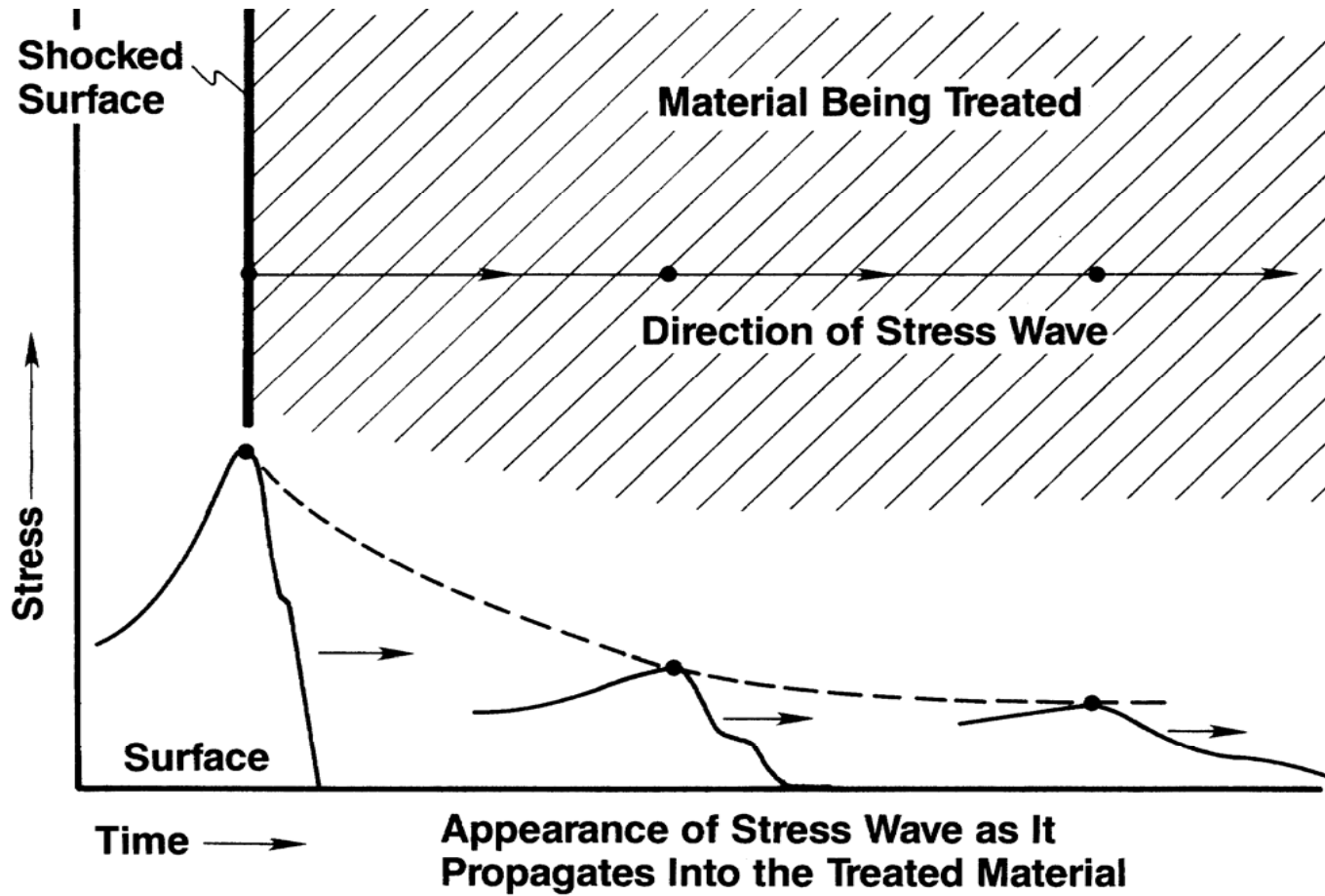

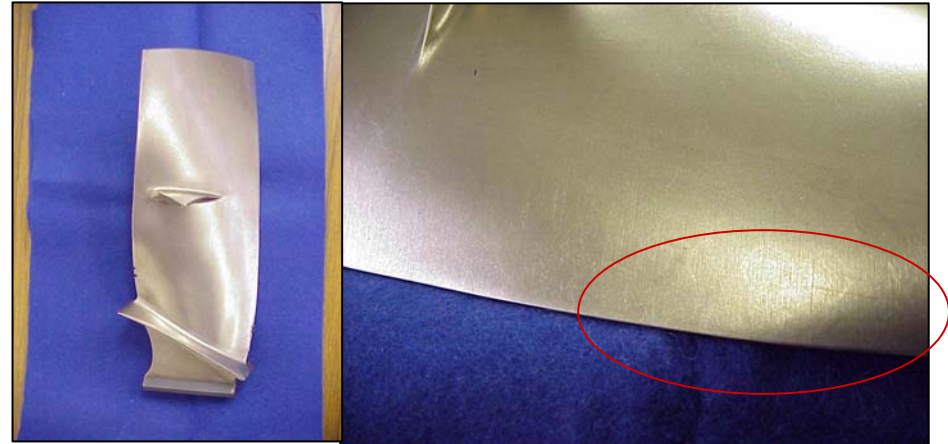
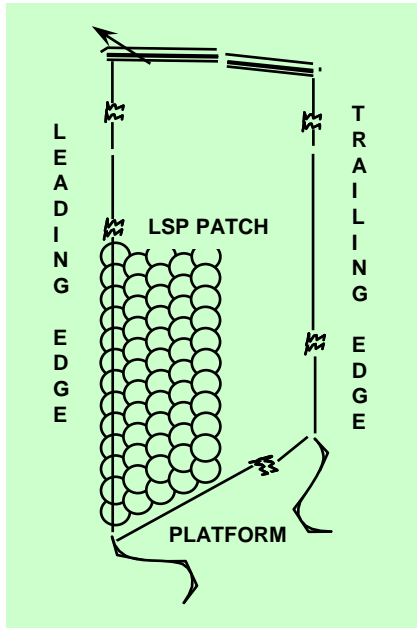

- A pattern of laser pulses results in an area of deep compressive stress
- Results of industry and government testing shows that laser peening stops or significantly inhibits crack initiation and propagation in blades





# DoD ManTech Manufacturing Cell Laser System



**Nd:Glass Laser System – Two Beams at up to 50 Joules Per Beam**



*Small Parts Peening Cell  
(Turbine Airfoils)*



*Large Parts Peening Cell  
(Integrally Bladed Rotors)*

**MC Laser System (2-beam) Operates at 1.25 Hz (every 0.8 seconds)**



# Residual Stresses

## Laser Peening versus Shot Peening

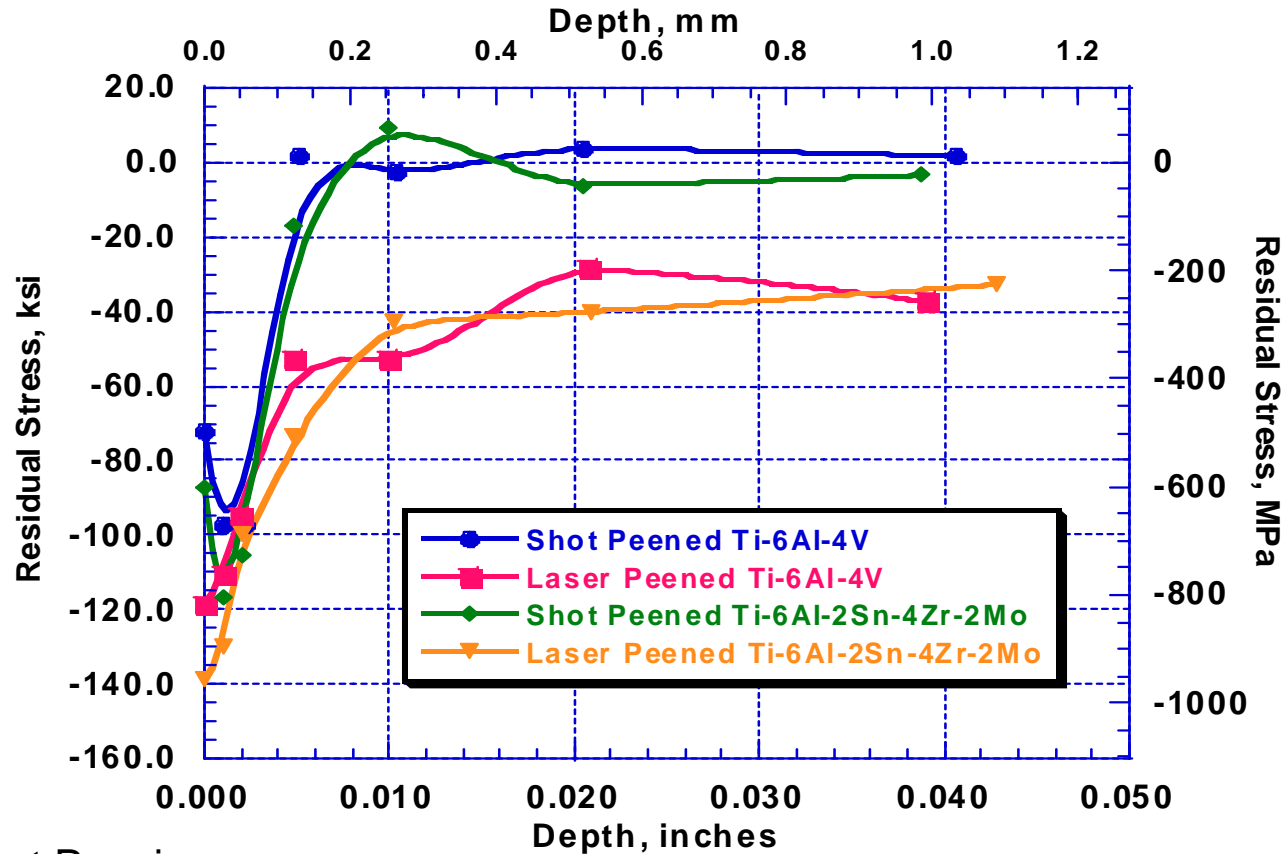

Shot Peening

—Residual Stress depth ~0.1 mm (0.004 inches)

Laser Peening

—Residual Stress depth 1 to 1.5 mm (0.040 to 0.060 inches)



# Testing Results of Fan Blades after Simulated FOD

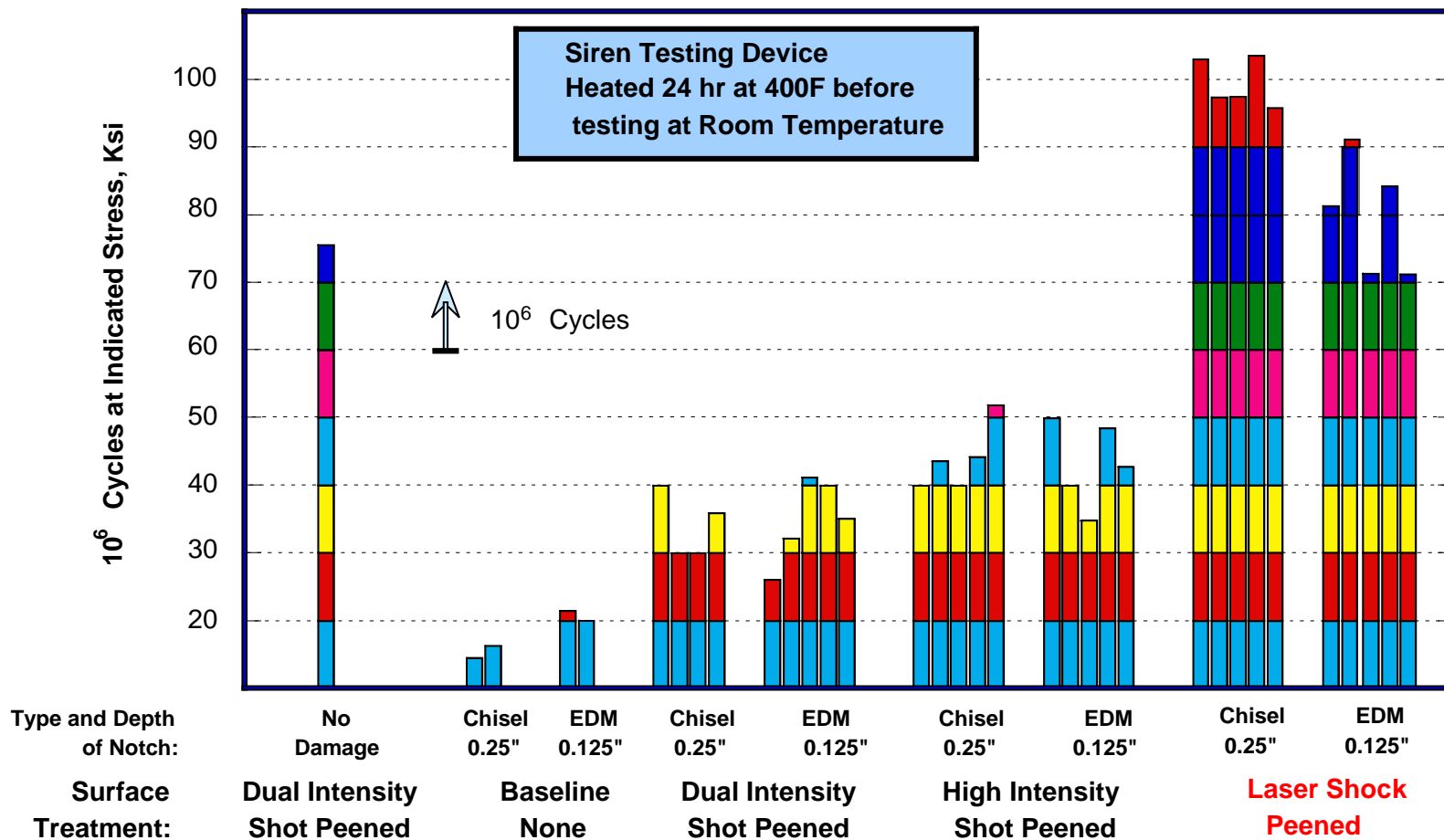

After See, Thompson and Sampson, Air Force Research Laboratory, USAF



# F119 IBRs

## Improved Fatigue Strength and Damage Tolerance



- Laser peening increases notched fatigue strength of IBR airfoils above the fatigue strength design criteria
- Initiative established the first production-ready IBR Peening Cell

Effect of Laser Peening on F119 IBR Fatigue Life

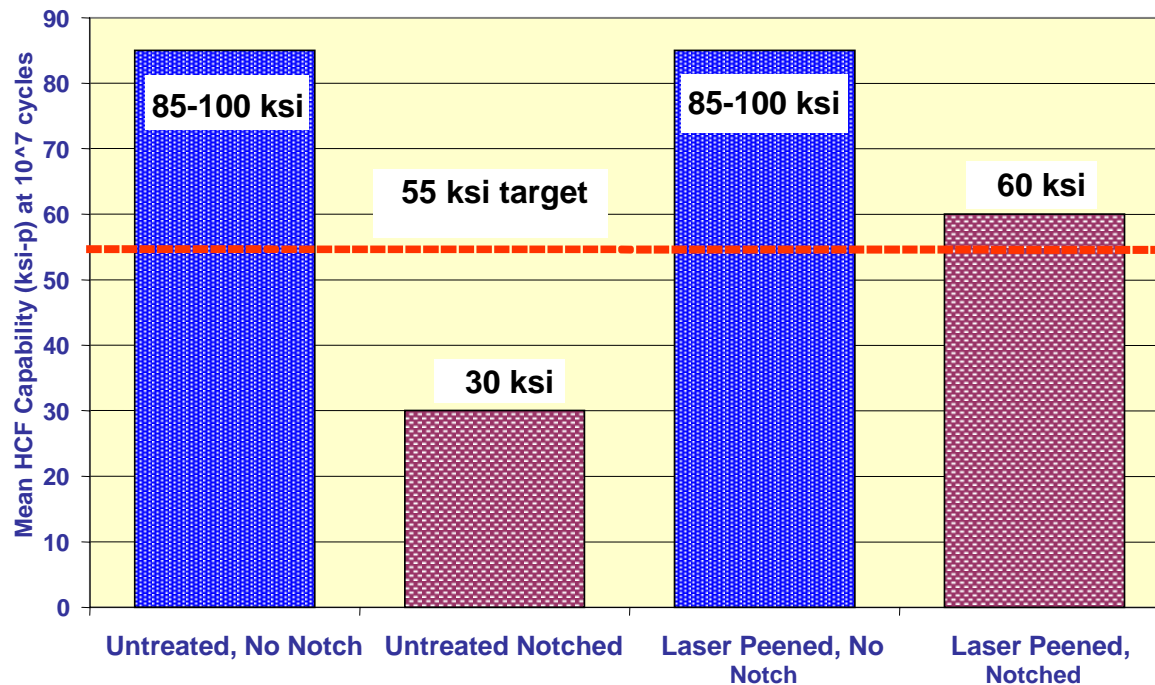

**Increased notched\* fatigue strength and FOD resistance on laser peened F119 IBRs**

\* EDM Notch 0.050-inches deep



# Fatigue Properties

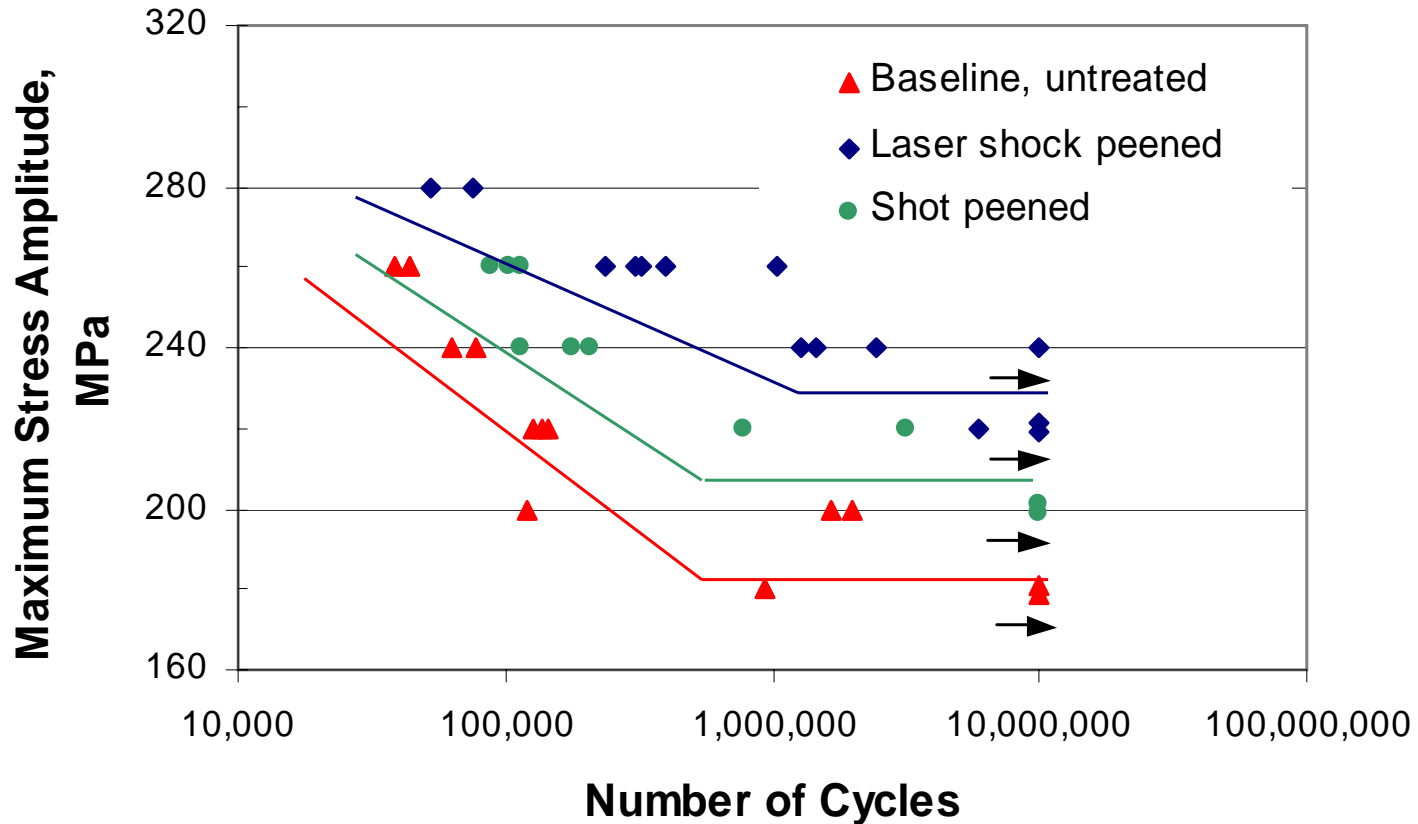

## 7050-T351 Aluminum

4 GW/cm<sup>2</sup>

3-point bending, R=0.1, Notched:  $K_t=1.68$

After P. Peyre, et.al.



# Fretting Fatigue Results

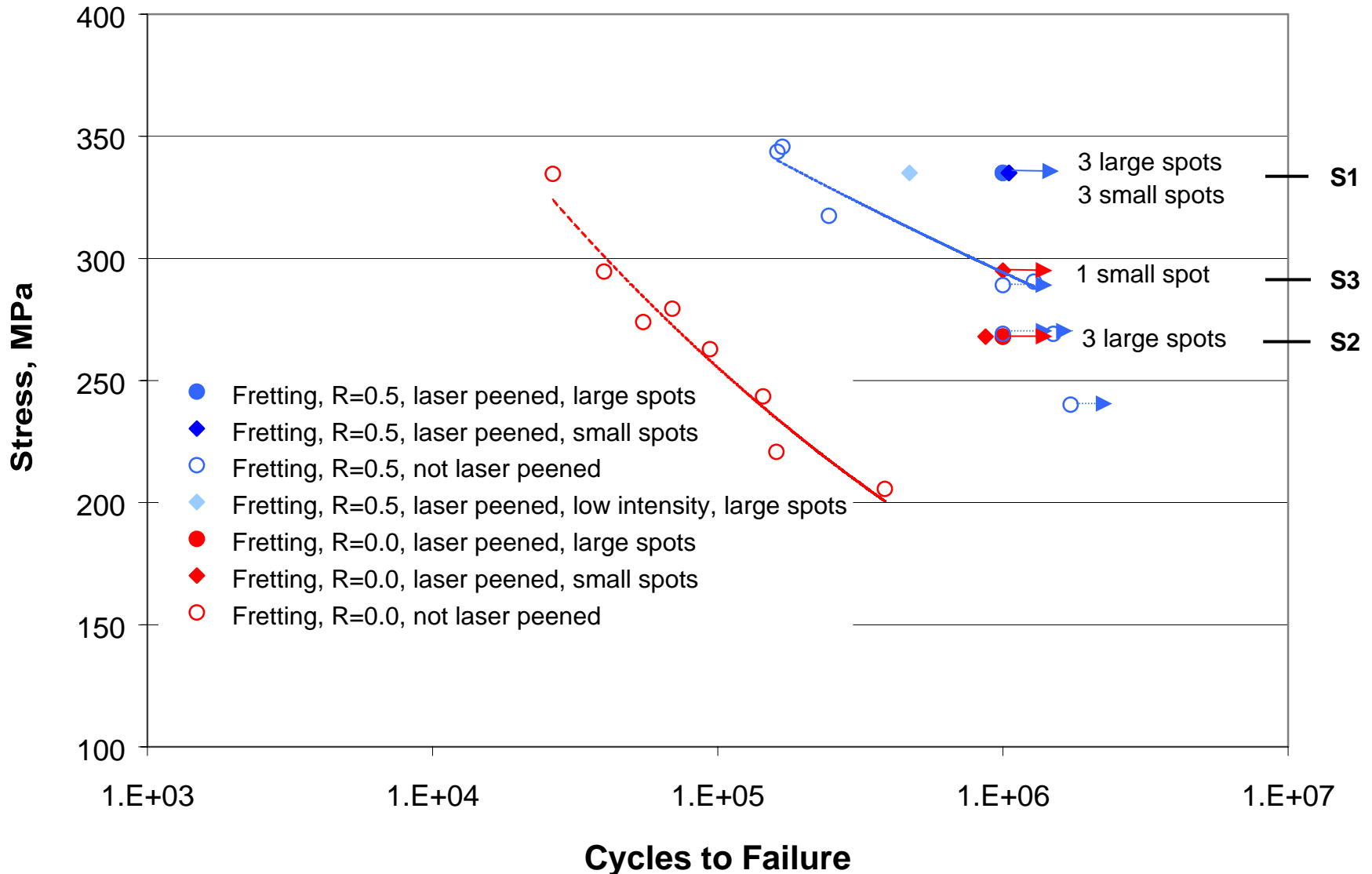

# Evolution of Laser Peening Production Applications



*B1-B Lancer, F101-GE-102 Engine*



*F/A-22 Raptor, F119-PW-100 Engine*



*F-16 Falcon, F110-GE-100,129 Engines*



# Laser Peening of Army Aviation Applications



*Apache*



*Chinook*



*Blackhawk*

**Tougher Drive Systems for Higher HP Helicopter Versions  
Needed for High Altitude Missions such as Afghanistan**



- **Chinook Transmissions**
  - Engine - Gear tooth root
  - Forward - Planetary gears
  - Aft - Spiral bevel gear
- **Apache**
  - Main rotor transmission shaft – Upper and lower splines

# Application Development Projects



**ARL/Penn State & Gear Research Institute – Gear testing program underway to evaluate laser peening effects on gear bending fatigue.**



**Boeing Helicopters - Investigating effects of laser peening for CH-47 horizontal hinge pins**



*Bell 430 helicopter*



*2nd-3rd Stage IBR*

**Rolls-Royce – Investigating laser peening to prevent fatigue failures originating at corrosion pits.**



## LaserPeen<sup>®</sup> Processing of F110-100 Turbine Engine Blade Using the RapidCoater<sup>™</sup> System

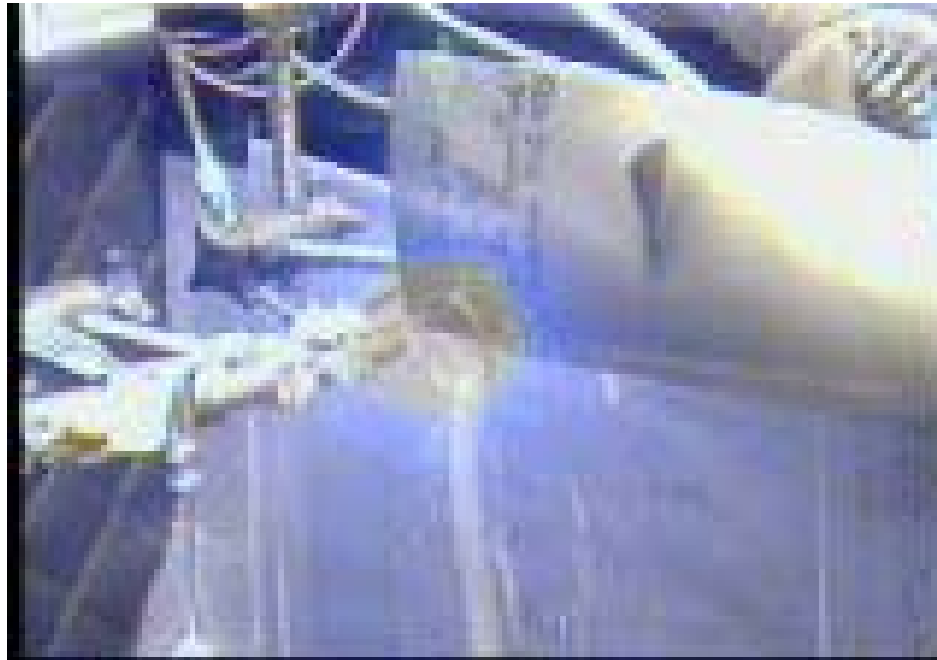

**LSPT's automated RapidCoater<sup>™</sup> system reduces the processing time from ~33 minutes (with tape) to less than 6 minutes!**



**F-16 Falcon**

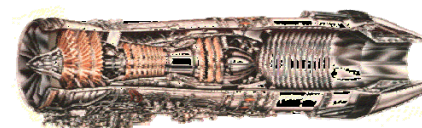

**F110 Engine**

# Laser Peening of Hidden Surfaces

## New Growth Area

### Issue with Current Systems

- Dovetail slots have limited line-of-sight access (hidden surfaces) due to high aspect ratio (slot length to width)

### Approach

- Reduce laser beam size
- Use the similar power densities to generate deep compressive stresses
- Deliver laser beam through articulated arm to processing pen

### Benefits

- Reduced laser system costs
- Smaller laser system footprint
- Provides improved fretting fatigue resistance

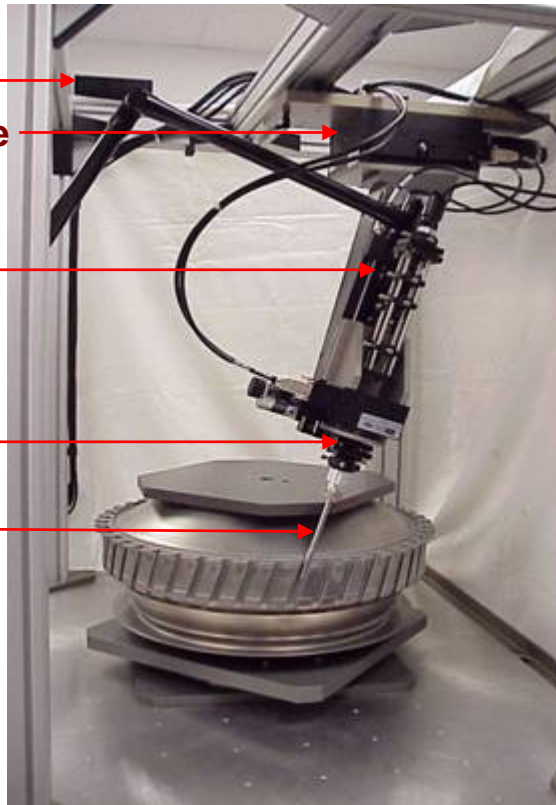
- 
- Articulated Arm
  - XY Translation Stage
  - Z Translation Stage
  - Rotary Stage
  - Processing Pen

Demonstrated laser peening on F110-GE-400 2<sup>nd</sup> stage fan disk with prototype system



# Laser Peening of Dovetail Slots

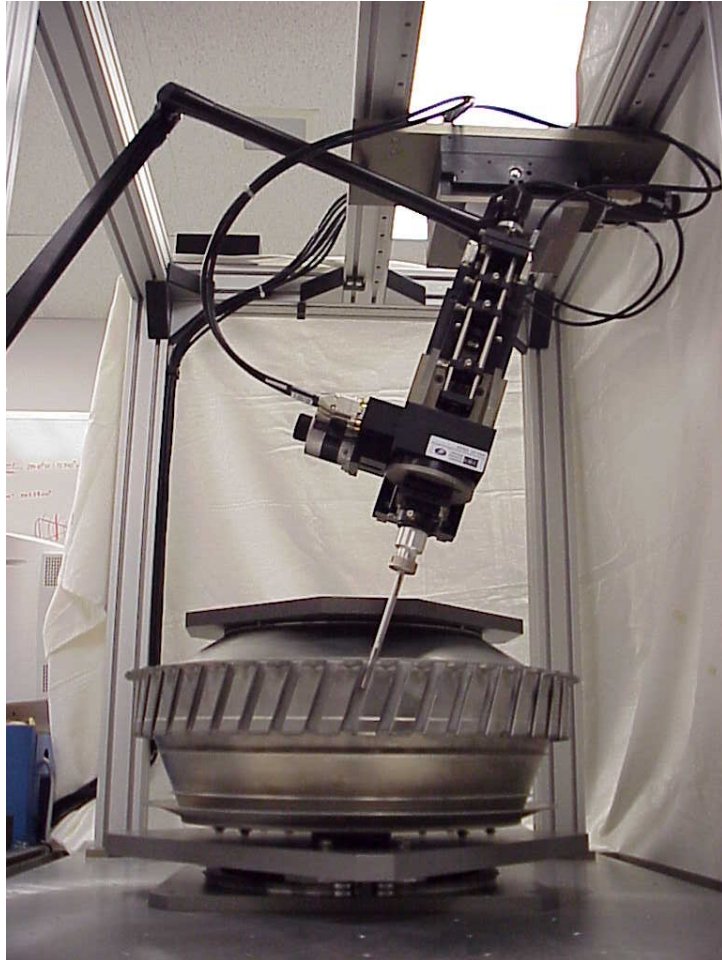



# Laser Peening of Hidden Surfaces AF SBIR II Enhancement Program



## Contract No. FA8650-05-C-5303

**Program Goal:** Develop a pre-production laser peening system based on a commercially-available, high-repetition-rate laser system using LSPT's small spot processing approach and articulated arm beam delivery.

**Additional Benefit:** Small-scale system components can be integrated into a portable unit for deployment at AF repair depots in a follow-on engineering effort once high-repetition-rate laser peening is validated.

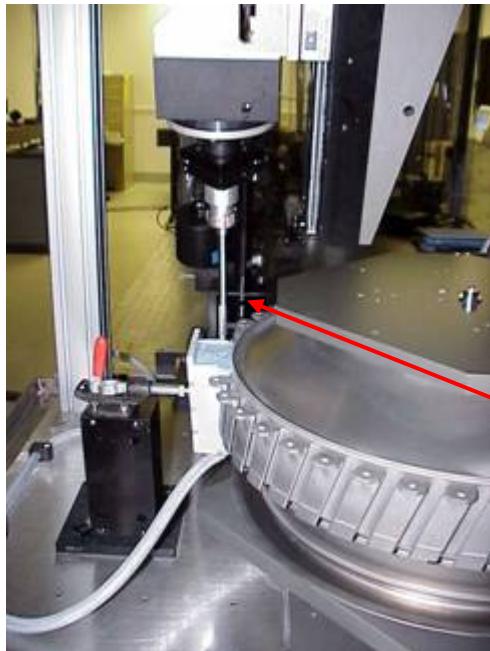

Processing pen



Continuum 9050 small-spot,  
high-repetition-rate laser  
system

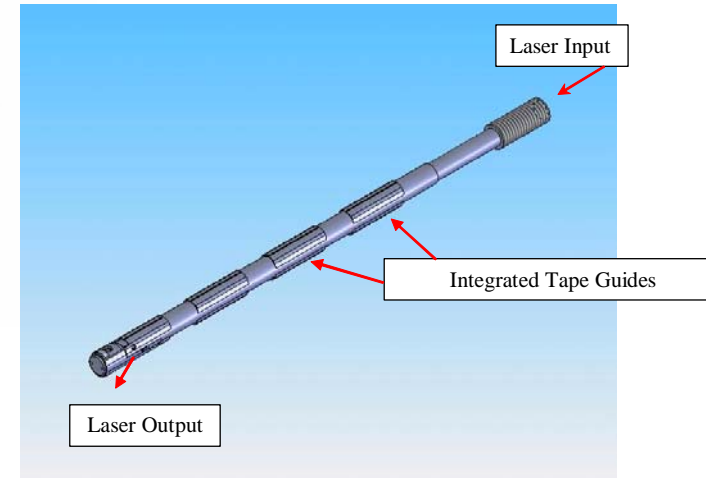

Processing pen schematic for  
laser peening recessed areas



**Boeing 787**



**Boeing UCAV X-45**

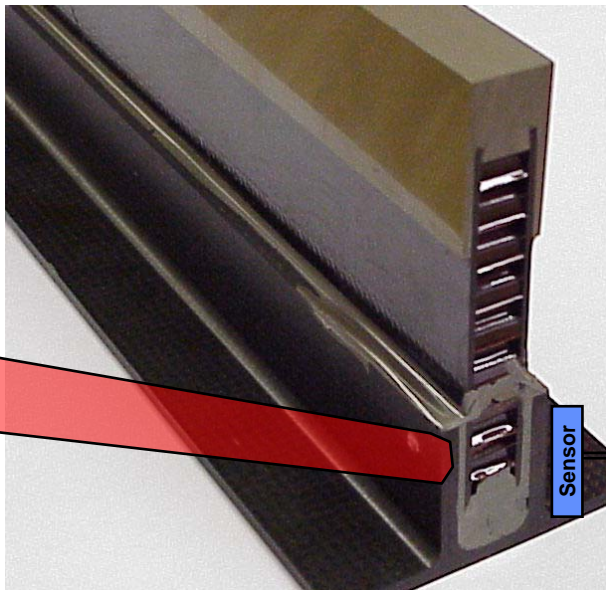

**Inspecting to Ensure Bond Strength**



# Burst Laser System for Standoff Mine Neutralization



10-kW continuous laser works, but is slow and not mobile

10-kW pulsed burst laser is much more efficient and will be mobile

