

HVOF Hard Chrome Alternatives: Developments, Implementation, Performance and Lessons Learned

Location: Denver, CO

Date: 2 September 2009

Presenter: Ben Evans, M&PT, Goodrich Landing Gear

Report Documentation Page

Form Approved
OMB No. 0704-0188

Public reporting burden for the collection of information is estimated to average 1 hour per response, including the time for reviewing instructions, searching existing data sources, gathering and maintaining the data needed, and completing and reviewing the collection of information. Send comments regarding this burden estimate or any other aspect of this collection of information, including suggestions for reducing this burden, to Washington Headquarters Services, Directorate for Information Operations and Reports, 1215 Jefferson Davis Highway, Suite 1204, Arlington VA 22202-4302. Respondents should be aware that notwithstanding any other provision of law, no person shall be subject to a penalty for failing to comply with a collection of information if it does not display a currently valid OMB control number.

1. REPORT DATE 02 SEP 2009		2. REPORT TYPE		3. DATES COVERED 00-00-2009 to 00-00-2009	
4. TITLE AND SUBTITLE HVOF Hard Chrome Alternatives: Developments, Implementation, Performance and Lessons Learned				5a. CONTRACT NUMBER	
				5b. GRANT NUMBER	
				5c. PROGRAM ELEMENT NUMBER	
6. AUTHOR(S)				5d. PROJECT NUMBER	
				5e. TASK NUMBER	
				5f. WORK UNIT NUMBER	
7. PERFORMING ORGANIZATION NAME(S) AND ADDRESS(ES) UTC Aerospace Systems (formerly Goodrich),8000 Marble Avenue,Cleveland,OH,44105				8. PERFORMING ORGANIZATION REPORT NUMBER	
9. SPONSORING/MONITORING AGENCY NAME(S) AND ADDRESS(ES)				10. SPONSOR/MONITOR'S ACRONYM(S)	
				11. SPONSOR/MONITOR'S REPORT NUMBER(S)	
12. DISTRIBUTION/AVAILABILITY STATEMENT Approved for public release; distribution unlimited					
13. SUPPLEMENTARY NOTES ASETSDefense 2009: Sustainable Surface Engineering for Aerospace and Defense Workshop, August 31 - September 3, 2009, Westminster, CO. Sponsored by SERDP/ESTCP.					
14. ABSTRACT					
15. SUBJECT TERMS					
16. SECURITY CLASSIFICATION OF:			17. LIMITATION OF ABSTRACT Same as Report (SAR)	18. NUMBER OF PAGES 13	19a. NAME OF RESPONSIBLE PERSON
a. REPORT unclassified	b. ABSTRACT unclassified	c. THIS PAGE unclassified			

- **Hard chrome plating has been used on landing gear for wear applications for over 50 years and provides a hard, smooth, abrasion-resistant surface with some corrosion protection.**
- **Hard chrome has been used on highly loaded, fatigue critical landing gear components such as pistons, axles, and pins.**



- Replacement of chrome was driven by OSHA and EPA requirements, and end customer requirements for new designs
- In 1996, the Hard Chrome Alternatives Team (HCAT) was initiated to study chrome replacement
- HCAT testing included both specimen testing and component testing for both commercial and military applications.
- High Velocity Oxygen Fuel (HVOF) became the coating process of choice to replace hard chrome on landing gear.
- From HCAT, 2 coatings were selected for landing gear applications:
 - >Tungsten Carbide-Cobalt (88%WC-12%Co)
 - >Tungsten Carbide-Cobalt-Chrome (84%WC-12%Co-4%Cr)

- **Goodrich performed 3 tests for the HCAT:**
 - **Fatigue of entire Dash 8 main landing gear**
 - **High cycle (dithering) wear test on hydraulic actuators**
 - **Bending fatigue test on 5" and 10" coated pistons**

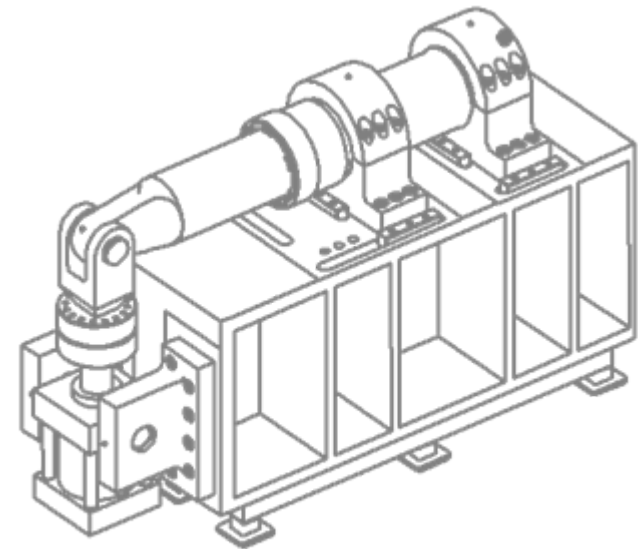
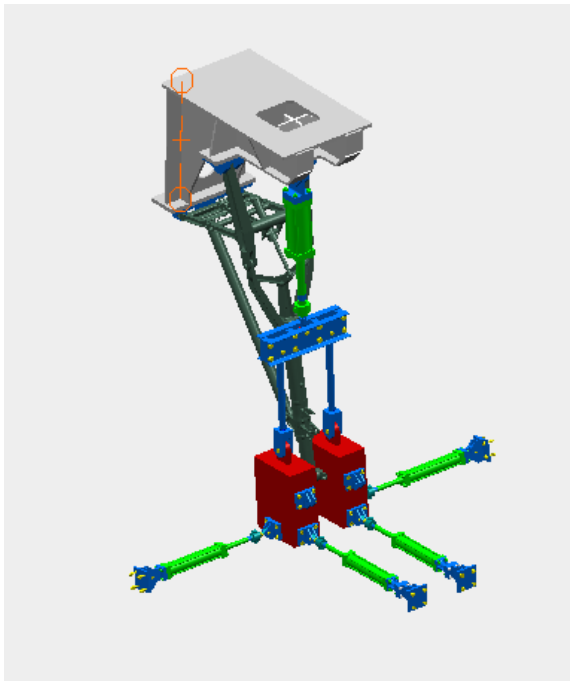

ISOMETRIC VIEW

Summary of HCAT Results:

Compared with hard chrome..

- 1. WC-Co and WC-Co-Cr HVOF coatings have equal or better corrosion
- 2. WC-Co and WC-Co-Cr coatings have equal or better fatigue properties.
- 3. With correct surface finishes WC-Co-Cr coatings have superior wear properties.

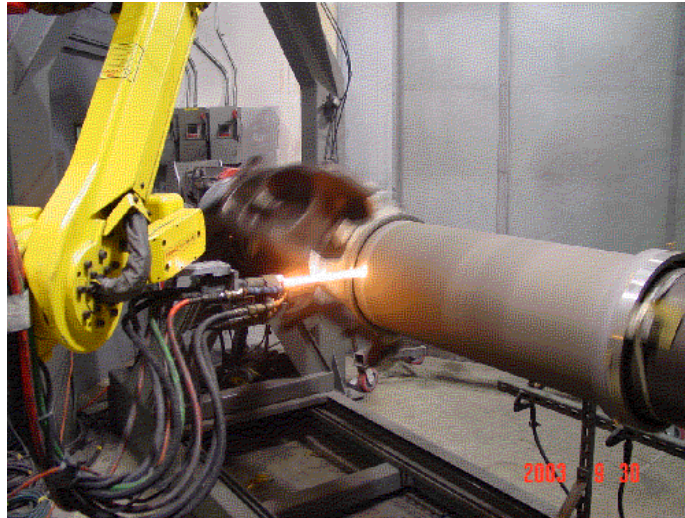

- The Airbus A380 design was the first Goodrich Landing Gear with a HVOF coating as a hard chrome replacement for line of sight applications.
- The introduction of HVOF led to:
 - > the development of new proprietary materials and processing specifications,
 - > the development of qualification criteria for suppliers of HVOF spraying, grinding, and inspection
 - > expansion of the use other coatings to replace chrome on IDs



- **Goodrich now uses HVOF applied wear coatings in lieu of hard chrome for line of sight application on new landing gear designs for both military and commercial aircraft.**



- HVOF has also been used selectively on existing designs
- To date the implementation HVOF on new and existing designs has been very successful with no reported performance issues.



Impediments to widespread use of HVOF on new designs include:

- > cost of HVOF versus hard chrome plating**
- > legislation and regulations continues to allow the use hard chrome plating**



- **Issues that have been faced with the introduction of HVOF:**
 - **Development of a supply base that can spray parts, grind and inspect landing gear parts**
 - **Development of suppliers who's capabilities and location support the existing manufacturing supply base.**
 - **Developing expertise for masking, grinding and super finishing coatings to meet drawing requirements**
 - **Machine shops prefer “one stop shop” solution: develop HVOF providers who can perform pre-coating processes such as shot peening and post-coating processes such as cadmium plating are preferred.**

- Continued use of HVOF WC-Co-Cr for new designs
- Continued implementation of HVOF for existing designs
- New coatings for dimensional restoration
- Strain compliant coatings
- Coating non-line of sight surfaces



- **Collaborative working groups such as HCAT can help identify, evaluate and implement new technologies and materials.**
- **Important to understand the new technology will not be the same (e.g. HVOF line of sight, coating spalling, etc.) and that multiple substitutes may be required.**
- **It is important to engage suppliers and processors early in the process to identify product specific issues such configuration and size, base material issues, etc.**
- **Must consider the learning curve for processing parts to requirements.**
- **Do not under-estimate qualification of ancillary processes to new technology, e.g. HVOF masking, HVOF grinding**
- **It is important to engage supply chain early in process to evaluate the affect of the technology change to upstream and downstream processes and to develop suppliers who's capabilities and location support the existing manufacturing supply base.**

Thank You

