

# Naval Surface Warfare Center Carderock Division

Philadelphia, PA 19112-1403

---

NSWCCD-98-TR-2011/32

November 2011

Machinery Research and Engineering Department Technical Report

## Elimination of Acid Cleaning of High Temperature Salt Water Heat Exchangers ESTCP WP-200302

Subtitle: Redesigned Pre-production  
Full-Scale Heat Pipe Bleed Air Cooler For Shipboard Evaluation

By

Denis Colahan

Energy Conversion Directorate

A.L. (Fred) Phillips

Thermacore, Inc.



---

[STATEMENT](#) A:

Approved for Public Release; Distribution Unlimited

---

NSWCCD-98-TR-2011/11

**REPORT DOCUMENTATION PAGE**Form Approved  
OMB No. 0704-0188

Public reporting burden for this collection of information is estimated to average 1 hour per response, including the time for reviewing instructions, searching existing data sources, gathering and maintaining the data needed, and completing and reviewing this collection of information. Send comments regarding this burden estimate or any other aspect of this collection of information, including suggestions for reducing this burden to Department of Defense, Washington Headquarters Services, Directorate for Information Operations and Reports (0704-0188), 1215 Jefferson Davis Highway, Suite 1204, Arlington, VA 22202-4302. Respondents should be aware that notwithstanding any other provision of law, no person shall be subject to any penalty for failing to comply with a collection of information if it does not display a currently valid OMB control number. **PLEASE DO NOT RETURN YOUR FORM TO THE ABOVE ADDRESS.**

<b>1. REPORT DATE (DD-MM-YYYY)</b> 11-Nov-2011		<b>2. REPORT TYPE</b> FINAL		<b>3. DATES COVERED (From - To)</b> 1-Jan-2003 - 1-Oct-2009	
<b>4. TITLE AND SUBTITLE</b> Elimination of Acid Cleaning of High Temperature Salt Water Heat Exchangers ESTCP WP-200302 (formaly PP-0302) Subtitle : Redesigned Pre-Production Full-Scale Heat Pipe Bleed Air Cooler For Shipboard Evaluation				<b>5a. CONTRACT NUMBER</b> N65540-03-C-0065 & N6554-06-C-0022	
				<b>5b. GRANT NUMBER</b>	
				<b>5c. PROGRAM ELEMENT NUMBER</b> 063851D8Z	
<b>6. AUTHOR(S)</b> Denis Colahan Energy Conversion Directorate A.L. (Fred) Phillips Thermacore Inc.				<b>5d. PROJECT NUMBER</b> WP-200302	
				<b>5e. TASK NUMBER</b>	
				<b>5f. WORK UNIT NUMBER</b>	
<b>7. PERFORMING ORGANIZATION NAME(S) AND ADDRESS(ES) AND ADDRESS(ES)</b>  Naval Surface Warfare Center Carderock Division 5001 South Broads St Philadelphia, PA 19112-1403				<b>8. PERFORMING ORGANIZATION REPORT NUMBER</b>  NSWCCD-98-TR-2011/32	
<b>9. SPONSORING / MONITORING AGENCY NAME(S) AND ADDRESS(ES)</b> Office of Secretary of Defense Environmental Security Technology Certification Program 4800 Mark Center Drive, Suite 17D08, Alexandria VA 22350				<b>10. SPONSOR/MONITOR'S ACRONYM(S)</b> ESTCP	
				<b>11. SPONSOR/MONITOR'S REPORT NUMBER(S)</b>	
<b>12. DISTRIBUTION / AVAILABILITY STATEMENT</b> Public Distribution Authorized					
<b>13. SUPPLEMENTARY NOTES</b>					
<b>14. ABSTRACT</b> A conventional Bleed Air Cooler (BAC) uses a shell and tube heat exchanger (HX), in which hot bleed air is fed to the shell side and seawater is fed to the tube side. The high temperature air readily heats the seawater side of much of the tube surfaces to temperatures well in excess of the 150°F temperature at which fouling occurs. This fouling precipitates dissolved solids in the seawater, which forms scaling, i.e. calcareous deposits, on the tube walls. Scaling reduces heat transfer capacity which can affect air temperature and downstream applications. Scaling will result in local temperatures which approach the inlet air temperatures; elevated temperatures accelerate corrosion and wear, which then leads to leakage and catastrophic failures. The use of heat pipes eliminates the direct contact of hot air and seawater across a thin tube wall. Instead, heat is transported from the air side to the seawater side of the HX through a number of heat pipes. Heat pipes use the evaporation and condensation of a working fluid to transport heat. One feature of saturated, two phase heat transport is that the entire inside surface of the heat pipe is very nearly the same temperature. By directly manipulating the relative heat transfer surfaces (i.e. the relative number and size of the fins and the air and water sides of the heat pipe), the surface Temperature on the water side can be maintained below the critical 150°F fouling temperature.					
<b>15. SUBJECT TERMS</b>					
<b>16. SECURITY CLASSIFICATION OF:</b>			<b>17. LIMITATION OF ABSTRACT</b>  SAR	<b>18. NUMBER OF PAGES</b>  300	<b>19a. NAME OF RESPONSIBLE PERSON</b> Denis Colahan
<b>a. REPORT</b> UNCLASSIFIED	<b>b. ABSTRACT</b> UNCLASSIFIED	<b>c. THIS PAGE</b> UNCLASSIFIED			<b>19b. TELEPHONE NUMBER (include area code)</b> 215-897-7231

## Table of Contents

<b>Table of Figures</b> .....	<b>iii</b>
<b>Table of Tables</b> .....	<b>v</b>
<b>Administrative Information</b> .....	<b>vi</b>
<b>Acknowledgments</b> .....	<b>vii</b>
<b>Acronyms</b> .....	<b>viii</b>
<b>Executive Summary</b> .....	<b>ix</b>
<b>Chapter 1 - Introduction</b> .....	<b>1-1</b>
1-1 Background.....	1-1
1-1.1 About the Masker and Prairie - Bleed Air Systems (BAS) .....	1-1
1-1.2 Masker Cooler Problems.....	1-1
1-2 Objectives of the Demonstration.....	1-2
1-2.1 Problem.....	1-2
1-2.2 Solution.....	1-2
1-2.3 Objective.....	1-3
1-3 Regulatory Drivers.....	1-3
<b>Chapter 2 - Technology Description</b> .....	<b>2-1</b>
2-1 Technology Development and Application.....	2-1
<b>Chapter 3 - Technology Development as of November 2011</b> .....	<b>3-1</b>
3-1 Program History.....	3-1
3-2 Summary of Previously Reported Work under base contract N65540-06-C-0022 .....	3-9
3-2.1 Test and Diagnosis .....	3-9
3-2.2 Redesign of HP-BAC .....	3-9
3-2.3 Fabricate and Test Heat Pipes.....	3-10
3-2.4 Design and Fabricate HP-BAC Engineering Test Unit. (25 Pipe Coupon).....	3-10
3-2.5 Testing.....	3-10
3-2.6 Results.....	3-10
3-3 Major Tasks Under the Option 1/Amendment Work of N65540-06-C-0022 .....	3-10
3-3.1 Re-correlate Analytic Model and perform Trade Study .....	3-10
3-3.2 Extend Pipes to Fully Utilize Existing Shells.....	3-10
3-3.3 Design New Ducts and Baffles .....	3-11
3-3.4 Fabricate Full Scale HP-BAC .....	3-11
3-3.5 Land Based Test of Full Scale HP-BAC .....	3-11
<b>Chapter 4 - Re-correlate Analytic Model and Perform Trade Study</b> .....	<b>4-1</b>
4-1 Re-correlate Analytic Model.....	4-1
4-1.1 The Wyle Labs Test and Data.....	4-1
4-1.2 The Analytic Model .....	4-3
4-1.3 Preliminary Analysis.....	4-3
4-1.4 The Analytic Model Recorrelation.....	4-4
<b>Chapter 5 - Extend Heat Pipes to Fully Utilize Existing Shells</b> .....	<b>5-1</b>
5-1 Extended Heat Pipes and Fins.....	5-1
5-2 Baffles for Extended Heat Pipes .....	5-2

5-3 Ducts for Complex Baffles.....	5-3
<b>Chapter 6 - Fabricate Full Scale HP-BAC.....</b>	<b>6-1</b>
6-1 Baffles and Ducts .....	6-1
6-2 Fin Brazing.....	6-2
6-3 Heat Pipe Processing.....	6-7
6-4 Instrumentation .....	6-7
<b>Chapter 7 - Land Based Test of Full Scale HP-BAC .....</b>	<b>7-1</b>
7-1 Thermocouple Placement.....	7-1
7-2 Testing at Stork East-West Technology Corp. ....	7-2
7-2.1 Test Setup.....	7-2
7-2.2 Test Results .....	7-4
7-2.3 Comments about Figure 7-5 through 7-9 .....	7-5
7-3 Reduction and Evaluation of Test Data.....	7-11
7-4 Analytic Model ReCorrelation .....	7-11
7-5 Conclusions and Recommendations.....	7-13
<b>Chapter 8 - References .....</b>	<b>8-1</b>

## Appendices

Appendix A	Finalreport _Design and Fabrication of a Prototype Full-Scale Heat Pipe Bleed Air Cooler HeatExchanger
Appendix A-A	Heat Pipe Colere Tecjnology Demonstration on The DDG-61 USS Ramage
Appendix A-B	Ship Survey Report
Appendix A-C	Heat Pipe Design and Development
Appendix A-D	EWI Welding and Engineering Support Report
Appendix A-E	Structural Design Report
Appendix A-F	Thermal Analysis Models
Appendix B	Post Analysis Report—HeatPipe Bleed Air Cooler Heat Excchanger Contract Contract N65540-06-C-0022
Appendix C	FINAL REPORT – Redesign of Full Scale Heat Pipe Bleed Air Cooler Heat Exchanger
Appendix D	Improved Fin Attachment and Fin Count
Appendix E	Production Cost Analysis
Appendix F	White Paper – Transition Plans For The Heat Pipe – High Temperature Heat Exchanger Technology to The NAVY
Appendix G	NAVICP LECP Analysis – Bleed Air Cooler Heat xchanger Reepacement_Heat Pipe Design, LECP Analysis

## Table of Figures

Figure 2- 1 Current Bleed Air System Shell & Tube Heat Exchanger Design.....	2-1
Figure 2- 2 Heat Pipe Technology .....	2-2
Figure 2- 3 Proposed Full Scale “Heat Pipe” Heat Exchanger .....	2-3
Figure 3- 1 Original Proposed heat pipe cooler before assembly and USS Ramage Install .....	3-2
Figure 3- 2 HP-BAC Installed on USS Ramage, DDG-61 .....	3-3
Figure 3- 3 Original Prototype Full Scale HPBAC with Blow by Areas.....	3-4
Figure 3-4 Showing Post Analysis of Heat Pipe Capabilities in Original HPBAC .....	3-4
Figure 3-5 Various Figures From Page 20 of EWI Report Showing The Silver Brazing of Fins to The Heat Pipes (In Appendix A of this report A full report by EWI on joining is located in Appendix A-D) .....	3-5
Figure 3-6 Fabrication of 25 Pipe Coupon At Thermacore .....	3-6
Figure 3-7 Testing Small coupon at Wyle Labs .....	3-7
Figure 3- 8 Original Fin Braze.....	3-7
Figure 3- 9 Redesign Fin Braze .....	3-8
Figure 3- 10 Elimination of Blow-By Areas in 25 Pipe Coupon .....	3-9
Figure 4- 1 Part Scale” Test Unit for Ground Based Testing at Wyle in 2008.....	4-1
Figure 4- 2 Thermal Resistance - Model Comparison with Wyle Test Results.....	4-2
Figure 4- 3 Temperature and Power per HP .....	4-6
Figure 5- 1 Solid Model Extended Pipes & Fins as Fitted.....	5-1
Figure 5- 2 Cross Section Showing As-Designed Baffles Fitted in Shell.....	5-2
Figure 5- 3 Complexity of Baffles for Extended Heat Pipes .....	5-3
Figure 5- 4 Duct Designs .....	5-4
Figure 6- 1 Baffle Assemblies for Extended Length Heat Pipes, As-Built.....	6-1
Figure 6- 2 Cutting Diagram for Water Side Baffle Plates.....	6-3
Figure 6- 3 Water-Side View of HP-BAC Outside the Braze Furnace.....	6-4
Figure 6- 4 Water Side Heat Pipes with Residue after First Furnace Run.....	6-5
Figure 6- 5 Effective Cleaning.....	6-5
Figure 6- 6 HP-BAC Tube Sheet Being Immersed in Ultrasonic Cleaning Tank .....	6-6
Figure 6- 7 Heat Pipe Processing.....	6-6
Figure 6- 8 Thermocouples.....	6-7
Figure 7- 1 Thermocouple Placement and Numbering.....	7-1
Figure 7- 2 Thermocouples being pulled thru Conax seal on Water Side Shell .....	7-2
Figure 7- 3 HP-BAC Test Setup at Stork East-West Technology Corp. ....	7-2
Figure 7- 4 Schematic Diagram of Test Setup.....	7-3

Figure 7- 5 Data Set 1 at 550 °F (2:35 PM 5/13/10) .....7-6  
Figure 7- 6 Data Set 2 at 550 °F (2:50 PM 5/13/10) .....7-7  
Figure 7- 7 Data Set 3 at 620 °F (5:51 PM 5/13/10) .....7-8  
Figure 7- 8 Data Set at 630 °F (5:59 PM 5/13/10) .....7-9  
Figure 7- 9 Summary Sheet of Stork test Data and Thermocouples.....7-10  
Figure 7- 10 Reduction of Test Data and Comparison with Analytic Model Predictions .....7-12

## Table of Tables

Table 1- 1 DDG-51 Masker Cooler Technical Data .....	1-2
Table 4- 1 Thermal Resistances .....	4-2
Table 4- 2 Trade Study .....	4-7
Table 4- 3 As Built.....	4-8
Table 7- 1 Test Equipment and Calibration Data .....	7-4
Table 7- 2 Ratio of Measured to Calculated Heat Transport vs. Heat Pipe Resistance .....	7-13

### **Administrative Information**

The work described in this report was performed by the Energy Conversion Research and Development, Code 985, of the Research and Development Directorate at the Naval Surface Warfare Center, Carderock Division Ship Systems Engineering Station (NSWCCD-SSES), Philadelphia, PA. The work was funded by the Office of Secretary of Defense, Environmental Security Technology Certification Program – Weapons Platform WP-200302 (formally (PP-302) Task, between FY-03 and FY-10,



## **Acknowledgments**

The technical support for this technology effort has been numerous over the ten years in trying to bring this technology to finalization. The ESTCP program office was the main funding source for this program. The ESTCP office and staff, managed by Chuck Pellerin in the earlier years and Bruce Sartwell presently have been most supportive and patient in trying to get the technology to transition. Both Jeff Marquess presently and Bradley Smith formerly have been the leadership roles of the ESTCP & SERDP office that have also been supportive in the support of the technology development.

Two companies that were instrumental in helping to develop and finalize design efforts were Wiegman & Rose (W&R) and Advanced Cooling Technologies (ACT). Wiegman and Rose are the current builders of the Prairie, Masker coolers. Jacke Logan at W&R and his team helped finalized the shell enclosure design that was used for the prototype cooler, the redesign coupon and the final redesigned cooler. ACT was fabricator of the original prototype tube sheet. Dave Saraff at ACT worked extensively with Edison Welding Institute and Thermacore to finalize the the welding procedures used in the tube sheet fabrication.

In FY-04 during early fabrication it was identified that the Heat pipe tube-to-sheet-joining, welding distortion and brazing would be of some difficulties. MANTECH funded a small proposal under the Rapid Response Area of the Navy Joining Center NJC, Managed by Edison Welding Institute, Chris Conrady. These efforts were of great help in addressing both the weld and brazing issues with the project and are employed in the fabrication process.

In FY-05 it was identified that better fins would be required. Chuck Stark at ATI was instrumental at applying new developments in Semi Solid Metal castings for fin designs on the heat pipes. Ken Young at VForge was the integral part of the integrated product team of the American Metal Casting (AMC) consortium that provided the current fin design developed by Thermacore and NSWC which improved the performance immensely as part of the HPBAC redesign efforts.

Other contributors for the program were John Stone PMS-400F, Harry Skruch NAVSEA 05R, and James Buttram NSWCCD-Phila. Mike O'Neal and Jeffrey Sachs NAVSEA 05W helped fund the redesign effort with ESTCP to get the technology currently ready for final demonstration, Mark Browder NAVSEA 05 tracked the technology development in CWP with the intent that it would transition to Fleet upon successful demonstration. SERCO was the AIT contractor which performed the install in 2005 on the USS Ramage for the prototype dempnstration testing and were on track to complete the re-install for final demonstration upon completion of re-design pre-production build.

## Acronyms

ASW	Anti Submarine Warfare
AUX	Auxillary Room
BAC	Bleed Air Cooler
BAS	Bleed Air System
BTU	British Thermal Unit
BOSS	By Our Spares Smart Program
CuNi	Copper Nickel
DoD	Department of Defense
ECF	Empirical Correction Factor
EPA	Environmental Protection Agencies
ESTCP	Environmental Securities Technology Program
fpi	fins per inch
GTE	Gas Turbine Engines
HP	Heat Pipe
HP-BAC	Heat Pipe – Bleed Air Cooler
INSURVE	Inspection Survey Board established by Congress
LECP	Logistic Engineering Change Proposal Main Engine Room #1 (MER-1)
MER	Main Engine Room
MIP	Maintenance Index Page
MRC	Maintenance Requirement Card
MANTECH	Manufacturing Technology
MTBF	Mean Time Between Failures
NAVICP	Naval Inventory Control Points
NRL	Naval Research Laboratory
NSWC	Naval Surface Warfare Center
NSTM	NAVAL SHIPS' TECHNICAL MANUAL
OEM	Original Equipment Manufacturer
RCRA	Resource Conservation and Recovery Act
SIMA	Shore Intermediate Maintenance Activities
SSTG	Ship Service Turbine Generator
TEMPALT	Temporary Alteration
SURFLANT	Surface Fleet Atlantic
TEMPALT	Temporary Alteration

## Executive Summary

This executive summary describes a long term program to design and build a Heat Pipe - Bleed Air Cooler (HP-BAC) which will greatly reduce the saltwater scaling and calcareous deposits as compared to existing shell and tube heat exchangers. This involves power levels and environments far removed from those typically associated with heat pipe applications. The summary and highlights the concept and benefits, and the progress and setbacks encountered over its ten year life. The final report provides the details with various pictures showing the developments. The full scale pre-production HP-BAC was completed and successfully tested at a land base site. At the writing of this report no Navy proposals to transition or re-test have been funded to re-demonstrate this TRL-8 technology, in its real world performance in sea trials back aboard the DDG-68-USS RAMAGE or other DDG-51 Class ship under SCD 291.

**The Problem:** Bleed air is designed for 925°F but is typically extracted from the ship's generator or propulsion gas turbines at 550 to 700°F (288-371 °C) and is cooled using seawater, for use throughout the ship. The existing Bleed Air Cooler (BAC) is a simple two pass shell and tube heat exchanger, ambient temperature seawater circulating inside the tubes and the hot bleed air flowing over them. At the air inlet, the 550°F (288 °C) air heats the inside surface of the tubes far above the 150°F (65°C) temperature at which salt will scale out of the seawater and produce calcareous deposits. The deposits insulate the tubes, so the overall heat transfer is reduced, and the high temperature region of the tubes moves towards the air outlet, eventually fouling the entire heat exchanger. Once formed, the deposits require an acid bath to remove them. Removing the BAC's from the ship and cleaning them is extremely labor intensive and produce environmentally unfriendly waste streams. Reducing or eliminating the periodic cleanings would have both economic and environmental benefit

### FIRST PHASE HEAT PIPE HEAT EXCHANGER CONCEPT DEVELOPMENT:

#### **The Basic Design Concept:**

The basic concept was to separate the bulk flow of hot bleed air and the cool seawater, and make a thermal connection using heat pipes. The isothermal properties of heat pipes meant that the entire condenser (water) side of the heat pipe would be at the same temperature, and that temperature could then be controlled by adjusting the heat transfer surface area on the evaporator (air) side of the heat pipe. At the air inlet side, where the delta-T between the bleed air and the cooling water is at its maximum, using minimal number of fins reduces heat transfer to a level that will keep the surface temperature at which scaling becomes a problem. Note that the delta-T from the air to the heat pipe wall is more than 300 °F while the delta-T from the heat pipe to the water is less than 50 °F. The heat transfer is limited by the air side, so only the air side fin density is manipulated. By having fewer fins at the air inlet and a high fin density at the air outlet, the power per heat pipe can be kept relatively constant as the bleed air cools down, while also maintaining the heat pipe wall temperature below the scaling temperature throughout. The one drawback of this approach is that it deliberately introduces thermal resistance, reducing the volumetric thermal efficiency and necessitating a larger heat capacity.

#### **Other Design Considerations:**

The present bleed air coolers are rated for maximum transport of 425 kilowatts. The maximum heat transport per heat pipe is in excess of 3000 watts. The bleed air can reach 925 °F (496 °C at 75 psig). The seawater coolant is corrosive.

**Materials:**

The operating temperatures and the seawater coolant necessitated the use of copper nickel heat pipes to withstand the internal pressures and the corrosive coolant. Since that material had not been used before, four life test pipes were fabricated. Two were 90-10 CuNi, and two of 70-30. Three were placed on life test starting in may, 1999, and eleven years show no signs of gassing.

**Preliminary Thermal Design:**

The preliminary thermal design examined both thermal-mechanical stress and thermal performance. The design employed three different fin spacing's to produce three different heat transfer regimes to keep temperatures reasonably constant. The model results for this initial design consisted of 36 rows with 5 heat pipes per row. The initial design utilized fin sheets which ran the length and width of each module. This concentrated all the bending stress at the tube sheet interface where it exceeded the yield stress of the heat pipe tubes. Subsequent designs utilized individual fins for this reason.

**SECOND PHASE DESIGN BUILD AND TEST FULL SCALE PROTOTYPE:****Design:**

For the full size prototype, the design used three modules. The air side had 2 fins per inch (fpi) at the air inlet module, 3fpi on the middle module and 5 fpi on the outlet module. Each module had 13 rows of heat pipes with 5 heat pipes per row. The water side used 2fpi spacing for all modules. The structural analysis indicated that the tube sheet would have to be made thicker to conform to ASME Section VIII limits. The thicker plate was implemented, but at this time the heat pipes had already been cut to length and rather than throw away the relatively expensive material, it was used as is. While the reduction in length is only ¼ inch the reduction in the number of fins that could be fitted was almost 20%. The thermal design point was for bleed air at 925 °F (496 °F). As designed it was to transfer 416.9 kW. With a reduction of the number of fins to resolve some issues that arose during construction, it was calculated to transfer 336 kW in its as-built condition.

**Hardware:**

The HP-BAC was delivered for the Second Phase sea trials. The HP-BAC was installed aboard the DDG-61 USS Ramage in June 2005

**Second Phase Shipboard Test results:**

The HP-BAC was installed in parallel with an existing shell and tube heat exchanger where both could be in operation at the same time permitting a real time comparison. The test results were disappointing. Bleed air entered the BACs at 550°F (288°C), and the seawater entered at 70°F (21°C). For the shell and tube BACs, the air exited near 140°F (60°C). For the Heat Pipe BAC the air exited near 360°F (180°C). The heat pipe BAC was removing roughly 42% as much heat as the shell and tube BAC. Part of this discrepancy was due to bypass flow, where the air did not pass over the fins and heat pipes because of excess clearances to the shell. After baffle plates were installed to somewhat alleviate this bypass flow, the HP-BAC performance improved to almost 60% of the shell and tube.

It should be noted that the objective in going to the HP-BAC was to maintain the water side wall temperature below the 150°F (65°C) scaling temperature. Meeting this objective entailed the deliberate introduction of additional thermal resistance into the heat pipe thermal circuit, so its performance will be inherently less efficient than the shell and tube. In any event, the HP-BAC was significantly below its calculated performance level and the testing was terminated.

## **THIRD PHASE NEW PROTOTYPE PRE-PRODUCTION HP-BAC WITH LESSONS LEARNED:**

A number of issues with the second phase design had already been identified and would be directly addressed in the third phase. The heat pipes themselves, which had been subcontracted, seemed to be operating at about one-third of their expected conductance on average. The third phase would identify and resolve all issues and produce a test article to verify solutions. The following sections discuss the identified issues and the steps taken to remedy them.

### **Bypass Flow:**

The design models assume that the available water and air flow travel over the heat pipes and fins. There were excessive spaces between the heat pipes/fins and the shell that allowed fluid to bypass the heat transfer area. These spaces were left to accommodate the large tolerances on the shell and to provide some leeway during installation.

The obvious solution was to channel the flow to the heat pipes with a structure that was part of the tube sheet-heat pipe assembly rather than by adding baffles to the shell. Ducts were also added that could be moved out of harm's way when the shell was being attached to the tube sheet. This was relatively straightforward in the case of the part-scale test article.

### **Fin Form Attachment:**

Fins attached to heat pipes are generally stamped from aluminum or copper. For the BAC, the fins were made from thick Cu-Ni. Stamping was not an adequate process for this material and resulted in large gaps between the fin and the heat pipe wall. While tight connection between fin and pipe is desirable for thermal performance, the stamping results in spaces that are filled with relatively low conductance braze material, or in the worst case leave a void which is essentially nonconductive.

A new method of casting fins of Cu-Ni was employed. This was developed in the Copper Based Casting Technology Program between the Advanced Technology Institute (ATI) in Charleston SC and the US Army Research Laboratory with fins supplied by VForge Corporation of Lakewood CO.

With this new process, fins were produced to tight tolerances resulting in excellent braes. The fin-to-wall delta-T was reduced from >60 K on Second phase pipes to less than 10 K for the Third phase.

### **Heat Pipe Design and Process:**

When the second phase HP-BAC was returned to Thermacore, the heat pipes were individually tested with the results identified as follows: Only 10% were operating at design level, 55% partial degraded, 17% significantly degraded, and 18% non-operational. As designed and built in the second phase, these heat pipes were simple thermosyphons with no wick, and they were fabricated using the processes and procedures employed for mass produced copper-water heat pipes. This was clearly inadequate. Going forward the processes and procedures employed for high temperature liquid metal heat pipes were implemented, and a hydraulically actuated pinch-off tool, was used to provide a vapor tight pinch. The tool accommodates multiple dies to reduce stress in the pinched region. A test program showed that the heat pipes performed better with a wick to aid evaporation and to protect returning condensate from entrainment. A felt wick had attunement issues and a sintered metal powder wick was used for all the heat pipes.

### **Land-Based Test on "Part-Scale" HP-BAC to confirm Corrections and Calibrate Model:**

A Land-based test was conducted to confirm that the ducting, new fins and attachments, and the improved heat pipes all performed as expected. The part scale prototype which incorporated multiple length heat pipes to fully utilize the available volume. It is "part scale" in that it included only the first 25 of the 195 heat pipes that would populate a "full scale" unit. Testing was conducted at Wyle Laboratories in El

Segundo California. The test conditions included air flow of 2450 SCFM ( $70 \text{ m}^3/\text{min}$ ) at 75 psig (6.2 bar abs.) and  $700^\circ\text{F}$  ( $371^\circ\text{C}$ ). Water flow was 90 gpm ( $0.35 \text{ m}^3/\text{min}$ ), 35 psig (2.4 bar abs.) and  $85^\circ\text{F}$  ( $30^\circ\text{C}$ ). The analytic model calculated that the part-scale test unit would transport 54.9 kW. The actual transport per the Wyle data was 65.7 kW. The actual transport for this test was 65.7 kW. The actual transport phase test unit performed at only 80% of calculated performance using the same model, so the improvements were shown to be highly effective. Note that heat exchanger models are based on correlations rather than calculating from first principles. Since the HP-BAC is radically different from the heat exchangers upon which these correlations are based, a variation of 20% is not unreasonable.

#### **Full Scale Improved Prototype:**

To raise the transport capacity within the existing shell, multiple length pipes were used to more fully utilize the available volume within the circular shell. The multiple length pipes required a complex “wedding cake” baffle. This was a large contrast the multiple length heat pipes and the complex baffle in comparison to the uniform length mono height pipes rectangular baffle in the coupon. The calibrated model was used to optimize the total heat transport capacity of the HPBAC within the existing shell, while maintaining the maximum water-side heat pipe wall temperature below the seawater scaling threshold temperature during normal operation. Expanding the part-scale design to a fully populated full scale test configuration would have transferred 366.2 kW at the test condition of  $740^\circ\text{F}$  ( $393^\circ\text{C}$ ) inlet air. The maximum heat pipe wall temperature under these conditions would be  $186.6^\circ\text{F}$  ( $85.9^\circ\text{C}$ ). The full scale test article with multiple length pipes and optimized fins would transport 386.7 kW at test conditions with a maximum heat pipe wall temperature of  $170.1^\circ\text{F}$  ( $76.7^\circ\text{C}$ ). At its normal operating condition with inlet air at  $550^\circ\text{F}$  ( $288^\circ\text{C}$ ) the optimized design will maintain the maximum heat pipe wall temperature at  $148.6^\circ\text{F}$  ( $64.8^\circ\text{C}$ ), just below the salt scaling limit of  $150^\circ\text{F}$  ( $65^\circ\text{C}$ ). The full scale prototype is schedule for ground testing May 11, 2010 to confirm these calculated performance parameters, before being re-installed on the DDG-68 USS RAMAGE for subsequent sea trials.

#### **CONCLUSION:**

Land based testing of a part scale prototype 2009 confirmed the solutions to identified problems, and calibrated the analytical model. Shipboard testing of an expanded full scale prototype will hopefully demonstrate that the HP-BAC will significantly reduce the salt water scaling and its associated maintenance and environmental costs. To date all technology transition programs have rated very well however no funds were ever made available to complete final technology demonstration. Efforts are being explored to demonstrate the technology on hot geothermal plants or other foreign military ships

## Chapter 1 - Introduction

### 1-1 Background

#### 1-1.1 About the Masker and Prairie - Bleed Air Systems (BAS)

The Masker and Prairie Air Systems comprise most of the BAS that are used on U.S. Navy ships for Anti-Submarine Warfare (ASW) operations as well as turbine start and anti-icing. These systems use salt water to cool high temperature air off the gas turbines, for these ASW operations. These systems generate an air bubble screen to reduce the transmission of noise to the surrounding waters. The Masker Air System specifically reduces noise produced from the hull by discharging air through emitter belts located around the underwater girth of the ship while the Prairie Air system reduces propeller noise by discharging air from the leading edges of the propeller. Bleed air from Gas Turbine Engines (GTE) compressors, whether they are main propulsion model LM2500's or Ship Service Turbine Generators (SSTG) model 501K's, passes through a BAS reducing valve and then through a Masker & Prairie seawater cooler that is designed to reduce the bleed air temperature below 400°F. Prairie/ Masker system is used during both active and passive undersea warfare operations. Gas turbine ships routinely operate systems in port and at-sea, to avoid marine growth from plugging holes in blade tips and masker belts. An improper Prairie/Masker airflow rate is an ASW mission degrades.

The Masker and Prairie air coolers are shell and tube type coolers that are designed to cool bleed air with a temperature greater than 900°F using seawater passed around thin cooler tubes at a design temperature of 85°F. Table 1-1 provides a summary of the Masker cooler design parameters. The calcium carbonate scale build-up within the cooler at elevated temperatures over 150°F. Due to the scale's low thermal conductivity relative to the tubes this causes a reduction in cooler effectiveness. If the bleed air exiting the cooler reaches 435°F, the bleed Air-reducing valve closes and prevents further operation of the Masker and Prairie air systems for ASW operations.

The technology application of heat pipes in the masker cooler was selected to demonstrate the elimination of acid cleaning of these high temperature saltwater heat exchangers. The masker cooler was selected since it is 3 times the BTU capacity of prairie coolers in addition to being the most problematic of the high temperature salt water cooler heat exchangers. Main condensers another good application was not selected due to the difficulties in demonstrating new technologies in nuclear applications.

As planned in the ESTCP program, WP-200302, "Elimination of Acid Cleaning of High Temperature Salt Water Heat Exchangers" a full-scale demonstration prototype Heat Pipe - Bleed Air Cooler (HP-BAC) was constructed, delivered, and testing was done on the DDG-61, USS Ramage in MER-1 Masker cooler.

Note: DDG-51 class ships have a total of 5 shell & tube coolers:

- 2 in Main Engine Room No.1 (MER-1) (1 prairie and 1 masker)
- 2 in Main Engine Room No.2 (MER-2) (1 prairie and 1 masker)
- 1 in Auxiliary Room No.1 (AUX-1) (1 start air).

#### 1-1.2 Masker Cooler Problems

The BAS coolers on U.S. Navy surface combatants which support the Masker and Prairie air systems are unreliable, a maintenance burden, and costly to repair. This poor reliability significantly undermines the performance and reliability of other major components in the BAS. To highlight this problem, INSURV has identified the BAS as a poor performer in allowing ships to meet their ASW requirements. The basic problem is that scale builds up in the tubes of the tube bundle in the coolers, resulting in a severe loss of heat transfer capacity due to insufficient cooling of the bleed air. This phenomenon is due to the precipitation of calcareous deposits on the seawater side (in the tubes) of the shell and tube cooler.

In order to minimize the effects of the calcareous deposits in the coolers, a common maintenance practice is to perform an acid flushing either in-situ or after removal to a shore facility. The acid flushing creates a hazardous waste due to high concentrations of metal ions in the effluent and also because the waste generated has a pH lower than the minimum limit as specified under the Resource Conservation and Recovery Act (RCRA) [1]. Sailors and shore support personnel are often in direct contact with hazardous chemicals during and after the flushing procedure.

**Table 1- 1 DDG-51 Masker Cooler Technical Data**

PERFORMANCE DATA CHARACTERISTICS	MASKER AIR	
	SHELL SIDE	TUBE SIDE
FLUID CIRCULATED	AIR (1950 SCFM)	SEAWATER
FLOW RATE (LB/HR)	8,960	66,950
INLET TEMPERATURE (°F)	925	85
OUTLET TEMPERATURE (°F)	350	104.7
PRESSURE DROP (ALLOW/CALC) (PSI)	1.500/1.010	3.000/2.805
VELOCITY AT INLET FLANGE FACE (FT/SEC)	158.7	5.998
VELOCITY INTERNAL (FT/SEC)	19	5.998
NUMBER OF PASSES	1	2
DESIGN PRESSURE (PSIG)	100	50
TEST PRESSURE (PSIG)	150	100
DESIGN TEMPERATURE (°F)	925	300
LOG MEAN TEMPERATURE DIFFERENTIAL (LMTD) (°F)	487.318	
HEAT TRANSFER RATE SERVICE (BTU/HR/SQ FT./°F)	22.78	
HEAT TRANSFER RATE CLEAN (BTU/HR/SQ FT./°F)	29.9	
SURFACE AREA (SQ FT.)	117.9	
HEAT EXCHANGE (BTU/HR) (APPROX)	1,308,600	
WEIGHT DRY/FULL OF WATER (LBS)	485/550	
Air cooler -Masker	Type E Class 2	
Part Number	Part Number D2671	
Manufacturer	Wiegmann & Rose	
FSCM	78730	

## 1-2 Objectives of the Demonstration

### 1-2.1 Problem

High-temperature heat exchangers on ships generate scaling which results from the reduced solubility of calcareous salts at wall temperatures above 150 °F.

### 1-2.2 Solution

By using Heat Pipes (HP) to control the saltwater side wall temperature to below 150 °F, scaling and cleaning with hazardous materials is avoided and system reliability improved.



### **1-2.3 Objective**

The objective of this Environmental Security Technology Certification Program (ESTCP) project is to validate the elimination of acid cleaning of high temperature salt water heat exchangers, by applying heat pipe technologies to a masker cooler onboard a DDG-51 class ship. High temperature heat exchangers scale heavily as a result of operating at wall temperatures above 150°F. Scaling is a physical phenomenon resulting from the reduced solubility of calcareous salts at wall temperatures above 150°F. The problem is more acute in bleed air and main condenser heat exchangers due to hot-side operating temperatures as high as 925°F and 525°F respectively. Since the hot inlet gas can cause a large excursion in the tube-wall temperature on the seawater side of the heat exchanger, precipitation of dissolved solids in the seawater coolant occurs forming calcareous deposits on the tube walls. These deposits corrode and erode the walls causing cracks and holes. The corrosion and erosion resulting from scaling usually cause the heat exchanger failure. As a result, in-situ and shore-based depot chemical cleaning, both are costly and man-power intensive, and are required to help prevent corrosion and erosion, which lead to cooler failure. These processes use various cleaning chemicals, such as tri-sodium phosphate, sulfamic acid, and sodium carbonate. To support these cleaning procedures, the shore-based activities are required to carry excess hazardous materials, which can create up to 10,000 gallons of hazardous waste per application, with a disposal cost of \$2.58/gallon. Since the start of the program cost have tripled for hazardous waste

### **1-3 Regulatory Drivers**

1. Mandate by OPNAVINST 5090.1C, to reduce eliminate hazardous waste
2. Resource Conservation and Recovery Act (RCRA)

In selected applications, the implementation of Heat Pipe (HP) heat exchangers, as a replacement for traditional shell-and-tube type heat exchangers will obviate the need for cleaning chemicals, through elimination of scaling under high temperature conditions. By reducing or eliminating the use of hazardous materials aboard ship and in shore activities for heat exchanger cleaning, the need for the disposal of hazardous materials, as mandated by OPNAVINST 5090.1C [2], is also reduced or eliminated. This implementation will demonstrate advanced technologies and forward the technology development in the thrust areas of Pollution Prevention. The acid flushing creates a hazardous waste due to high concentrations of metal ions in the effluent and also because the waste generated has a pH lower than the minimum limit as specified under the Resource Conservation and Recovery Act (RCRA).

## Chapter 2 - Technology Description

### 2-1 Technology Development and Application

To eliminate scaling and the use of hazardous chemicals in bleed air system heat exchangers it is proposed that, a HP heat exchanger configuration be substituted for an existing shell-and-tube configuration. Within shell-and-tube bleed air heat exchangers (or other high temperature salt water heat exchangers) localized areas of the tube wall on the seawater side (i.e., tube side) experience very large escalations in temperature, see Figure 2-1. As mentioned previously, escalation in temperature allows the seawater wall to reach temperatures above 150°F and consequently, scaling occurs.

HP's provide a controlled intermediate fluid of water for the transfer of heat between a high temperature heat source (bleed air) and a low temperature heat sink (salt water), see Figure 2-2. Figures 2-3 and 3-1 show the proposed and as built prototype HP-BAC, respectively. The ability to closely control the temperature of this intermediate heat transfer fluid (water), contained in a hermetically sealed pipe, makes it possible to maintain the wall temperature at the cold end of the heat pipe below 150°F. Within the HP pipe water evaporates at the bottom of the pipe that is heated by the hot air and condenses at the top of the pipe that is cooled by the seawater. The heat transfer surface temperature on the condensation side is controlled by the ratio of the surface areas on the hot and cold sides of the pipe. The application of HP technology to this heat exchanger was identified as a potential solution to both the reliability problems and hazardous chemical reduction efforts. The reliability of this technology in marine applications has not been determined yet. However, it is anticipated that the HP heat exchanger will have a reliability far exceeding that of the existing shell-and-tube heat exchangers since HP technology have a mean time between failures (MTBF) of over 100,000 hours and have proven their reliability in various NRL and NASA space programs.

By reducing or eliminating the use of hazardous materials aboard ship for heat exchanger cleaning, the need for the disposal of hazardous materials, as mandated by OPNAVINST 5090.1C [2], is also reduced or eliminated. This implementation will also demonstrate advanced technologies and forward the technology development in the thrust areas of Pollution Prevention.

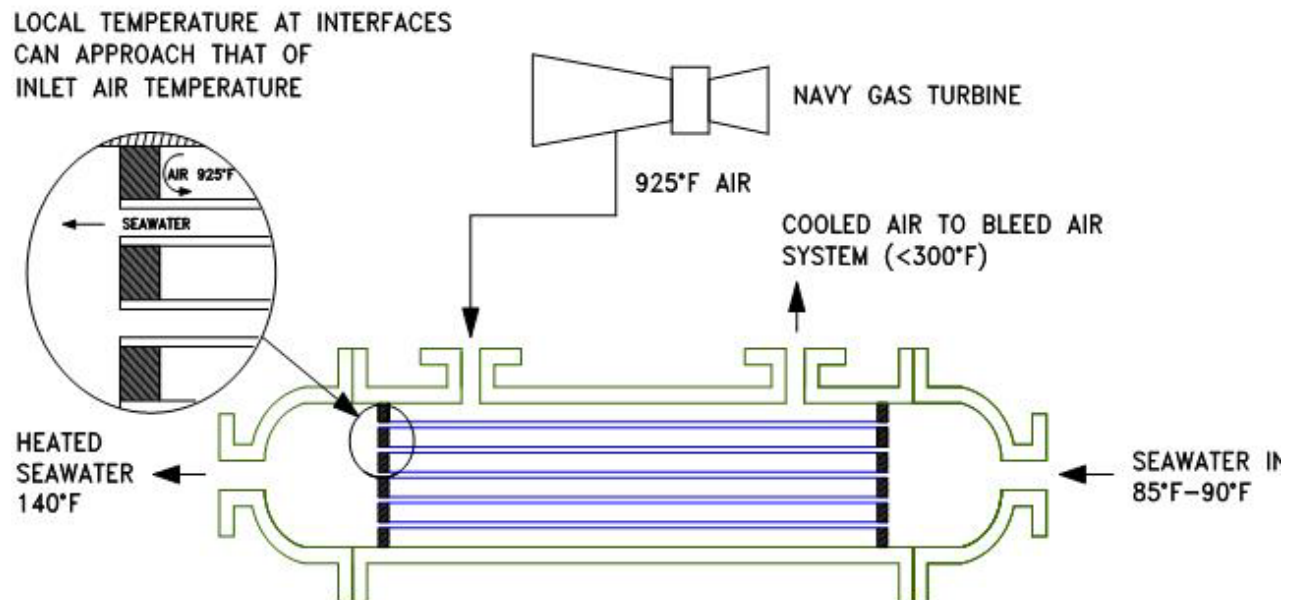
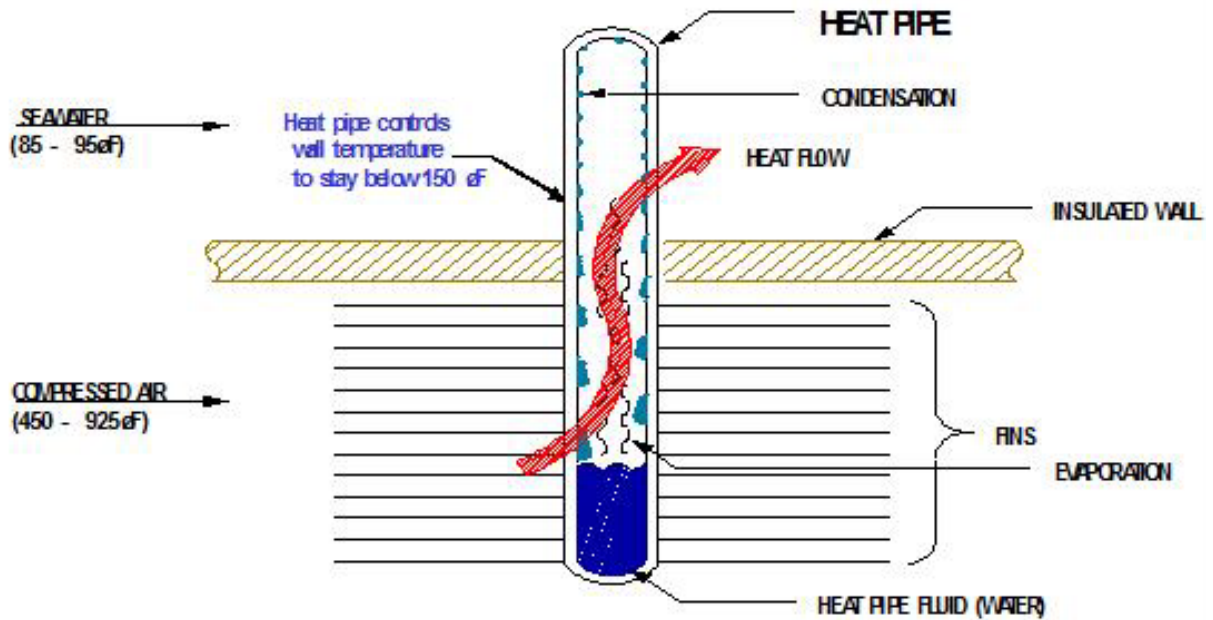


Figure 2- 1 Current Bleed Air System Shell & Tube Heat Exchanger Design

Shows current design and how localized wall temperature will approach inlet gas temperatures.

**NOTE**

**150 °F is the temperature where saltwater precipitates out calcareous deposits on the tube walls causing fouling and leakage on the tube walls**



**Figure 2- 2 Heat Pipe Technology**

Heat Causes Pressure gradient – forces vapor to cooler side (Condenser) – gives up latent heat of vaporization to seawater, condensate returns to hot side (Evaporator). Pipe geometry and fin densities control quantity of heat input to heat pipe there by controlling wall temperatures on the seawater side.

Error!

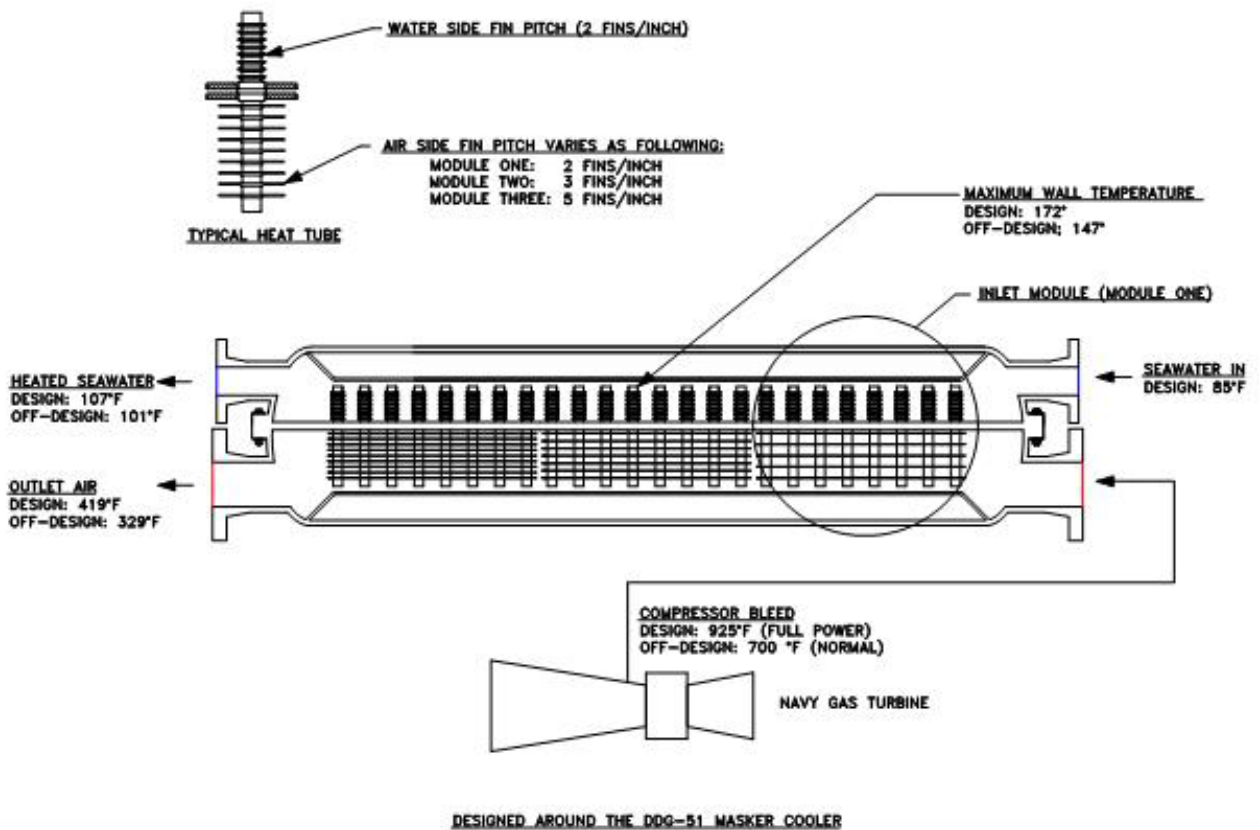


Figure 2-3 Proposed Full Scale "Heat Pipe" Heat Exchanger

## Chapter 3 - Technology Development as of November 2011

### 3-1 Program History

An abbreviated design study under a small R&D contract funded by NAVSEA-05R starting in 1999 showed the feasibility of using a HP-BAC to maintain the seawater side of the heat exchanger below the 150°F salt scaling temperature, thus greatly reducing fouling and the \$2.3 million per year maintenance costs and \$3 million in system support costs associated with the present shell-and-tube Bleed Air Cooler designs. The Phase I presented several workable designs and identified several technology development and modeling issues requiring further work prior to the fabrication of a prototype full-scale HP-BAC i.e. heat exchanger.

An advanced study in 2000 based on further modeling and technology development successfully validated the feasibility of the concept and provided the data needed to confidently proceed with the design and fabrication of a full-scale cooler with a shell enclosure.

In 2003 under contract N65540-03-C-0065 a full scale prototype HP-BAC was fabricated and delivered to NSWC. The design developments are documented in Appendix A. "Final –Design and Fabrication of a Prototype Full Scale Heat Pipe Bleed Air Cooler Heat Exchanger of Nov 17, 2005 by Thermacore.

The proposed demonstration HP-BAC Figure 3-1 was installed into the masker cooler location in MER-1 on board the USS Ramage DDG-61, see figure 3-2. The Temporary Alteration (TEMPALT), TEMPALT Number: DDG-51034, replaced the masker shell and tube cooler along with some system piping, foundation changes, and added an automated instrumentation package. Since the normal operation procedure is to operate both masker coolers in parallel the test plan was to do a comparison between the masker HP-BAC in MER-1 and the masker Shell & Tube – BAC in MER-2. A detailed demonstration test plan was developed for this shipboard testing, [3]. In short an effectiveness comparison would be made between the HP-BAC and the Shell & Tube -BAC. [4]

The installation of the prototype HP-BAC TEMPALT started on 2 June 2005 and was completed on 22 June 2005 onboard the DDG-61 USS Ramage. The automated data acquisition system recorded temperatures and flow data for the HP-BAC in MER-1 and a similar system recorded temperature only data on the Shell & Tube -BAC in MER-2.



**Figure 3- 1 Original Proposed heat pipe cooler before assembly and USS Ramage Install**

The performance of the full scale prototype HP-BAC as installed Figure 3-2 between June and Nov 2005 fell considerably short of predictions, reducing bleed air temperature by only 179°F, which was 125°F less than the expected reduction of 305°F. The bypass flow was known to be significantly worse than design conditions, so baffles were added and the unit reinstalled and tested again in July, 2005. The baffles improved heat transfer considerably; the unit reduced bleed air temperature by 220°F but this was still some 40°F less than the expected reduction of 260°F. The testing was terminated in Nov 2005 without obtaining any data on fouling performance. In addition to the bypass of much of the airflow around (rather than through) the heap pipe fins, see Figure 3-3 a number of other parameters fell short of the conditions used for the design calculations. Two other main contributors were fin attachment, see Figure 3-5 (pulled from Appendix A-D, EWI joining report) and the fact that only 10% of the heat pipes were operating as designed, with the remaining pipes operating at varying degrees of performance, see Figure 3-4. Note if a heat pipe is made correctly it would be operating at a 100% of its designed abilities. In Figure 3-4 the percentages represent the percentage at which the heat they were operating do to out gassing issues in the heat pipe. A full analysis can be seen in the “Post Analysis Report of the HP-BAC of March 30, 2007 by Thermacore and NSWC, Appendix – B.



# Elimination of Acid Cleaning in High Temperature Salt Water Heat Exchangers



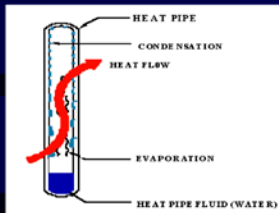
ESTCP-- WP- 0302

## 425kW Heat Pipe Bleed Air Cooler

## Installation of Cooler Technology on DDG-61

### OPERATION

- Heat from source evaporates liquid, thus removing heat
- Vapor rises to top of pipe and cools



### PROBLEM

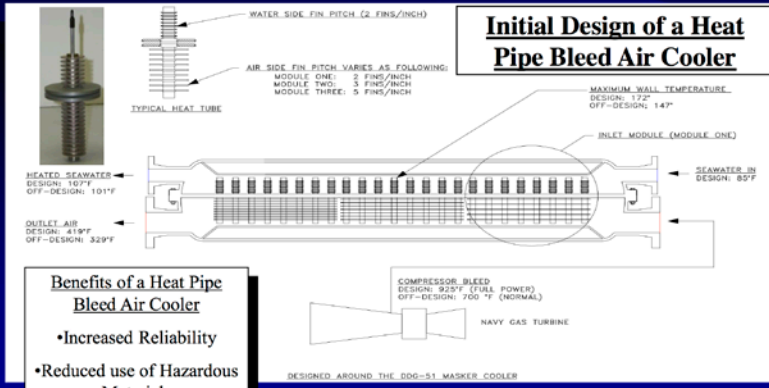
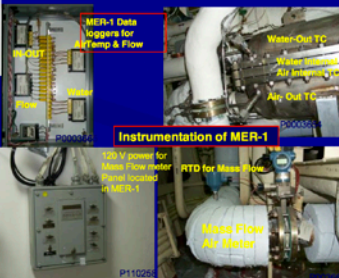
High-temperature heat exchangers on ships generate scaling which results from the reduced solubility of calcareous salts at wall temperatures above 150 F.

### SOLUTION

By using *heat pipes* to control the saltwater side wall temperature below 150 F, scaling and acid cleaning with hazardous materials is avoided and reliability is increased.

SHIPBOARD TESTING Start-July 05  
**Par Excellence**  
 Prototype  
 June 2005 to Nov 2005  
 Pre-Production  
 June 2008

TEMPALY DDG- 61034  
 Ship Change Document (SCD) - 291  
 RMMCO # MA-SURF-05-102779  
 2K for DFS tracking is EM01-Y738  
 DFS: Request R 231525Z June 05  
 Authorization R 241932Z June 05

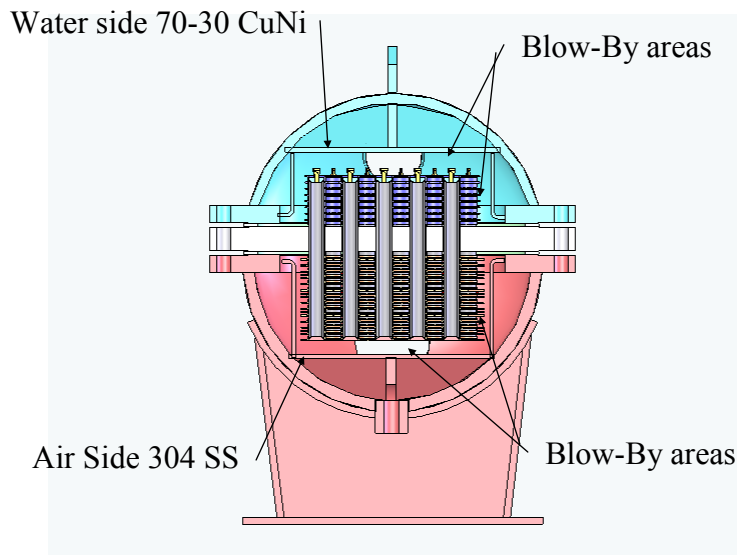


- #### Benefits of a Heat Pipe Bleed Air Cooler
- Increased Reliability
  - Reduced use of Hazardous Materials



TPOC Denis Colahan, NSWC-Phila, denis.colahan@navy.mil, 215-897-7231

Figure 3- 2 HP-BAC Installed on USS Ramage, DDG-61



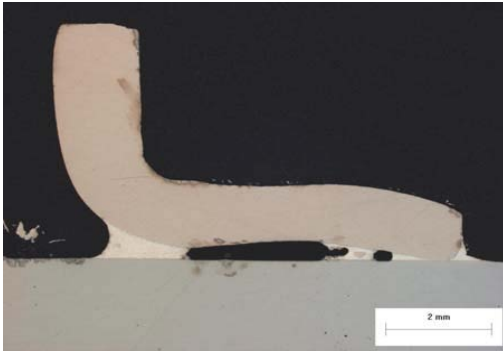
**Figure 3- 3 Original Prototype Full Scale HPBAC with Blow by Areas**

Operational HP below 35 C (95F)	19 Heat Pipes	10 %
Partially Operational HP 35 C to 65 C (95F to 149F)	105 Heat Pipes	54%
Significantly Degraded HP 65 C to 100 C (149 F to 212 F)	35 Heat Pipes	18 %
Non-Operational HP Above 100 C (212 F)	36 Heat Pipes	18 %

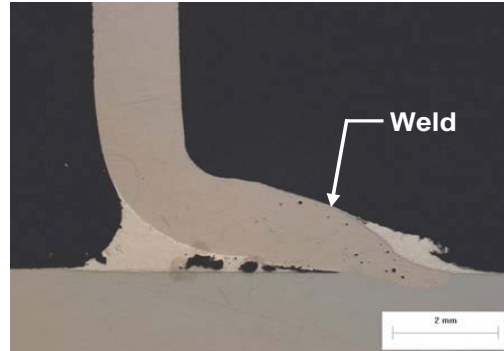


**Figure 3-4 Showing Post Analysis of Heat Pipe Capabilities in Original HPBAC**

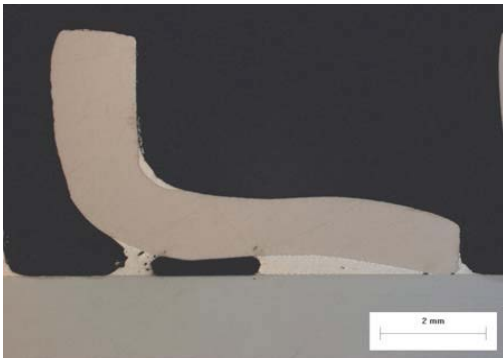




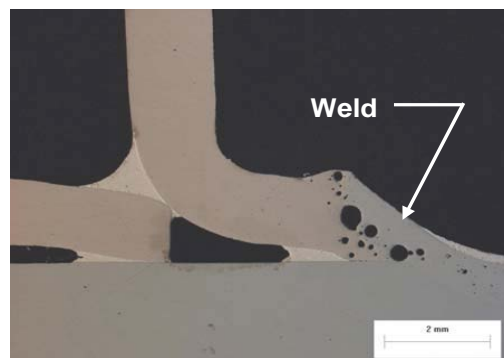
**Figure 25 - Assembly #1 Braze Joint Voids with Bowed Fin Leg**



**Figure 28 - Assembly #4 Braze Joint Voids with Porosity in Adjacent Weld**

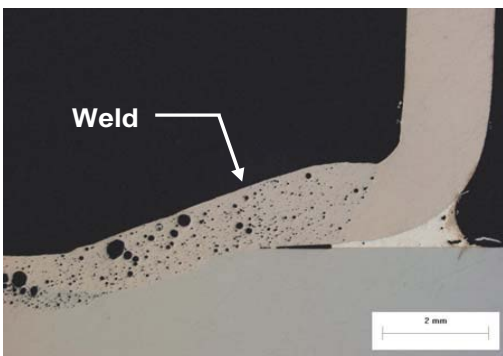


**Figure 26 - Assembly #2 Braze Joint Voids with Bowed Fin Leg**



**Figure 29 - Assembly #5 Braze Joint Voids with Porosity in Adjacent Weld**

The results indicate that the brazed fin-to-tube assemblies have moderate braze quality. Voids were found in all five of the examined assemblies.

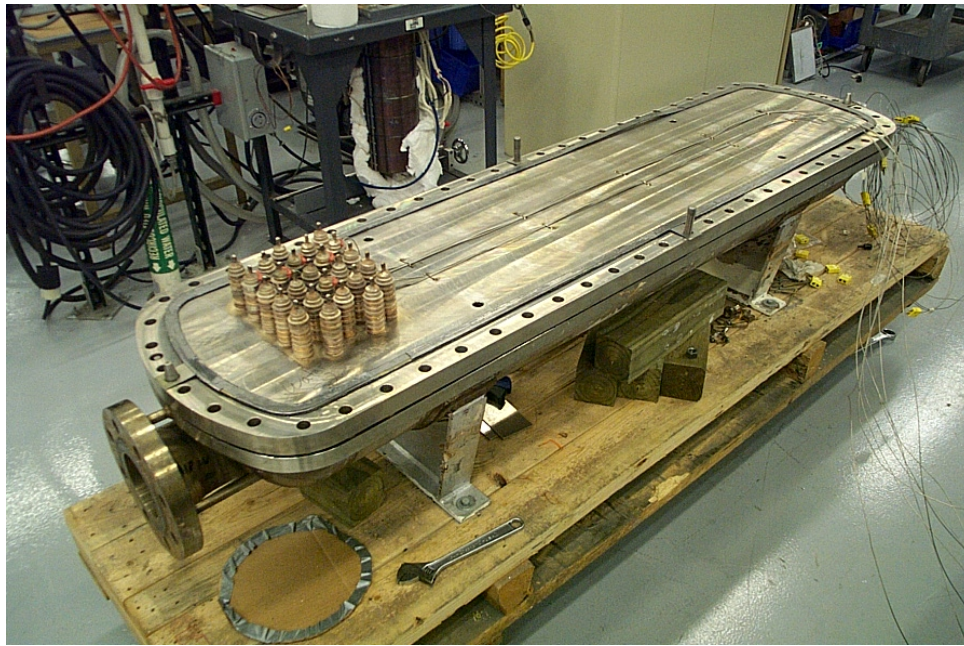


**Figure 27 - Assembly #3 Braze Joint Voids with Porosity in Adjacent Weld**

Figure 25 and Figure 26 are the micrographs of brazed joint assemblies #1 and #2. The likely cause of voids in these joints is the bowed shape of the fin legs. Bowed legs create a joint gap too large to retain the liquid alloy during brazing, thus causing voids or incomplete fill. The legs should be straight to provide a uniform joint gap prior to brazing. The voids may also be

**Figure 3-5 Various Figures From Page 20 of EWI Report Showing The Silver Brazing of Fins to The Heat Pipes (In Appendix A of this report A full report by EWI on joining is located in Appendix A-D)**

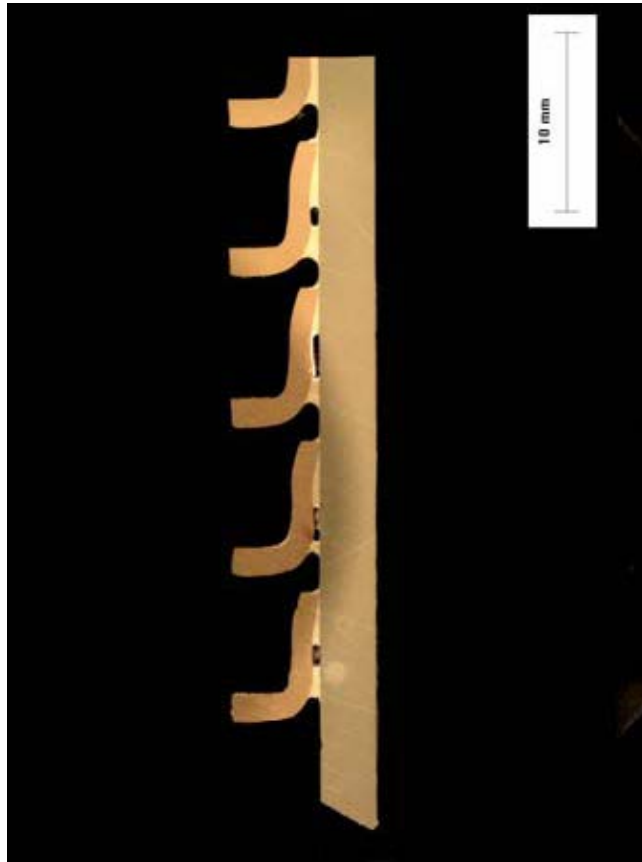
The second contract with Option N65540-06-C-0022, Redesign of Pre-Production full scale HP-BAC was instituted to analyze the work under the previous contract N65540-03-C-0065, determine the causes of the performance shortfall, implement plans, and designs to correct those problems, build a test unit, and confirm that the designs corrected the problems so that the HP-BAC was worth going forward. These efforts are fully reported in the “Final report – Redesign of FS-HPBAC of August 29, 2008 by Thermacore, Appendix - C. Changes were incorporated into a partial scale test unit consisting of 25 heat pipes. With the interest of cost in mind, a new tube section was purchase, milled and drilled for only 25 pipes, then installed into the original full scale HP-BAC shell sections. The 25 heat pipes remained a single length (mono-height) pipe that began ground testing at Wyle Laboratories in April 2008. With some facility problems, testing continued through June 2008. Test results showed that the test unit achieved all its design objectives and exceeded its expected performance by 15%. The reason for a 25 heat pipe coupon test was to validate that the heat pipe redesign could meet design goals. There was a high degree of confidence it would meet the performance requirements , however both NSWC and the ESTCP offices needed to document before moving forward with the full scale redesign. The base contract of N65540-06-C-0022 validated this. The Option 1 on the contract N65540-06-C-0022 would move the fabrication to the full scale redesign which had a lot of addition challenges which were overcome to complete the final design and test successfully.



**Figure 3-6 Fabrication of 25 Pipe Coupon At Thermacore**



**Figure 3-7 Testing Small coupon at Wyle Labs**

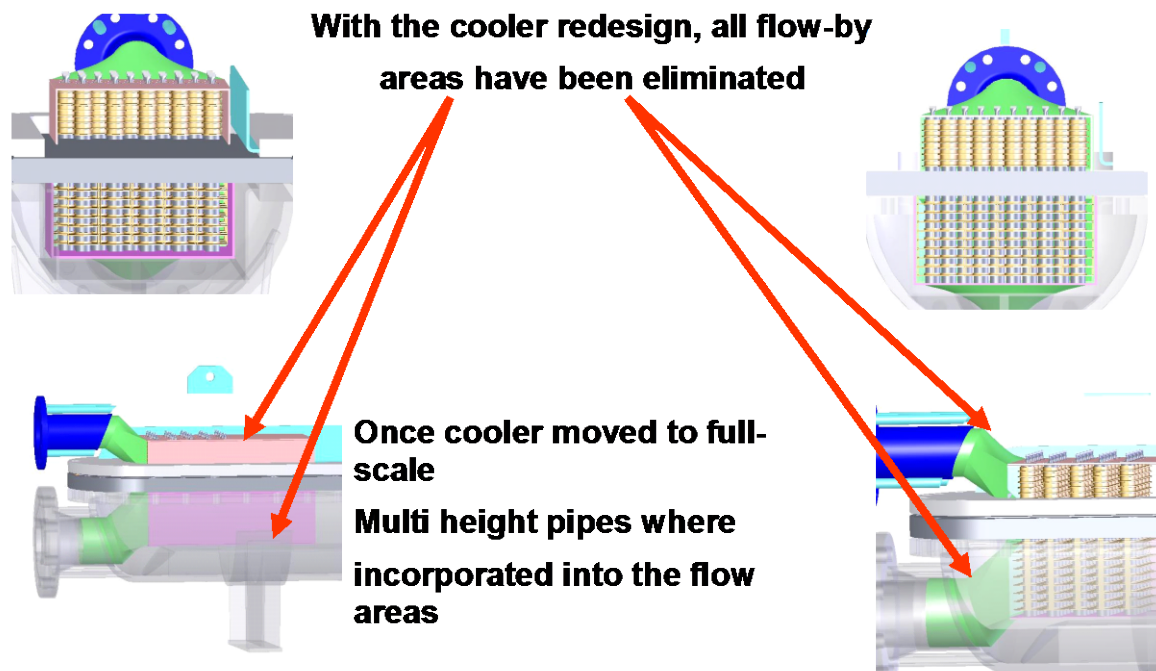


**Figure 3- 8 Original Fin Braze**



**Figure 3- 9 Redesign Fin Braze**

These two figures also show the significant change from making the Heat Pipes with class 700 pipes vice Class 3300, CuNi 70/30 pipes. Note class 700 and 3300 are the psi ratings the tube



**Figure 3- 10 Elimination of Blow-By Areas in 25 Pipe Coupon**

With the base contract successful results, NSWC exercised Option 1 of the base contract N65540-06-C-0022 in February 2009, to proceed with a Pre Production Full Scale HP-BAC for shipboard testing. The contract option was amended to fully utilize the available envelope by using multiple length heat pipes, and to perform another ground-based test before installing the unit for shipboard tests. This report describes the work accomplished under the entire project with most of the early work covered in the various appendices.

### **3-2 Summary of Previously Reported Work under base contract N65540-06-C-0022**

The following list the major accomplishments of the base contract with the reference in parentheses providing a reference to the section of the Final Report- Redesign of Full Scale HP-BAC of August 29, 2008 by Thermacore, Appendix - C that describes them in detail.

#### **3-2.1 Test and Diagnosis**

The old HP-BAC was extensively tested. Only 10% of the heat pipes were operating at fully rated performance. The problems with fins and bypass flow were confirmed. This work was reported in Section 3 of Appendix - C.

#### **3-2.2 Redesign of HP-BAC**

The heat pipe processing was changed so the copper-nickel heat pipes were processed the same as liquid metal heat pipes rather than the simpler procedures followed for commercial copper water heat pipes. Instead of simple thermosyphons, a number of improvements were tried and sintered copper wicks were added to the design. (The heat pipe improvements were reported in Section 4.1 of Appendix - C)

The formed fins could not be efficiently brazed to the tube walls, resulting in large thermal resistance. Cast fins were used from Vforge with support from Advanced Technology Institute and US Army Research Lab. Delta-T was reduced from 62°C to less than 10°C with the new fins and brazing. (The fin improvements was reported in Section 4.2 of Appendix C and Appendix-D Improved Fin Attachment and Fin Count of Sept-28, 2007)

### **3-2.3 Fabricate and Test Heat Pipes**

More than forty heat pipes of various configurations were fabricated and tested. Potential problems with gassing and weld cracking were identified, solved, and design changes were implemented to preclude them in the future. (This work was reported in Section 5 of Appendix-C). Other significant design change was the class of pipe used to make the pipes went from a class 3300 to a class 700.

### **3-2.4 Design and Fabricate HP-BAC Engineering Test Unit. (25 Pipe Coupon)**

A system of ducts and baffles were designed built and installed to resolve the bypass flow issues. Heat pipe processing was upgraded to preclude the degradation observed on the shipboard test unit. A full scale, but not fully loaded (25 HP only), Engineering Test Unit BAC was fabricated and delivered for full scale testing at Wyle Labs. (This work was reported in Section 6 of Appendix - C)

### **3-2.5 Testing**

Testing was conducted at rated temperatures and flow in the Wyle facility in El Segundo CA from April 15 through June 12, 2008. The Engineering Test Unit HP-BAC carried more power at a lower delta-T than predicted by the design models. (This work was reported in Section 3 of Appendix -C)

### **3-2.6 Results**

Based on the official test data from Wyle Laboratories, the HP-BAC transported 15% more power than predicted by the design model. The testing conclusively confirmed that all the corrections/improvements that were made following the unsatisfactory tests aboard the USS Rampage in 2005 resulted in the HP-BAC not only meeting, but far surpassing the original design objectives.

## **3-3 Major Tasks Under the Option 1/Amendment Work of N65540-06-C-0022**

Contractually, the work consisted of the following tasks:

- a. 001 Refine Mathematical Model and verified calculations for full scale HP-BAC
- b. 002 Refine Structural and Thermal Analysis for full scale HP-BAC
- c. 003 Final Redesigned Preproduction full scale HP-BAC
- d. 004 Deliver one full scale HP-BAC for shipboard evaluation along with testing.
- e. 005 Final Report

These contractual tasks were performed in the following functional tasks.

### **3-3.1 Re-correlate Analytic Model and perform Trade Study**

This task adjusted the model so its output matched the Wyle test data. The adjusted model was then used to maximize heat transport while minimizing water side temperature.

### **3-3.2 Extend Pipes to Fully Utilize Existing Shells**

This task fit the maximum area of fins, the maximum length of heat pipes within the existing shells.

### **3-3.3 Design New Ducts and Baffles**

With the new heat pipe geometry, this task designed, fabricated and fit new ducts and baffles to best direct air and water flows thru the extended heat pipes without allowing any bypass flow.

### **3-3.4 Fabricate Full Scale HP-BAC**

The full scale, fully loaded, instrumented Heat Pipe Bleed Air Cooler was fabricated and instrumented.

### **3-3.5 Land Based Test of Full Scale HP-BAC**

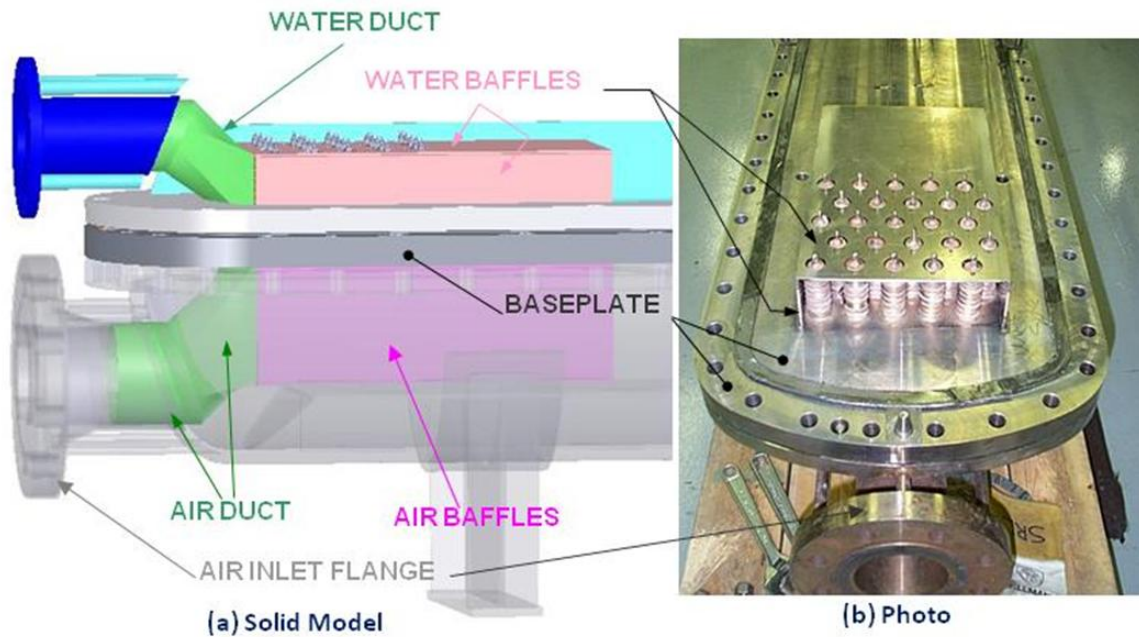
The HP-BAC was then tested at Stork East-West Technology Corp under operating temperature and flow conditions to verify its performance before considering shipboard testing.

## Chapter 4 - Re-correlate Analytic Model and Perform Trade Study

### 4-1 Re-correlate Analytic Model

#### 4-1.1 The Wyle Labs Test and Data

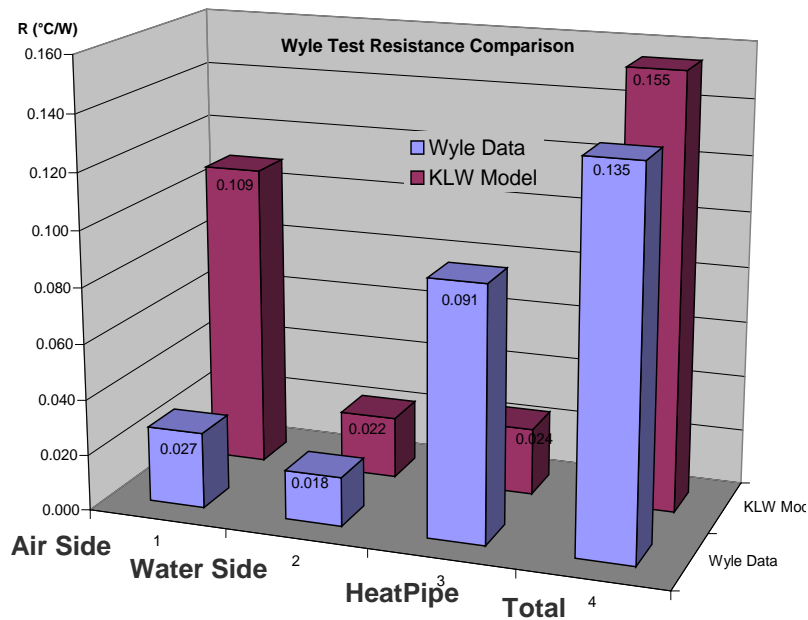
The “test coupon” or “subscale test unit” was subscale only in that it consisted of the first 5 rows out of the 39 rows of heat pipes that would be installed on a fully loaded unit. It had the short heat pipes used in the original shipboard tests, but included ducts and baffles to direct all air and water flow over the fins and heat pipes and eliminate the bypass flow. Figure 4-1 shows the test unit. The purpose of the test was to show that the changes in fins, processing, ducts and baffles, etc, worked, and to use the test data to verify and re-calibrate the analytic model.



**Figure 4- 1 Part Scale” Test Unit for Ground Based Testing at Wyle in 2008**

The test was set up in April, 2008 and first data was obtained on April 19. A number of problems and anomalies were evident, and the definitive test was run on June 12, 2008. Details of the testing were reported in the Test Report of August 12, 2008 by Thermacore and Wyle Labs Appendix - D along with analysis of the results. The testing is also reported and analyzed in the “Final Report, Redesign of Full Scale Heat Pipe Bleed Air Cooler Heat Exchanger” of August 29, 2008, Appendix - C. The overall test result indicated that the HPBAC was transporting 15% more heat than the analytic model (“KLW” in figure) was predicting. As shown in Figure 4-2, the allocation of thermal resistances varied considerably more than the overall variation between the model and the test results. The anomalously low air-side resistance was based on the test thermocouple readings which were concluded to be reading closer to the air temperature than to the heat pipe wall temperature they were supposed to be measuring. This error would also make the heat pipe resistance anomalously high to balance the overall measurements. The overall heat transport was measured using thermocouples not subject to this error and still maintained the 15% variation. The overall test result indicated that the HP-BAC was transporting 15% more heat than the analytic model (“KLW” in figure) was predicting.





**Figure 4- 2 Thermal Resistance - Model Comparison with Wyle Test Results**

This test value was certified by Wyle and subsequently used to re-correlate the analytic model, but it should be noted that in Section 7.5.2 of the Final Report-Redesign of Full Scale HPBAC, Aug 29, 2008 Appendix-C, the Thermacore project engineer expressed the following reservations:

**Table 4- 1 Thermal Resistances**

Category Parameter	WYLE AVERAGE	KLW MODEL
$R_{\text{airside}} (^{\circ}\text{C}/\text{W})$	0.027	0.109
$R_{\text{H2Oside}} (^{\circ}\text{C}/\text{W})$	0.018	0.022
$R_{\text{HP}} (^{\circ}\text{C}/\text{W})$	0.091	0.024
$R_{\text{total}} (^{\circ}\text{C}/\text{W})$	0.135	0.155

*These comments come from Thermacore's redesign final report, Appendix C, section 7.5:*

*“ Project Engineer's Conclusions/Interpretations/Conjecture*

*The Thermacore project engineer had two conclusions which are based on a feel for the data and the hardware:*

- 1. The Wyle data for water flow and/or water power is high. The correct flow/power is somewhat lower. This conclusion (conjecture) is based on the following indications:
  - a) Most of the tests run at Wyle had the water removing more energy than the air was supplying. These corrections involved moving the water flow meter so it was not picking up cavitations on the downstream of the throttling valve, and moving the water inlet so it was not sucking air at the inlet. Both errors resulted in over-stating the water flow rate.*
  - b) The water power data is layered (see Figure 28) which indicates some smoothing function is being applied to the data collection which has not been identified.*
  - c) The heat that is being lost to ambient air from the un-insulated Bleed Air Cooler, while not impossibly low, is much less than would be expected for the test conditions. Reducing the water flow/power value would raise the overall resistance and reduce the variance with the model.**
- 2. The heat pipe resistance value used in the models is still too low. The present value is the absolute minimum of what it could be.”*

#### **4-1.2 The Analytic Model**

The thermal circuit consists of three resistance paths in series. There are the air side fins and heat pipe wall, the heat pipe, and the water side fins and heat pipe wall.

The air side heat transfer coefficient is calculated using the lower value of the Zhukauskas (1972) [5] correlation for plain tube banks and the Briggs and Young (1963)[6] correlation for individual circular fins.[6] For the test conditions, these correlations differ by less than 0.7%.

The water side was based on Webb “Principles of Heat Transfer”, the Zhukauskas correlation [7] for finned tube banks, and geometric fine-tuning discussions between Dr. Wert of Thermacore and Dr. Donald Knauss at NSWC.

The thermal resistance of the heat pipe is simply treated as an input parameter within the HP-BAC model. The HP-BAC design was based on heat pipe thermal resistance of 0.07 K/W. The instrumented heat pipes in the shipboard tests averaged 0.205 K/W, a factor of three higher than design.

Note that all heat exchanger calculations are based on correlations rather than closed-form solutions from first principles. Correlations vary depending upon exact configuration that was tested as compared to the configuration and conditions used to generate them.

#### **4-1.3 Preliminary Analysis**

This analysis was performed in preparing the final report cited above.

##### **4-1.3.1 Heat Loss Analysis**

The Wyle data was used directly. The heat loss model calculated that 12.5 kW was being transferred to the water thru the tube sheet (plate). Since the Wyle data indicated that the water had absorbed 78.2 kW, this meant that the heat pipes were transferring 65.7 kW.

The heat loss program calculated that 7.86 kW was being lost through the un-insulated shell of the BAC. This should account for the difference between the heat loss by the air (80.5 kW) and the heat gained by

the water (78.2 kW). The measured difference of 2.3 kW is less than 1/3 of the calculated 7.86 kW. For the 6/10/08 test the measured difference was 81% of calculated.

#### **4-1.3.2 HP-BAC Model Analysis**

The HP-BAC model could not balance the 65.7 kW that the heat pipes were apparently transporting based on the Wyle data. If a heat pipe resistance of 0.001 °C/watt was assumed in the model, the calculated heat pipe power was 62 kW compared to the 65.7 kW test value. At this resistance the model predicts heat pipe wall temperatures of 97.0 and 93.1°C which are much higher than the 84.5 and 88.3°C measured during the test.

When the model was run at a reasonable resistance of 0.020 °C/watt, it predicted heat pipe wall temperatures of 89.8 and 86.9°C which compare well with the measured values. At this resistance the model calculated heat pipe power of 54.9 kW which is far short of the 65.7 kW indicated by the Wyle data.

#### **4-1.4 The Analytic Model Recorrelation**

##### **4-1.4.1 Heat Pipe Resistance**

The analytic model does not directly model the heat pipes; it simply incorporates a resistance value. Directly measuring the resistance of the heat pipe in the Thermacore facility proved extremely difficult. The heat pipe resistance includes the fins and their attachment. With the fins attached, the geometry made heat input and output extremely challenging. The behavior of hot air coming thru fins is significantly different than the behavior of a directly attached heater block over a small area.

###### **4-1.4.1.1 Heat Pipe “D” Test**

A test rig was constructed that used hot air from a heat gun as the heat input, and pumped water as the heat removal mechanism. Since the losses on the air side were not controllable, the heat input was assumed to match the heat being removed by the water which was measured by the temperature gain of the water and its carefully measured flow rate. This testing is described in section 7.3.4 of the final report Appendix-C. The Heat Pipe D testing yielded a heat pipe resistance value of 0.0175 °C/watt. To put this into perspective, the HP-BAC tested aboard the Ramage was designed assuming a heat pipe resistance of 0.07 °C/watt, and the heat pipes in the shipboard test averaged only 0.205 °C/watt. The minimum resistance that the heat pipe could have, calculated from first principles, was 0.024 °C/watt. It was hoped that the Wyle land based tests would provide a definitive heat pipe resistance for use in the model.

###### **4-1.4.1.2 Land Based Test at Wyle Labs**

As shown in Table 4-1 above, the direct data from the Wyle test resulted in anomalously low air resistance and anomalously high heat pipe resistance values. This anomaly was attributed to the thermocouples used for these calculations measuring the air temperature directly instead of the heat pipe wall temperature in the air stream. Table 4- 3 below shows the temperature measured by these thermocouples in the test, and the temperatures calculated by the model for the heat pipe wall at the thermocouple location and the temperatures actually measured during the test. It also shows the inlet and outlet air temperatures. Clearly the t/c is dominated by the air temperature rather than the wall temperature which is not surprising since they are immersed in a turbulent flow of extremely hot air. The large error in air side temperature measurement precluded an accurate calibration of the heat pipe resistance under actual operating conditions.

##### **4-1.4.2 Overall Heat Transport**

The Wyle test measured flow rate and inlet temperatures for both the air and water sides. The total heat transferred to the water per these measurements was 78.2 kW, and the heat removed from the air was 80.5 kW. The difference between these values is the heat that was lost thru the un-insulated shell of the BAC.

The water side transport was 15% greater than predicted by the model. The model was therefore adjusted to match the data.

#### **4-1.4.3 Recorrelation of the Analytic Model with Test Data**

In a fully populated bleed air cooler with complete ducting, the heat transferred thru the tube sheet can be neglected, but in this part-scale test article it must be considered. A heat loss program was written to calculate the heat transferred to the water directly thru the tube sheet. It calculated that to be 12.5 kW, which when subtracted from the 78.2 kW that the water was removing based on test measurements, meant that the heat pipes were transferring 65.7 kW. The model was predicting 57.3 kW, under-predicting by 15%. A number of changes were considered and made to best match the model and the data.

##### **4-1.4.3.1 Heat Pipe Resistance**

The test did not provide good data to calculate the resistance directly. As an input parameter to the model, rather than a direct calculation within the model, the heat pipe resistance would be a natural parameter to change, especially since the Heat Pipe D testing would indicate that the resistance was much lower than had been used in the model. Manipulating the value for heat pipe resistance in the model showed that even by reducing it to zero would not increase the heat transport by 15% to match the Wyle data.

##### **4-1.4.3.2 Heat Transfer Coefficient Correlations**

As described in section 4.1.2 above, the heat transfer coefficients for both air and water side were based on published correlations for tube bank heat exchangers. These correlations are not derived from first principles, but depend on empirical constants determined by experiments. Since the geometry and flow conditions within the HPBAC are quite different from those in the experiments, considerable variation in the empirical constants would be expected for this application. Although efforts were made to account for these differences, a variation of 15% in calculated heat transport would not be totally unexpected.

##### **4-1.4.3.3 Water side Temperature Measurements**

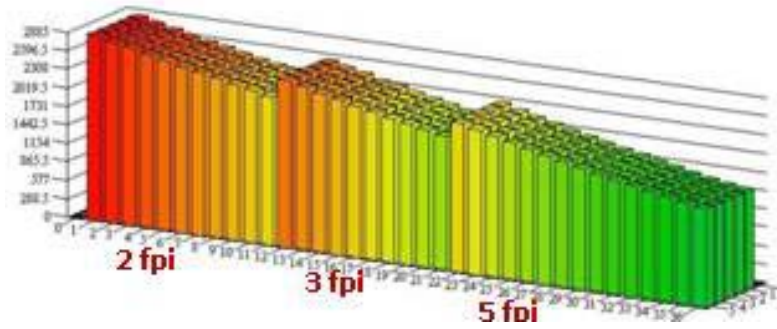
The waterside temperatures as measured at Wyle were much higher than calculated, but were not subject to the error source attributed to the air side measurements. (If the t/c were in the water stream rather than in good contact with the heat pipe wall, the measured temperatures would be lower than calculated, rather than higher.) Taking these measurements as a boundary condition will constrain adjustments made to the model.

##### **4-1.4.3.4 Re-Correlation of Analytic Model:**

Since there was no value for heat pipe resistance that would match the data, and since the best independent measurement showed an anomalously low value, the heat pipe resistance was set to its minimum theoretical resistance value of 0.024 °C/watt.

Using the new value for heat pipe resistance, empirical correction factors were added to both the air and the water heat transfer coefficient equations in the model. These were manipulated until both the thru-the-heat-pipes heat transport, and the water side heat pipe temperature predictions, matched the values measured at Wyle. The best match was achieved for a value of 1.41 for both the air and water Empirical Correction Factors. ( $ECF_{water} = ECF_{air} = 1.41$ )

Using these ECFs, the calculated heat transport was 65.8 vs. 65.7 kW measured, and the heat pipe wall temperatures were 85.89°C and 82.91°C versus measured temperatures of 84.5°C and 88.3°C.



**Figure 4- 3 Temperature and Power per HP**

Two boundary conditions are crucial to this trade study on the air side.

The first is that adding more fins at the inlet would raise the wall temperature above 150°F. This effectively constrains the inlet to no more than 2 fins per inch.

The second constraint is that the manufacturing process and geometry for the 90/10 copper/nickel fins will not allow the fins to be spaced closer than 5 fins per inch. This constrains the maximum number of fins per heat pipe.

The results of the trade study are summarized in Table 4-2.

**Table 4- 2 Trade Study**

		<b>Q<sub>total</sub></b> <b>(kW)</b>	<b>HP T<sub>max</sub></b> <b>(°C)</b>	<b>HP T<sub>max</sub></b> <b>(°F)</b>	<b>dQ/dT</b>	<b>Air Out</b> <b>(oC)</b>	<b>Air Out</b> <b>(oF)</b>
1	Original Normalized to Wyle	366.2	85.9	186.6		137.9	280.2
2	Original 4fpi on water	369.2	81.6	178.9		135.8	276.5
3	Original 5 fpi on water	371.8	77.8	172		134	273.2
4	REF Fully Loaded	388.7	76.7	170.1		121.8	251.2
5	4 Modules (1.5, 2, 3, 5 fpi)	373.7	73	163.3	4.02	131.4	268.5
6	4 Modules (1, 2, 3, 5 fpi)	370.4	73.5	164.3	5.76	134.8	274.6
7	5 Modules (1, 1.5, 2, 3, 5 fpi)	362.3	72.2	161.9	5.8	139.3	282.8
8	REF if All air Fins were 5fpi	409.7	86.3	187.3		105.3	221.5
9	REF at 550°F	270.1	64.8	148.7		96.9	206.4

The first (1) line makes the model match the Wyle data for five rows of heat pipes and then extends the model to populate all 39 rows of heat pipes. The second (2) line changes from 3 fins per inch to 4 fpi. The third (3) line of the table shows the effect of going to 5 fpi. During the original design, the positive but very small change in power (0.8%) associated with a 33% increase in the number of fins was considered to be beyond the point of diminishing returns. However, the addition of fins to the water side results in a 4°C decrease in the heat pipe wall temperature going from 3 to 4 fpi and another 4°C decrease going from 4 to 5 fpi, and this improvement was deemed to be worth the cost. All subsequent lines are based on 5 fpi on the water side.

The fourth (4) line shows what the model achieves with the longest pipes that would fit. Subsequent lines include the longest pipes.

The fifth, sixth, seventh (5), (6), (7) lines show the results for increasing from the three different fin spacings to four or five different fin spacings. Adding modules reduces the heat pipe wall temperature by 3.2 - 4.5°C, but reduces heat transport by 15-26 kW. Making these changes would require two new types of fins with two new set of dies to make them. This would affect schedule as well as cost. The trade of reduced power for improved wall temperature was not considered worthwhile, especially in view of the cost and schedule impact.

The eight (8) line shows the heat transport and wall temperatures that would be achieved if all the air side fins were at 5 fpi. This was calculated to show the maximum power that could be extracted from the BAC shell with the present fin technology. The resulting high heat pipe wall temperature of 187.3 °F defeat the whole purpose of the program

The ninth (9) and final line in the table shows the power and wall temperatures that the reference design would provide when operated at the normal air inlet condition of 550°F. It is seen that this design provides a heat pipe wall temperature below the 150°F scaling temperature.

As fabrication proceeded it became necessary to slightly reduce the number of fins in order to clear the baffles and fit inside the existing shells. The “As Built” calculations are shown in Table 4-3. The 740°F case corresponds to the conditions in Table 4-3. Again note that the difference between "REF" in trade study and "AS BUILT" is the deletion of a few fins to fit baffles.

**Table 4- 3 As Built**

	<b>Qtot (kW)</b>	<b>HP Tmax (°C)</b>	<b>HP Tmax (°F)</b>	<b>dQ/dT</b>	<b>Air Out (°C)</b>	<b>Air Out (°F)</b>
AS BUILT <b>550°F</b>	268.7	64.8	148.6		97.8	208.0
AS BUILT <b>700°F</b>	362.3	74.3	165.7		117.7	243.9
AS BUILT <b>740°F</b>	386.7	76.7	170.1		123.0	253.4

## Chapter 5 - Extend Heat Pipes to Fully Utilize Existing Shells

### 5-1 Extended Heat Pipes and Fins

The left side of Figure 5-1 shows the extended heat pipes as they fit in the solid model of the shell. This also shows the original length of the heat pipes. Note that the air side shell is considerably higher than the water side shell. Percentage-wise the increase in length on the air side was much smaller than on the water side.

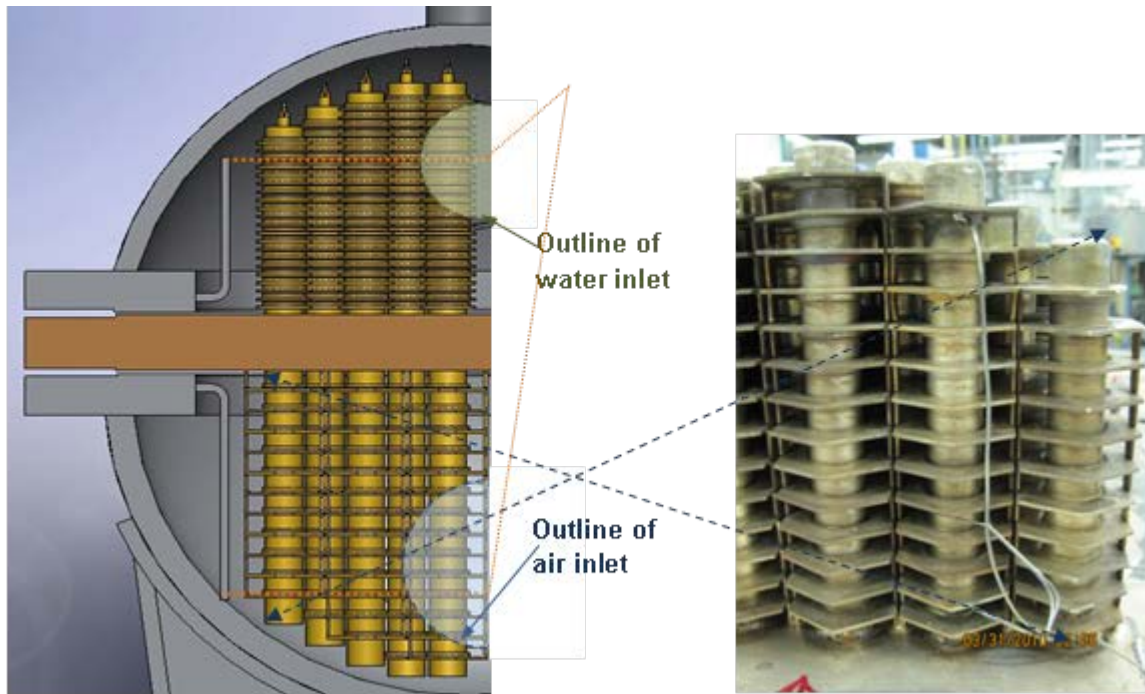
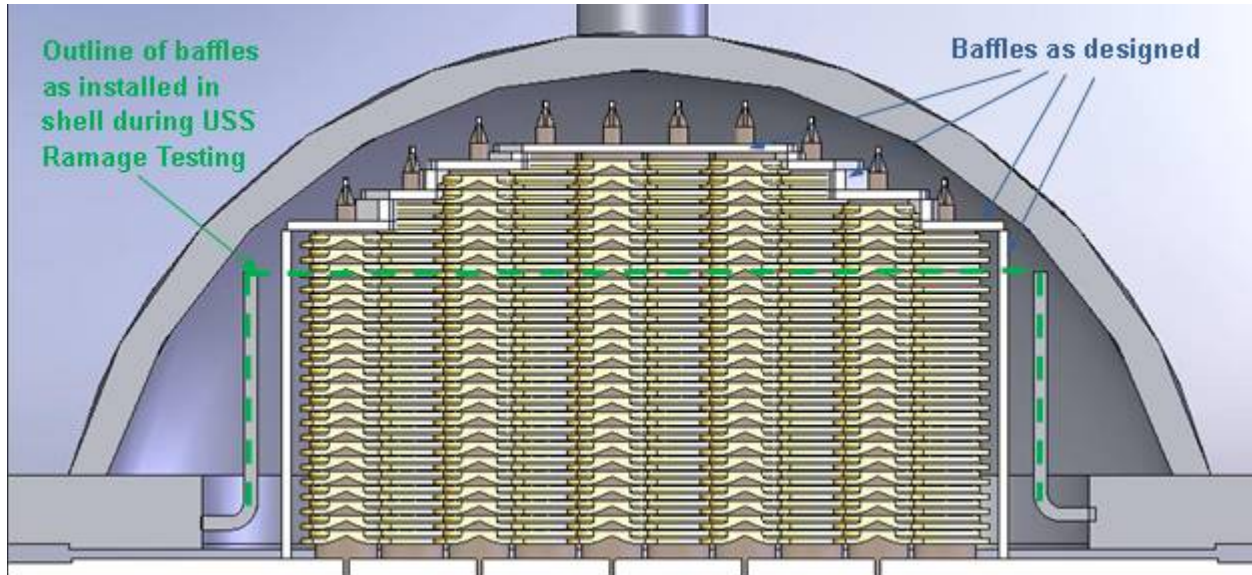


Figure 5- 1 Solid Model Extended Pipes & Fins as Fitted

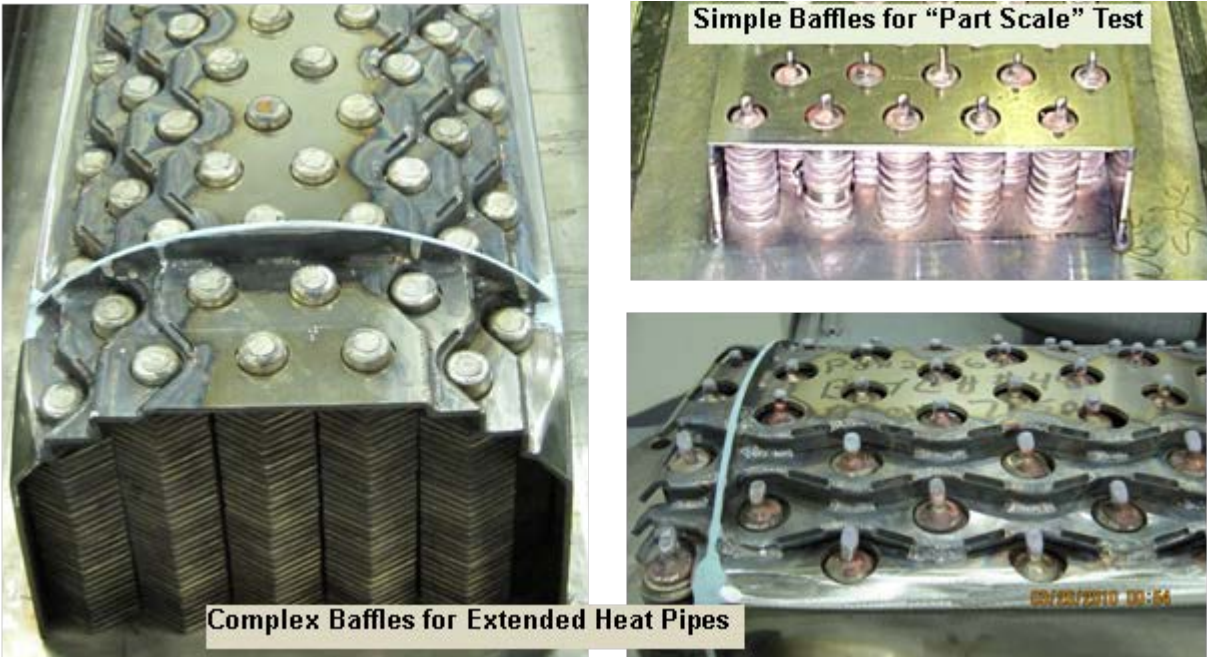


## 5-2 Baffles for Extended Heat Pipes



**Figure 5- 2 Cross Section Showing As-Designed Baffles Fitted in Shell**

Figure 5-2 shows the water-side baffles as fitted to the extended pipes and fins. It also shows the outline of the baffles that were installed during the testing aboard the USS Ramage. This step resulted in some reduction in fins to clear the baffles. Fitting the baffles, and the ducts, was problematic because the inside of the shell varied from the smooth arcs and radii depicted in the solid model of the shell. This was especially difficult at the ends where the dome of the shell required significant alteration to the as-designed baffles. The complexity of the baffle shape required to clear the fins and fit into the shell are clearly seen in Figure 5-3, especially when compared with the simple box shape of the baffles used in the Part Scale test which are shown in the upper right of the figure.



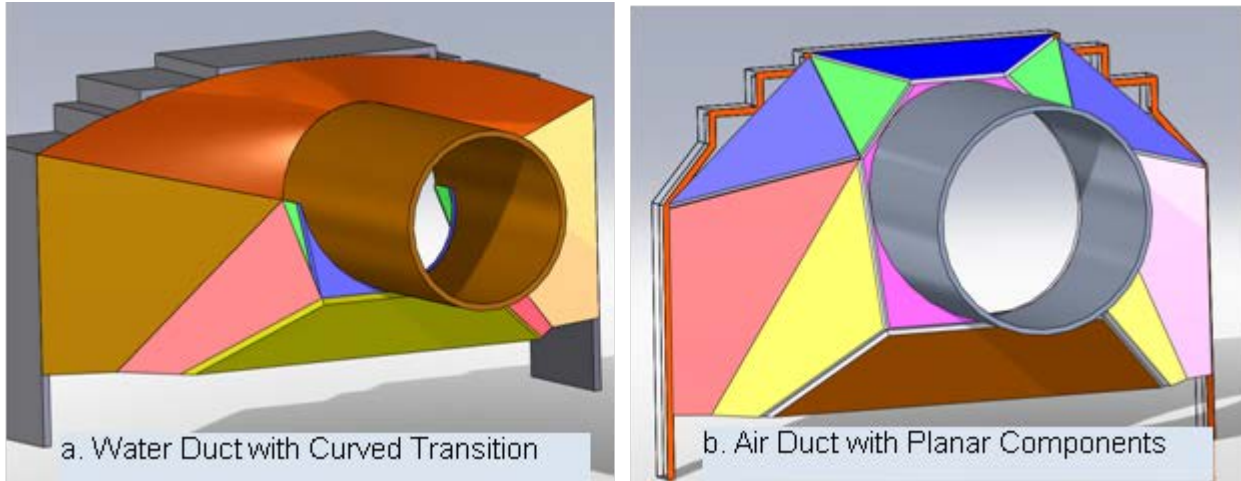
**Figure 5- 3 Complexity of Baffles for Extended Heat Pipes**

### **5-3 Ducts for Complex Baffles**

Figure 4-1 in section 4 shows a side view of the air and water inlets with the simple baffles on the shorter heat pipes tested at Wyle. Figure 5-1 shows a cross section of the current design with the water and air inlets highlighted to show their relative area superimposed on the extended length heat pipes and fins. With the dramatic change in flow cross section from the inlet to the baffles, ducts are required to direct the inlet flows to the baffles, thereby effecting a reasonably uniform flow field, preventing flow from bypassing the baffles and the heat pipes, and reducing turbulence and recirculation zones.

For the short heat pipes, the baffle cross section (upper right of Figure 5-3) was rectangular, so the design and fabrication of the duct was straightforward. For the extended length heat pipes the baffles' cross section is a castellated shape (or stair step, see Figure 5-2) which is a more difficult transition.

The initial design used a curved transition piece as shown in Figure 5-4a. This was a relatively easy shape to generate in a solid modeling program, and proved possible to form in a mockup duct made from relatively thin, flexible styrene. The shape is a complex conic surface that proved impossible to form in thick stainless or copper nickel without resorting to hot forging techniques and complex tooling (or wire EDM). The design shown in Figure 5-4b, while more tedious to design in a solid model, proved easy to assemble. The many small pieces were generated by a numerically controlled water jet cutting tool which was programmed directly from the solid model output.



**Figure 5- 4 Duct Designs**

## Chapter 6 - Fabricate Full Scale HP-BAC

The fabrication and processing were described in detail in the Final Report of August 29, 2008, Appendix-C. This section only reports changes or unique aspects of the extended heat pipe BAC compared to those previously reported for the part scale 25 pipes HP-BAC.

### 6-1 Baffles and Ducts

As already seen in Figures 5-2, 5-3, and 5-4, and in their completed form in Figure 6-1 below, the baffles and ducts were somewhat intricate assemblies of many parts with non-simple shapes. While not technically challenging, the design, fabrication, assembly and fitting were extremely time consuming.

The use of numerically controlled water-jet cutting machines enabled the efficient fabrication of the many parts that went into the ducts and baffles. The parts were designed and fitted as solid models in Solid Works. Flat drawings were generated from these models then converted to DXF format which were directly input to the software controlling the cutters. Figure 6-2 shows one of these drawings for the flat plate pieces for the water side baffle. The vertical riser sections were cut in the same manner from bar stock that was as thick as the height of the riser. Without numerically controlled water jet cutting, the cost of fabricating the baffles would have been prohibitive.

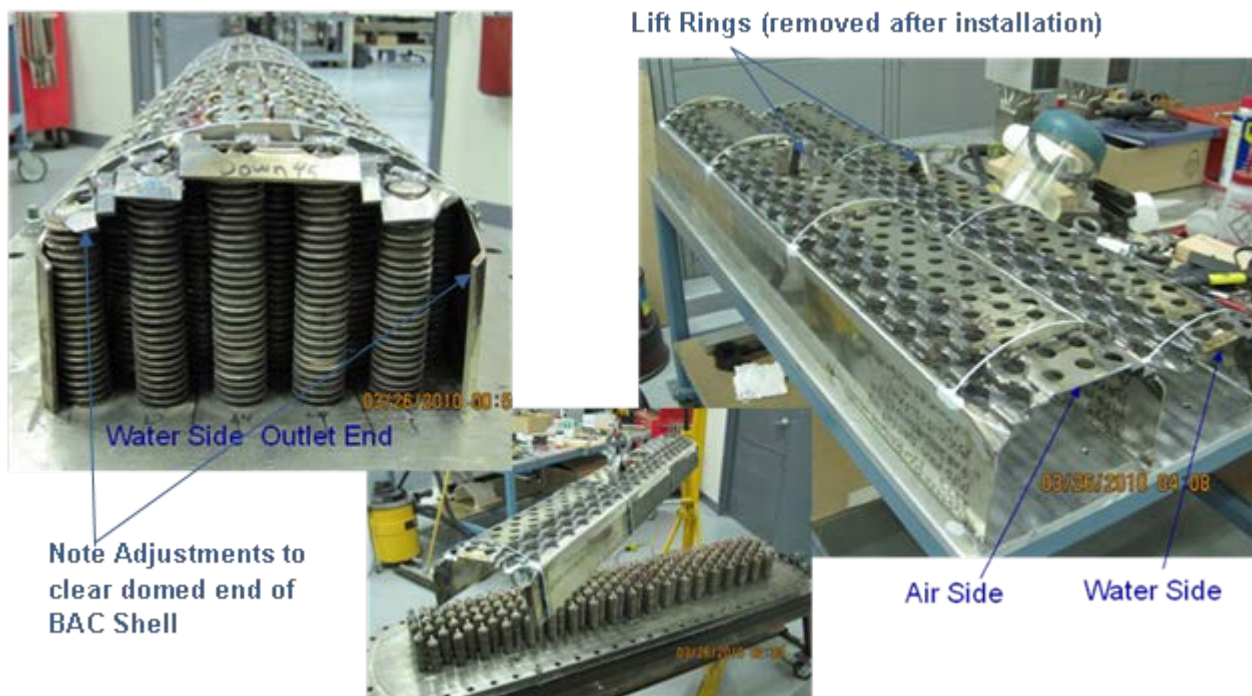


Figure 6- 1 Baffle Assemblies for Extended Length Heat Pipes, As-Built

## **6-2 Fin Brazing**

The water side fins are wired to spacers prior to and during brazing. The air side fins are self spacing and do not require spacers. Since their integral spacer tabs would interfere with air flow if not properly oriented, the air side fins must be constrained to prevent them from rotating due to transport vibration or thermal effects prior to and during brazing. For the 25 pipe coupon redesign test, the fins were tack welded to prevent unwanted movement. For the full scale assembly, a binder was used to keep them in place. This binder has been routinely used by Thermacore for high temperature vacuum brazing on other products and was known to decompose and be eliminated by the vacuum system before the braze melted and not interfere in any way with the brazing process

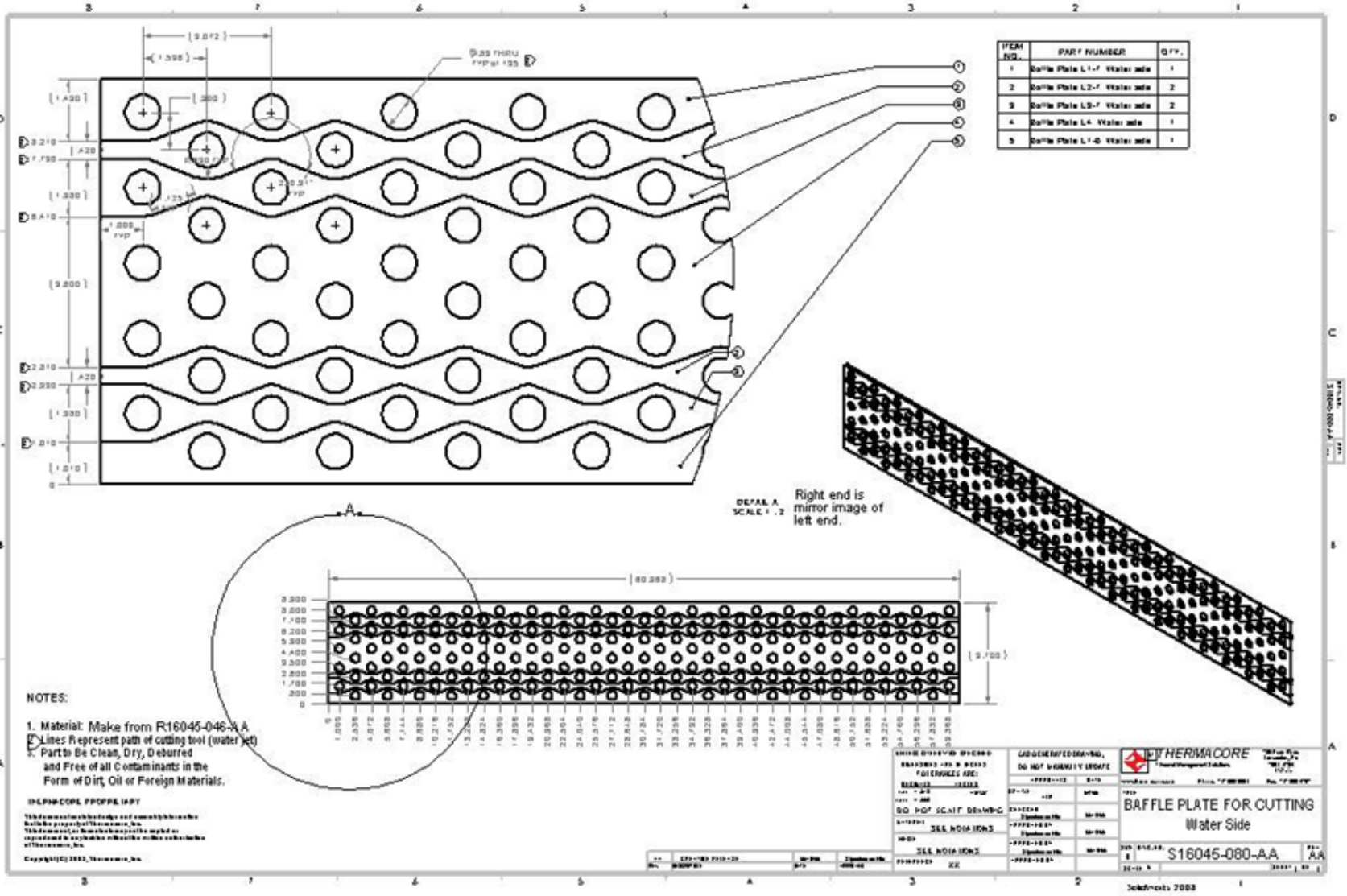


Figure 6- 2 Cutting Diagram for Water Side Baffle Plates



**Figure 6- 3 Water-Side View of HP-BAC Outside the Braze Furnace**

The large furnace used for brazing the HP-BAC maintained a 1 torr blanket gas rather than the very hard vacuum that Thermacore normally employed. Evidently the gas interfered with the decomposition/venting of the binder. Instead of being shiny, the heat pipes were visibly dirty. Figure 6-3 shows the water side of the HP-BAC assembly going into the furnace, and Figure 6-4 shows the heat pipes with residue after the furnace run. After learning of the 1 torr blanket gas it was assumed that the products of decomposition had not been removed and instead left a residue that was deposited on the heat pipes and fins. This residue interfered with the flow of the braze material, and it did not meet our standards.

A series of experiments were conducted to determine how to best clean the dirty surfaces. Tests were conducted on a few fins that were loose or so poorly brazed that they could be removed by hand, to ensure that the process would remove the residue. Segments of the shorter heat pipes that had been used on the part scale tests were subjected to the cleaning procedure to show that the ultrasonic's would not affect the sintered wick. Figure 6-5 shows these heat pipe segments that had been partly immersed in an ultrasonic cleaning bath. The figure clearly shows that the cleaning was effective, and the segments were then examined to verify that the ultrasonic's did not loosen any of the sintered powder.

With the process defined, a large tank was constructed, large ultrasonic emitters were rented, and the entire subassembly was cleaned. Figure 6-6 shows the assembly being immersed in the tank. After cleaning the braze run was repeated without the binder and excellent brazes were obtained.



**Figure 6- 4 Water Side Heat Pipes with Residue after First Furnace Run**



**Figure 6- 5 Effective Cleaning**





**Figure 6- 6 HP-BAC Tube Sheet Being Immersed in Ultrasonic Cleaning Tank**



**Figure 6- 7 Heat Pipe Processing**

### 6-3 Heat Pipe Processing

Heat Pipe processing followed previous practice. The pinch off tool developed for the uniform length heat pipes had been designed so it would work with multi-length pipes, but had to be modified to do an efficient job, and to permit even shorter pinch off tube finished lengths. The left side of Figure 6-7 shows the hydraulic pinch off tool in position.

With commercial copper/water heat pipes, it is easy to pinch the copper fill tube with simple hand tools, and the pinch produces a cold weld that will hold vacuum until it is convenient to solder it off. This makes it easy to make multiple pinches while “burping” the heat pipe. The copper nickel used in the BAC required a multistep pinch-off followed immediately by a weld-off. This necessitated that a valve be installed for the “burping” process. In addition to being cumbersome for the process, if valves were installed on more than one row of heat pipes, they interfered with the pinch-off tool, which limited the number of pipes that could be pumped down at one time. A simple improvement was to replace the valve with a length of small diameter copper tubing. The right side of in Figure 6-7 shows a pinched off copper extension next to a bulky valve.

### 6-4 Instrumentation

After the Wyle test it was recommended that intrinsic thermocouples be installed on subsequent tests to preclude the erroneous measurements discussed in Sections 4-1.1 and 4-1.4. For the temperature range, and the need to bring thermocouple leads thru a seal in the pressure shell, it was necessary to use sheathed thermocouples. To make an intrinsic connection it would be necessary to cut off the sheathing which would compromise both the thermocouple insulation and the pressure seal.

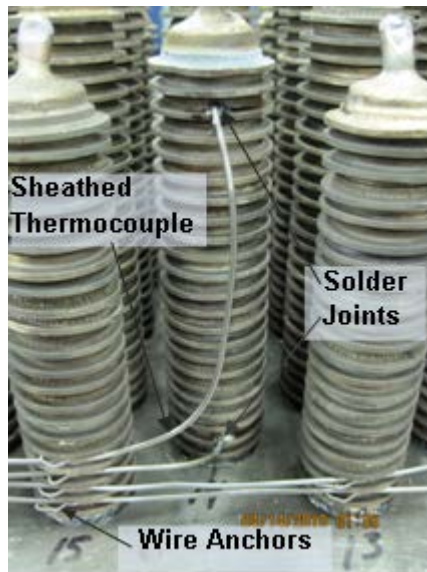


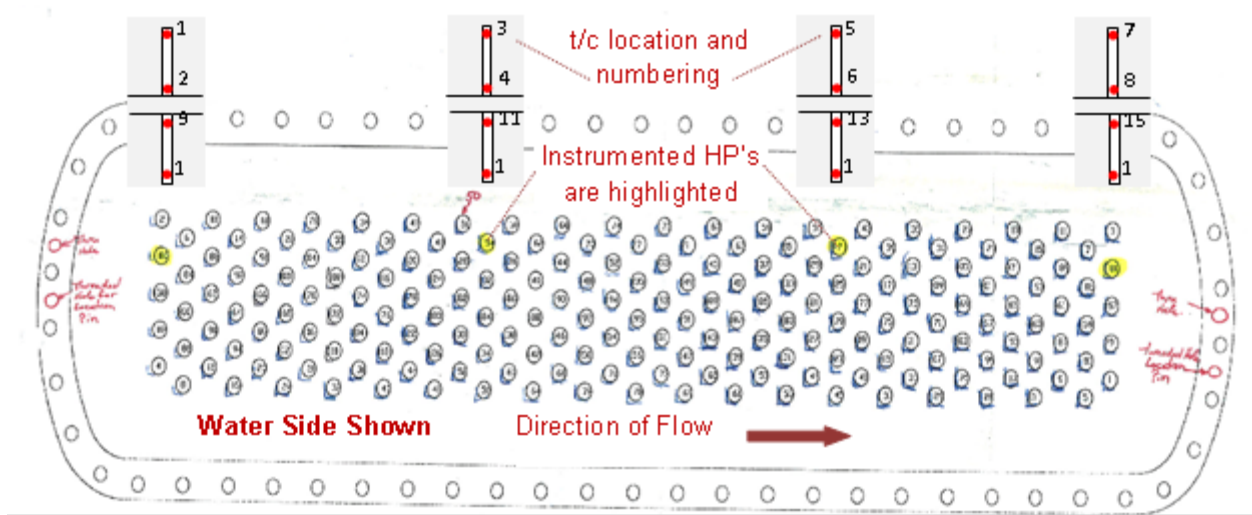
Figure 6- 8 Thermocouples

To minimize the error from measuring a surface temperature when immersed in a surrounding fluid of significantly different temperature, the installation was made more robust. A hole was drilled thru the base of a fin where a t/c was to be attached. The depth of this hole is approximately equal to the diameter

of the t/c sheath, so it functions as a thermocouple well. To maintain pressure against the surface, as well as exclude fluid from the well, the thermocouples were soldered into place. The thermocouples were further supported by being wired to an adjacent heat pipe to minimize the bending moments that can be applied to the solder joint by hydraulic forces. Figure 6-8 shows sheathed thermocouples, wire anchors and solder joints anchors on a water side heat pipe.

## Chapter 7 - Land Based Test of Full Scale HP-BAC

### 7-1 Thermocouple Placement



**Figure 7- 1 Thermocouple Placement and Numbering**

Figure 7-1 shows the location of the instrumented heat pipes and the numbering of the thermocouples attached to them. The figure looks down on the water side with the flow from left to right. The sketches at the top of the figure show a schematic cross section of the heat pipe with the water side at the top. The t/c numbering on this figure was carried thru and used on the data logging and screen shots for the land based testing at Stork. The photo in Figure 6-8 shows t/c#3 at the top and #4 at the bottom attached to the heat pipe that is numbered 54 in Figure 7-1. The numbers (written in magic marker on the plate) that can be read in the photo, designate the number of heat pipe rows from the flow inlet end. The instrumented heat pipes are generally in the first row of each sector, where the number of fins per inch on the air side changes.

Figure 7-2 shows the water side thermocouples being pulled thru the Conax seal on the water-side instrument port. The air side shell has already been installed in this photo. The thermocouples are carefully worked thru the graphite pieces within the seal until the excess cable is outside the seal. Then the finial lengths will be carefully pulled as the shell is lowered.

The photo shows one of the final steps in the HP-BAC assembly. It is already on the shipping pallet. The shells were then bolted together, and tightened to both torque and sequence specifications. The Conax seals were tightened. End plates were bolted to the flanges and the unit was pressure tested. Then the unit was shipped to Stork East-West Technology Corp. in Jupiter FL for full scale land based testing.



**Figure 7- 2 Thermocouples being pulled thru Conax seal on Water Side Shell**

**7-2 Testing at Stork East-West Technology Corp.**

**7-2.1 Test Setup**

Testing took place during the week of May 10, 2010. Figure 7-3 shows two views of the test setup. Note that unlike the previous testing at Wyle, the HP-BAC was insulated for this test; it used the same fitted insulation that was used on board the Ramage.



**Figure 7- 3 HP-BAC Test Setup at Stork East-West Technology Corp.**

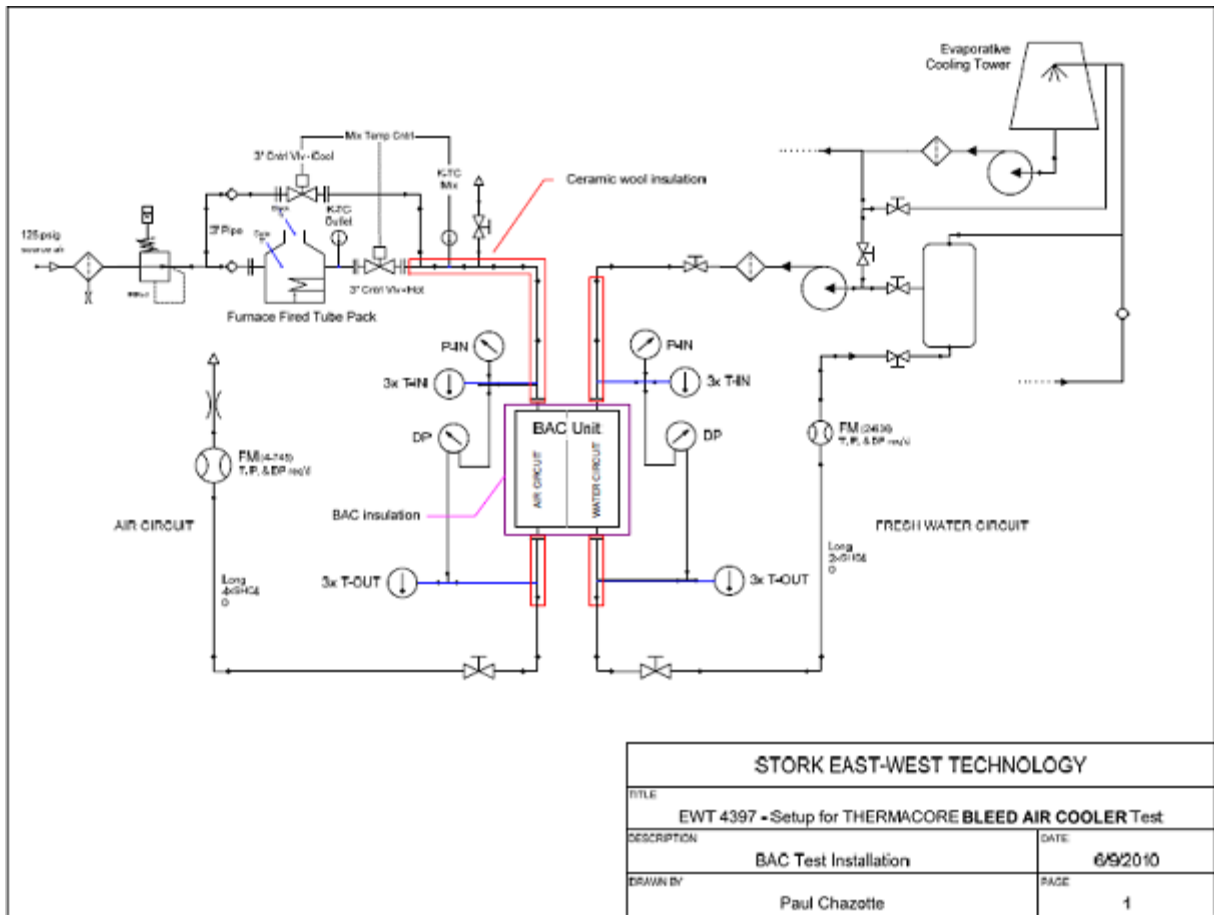


Figure 7- 4 Schematic Diagram of Test Setup

**Table 7- 1 Test Equipment and Calibration Data**

Item Description	Manufacturer	Where Used	Model	Serial	EWT Asset #	Cal Date	Cal Due Date
Pressure Transducer	Data Sensors Inc.	Water In	PB519S-4	2478	2652	5/7/10	11/3/10
Signal Conditioner	Dataforth	Water In Transducer	DSCA38-02	29744-8	3-1712	8/19/09	8/19/10
DP Gauge	Barton	DP across water circ.	0 - 400	200-37562	4-1232	5/13/10	11/9/10
Venturi	Hyspan	Water Flow	BR12478	n/a	2511	6/15/09	6/15/10
DP Gauge	Bailey	Across water venturi	PTSDDC1221101M1	56722	4-4201	12/2/09	5/31/10
Pressure Transducer	Data Sensors Inc.	Air In	PB519S-4	2676	2650	5/7/10	11/3/10
Signal Conditioner	Dataforth	Air In Transducer	DSCA38-02	15391-5	4-4061	5/7/10	5/7/11
DP Gauge	Bailey	Across Air circ	PTSDD1221A2100	105625	4-4199	5/7/10	11/3/10
Venturi	Hyspan	Air Flow	BR-29745-64-41	416181	4-1242	3/31/10	3/31/11
DP Gauge	Teledyne	Across Air Venturi	2212	869804	T100	2/2/10	8/1/10
Signal Conditioner	Dataforth	DP transducer across air venturi	DSCA38-02	11479-28	4-4163	5/7/10	5/7/11
Pressure Transducer	ACI	Static Pressure Air Venturi	PT255-50G1C1A	L1596-003	4-1318	1/20/10	7/19/10
A-D Board	M.C. Inc.	Data Acquisition	PCIM-DAS16JR/16	n/a	2-2072	5/6/10	11/2/10
D-A Board	M.C. Inc.	Data Acquisition	PCIDAC6702	n/a	2-2071	5/6/10	11/2/10
Multiplexer Board	M.C. Inc.	Data Acquisition	CIO EXP 32	n/a	3-5030	5/6/10	11/2/10
Multiplexer Board	Computer Board	Data Acquisition	CIO EXP 32	n/a	2674	5/6/10	11/2/10

Figure 7-4 provides a schematic diagram of the test setup while Table 7-1 defines the instruments employed. Stork's test report R4297, a copy of which was forwarded to NSWC on June 14, 2010 provides additional information and photos. The test setup was started on April 26. After solving a variety of problems and replacing pumps and other components, a representative half flow test was conducted on May 12. Full flow tests were conducted the following day.

## 7-2.2 Test Results

Test conditions that closely met the test parameters for Case 1 (550°F) were achieved early on the afternoon of May 13. Figures 7-5 and 7-6 are screen shots of the Stork monitoring program taken during periods of stable, steady state operation. These data were used for further analysis.

Case 2 was supposed to be at 700°F, but the highest temperature that could be maintained with the available equipment turned out to be 630°F. A data set was obtained at 661°F inlet air temperature, but this higher temperature was the result of reduced air flow and was not a useful data set. Figures 7-7 and 7-8 respectively show stable data taken at 620°F and 630°F.

Additional efforts were made to achieve higher air temperatures at rated flow, but this was beyond the ability of the available equipment. While not reaching the desired test temperature, these data were deemed adequate to achieve the test goals and the testing was concluded.

### **7-2.3 Comments about Figure 7-5 through 7-9**

Figure 7-9 was assembled to try and simplify the test data sheets of Figures 7-5, 7-6, 7-7, 7-8 and some other collected test data points these Figures are not shown in the report:

Each of the 7 data runs are separated by a gray bar. The 4 data runs shown above Figures 7-5, 7-6, 7-7, 7-8 are marked in Figure 7-9. The black lines in figure 7-9 represent the tube sheet separating the air side from the water side. The left side shows the inlet temperature values for both the water and air. The right side shows the temperature outlet values leaving the heat pipe heat exchanger. The temperature values under the different fins per inch sections are the readings from the thermocouples that were attached at the beginning of the different modules. The picture on the right shows the thermocouple locations where the Top (T) and Bottom (B) are located. The bottom set of information in the figure with a black line is the Thermocouple identifying nomenclature.

**The Key Temperature Numbers To Look At In Figure 7-9 Are The Values Of The Water Side Wall Temperatures. The Main Goal Of This Project Was To Have The Wall Temperature Of The Heat Pipe To Stay Below 150°F, The Temperature Where Scaling Begins To Form. This Was Accomplished!**



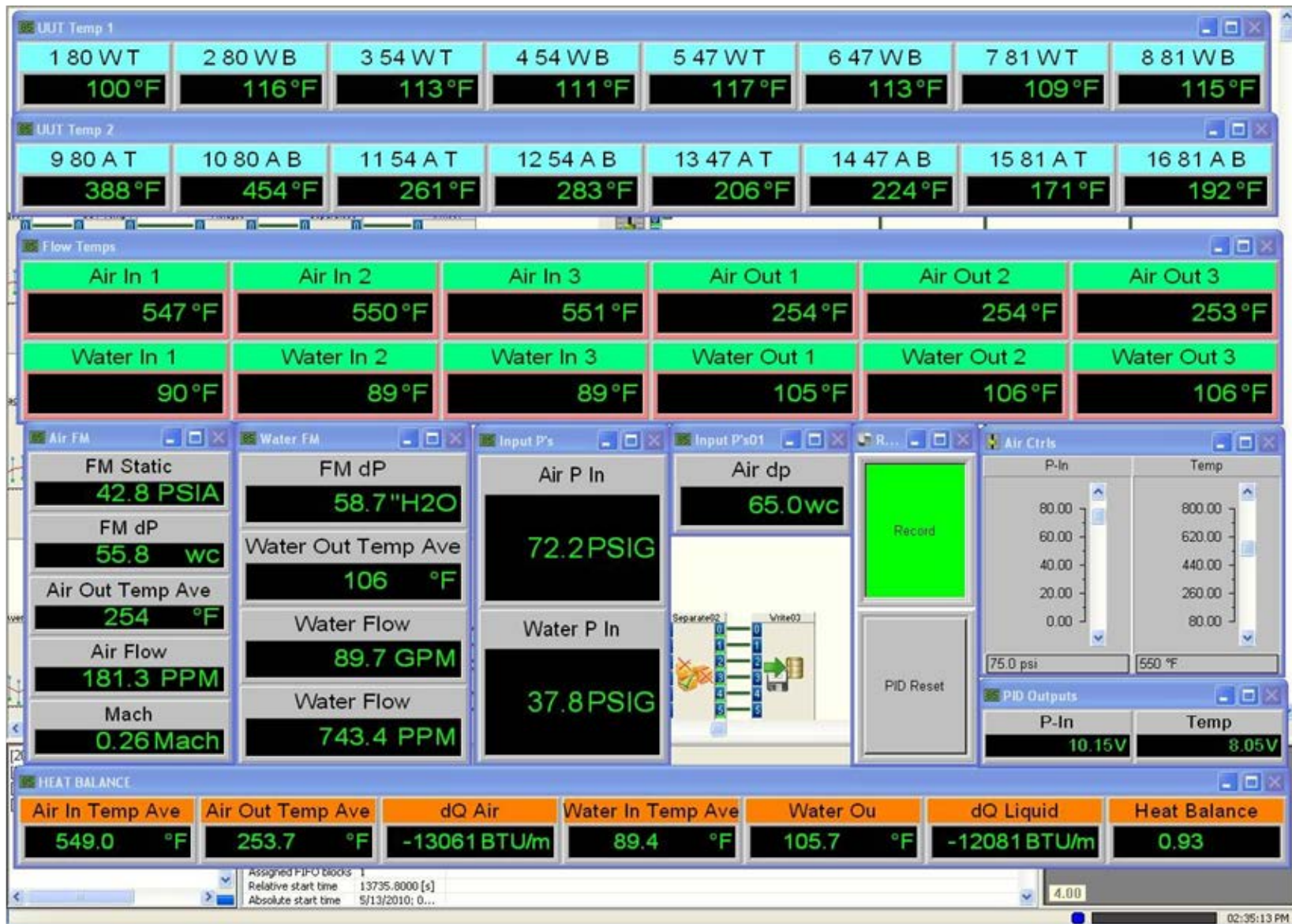


Figure 7- 5 Data Set 1 at 550 ° F (2:35 PM 5/13/10)

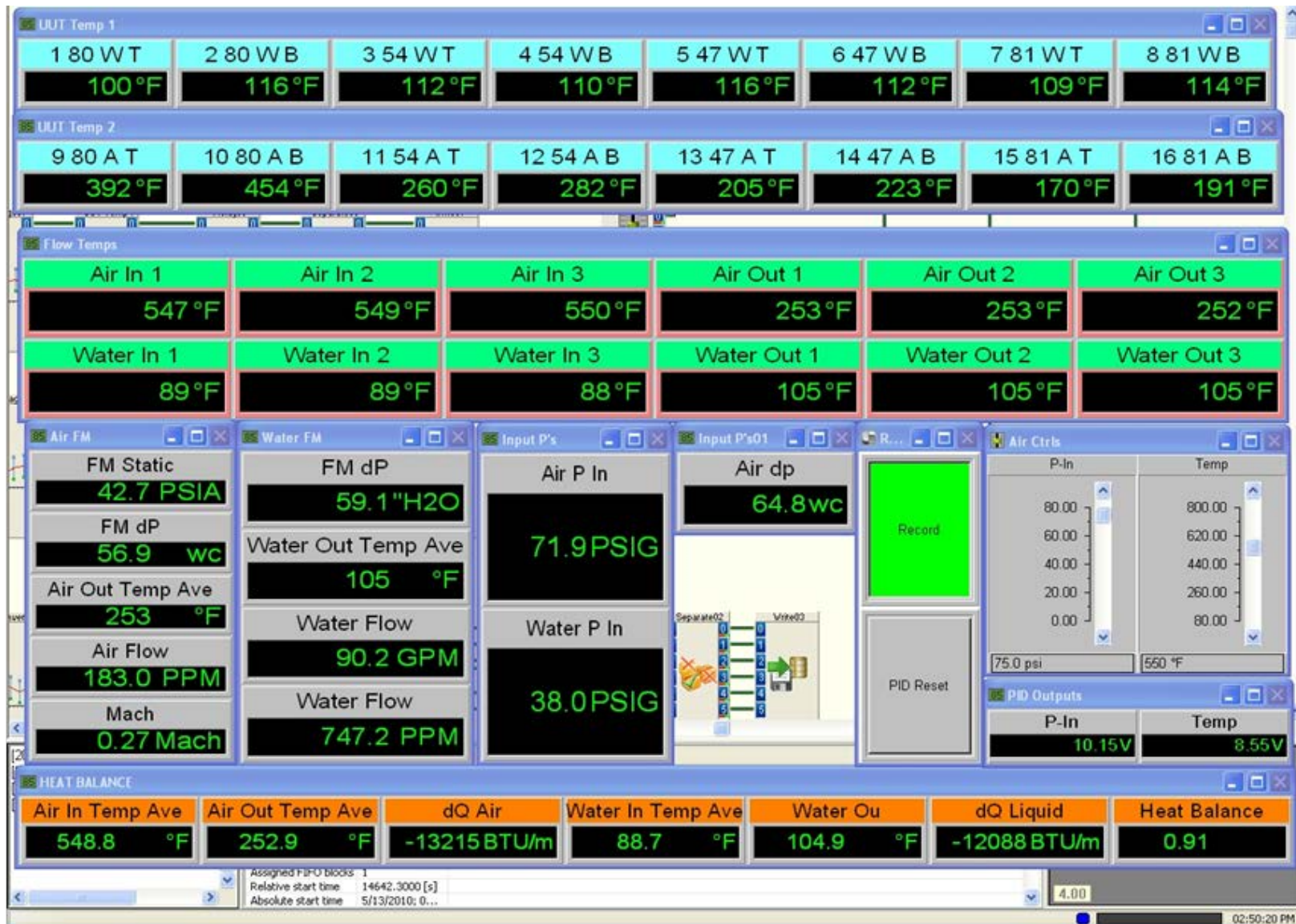


Figure 7- 6 Data Set 2 at 550 ° F (2:50 PM 5/13/10)

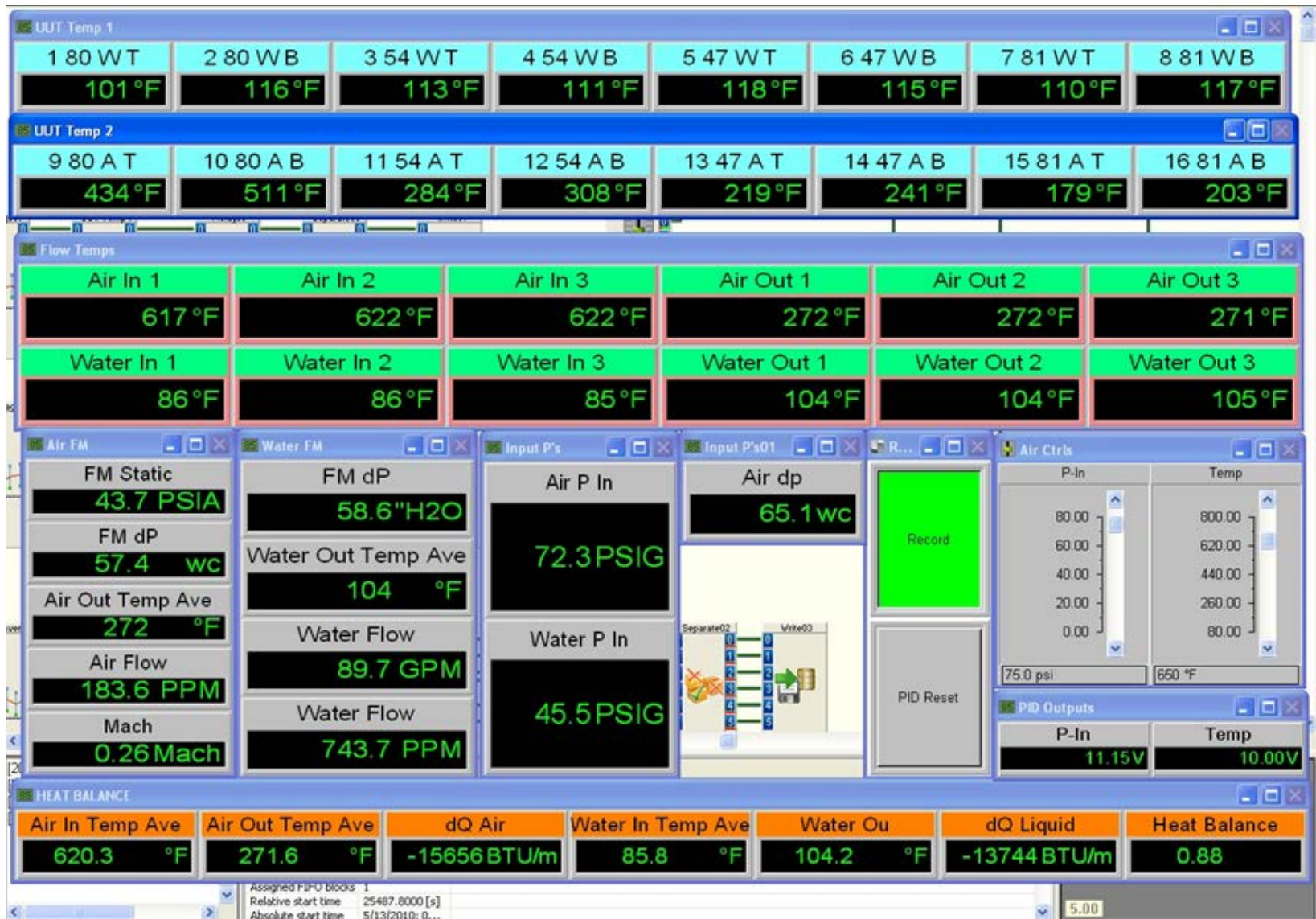


Figure 7- 7 Data Set 3 at 620 ° F (5:51 PM 5/13/10)

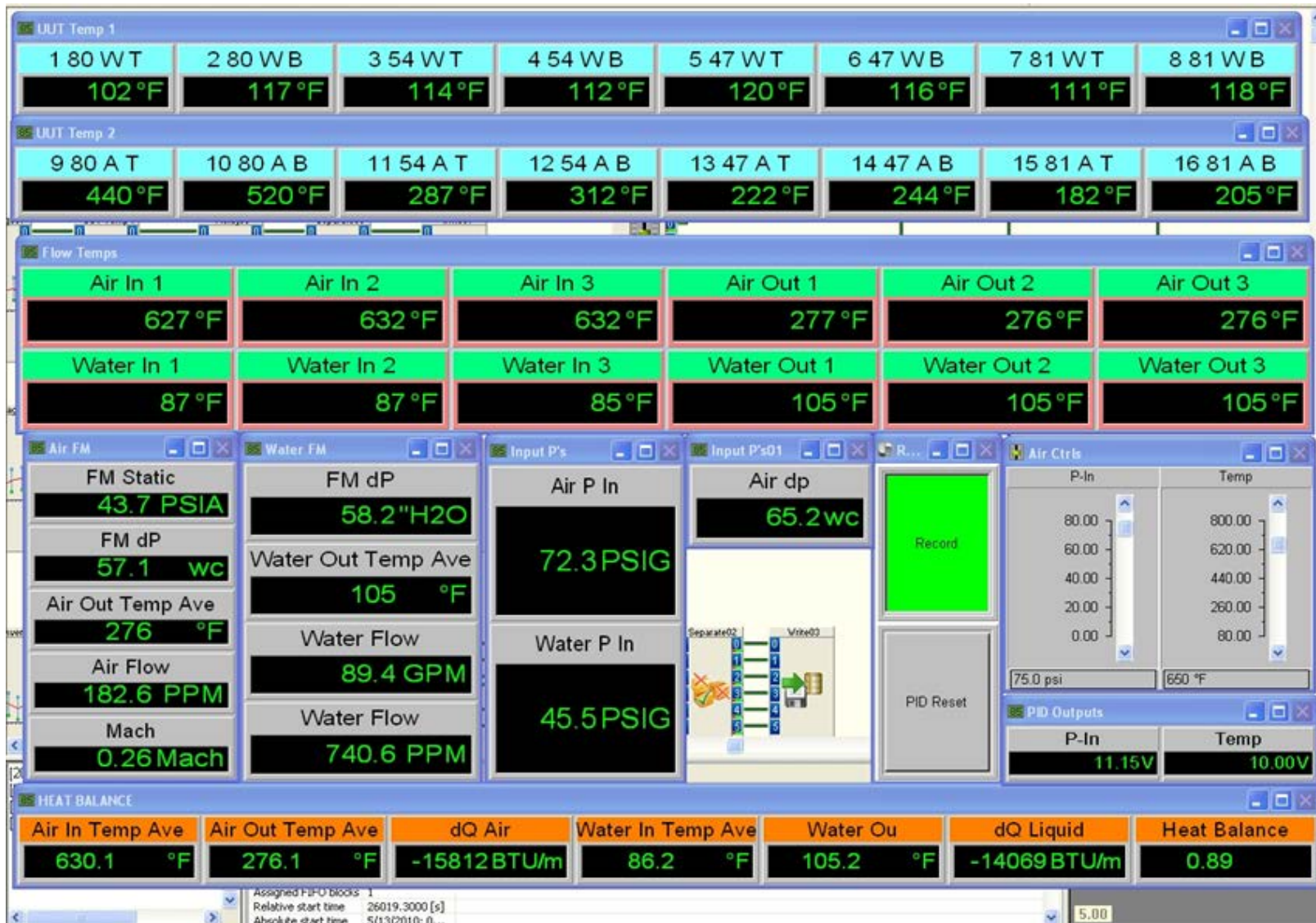


Figure 7- 8 Data Set at 630 °F (5:59 PM 5/13/10)

The full scale heat pipe cooler was tested at Stork East West Technology Corp the week of May 10, 2010. The data below shows that the cooler was performing at about 85% of the modeled power. The outlet temperatures were also higher than the modeled values but within the need performance requirements to operating in the bleed air system. The main requirement of controlling the wall temperature of the water side pipes below 150 oF was very successful in this land based test. Based on the data below reinstalling the full scale cooler back onto the Ramage would allow the technology to be qualified at sea validate that it is capable of significantly reducing the scaling in the bleed air coolers. Below the data is a Summary of the instrumented heat pipe in the different modules measuring the wall temperatures of the heat pipes air evaporator section and the water condenser section. Four thermocouples were attached to each of the 4 instrumented heat pipes 2 on the water side and 2 on the air side. One can see that the temperature were significantly below the 150 temperature.

		Heat Pipe Thermocouples										
		2 fins per inch		3 fins per inch		5 fins per inch				A typical instrumented heat pipe		
						Module 3 first row pipe #47						
12:51 PM	water in	90	101	111	115	107	104					
			115	110	111	113						
	air in	552.8	384	247	192	163	238					
			449	268	208	178						
2:35 PM	water in	89.4	100	113	117	109	105.7					
			116	111	113	115						
Fig 7-5	air in	549	388	261	206	171	253.7					
			454	283	224	192						
2:50 PM	water in	88.7	100	112	116	109	104.9					
			116	110	112	114						
Fig 7-6	air in	548.8	392	260	205	170	252.9					
			454	282	223	191						
5:37 PM	water in	87.5	102	114	120	111	105.7					
			118	112	115	118						
	air in	621	433	283	218	179	269.6					
			510	307	240	201						
5:51 PM	water in	85.8	101	113	118	110	104.2					
			116	111	115	117						
Fig 7-7	air in	620.3	434	284	219	179	271.6					
			511	308	241	203						
5:59 PM	water in	86.2	102	114	120	111	105.2					
			117	112	116	118						
Fig 7-8	air in	630.1	440	287	222	182	276.1					
			520	312	244	205						
6:21 PM	water in	86.1	100	113	118	110	104.4					
			117	111	115	117						
	air in	620.7	434	284	220	181	274.1					
			513	309	242	204						
			1-80-W-T	3-54-W-T	5-47-W-T	7-81-W-T						
			2-80-W-B	4-54-W-T	6-47-W-B	8-81-W-B						
			9-80-A-T	11-54-A-T	13-47-A-T	15-81-A-T						
			10-80-A-B	12-54-A-B	14-47-A-B	16-81-A-B						
			Heat Pipes with Thermocouples									

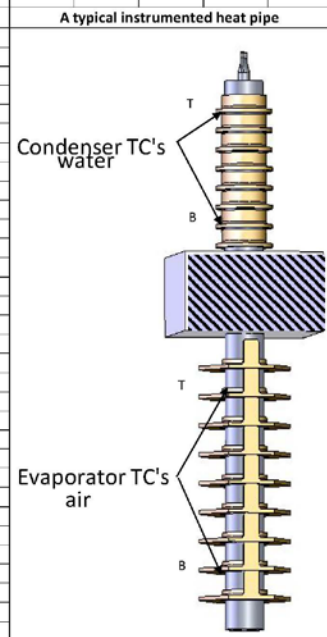


Figure 7- 9 Summary Sheet of Stork test Data and Thermocouple

### 7-3 Reduction and Evaluation of Test Data

The analytic model was run using the exact input temperature and flow values that were used in each test case, and then the calculated outputs were compared with the measured outputs. The results are shown in the comparison table presented as Figure 7-10.

The “Power Ratio” and the “Air dT Ratio” columns show that over a considerable range of test conditions, the performance measured in the test were consistently about 85% of those predicted by the analytic model.

It should be pointed out that the measured results were very close to what the analytic model was predicting before the model was recalibrated to match the Wyle data. While the project Engineer expressed reservations about the accuracy of the Wyle data (see section 7.5.2 of the Final Report Appendix-C which has been reproduced in Section 4-1.1 of this report), both the Thermacore Project Engineer, and the NSWC Principal Investigator (both of whom observed the Stork testing) agree that the Stork data is rock solid. This test really confirmed the analytic model, and provided data to adjust the empirical constants in the model.

In the initial test aboard the Ramage (June 2005), the HPBAC removed 42% as much heat as the shell-and-tube BAC. After baffle plates were installed, the HPBAC removed 60% as much heat as the shell-and-tube HX in tests aboard the Ramage (7/27/05). With the design improvements, the current HPBAC achieved 80% of the performance of the shell-and-tube HX. It should be noted once again, that the design objective of the HPBAC cooler is to maintain the seawater side surfaces below the 150°F salt scaling temperature and thus reduce the maintenance and system support costs associated with calcareous deposits in the shell-and-tube BAC. Lowering the temperature increases the thermal resistance, so a HPBAC would have to be larger than a given shell-and-tube BAC in order to match its thermal performance. The demonstrated performance, while not a one-to-one replacement for the existing BACs, is adequate to allow their use on shipboard testing.

If shipboard testing confirms that the seawater side temperature reduction achieves the projected reduction in scaling and its associated maintenance and system support costs, then the analytic model would allow the design of a HPBAC that would be a direct performance replacement.

### 7-4 Analytic Model ReCorrelation

After the Wyle test, an empirical correction factor (ECF) was included in the heat transfer correlations as described in Section 4.1 of this report. The best match for the Wyle data was achieved for a value of 1.41 for both the air and water Empirical Correction Factors. ( $ECF_{\text{water}} = ECF_{\text{air}} = 1.41$ ) With the Stork test data, the ECFs were eliminated, i.e. reset to 1.0.

The analytic model originally used a heat pipe resistance of 0.070 °C/watt. After the Wyle test this was reset to 0.024 °C/watt, which was its minimum theoretical value. Using the Stork data, the model best matches the test results with a value of 0.045 °C/watt. These results are summarized in Table 5.

It is of interest to note that the initial testing aboard the Ramage the HPBAC achieved 58% of its calculated performance and after adding the baffles it achieved 83% of its calculated performance. Using the same model adjusted for the longer heat pipes, the HPBAC tested at Stork achieved 110% of its calculated performance. The re-correlated model is still slightly conservative, calculating about 1% less transport than was actually achieved.

Test/Model ID	Air in		Air Out				Water In		Water Out				Power		Power Ratio	Air delta-T				Air dT Ratio
	°C	°F	Model °C	Model °F	Test °C	Test °F	°C	°F	Model °C	Model °F	Test °C	Test °F	Model kW	Test kW		Model °C	Model °F	Test °C	Test °F	
Half Flow 5/12	287.8	550	60.5	140.9		198	32.9	91	39.95	103.8		100	162.1	138.3	85.32%	227.3	409.1		352	86.04%
2:35 at 550°F	287.8	550	93	199.4		253.7	31.9	89.4	43.75	110.75		105.7	275.7	229.7	83.32%	194.8	350.6		296.3	84.51%
2:50 at 550°F	287.1	549	93	199.4		252.9	31.5	88.7	43.35	110.02		104.9	277.2	232	83.69%	194.1	349.6		296.1	84.70%
5:51 at 620°	326.8	620.3	101.67	215		271.6	29.9	85.8	43.77	110.8		104.2	322.7	275	85.22%	225.13	405.3		348.7	86.04%
5:59 at 630°	332.3	630.1	103.16	217.7	135.6	276.1	30.11	86.2	44.22	111.6		105.2	328.4	278	84.65%	229.14	412.4		354	85.84%
MODEL at 700°F	371.1	700	112.54	234.6		302.43	30.11	86.2	46.04	114.8			370.6	312.93		258.56	465.4		397.57	
MODEL at 900°F	482.2	900	140.75	285.35		374.93	30.11	86.2	51.14	124.05			491	414.60		341.45	614.65		525.07	
															AVG				AVG	85.43%

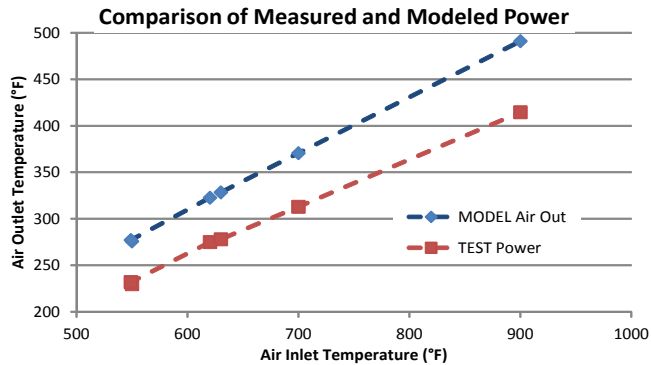
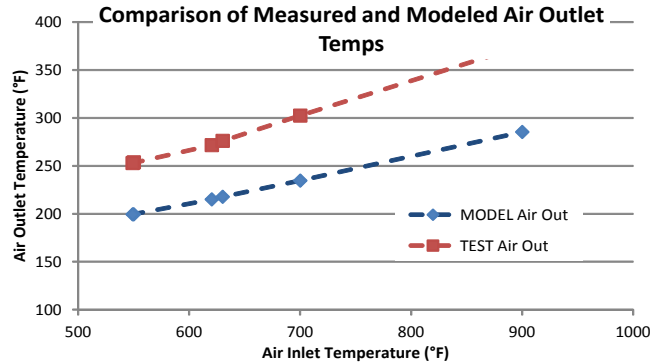
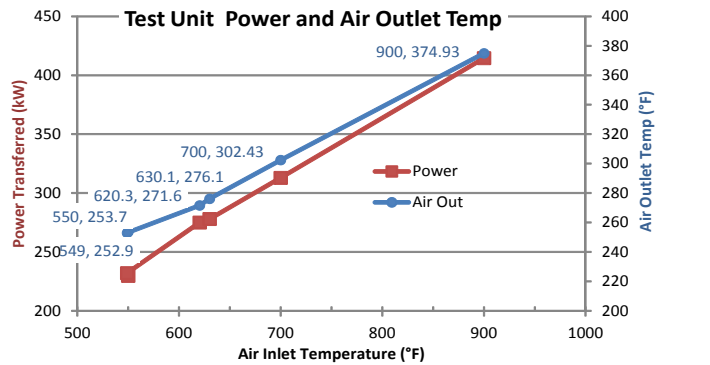


Figure 7- 10 Reduction of Test Data and Comparison with Analytic Model Predictions

**Table 7- 2 Ratio of Measured to Calculated Heat Transport vs. Heat Pipe Resistance**

Heat Pipe Resistance	0.024°C /watt (Wyle)	0.070 °C/watt (orig Model)	0.045 °C/watt (recorrelated model)
$\frac{kW_{\text{measured}}}{kW_{\text{calculated}}}$	90.9%	110.6%	101.6%

**7-5 Conclusions and Recommendations**

1. The performance of the HPBAC in the land based testing is adequate to proceed with shipboard testing. The main goal of having the tube wall temperatures stay below the 150°F temperature, see Figure 7-9, was accomplished.
2. The actual reduction in fouling, hazmat reductions, and the required maintenance as revealed by shipboard testing will determine whether the HPBAC should be moved to a production phase.
3. The analytic model has been validated by the test results and benchmarked to the test data. It can be used to design a (physically larger) HPBAC that will provide a one-to-one performance replacement for the shell-and-tube BAC.
4. The present fabrication methods are impractical and uneconomical for a production HPBAC. A Production Cost Analysis report of June 2, 2008 Appendix – E by Thermacore suggested potential cost improvements which should be considered when making a production decision following successful shipboard tests.
5. Since this technology was proposed the Navy struggles to afford back fit technologies so the primary focus for transition would be new ship construction along with commercial applications such as the hot geothermal, molasses manufacturing, and other manufacturing applications that have a need to control condenser wall temperatures during cooling.



## Chapter 8 - References

- [1] Resource Conservation and Recovery Act (RCRA) passed by Congress in 1976. Hazardous wastes are defined under RCRA in 40 CFR 261
- [2] Chapter 9 OPNAVINST 5090.1C, Environmental Compliance Afloat, Chapter 22, 30 October 2017
- [3] NSWCCD Demonstration test plan of 24 May 2004 for ESTCP “Elimination of Acid Cleaning of High Temperature Salt Water Heat Exchangers”
- [4] Stephan Verosto, 2003, Evaluation of a Scale Prevention Device for the Masker and Prairie Air Coolers on USS THE Sullivans (DDG68), NSWCCD-63-TR-2002/3
- [5] Heat Transfer Coefficient from the Zhukauskas (1972) correlation for plain tube banks
- [6] Briggs P.E. and Young E. H. of (1963) correlation for individual circular fins
- [7] Webb “Principles of Heat Transfer 1994, Chapter 14”, the Zhukauskas correlation for finned tube

## **Appendix A**

### **FINAL REPORT - Design and Fabrication of a Prototype Full-Scale Heat Pipe Bleed Air Cooler Heat Exchanger**

## Final Report

# Design and Fabrication of a Prototype Full-Scale Heat Pipe Bleed Air Cooler Heat Exchanger

Contract No. N65540-03-C-0065



Prepared For: Naval Surface Warfare  
Center, Carderock Division  
5001 South Broad Street  
Philadelphia, PA 19112-1403

November 17, 2005



**Thermacore International, Inc.**  
A subsidiary of Modine Manufacturing Company

### **Program Summary**

The fabrication of the full-scale prototype heat pipe bleed air cooler heat exchanger (HP-BAC) was successfully completed. It was delivered to the Naval Surface Warfare Center, NSWC, in January of 2005. The delivery of the HP-BAC and this final report completes the Thermacore obligations on this contract. NSWC installed and tested the HP-BAC on the DDG-61 USS Ramage along side the presently used Shell & Tube-Bleed Air Cooler (S&T-BAC). The results of the NSWC testing are summarized in Appendix A.

The HP-BAC is designed to replace the existing shell and tube design. The shell and tube BAC design is subject to damage due to corrosion and fouling which leads to high maintenance costs to clean, repair or replace the unit. The HP-BAC design is expected to reduce damage due to corrosion and fouling thereby reducing maintenance costs and increasing reliability.

The key technology inside the HP-BAC is heat pipes. Heat pipes are high conductivity devices that transfer heat by the evaporation and condensation of a working fluid. There are 195 independent heat pipes inside the unit. Each heat pipe transfers heat isothermally from the hot air side to the seawater side. Since the heat pipes operate independent of each other, failure of one or more heat pipes, for whatever the reason, will have limited impact on the performance of the unit. The remaining heat pipes will help pick-up the lost thermal load. In addition, a failed heat pipe does not lead to a leak between the air and the seawater side. Conversely, the shell and tube BAC design is a single point failure.

Analysis indicates that the HP-BAC design is capable of meeting the thermal performance requirements for rejecting 416.7kW at the worst case operating condition of 925°F bleed air condition. The nominal operating condition is expected to be 700°F. Structural analysis was conducted on the HP-BAC design. This analysis guided the material thickness selections to meet the structural and pressure containment requirements. The prototype HP-BAC was pressure tested to confirm the results. Budgetary pricing for 10, 25 and 50 units is summarized in this report.

<b>Table of Contents</b>	<b>Page</b>
<b>Program Summary</b> .....	2
<b>1.0 Background Information</b> .....	4
<b>2.0 HP-BAC Design Requirements</b> .....	5
<b>3.0 HP-BAC Full-Scale Prototype Design</b> .....	7
<b>4.0 Structural Analysis Results</b> .....	11
<b>5.0 HP-BAC Thermal Performance Analysis Results</b> .....	11
<b>6.0 Projection of Production Costs</b> .....	14
<b>7.0 List of Tasks to Fabricate a Production, Full-scale HP-BAC</b> .....	15
<b>8.0 Conclusions and Recommendations:</b> .....	16
<b>Acknowledgements</b> .....	16
<b>References</b> .....	16
<b>Appendix A. NSWC Heat Pipe Cooler Technology Demonstration on the DDG-61 USS Ramage</b>	
<b>Appendix B. Ship Survey Report</b>	
<b>Appendix C. Heat Pipe Design and Development</b>	
<b>Appendix D. EWI Welding and Engineering Support Report</b>	
<b>Appendix E. Structural Design Report</b>	
<b>Appendix F. Thermal Analysis Models</b>	

<b>List of Figures</b>	<b>Page</b>
Figure 1. Heat Pipe Bleed Air Cooler, HP-BAC .....	7
Figure 2. Exploded View of HP BAC. ....	9
Figure 3. Front View of HP-BAC Showing Welded Baffles to Prevent Flow-Bypass. ....	9
Figure 4. Side View illustrating the Three Heat Pipe Sections.....	10
Figure 5. Heat Pipe Tube Sheet. ....	10

## 1.0 Background Information

Bleed air is extracted from the main propulsion and ship service turbines for use in a variety of functions including ASW Prairie/Masker systems and turbine start functions. Bleed air extracted from the turbine can be as hot as 925°F and must be cooled to as low as 190°F to perform these other functions. Bleed air coolers provide this temperature reduction using seawater as the heat sink.

Current bleed air coolers (BAC) use shell and tube heat exchangers (HX) in which hot bleed air is fed to the shell side and seawater is fed to the tube side. The high temperature air readily heats the seawater side of much of the tube surfaces to temperatures in excess of the 150°F temperature at which fouling occurs. This fouling precipitates dissolved solids in the seawater, which forms scaling (calcareous deposits) on the tube walls. Scaling reduces heat transfer capacity which directly affects air temperature and down stream applications. Scaling results in local temperatures which approach the inlet air temperatures; elevated temperatures accelerate corrosion and wear, leading to leakage and catastrophic failure. A NAVSEA study concluded that the cost of maintenance and repair of BACs and related component was approximately \$2.3 million per year based on 3M data from 1996 for gas-turbine powered ships. Further work by NSWC showed that the use of hazardous material usage and waste disposal contributed an additional \$3 million in annual system support costs. The high maintenance costs lead NSWC to look at an alternative heat exchanger design that uses heat pipes.

A heat pipe version of the BAC, eliminates the direct contact of hot air and seawater across a thin tube wall. Heat is transported from the airside to the seawater side through numerous heat pipes. Heat pipes use the evaporation and condensation of a working fluid to transport the heat. A unique feature of saturated two-phase heat transfer is its isothermal properties. The inside surfaces of the heat pipe are very nearly the same temperature. Despite more than 800°F difference in temperature between the hot air and the seawater sides, the calculated temperature difference inside the heat pipe is less than 2°F. The heat pipe operating temperature is determined by the relative heat transfer from the airside and the waterside. Since water is much better than air at transferring heat, the heat pipe temperature can be much closer to the water temperature. By directly manipulating the relative heat transfer surfaces (i.e. the relative number and size of the fins on the air and water sides of the heat pipe), the surface temperature of the waterside can be maintained below the fouling temperature. Reduced fouling will save on the BAC reliability and maintenance costs.

There were essentially three phases to the HP-BAC development:

**Phase 1:** The first phase addressed heat pipe and heat exchanger fabrication development issues to confirm that a heat pipe BAC was feasible. This work was performed under Contract No. N6540-00-M-0618.

**Phase 2:** The second phase identified the full-scale design for the HP-BAC under Contract No. N6540-00-M-0618 through a contract funding modification.

**Phase 3:** The third phase involved taking this design and fabricating a full-scale version of the HP-BAC (CN # N65540-03-C-0065). The heat pipe version was designed to fit into the space occupied by the conventional shell and tube BAC heat exchanger. To aide in installation and test, a ship survey was conducted by NSWCC. The results are documented in Appendix B. The survey was conducted to gain insight into testing the prototype HP-BAC on the ship and to understand crew concerns as they relate to this new HP-BAC design.

## 2.0 HP-BAC Design Requirements

The design requirements for the HP-BAC are listed in Table 1. These requirements formed the basis for the design of the prototype unit. In addition, Table 2 lists the materials to be used to fabricate the unit.

**Table 1. HP-BAC Design Requirements**

<b>PERFORMANCE DATA</b>	<b>BLEED AIR COOLER</b>	
<b>COOLER CHARACTERISTICS</b>	<b>AIR SIDE</b>	<b>WATER SIDE</b>
FLUID CIRCULATED	Air (2450 SCFM)	Seawater
FLOW RATE (LB/HR)	11,231	46,350
INLET TEMPERATURE (°F)	925	85
OUTLET TEMPERATURE (°F)	425	116.3
PRESSURE DROP (ALLOW/CALC) (PSI)	2.46/1.5	3.000/1.406
VELOCITY AT INLET FLANGE FACE (FT/SEC)	198.9	4.14
MAX INTERNAL VELOCITY (FT/SEC)	85 to 90	3.21
NUMBER OF PASSES	1	1
DESIGN PRESSURE (PSIG)	100	50
TEST PRESSURE (PSIG)	150	100
DESIGN TEMPERATURE (°F)	925	300
LOG MEAN TEMPERATURE DIFFERENTIAL (LMTD) (°F)	535.878	
HEAT TRANSFER RATE CLEAN (BTU/HR/SQ FT/°F)	19.2	
HEAT TRANSFER SURFACE AREA (SQ FT)	140.59	
HEAT EXCHANGE (BTU/HR) (APPROX)	1,423,800 (416.9kW)	
WEIGHT DRY/FULL OF WATER (LBS)	2043/2143	
MAX LENGTH OF COOLER	Not to exceed 7.5 feet vice	
MAX DIAMETER OF COOLER	Not to exceed 16 inches	
<b>HEAT PIPE CHARACTERISTICS</b>	<b>Thermosyphon (wickless) Heat Pipes</b>	
HEAT PIPE WORKING FLUID	Water	

MAX HEAT LOAD/HEAT PIPE (WATTS/PIPE)	2863
MAX WATER SIDE PIPE WALL TEMP (°F) WITH 925°F INLET AIR	172
MAX WATER SIDE PIPE WALL TEMP (°F) WITH 700°F INLET AIR	150
SINGLE PIPE THERMAL RESISTANCE (°C/WATT)	0.06

**Table 2. HP-BAC Materials**

Item	Parts	Materials	Specification
1	Shell and Shell Side Baffles	Copper-nickel alloy, composition 70-30	MIL-T15005 or MIL-T22214
2	Stay Bolts	Stainless steel (AISI grade 347)	ASTM A 240 or ASTM A 473 or ASTM F 593
3	Water-Boxes	Copper alloy C90300 or valve bronze, alloy C92200; or copper-nickel alloy, composition 70-30	ASTM B 584 or ASTM B 61 MIL-C-15726
4	Heat pipe support sheets/tube sheet	Copper-nickel alloy, composition 70-30	MIL-C-15726
5	Tube sheet bushing	Copper-nickel alloy, composition 70-30	MIL-C-15726
6	Heat pipes	Copper-nickel alloy, composition 70-30	MIL-T-16420K
7	Fins air & water side	Copper-nickel alloy, composition 90-10	MIL-C-15726
8	Threaded Fastners	Nickel alloy	MIL-S-1222
9	Zinc protectors	Zinc	MIL-A-19521
10	Plugs, zinc support	Copper-nickel alloy, composition 70-30	MIL_C-15726
11	Gaskets	Rubber sheet, cloth insert; or non-asbestos sheet, compresses	HH-P-151 HH-P-46 MIL-G-24696



12	Pipe plus and adapters	Valve bronze, alloy C92200, copper alloy C90300; or copper-nickel alloy, composition 70-30	ASTM B 505 MIL-C-15726 Or MIL-C-24679
13	Zinc inspection covers	Copper-nickel alloy, composition 90-10, copper alloy C90300; or valve bronze, alloy C92200	MIL-C-15726 AST B 584 or ASTM B 61

### 3.0 HP-BAC Full-Scale Prototype Design

Figure 1 is a photograph of the completed prototype HP-BAC unit. A complete set of drawings for this unit is included as Appendix C of this report. Figure 2 is an exploded view of the prototype unit. There are essentially three component assemblies: Airside Shell, Heat Pipe Tube Sheet and the Seawater Shell. Each component is briefly described below.



**Figure 1. Heat Pipe Bleed Air Cooler, HP-BAC**

#### 3.1 Air-Side Shell

This shell is constructed from stainless steel. Figure 3 shows the internal construction. To help reduce flow bypass the sides of the cylindrical shell were “squared-off” to match the rectangular shape of the heat pipe core. As you can see, in Figure 3, there is quite a lot of unused volume within this HP BAC design.

### 3.2 Heat Pipe Tube Sheet

The tube sheet is 1.5” thick 70/30 copper/nickel. There are 195 copper-nickel thermosyphon (wickless) heat pipes welded into the tube sheet. The heat pipes are 0.836” in diameter and 8.720” long. Water is the internal working fluid. Table 3 is a summary of the heat pipe design. The heat pipe development effort is recorded in Appendix D. The tube sheet is divided in three heat pipe zones as shown in Figure 4. The fin pitches on the heat pipes were varied to evenly distribute the thermal loads. The fins on both the seawater side and airsides were brazed to the heat pipes. The completed heat pipe tube sheet is shown in Figure 5. There was considerable amount of welding development that went into getting the heat pipes installed into the tube sheet. This welding development was funded under a separate contract from NSWC to EWI. The results of this work are documented in Reference 1. A copy of the report is included as Appendix E.

**Table 3. Heat Pipe Thermosyphon Design Summary**

<b>THERMOSYPHONS (See Appendix B for Drawing Details)</b>		
Pipe Material/Class	70/30 Cu-Ni/3300	
OD (in)	0.836 +.000/- .005	
ID (in)	0.596 (STOCK)	
Length, Minus Fill Tube (in)	8.720	
Number of Heat Pipes	195	
Single-pipe Thermal Resistance (°C/W)	0.060	
<b>FINS (See Appendix B for Drawing Details)</b>		
	<b>Air Side</b>	<b>Seawater Side</b>
Material	90/10 Cu/Ni	
Geometry	Hexagon, 1.723 in	Circular, 1.220in OD
Thickness (in)	0.063 (STOCK)	
Thermal Conductivity (W/m-K)	43.9	
First Module (inlet) Fin Density (1/in)	2	3
Second Module (Middle) Fin Density (1/in)	3	3
Third Module (Outlet) Fin Density	5	3

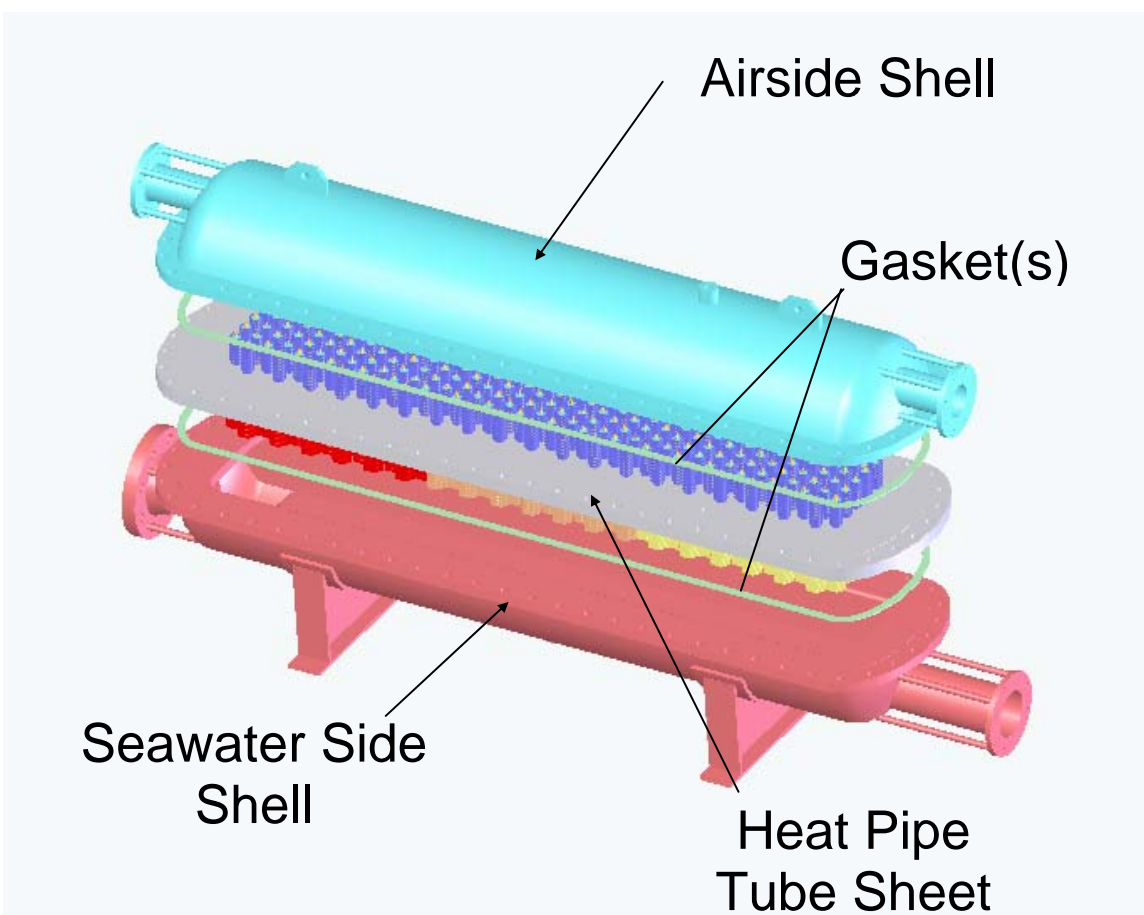


Figure 2. Exploded View of HP-BAC.

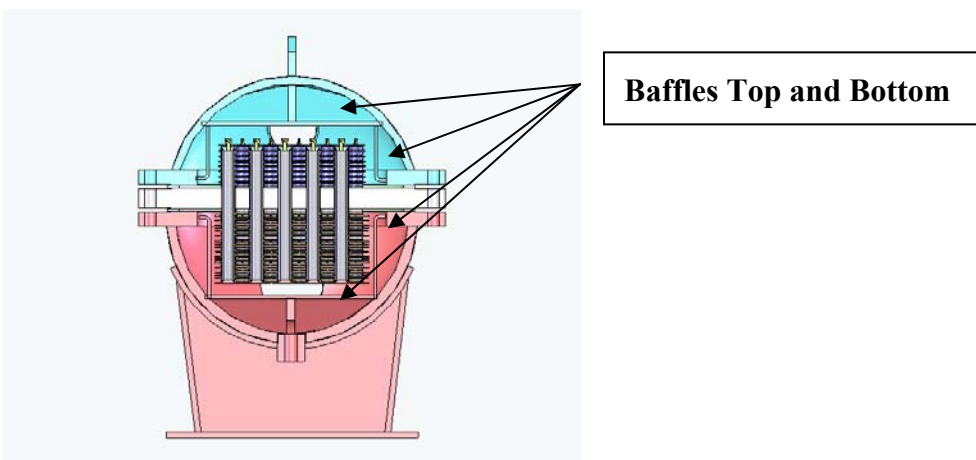
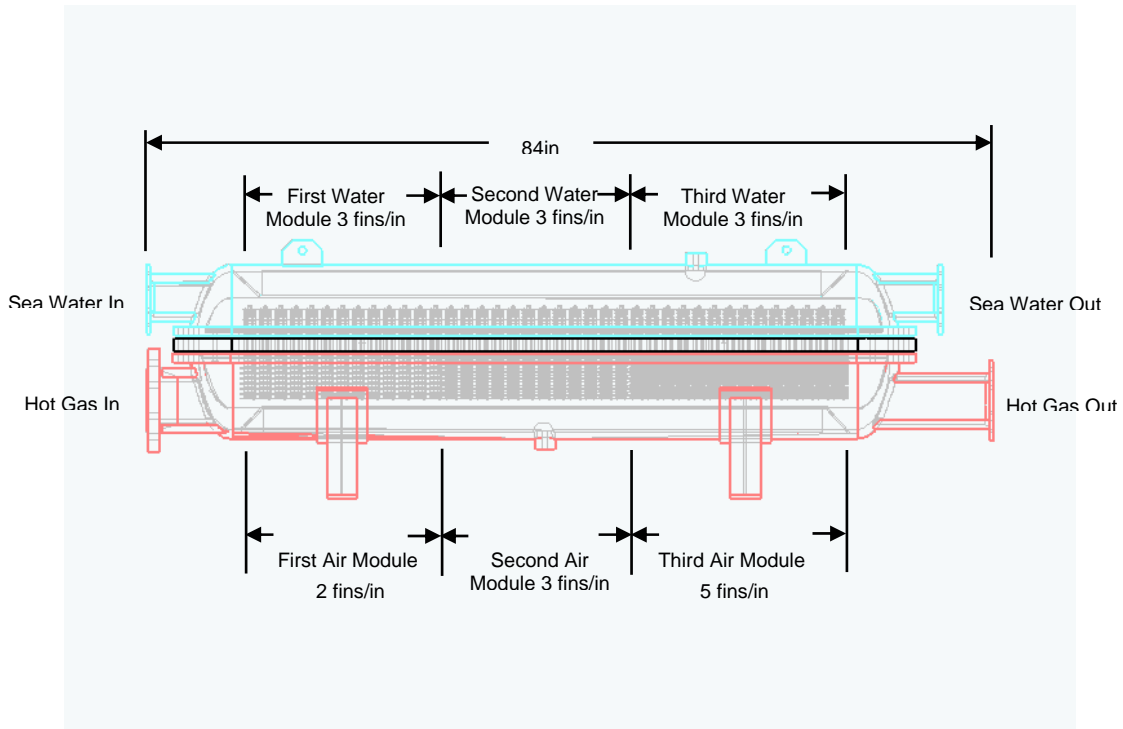


Figure 3. Front View of HP-BAC Showing Welded Baffles to Help Prevent Flow-Bypass.



**Figure 4. Side View illustrating the Three Heat Pipe Sections.**



**Figure 5. Heat Pipe Tube Sheet.**

Thermal performance analysis was conducted to derive the fin count listed in Table 3. However, it was based on a tube sheet thickness of 1.25". The structural analysis indicated that the heat pipe tube sheet needed to be 1.5" thick. However, to maintain schedule, a decision was made prior to this structural analysis being completed on how long to make the heat pipes. With using the real tube sheet thickness of 1.5", it makes the heat pipes 0.25" shorter than desired, consequently, not all the fins could be applied. The heat pipe length will need to be corrected in future efforts. The reduced heat pipe length and fin count will have an impact on thermal performance of the HP-BAC. This impact is accessed in Section 5.0. The actual fin count on the "as built" prototype is summarized below.

**Airside**

<b>Air fins</b>	<b>Specified</b>	<b>Actual</b>
Module 1	9 per pipe	8 per pipe (4 pipes only have 7 per pipe for Thermocouple installation)
Module 2	14 per pipe	12 per pipe (2 pipes only have 11 per pipe)
Module 3	23 per pipe	19 per pipe (2 pipes only have 18 per pipe)
Total air fins:	2,990	2,529 fins(difference of 461)

**Water Side**

<b>Water Fins</b>	<b>Specified</b>	<b>Actual</b>
All modules	8 per pipe	7 per pipe (2 pipes only have 6 per pipe)
Total water fins:	1,560	1,359 fins (difference of 201)

**3.3 Water Side Shell**

This shell is constructed from 70/30 copper nickel alloy. To reduce flow bypass the sides of the cylindrical shell were “squared-off” to match the rectangular shape of the heat pipe core.

**3.4 Gasket and Bolts**

Two large gaskets that are 1/8”thick by 3/4” wide Garlock-Type 601 Corragraph-Monel core with graphite facing make the seal between the heat pipe tube sheet and the airside shell and the waterside shell. The bolts are (62) 5/8”-11 UNC by 5.25” long Monel per QQ-N-281(a).

**4.0 Structural Analysis Results**

SC Solutions, Sunnyvale, CA, conducted a structural analysis of the HP-BAC. The results of the analysis are documented in their report contained in Appendix F and cited as Reference 2. Their report indicates that the prototype design for the bleed air cooler will remain within ASME Section VIII limits for strength. The drawings for the HP-BAC were developed based on the results of this analysis.

**5.0 HP-BAC Thermal Performance Analysis Results**

A Math-Cad model of the heat exchanger was written to predict thermal performance. This model is included in Appendix G. This model was developed based on the following:

- This predictive model is 1-D and as such, it is not able to fully capture flow bypass effects when the gaps around the cores are large. It is possible that a significant amount of fluid on both sides of the exchanger will bypass the finned cores in the “as-built” condition.

- The model assumes perfect thermal contact between fins and thermosyphons. In reality, there is some thermal resistance at the intervening braze joints. In addition, the EWI welding report in Appendix D points to incomplete braze fillets at the fin to heat pipe joint of the prototype unit. This will have an impact on the measured results and will need to be corrected on the future production units.

There were two inlet airside temperature conditions analyzed: 700°F and 925°F. The 700°F condition is the normal operating temperature condition and the 925°F represents the worst-case high temperature operating condition. In addition to these temperatures, the HP-BAC thermal performance was predicted for both the clean and the fouled conditions at these temperatures. The results are summarized in Table 4. The HP-BAC will meet the requirement of rejecting 416kW at the 925°F un-fouled condition. The maximum predicted heat pipe temperatures on the seawater side at the 700°F and 925°F bleed air conditions are 155.5°F and 183.6°F, respectively. These temperatures are slightly higher than the desired temperatures listed in Table 1.

As presented in this report, the prototype unit was not constructed as specified due to some issues that arose during the fabrication of the prototype. This is to be expected when fabricating an item like this for the first time. The predicted results for the “as built” prototype are summarized in Table 5.

At the 700°F condition, the “as built” unit is expected to reject 242.1kW in the clean condition and 230.4kW in the fouled condition. At the 925°F condition, the unit is expected to reject 336.6kW in the clean condition and 320.3kW in the fouled condition. This performance is 80.3kW (clean) and 96.6kW (fouled) below the requirement (see Table 1). The cause for the reduced performance is due to:

- Flow bypass around the heat pipe fin pack. The large flow bypass was an artifact of the fabrication process. Wiegmann and Rose felt they needed additional space to avoid hitting and bending the heat pipe fins during assembly of the HP-BAC unit. The thermal performance of the unit can be restored if these large gaps are eliminated. This will need to be addressed in the future production phase of this program.
- Reduction in the fin count. This is easily solved by using the specified heat pipe length so that all the fins can be added to the heat pipes.

These performance reduction issues will be corrected in the production phase.

**Table 4. HP-BAC Predicted Performance.**

Rev: 28 May 2004		
SHELL AND TUBE SHEET (See Appendix B for Drawing Details)		
	AIR SIDE	SEA WATER SIDE
Baffle Separation, Width (in)	10.25	
Baffle Height Above Tube Sheet Surface (in)	5.375	3.813
MASS FLOW RATES		
Air Side Flow (lbs/hr)	11230	
Sea Water Side Flow (gpm)	134	
THERMAL AND HYDRODYNAMIC PERFORMANCE		
Total Heat Transfer Surface Area (ft <sup>2</sup> )	107.6	
	CLEAN	FOULED
Inlet Air Temp. (deg-F)	700	
Outlet Air Temp. (deg-F)	403	417.6
Inlet Sea Water Temp. (deg-F)	85	
Outlet Sea Water Temp. (deg-F)	96.7	96.1
Heat Load (kW)	242.1	230.4
Log Mean Temp. Differential (LMTD, deg-F)	443.2	452.7
Overall U value (BTU/hr/ft <sup>2</sup> /deg-F)	17.33	16.14
Max Thermosyphon Heat Load (Watts)	1453	1366
Air Side Fouling Factor (deg-F-hr-ft <sup>2</sup> /BTU)	0	0.00025
Sea Water Side Fouling Factor (deg-F-hr-ft <sup>2</sup> /BTU)	0	0.0005
Max Water-Side Pipe Wall Temperature (deg-F)	155.5	182.7
Air Side Pressure Differential (psid)	1.3	1.3
Sea Water Side Pressure Differential (psid)	0.97	0.97
	CLEAN	FOULED
Inlet Air Temp. (deg-F)	925	
Outlet Air Temp. (deg-F)	519.5	539.5
Inlet Sea Water Temp. (deg-F)	85	
Outlet Sea Water Temp. (deg-F)	101.6	100.8
Heat Load (kW)	336.6	320.3
Log Mean Temp. Differential (LMTD, deg-F)	604.8	618
Overall U value (BTU/hr/ft <sup>2</sup> /deg-F)	17.65	16.44
Max Thermosyphon Heat Load (Watts)	2031	1907
Air Side Fouling Factor (deg-F-hr-ft <sup>2</sup> /BTU)	0	0.00025
Sea Water Side Fouling Factor (deg-F-hr-ft <sup>2</sup> /BTU)	0	0.0005
Max Water-Side Pipe Wall Temperature (deg-F)	183.6	221.4
Air Side Pressure Differential (psid)	1.52	1.52
Sea Water Side Pressure Differential (psid)	0.97	0.97

**Table 5. “As Built” HP-BAC Predicted Performance.**

Rev: 28 May 2004		
SHELL AND TUBE SHEET (See Appendix B for Drawing Details)		
	AIR SIDE	SEA WATER SIDE
Baffle Separation, Width (in)	10.25	
Baffle Height Above Tube Sheet Surface (in)	5.375	3.813
MASS FLOW RATES		
Air Side Flow (lbs/hr)	11230	
Sea Water Side Flow (gpm)	134	
THERMAL AND HYDRODYNAMIC PERFORMANCE		
Total Heat Transfer Surface Area (ft <sup>2</sup> )	107.6	
	CLEAN	FOULED
Inlet Air Temp. (deg-F)	700	
Outlet Air Temp. (deg-F)	403	417.6
Inlet Sea Water Temp. (deg-F)	85	
Outlet Sea Water Temp. (deg-F)	96.7	96.1
Heat Load (kW)	242.1	230.4
Log Mean Temp. Differential (LMTD, deg-F)	443.2	452.7
Overall U value (BTU/hr/ft <sup>2</sup> /deg-F)	17.33	16.14
Max Thermosyphon Heat Load (Watts)	1453	1366
Air Side Fouling Factor (deg-F-hr-ft <sup>2</sup> /BTU)	0	0.00025
Sea Water Side Fouling Factor (deg-F-hr-ft <sup>2</sup> /BTU)	0	0.0005
Max Water-Side Pipe Wall Temperature (deg-F)	155.5	182.7
Air Side Pressure Differential (psid)	1.3	1.3
Sea Water Side Pressure Differential (psid)	0.97	0.97
	CLEAN	FOULED
Inlet Air Temp. (deg-F)	925	
Outlet Air Temp. (deg-F)	519.5	539.5
Inlet Sea Water Temp. (deg-F)	85	
Outlet Sea Water Temp. (deg-F)	101.6	100.8
Heat Load (kW)	336.6	320.3
Log Mean Temp. Differential (LMTD, deg-F)	604.8	618
Overall U value (BTU/hr/ft <sup>2</sup> /deg-F)	17.65	16.44
Max Thermosyphon Heat Load (Watts)	2031	1907
Air Side Fouling Factor (deg-F-hr-ft <sup>2</sup> /BTU)	0	0.00025
Sea Water Side Fouling Factor (deg-F-hr-ft <sup>2</sup> /BTU)	0	0.0005
Max Water-Side Pipe Wall Temperature (deg-F)	183.6	221.4
Air Side Pressure Differential (psid)	1.52	1.52
Sea Water Side Pressure Differential (psid)	0.97	0.97

## 6.0 Projection of Production Costs

The HP-BAC production cost projection shown in Table 6 was based on the following:

- Thermacore is the prime contractor responsible for managing the construction of the HP-BAC production units.



- There is a Non-Recurring Engineering, NRE, charge to complete the tasks defined in Section 7.0.
- A local vendor will machine the tube sheet.
- Thermacore will be responsible for fabricating and welding the heat pipes into the tube sheet.
- Thermacore will be installing the airside and waterside fins with braze material at the interface. The assembly will then be vacuum brazed at a local furnace vendor.
- A subcontractor (Wiegmann and Rose for example) will construct the airside shell and the waterside shell.
- Each unit is hydrostatically tested to at 1 ½ times the design pressure and certified.
- A unit needs to be shock and vibration tested. The price for conducting this test is unknown at this time.
- Thermacore will assemble the units and ship them to the Navy.

**Table 6. HP-BAC Projected Production Costs.**

Description	Cost		
	10 Units/year	25 Units/year	50 Units/year
Production (ROM)	\$197,296 ea.	\$196,032 ea.	\$194,722 ea.
Tooling Required	\$24,000	\$24,000	\$24,000

### 7.0 List of Tasks to Fabricate a Production, Full-scale HP-BAC

Below is a list of tasks leading up to release of a production order.

**Task 1 Analysis of HP-BAC Cost Reducing Items:** This report identified several areas to examine for cost reductions. This task will evaluate those areas to determine if they should be implemented into the design.

**Task 2 Update Drawings:** Based on the results of Task 1, the drawings will be updated, reviewed and approved.

**Task 3 Heat Pipe Fin Attachment Development:** Fin attachment on the prototype unit was identified as a problem area. This task will work on the methods to demonstrate an affective process or fin attachment.

**Task 4 Fabricate Pre-Production HP-BAC Unit:** An initial production HP-BAC unit will be fabricated in accordance to the results of Tasks 2 and 3.

**Task 5 Shock and Vibration Test:** The HP-BAC unit fabricated in Task 4 will be shock and vibration tested to qualify the design.

**Task 6 Confirm Thermal Performance:** The initial production unit will be thermal performance tested to confirm that the design meets the required performance.

## **8.0 Conclusions and Recommendations:**

1. The design and fabrication of the full-scale prototype heat pipe bleed air cooler heat exchanger (HP-BAC) was successfully completed. It was delivered to the Naval Surface Warfare Center, NSWC, in January of 2005.
2. The predicted thermal performance of the “as-built” HP-BAC is lower than desired. This is due to both large gaps around the perimeter of the heat pipe bundles that will result in flow bypass around the heat pipes and to reduced fins. Fortunately, if these large gaps are reduced and fins are added in future units, the performance of the unit can be restored.
3. The air and seawater sides of the prototype unit were hydrostatically tested to 1-1/2 times the design pressure and shown to pass the listed criterion.
4. EWI identified that the brazed fins on the waterside of the exchanger need further development. Many of the braze joints did not have good thermal connection to the heat pipe. It is recommended that this be further developed in the production unit fabrication effort.
5. The heat pipe length was shorter than desired. The heat pipe length will need to be increased in future efforts.
6. An important design feature for the HP-BAC is the three distinct heat pipe sections. Since the air-cools as it passes through the heat exchanger, there is a much larger delta-T available at the inlet than out the outlet. In the absence of design mitigation, this would produce much higher surface temperatures in this region. One of the earliest design innovations, one that was made possible by the use of heat pipes in the heat exchanger, was to reduce the fin area in the high temperature parts of the HX and increase the fin area in the lower temperature regions. This allows relatively constant temperature over the length of the BAC; it also keeps the power per heat pipe relatively constant over the entire length.

## **Acknowledgements**

This program was funded through the Naval Surface Warfare Center in Caderock Division in Philadelphia, PA. Mr. Denis Colahan served as the technical monitor for the program. His help and support throughout the program was greatly appreciated. Thermacore would also like to acknowledge Wiegmann and Rose, Oakland, CA, for their fabrication of the airside and seawater sides of the shells. In addition, Advanced Thermal Technologies, Lancaster, PA, served as a subcontractor for fabrication of the heat pipe tube sheet.

## **References**

1. Conrardy, et al., Welding Engineering Support for Advanced High Temperature Heat Pipe Heat Exchanger Prototype Fabrication, Navy ManTech Program Project No. R0644, Contract no. N00014-02-C-0106, April 1, 2005.

2. Boyak, Craig, Structural Design Report for Prototype of 425 kW Mono-Height Heat Pipe Hot Gas to Water Heat Exchanger Bleed Air Cooler, SC Solutions, Sunnyvale, CA, May 17, 2004.

## **Appendix A-A**

### **NSWC Heat Pipe Cooler Technology Demonstration on the DDG-61 USS Ramage**

.....

”  
”

## **NSWC Heat Pipe Cooler Technology Demonstration on the DDG-61 USS Ramage**

Status / update on PP-0302 Elimination of Acid Cleaning of High  
Temperature Salt Water Heat Exchangers

### **“Heat pipe cooler technology demonstration On the DDG-61 USS RAMAGE”**

#### **Background:**

As you know, a full-scale Heat Pipe-Bleed Air Cooler (HP-BAC) was constructed and testing began on the DDG-61 USS Ramage along side the presently used Shell & Tube –Bleed Air Cooler (S&T-BAC). The bleed air system on a DDG-51 class ship has a total of 5 shell & tube coolers; 2 in Main Engine Room No.1 (MER-1) (1 prairie and 1 masker); 2 in MER-2 (1 prairie and 1 masker); and 1 in Auxiliary Room No.1 (AUX-1)(1 start air). The demonstration HP-BAC was installed into the masker cooler location in MER-1. This Temporary Alteration (TEMPALT) replaced the masker shell and tube cooler along with some system piping, foundation changes, and added an automated instrumentation package. Since the normal operation procedure is to operate both masker coolers in parallel the test plan was to do a comparison between the masker HP-BAC in MER-1 and the masker S&T-BAC in MER-2. A detailed test plan was developed for this comparison.

The installation of the TEMPALT started on 2 June 2005 and was completed on 22 June 2005 onboard the DDG-61 USS Ramage. Over all the installation went quite well. Since the ship had just come out of a CNO availability quite a bit of activity was still on going during this short in port time after availability. As a result of this we never had the opportunity to due a pier side test. A few days later the ship left port spent some time in Maine and returned back to port in early July. During this short deployment the automated data acquisition system recorded temperatures and flow data for the HP-BAC. A similar system recorded temperature only data on the S&T-BAC. The ship also recorded manual data hourly from the thermal well temperature gages. Some additional gages were installed for this demonstration. The ships log data and system operational information was relayed back to NSWC via email while the ship was deployed. Early indications from the ships log data were that the HP-BAC was not meeting the same outlet temperatures as the counter part S&T-BAC. Ship data showed a difference between the two cooler to be approx. 200 °F. This was confirmed from the automated system that was down loaded once the ship returned to port.

First thoughts for this temperature difference were focused on the gap areas that were left between the heat pipe tube sheet at the top, bottom and sides between the tube sheet bundle and shell sections. Pictures in Appendix A shows these gaps quite well. These gaps were identified prior to the install and again during the install. It was felt that these might give us some high discharge temperatures. However it was decided to leave the cooler go in, as design, to see what the actual flow and temperature performance data would be. In early July after discussion with the ship and port engineer it was decide to install baffle plates onto the air and water shell sections of the cooler to address the blow-by. During the period of 7-22-05 to 7-27-05 baffle plates were installed, see pictures in

Appendix A for completed install and baffle modification. Once the install was complete a short operation test, while pier side, was done on the modified HP-BAC to see how it would perform. Only the masker coolers were run, which discharged air into the masker belts under the hull. This pier side operational test was only conducted for approximately one hour. The temperatures were starting to approach steady state and some improvement was noticed. In comparing the two data sets it did show a 40 °F. NSWC is currently awaiting additional at sea data to document and compare the HP-BAC flow performance data with baffle plates installed and running at steady states.

## Review of the Data

Table 1 compares the measured data from the HP-BAC to the S&T-BAC. The key parameter to compare is the resulting inlet and outlet air temperature difference (highlighted in yellow). The larger this difference, the better the cooler is working. For example, the 6/24/05 data indicates that the airside difference for the S&T-BAC is 430.65 °F and the HP-BAC is 165.24 °F, a difference of 264.41 °F. This is a significant difference.

**Table 1. Measured Test Data.**

Date and Time	M30277 MER-1 TC-2 AIR-IN (°F)	M30277 MER-1 TC-4 AIR-OUT (°F)	Δ T MER-1 air	M30322 MER-2 TC-2 AIR-IN (°F)	M30322 MER-2 TC-4 AIR-OUT (°F)	Δ T MER-2 air	M3027 7 MER-1 TC-1 SW-IN (°F)	M30277 MER-1 TC-3 SW-OUT (°F)	M30322 MER-2 TC-1 SW-IN (°F)	M30322 MER-2 TC-3 SW-OUT (°F)	M30742 MER-1 Air Flow (SCFM)
6/24/2005	554.59	389.35	165.24	568.85	138.20	430.65	70.47	75.02	70.21	77.83	1707
6:00 AM											
6/29/2005	541.58	362.25	179.33	560.66	139.86	420.80	70.95	74.16	70.72	80.67	1287
3:30 AM											
6/29/2005	544.66	364.87	179.78	564.37	140.67	423.70	70.70	73.99	70.48	80.67	1309
12:45 AM											
<b>7-22-05 to 7-27-05 Baffle Plates installed onto the shell sections of both the air and water</b>											
7/27/2005	543.79	322.99	220.81	511.34	141.76	369.58	84.34	89.92	83.91	85.93	1749
2:00 PM											

Dr. Kevin Wert from Thermacore ran the performance model to determine if the HP-BAC is performing as expected. The measured and predicted results are compared in Table 2.

**Table 2. Comparison of Measured versus Predicted for MER-1.**

	Date and Time	M30277 MER-1 TC-2 AIR-IN (°F)	M30277 MER-1 TC-4 AIR- OUT (°F)	Δ T MER-1 air	M30277 MER-1 TC-1 SW-IN (°F)	M30277 MER-1 TC-3 SW- OUT (°F)	Δ T MER-1 SW	M30742 MER-1 Air Flow (SCFM)
Measured	6/24/2005	554.59	389.35	165.24	70.47	75.02	4.55	1707
Predicted		554.59	275.2	279.39	70.47	77.7	7.00	1707
Measured	6/29/2005	541.58	362.25	179.33	70.95	74.16	3.20	1287
Predicted		541.5	236.39	305.11	70.95	76.41	5.71	1287
Measured	6/29/2005	544.66	364.87	179.78	70.70	73.99	3.29	1309
Predicted		544.66	239.27	305.39	70.70	76.29	5.59	1309
	Baffle Plates Installed							
Measured	7/27/2005	543.79	322.99	220.81	84.34	89.92	5.58	1749
Predicted		543.79	279.72	264.07	84.34	90.80	6.46	1749

Again, the key parameter to compare is the airside temperature difference. The predicted temperature difference for the 6/24/05 data is significantly higher (114 °F) than the measured results. This is true for the other data sets too. The lack of HP-BAC measured performance is linked to all of the following issues.

- **Fin Attachment**
- **Fins per Inch**
- **Heat Pipe Operation**
  - Thermal resistance
  - Active pipes
  - Length of pipes
  -

These technical issues will be discussed in further detail in the technical review section. At this point one would have to ask some obvious questions.

- Were do we go from here?
- Why are we off on the cooling performance?

### **Decision Based on Above Data**

**Were do we go from here?**

Originally it was discussed to due another modification that would address further improvements. However, after a technical review it was felt that another modification would not make up for this kind of difference. Over the pass few weeks' discussions and meetings were held, between NSWC, Thermacore, and Wiegmann & Rose to address the cooler performance and solutions. Again, more on this in the technical review section.

In the interim of solving the coolers technical problems it was decided to reconfigure the ship with its original shell and tube cooler. Plans are under way to pull the masker HP-BAC in MER-1 and to reinstall the masker S&T-BAC. This reinstall won't be an exact reconfiguration. The structural foundation, which was extended onto the original foundation, will remain in place. This will be done to allow for the reinstallation of the HP-BAC in approx 12 to 18 months after a redesign and some modifications are completed. As was done with the original inlet and outlet spool pieces of the S&T-BAC, the HP-BAC will be removed in whole and stored. Other things that will be left in place are the temperature and flow data loggers, which measure in and out temperatures on both the coolers and the flow meter. Discussion and approvals are taking place that will leave the mass flow meter in place, in MER-1. This will be beneficial to better understanding the flow characteristics and heat loads of the masker cooler during deployments. This flow data was never available during the heat pipe cooler development. Plans for the changing back to the ships original reconfiguration will be the week of November 14<sup>th</sup> during the ship's CMAV period. Tentative reinstall date for heat pipe redesign cooler is June 2006. The reinstall of the HP-BAC back into the ship will be based on a successful coupon check before the new full-scale tube sheet is fabricated. See Task to Accomplish a Redesign

### **Technical Review Issues with HP-BAC:**

- **Heat Pipe Operation:** The heat pipe cooler model was run with some recently recorded data. Which accounts for some shortcomings due to of blow-by and missing fins, this model still indicates the cooler should be performing at approximately 275 °F vice the 365 °F outlet temperatures. Which indicates that there are issues with the heat pipes. The target thermal resistance for the heat pipes established at the start of the program was 0.06°C/W. NSWC instrumented eight heat pipes during the shipboard testing. This data was used to determine the actual heat pipe thermal resistance. This values listed in Table 3 indicate that the average heat pipe thermal resistance is about 0.205 C/W, 3.41 times higher then desired. This significantly adds to reduced HP-BAC performance. Which raises some other questions. Are all the heat pipes working? and What are the thermal resistances of the other 187 pipes? Of the 195 pipes only 8 are being monitored (4 in module 1, 2 in module 2, 2 in module), see Appendix A for additional details on the instrumentation of the tube sheet. Once the cooler is pull and returned to NSWC test will be performed on each pipe to determine its status as well as a plan to determine the resistance of all the pipes.



**Table 3. Measured Heat Pipe Thermal Resistance, °C/W**

Date/ Time	Row1/ #2	Row1/ #4	Row13/ #2	Row13/ #4	Row26/ #2	Row26/ #4	Row39/ #2	Row39/ #4	Average
6/24/05	0.253	0.223	0.234	0.215	0.17	0.156	0.124	0.135	0.189
6/29/05	0.309	0.259	0.267	0.242	0.182	0.171	0.131	0.144	0.213
6/29/05	0.306	0.254	0.264	0.240	0.181	0.17	0.132	0.144	0.212
7/27/05	*	*	*	*	*	*	*	*	<b>0.205</b>

\* Thermacore did not have heat pipe temperature data on this test.

- **Fin Attachment:** Issues were raised concerning fin attachment to the heat pipes. More development work in this area needs to be done in order to improve the fin attachment method. During the fabrication Edison Welding Institute (EWI), under the MANTECH program, participated in addressing some of the joining issues. The joining of the fins to the pipe required a large furnace braze. A coupon of pipes with fins was made for analysis by EWI. The EWI report showed the metallographic work, which was done on these pieces, see Figure 1 and Figure 2. The results indicate the brazed fin-to-tube assemblies have moderate braze quality. Voids were found in all five of the examined assemblies. During the fabrication it was not felt that this would be that significant to the performance. In hind site this thought may not have been a valid one. These small voids in the braze joins could be adding significantly to the thermal resistance of the heat pipes. Because of this EWI report and the time involved to attach these fins a proposal was prepared to further investigate with the in FY-06 MANTECH program casting assemblies as well as better joining. It was hoped that this effort could be integrated into the production effort as it turns out it should be beneficial in a redesign effort if funded in FY-06
- **Fins per Inch:** Due to fabrication issues, there were several less fins then desired. It is possible that increasing the fins per inch on the airside is desired. Unfortunately, there are no airside pressure drop values measured during the shipboard testing to provide design guidance in this area. The addition of Delta P readings will be addressed in the redesign.
  - As indicated above there are 662 fins (461air, 201 water) missing, see Table-4 for detail breakout, this was a result of:
    - The tube sheet going from 1" to 1¾.
    - The heat pipe lengths were established before the change was made to add the thicker tube sheet thickness based on W&R structural analysis.
    - The silver braze rings, which were inserted on top of each fin added to gaps between the fins. This small growth became most significant in the 5 fins per inch module of the air side.
    - Attempts were made to use a tapered plug for the heat pipe processing. However, this process did not achieve good result as a

result the heat pipes used the standard fill pipe for processing which shortened the pipe length

<b>Table 4 - Tube sheet fin count CAD vs. Actual</b>		
<b>Air fins</b>	<b>CAD Sheet</b>	<b>Actual</b>
Module 1	9 per pipe	8 per pipe (2 pipe only have 7 per pipe)
Module 2	14 per pipe	12 per pipe (2 pipe only have 11 per pipe)
Module 3	23 per pipe	19 per pipe (2 pipe only have 18 per pipe)
<b>Total air fins:</b> <b>(difference of 461)</b>	<b>2990</b>	<b>2529 fins</b>
<b>Water Fins</b>	<b>CAD Sheet</b>	<b>Actual</b>
Modules 1,2,3	8 per pipe	7 per pipe (2 pipe only have 6 per pipe)
<b>Total water fins: 1560</b>	<b>1359 fins</b>	<b>(difference of 201)</b>
<p><b>Note:</b> this is a reduction of 15 % in the fin stacking due to pipe length change caused by going from a 1" tube sheet to a 1 3/8" tube sheet. Additionally, the lengths of the basic pipes was established first (8.359") and fabricated. Pipe length compensation was not made up with this change in tube sheet thickness.</p>		

- Flow Patterns through the Cooler:** Even though some baffle plates were installed the air still converges and diverges into the gap area as it goes through the modules. It's felt that more cross flowing through the modules should be taking place and all gaps need to be addressed and eliminated. NSWC installed four baffle plates and showed approximately 40 °F improvement in the airside temperature difference. The best solution, however, is to seal against the entire heat pipe bundle.
- Hind Site With the Fabrication:** During development it was thought that to demonstrate the technology it would be more cost effective to stay with a mono height pipe to demonstrate the abilities of the technology to control wall temperatures and scaling on the pipes. This decision was true! However in doing so we sacrificed a fair amount of surface area. The cooler was design with this in mind and should be meeting the model criteria, which was re-run for blow by and missing fins. The benefit to be achieved later was that this unused surface area would benefit the size reduction of the cooler once it went to a production phase. See Figure 3 for a comparison of mono to multi height pipes. In hind site the cost impact would not have been that significant to manufacturing. In doing a redesign a small coupon will first address the multi height pipes. A successful small coupon fabrication and test will be followed by a final full-scale tube sheet

fabrication that will also incorporate these multi height pipes. This will achieve a few things, one it will maximize the heat transfer surface area for cooling, this maximizing may still help in reducing the production size coolers, validate the more complex modeling geometries, and better identify the heat transfer abilities as we move closer to a production unit.

- Operation Conditions:** It is important to note that the HP-BAC was designed to be able to operate at 925 °F and to not have the heat pipe wall temperature on the seawater side exceed 150 °F, in an attempt to minimize calcareous deposits. This design condition resulted in building thermal resistance into this cooler, which resulted in a much larger and heavier cooler when compared to the current BAC. In addition, this “built-in” thermal resistance resulted in what appears to be lower performance of the HP-BAC when they are compared.

Information identified in Figure 4 indicates the cooler rarely operates, if at all, at this high temperature condition. In fact, the cooler operates 99% of the time at temperatures below 700 °F. In general, optimizing a design for operation at 925 °F and 700 °F conditions, and then testing it at much lower temperature, results in performance that is unfavorable for the HP-BAC when compared to the standard S&T-BAC. Thermacore believes that the performance of the HP-BAC can be significantly improved if the design point is lowered to 700 °F and normal operation temperatures of 550 °F to 650 °F are addressed in detail.

Thermacore analysis indicates the performance of the HP-BAC can be significantly improved if the flow bypass is significantly reduced, if the fin attachment is improved, if the fins per inch are increased and if the heat pipe thermal resistance is reduced. Under these conditions, the predicted thermal performance is shown in Table 5. For comparison purposes, the predicted HP-BAC performance is compared to the data for the S&T-BAC (MER-2) unit. The results show that the HP-BAC can reach performance close to the BAC; however, it will never meet the performance of the S&T-BAC because there is still “built in” thermal resistance into the HP-BAC design in order to keep the seawater side temperature under 150 °F to minimize/eliminate calcareous deposits.

**Table 5. Projected HP BAC Performance in comparison to Shell-and Tube Unit**

	AIR-IN (°F)	AIR-OUT (°F)	Δ T air	SW-IN (°F)	SW-OUT (°F)	Δ T SW	Air Flow (SCFM)
Shell-&- Tube BAC	568.85	138.20	430.65	70.47	75.02	4.55	1707
Predicted HP BAC	568.85	190	378	70.47	78.45	7.98	1707

The tasks to be followed to meet the predicted performance in Table 5 are listed below.

**In summary:**

From the recorded data and technical discussions over that past few weeks, it's felt that all of the above issues are or could be contributing to the lack of cooler performance. No one gets the sense that it's one thing causing this problem. However it's felt that the thermal resistance is the most significant. From the discussions it's a lot clearer that controlling the thermal resistance of the heat pipe is the key to control wall temperatures on the seawater side of the pipes. Since we are building in this resistance its going to narrow the range of a coolers performance. Designing the cooler to run at 925 °F and then to operate it at 500 °F to 600 °F is not the way we should have been designing. Because of this, a closer look will be taken on the operational design states in the redesigned tube sheet. In short its certain that a heat pipe cooler will never perform over a large range of conditions as well as thin wall shell & tube exchangers. There is nothing wrong with this as long as were solving a long time problem with scaling, which will reduce maintenances, and hazardous material cost and improves system reliability. One needs to clearly understand what these restrictions will be. The efforts put forth in completing the prototype install have achieved a lot. It's provided a good test platform, all drawings and installation documentation are completed, we have reduced this reinstall cost to approx a \$25K or less. If it can be clearly demonstrated that the reinstall will be successful the ships has indicated that we would be welcome back to test once we have a ready HP-BAC

**Task to Accomplish Redesign of Small Coupon and Full-Scale for Reinstall**

**1. Post Evaluation of HP-BAC:** Once the prototype cooler is pulled and returned to NSWC testing will be run on the heat pipes to establish if they are all operational and to identify pipe thermal resistances. This will determine what the characteristics of the pipes were and help in the improvements of the redesign.

**2. Review and Confirm Design Requirements:** Thermacore and NSWC will review the design requirements and select those that are the most important. Thermacore recommends designing to 700 °F and maintaining the requirement for heat pipe wall temperatures under 150 °F to eliminate calcareous deposits.

**3. Reduce Heat Pipe Thermal Resistance:** The best method to reduce heat pipe thermal resistance is to reduce the wall thickness. Heat pipes will be made and tested to measure and confirm the thermal resistance value. The objective is a thermal resistance value of 0.035°C/W. This value will be confirmed by testing at the intended heat load in the final application. Fabricate 6 individual heat pipes with fins for thermal resistance testing. Run these thermal performance tests with fins to determine performance and resistance. Incorporate the smaller wall thickness heat pipe to reduce resistance, class 700 or class 1650 vice the class 3300 that was used for the prototype.

- 2 pipes - with class 3300 pipes one 9" long, one 12<sup>3</sup>/<sub>4</sub>" long
- 2 pipes – with class 1600 pipes one 9" long, one 12<sup>3</sup>/<sub>4</sub>" long
- 2 pipes – with class 700 pipes one 9" long, one 12<sup>3</sup>/<sub>4</sub>" long

**4. Improved Fin Attachment and Fin Count:** The brazing of the fins on the heat pipes in the first assembly did not work very well. Brazing tests will be conducted to improve this braze technique. NSWC and Thermacore will work on this jointly. Casting is another option to investigate. Thermacore is also proposing to increase the fin count on the airside to 10fins/inch. If funded incorporate the new fin casting assemblies and joining process developed under MANTECH program into the redesign efforts. These efforts should bear better conduction and less thermal resistance into the heat pipes.

**5. Subscale Unit Fabrication and Test** To confirm the design of the assembly, Thermacore will be contracted to build a sub-scale unit (1/4 scale) and test it under simulated flow conditions. The subscale unit will be tested at NSWC or Wyle Laboratories. The measured performance will be compared against the predicted performance to confirm the results. Upon successful testing, fabrication of the full-scale unit will proceed. The fabrication of the sub-scale unit will be incorporate 30 to 50 multi height pipes with various fin densities. This effort will also quantify through modeling and testing what the heat pipe performance characteristics will be i.e. thermal resistance and heat duty etc.

**6. Full-Scale Tube Sheet:** After successful sub-scale testing, a full-scale tube sheet will be fabricated. The tube sheet will be integrated with the modified shell sections for reinstallation onto the DDG-61 ship for testing. This new redesign of full scale tube sheet will also address new flow pattern criteria.

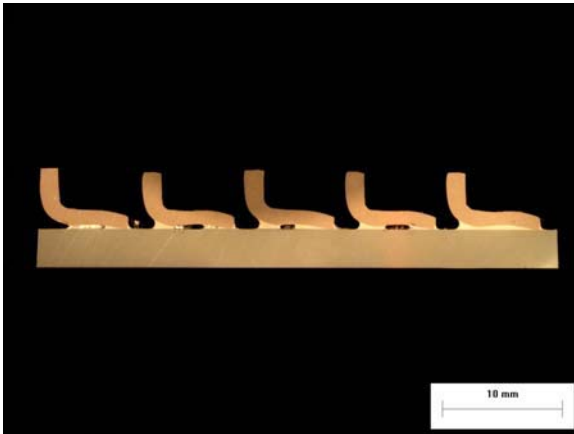
**7. Reconfigure Both Shell Sections Internals**

- to provide optimum cross flow pattern through the cooler
- to accommodate the multi height pipes
- to close off an flow-by gap areas
- to accommodate delt P data monitoring across the cooler

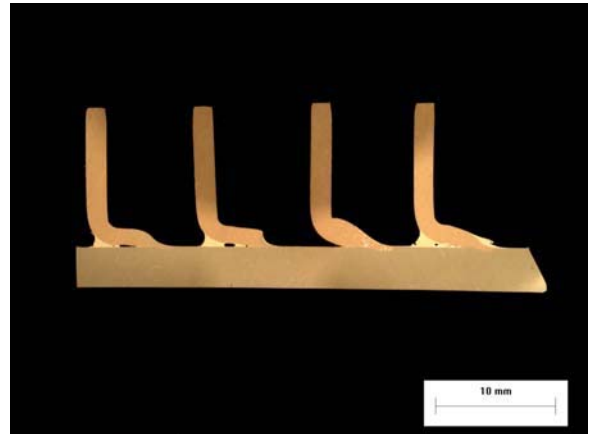
**8. Prior to Reinstall:** On the completed full-scale cooler perform a hydro test and run a 30 to 40 hour thermal performance test. Evaluate the coolers performance measured vice predicted. Define what the operational characteristics of the cooler will between 500 °F to 700 °F with air flows between 1500 SCFM to 2500 SCFM

**9. Install redesign cooler:** onto DDG-61 USS Ramage and perform testing for 1 year

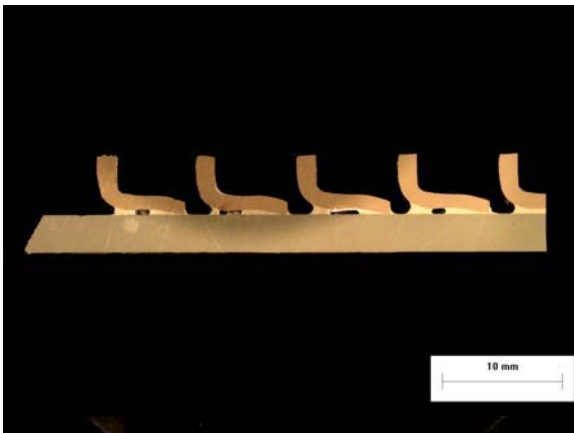
**Figure 1 from EWI Joining Report**



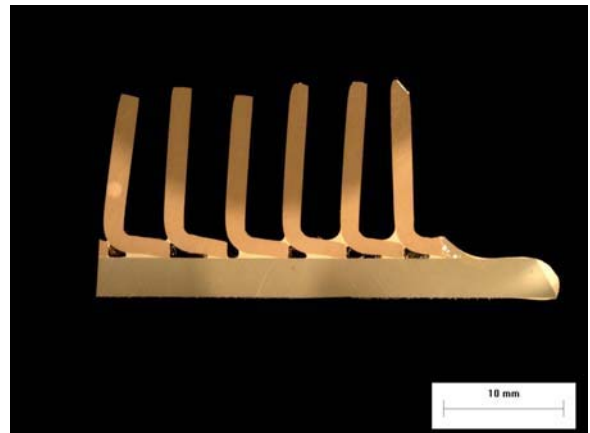
**Figure 20 - Braze Assembly #1 Macro**



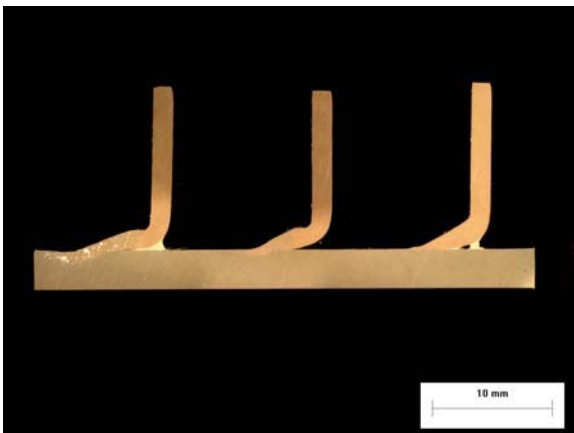
**Figure 23 - Braze Assembly #4 Macro**



**Figure 21 - Braze Assembly #2 Macro**



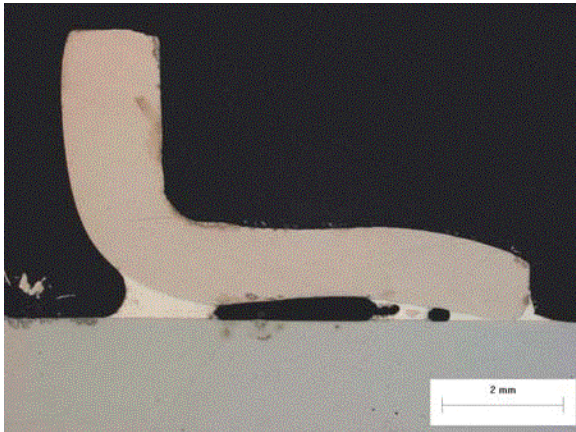
**Figure 24 - Braze Assembly #5 Macro**



**Figure 22 - Braze Assembly #3 Macro**

Selected sections with voids were further sectioned, mounted in bakelite, and polished. The micrographs in Figure 25 through Figure 29 were taken from these polished samples.

**Figure 2 From EWI Joining Report**



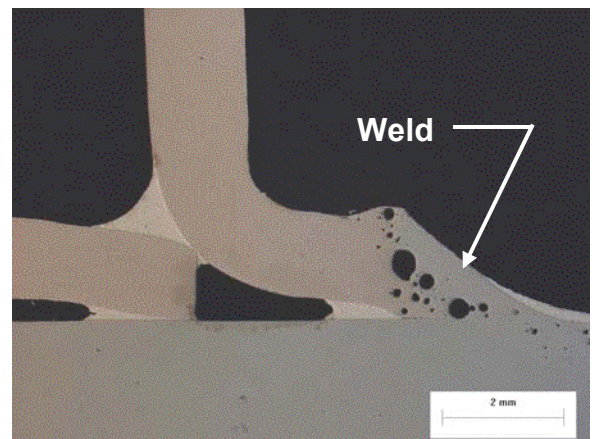
**Figure 25 - Assembly #1 Braze Joint Voids with Bowed Fin Leg**



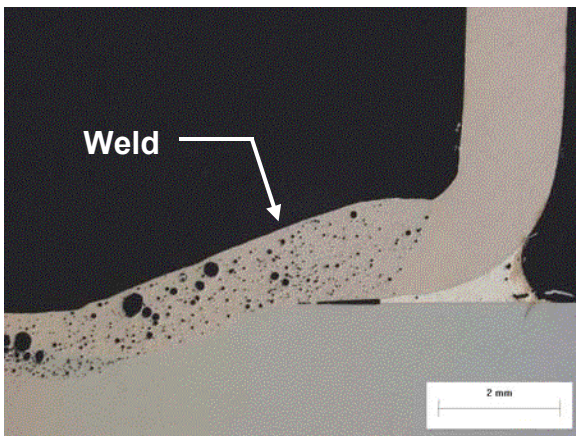
**Figure 28 - Assembly #4 Braze Joint Voids with Porosity in Adjacent Weld**



**Figure 26 - Assembly #2 Braze Joint Voids with Bowed Fin Leg**



**Figure 29 - Assembly #5 Braze Joint Voids with Porosity in Adjacent Weld**



**Figure 27 - Assembly #3 Braze Joint Voids with Porosity in Adjacent Weld**

The results indicate that the brazed fin-to-tube assemblies have moderate braze quality. Voids were found in all five of the examined assemblies.

Figure 25 and Figure 26 are the micrographs of brazed joint assemblies #1 and #2. The likely cause of voids in these joints is the bowed shape of the fin legs. Bowed legs create a joint gap too large to retain the liquid alloy during brazing, thus causing voids or incomplete fill. The legs should be straight to provide a uniform joint gap prior to brazing. The voids may also be

Figure -3 Heat Exchanger Cross Sections

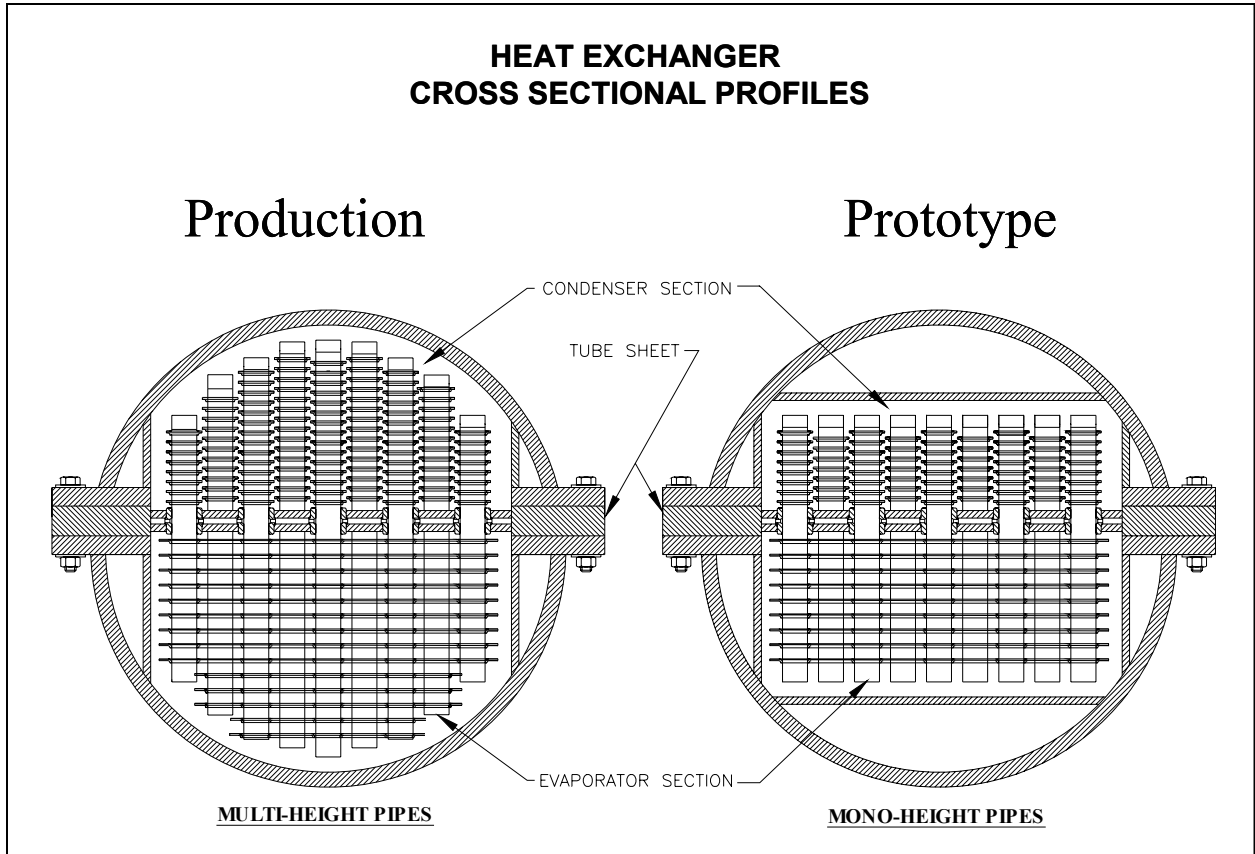
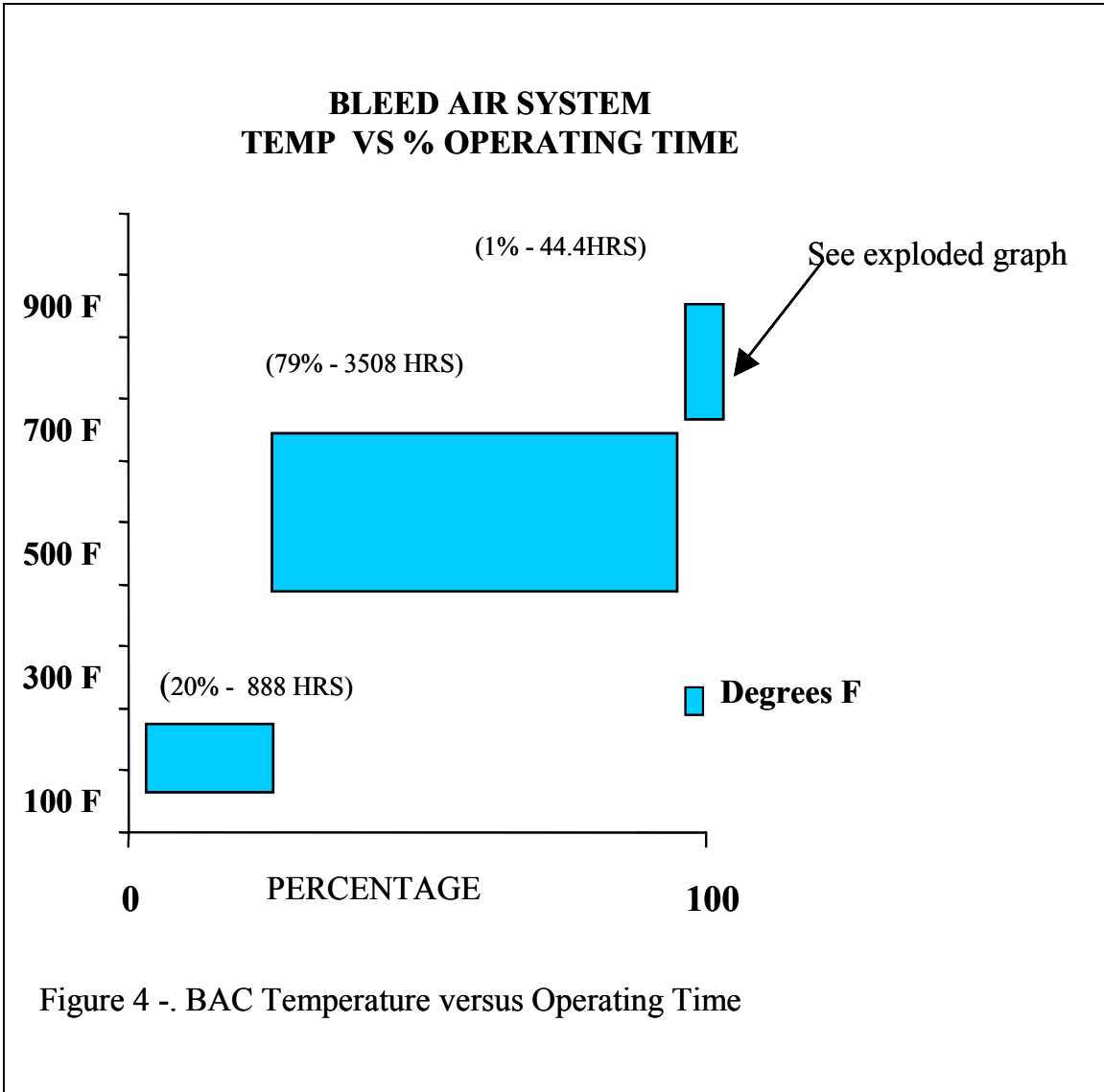




Figure 4 Temperature vs. Operating Time



**Appendix A-B**  
**Ship Survey Report**

---

## Ship Survey Report

**Location:** Naval Station Norfolk

---

**Subject:** Bleed Air Cooler Replacement / Demonstration of Heat Pipe Cooler Technology being supported under

**ESTCP: PP-0302,** Elimination of Acid Cleaning of High Temp Salt Water Heat Exchangers

---

**Report Date:** 01 April 2004

**Event Date:** 22-24 March 2004

**Event Location:** Naval Station Norfolk

**Submitted by:** Denis Colohan

---

**Purpose of Event:** Perform a ship check on USS RAMAGE (DDG 61) to assess the design and installation considerations for replacement of the Masker Bleed Air Cooler with a heat pipe technology cooler. For scheduled install during the ships availability in Sept – Nov 04

---

### Principal Personnel Involved:

Steve Verosto	NSWCCD Code 632
Denis Colohan	NSWCCD Code 983
John Horsley	DDG 61 PE
LCDR Moriarty	DDG 61 XO
LT Patrick Bennett	DDG 61 CHENG
LT Philip Riggs	DDG 61 MPA
GSMCS Ken Lentz	DDG 61 Eng Dept LCPO
GSMC Quillopo	DDG 61 MER 1 CPO
GSM1 Wilson	DDG 61 MER 1 LPO
GSM2 Mooney	DDG 61 MER 1
Bob Hampton	RCI Project Director

LT Bennett is departing his post on DDG 61 on 29 March 2004 and is being replaced by LT Chris Simmons

CCS (757) 445 6045

quillopm@ramage.navy.mil

---

lentzk@ramage.navy.mil  
riggsp@ramage.navy.mil

---

### **Trip Summary:**

An inbrief was held with ship personnel and port engineer on the morning of 3/23/04. The CHENG indicated that most of the ship's seawater piping was 90/10 cuni and that any upgrades should be 70/30 cuni. The ship indicated that they do not take bleed air directly from the gas turbines but from the SSTGs. Additionally the ship indicated that they always run both Masker systems (one in MER 1 and one in MER 2) simultaneously and that other than during speed restrictions the ships runs both the Prairie and Masker systems during underway periods. The ship suggested checking the condition of the seawater strainers and repairing if necessary prior to the evaluation.

The following provides a list of concerns raised by the ship during the inbrief and discussion of the technology and installation plans.

- 1) Ship is concerned about the constant expansion and contraction and subsequent failure of the heat pipe fin welds and welds at the tube sheet resulting from temperature shock and normal differentials.
- 2) Risk of a cooler failure must be addressed. Spare internals would be an option they would consider. Another option would be to pipe the cooler such that the inlets are flanged and can be replaced with the old shell and tube heat exchanger if an irreparable failure does occur. The ship's main concern is that these coolers are needed for their starts and the back-up HP air starts are unreliable.
- 3) The ship would like to have computational models run that determine what happens to the cooler and pipes when the seawater temperature is 40-50°F.
- 4) The ship would like to have computational models run that determine what happens if you remove the fins from the seawater side of the cooler. Maintenance issues are the concern that drove this question.

- 5) The port engineer does not want the ship deploying without running stateside tests.

Inspection of the cooler arrangements in MER1 and MER2 were accomplished. These inspections revealed that the most efficient location to accomplish the prototype installation is MER 1. It was determined that the bleed air inlet piping was identified by 3-300-105B16-A182-F321 stainless steel (it should be noted that this data was pulled from the Prairie cooler bleed air inlet).

The following is a list of logistic information obtained during the space evaluations.

Masker Cooler in MER 1	Wiegmann & Rose (FSCM 78730)
P/N 1203 SUN-2P	Serial G00325
Type E Class 2	4420-DAO-66-5189
Contract # N00024-90-C-2800	Manufactured 01/92

**Masker System pressure and temperature gages in MER-1:**

Masker Air Pressure	MA-GA-1	Calibrated 11/06
Masker Inlet Pressure Seawater	SW-GA-057	No cal required
Masker Outlet Pressure Seawater	SW-GA-058	No cal required
Masker Orifice Pressure Seawater Diff	SW-GA-059	No cal required
Masker Seawater Outlet Temperature	SW-TH-007	No cal required
Masker Air Outlet Temperature	MA-TH-1	Calibrated 1/06

---

**Submitted By:** Denis Colahan

**Signature:** \_\_\_\_\_ **Date:** \_\_\_\_\_

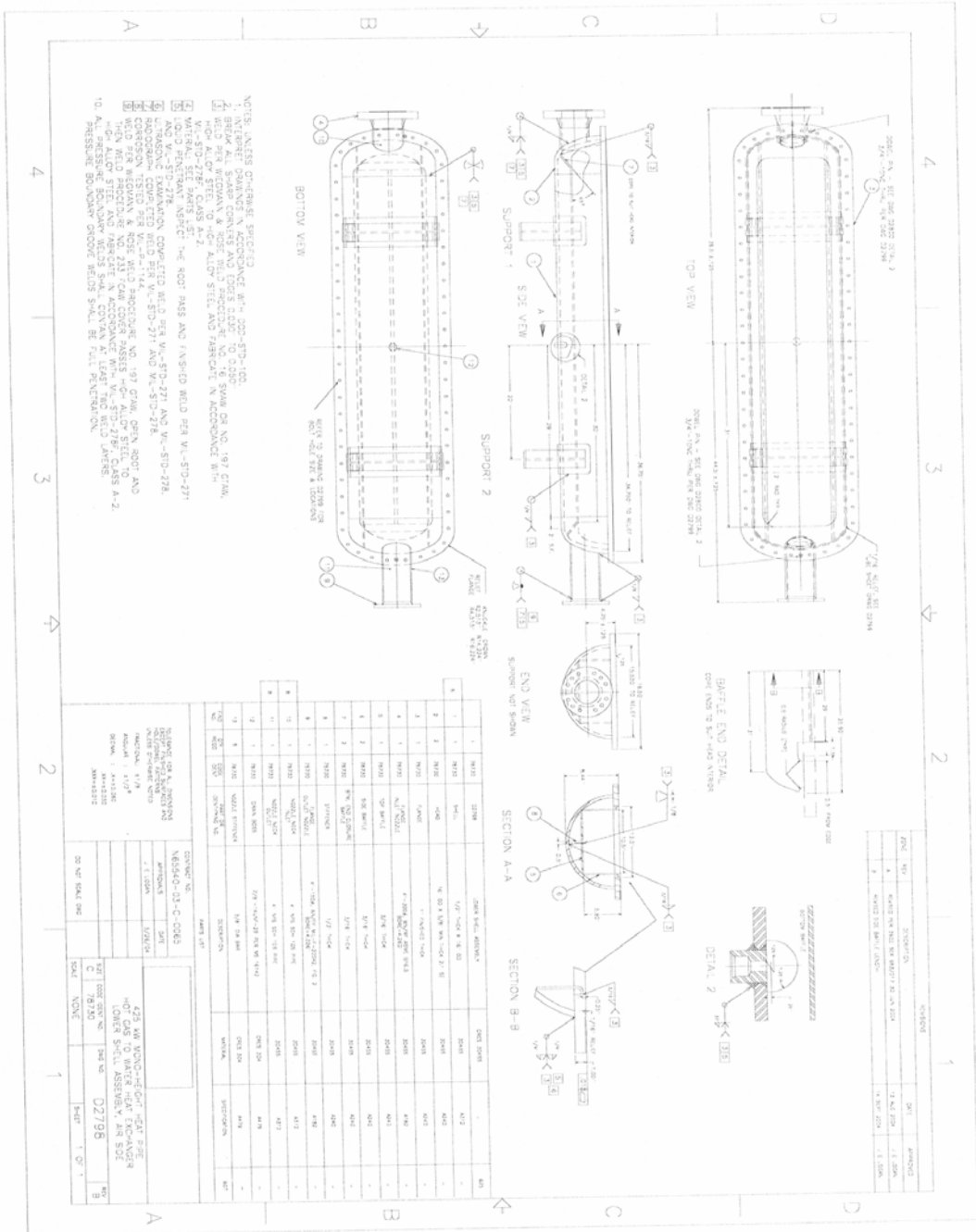
## **Appendix A-C**

### **Heat Pipe Design and Development**



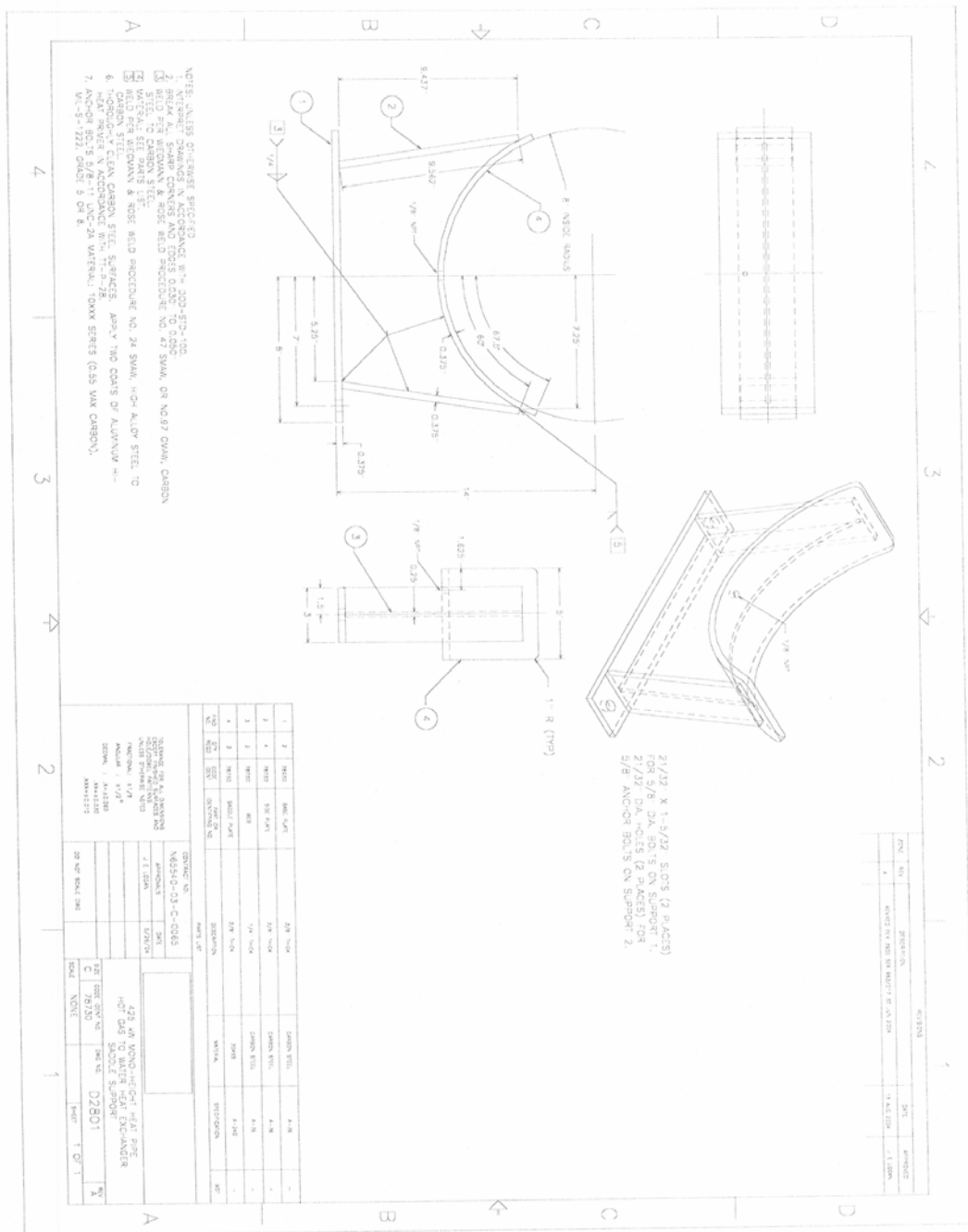


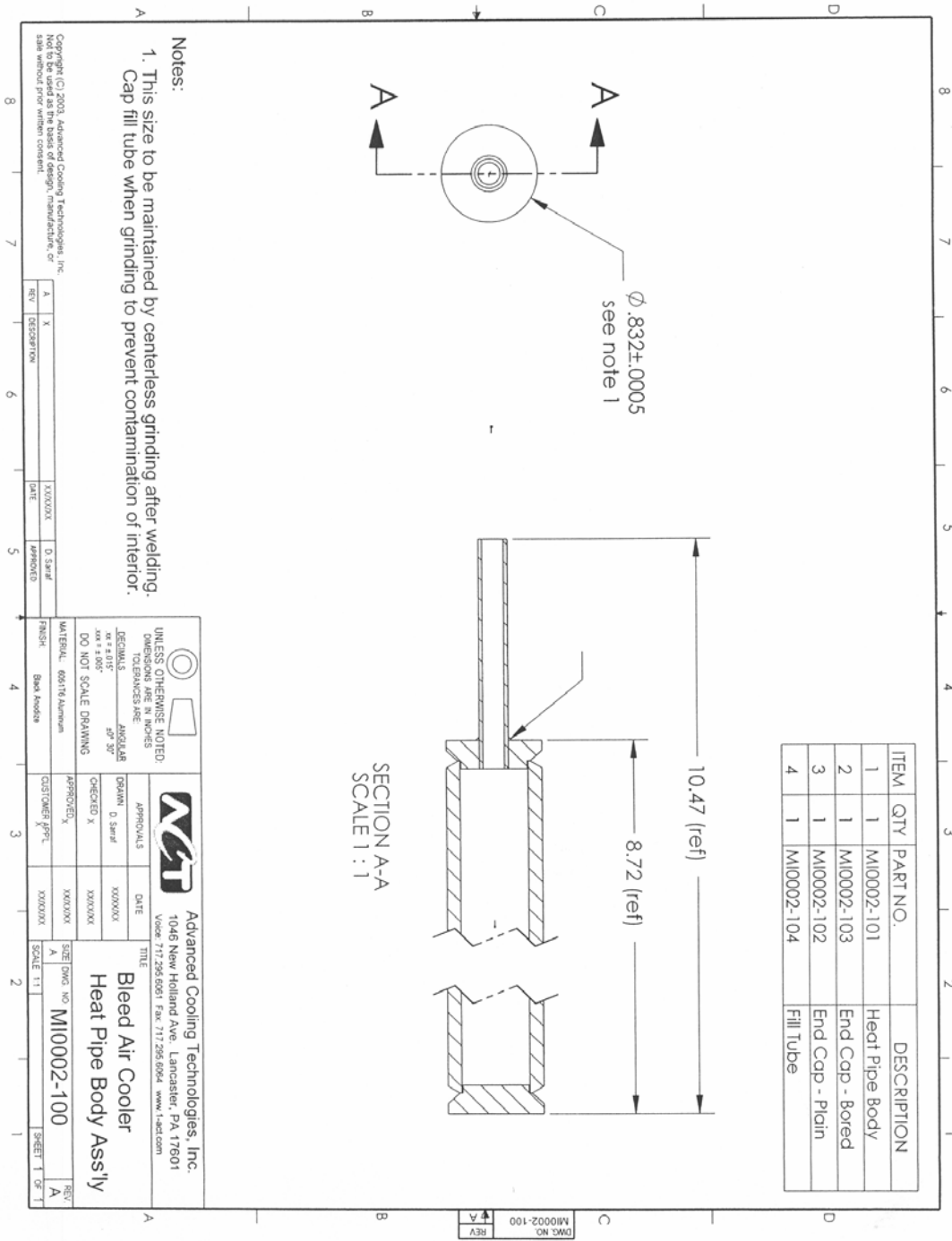




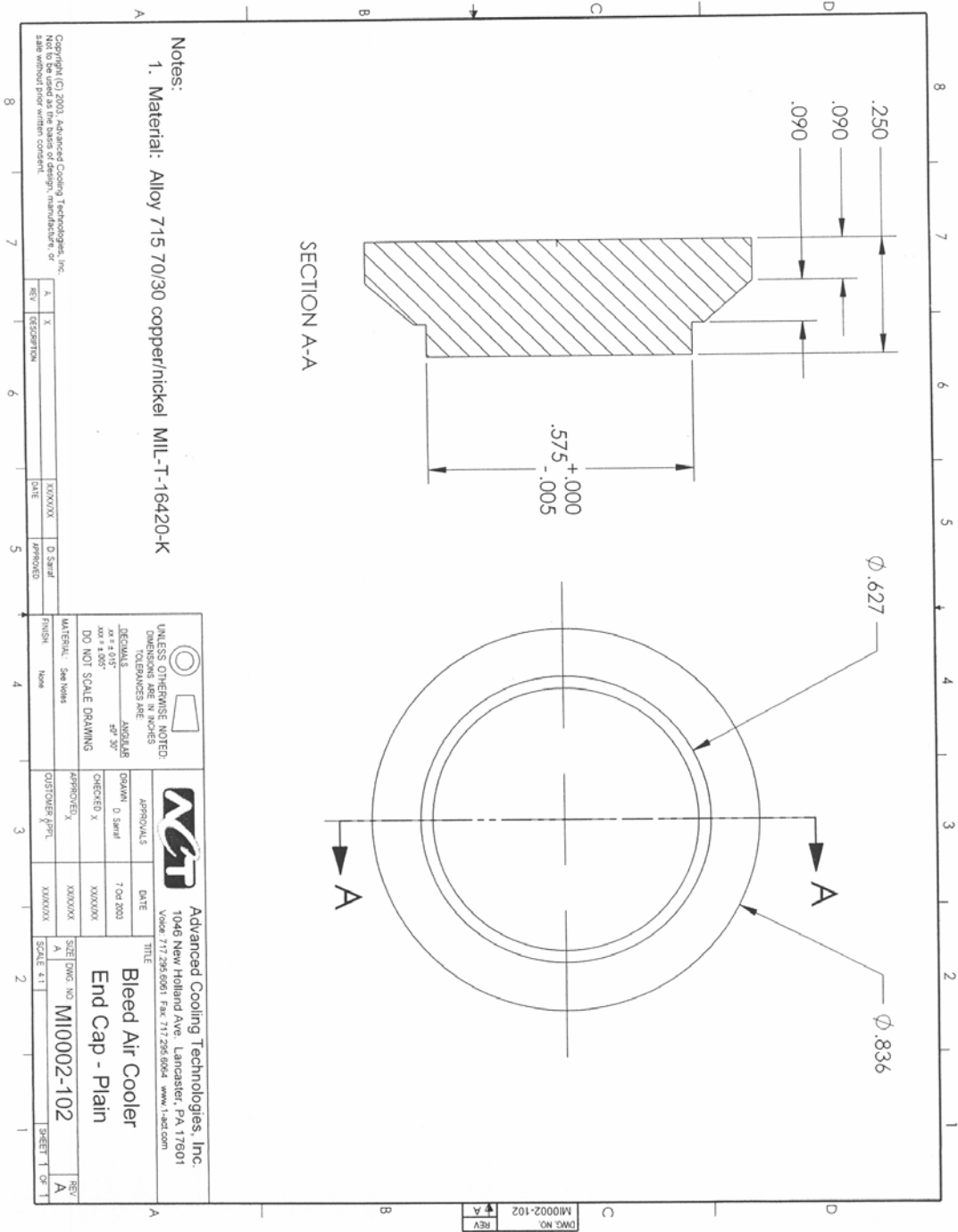


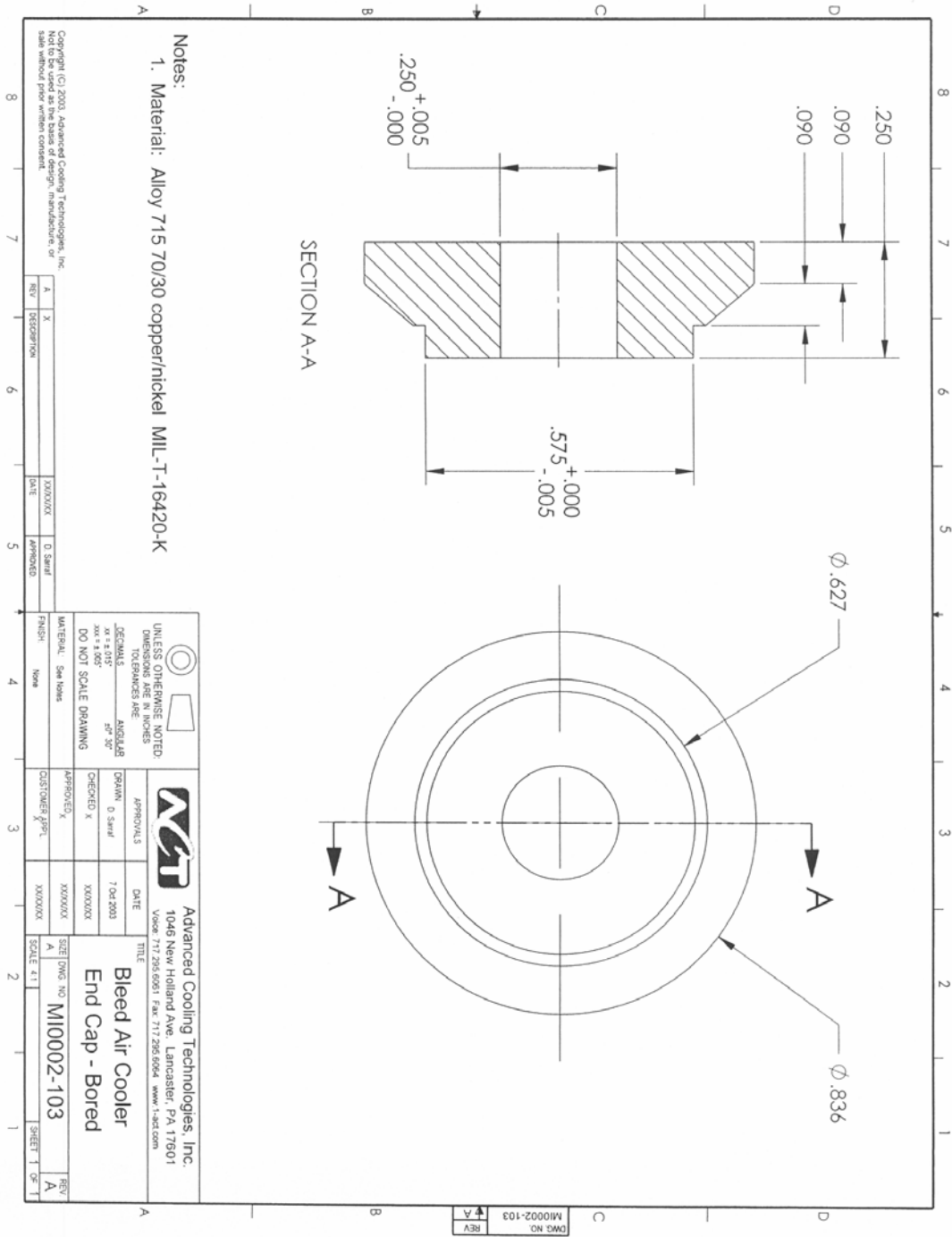












**Notes:**

1. Material: Alloy 715 70/30 copper/nickel MIL-T-16420-K

Copyright (C) 2003, Advanced Cooling Technologies, Inc.  
 Not to be used as the basis of design, manufacture, or  
 test without prior written consent.

REV	DESCRIPTION	DATE	APPROVED
A	X	10/00/00	D Sawd

UNLESS OTHERWISE NOTED DIMENSIONS ARE IN INCHES	
DECIMALS	ANGULAR
$\pm .005$	$\pm 30^\circ$
DO NOT SCALE DRAWING	
MATERIAL: See Notes	FINISH: None

APPROVALS	DATE
DRAWN: G Sawd	7/04/2003
CHECKED: X	X/00/00
APPROVED: X	X/00/00
CUSTOMER SPECL	X/00/00

**Advanced Cooling Technologies, Inc.**  
 1046 New Holland Ave, Lancaster, PA 17601  
 Voice: 717.295.9261 Fax: 717.295.6264 www.1act.com

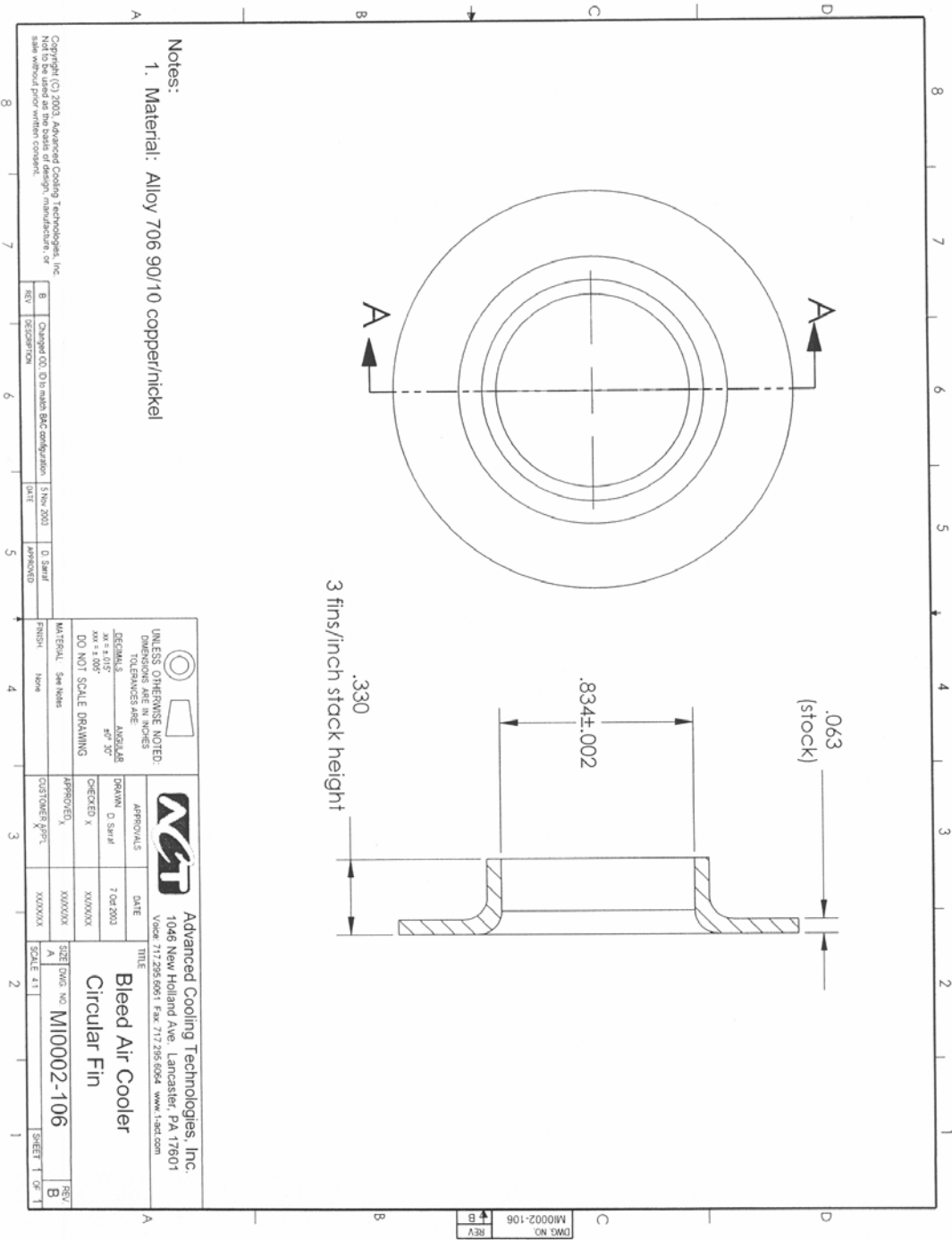
**Bleed Air Cooler**  
**End Cap - Bored**

SIZE: DWG NO: M10002-103  
 SCALE: 4:1

REV	DATE
A	10/00/00
SHEET 1 OF 1	

DWG NO.	M10002-103
REV	A





Notes:  
 1. Material: Alloy 706 90/10 copper/nickel

Copyright (C) 2003, Advanced Cooling Technologies, Inc.  
 Not to be used as the basis of design, manufacture, or sale without prior written consent.

REV	B	Change CO. D in main SAC configuration	5 Nov 2003	D. Smith
REV	A	DESCRIPTION	DATE	APPROVED

UNLESS OTHERWISE NOTED: DIMENSIONS ARE IN INCHES TOLERANCES ARE: DECIMALS ANGULAR X = ±.015 XX = ±.005 DO NOT SCALE DRAWING	APPROVALS DRAWN: D. Smith CHECKED: X APPROVED: X	DATE 7 Oct 2003 XXXXXX XXXXXX
---	---	--

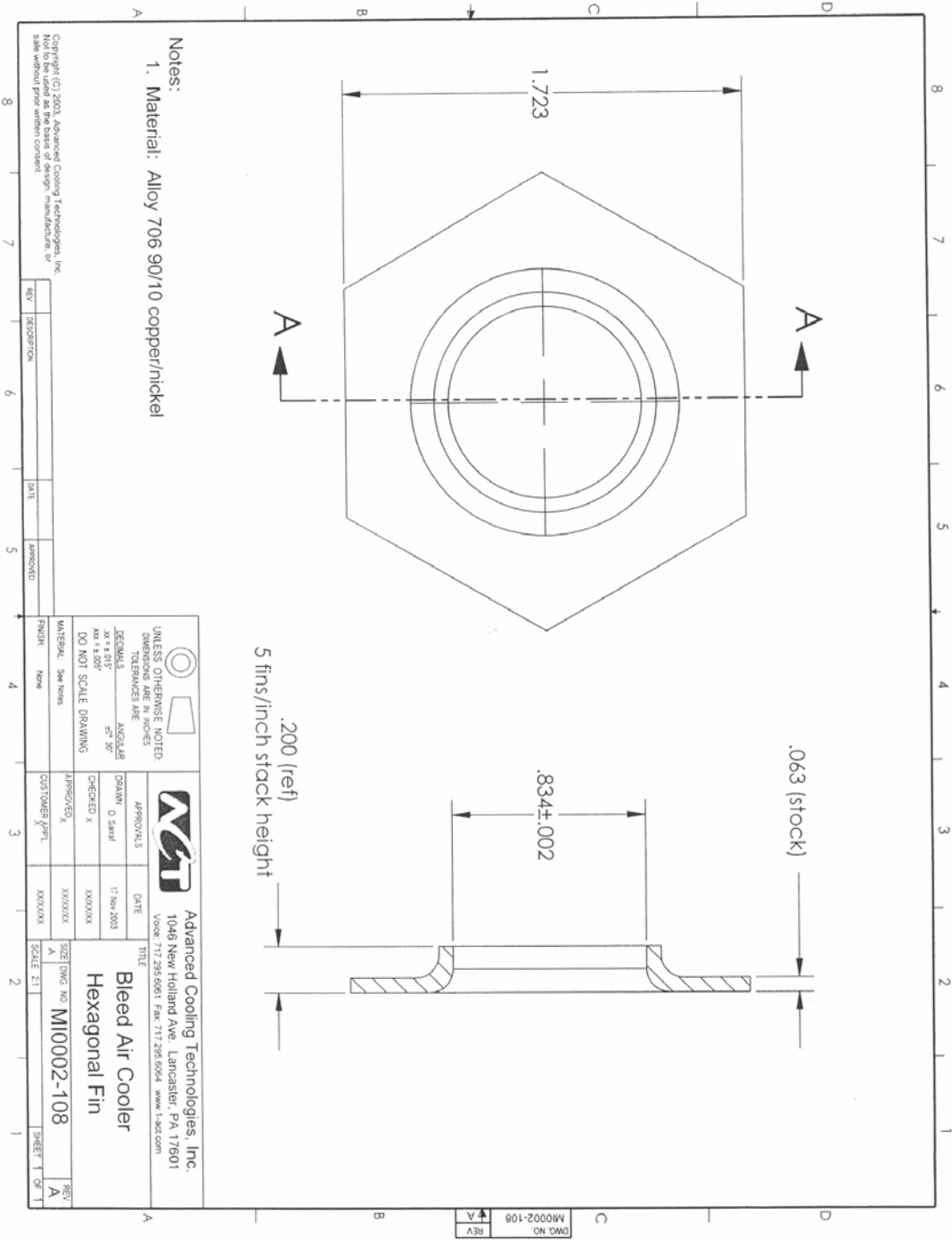
**Advanced Cooling Technologies, Inc.**  
 1046 New Holland Ave., Lancaster, PA 17601  
 Voice: 717.225.6051 Fax: 717.225.6054 www.1-act.com

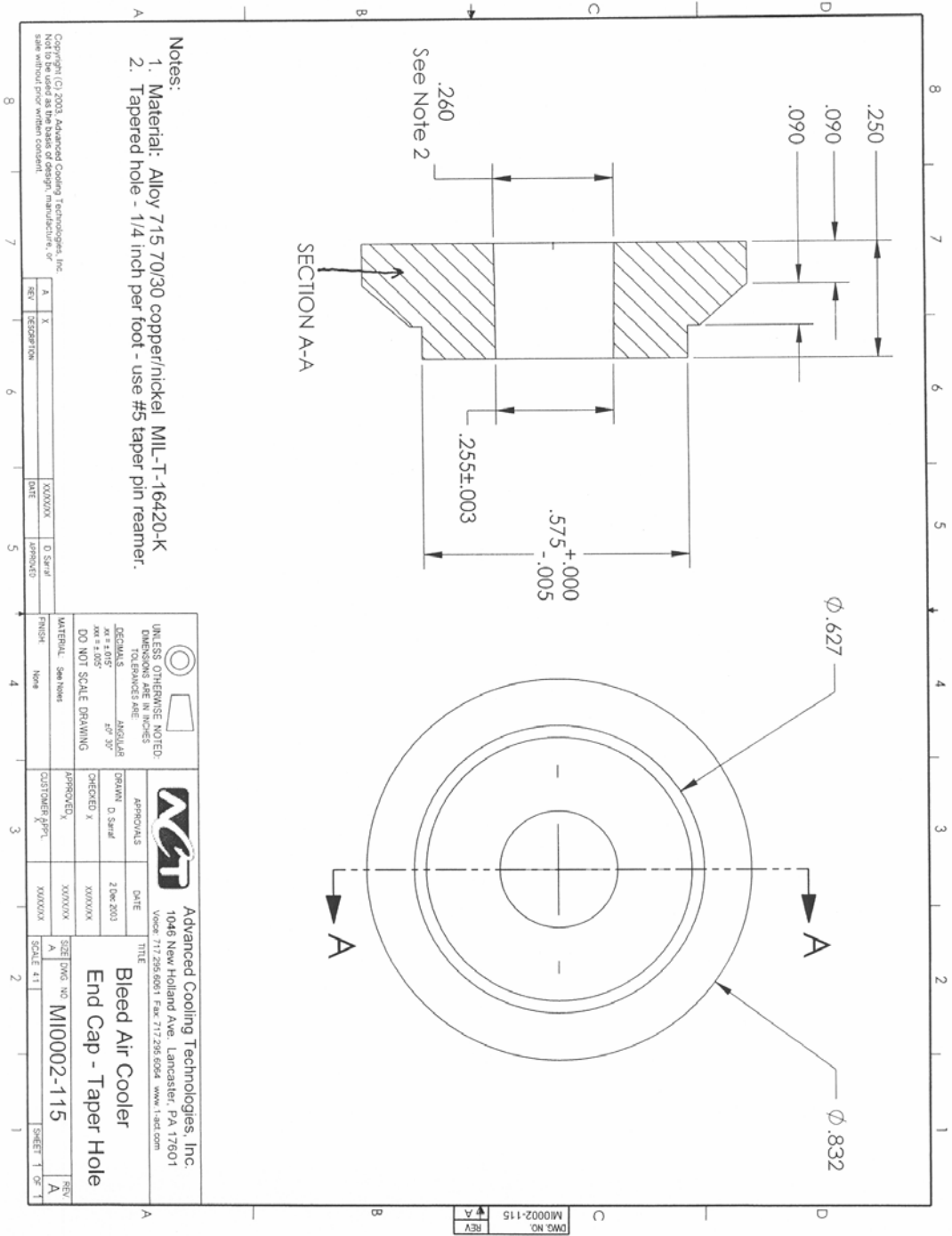
**Bleed Air Cooler**  
**Circular Fin**

SIZE: DWG NO: M10002-106  
 SCALE: 4:1

REV	B
SHEET	1 OF 1

REV	B
DWG NO	M10002-106





Copyright (C) 2003, Advanced Cooling Technologies, Inc.  
 Not to be used as the basis of design, manufacture, or sale without prior written consent.

REV	A	X	DESIGNATION	DATE	APPROVED

UNLESS OTHERWISE NOTED, DIMENSIONS ARE IN INCHES. TOLERANCES ARE:

DECIMALS ANGULAR  
 .015 ± .005 2° ± 30'  
 .0005 ± .0005  
 DO NOT SCALE DRAWING

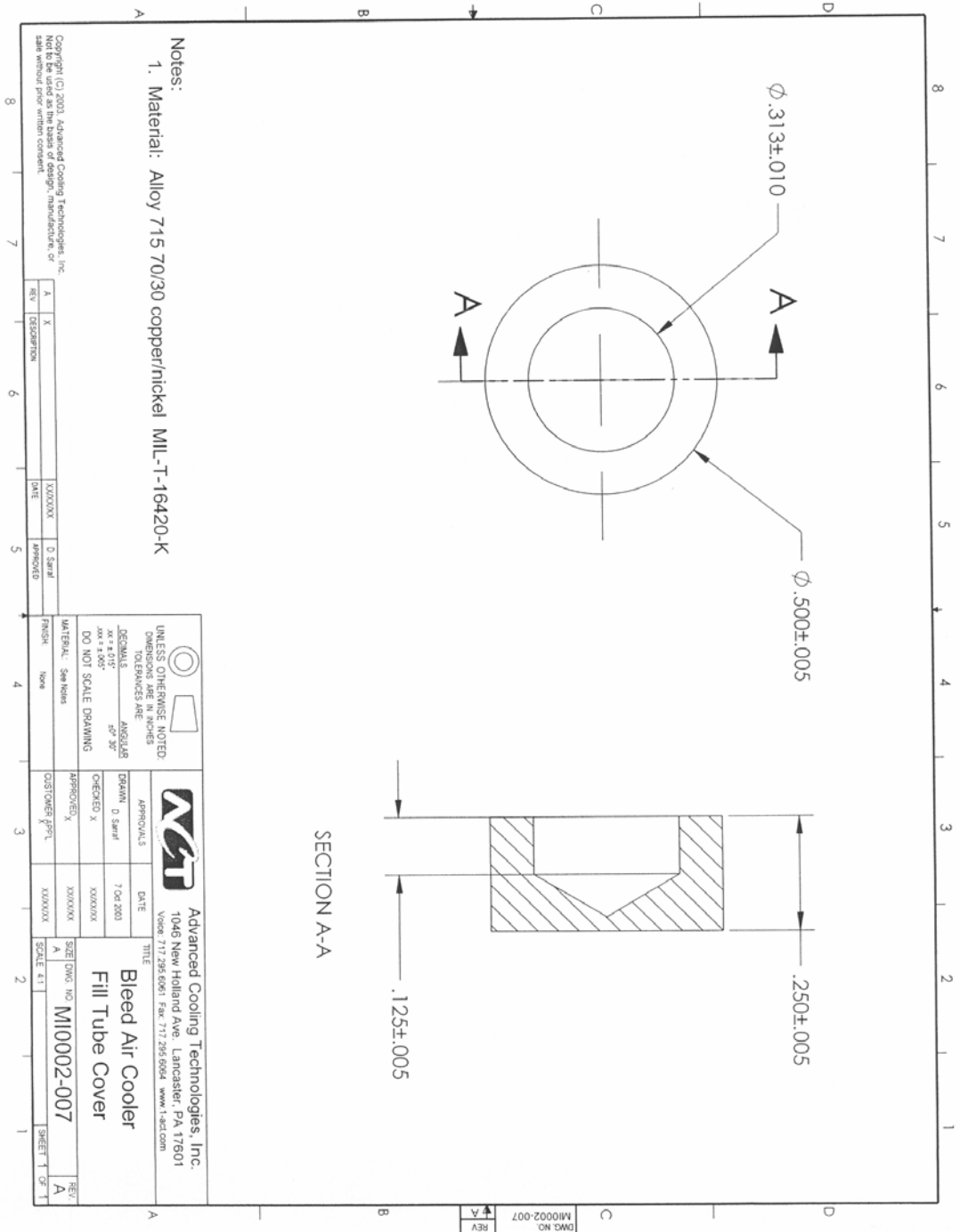
APPROVALS	DATE
DRAWN D. Saur	2/06/2003
CHECKED X	XXXXXXXX
APPROVED X	XXXXXXXX
CUSTOMER APP'L	XXXXXXXX

Advanced Cooling Technologies, Inc.  
 1046 New Holland Ave, Lancaster, PA 17601  
 Voice: 717.295.6001 Fax: 717.295.6054 www.1-acd.com

TITLE: Bleed Air Cooler  
 End Cap - Taper Hole

SIZE: DWG NO: M100002-115  
 SCALE: 4:1

DWG NO.	M10002-115
REV	A



Notes:  
 1. Material: Alloy 715 70/30 copper/nickel MIL-T-16420-K

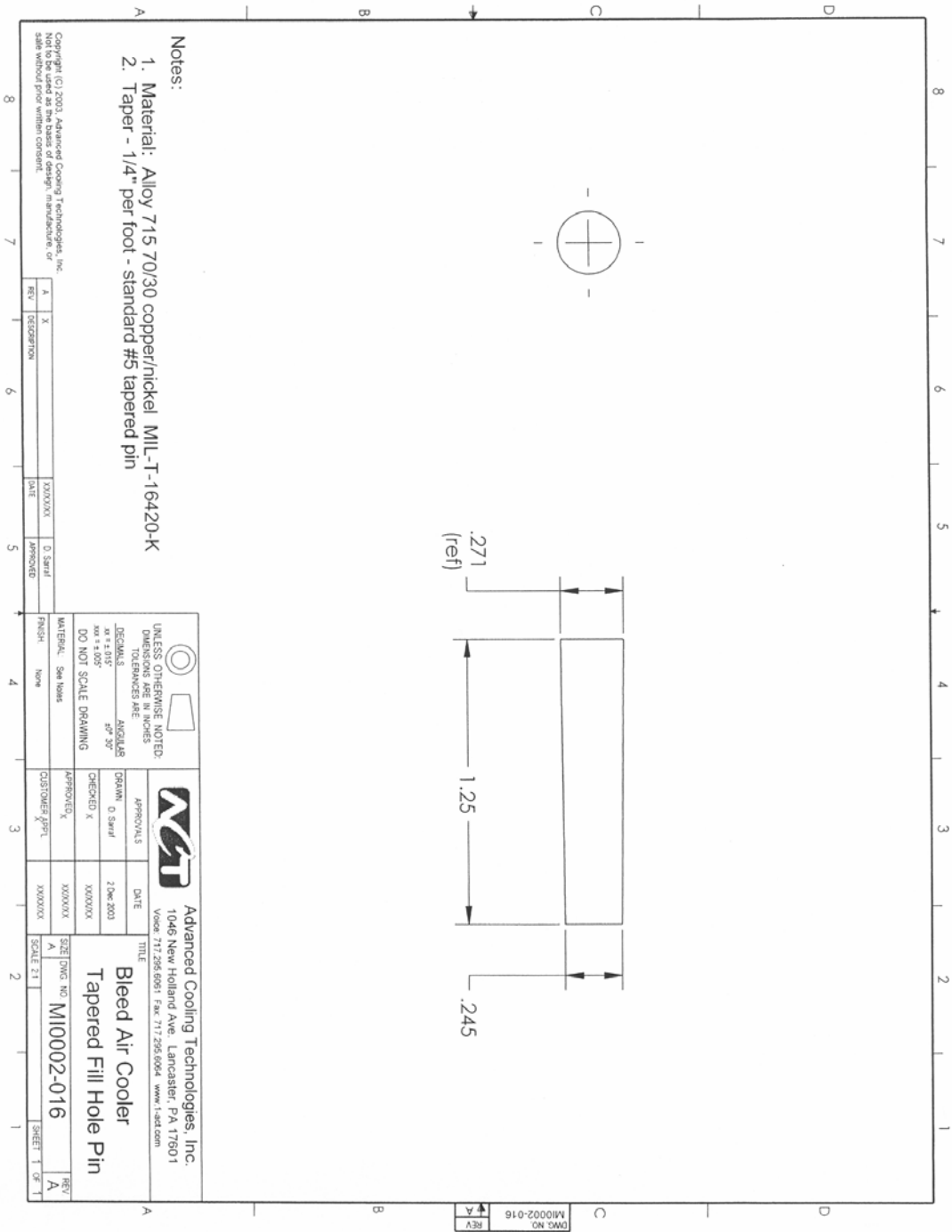
Copyright (C) 2003, Advanced Cooling Technologies, Inc.  
 Not to be used as the basis of design, manufacture, or sale without prior written consent.

REV	DESCRIPTION	DATE	APPROVED
A	X	X/00/00	D Samal

UNLESS OTHERWISE NOTED DIMENSIONS ARE IN INCHES TOLERANCES ARE:	ANGULARS ±.01°
DECIMALS ±.005	±.01°
DO NOT SCALE DRAWING	

		<b>Advanced Cooling Technologies, Inc.</b> 1045 New Holland Ave. Lancaster, PA 17601 Voice: 717.295.0261 Fax: 717.295.0264 www.1-act.com	
APPROVALS	DATE	TITLE	REV
DRAWN: D Samal	7/04/2003	Bleed Air Cooler	A
CHECKED: X	X/00/00	Fill Tube Cover	
APPROVED: X	X/00/00	SIZE: DWG NO: M10002-007	
GASTOMER PRTL	X/00/00	SCALE: 1:1	SHEET 1 OF 1

DWG NO	M10002-007
REV	A



- Notes:
1. Material: Alloy 715 70/30 copper/nickel MIL-T-16420-K
  2. Taper - 1/4" per foot - standard #5 tapered pin

Copyright (C) 2003, Advanced Cooling Technologies, Inc.  
 Not to be used as the basis of design, manufacture, or sale without prior written consent.

REV	DESCRIPTION	DATE	APPROVED
A	X	XX/XX/XX	D. Spaul

UNLESS OTHERWISE NOTED:  
 DIMENSIONS ARE IN INCHES  
 TOLERANCES ARE:  
 DECIMALS ANGULAR  
 AS ± .015° 20°-30°  
 AS ± .015°  
 DO NOT SCALE DRAWING

MATERIAL: See Notes  
 FINISH: None



Advanced Cooling Technologies, Inc.  
 1046 New Holland Ave, Lancaster, PA 17601  
 Voice: 717.295.6951 Fax: 717.295.6964 www.1-act.com

APPROVALS	DATE	TITLE
DRAWN: D. Spaul	21Nov-2003	Bleed Air Cooler
CHECKED: X	XX/XX/XX	Tapered Fill Hole Pin
APPROVED: X	XX/XX/XX	
CUSTOMER SPEC.	XX/XX/XX	
SIZE: DWS NO. M100002-016	SCALE: 2:1	REV: A
SHEET 1 OF 1		

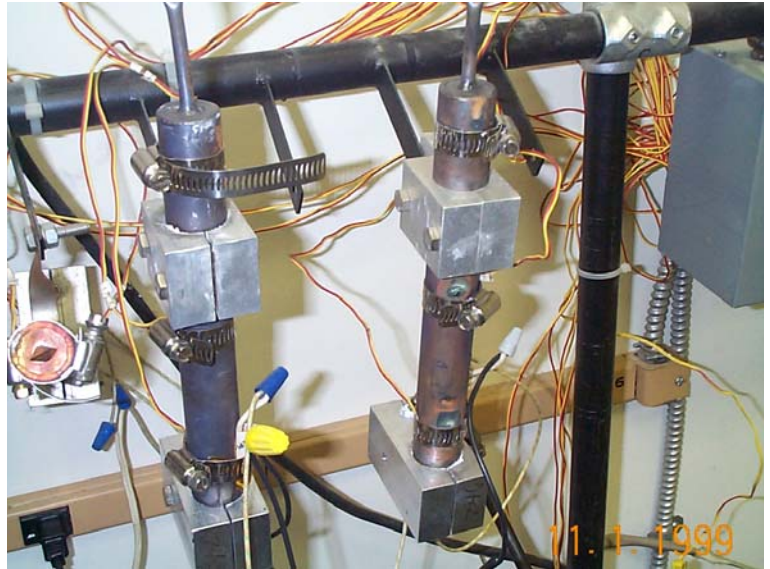
DWS NO.	M10002-016
REV	A

## Heat Pipe Design and Development

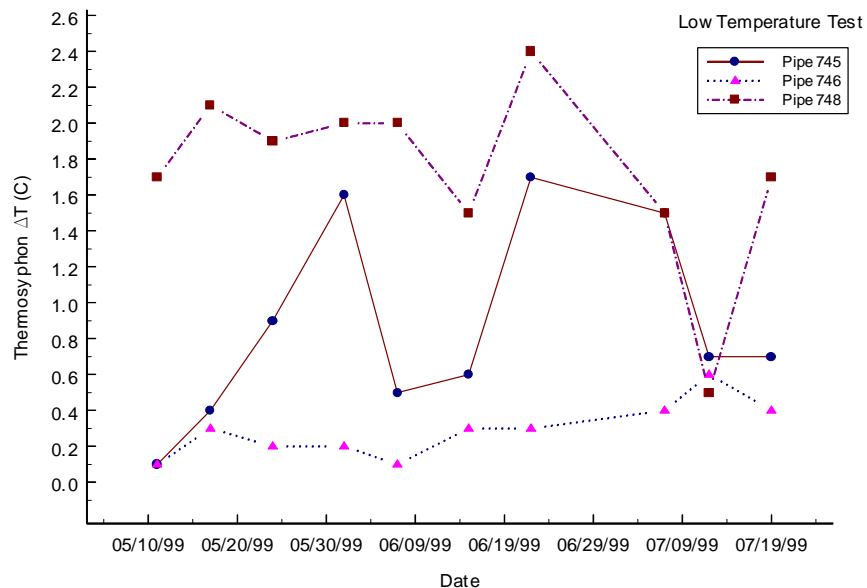
By orienting the heat exchanger so that the hot side is on the bottom made it possible to utilize thermosyphons heat pipes which return liquid by gravity rather than capillary pumping. This allowed the transport of very high heat levels (2880 watts) through modest sized heat pipes (1.05" or 0.84" OD).

### Life Test Pipes (Materials Compatibility)

Four heat pipes were fabricated in mid 1999 for life testing. Numbers 745 and 746 were 90-10 copper-nickel and numbers 747 & 748 were 70-30 copper nickel. Number 747 was damaged during processing. The three remaining pipes were placed on life test. Figure C1 shows pipes 745 and 746 on the test rack for these early "low temperature" tests. Figure C2 shows the  $\Delta T$  test results for the first 1680 hours. The variation is within instrument drift and thermocouple error compounded by varying ambient temperatures in the room. The magnitudes of the  $\Delta T$ 's show no indication of non-condensable gas generation.



**Figure C1. Pipes 745 and 746 on Life Test Rack**



**Figure C2. Delta-T performance of Life Test Heat Pipes (For 1680 hours of "low temperature" testing)**

By this point in the program, it was evident that the heat pipes would operate at much higher temperatures and that 70-30 Cu-Ni would be the material of choice, so pipe 748 was placed on high temperature test. In the low temperature tests, the 75 watt heaters were run constantly, in the high temperature test a cutoff switch was used to throttle a 250 W heater. The throttling produced larger temperature swings. Figure C3 shows this unit under test. It was enclosed in a shield for containment purposes in case a cutoff-switch failure should lead to a burst pipe

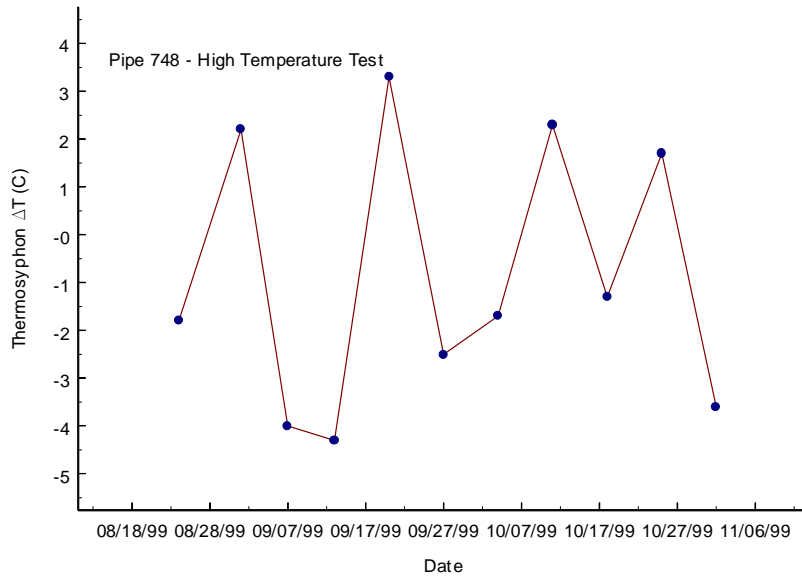


**Figure C3. HP#748 on High Temp. Life Test**

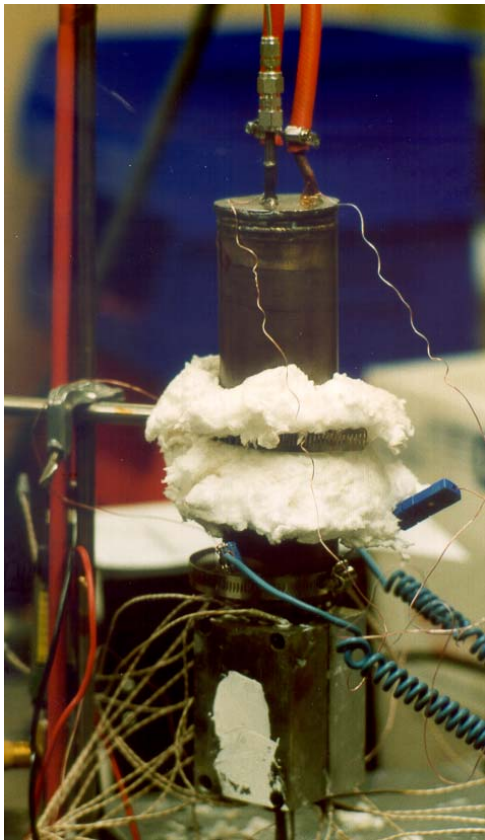
Figure C4 shows the pipe's  $\Delta T$  performance over the first 1750 hours. These are within normal performance measurements and indicate that the pipe is not gassing up. The pipes were run until the life test facility was relocated in 2001. They logged 7,344 hours of operation. Although no data were taken after the end of the program. These pipes are still available.

### **Heat Pipe Characterization**

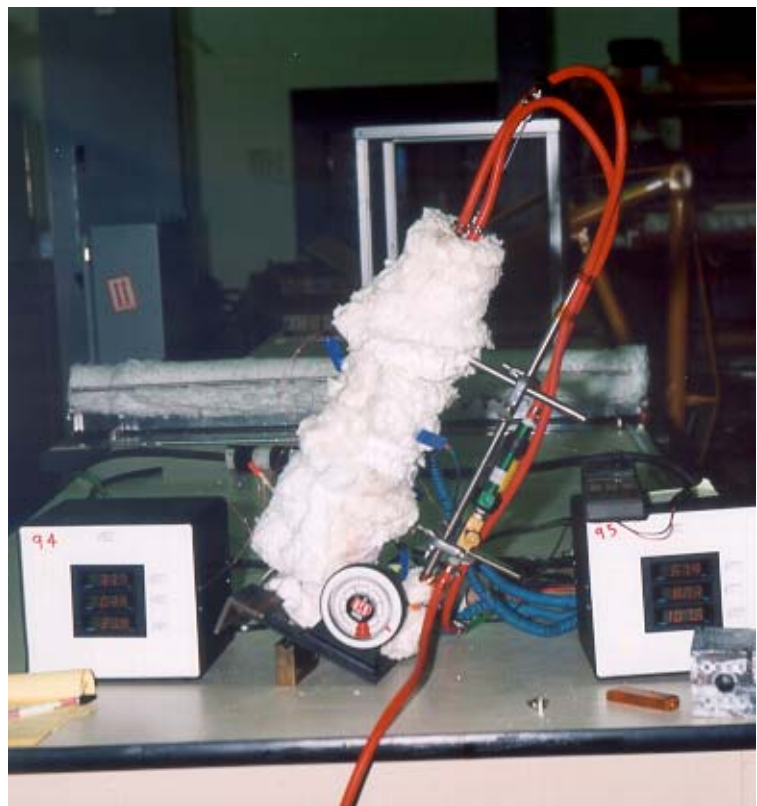
Additional heat pipes more representative of BAC geometry were built and tested to determine an empirical value for thermal resistance of the heat pipe in BAC operation. Figure C5 shows the heat pipe being readied for testing. Figure C6 shows it under test. Figure C7 is a graph of the measured thermal resistance. The overall thermal resistance fell between 0.070 and 0.073 °C/W. This is slightly higher than the 0.06°C/W that is listed in Table 1 of the main report.



**Figure C4. Delta-T performance of Life Test Heat Pipes (For 1750 hours of “high temperature” testing)**

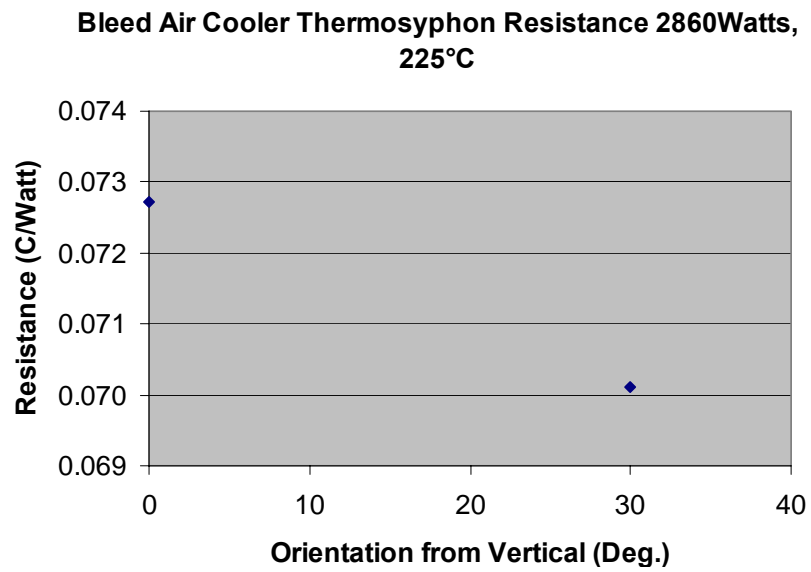


**Figure C5. Un-insulated HP**



**Figure C6. Heat Pipe under Test**  
 Fixture tilted for non-vertical operation.





**Figure C7. Measured Thermal Resistance of Heat Pipe**

## **Appendix A-D**

### **EWI Welding and Engineering Support Report**

# REPORT

April 1, 2005

Navy ManTech Program Project No. R0644

EWI Project No. 46255GDE Task 5

Contract No. N00014-02-C-0106

## Welding Engineering Support for Advanced High Temperature Heat-Pipe Heat Exchanger Prototype Fabrication

by

Christopher C. Conrardy, James L. Reynolds, Brian Lu, and Nancy C. Porter



Prepared for:

Naval Surface Warfare Center  
Philadelphia, PA



Navy ManTech Program Project No.R0644  
Project No. 46255GDE Task 5  
Contract No. N00014-02-C-0106

**Welding Engineering Support for Advanced High Temperature Heat-Pipe Heat Exchanger  
Prototype Fabrication**

by

Christopher C. Conrardy, James L. Reynolds, Brian Lu, and Nancy C. Porter

Prepared for:

**Naval Surface Warfare Center  
Philadelphia, PA**

April 1, 2005

**EWI  
1250 Arthur E. Adams Drive  
Columbus, OH 43221**

## **Abstract**

During the production of a bleed air cooler (BAC) heat exchanger prototype, inadequate tube-to-sheet weld quality due to poor joint access and excessive weld distortion, and inadequate brazing quality were investigated. Using a consumable insert gas tungsten arc welding (GTAW) process, a micro torch, a balanced welding sequence, and a strong-back fixture, mock-up samples were successfully produced within the flatness requirement of +/- 0.015-inches with acceptable weld quality. Voids were typical in the fin-to-tube braze joints that were evaluated. Fin legs must contain a true 90° bend in order to provide a proper joint gap and adequate joint length, or the result is increased void formation. Porosity was also found in the welds adjacent to braze joints indicating an interaction between brazing and welding.

# Contents

	<u>Page</u>
<b>Abstract .....</b>	<b>i</b>
<b>List of Figures .....</b>	<b>iii</b>
<b>Acknowledgements .....</b>	<b>iv</b>
<b>Legal Notice.....</b>	<b>iv</b>
<b>1. Summary.....</b>	<b>5</b>
<b>2. Introduction .....</b>	<b>5</b>
<b>3. Methods, Assumptions, and Procedures .....</b>	<b>6</b>
3.1 Tube-to-Sheet Welding .....	6
3.2 Tube-Sheet Distortion Control .....	11
3.3 Braze Joint Evaluation.....	13
3.4 Cost Reduction Strategies.....	14
<b>4. Results and Discussion .....</b>	<b>14</b>
4.1 Tube-to-Sheet Weld Quality .....	14
4.2 Tube-Sheet Distortion Control .....	18
4.3 Braze Joint Evaluation.....	18
4.4 Cost Reduction Strategies.....	21
4.4.1 Automated Orbital GTAW .....	21
4.4.2 Laser Welding.....	21
4.4.3 All-Brazed Assembly.....	21
4.4.4 Automated Lathe Welding .....	22
4.4.5 Thermionic Cleaning.....	22
4.4.6 Eliminate Post-Weld Machining .....	22
4.4.7 Split Tube-Sheet Design .....	23
<b>5. Conclusions .....</b>	<b>23</b>
<b>6. Recommendations.....</b>	<b>24</b>
6.1 Tube-Sheet Welding.....	24
6.2 Cost Reduction Strategies.....	24
6.3 Brazing .....	24
<b>7. References.....</b>	<b>25</b>
<b>8. Acronyms .....</b>	<b>26</b>
<b>9. Distribution List .....</b>	<b>27</b>
<b>Appendix A - Consumable Insert Welding Procedure.....</b>	<b>1</b>
<b>Appendix B - Thermionic Cleaning Summary Report SR0412 .....</b>	<b>1</b>

## List of Figures

	<u>Page</u>
Figure 1 - Prototype BAC Design.....	7
Figure 2 - BAC Assembly.....	8
Figure 3 - BAC Assembly Step 1 .....	8
Figure 4 - BAC Assembly Step 2 .....	9
Figure 5 - BAC Assembly Step 3 .....	9
Figure 6 - Weldcraft Micro TIG Torches.....	10
Figure 7 - Weldcraft MT-125 45° Torch .....	10
Figure 8 - ACT's Custom GTAW Torch Holder .....	10
Figure 9 - Mock-Up Sample at ACT.....	11
Figure 10 - Recommended Welding Sequence to Minimize Distortion.....	12
Figure 11 - ACT Strong-Back Fixture.....	13
Figure 12 - Five Evaluated Brazed Assemblies .....	14
Figure 13 - Sketch of Suggested Cut Line .....	14
Figure 14 - Suggested Cut Line on Mock-Up.....	14
Figure 15 - Cross-Section ACT Weld with Incomplete Penetration .....	15
Figure 16 - ACT Consumable Insert Weld with Melt-Back.....	16
Figure 17 - EWI Consumable Insert Weld Profile .....	16
Figure 18 - Cross Section of EWI Consumable Insert Weld .....	17
Figure 19 - Distortion Displacements on ACT Mock-Up .....	18
Figure 20 - Braze Assembly #1 Macro.....	19
Figure 21 - Braze Assembly #2 Macro.....	19
Figure 22 - Braze Assembly #3 Macro.....	19
Figure 23 - Braze Assembly #4 Macro.....	19
Figure 24 - Braze Assembly #5 Macro.....	19
Figure 25 - Assembly #1 Braze Joint Voids with Bowed Fin Leg.....	20
Figure 26 - Assembly #2 Braze Joint Voids with Bowed Fin Leg.....	20
Figure 27 - Assembly #3 Braze Joint Voids with Porosity in Adjacent Weld.....	20
Figure 28 - Assembly #4 Braze Joint Voids with Porosity in Adjacent Weld.....	20
Figure 29 - Assembly #5 Braze Joint Voids with Porosity in Adjacent Weld.....	20
Figure 30 - Thermionically Cleaned Tube-Sheet Joint.....	22
Figure 31 - Split Tube-Sheet Design Concept .....	23

## **Acknowledgements**

This report was prepared by Nancy C. Porter, Edison Welding Institute, as an account of work on Project No. 46255GDE Task 5, under Contract to the Navy Joining Center of Excellence. Funding for this work was provided by the United States Navy's Manufacturing Technology (ManTech) Program under contract N00014-02-C-0106 with Edison Welding Institute.

## **Legal Notice**

The United States Navy, Department of Defense, Navy Joining Center, nor Edison Welding Institute, nor its subcontractors, nor any of their employees, makes any warranty, express or implied, or assumes any legal liability or responsibility for the accuracy, completeness, or usefulness of any information, apparatus, product or processes disclosed in this report, or represents that its use would not infringe privately owned rights. Reference herein to any specific commercial product, process, or service by trade name, trademark, manufacturer, or otherwise, does not necessarily constitute or imply its endorsement, recommendation, or favoring by the United States Government or any agency thereof. The views and opinions of authors expressed herein do not necessarily state or reflect those of the United States Government or any agency thereof.



## 1. Summary

During the production of a bleed air cooler (BAC) heat exchanger prototype, inadequate tube-to-sheet weld quality due to poor joint access and excessive weld distortion were investigated.

Manual cold wire feed gas tungsten arc welding (GTAW) procedure with a micro GTAW torch was used to produce mock-up samples that were subsequently cross-sectioned to determine weld quality. Manual GTAW with a consumable insert ring was then used to produce welded mock-up samples in approximately half the time with increased weld quality.

A welding sequence was designed to balance heat input about the neutral axis of the tube-sheet assembly. With the welding sequence, a mock-up sample was welded without restraint to determine unrestrained distortion displacements. The resultant weldment was flat within +/- 0.010-inches, which was well within the flatness requirements of +/- 0.015-inches.

As a final risk-reduction measure for the last mock-up sample, an extra 0.12-inches of thickness was left on the tube-sheet flange area, so a post weld machining operation could be performed to achieve the flange flatness requirements. Using the recommended welding sequence, this mock-up sample was welded in a strong back fixture designed to restrain bowing of the tube-sheet during welding. The resultant weldment was well within the specified flatness requirements and the material stock added for a post weld machining operation was ultimately unnecessary.

Voids were typical in the fin-to-tube braze joints that were evaluated. Fin legs must contain a true 90° bend in order to provide a proper joint gap and adequate joint length, or the result is increased void formation. Porosity was also found in the welds adjacent to braze joints indicating an interaction between brazing and welding.

There are many potential cost savings opportunities for the heat pipe BAC units. Automating the tube-sheet joining process with orbital welding equipment would reduce operator skill requirements while improving weld quality and productivity. Welding process candidates for an automated orbital system are GTAW or laser welding (both with a consumable insert ring). The entire tube-sheet assembly could alternately be furnace brazed. Tube end caps could be welded with a lathe system. Thermionic cleaning could be used to increase productivity of cleaning operations and subsequent welding operations. A fabricated, split tube-sheet design also offers potential weight and material cost savings opportunities that should be evaluated.

## 2. Introduction

The Carderock Division of the Naval Surface Warfare Division, Ship Systems Engineering Station (NSWC-SSES), has developed a design for an improved gas turbine Bleed Air Cooler (BAC) heat exchanger to reduce excessive maintenance costs and improve reliability relative to the existing design (Figure 1). The new design offers significant environmental advantages, since it reduces the need for chemical cleaning of waterside heat exchanger precipitates produced when seawater is

heated above 150°F. If successful, the improved BAC may be used on both existing and future turbine powered surface ships.

The heat exchanger design includes a tube bundle comprised of 195 closely spaced, finned 70/30 copper-nickel alloy heat pipes that penetrate a 70/30 copper-nickel tube-sheet. The design includes both brazed and arc-welded joints. 0.835-in. diameter 1/4-in. wall tubes are arc welded into a 1-3/8-inch thick tube-sheet. The design calls for tube-to-sheet fillet welds to be produced on both sides of the tube-sheet. Fins are then brazed on the tubes on both the seawater and airsides of the tube-sheet. The heat-pipes extend 3- to 5-inches above the tube-sheet and are spaced about 7/8-inches apart.

During the course of the project, a prototype heat pipe BAC heat exchanger was constructed as a proof-of-concept (see Figure 2 through Figure 5). The prototype is in the process of being installed in a DDG class ship for field testing later this year. Thermacore (a division of Modine) had primary responsibility for constructing the tube bundle. Advanced Cooling Technologies (ACT) performed the tube bundle welding. The tube bundle was then shipped to Weigmann-Rose (in Oakland, CA) for assembly into the shell.

### **3. Methods, Assumptions, and Procedures**

Since only one prototype is being fabricated for field testing, NSWC asked EWI to help minimize risk in the joining

processes. In the initial project meeting, EWI identified the following potential risks:

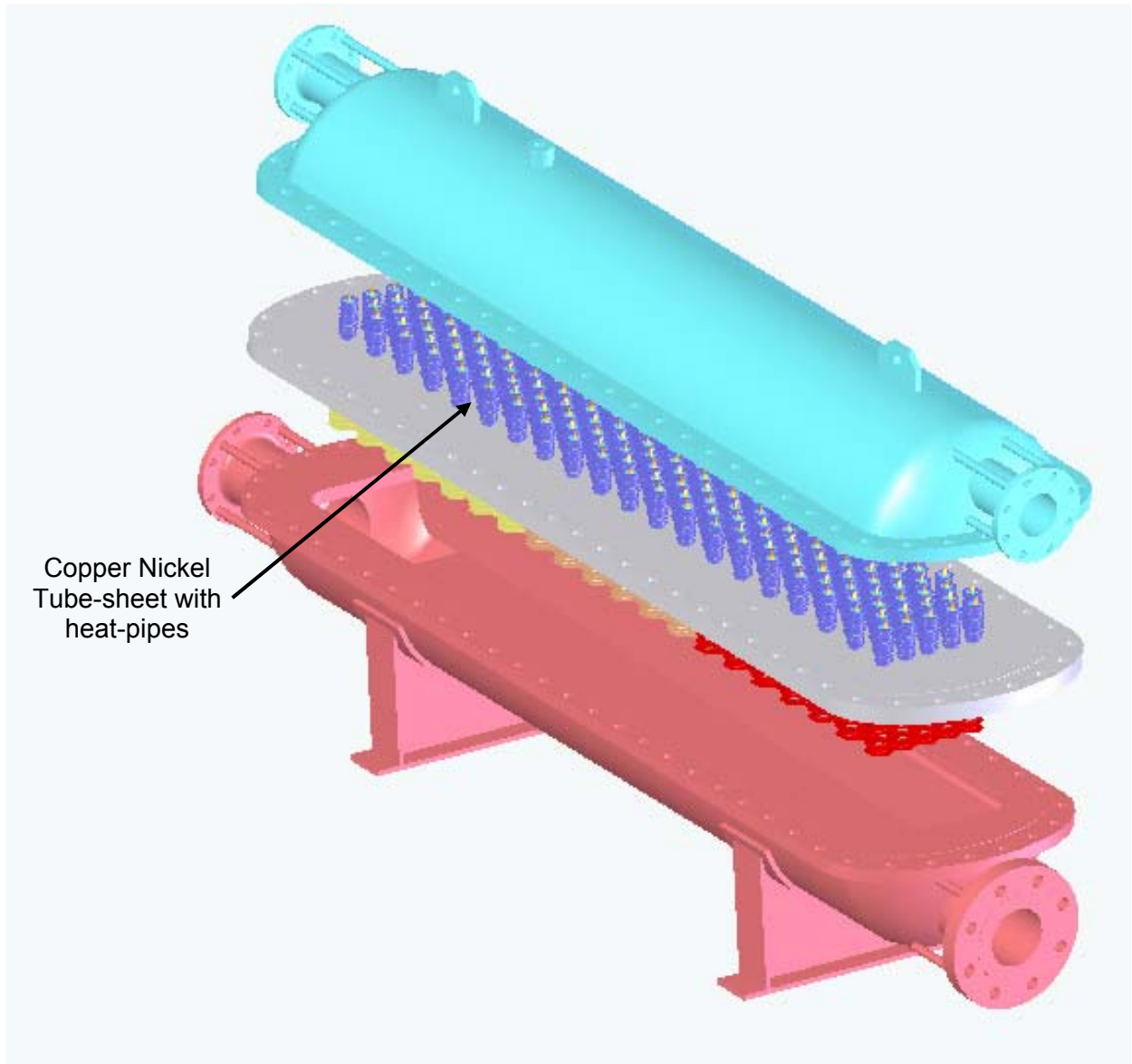
- Inadequate tube-to-sheet weld quality due to poor joint access
- Excessive distortion of the tube-sheet as a consequence of welding heat-input
- Inadequate braze quality

This section describes the methods, assumptions, and procedures used in this investigation.

#### **3.1 Tube-to-Sheet Welding**

Manual gas tungsten arc welding (GTAW) was used to produce the sample tube-to-sheet welds for this investigation. ACT conducted weld trials with manual cold-wire feed GTAW. EWI and ACT then conducted weld trials using a consumable insert ring with the GTAW process.

The largest risk with the manual GTAW approach was the poor access caused by the close proximity of the tubes. The restricted access reduced the visibility of the joint and the welder's ability to maintain the proper arc length and work angle relative to the joint. To improve weld quality, a specialized GTAW torch was used to allow acceptable work angles to be achieved despite limited joint access. The full line of Weldcraft micro GTAW torches shown in Figure 6 were evaluated by the team.



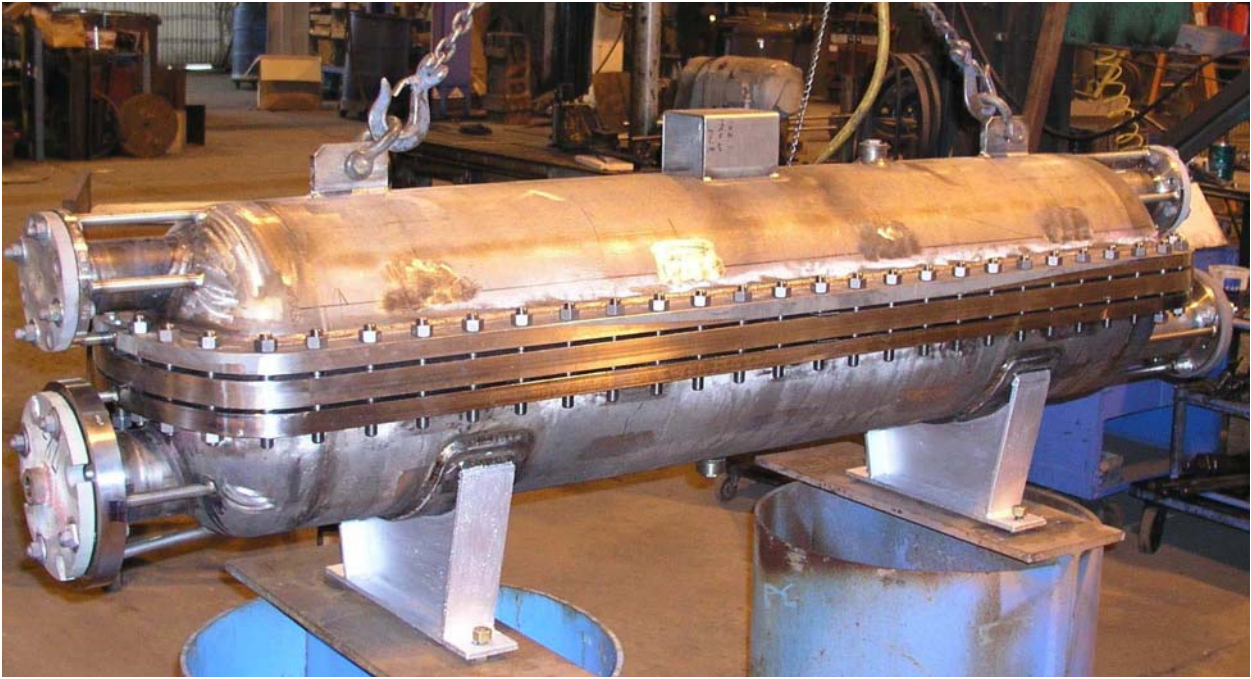
**Figure 1 - Prototype BAC Design**



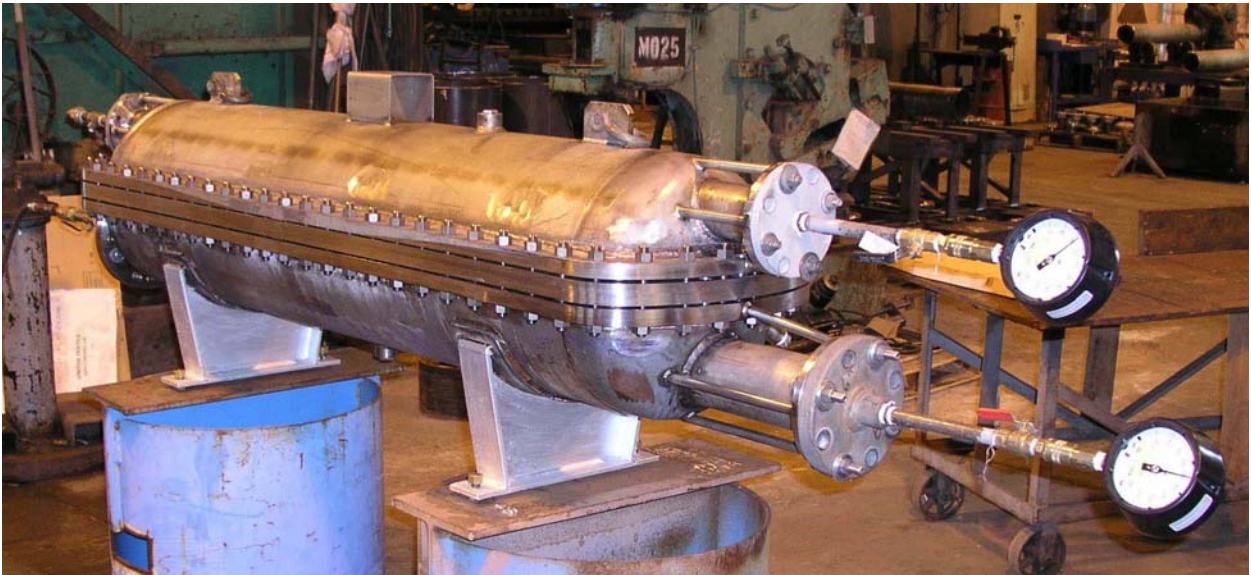
**Figure 2 - BAC Assembly**



**Figure 3 - BAC Assembly Step 1**



**Figure 4 - BAC Assembly Step 2**



**Figure 5 - BAC Assembly Step 3**



**Figure 6 - Weldcraft Micro TIG Torches**

EWI selected the water-cooled, MT-125 torch, which features a 45° Pyrex cup with an electrode chuck (Figure 7). This torch model was used by both EWI and ACT and in tube-sheet welding sample fabrication.



**Figure 7 - Weldcraft MT-125 45° Torch**

For welding trials conducted at ACT, ACT developed a custom tool to hold the torch (Figure 8) as it was moved around the tube. ACT used this tool to produce sample welds; EWI

manipulated the torch manually to produce sample welds.

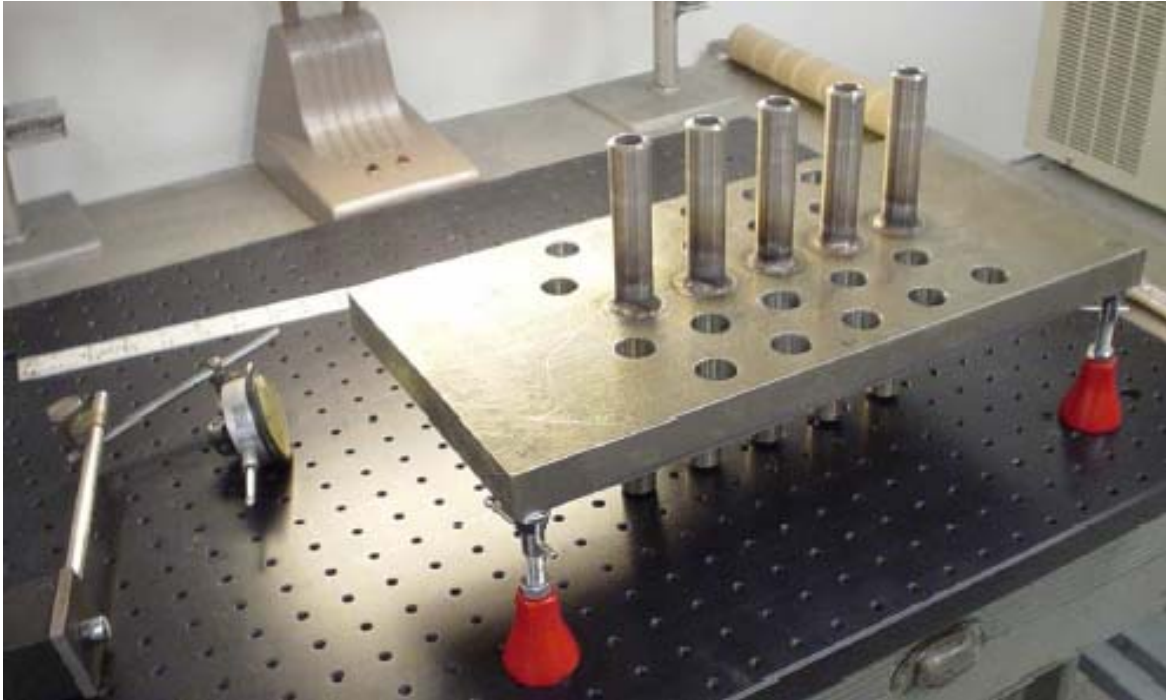


**Figure 8 - ACT's Custom GTAW Torch Holder**

To reduce welding-related risks, mock-up samples were produced to develop and validate the welding procedures. Both EWI and ACT performed welding trails using the mock-up sample design shown in Figure 9 that was machined from extra tube-sheet material.

For the first round of weld trials (without a consumable insert), ACT used an autogenous (*i.e.*, no filler metal) preheat pass, followed by manual cold-wire feed GTAW to deposit the weld metal in order to achieve the minimum required weld size.

For all welding trials conducted at EWI, EWI used a Thermal Arc 160GTS GTAW power supply with pulsing capabilities.



**Figure 9 - Mock-Up Sample at ACT**

#### EWI Welding Parameters

- 75He/25Ar shielding gas using a flow rate of 60 CFH
  - 1 sec. preflow, 10 sec. postflow
- 0.0625-in diameter, 2% Ceriated tungsten, 40° included angle and 0.05-in blunted point
- No preheat
- 25A initial current
- Pulsing parameters
  - 160A peak/80A background current
  - 50/50 balanced square wave form
  - 1 Hz pulse frequency

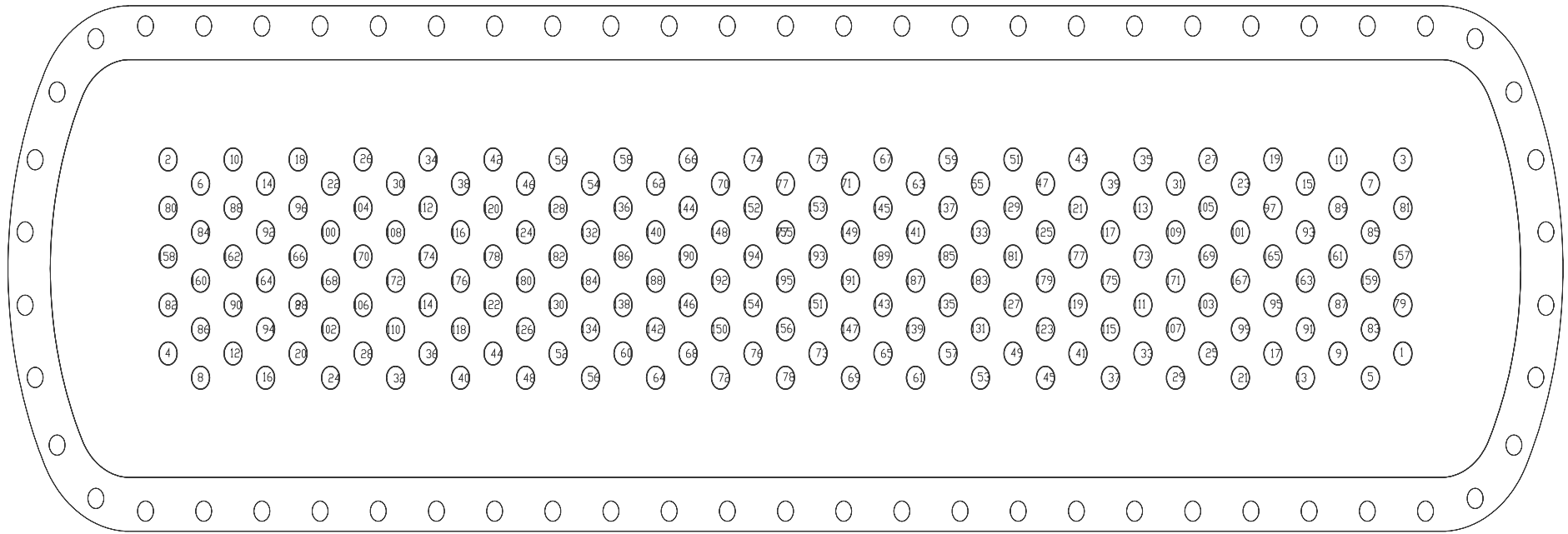
The complete welding procedure used by EWI is located in Appendix A.

Both EWI and ACT used a CI-0.835 ID, IN67 0.125-in round wire consumable insert for tests with consumable insert welding.

#### **3.2 Tube-Sheet Distortion Control**

To ensure a leak-tight seal, the tube-sheet bolting flange must be flat to within +/- 0.015-inches. Shrinkage stresses induced from arc welding can cause the tube-sheet to distort. The following steps were taken to minimize the risk of failing dimensional requirements:

**Weld Sequencing.** A welding sequence was used to minimize out-of-plane distortion by balancing the heat input about the neutral axis of the part. Figure 10 illustrates the welding recommended sequence. Four tube fillet welds are to be produced on one side of the tube-sheet, then the tube-sheet is flipped and the same tubes are welded on the other side. The welding sequence starts at opposite corners and works around the periphery and then toward the center.



**Figure 10 - Recommended Welding Sequence to Minimize Distortion**



**Fixturing.** Strong-back tooling was used to restrain bowing of the tube-sheet during welding. ACT designed and built the fixture in Figure 11. The frame of the fixture was built from deep

section C-channels to provide good rigidity. Trunions were incorporated into the fixture so that the tube-sheet could be easily flipped for weld sequencing.



**Figure 11 - ACT Strong-Back Fixture**

**Heat-Input Control.** An important consideration in controlling distortion is maintaining consistency in weld size and welding heat-input. Test mock-ups were welded to allow the welder to develop the procedure and to practice maintaining consistent heat-input.

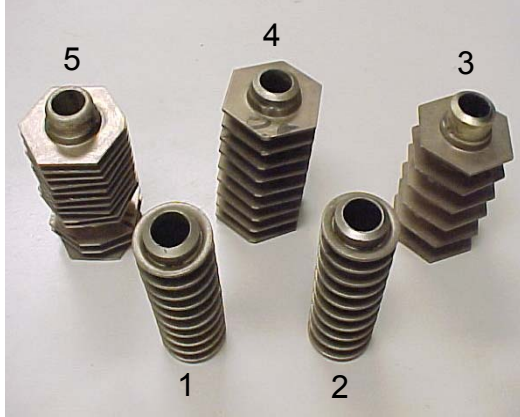
**Extra Stock.** As a final risk-reduction measure, an extra 0.12-inch of material thickness was left on the tube-sheet flange area, so a post weld machining operation could be performed to achieve the flange flatness requirements.

### 3.3 Braze Joint Evaluation

After manual GTA welding of the tubes to the tube-sheet, heat-transfer fins are manually assembled on the tubes. Furnace brazing is used to bond the fins to the tubes. ACT and Thermacore had previously selected a brazing alloy and worked with a vendor to develop a procedure. EWI was asked to provide on-going assistance with the brazing operations.

Ten brazed fin-to-tube assemblies were provided to EWI. The fins were manually assembled to the tubes, and

then furnace brazed with a Braze 604 wire ring perform (supplied by Lucas-Milhaupt). As shown in Figure 12, EWI selected five brazed fin-to-tube assemblies of various pitch lengths for metallographic examinations.



**Figure 12 - Five Evaluated Brazed Assemblies**

The Figure 12 assemblies were cross-sectioned into quarters that were visually examined for voids. Selected sections containing voids were further sectioned and mounted for microscopic evaluation.

**3.4 Cost Reduction Strategies**

NSWC indicated that a target cost for production heat-pipe BAC units is \$50K or less, which will require substantial fabrication productivity increases and/or material savings as compared with the prototype unit. NSWC asked EWI to comment on potential opportunities for cost savings.

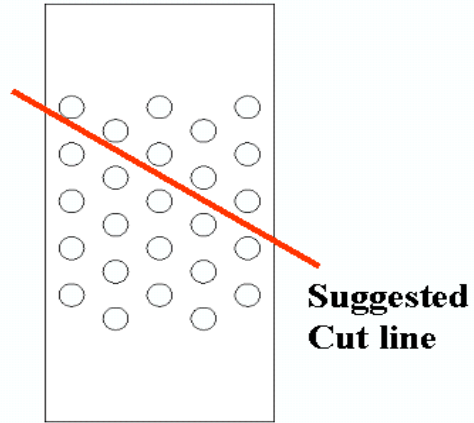
**4. Results and Discussion**

The following section is a discussion of the results of this investigation.

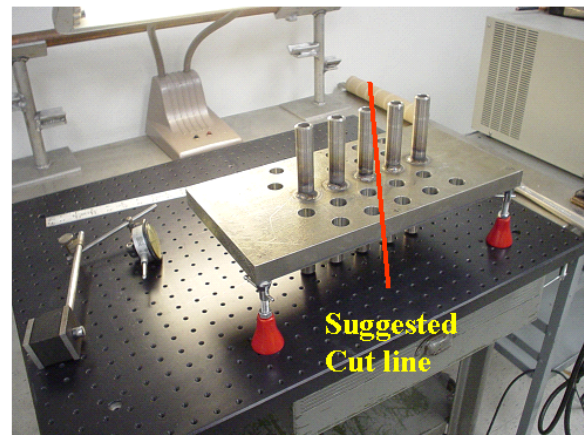
**4.1 Tube-to-Sheet Weld Quality**

To verify the weld quality of mock-up samples (Figure 9), EWI performed metallographic evaluation of the

specimens. In Figure 13, the EWI suggested cross sectional cut line is illustrated on a sketch of a full mock-up sample. Figure 14 shows the cross-sectional cut line on an actual mock-up sample.



**Figure 13 - Suggested Cut Line Sketch**



**Figure 14 - Suggested Cut Line on Mock-Up**

Figure 15 shows a representative weld cross-section of a typical ACT weld made with an autogenous preheat pass, followed by manual cold-wire feed GTAW weld.

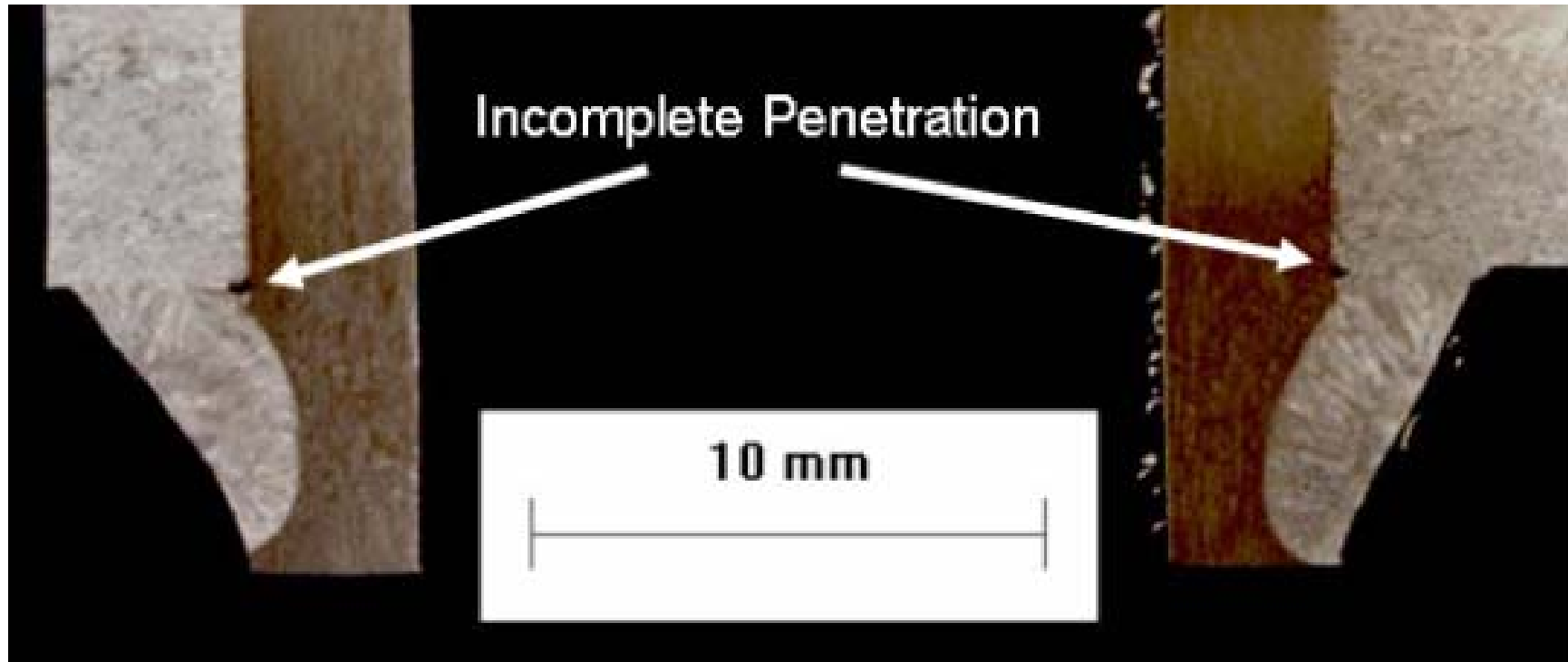


Figure 15 - Cross-Section ACT Weld with Incomplete Penetration

These ACT welds had good profiles, met the minimum weld size requirement, and were free of gross defects. The only issue observed was inconsistent weld root penetration, as indicated in Figure 15. Most of the cross-sectioned welds had incomplete root penetration. Incomplete root penetration is generally not acceptable for fillet welding applications<sup>1</sup>, but for tube-sheet applications, the primary concern is minimum weld throat<sup>2</sup>. Incomplete root penetration should not be a significant concern unless fatigue is a major consideration.

To achieve greater weld consistency and productivity as compared to the cold wire GTAW procedure used by ACT, EWI selected a CI-0.835 ID, IN67 0.125-in round wire consumable insert which is of sufficient size to produce a 1/16-inch fillet weld,. Both ACT and EWI performed welding trials to evaluate the insert welding option.

ACT experienced difficulty using the inserts. As Figure 16 shows, the ACT procedure resulted in poor wetting (*i.e.*, melt-back) of the insert.

Using the procedure in Appendix A, EWI produced welds with excellent profiles (Figure 17).

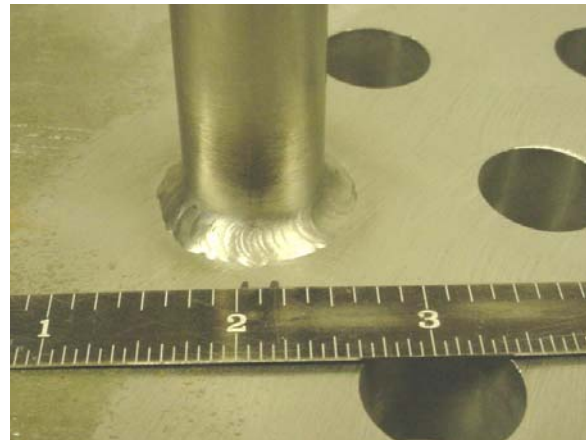
<sup>1</sup> MIL-STD-248, *Welding and Brazing Procedure and Performance Qualification* (Washington: Naval Sea Systems Command, 1997), Section 5.4.2.2.

<sup>2</sup> MIL-STD-248, *Welding and Brazing Procedure and Performance Qualification* (Washington: Naval Sea Systems Command, 1997), Section 4.5.2.6.



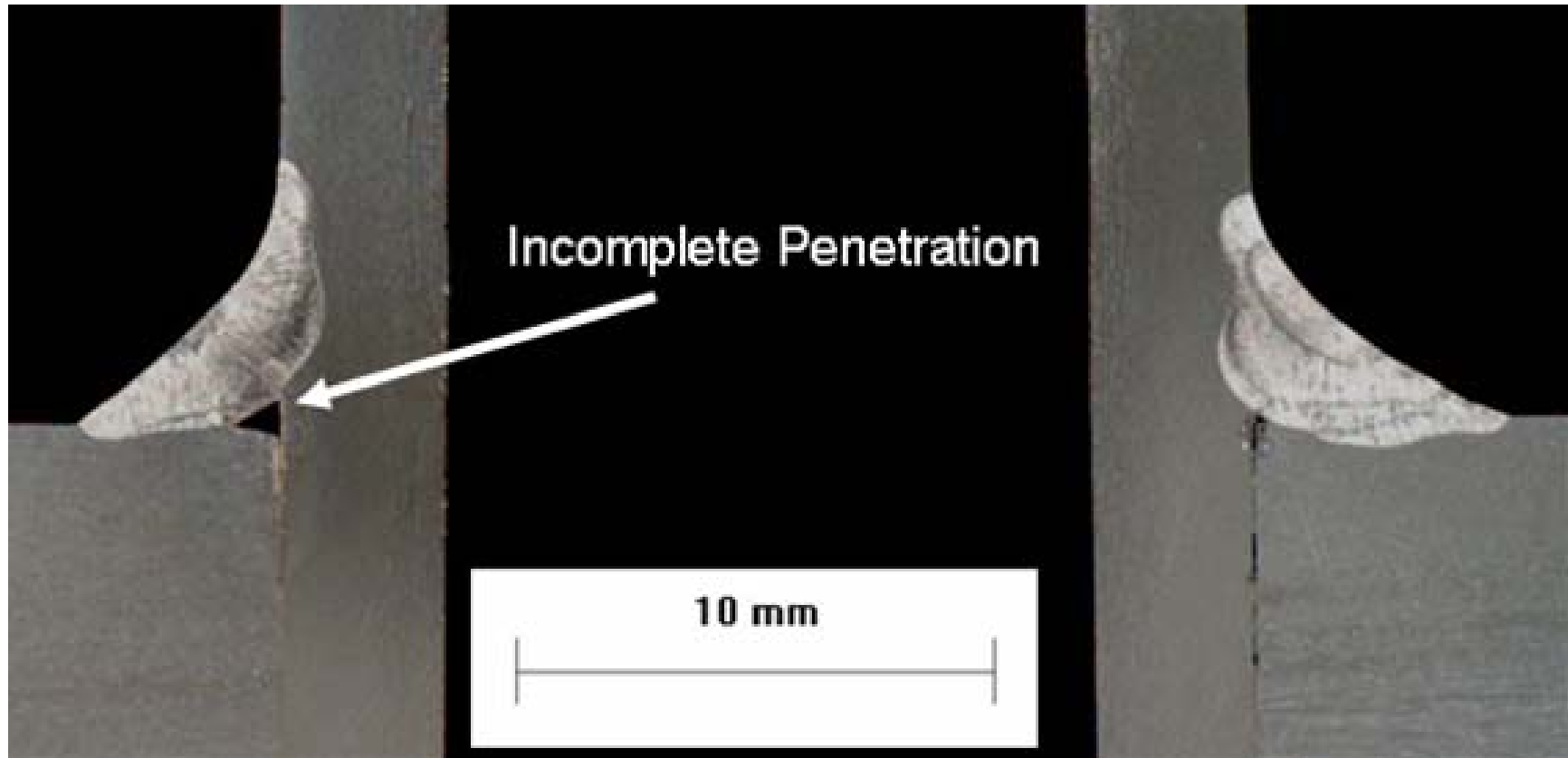
**Figure 16 - ACT Consumable Insert Weld with Melt-Back**

Unlike the ACT procedure, the EWI procedure did not use a preheat pass. While this procedure enabled the use of consumable inserts, it did not solve the incomplete root penetration issue, as shown in Figure 18.



**Figure 17 - EWI Consumable Insert Weld Profile**

Optimization of the consumable insert design and welding procedure is necessary to consistently achieve complete penetration. As is discussed in section 4.4, this would be best achieved with automated orbital GTAW.



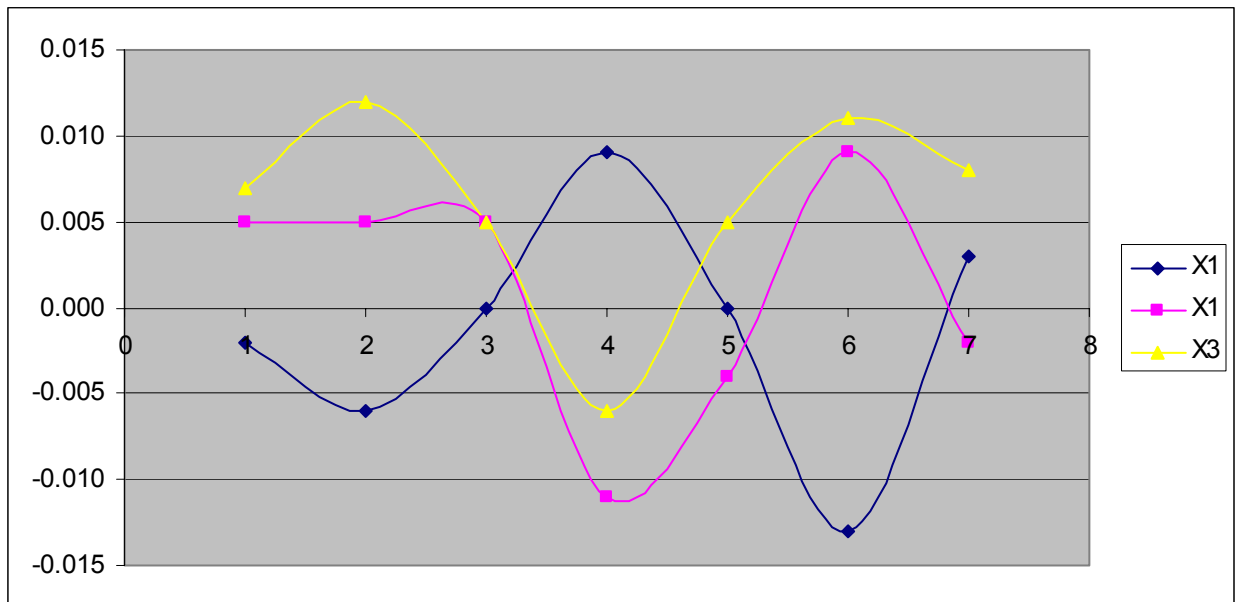
**Figure 18 - Cross Section of EWJ Consumable Insert Weld**

## 4.2 Tube-Sheet Distortion Control

To ensure a leak-tight seal, the tube-sheet bolting flange must be flat to within  $\pm 0.015$ -inches. Shrinkage stresses induced from arc welding can cause the tube-sheet to distort. The distortion remediation steps outlined in section 3 were implemented and produced a mock-up that met the dimensional requirements.

Mock-up welding trials provided insight into the expected magnitude of the out-

of-plane distortion. Figure 19 shows distortion measurements that were recorded by ACT during welding of an unrestrained mock-up sample. Three points were measured with a dial indicator as each weld was produced. The change in out-of-plane displacement was less than 0.010-inches for each point. Based on these results, the distortion of the restrained (*i.e.*, fixtured) prototype tube-sheet was expected to be well within the target range.



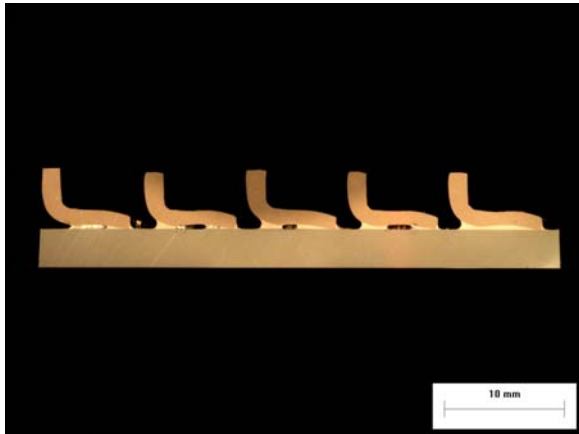
**Figure 19 - Distortion Displacements on ACT Mock-Up**

The extra stock of 0.12-inches that was left on last prototype's tube-sheet flange area was, in retrospect, found to be unnecessary. The other distortion reduction measures were sufficient to maintain flatness within the requirements, thus eliminating the need for a final machining operation. Cost savings could be achieved by eliminating the post-weld machining

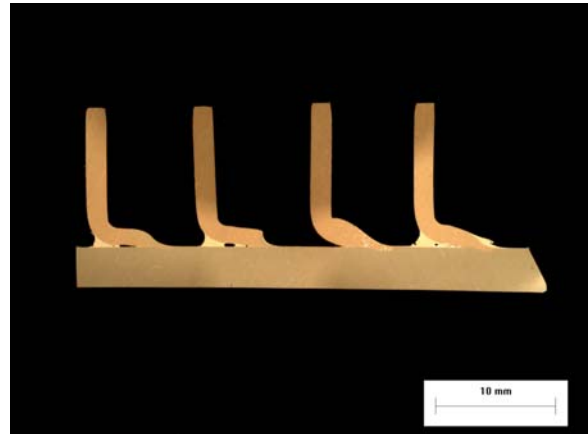
operation on subsequent fabrications, as is discussed in section 4.4.

## 4.3 Braze Joint Evaluation

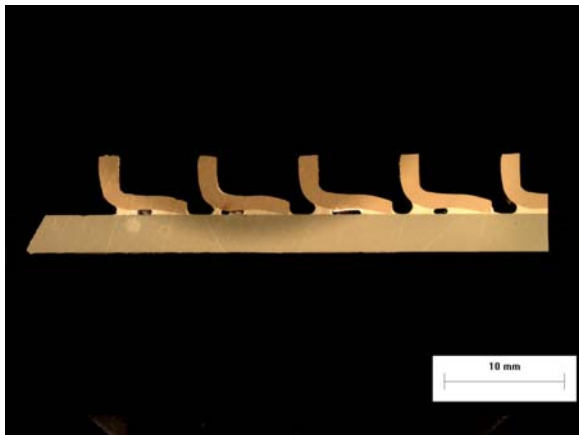
EWI selected five brazed fin-to-tube assemblies of various pitch lengths for metallographic examinations. Figure 12 shows the five assemblies as received. Figure 20 through Figure 24 are macros of the five cross-sectioned brazed assemblies.



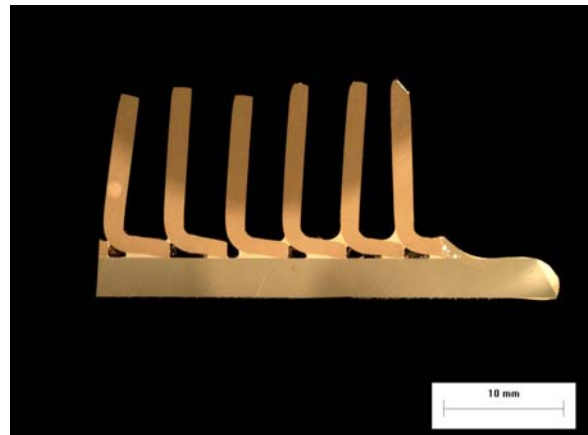
**Figure 20 - Braze Assembly #1 Macro**



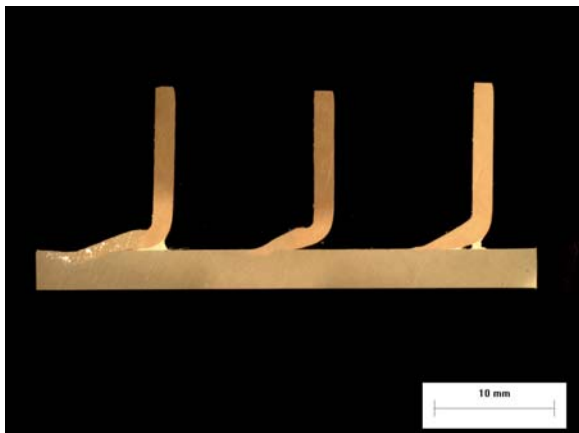
**Figure 23 - Braze Assembly #4 Macro**



**Figure 21 - Braze Assembly #2 Macro**



**Figure 24 - Braze Assembly #5 Macro**

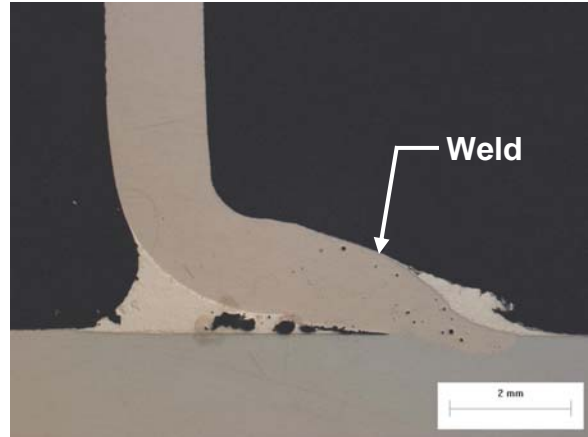


**Figure 22 - Braze Assembly #3 Macro**

Selected sections with voids were further sectioned, mounted in bakelite, and polished. The micrographs in Figure 25 through Figure 29 were taken from these polished samples.



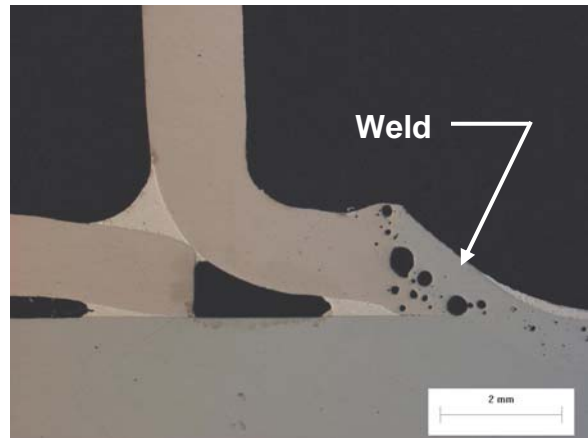
**Figure 25 - Assembly #1 Braze Joint Voids with Bowed Fin Leg**



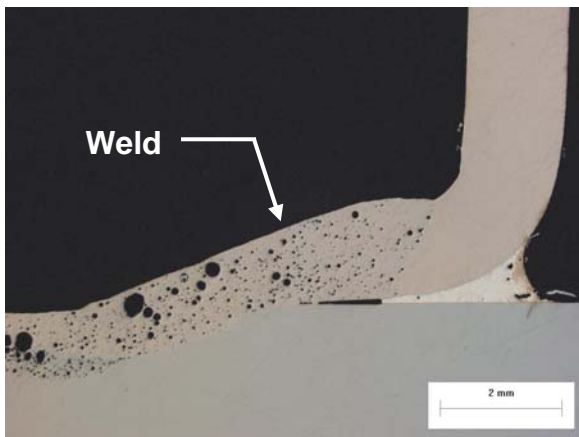
**Figure 28 - Assembly #4 Braze Joint Voids with Porosity in Adjacent Weld**



**Figure 26 - Assembly #2 Braze Joint Voids with Bowed Fin Leg**



**Figure 29 - Assembly #5 Braze Joint Voids with Porosity in Adjacent Weld**



**Figure 27 - Assembly #3 Braze Joint Voids with Porosity in Adjacent Weld**

The results indicate that the brazed fin-to-tube assemblies have moderate braze quality. Voids were found in all five of the examined assemblies.

Figure 25 and Figure 26 are the micrographs of brazed joint assemblies #1 and #2. The likely cause of voids in these joints is the bowed shape of the fin legs. Bowed legs create a joint gap too large to retain the liquid alloy during brazing, thus causing voids or incomplete fill. The legs should be straight to provide a uniform joint gap prior to brazing. The voids may also be



caused by the degree of bending of the fin legs and/or the interaction between brazing and welding.

Some joints contained very little braze alloy, *e.g.*, assembly #3 (Figure 22) and #4 (Figure 23) and the second joint to the left in assembly #5 (Figure 24). A common characteristic of these joints is that the fin legs do not have a 90° bend and that they form a large angle with the center tube. This results in very little overlap between the leg and the tube (*i.e.*, inadequate joint length). An ideal fin leg would have a 90° bend that would allow adequate joint length. There may also be a welding interaction effect, which might have caused the shape of the legs to change prior to brazing. Since the pre- and post-weld fin measurements are not available, this cause cannot be quantified.

In addition to voids in the brazed joints, porosity was observed in the welds adjacent to the braze joints (Figure 27 through Figure 29). Although the sequence of welding and brazing is not known, it is obvious that there is some degree of interaction between brazing and welding that resulted in porosity.

#### **4.4 Cost Reduction Strategies**

NSWC indicated that a target cost for production heat-pipe BAC units is \$50K or less, which will require substantial fabrication productivity increases and/or material savings as compared with the prototype unit. Following is a discussion of the potential cost savings opportunities.

##### **4.4.1 Automated Orbital GTAW**

Manual GTAW is by its nature slow and inconsistent. Automating this process with orbital welding equipment would

reduce operator skill requirements while improving weld quality and productivity. Automated orbital GTAW is a common technique for tube-to-sheet welding. Restricted access caused by the close proximity of the tubes would necessitate development of a custom orbital head. The consumable insert welding procedure (Appendix A) and the mechanical torch holder (Figure 8) would provide good starting points for developing orbital welding techniques suitable for the heat-pipe BAC.

##### **4.4.2 Laser Welding**

The limited access between tubes is a major challenge for arc welding the tube-to-sheet joints. Laser welding may provide a flexible and more-productive alternative to orbital GTAW. A long focal point fiber laser and a means of manipulating the laser beam (*e.g.*, either an orbital head or an articulated-arm robot) would be required. Consumable insert rings would provide the filler metal. Testing would be necessary to determine whether laser welding is a viable alternative and to develop the necessary equipment and procedures.

The large capital investment required for a laser implementation may be a barrier to this approach.

##### **4.4.3 All-Brazed Assembly**

GTAW fillet welding is a time-consuming process. Brazing should be considered as a possible alternative tube-to-sheet joining method. Since the fins are already furnace brazed, the tubes could also be brazed without an additional operation. The main barrier to an all-brazed assembly is the Navy's reluctance to permit brazing for copper-nickel heat exchangers, due to past problems with corrosion of the braze

material leading to leaks. Because the tube-sheet is so thick, there is little chance that corrosion would result in leaking; therefore, brazing may be viable for the heat-pipe BAC tube-sheet. To implement an all-brazed design, an appropriate brazing procedure (furnace atmosphere and thermal-cycle) must be developed to accommodate the large differences in thickness between the tube-sheet, tubes, and fins. A suitable repair procedure would also be needed in case some furnace braze joints fail to meet leak requirements. Finally, corrosion testing should be performed to verify the performance of the all-brazed design.

#### 4.4.4 Automated Lathe Welding

Welding of the tube end caps could be readily automated with lathe welding equipment. Programmable GTAW lathe welders automatically coordinate process parameters, wire feed, tube rotation, and control arc length. Implementation of commercially available equipment would reduce operator skill requirements while improving weld quality and productivity.

#### 4.4.5 Thermionic Cleaning

Cleanliness is critical to ensure weld consistency and braze joint quality. Thermionic cleaning is a recently developed technology that employs a low power electric arc to remove oxides and contaminants from the metal surface. A recent EWI internal research program<sup>3</sup> found significant improvement in copper-nickel weld quality (and consistency of penetration) when

<sup>3</sup> J. Reynolds, B. Green, M. Boring, S. Manring, G. Ritter, D. Holdren, and C. Conrardy, "Thermionic Cleaning Applications", EWI Report, Project No. 47421GTO (2004).

thermionic cleaning was employed. A simple thermionic cleaning trial was performed to demonstrate the process on a heat-pipe tube-sheet mock-up. Figure 30 shows an area that was cleaned in a few seconds. The surface oxides were removed, leaving a white etched appearance. This technique shows merit and should be evaluated for the heat-pipe BAC tube-sheet application to improve weld/braze quality and to reduce cleaning labor.



**Figure 30 - Thermionically Cleaned Tube-Sheet Joint**

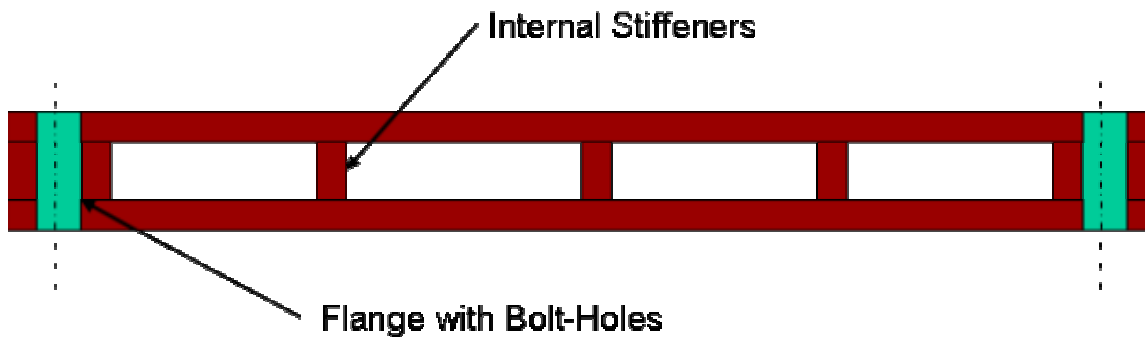
#### 4.4.6 Eliminate Post-Weld Machining

As previously discussed, extra stock was left on the tube-sheet flange area to allow a post-weld machining operation to be performed to achieve flatness requirements. During the prototype construction, it was found that the application of welding distortion control techniques could result in a sufficiently flat tube-sheet without post-weld machining. A significant cost-avoidance could be accrued by eliminating the post-weld machining operation, provided production welding techniques are sufficiently refined and controlled.

#### 4.4.7 Split Tube-Sheet Design

The thick copper-nickel tube-sheet is a major contributor to the material cost and weight of the heat-pipe BAC. A fabricated design may allow a significant reduction in tube-sheet material, without sacrificing performance. The schematic of Figure 31 illustrates the concept. Internal stiffeners (perhaps furnace

brazed) may provide sufficient rigidity at much less weight. This design would also allow a leaking tube-sheet weld to be instantly detected by an integrated pressure sensor. A study should be performed to compare the benefits of a split tube-sheet design against the extra costs required to fabricate the tube-sheet.



**Figure 31 - Split Tube-Sheet Design Concept**

### 5. Conclusions

Using a consumable insert GTAW process, a balanced welding sequence, and a strong-back fixture, mock-up samples were successfully produced within the flatness requirement of  $\pm 0.015$ -inches. Using these procedures, the resultant prototype did not need the additional 0.12-inch of material thickness that was left on the tube-sheet flange for a post weld machining operation to bring the assembly within flatness requirements.

There are many potential cost savings opportunities for the heat pipe BAC units. Automating the tube-sheet joining process with orbital welding equipment would reduce operator skill requirements while improving weld

quality and productivity. Welding process candidates for an automated orbital system are GTAW or laser welding (both with a consumable insert ring). The entire tube-sheet assembly could alternately be furnace brazed. Tube end caps could also be welded using a lathe system. Thermionic cleaning could also be used to increase productivity of cleaning operations. A fabricated, split tube-sheet design also offers potential weight and material cost savings opportunities.

Voids were typical in the fin-to-tube braze joints. The shape of fin legs is an important factor affecting the formation of voids. Porosity was found in the welds adjacent to the braze joints. Although the detailed procedures are not known, interaction between brazing and welding is apparent.

## 6. Recommendations

### 6.1 Tube-Sheet Welding

For the tube-sheet welding operations, EWI recommends the following welding process suggestions to increase productivity by more consistently producing weldments with a first time quality level that meet flatness requirements and have higher quality welds.

A micro GTAW welding torch such as the Weldcraft MT-125 torch (Figure 7) should be used to allow the welder to gain necessary access to the weld joint given the limited access inherent to the tube-sheet design. Greater access to the weld joint will result in fewer weld defects.

GTAW welding with a consumable insert such as the CI-0.835 ID, IN67 0.125-inch round wire insert should be considered as an alternative to manual cold wire feed GTAW to improve weld consistency and productivity. Additional optimization of the consumable insert design and welding procedure is necessary to consistently achieve complete penetration. Consumable insert welding would also be beneficial to the eventual mechanization of the welding process preferably with automated orbital GTAW.

Tube-sheet welding should be performed with a carefully designed welding sequence such as that presented in section "3.2 *Tube-Sheet Distortion Control*", as it is critical to balance heat input about the neutral axis of the weldment in order to reduce welding distortion.

Tube-sheet welding should be performed in a strong back fixture of sufficient mass to restrain the assembly during welding. The fixture should also be designed such that it easy flips the welded assembly over to allow the welder to adhere to the requisite welding sequence.

The application of the aforementioned welding distortion control techniques can result in a sufficiently flat tube-sheet without the need for post-weld machining. A significant cost-avoidance could be achieved by eliminating the post-weld machining operation, provided production welding techniques are sufficiently refined and controlled.

### 6.2 Cost Reduction Strategies

Following are potential savings opportunities that should be investigated prior to developing a production plan:

- Automated orbital GTAW welding with a consumable insert ring
- Laser welding with consumable insert ring
- Brazing tube-to-sheet joints
- Automated lathe welding of tube end caps
- Thermionic cleaning
- Implementing a split tube-sheet design

### 6.3 Brazing

To obtain a strong braze joint with minimum voids, the fin legs should have a 90° bend at the end section to form a proper joint gap and to provide adequate joint length. Proper welding procedures are also necessary to avoid porosity in the welds adjacent to the brazed joints.

## 7. References

J. Reynolds, B. Green, M. Boring, S. Manring, G. Ritter, D. Holdren, and C. Conrardy, "Thermionic Cleaning Applications", EWI Report, Project No. 47421GTO (2004).

MIL-STD-248D, *Welding and Brazing Procedure and Performance Qualification* (Washington: Naval Sea Systems Command, 1997), Replacement Document NAVSEA Technical Publication S9074-AQ-GIB-010/248.

## 8. Acronyms

<b>Acronym</b>	<b>Definition</b>
ACT	Advanced Cooling Technologies
BAC	Bleed Air Cooler
EWI	Edison Welding Institute
GTAW	Gas Tungsten Arc Welding
NJC	Navy Joining Center
NSWC	Naval Surface Warfare Center
SSES	Ship Systems Engineering Station
TIG	Tungsten Inert Gas (a.k.a. GTAW)

## 9. Distribution List

Denis Colahan  
Naval Surface Warfare Center  
1000 Kitty Hawk Avenue  
Philadelphia, PA 19112  
Email: colahandj@nswccd.navy.mil

Chris Conrardy  
Edison Welding Institute  
1250 Arthur E. Adams Drive  
Columbus, OH 43221

Harvey Castner  
Edison Welding Institute  
1250 Arthur E. Adams Drive  
Columbus, OH 43221

Tim Trapp  
Edison Welding Institute  
1250 Arthur E. Adams Drive  
Columbus, OH 43221

Nancy Porter  
Edison Welding Institute  
1250 Arthur E. Adams Drive  
Columbus, OH 43221

Dr. Anne Marie T. SuPrise  
Best Manufacturing Practices Center  
4321 Hartwick Rd., Suite 400  
College Park, MD 20740

**Appendix A - Consumable Insert Welding Procedure  
Welding Procedure for Welding 70Cu/30Ni  
Tube to Sheet using Consumable Insert<sup>4</sup>**

**Cleaning**

Tube-sheet

1. Remove machining layout dye using acetone wipe
2. Remove surface oxide using silicon carbide flap sander or equivalent method
3. Wipe with isopropanol immediately prior to welding.

Tube

1. Remove surface oxide using ScotchBrite abrasive pad or equivalent method
2. Wipe with isopropanol immediately prior to welding.

Consumable Insert

1. Remove surface oxide using ScotchBrite abrasive pad or equivalent method
2. Wipe with isopropanol immediately prior to welding.

**Welding**

Consumables

- CI-0.835 ID, IN67 0.125-in round wire consumable insert.

Equipment

- Thermal Arc 160GTS GTAW or equivalent power supply with pulsing capabilities
- Weldcraft MT-125 water cooled GTAW torch using a 45° Pyrex cup and electrode chuck

Welding Parameters

- Welds conducted manually with or without manipulation fixture
- 75He/25Ar shielding gas using a flow rate of 60CFH
  - 1 sec. preflow, 10 sec. postflow.
- 0.0625-in diameter, 2% Ceriated tungsten, 40° included angle and 0 0.05-in blunted point.
- No preheat
- 25A initial current
- Pulsing parameters
  - 160A peak/80A background current
  - 50/50 balanced square wave form
  - 1 Hz pulse frequency

---

<sup>4</sup> Written by Jim Reynolds, Applications Engineer, EWI. Date: August 25, 2004



## Appendix B - Thermionic Cleaning Summary Report SR0412

# CRP

Cooperative  
Research  
Program

Summary  
Report  
SR0412

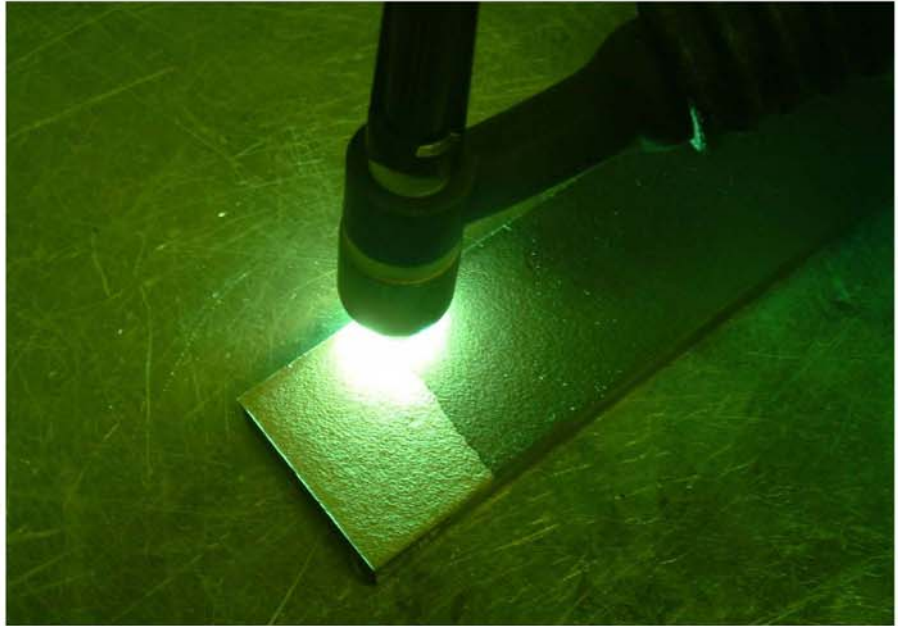
July 2004

(47421IRP)

Jim Reynolds  
Bruce Green  
Matt Boring  
Steve Manring  
George Ritter  
Dick Holdren  
Chris Conrardy

**EWI**

## Thermionic Cleaning Applications



### Abstract

Thermionic cleaning is an emerging cleaning technology that employs an electrical arc to remove surface contaminants. Thermionic cleaning is believed to offer an environmentally friendly alternative to conventional chemical or mechanical cleaning techniques. The objectives of this work were to investigate the effectiveness of thermionic cleaning for a variety of applications and to establish a procedural specification for the process. The process was tested for removal of oxides from stainless steel, titanium, copper-nickel, aluminum, and copper alloys. It was also evaluated for removal of residual penetration enhancing compounds, carbon deposits, and preconstruction primer. Thermionic cleaning was found to be an effective surface cleaning technique on a variety of geometries, including plate, pipe, and wire. Additional work is warranted to optimize the process and investigate the technical and financial merits of thermionic cleaning for specific industrial applications.

### 1.0 Introduction

Surface cleaning is often necessary to remove organic, inorganic, and oxide contaminants from metal surfaces prior to welding or bonding. Conventional cleaning methods often employ chemical agents to remove surface contaminants. While effective, chemical cleaning has become problematic due to increased scrutiny by environmental regulatory agencies, as well as health and safety regulators. Mechanical surface cleaning is an alternative to chemical cleaning, but mechanical cleaning is often labor intensive and inconsistent.

**EWI**

## Appendix B - Thermionic Cleaning Summary Report SR0412

Thermionic cleaning is an emerging cleaning technology that is believed to offer an environmentally friendly alternative to existing conventional techniques. Thermionic cleaning employs an electric arc to remove surface contaminants without the use of chemical agents of any kind. In its most basic form, thermionic cleaning is simply the utilization of a direct-current-electrode-positive (DCEP) gas tungsten arc welding (GTAW) arc to remove surface oxides from conductive materials without melting of the base materials. The exact mechanism by which the cleaning occurs is not well understood, although several theories have been proposed. While the technique was patented nearly 20 years ago, it has not yet been widely applied. Work is needed to evaluate the effectiveness of thermionic cleaning for a variety of applications.

### 2.0 Objectives

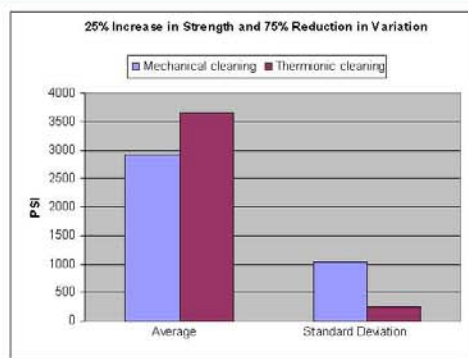
The objectives of this work were to investigate the effectiveness of thermionic cleaning for a variety of applications and to establish a procedural specification for the process.

### 3.0 Scope and Findings

Thermionic cleaning was evaluated on a range of applications. A recommended thermionic cleaning procedure document was also developed to aid in standardization of the cleaning process. The following is a brief summary of the principle findings of this work.

#### Pre-weld Cleaning of Stainless Steel Pipe

Thermionic cleaning was evaluated as a potential method to increase welding speed by improving joint cleanliness. Partial penetration autogenous GTAW welds were produced on 2-in. diameter Schedule 40, Type 304 stainless steel pipe in the as-received and thermionically cleaned conditions. It was found that defect-free welds can be produced 20% faster on thermionically cleaned samples as compared with the as-received samples.



**Tensile Strength of Adhesive Bonded Copper Lap Joints**

**EWI**

#### Removal of Penetration Enhancing Compounds

Penetration enhancing compounds (PEC's) are used to provide a significant increase in weld penetration with the GTAW process. By increasing penetration, PEC's can improve productivity and reduce distortion. A by-product of utilizing the compounds is a surface remnant that detracts from the weld appearance. Thermionic cleaning was explored as a method for removal of residual surface compounds that result from the use of PEC's. Thermionic cleaning was found to be an efficient method for removal of residual PEC's.

#### Cleaning of Copper for Adhesive Bonding

Copper and its alloys present adhesive bonding problems because surface oxides form readily and have low tenacity. While adhesive bonds can be formed, their longevity is suspect, especially in humid environments. Finding effective surface preparation methods is therefore important for adhesive bonding of copper.

The effect of thermionic cleaning on the bond strength of copper lap joints was evaluated. 1/8-in. thick alloy 110 copper sheet samples were evaluated using abrasive cleaning only, thermionic cleaning, and abrasive cleaning with subsequent AC Tech AC130 sol-gel pretreatment. Tensile testing was performed to compare the bond strength achieved with each preparation method. Samples were evaluated in both dry and wet environments utilizing a humidity chamber to simulate a specific level of humidity. Thermionic cleaning was found to improve the tensile test performance compared to mechanical cleaning alone. Thermionic cleaning produced similar results as the combination of abrasive cleaning and sol-gel pretreatment. Surface tension measurement testing showed that thermionic cleaning nearly doubled the material surface tension with respect to the as-received material.

#### Pre-weld Cleaning of Titanium Structural T-joints

The effectiveness of thermionic cleaning for pre-cleaning of structural weld joints was evaluated. Cleanliness is critical in obtaining optimal weld properties of titanium alloys. Cleaning with conventional methods is usually conducted prior to joint fitting because cleaning is difficult to perform effectively after assembly. Thermionic cleaning was investigated as a means to allow cleaning of joints after fitting. Titanium in the as-received condition with an intact mill oxide was evaluated. The joint configuration consisted of a T-joint with a blind corner, which is difficult to effectively clean with mechanical methods. Thermionic cleaning effectively removed mill oxide from the root of the joint.

#### Pre-weld Cleaning of Titanium and Aluminum Pipe

The effectiveness of thermionic cleaning for reduction of porosity in aluminum pipe (4-in. Schedule 40 alloy 6061) and titanium tube (2-in. diameter, 0.10 in. wall CP-Grade 2)

## Appendix B - Thermionic Cleaning Summary Report SR0412



**Ti Alloy T-Joint with Blind Corner Cleaned with Thermionic Cleaning**

welds was assessed. Aluminum and titanium welds were produced utilizing materials in the as-received, mechanically cleaned, and thermionically cleaned conditions. In addition, chemically clean aluminum was evaluated. Welds were evaluated with radiography using ASME Section IX acceptance criteria.

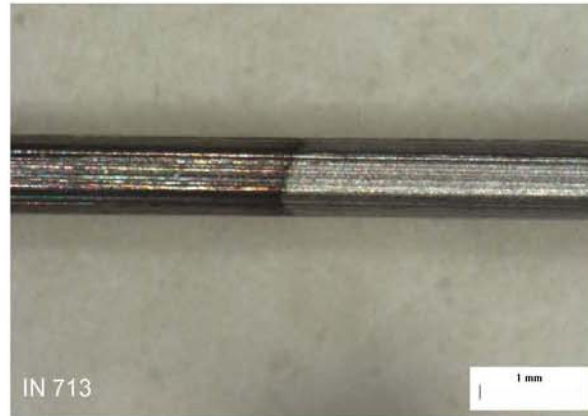
The welds made on material in the as-received condition contained significant porosity that rendered the welds unacceptable. Welds utilizing mechanical cleaning exhibited acceptable levels of porosity. Likewise, chemical cleaning displayed acceptable amounts of porosity. Thermionic cleaning displayed the least amount of porosity, with no visible indications of porosity using conventional X-ray radiography.

### Pre-weld Cleaning of Copper-Nickel Pipe

This task evaluated the effects of thermionic cleaning on weld penetration for Cu-Ni alloys. Cu-Ni alloy pipes are widely used in marine applications for both commercial and military vessels. These pipes typically have relatively thin wall thickness and can be difficult to clean utilizing abrasive cleaning methods without violating the minimal wall thickness limitations. Welds were produced on 2-in. diameter, Schedule 5, 70%Cu-30%Ni alloy pipe in the as-received condition and in the thermionically cleaned condition. Thermionically cleaned samples showed significantly improved weld penetration and bead profile consistency as compared with as-received samples.

### Cleaning of Titanium and Nickel-Based Filler Wires

Weld wire cleanliness is often difficult to maintain and is a frequent source of weld contamination. Often, filler wire must be maintained in inert atmospheres to avoid excessive oxidation. The development of a non-invasive wire cleaning technique could provide improved wire cleanliness and provide a significant cost savings due to defect avoidance. A



**Thermionically Cleaned IN713 Weld Wire**

feasibility study was conducted to determine if the concept of thermionic wire cleaning was practicable. A prototype thermionic cleaning apparatus was developed for in-line cleaning of the welding wire during welding. The apparatus was designed to be affixed between the wire spool and the wire feeder for cleaning of the wire during welding. The concept was successfully demonstrated with microscopic examination of nickel-based alloy 713 and titanium alloy Ti-6-4 welding wire samples before and after thermionic cleaning.

### Removal of Carbon Deposits

Carbon deposits are often removed from gas turbine engine combustion components utilizing aggressive chemical cleaning processes that can attack the substrate. Thermionic cleaning was evaluated as a potential alternative method for the removal of carbon deposits. It was found that carbon deposits were readily removed from the surface of gas turbine engine fuel injector assemblies using thermionic cleaning with no apparent erosion of the base metal.



**Gas Turbine Engine Fuel Nozzles**

## Appendix B - Thermionic Cleaning Summary Report SR0412

### Removal of Preconstruction Primer from Steel Plate

Primers are often applied to structural steels as a final processing step to prevent corrosion after blasting. Many of the primers currently used are considered to be “weldable” primers, meaning acceptable welds can be produced without removal of the primer. In practice, welding over primer can produce porosity, particularly if the primer thickness and welding parameters are not closely controlled. The only method to assure that porosity is avoided is to remove the primer prior to welding. Conventional primer removal methods include mechanized sanding, grinding, or abrasive blasting. Thermionic cleaning was evaluated as an alternative method for removing primer from steel plate prior to welding. Thermionic cleaning was shown to remove the primer with minimal residue remaining on the surface. This result suggests that an automatic thermionic cleaning apparatus could potentially be used to clean weld joints prior to welding to improve weld quality.

### Thermionic Cleaning Procedure Document

A recommended thermionic cleaning procedure document was developed to aid in standardization of the cleaning process. The recommended cleaning specification for thermionic cleaning is provided in Appendix A of the full report.

### 4.0 Conclusions

Thermionic cleaning was found to be a viable alternative to chemical or mechanical cleaning methods for a number of general applications. Additional work is warranted to optimize the process and investigate the technical and financial merits of thermionic cleaning for specific industrial applications.

CONVERSIONS			
Angle, Plane	Force	Length	Temperature
deg=0.01745 rad	lb force=4.448 N	in=25.4 mm	$T_K = t_c + 273.15$
Density	kg force=9.807 N	ft=304.8 mm	$t_c = (t_f - 32) / 1.8$ , $t_f = 1.8t_c + 32$
lb mass/in <sup>3</sup> =27679.9 kg/m <sup>3</sup>	1000 lb force=1 kip=4.448 kN	Mass	Travel / Wire Feed Speed
lb mass/ft <sup>3</sup> =16.02 kg/m <sup>3</sup>	Fracture Toughness	lb <sub>m</sub> =0.4536 kg	in/min=0.4233 mm/s
Deposition Rate	ksi in <sup>1/2</sup> =1.0986 MN m <sup>-3/2</sup>	Power Density	ft/min=5.08 mm/s
lb/h=0.4536 kg/h	N mm <sup>-3/2</sup> =0.029 ksi in <sup>1/2</sup>	W/in <sup>2</sup> =1550 W/m <sup>2</sup>	ft/min=18.288 m/h
Energy	Heat Input	Pressure (Gas and Liquid)	Volume
calorie=4.184 J	J/in=39.37 J/m	psi=6.895 kPa	in <sup>3</sup> =16387 mm <sup>3</sup>
kW hour=3.6 × 10 <sup>6</sup> J	kJ/in=39.37 kJ/m	psi=0.06896 bar	ft <sup>3</sup> =0.02832 m <sup>3</sup>
Flow Rate	kJ/mm=25.4 kJ/in	Stress	
ft <sup>3</sup> /h=0.4719 L/min	Impact Energy	ksi=6.895 MPa	
ft <sup>3</sup> /min=28.32 L/min	ft/lb=1.356 J	N/mm <sup>2</sup> =1 MPa=145.0326 psi	
m <sup>3</sup> /h=35.311 ft <sup>3</sup> /h			

Contact Information Services at 614-688-5224 to obtain a full report on this project.

EWI is a world-class center dedicated to improving the competitiveness of industry through welding and other materials joining-related technologies. We work with member companies to find solutions to their materials joining challenges, helping them enhance productivity, product quality, and cost-effectiveness. Whether through consultation services to solve the day-to-day problems or confidential research projects to meet unique manufacturing needs, EWI is your complete resource for materials joining technology.

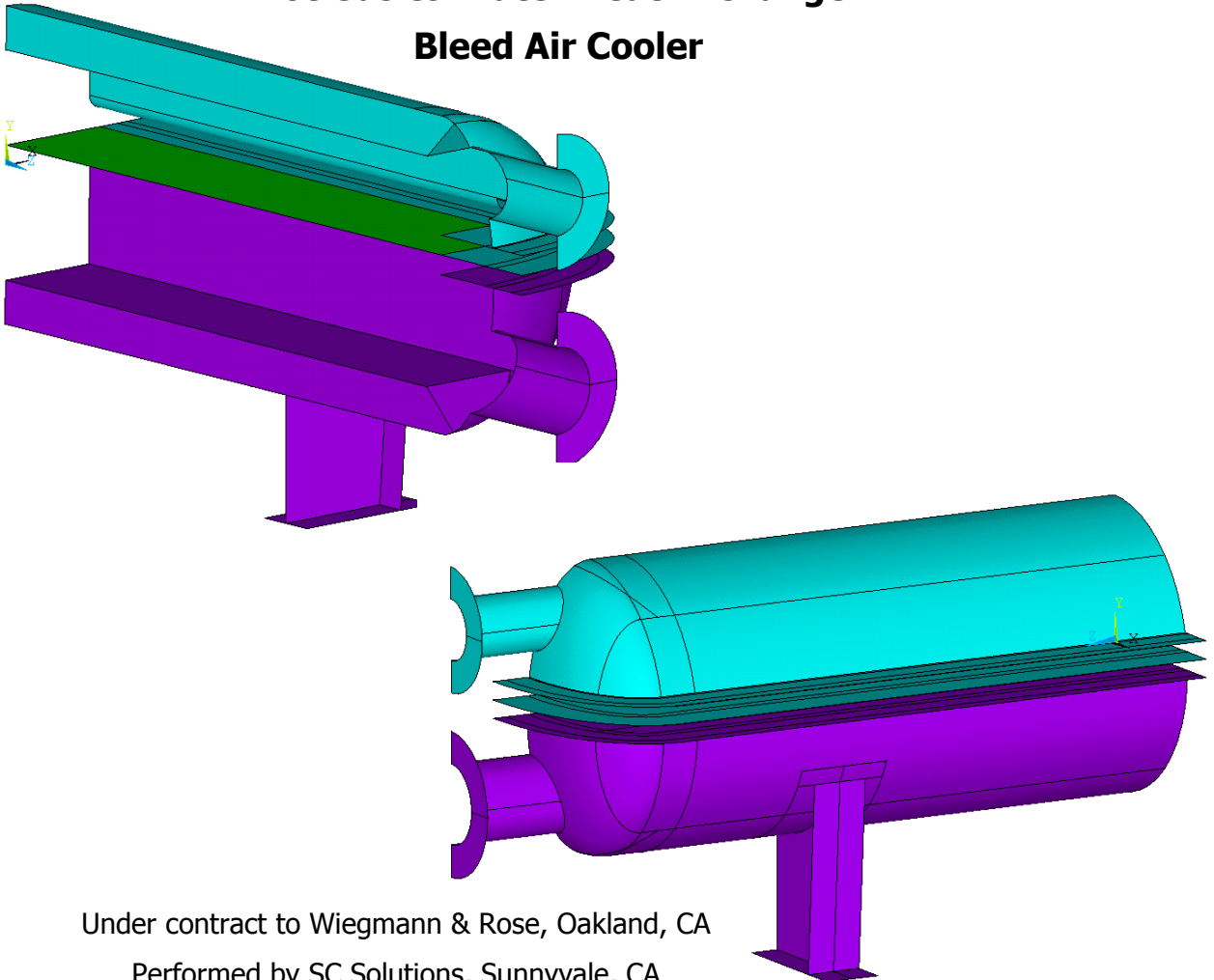


This report was prepared under contract with the State of Ohio with financial support from the Ohio Department of Development. The content reflects the views of EWI and does not necessarily reflect the views of the State of Ohio, Department of Development.



**Appendix A-E**  
**Structural Design Report**

**Structural Design Report for Prototype of  
Thermacore  
425 kW Mono-Height Heat Pipe  
Hot Gas to Water Heat Exchanger  
Bleed Air Cooler**



Under contract to Wiegmann & Rose, Oakland, CA

Performed by SC Solutions, Sunnyvale, CA

Contract No. N65540-03-C-0065



**SC SOLUTIONS**

This report documents the structural review of the prototype design of Thermacore's heat pipe bleed air cooler (BAC). The scope includes the top and bottom shells (with attached nozzles and supports) and the tube sheet to loads from gasket seating, pressure and a generalized temperature distribution. It does not include the heat tubes.

The design performance data for the cooler is shown in Table 1 of the Appendix A. The design has hot air of 925F, 100 psi flow through the bottom channel and 50 psi sea water through the top channel.

## Table of Contents

Summary	3		
Background	3		
Materials	3		
Approach	4		
Criteria	4		
Load Combinations	5		
Pressure Design		Thermal Design	
Loads		Thermal Analysis	16
Bolt up Loads	6	Results of Thermal Analysis	16
Pressure Loads	6	Response – Thermal	
Response – Limit stresses	7	Distortion	18
Membrane Stresses		Overall response	19
Shell	8	Membrane Stresses	20
Shell flange	8	Membrane plus Bending Stresses	
Membrane plus Bending Stresses		Tube Sheet	21
Shell	9	Shell flange	22
Shell flange	10	Bolt response	23
Tube Sheet	11		
Pressure Design Stress Summary	12		
Bolt response	13		
Gasket Pressure Distributions	14		
Baffles	24		
References	25		
Appendix A – Design Conditions	26		
Appendix B – Modeling Method	28		
Appendix C – Gasket and Bolting Calculation, Sizing	separate		

## Summary

This report indicates the prototype design for the bleed air cooler design will remain within ASME Sect VIII limits for strength.

The thermal loads will create local areas where either fatigue may limit the service life or excessive deformations at the flanges may require additional bolt tightening to assure gasket sealing when hot. This evaluation examines this with only a generalized thermal load. Refining evaluations related to thermal loads requires that a detailed thermal analysis be performed.

## Background

The objective of this report is to document the evaluation of a prototype cooler design. The evaluation includes the structural response of the components for gasket seating, pressurization and a temperature distribution loads. The criteria are based on the ASME Boiler & Pressure Vessel Code, Sect VIII Div.1. Most applicable in Div.1 are Part UHX for heat exchanger load combinations and Appendix 2 for gasket/ bolt interaction at flanges.

The 'split-shell' geometry deviates from the geometries covered in Div.1. Under U-2(g), the shell and flange of the cooler are evaluated to criteria of Sect VIII, Div.2, Appendix 4 (Design by Analysis) using stresses from finite element analyses (FEA).

The unique aspects of this configuration are the heat separation between halves of a cylinder, lengthwise, and the flange closure of the shell to achieve such a separation. The heat separation makes one half hot and the other half cold and introduces internal forces from restrained thermal growth. Orienting the flange as done produces two distinct response tendencies of the middle and ends.

## Materials

The cooler will be made of 70/30 Cu-Ni material for the tube sheet and top shell half. The bottom half will be made of 304SS and the bolting and gasket base will be Monel. Charts of the thermal and mechanic properties are included in Appendix C.

<u>Component</u>	<u>Material</u>	
Top Shell	70/30 Cu-Ni	
Tube Sheet	70/30 Cu-Ni	
Bottom Shell	304SS	
Bolts	Monel 400	5/8" diameter
Gaskets	Monel based Graphite coated	3/4" wide

The plate sizes used are listed below and represent minimums after forming or machining.

Shell & top heads	0.5"
Bottom heads	0.625"
Baffles	0.1875"
Shell flanges	1.0"
Tube sheet	1.375"
Water side nozzle	0.25"
Air side nozzle	0.12"

The assumption for material properties of the perforated area of the tube sheet follows the logic of ASME Sect VIII, Div2, Appendix 4-9, Stresses in Perforated Flat Plates where the elastic



modulus and Poisson's ratio vary as a function of pitch and ligament ratio and thickness. For the perforated area the effective elastic constant is set at 0.75x that off the 70/30 material.

### Approach

Three load types are present; bolt up, pressurizations and thermal. These are mentioned briefly below and in greater detail in later sections. The areas of interest are the flanges, shell, bolting and sealing.

The **bolt up** check is the response to the bolt preload necessary to seat the gasket. This varies considerably between the ends and middle, cylindrical locations as the middle is much more flexible than the ends. It establishes the base state to which pressure and thermal loads are added.

The **pressure loads** check the strength of the design and assures a basic structural integrity.

**Thermal loads** are created by temperature differences. The thermal membrane stresses are limited to assure progressive distortion will not occur. The local thermal bending stresses are generally considered only in fatigue analysis. For this prototype the number of thermal cycles is considered to be low and the local thermal bending stresses are not examined.

### Criteria

The criteria for evaluation of the cooler generally follows the rules of the ASME B&PV Code. The Code of record is ASME Sect VIII, Div.1, U stamp. Where Div.1 does not have formula or methods it allows 'proper engineering methods' in U-2(g). In this case the Design by Analysis rules in Appendix 4 of Sect VIII, Div2 serve as guidance for characterization of stresses and their limits. As shown below, the limit values are based on the type, source and location of stress.

where	load	stress	category
<b>From Sect VIII, Part UHX</b>			
Tube sheet	Pressure	Shear	
		Bending	1.5 S
	Pressure, thermal	Bending	3 S
<b>From Sect VIII, Div1, Appendix 3-350</b>			
Flange	pressure/ bolt up	membrane	S
		Bending	1.5 S
<b>From Sect VIII, Div2, Table 4-120.1</b>			
Junction of shell with flange	Pressure	Membrane	1.5 S
		Bending	3 S
Shell, over large area	Pressure/bolt up	Membrane	S
		Bending	1.5 S
<b>From Sect VIII, Div2, 4-120.1</b>			
Any area	thermal expansion	Membrane	3 S

ASME Sect VIII, Divs 1 and 2 have different allowable stresses with Div 2 generally being higher due to a lower margin of safety. As a measure of conservatism the Div1 allowable stresses

are used in the Div2 criteria. One result is that expressions for stress limits usually given in terms of  $S_m$  are denoted in terms of  $S$ .

Additionally, the allowable stress value will be taken for the design temperature, 300F for the top side and 925F for the bottom. This is 12.0 ksi for 70/30 and 10.7 ksi for the 304SS.

### Load combinations

The ASME criteria broadly breaks down to two load conditions, thermal and non-thermal. The non-thermal cases are bolt up, pressurizing of each side and pressure on both sides. The thermal cases simply add a temperature distribution to the non-thermal cases. The table below describes the load combinations examined and their pressure and thermal conditions. Following the table are the stress limits for specific areas of the design.

LC	Pressure			
	Air side	Water side	Thermal	
1	-	-	-	Bolt preload only
2	-	X	-	
3	X	X	-	
4	X	-	-	
5	X	-	X	Thermal cases
6	X	X	X	
7	-	X	X	
8	-	-	X	thermal only

The stress limits break out between those for thermal load cases (5-8) and non thermal load cases (1-4). The criteria are summarized below.

Location	stress type	non thermal LCs	thermal LCs
<b>Tube sheet</b>	bending	1.5 S	3 S
"	shear	0.8 S	0.8 S

For the bolted flanges, Div. 1, Appendix 2 will be used for defining gasket and bolting related loads.

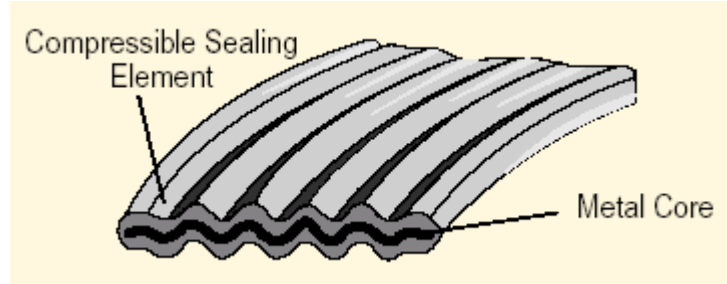
		preload	operating
<b>Bolting</b>	axial	S at ambient	S at temperature

The criteria of Div. 2, Appendix 4 is as follows.

Location	stress type	non thermal LCs	thermal LCs
<b>Shell, general</b>	membrane	1.0 S	3 S
"	memb + bending	1.5 S	-
<b>Shell at discontinuity</b>	membrane	1.5 S	3 S
"	memb + bending	3 S	-

## Bolt up Loads

The bolt up load represents the tightening of the bolts connecting the shell flanges to develop load to seat the gasket. The two halves of the cooler are sealed to the tube sheet by a set of gaskets, one on each side. Sixty-two bolts or studs clamp the edge flanges together. The gasket is a corrugated style with the basic components shown below.



Appendix C contains a hand calculation that follows the methodology of ASME Sect VIII, Div.1, Appendix 2 with modifications for a non-circular shape. It uses properties from a Garlock Corragraph, Style 601 gasket, 1/8" thick, 3/4" wide.

The calculation shows the bolt load necessary for gasket seating is 2620 lbs per bolt. The calculation also examines operating condition bolt loads and flange stresses for preliminary sizing.

In the FEA model the bolt preload is developed by specifying a prestrain in the bolt elements and observing the resulting tension load and iterating until all bolts are relatively close to the 2620 lb value. The amount of prestrain required is the sum of the strain to produce the bolt load plus the displacement of the flanges from that load. This quantity depends on the flexibility of the flange and varies between bolts along the sides and at the ends. Appendix B contains a table of bolts and their prestrains to achieve the 2620 lb load.

The analysis indicates bolt up loads dominate the shell stresses for the pressure load cases (which include bolt up).

## Pressure Loads

Pressure loads on each half are considering by 3 load cases, each side pressurized alone and one case with both sides pressurized. For the tube sheet the governing load case will be when the higher pressure side is acting alone. The hand calculation in Appendix C indicates the tube sheet to need to be between 1.25" and 1.375" thick. These same hand calculations indicate the general membrane stresses in the shell to be quite low, roughly 10% of allowable.

The pressure boundary is the shell with pressure loads applied to the inside surface of the shell, heads and nozzles. The nozzles also have axial thrust loads applied that are equal to a capped end condition. The tube sheet has pressure applied outward to the inner edge of the gasket. The shell flanges have pressure acting on them only where the gasket prevents pressure from existing on both faces of the flange.

**Response****Limit stresses**

The bolt up and pressure load cases are examined together and evaluated to the non thermal load stress allowables shown below. The allowable stresses are based on Div.1 allowable stress values at the design temperatures of 300F and 925F. For the tube sheet the temperature of 300F is used.

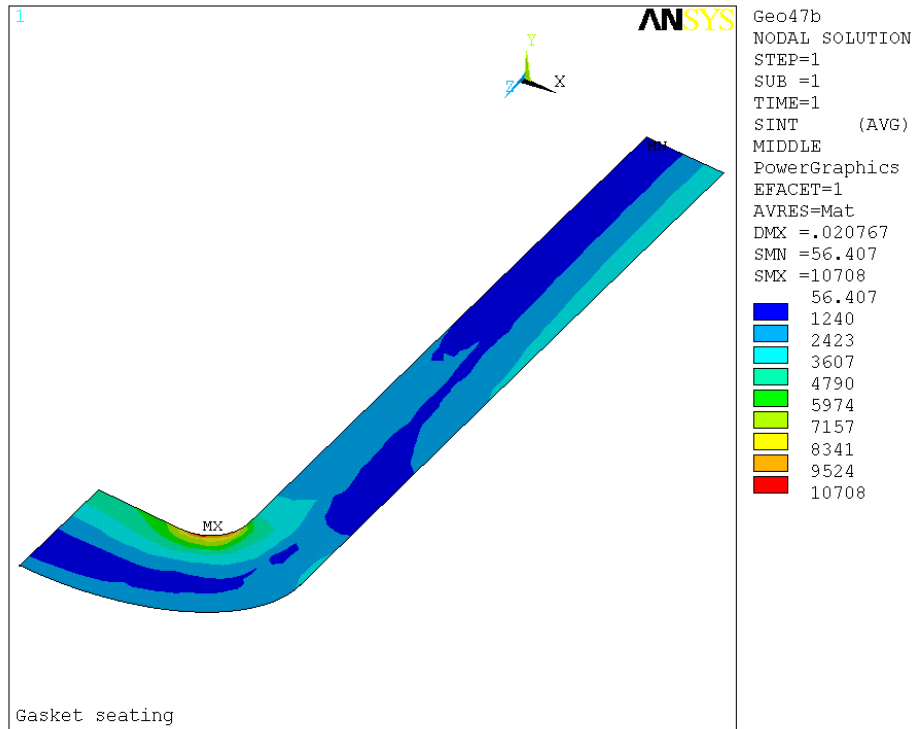
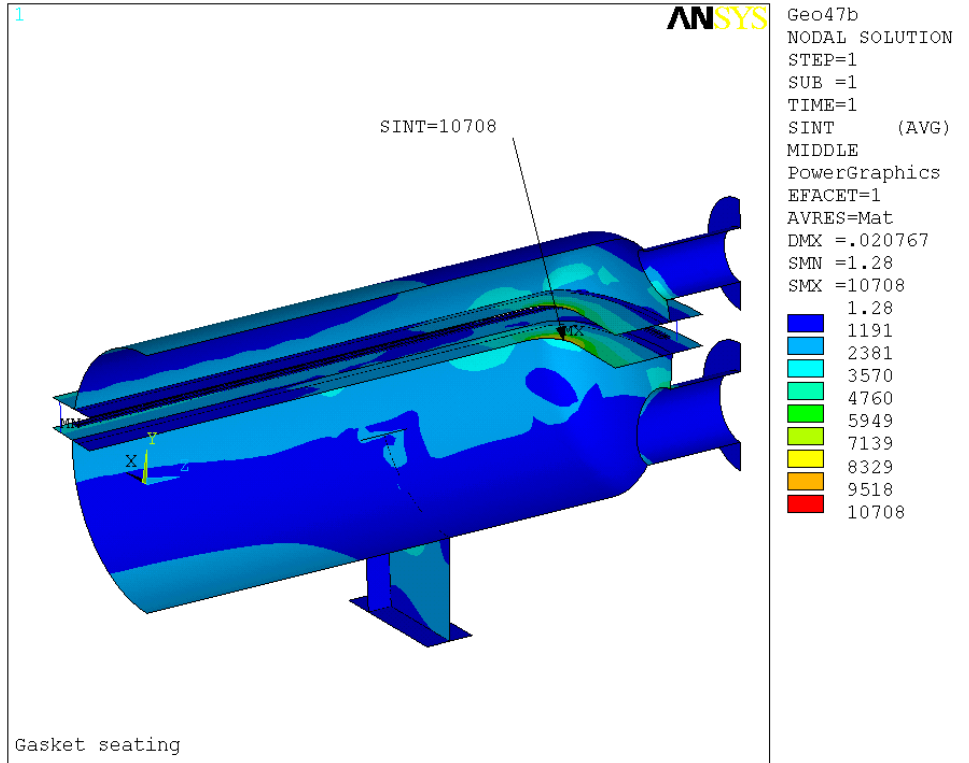
Location	Response		70/30	304SS
Tube sheet at mid span and mid length	bending	1.5 S	18.0	-
shell at mid length where the baffles connect	bending	1.5 S	18.0	16.05
shell at mid length where the baffles connect	bending	1.5 S	18.0	16.05
head at the junction to the flange	bending	3 S	36.0	32.1
flange	membrane	1 S	12.0	10.7
	bending	1.5 S	18.0	16.05
gasket	pressure	continuous		

The following 4 pages show membrane and membrane plus bending distributions of the bolt up case. A table on page 12 shows how the characteristic stresses compare to allowables and vary for the 3 pressure combinations.

The baffles have been removed in the stress plots to show those components making up the pressure boundary. The response of the baffles is discussed starting on page 24.

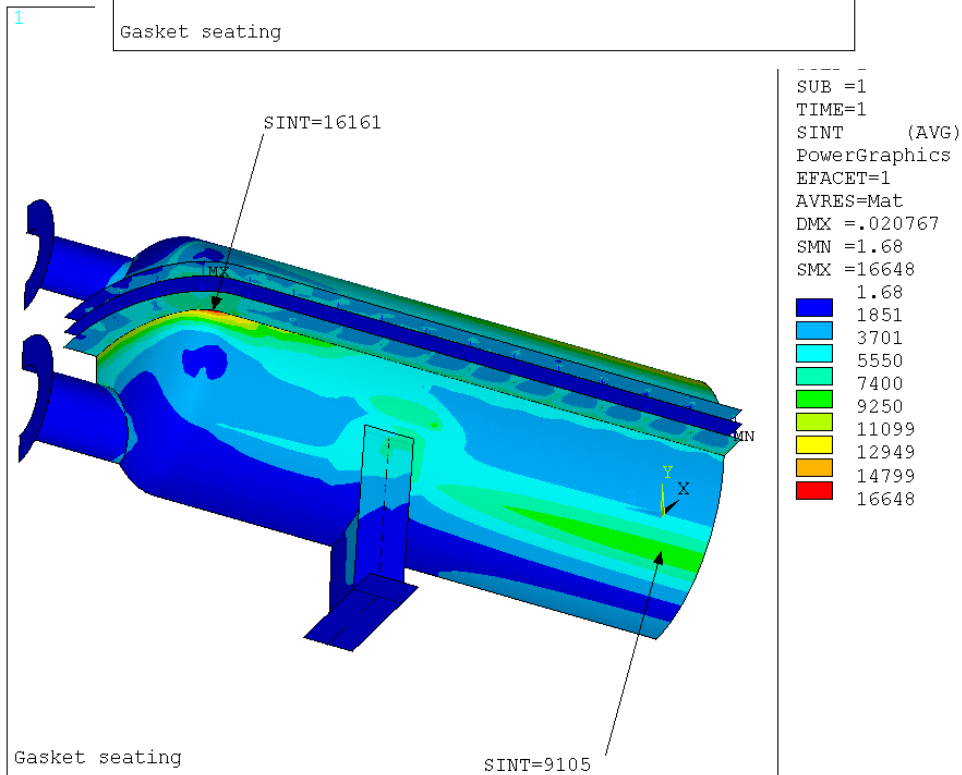
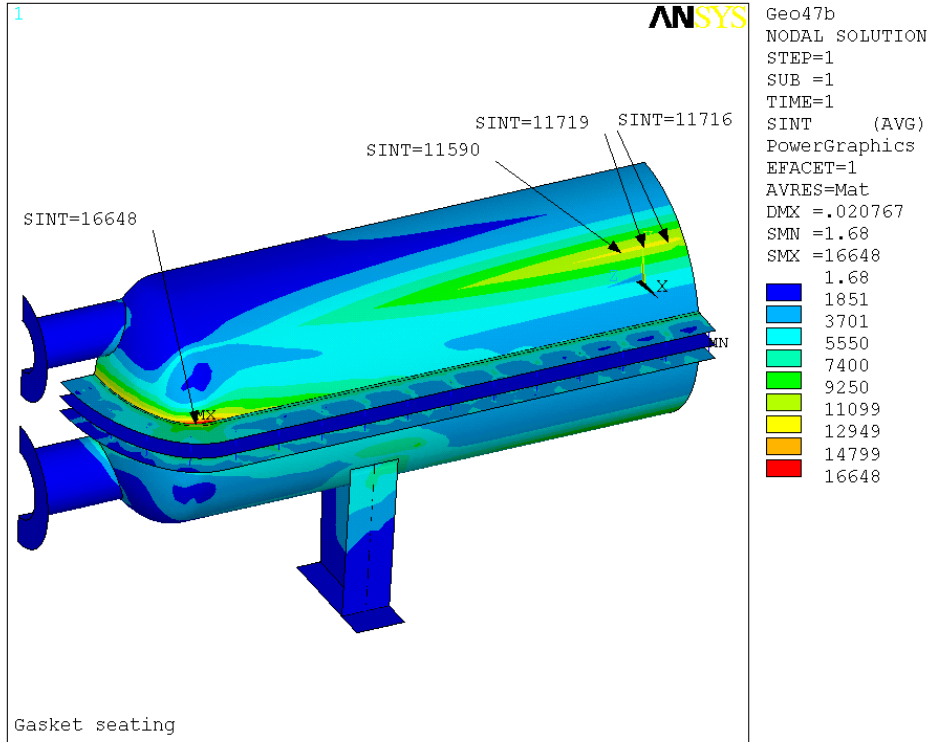
### Membrane Stresses

The plots below shows the maximum membrane stresses to be localized at the bottom flange radius at a level of about 1.0 S for 925F.



**Membrane plus bending stresses - shell**

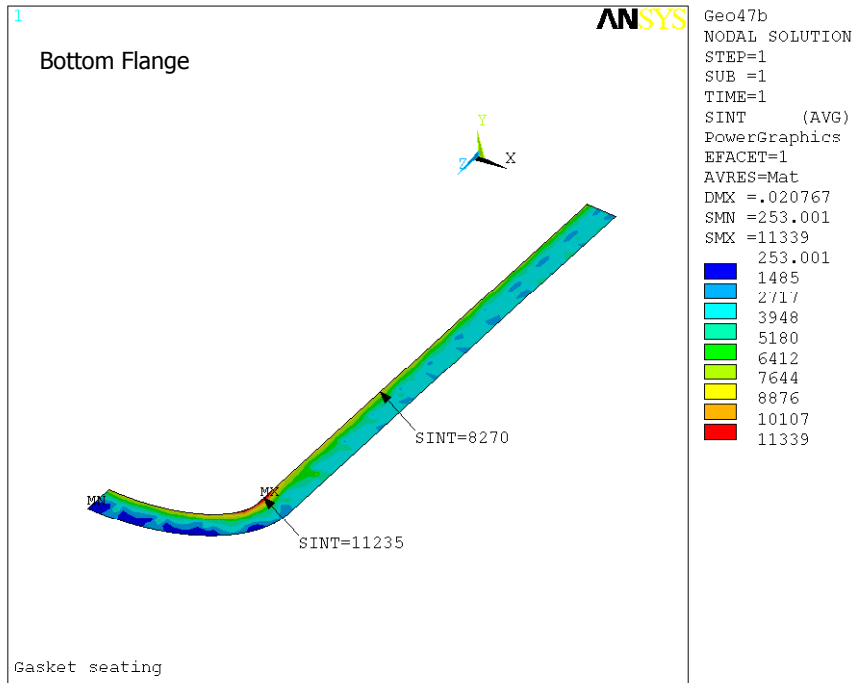
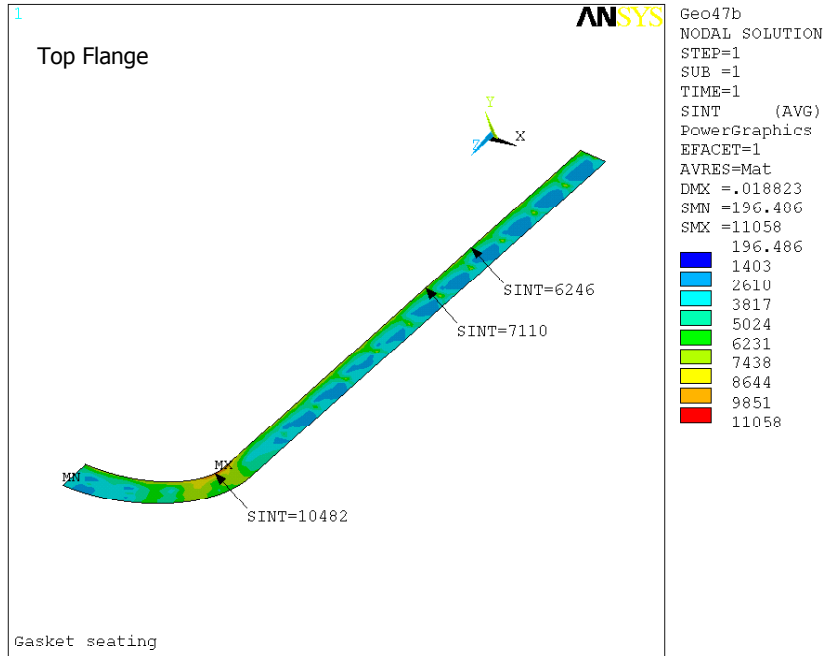
The surface stresses for the shells are shown below.



**Membrane plus bending stresses – shell flange**

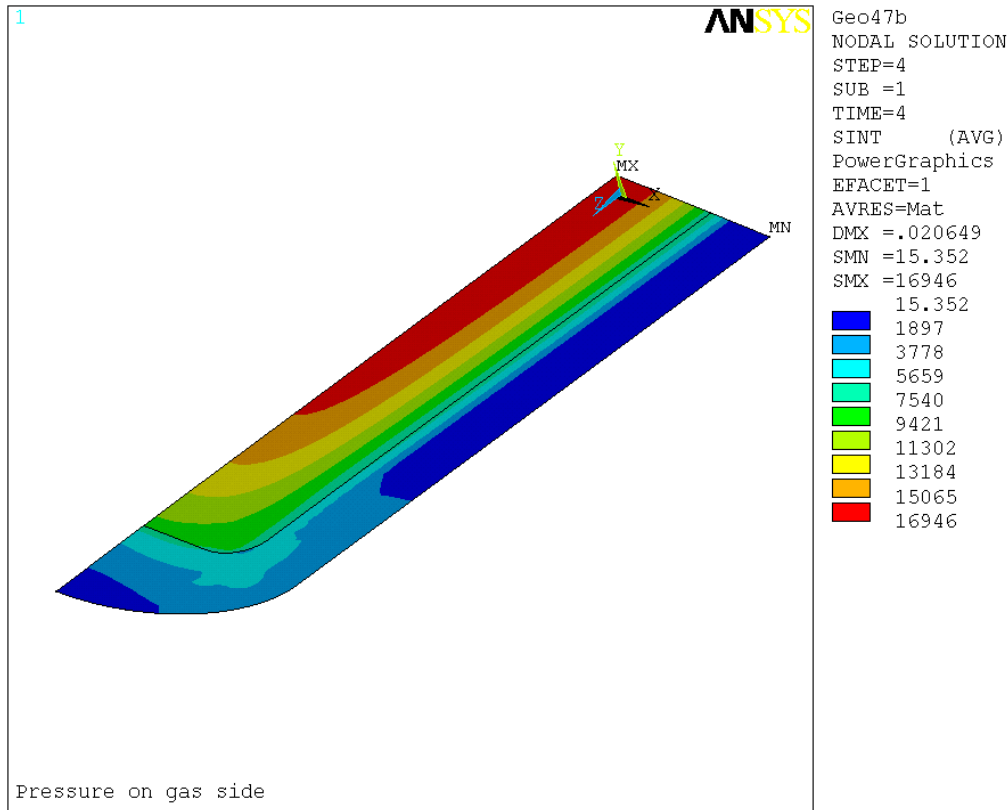
The surface stresses for top and bottom shell flanges are shown below. The area shown corresponds to the thinner portion of the flange where the face relief has reduced the thickness by 1/16". The high stress area in both flanges are located where the membrane stress is highest indicating the membrane is dominating..

The stresses along the straight length are more the product of bending from the bolt load.



**Tube sheet**

The tube sheet sees the largest stresses in the load case with the largest pressure side acting alone (load case 4). The stress plot of this case is shown below. In this plot the ligament efficiency factor is taken into account making these the average bending stresses in the ligaments between holes.



This compares reasonably with the hand calculation in Appendix C. The allowable stress using a mean temperature of 300F is 18000 psi. The 16946 psi level corresponds to a maximum mean temperature of slightly below 400F.



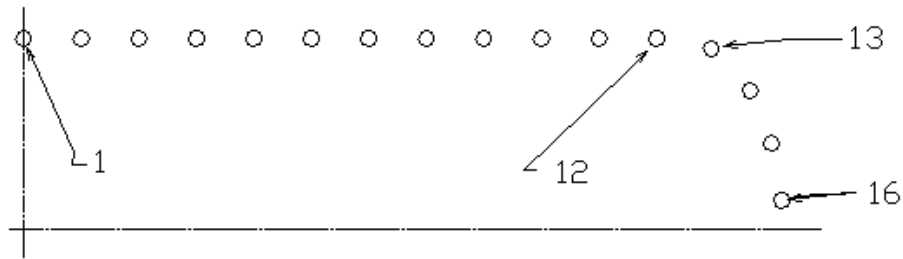
**Pressure Design Shell Stress Summary**

The pressure load cases 2 through 4 increase these basic distributions by a modest amount. A table of the stresses for these locations are tabulated below. The values are in psi.

Load Case	1	2	3	4	limit
P top	-	x	x	-	
P bottom	-	-	x	x	
Top half					
Shell bending at baffle	11,719	13,603	13,709	12,364	18,000
Shell bending at flange	16,648	16,834	18,061	18,974	36,000
Flange membrane	2773	3088	3084	2875	12,000
Flange bending	11,058	11,292	10,786	10,505	18,000
Bottom half					
Shell bending at baffle	9105	9773	10,698	10,446	16,050
Shell bending at flange	16,161	17,161	16,253	15,944	32,100
Flange membrane	3580	4000	3946	3657	10,700
Flange bending	11,235	11,407	11,545	11,570	16,050
Tube sheet					
Bending				16,946	18,000
Shear					9600

**Bolt Response**

The following table shows the values of bolt load relative to the gasket seating load. The ordering of the bolts is shown in the figure below.

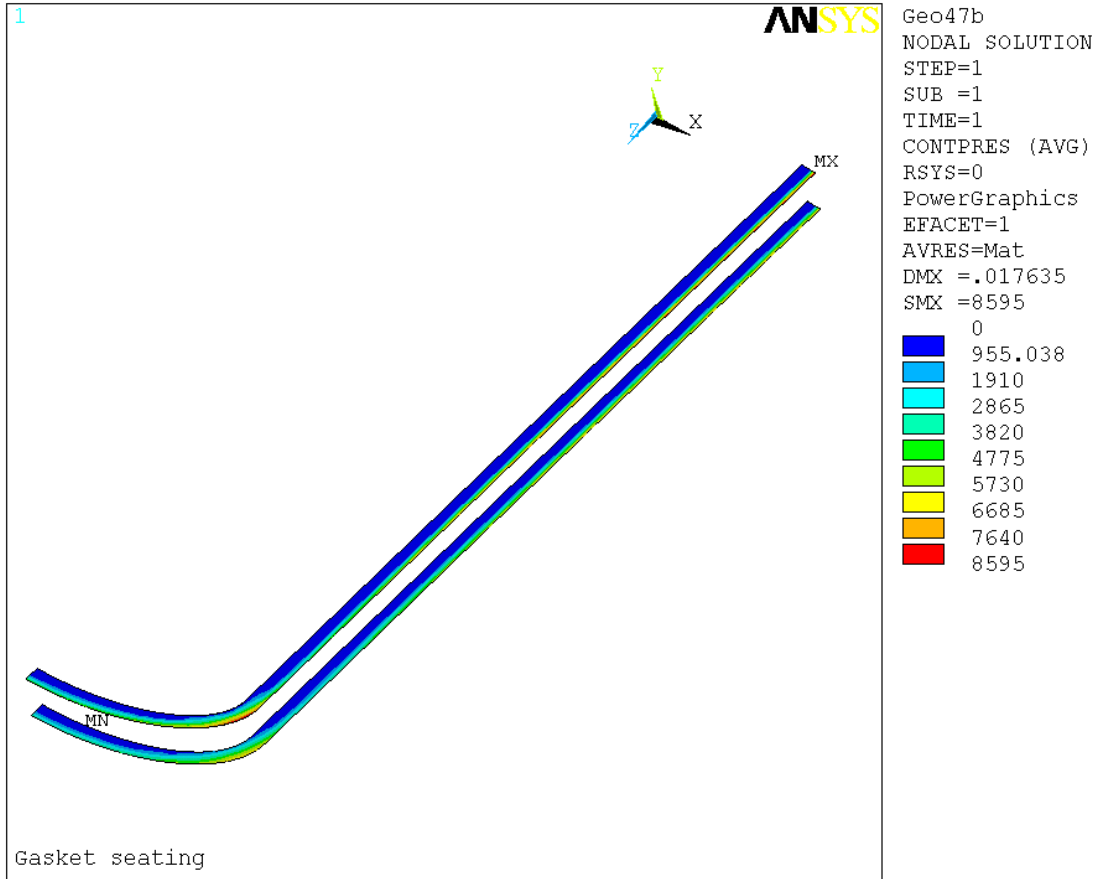


No.	P top	P both	P btm
1	0.87	0.90	1.02
2	0.87	0.90	1.01
3	0.87	0.90	1.01
4	0.88	0.91	1.02
5	0.89	0.91	1.02
6	0.89	0.92	1.02
7	0.90	0.94	1.03
8	0.92	0.96	1.04
9	0.93	0.97	1.04
10	0.95	0.99	1.05
11	0.98	1.01	1.05
12	0.99	0.99	1.00
13	0.98	0.95	0.94
14	0.99	0.98	0.98
15	0.99	0.99	1.00
16	0.99	0.99	1.00

This indicates the bolts will not experience much variation in load due to pressure loads.

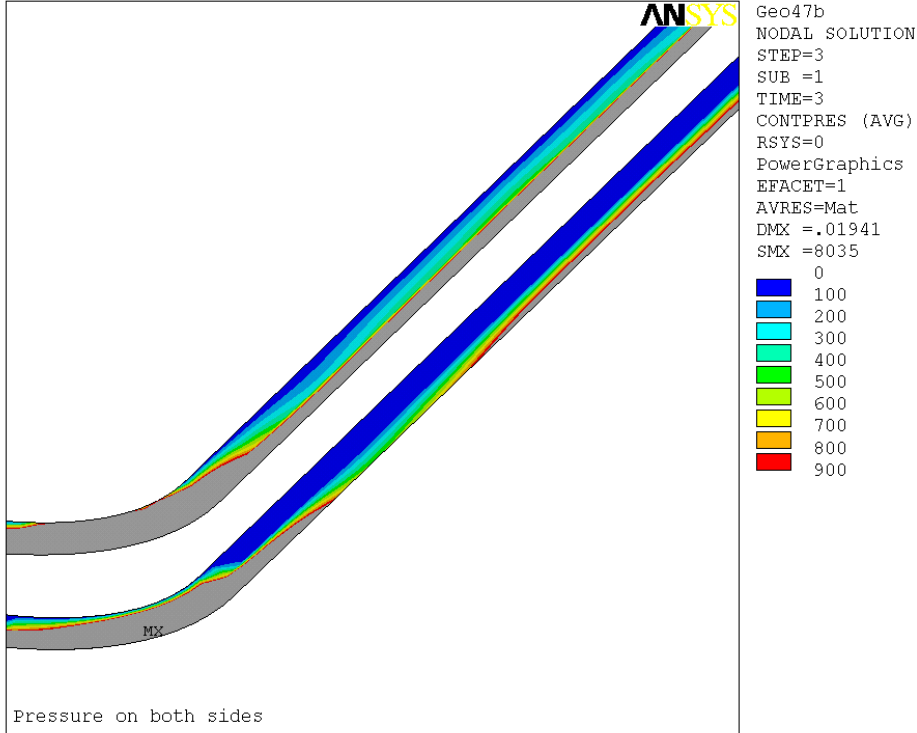
**Gasket pressure distributions**

The contact behavior representing the gasket is included in the FEA model and gasket pressure distributions can be illustrated. Below is a plot showing the contact pressure for the bolt up load case. Along the straight side and at the apex of the head the pressure concentrates on the outer edge as the flanges rotate in response to the bolt load. In between, at the knuckle of the head, high pressures are created across much of the width of the gasket.



The pressure load cases shift this distribution somewhat for load cases where pressure exists only on one side. In these cases the tube sheet tends to deform into the inner edge of the flange of the non-pressurized side and shift the gasket pressure pattern towards this inner edge.

A close examination of the gasket pressures for load case 3 (pressure both sides) indicates a region in the lower gasket may experience low sealing pressures. The following figure shows where contact pressures fall between 0 and 900 psi. In this figure the gray represents regions exceeding 900 psi. Ideally this band of gray should extend around the whole gasket.



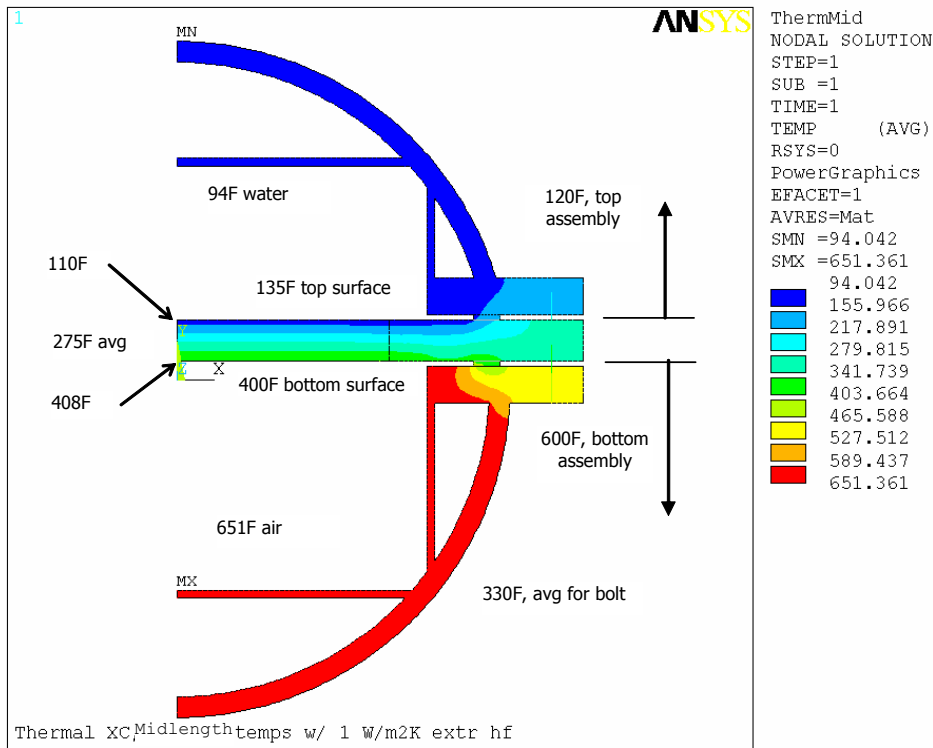
This pattern suggests that slightly higher bolt preloads along this stretch is desirable.

**Thermal Analysis**

The thermal loads considered are from an averaged temperature distribution. Specifically it is the averaging of the temperature on the bottom and top halves based on a 2D analysis at the mid length of the cooler. The surface temperatures of the tube sheet are defined from this same analysis. Description of the modeling is in Appendix B.

**Results – Thermal Analysis**

The temperature distribution for the thermal analysis of the cooler cross section at mid length is shown below. The 2D temperature distribution indicates that the interior temperatures dominate the chamber temperatures when any insulation of the outer surface is assumed. This situation is not true for the flanges where temperature compatibility exists.



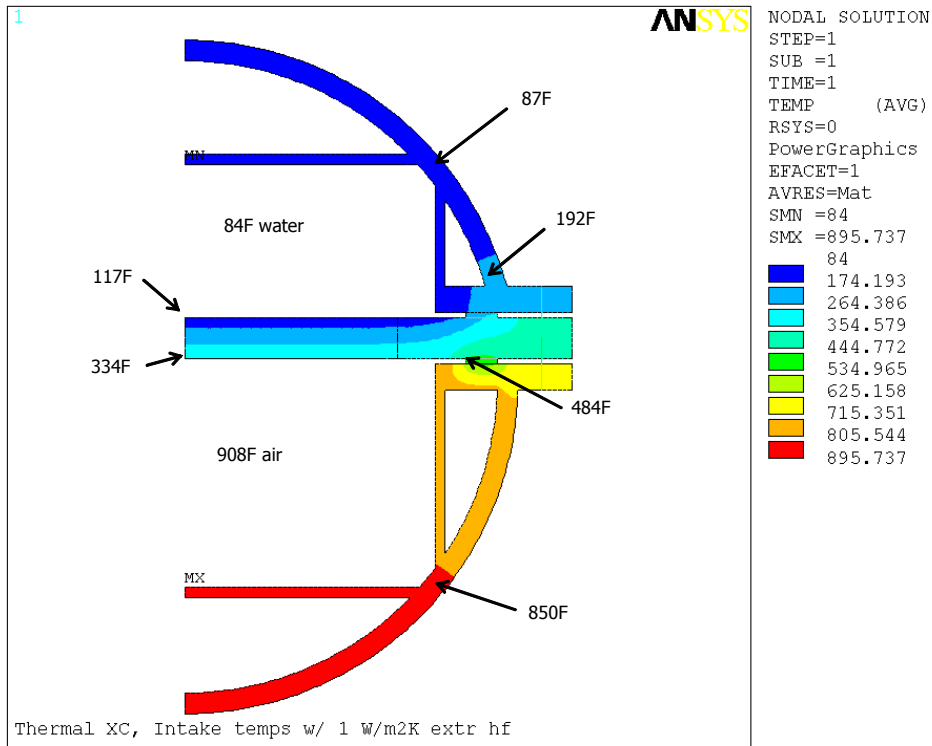
The temperatures indicated on the left side in the figure above denote specific results. The temperatures on the right are average temperatures of the entire half for use in the structural analyses.

For the thermal loads in the structural model the tube sheet is assumed to have a uniform top surface temperature of 135F and bottom temperature of 400F. The entire bottom assembly (shell, baffles, flange, nozzles and support) is assumed at 600F. The top assembly is assumed at 120F.

The ASME Code produces temperature limits on materials through their allowable stress tables. For C-71500 alloy (70/30 CuNi) the highest temperature with a stress value is 700F. For the design conditions the surface temperature must remain below this temperature.

The figure below shows the conditions at the first heat tube row (closest to inlet). The centerline temperatures reproduce results from Thermacore’s 1D analysis (2/04). The hottest spot is near the gasket and is less than 500F.

It also checks the hottest spot in the top assembly, also by the gasket. Since water will be present the temperature needs to remain below 212F which it does by 20F.

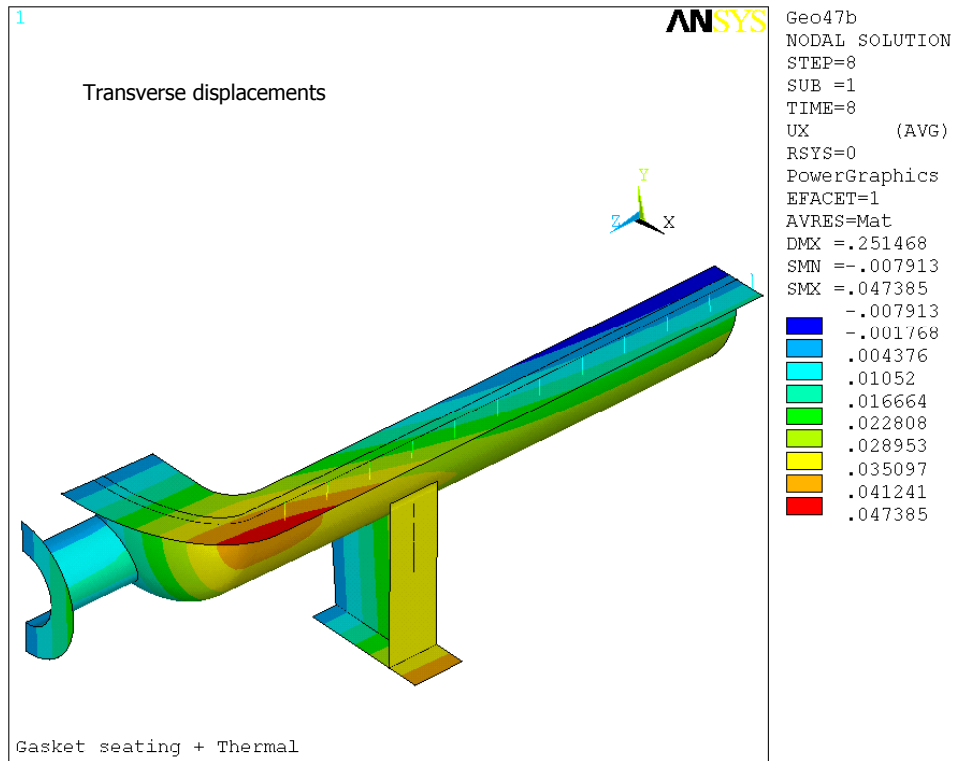
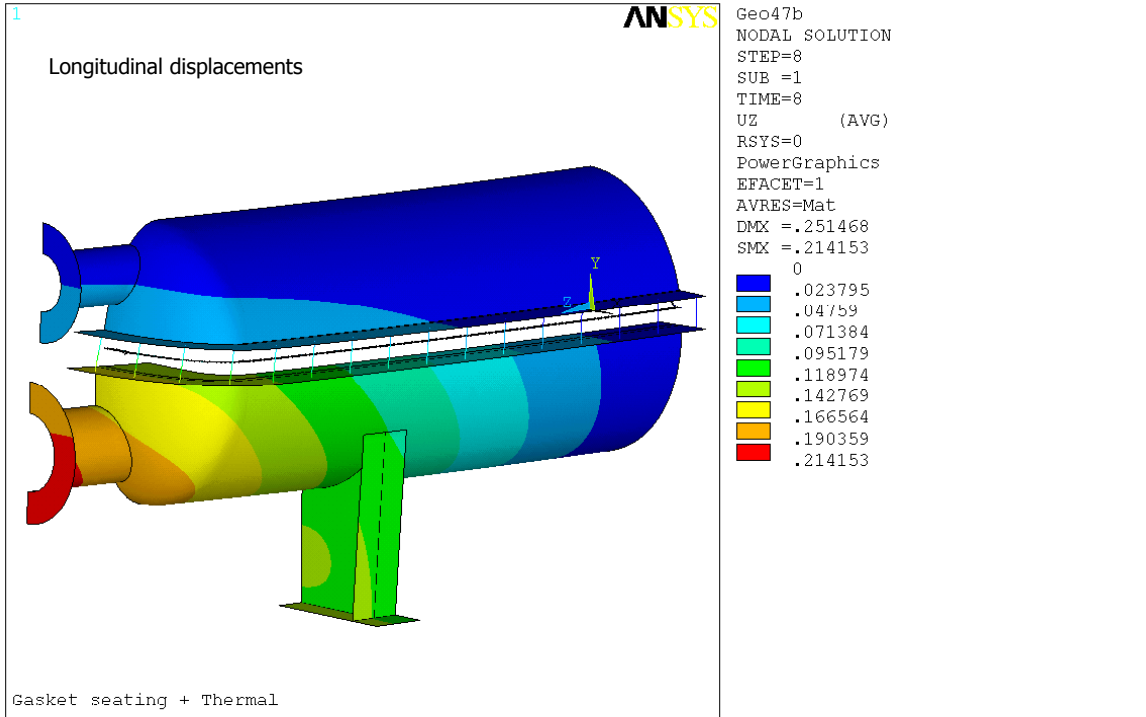


It is expected that this 2D temperature distribution changes along the length of the cooler. Thermacore’s thermal analysis of the system started with water and air temperatures along the length and performed a 1D analyses through the thickness of the tube sheet. The 1D and 2D evaluations agree and are useful for a general temperature response but not a localized response. A 3D thermal analysis would be necessary for accurate temperature distributions.

The temperature results represent very generalized thermal conditions that should be effective to determining the general structure response. The distribution ignores temperature gradients along the length of the cooler as well as for items that have the ability to cool to the surroundings. It is expected that the temperature distribution in the flanges would not be the same as the shell, as assumed here, and the response of the flanges to thermal loads would be less severe than shown here.

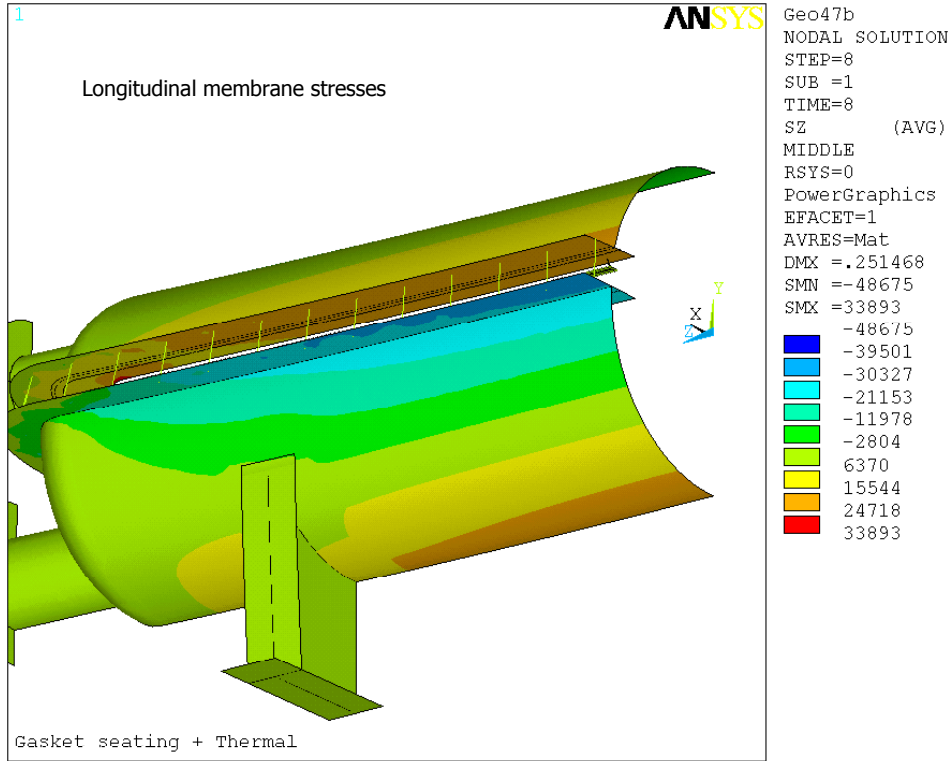
### Distortion

The axial (UZ) and transverse (UX) displacements from the temperature distribution and bolt up are shown below. Note in the axial plot how the bottom half grows much more than the top. The transverse displacements are shown on the bottom half and shows the knuckle area moving outward while the flange at mid length is moving inward.



### Overall Response

The axial membrane stresses from the temperature difference and bolt up are shown below. Note at mid length that the top flange stress reaches 19.8 ksi in tension while at the same location the bottom flange reaches 33.3 ksi in compression. This level is high and suggests flange warping would occur if not restrained by the top flange through the bolts.

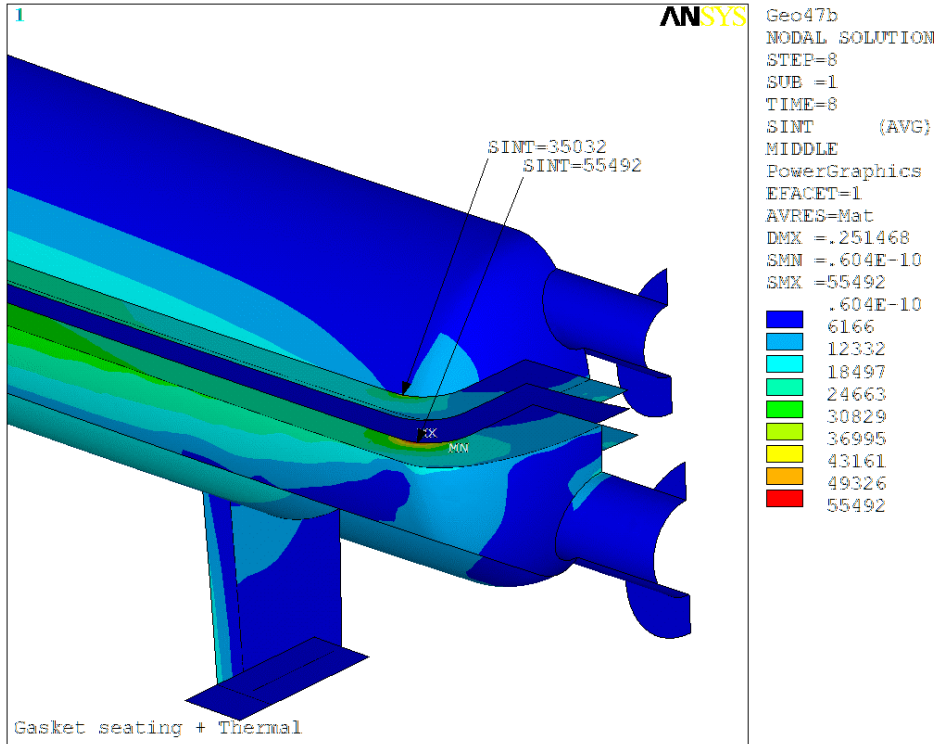


Also noteworthy is that the very bottom of the shell at mid length reaches 18.4 ksi in tension indicating the bottom shell half is resisting a sizeable bending moment about a horizontal, transverse axis.



**Membrane stresses**

The membrane stresses are limited to 3 Sm for load cases including thermal loads. The following figures show the distribution of these stresses. The highest stresses occur in the radiused corner of the bottom shell flange (highest membrane stress point in non-thermal loads, also). The plots of transverse displacement on the previous page show this point moving outward while the mid length moved inward so this point will be compressive when hot.

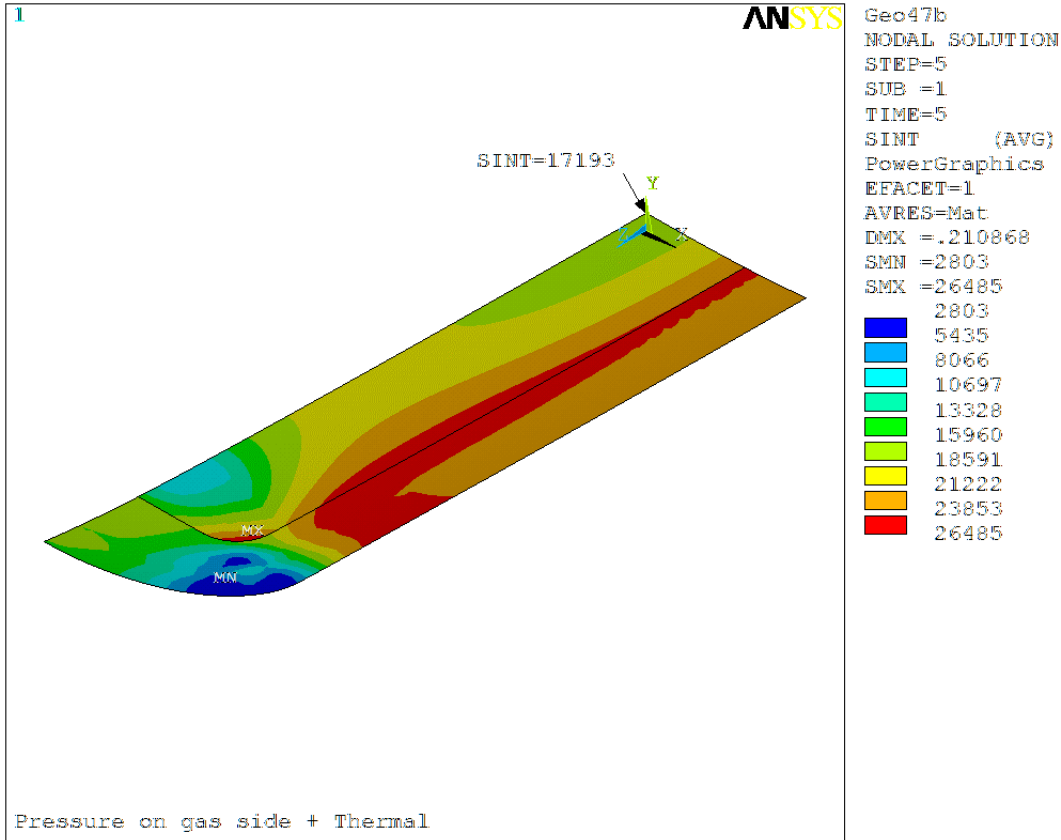


This pattern is the same as seen for bolt up except 5x larger.

**v**

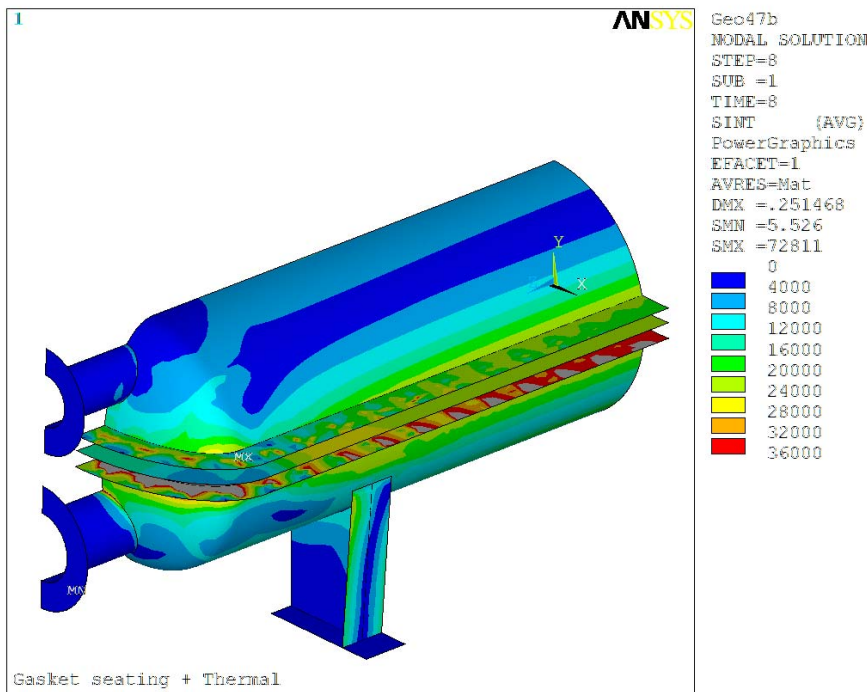
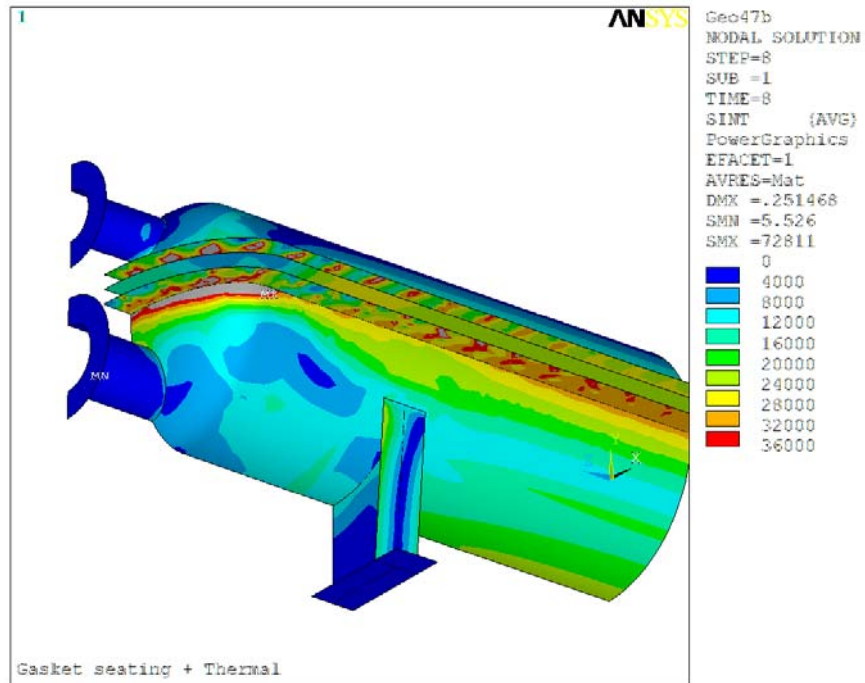
### Membrane plus Bending Stresses

The membrane plus bending stresses in the **tube sheet** are be limited to 3 S or 36 ksi. The line through the interior in the plot below is the boundary between regions modeled with equivalent material properties for holes and solid material. The key locations are the center and the outer ligament line along the length. The maximum membrane plus bending stresses are 26.5 ksi or slightly more than 2 S.



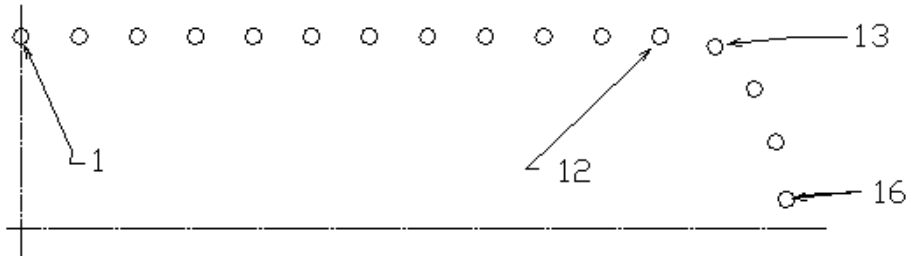
No limits are placed on the membrane plus bending stresses in the shell to flange junction for thermal load cases. However it is a good idea to get a sense for where these stresses are high and see if excessive deflections may occur. The following plots show the membrane plus bending stress.

Note in the view from the under side that the bottom flange to shell junction has a band of stresses exceeding 36 ksi. For 304SS material at high temperature, the linear elastic methods will under predict deformations. Since this is a sealing surface too much deformation could affect gasket sealing.



**Bolt Response**

The following table shows the values of bolt load relative to the gasket seating load. The ordering of the bolts is shown in the figure below.



Bolt No.	T+P btm	T+P both	T+P top	T only
1	1.06	0.99	0.96	1.03
2	1.06	1.00	0.97	1.04
3	1.08	1.01	0.99	1.05
4	1.10	1.04	1.02	1.07
5	1.12	1.07	1.06	1.11
6	1.14	1.10	1.09	1.13
7	1.17	1.15	1.15	1.17
8	1.21	1.20	1.20	1.21
9	1.21	1.22	1.22	1.22
10	1.10	1.12	1.13	1.11
11	0.86	0.91	0.93	0.89
12	0.92	0.99	1.04	0.97
13	1.52	1.58	1.61	1.56
14	1.34	1.42	1.45	1.38
15	1.20	1.26	1.30	1.24
16	1.10	1.16	1.21	1.15

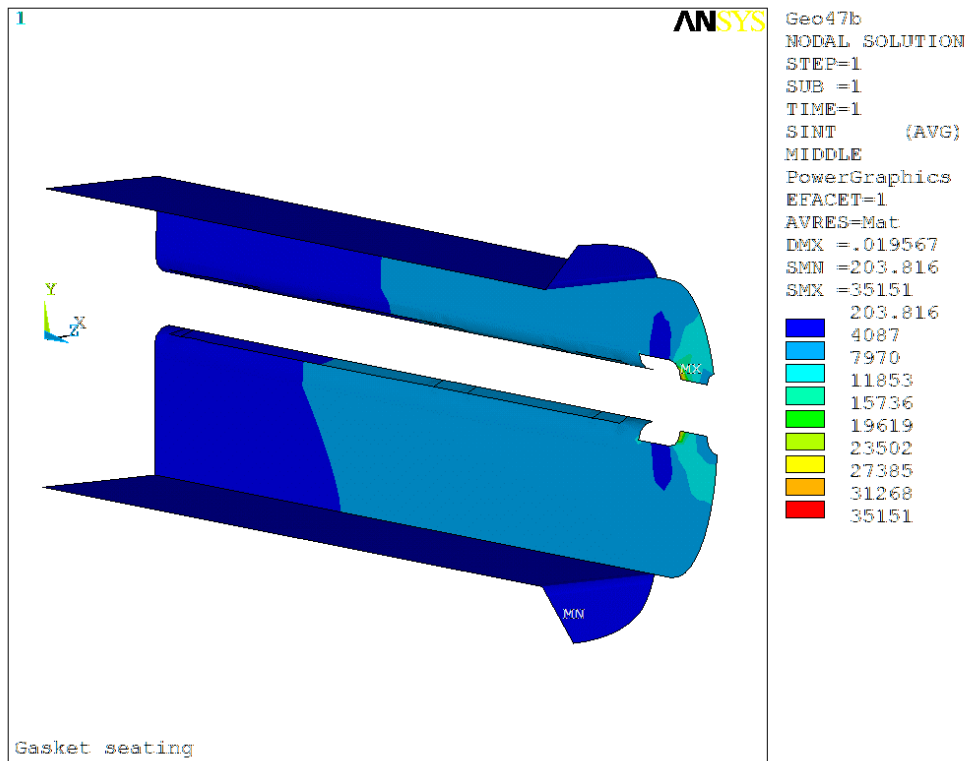
These results indicate the bolt load will not increase significantly for the thermal load. The exception to this are the bolts near the knuckle of the head where loads go up by as much as 60%.

## Baffles

The stress plots so far have not included the baffles as they are not a part of the pressure boundary. The function of the baffles is to direct flow. The design pressure loads are not considered to act solely on one side of a baffle and as a result they develop stresses based on displacement compatibility at the welded connections to the shell.

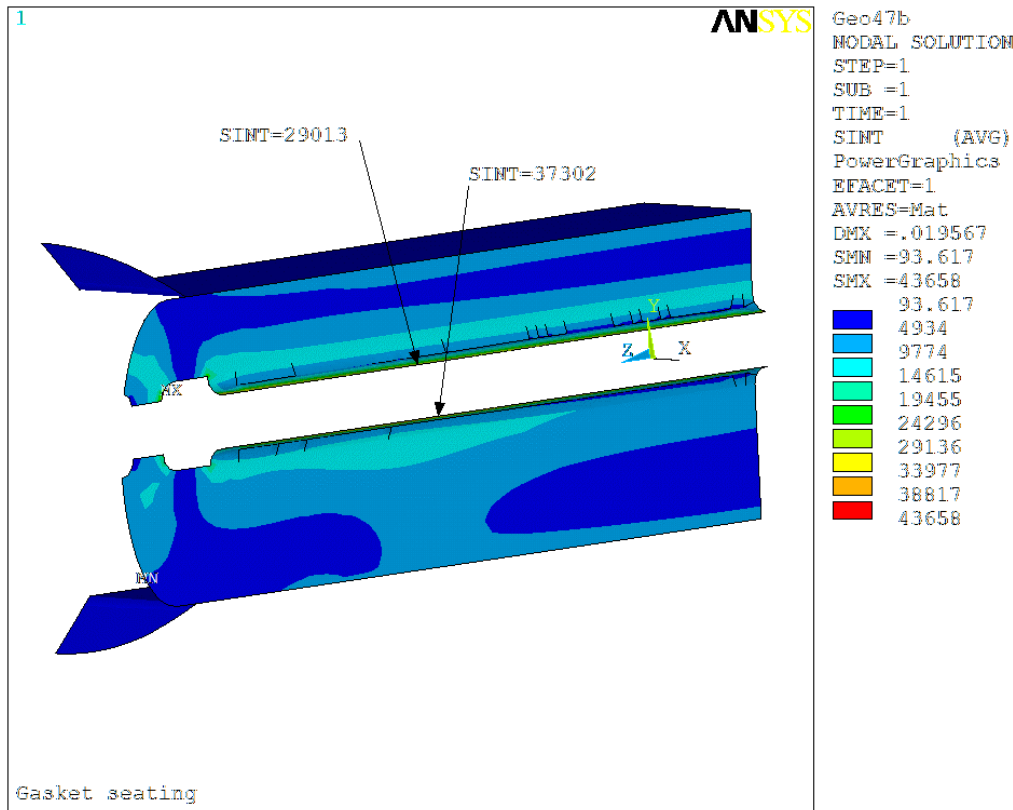
A detailed evaluation of the baffles will be performed during shock and vibration analysis. For the prototype it is most important to make sure a crack in a baffle cannot propagate to the pressure boundary. Such cracking is typically from fatigue.

The **membrane** stresses during bolt up are shown below.



The key locations for the baffles are in two locations on the vertical baffles. The first is the highest stress in the plot above where the baffle transitions from attaching to the edge of the shell flange to the top of the flange. It is extremely localized and increases three fold when thermal loads are included.

The second location is the attachment of the baffle to the flange edge where flange rotation induces bending stresses. The plot on the next page shows **membrane plus bending** stresses for the same load case as above. The stresses exist and are uniform over a considerable length of the baffle. They do not change significantly between load steps compared to the stresses of bolt up.



Both of these locations are welds to the shell flange within the gasket 'circle'. In order for cracking to propagate to the pressure boundary it would have to travel across several inches of material.

The stress in the shell flange is also high near where the baffle has its highest stress, at least relatively. Recall that the radius on the shell flange cutout was a local high stress point in the membrane stress results for both bolt up and thermal loads. Also recall that this radiused point on the flange would be in compression during thermal loading. This would inhibit, not promote crack growth when hot and instead produce tensile stresses when cooled.

The fabrication sequence will have a difficult step of making welds in the closed space within the head between the baffle and either the head or flange. If the welding of the vertical baffles to the tube sheet within the heads can be avoided it would simplify construction and avoid a potential source of cracking.

### References

1. ASME B&PV Code, Sect VIII, Divisions 1 and 2
2. ANSYS Finite element analysis software, version 8.0
3. Thermacore 1D thermal analysis
4. TEMA Manual

<b>TABLE 1 - HEAT PIPE COOLER - DESIGN PERFORMANCE DATA</b>		
<b>PERFORMANCE DATA</b>	<b>Bleed Air Cooler</b>	
<b>COOLER CHARACTERISTICS:</b>	<b>AIR SIDE</b>	<b>WATER SIDE</b>
FLUID CIRCULATED	AIR (2450 SCFM)	SEAWATER
FLOW RATE (LB/HR)	11,231	46,350
INLET TEMPERATURE (°F)	925	85
OUTLET TEMPERATURE (°F)	425	116.3
PRESSURE DROP (ALLOW/CALC) (PSI)	2.46/1.50	3.000/1.406
VELOCITY AT INLET FLANGE FACE (FT/SEC)	198.9	4.14
MAX. INTERNAL VELOCITY (FT/SEC)	85 to 90	3.21
NUMBER OF PASSES	1	1
DESIGN PRESSURE (PSIG)	100	50
TEST PRESSURE (PSIG)	150	100
DESIGN TEMPERATURE (°F)	925	300
LOG MEAN TEMPERATURE DIFFERENTIAL (LMTD) (°F)	535.878	
HEAT TRANSFER RATE CLEAN (BTU/HR/SQ FT./°F)	19.2	
HEAT TRANSFER SURFACE AREA (SQ FT.)	140.59	
HEAT EXCHANGE (BTU/HR) (APPROX)	1,423,800	
WEIGHT DRY/FULL OF WATER (LBS)	800/900	
<b>HEAT PIPE CHARACTERISTICS:</b>		
HEAT PIPE WORKING FLUID	WATER	
MAX. HEAT LOAD ? HEAT PIPE (WATTS/PIPE)	2863	
MAX WATER SIDE PIPE WALL TEMP. (OF) at 925 inlet air	172	
MAX. WATER SIDE PIPE WALL TEMP. (OF) at 700 inlet air	150	
SINGLE PIPE THERMAL RESISTANCE (°C/WATT)	0.06	

**TABLE 1B**  
**SECTION I; SECTION III, CLASS 2 AND 3;\* AND SECTION VIII, DIVISION 1**  
**MAXIMUM ALLOWABLE STRESS VALUES S FOR NONFERROUS MATERIALS**  
(\*See Maximum Temperature Limits for Restrictions on Class)

Line: 18	Page: 190 - 191	Line: 18	Page: 192	Line: 18	Page: 193
Addenda		Maximum Allowable Stress, ksi (Multiply by 1000 to Obtain psi), for Metal Temperature, °F, Not Exceeding			
Nominal Composition	...	-20 to 100	13.3	950	...
Product Form	Plate, sheet	150	12.9	1000	...
Spec. No.	SB-171	200	12.6	1050	...
Type/ Grade	...	250	12.3	1100	...
Alloy Desig./ UNS No.	C71500 ← 70/30	300	12.0 ←	1150	...
Class/ Cond./ Temper	O25	350	11.7	1200	...
Size/ Thickness, in.	<= 2.5	400	11.5	1250	...
P-No.	34	450	11.2	1300	...
Min. Tensile Strength, ksi	50	500	11.0	1350	...
Min. Yield Strength, ksi	20	550	10.8	1400	...
Applic. and Max. Temp. Limits (NP = Not Permitted) (SPT = Supports Only)		600	10.7	1450	...
I	NP	650	10.6	1500	...
III	700	700	10.4	1550	...
VIII-1	700	750	...	1600	...
External Pressure Chart No.	NFC-4	800	...	1650	...
Notes		850	...		
		900	...		

**General Notes**

- (a) The following abbreviations are used: ann., annealed; Applic., Applicability; Cond., Condition; cond., condenser; Desig., Designation; exch., exchanger; extr., extruded; fin., finished; fr., from; rel., relieved; rd., rolled; Smls., Seamless; Sol., Solution; treat., treated; and Wld., Welded.
- (b) The stress values in this Table may be interpolated to determine values for intermediate temperatures.
- (c) When used for Section III Class MC design, the stress values listed herein shall be multiplied by a factor of 1.1 (NE-3112.4); these values shall be considered as design stress intensities or allowable stress values as required by NE-3200 or NE-3300, respectively.
- (d) For Section VIII applications, stress values in restricted shear, such as dowel bolts, rivets, or similar construction in which the shearing is so restricted that the section under consideration would fail without reduction of areas, shall be 0.80 times the values in this Table.
- (e) For Section VIII applications, stress values in bearing shall be 1.60 times the values in this Table.

**TABLE 1A**  
**SECTION I; SECTION III, CLASS 2 AND 3;\* AND SECTION VIII, DIVISION 1**  
**MAXIMUM ALLOWABLE STRESS VALUES S FOR FERROUS MATERIALS**  
(\*See Maximum Temperature Limits for Restrictions on Class)

Line: 15	Page: 86 - 87	Line: 15	Page: 88	Line: 15	Page: 89
Addenda		Maximum Allowable Stress, ksi (Multiply by 1000 to Obtain psi), for Metal Temperature, °F, Not Exceeding			
Nominal Composition	18Cr - 8Ni	-20 to 100	20.0	950	10.6
Product Form	Plate	150	...	1000	10.4
Spec. No.	SA-240	200	16.7	1050	10.1
Type/ Grade	304	250	...	1100	9.8
Alloy Desig./ UNS No.	S30400	300	15.0	1150	7.7
Class/ Cond./ Temper	...	400	13.8	1200	6.1
Size/ Thickness, in.	...	500	12.9	1250	4.7
P-No.	8	600	12.3	1300	3.7
Group No.	1	650	12.0	1350	2.9
Min. Tensile Strength, ksi	75	700	11.7	1400	2.3
Min. Yield Strength, ksi	30	750	11.5	1450	1.8
Applic. and Max. Temp. Limits (NP = Not Permitted) (SPT = Supports Only)		800	11.2	1500	1.4
I	1500	850	11.0	1550	...
III	NP	900	10.8	1600	...
VIII-1	1500			1650	...
External Pressure Chart No.	HA-1				
Notes	G12, G18, T8				

**General Notes**

- (a) The following abbreviations are used: Applic., Applicability; Cond., Condition; Desig., Designation; Smls., Seamless; and Wld., Welded.
- (b) The stress values in this Table may be interpolated to determine values for intermediate temperatures.
- (c) When used for Section III Class MC design, the stress values listed herein shall be multiplied by a factor of 1.1 (NE-3112.4); these values shall be considered as design stress intensities or allowable stress values as required by NE-3200 or NE-3300, respectively.
- (d) For Section VIII applications, stress values in restricted shear such as dowel bolts or similar construction in which the shearing member is so restricted that the section under consideration would fail without reduction of area shall be 0.80 times the values in the above Table.
- (e) For Section VIII applications, stress values in bearing shall be 1.60 times the values in the above Table.
- (f) Stress values for -20 to 100°F are applicable for colder temperatures when toughness requirements of Section III or Section VIII are met.

**General Requirements**

- G12 At temperatures above 1000°F, these stress values apply only when the carbon is 0.04% or higher on heat analysis.
- G18 For Section I applications, this material may not be used for parts of firetube boilers under external pressure.

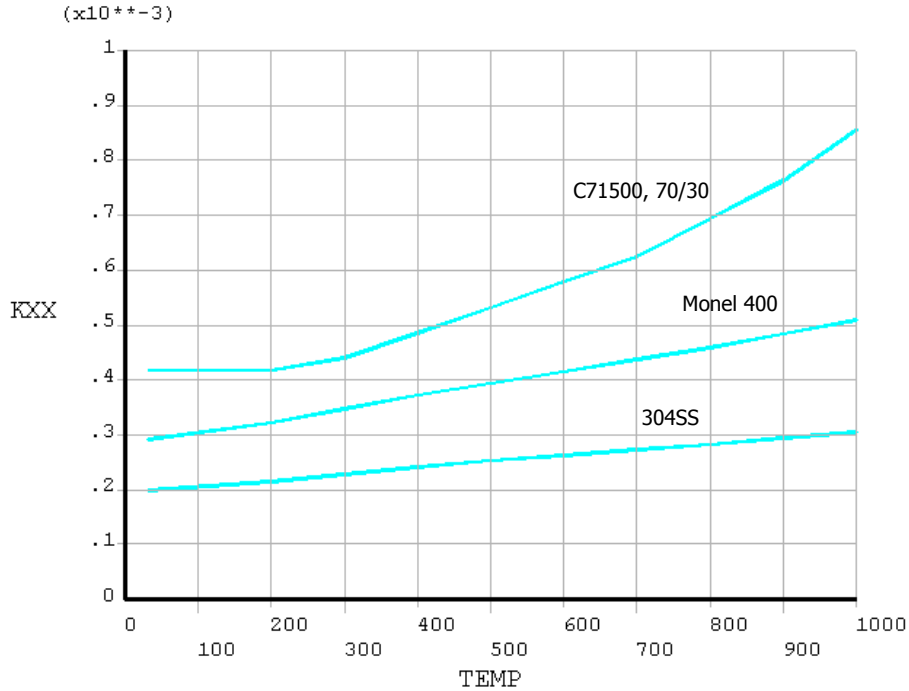
**Time-Dependent Properties**

- T8 Allowable stresses for temperatures of 1100°F and above are values obtained from time-dependent properties.

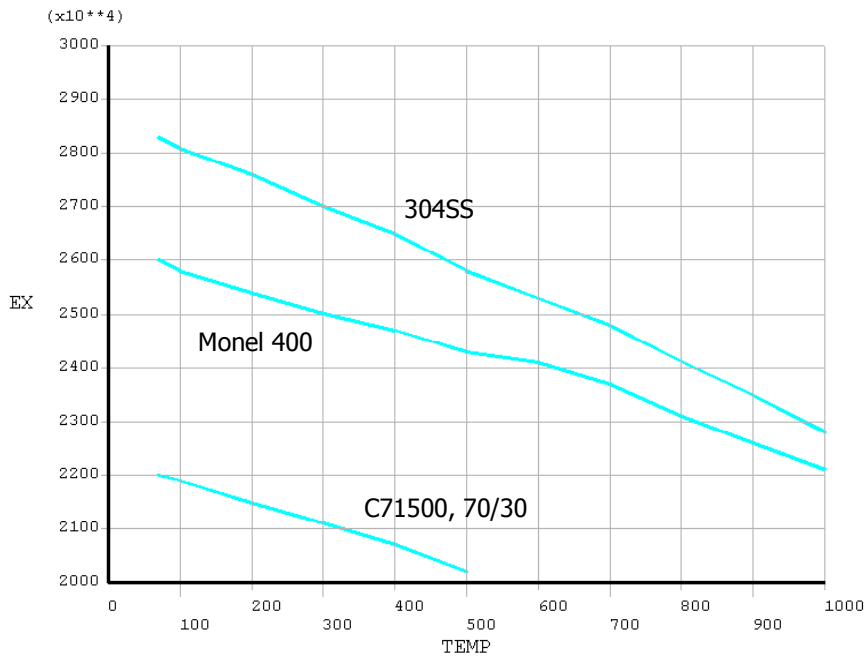


**Material property data**

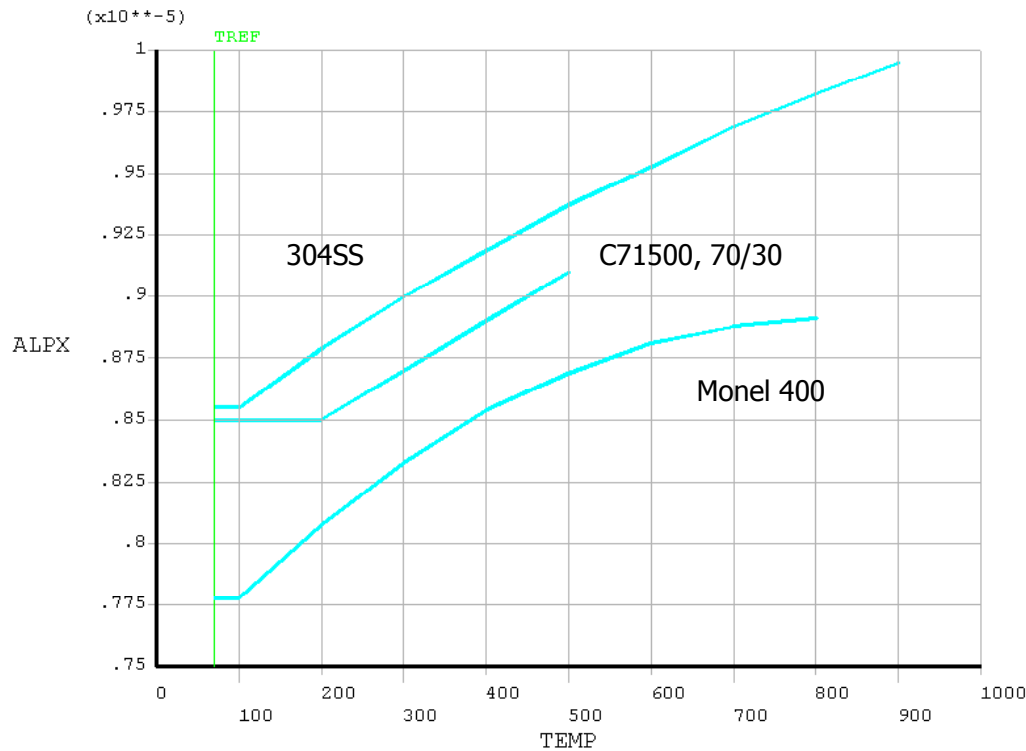
The **thermal conductivity** of the materials is shown below in units of BTU/s inch F.  
(1 W/mK = 1/1055/39.37/1.8 BTU/s inch F.)



The **elastic modulus** is shown below in units of psi. The value used for the perforated portion of the tube sheet is be 75% of that shown for 70/30.



The **thermal expansion coefficient** is shown below in units of inches per inch per degree F.



## Modeling

The figure on the cover page shows the 3D model. It is a quarter of the full component recognizing symmetry at the vertical, transverse plane and vertical longitudinal plane. The colors represent different material types.

The cooler is modeled using shell, beam and contact elements. The shell is used for all plate components, the beam is used for the bolts and contact is used for the gasket response.

The bolted connection of the flanges and tube sheet are modeling using a combination of two contacts pair sets and a series of beams representing the bolts. The contact sets correspond to the 2 gaskets, one on top of the tube sheet and one beneath it.

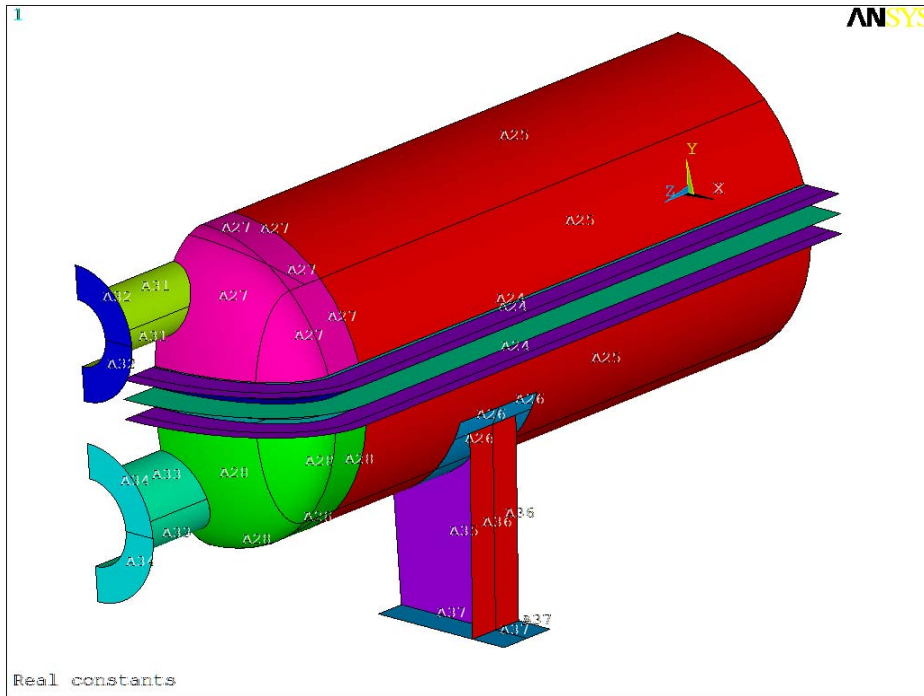
The joint is 'preloaded' by specifying initial strains in each bolt that produce an axial tensile clamping force across the flanges. The tensile bolt sought is the 2620 lbs tensile force that produces the necessary gasket seating pressure.

The model has symmetry boundary conditions applied to all nodal degrees of freedom on the transverse and longitudinal planes. Vertically the model is restrained at the base of the saddle support. There is no horizontal restraint at this base plate.

The model is run in 8 load steps. All load steps have gravity and bolt up loads included. The combination of thermal and pressures is described in the load case section.

The ligament bending stresses is determined directly by modifying the shell element parameter for the distance from the neutral axis. Normally a value of  $t/2$  is used. For ligament stresses the neutral axis distance is set to  $t/2$  times the ligament factor of 1.88. As a result the bending stresses in the perforated region are the average across the ligament, consistent with ASME methods.

The figure below shows the different areas with notation of the real constant used to define thickness. The table under the figure relates real constant numbers to thickness.



Real	Thickness	Real	Thickness	Real	Thickness
21	0.9375	27	0.5625	33	0.12
22	0.8125	28	0.6875	34	0.5
23	1	29	0.1875	35	0.25
24	0.9375	30	0.125	36	0.375
25	0.5	31	0.25	37	0.375
26	0.875	32	0.5		

The bolts are modeled uniquely, each with the prestrain needed to produce 2620 lbs. The first bolt lies on the symmetry plane and should only be represented with half a bolt.

Bolt No.	Area	Ixx	Iyy	Sxx	Syy	prestrain
1	0.113	2.03E-03	2.03E-03	0.26821	0.26821	7.75E-03
2	0.226	4.06E-03	4.06E-03	0.26821	0.26821	7.71E-03
3	"	"	"	"	"	7.60E-03
4	"	"	"	"	"	7.41E-03
5	"	"	"	"	"	7.15E-03
6	"	"	"	"	"	6.81E-03
7	"	"	"	"	"	6.38E-03
8	"	"	"	"	"	5.89E-03
9	"	"	"	"	"	5.35E-03
10	"	"	"	"	"	4.74E-03
11	"	"	"	"	"	4.04E-03
12	"	"	"	"	"	3.42E-03
13	"	"	"	"	"	3.28E-03
14	"	"	"	"	"	2.88E-03
15	"	"	"	"	"	3.05E-03
16	"	"	"	"	"	3.25E-03

### Thermal modeling

The thermal analysis are based on the design operating condition that includes both air and water flow. The boundary conditions for the 2D analysis use the temperature and film coefficients developed by Thermacore for their 1D thermal analysis which are tabulated below. The film coefficients are shown in W/m<sup>2</sup>K and (BTU/in<sup>2</sup> s F), temperatures in degF. The temperatures are representative of the conditions at the centerline of the cooler.

Section	T_air	T_water	hf_air	hf_water
1 <sup>st</sup> heat tube	908	85	478(1.62E-4)	8318 (2.83E-3)
1	833	88	478(1.62E-4)	8318 (2.83E-3)
2	658	96	473 (1.61E-4)	8318 (2.83E-3)
3	506	102	491 (1.67E-4)	8318 (2.83E-3)

Additionally the outside surface of the BAC losses heat by convection to the ambient air environment surrounding it. With the hot gas side temperatures being as high as they are, the outer surface of the BAC is assumed to be insulated. This effect is captured by using a reduced film coefficient that includes the insulation behavior.

The effective outer surface film coefficient is devised from the expression for thermal resistance. The terms  $t$  and  $k$  are the insulation thickness and conductivity, respectively. The term  $h_f$  is the film coefficient for the outer surface of the insulation. The term  $R_{contact}$  is the resistivity of the shell to insulation interface.

$$R = R_{contact} + \frac{t}{kA} + \frac{1}{h_f A}$$

The first term depends highly on the actual contact between the shell and insulation. For a good (touching) contact a resistivity of 1E-4 m<sup>2</sup>K/W is reasonable. For a poor (gapped) contact, the heat transfer changes to radiation making the resistance potentially very high.

The insulation is taken to be 2" of alumina-silica fiber blanket having a  $k=0.1$  W/mK making the second term equal to 0.5 m<sup>2</sup>K/W.

The third term corresponds to the cooling effect by the ambient air. Natural convection (stagnant air) values would be between 2-20 W/m<sup>2</sup>K. The resistivity is the reciprocal of this or, using 10 W/m<sup>2</sup>K, a resistivity of 0.1 m<sup>2</sup>K/W.

The net resistivity is taken as 1 m<sup>2</sup>K/W, or an upper bound film coefficient of 1 W/m<sup>2</sup>K.

### Pressure modeling

The pressure loads are applied normal to the surfaces of the shell and nozzles. An end load is also applied to the nozzle corresponding to a capped end condition.

Subject: BAC

Prepared by: *CS*

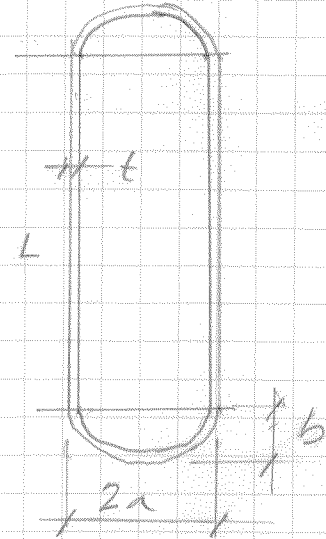
Gas ket area

Checked by:

Date: 5/11/04

Outer periphery  
rectangle  $2a \cdot L$   
ellipse  $+ 2\pi ab$

Inner periphery  
rectangle  $(2a - 2t) L$   
ellipse  $\pi(2a - 2t)(b - t)$



$$L = 58''$$

$$a = 7.875$$

$$b = (32.875 - 29'') = 3.875''$$

$$t = 3/4''$$

$$\text{outer area} = 2aL + 2\pi ab$$

$$1168 \text{ in}^2$$

$$\text{inner area} = (2a - 2t)L + \pi(2a - 2t)(b - t)$$

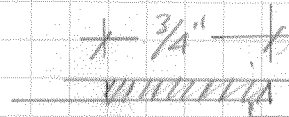
$$1023 \text{ in}^2$$

$$A_{\text{gasket, actual}} = 145 \text{ in}^2$$

$$N = 0.625''$$

$$N/2 = 0.3125'' = b_0$$

$$b = \frac{\sqrt{b_0}}{2} = 0.28''$$



$$t = 1/8''$$

Subject: BAC

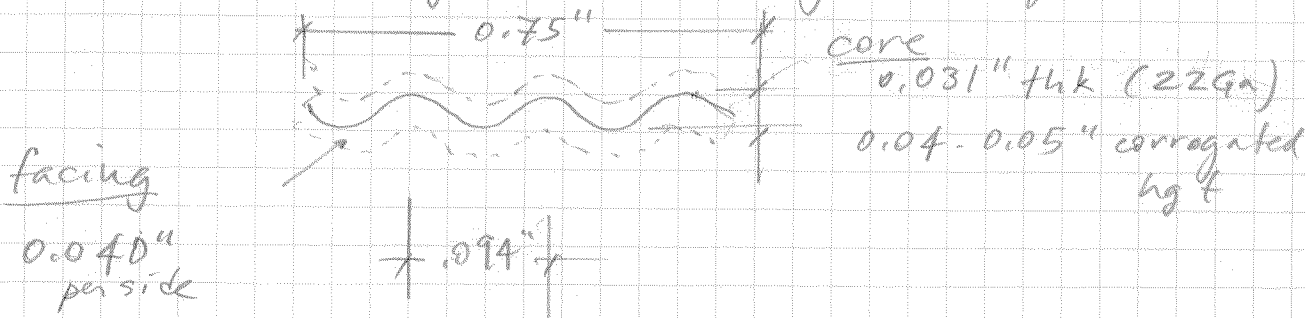
Prepared by: CB

Checked by:

Date: 5/11/04

Gasket/bolt interaction

Garlock - Style 601 Corragraph gasket



ASME Sect. VIII, Div. 1, App. 2 factors

$$m = 9$$

$$y = 3000 \text{ psi}$$

For gasket seating 2-5(c)(2)

eqn 2:  $W_{m2} = 3.14 b G y$

$b = \text{effective width} = 0.28"$

$3.14 G = \pi D = \text{circle length w/ dia of gasket dia.}$

$y = \text{gasket seating load}$

$\therefore W_{m2} = A_{\text{gasket}} \times y$

$A_{\text{gasket}} = A_{\text{actual}} \left( \frac{0.28}{0.75} \right) = 54.13 \text{ in}^2$

$\times 3000 \text{ psi}$

$162400 \text{ \#}$

$\div 62 \text{ bolts}$

$2620 \text{ \#}$

Subject: BAC

Prepared by: CB

Flange - bolting

Checked by:

Date: 5/11/04

Bolting

Operating condition 3394 #/bolt

1/2"  $\phi$  bolt,  $A = 0.126 \text{ in}^2$

$$\sigma = \frac{P}{A} = 26.9 \text{ ksi} \quad \text{No good}$$

5/8"  $\phi$  bolt,  $A = 0.202 \text{ in}^2$

$$\sigma = 16.8 \text{ ksi}$$

need 75 ksi UTS Monel

bolts SB-164, N04400

67Ni-30Cu

S = 20 ksi up to  $\approx 500^\circ\text{F}$

Subject: BAC

Prepared by: CB

Flange - ops

Checked by:

Date: 5/11/04

for 0.625"

$$S = \frac{(0.625")^2}{6} = 0.0651 \text{ in}^3$$

$$\sigma_b = \frac{1236}{0.0651} = 19.0 \text{ ksi}$$

$$S_{min} = \frac{19.0}{1.5} = 12.6 \text{ ksi}$$

for 70/30 200°F max

for 304,  $T_{max} \approx 550^\circ\text{F}$ , No gird

for 0.75"

$$S = 0.09375 \text{ in}^3$$

$$\sigma_b = \frac{1236 \text{ #/in}^2}{0.09375 \text{ in}^3} = 13.2 \text{ ksi}$$

$$S_{min} = \frac{13.2}{1.5} = 8.8 \text{ ksi ok for both}$$



Subject: BAC

Prepared by: CB

Checked by: \_\_\_\_\_

Date: 5/11/04

Flange ops

operations 2-5(c)(1)

$$W_{ml} = 0.785 G^2 P + 2b \times 3.14 G m P$$

$$0.785 G^2 = \frac{\pi G^2}{4} + A_{\text{gasket}, 2b} \times m P$$

area within gasket x pressure  
midline

for BAC

$$A_{\text{within gasket}} = 1095 \text{ in}^2$$

midline

$$\times 100 \text{ psi}$$

$$109500 \#$$

$$A_{\text{gasket, actual}} = 108.3 \text{ in}^2 = \frac{2(0.25)}{0.75} \times 145$$

$$\times 9 \times 100$$

$$97440$$

$$\text{gasket load, total } 206,940 = W_{ml}$$

$$\frac{206,940}{62} = 3338 \#/\text{bolt} = 1236 \#/\text{inch}$$

$$M = P \cdot e \quad e = 1"$$

$$M = 1236 \#/\text{inch}$$

Subject: BAC

Prepared by: CB

Checked by: \_\_\_\_\_

Date: 5/11/04

Flange - ops

for 0.875" thick

$$S = \frac{(0.875)^2}{6} = 0.1276 \text{ in}^3$$

$$\sigma_b = \frac{M}{S} = \frac{970 \text{ in} \cdot \text{lb}}{0.1276 \text{ in}^3} = 10.9 \text{ ksi} \leq 11.5 \text{ S}$$

$$S_{\text{min}} = 7.3 \text{ ksi}$$

for 70/30, ok up to limit T of 700°F

for 304,  $T_{\text{max}} \approx 1150^\circ\text{F}$

for 0.75" thick

$$S = \frac{(0.75)^2}{6} = 0.09375$$

$$\sigma_b = 14.8 \text{ ksi}$$

$$S_{\text{min}} = 9.9 \text{ ksi}$$

for 70/30, ok up to limit T of 700°F

for 304,  $T_{\text{max}}$  slightly  $< 1100^\circ\text{F}$

Subject: BAC

Prepared by: CS

Flange-seating

Checked by: \_\_\_\_\_

Date: 5/11/94

$$t_{req'd} = \sqrt{\frac{6M}{\sigma_{max}}} \quad \sigma_{max} = 1.5S$$

$$S_{304, ambient} = 20 \text{ ksi.}$$

$$S_{70/30, ambient} = 13.3 \text{ ksi.}$$

$$t_{req'd} \text{ 304} = 0.44''$$

$$t_{req'd} \text{ 70/30} = 0.54''$$

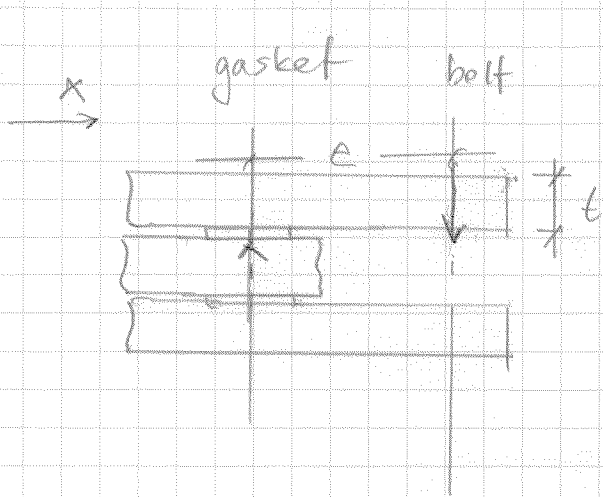
Subject: BAC

Prepared by: CB

Checked by:

Date: 5/11/04

Flange sizing - straight section



gasket seating  
 $W_{m2} = 2620 \text{ \#}$

$$\text{Bolt spacing} = 2L + \pi \frac{a+b}{4} \left( 3(1-\lambda) + \frac{1}{1-\lambda} \right)$$

$a = 9''$   
 $b = 5''$

$$\lambda = \left( \frac{a-b}{2(a+b)} \right)^2$$

$$= \frac{167.5''}{62} = 2.70''$$

Bolt load per unit width of flange

$$P = 2620 \text{ \#} / 2.7'' = 970 \text{ \#/''}$$

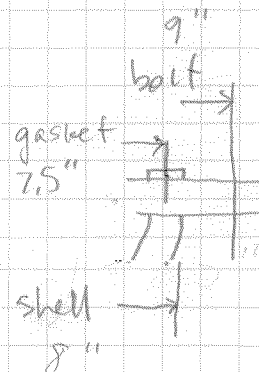
Moment per unit width

$$M = P \cdot e$$

$$e = X_{\text{bolt}} - X_{\text{shell}}$$

$$e = 1''$$

$$M = 970 \text{ \#} \times 1'' = 970 \text{ \#/per inch}$$



Subject: BAC

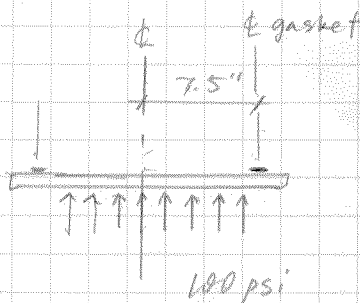
Prepared by: CM

tube sheet

Checked by:

Date: 5/11/04

Check of tube sheet



$$M = \frac{wl^2}{8} \quad l = 15" \quad w = 100 \#/"$$

$$M = 2813 \#/"$$

$$\sigma_b = \frac{M}{S} = \frac{1}{\eta} \frac{6M}{t^2}$$

$$\eta = \text{ligament efficiency} = \frac{p-d}{p} = 0.53$$

$$\frac{1}{\eta} = 1.88$$

$$\sigma_b = \frac{6 \cdot 2813 \#/"}{0.53 t^2}$$

$$\text{or } t = \sqrt{\frac{31731}{\sigma_b}}$$

$$\sigma_{b, \max} = 1.5S$$

MDMT	S	t req'd
250°F	12.3 ksi	1.31"
300°F	12.0	1.33"
350°F	11.7	1.34"

using  $l$  based on inner edge of gasket,  $l = 14.25"$

300 F 1.26"

Subject: BAC

Prepared by: CB

Checked by:

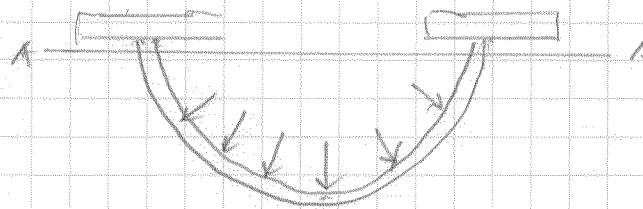
Date: 5/11/04

shell hoop

Check of shell

Free-body @ A-A

use eqns for  
area of gasket



$$2aL + 2\pi a b \quad \text{outer} \quad - \quad \left[ (2a-2t)L + \pi (2a-2t)(b-t) \right] \quad \text{inner}$$

$$2a = 16''$$

$$t = 0.5''$$

$$L = 62''$$

$$b = 4''$$

Area of shell

$$1193 \text{ in}^2 \quad \text{outer}$$

inner

$$1095 \text{ in}^2$$

$$= 98 \text{ in}^2$$

$$\text{Load} = 100 \text{ psi} \times 1095 \text{ in}^2 = 109,500 \text{ lb}$$

$$\text{Stress} = \frac{P}{A} = 1116 \text{ psi} \ll S \quad \frac{0.6}{3}$$

## **Appendix A-F**

### **Thermal Analysis Models**

## NSWC Bleed Air Cooler Thermal Design and Analysis GV0137 Test Data Conditions, No Fouling

### NOTES

1. Begun by Kevin Wert, 14 July 1999
2. Heat exchanger configuration: single-pass, parallel flow.
3. Pipe array configuration: equilateral triangles.
4. Exchanger composed of  $N_{core}$  number of individual core modules in series; each module may feature a unique number of fins and fin thicknesses on both condenser and evaporator sides.
5. 17 August 1999: Added a condenser-side fouling factor.
6. 25 August 1999: Added an evaporator-side fouling factor.
7. 2 September 1999: Fluid properties can be set independently for each core module.
8. 3 September 1999: Modified condenser-side fin efficiency, heat transfer coefficient and pressure drop for circular fins on circular tubes.
9. Changed Thermosyphon Linear Resistance from 0.06 to 0.07 in light of experimental data.
10. 25 May 2004: Revised to Reflect Prototype Geometry (Baffles).
11. 10 May 2004: Revised to Reflect Prototype Geometry (Fin Count).

### HEAT PIPE ARRAY

#### Geometry

$$m := 1..N_{core}$$

$$CoreModuleLength := \frac{Length}{N_{core}}$$

$$Pitch_{pipe\_L} := \frac{CoreModuleLength}{N_{pipe\_L}} \quad \text{Pitch in the longitudinal direction:} \quad Pitch_{pipe\_L} = 0.039 \quad m$$

$$Pitch_{pipe\_W} := \frac{Width}{N_{pipe\_W}} \quad \text{Pitch in the transverse direction:} \quad Pitch_{pipe\_W} = 0.046 \quad m$$

$$N_{pipes} := N_{pipe\_L} \cdot N_{pipe\_W} \quad \text{Number of heat pipes per core module:} \quad N_{pipes} = 65$$

#### Linear Pipe Thermal Resistance Per Unit Length

$$R_{pipe} := \frac{R_{single\_heat\_pipe}}{N_{pipe\_W}} \cdot Pitch_{pipe\_L}$$

### CONDENSER-SIDE HEAT TRANSFER: Circular Fins

#### Geometry

$$FinPitch_{cond\_m} := \frac{1}{FinDens_{cond\_m}}$$



$$N_{fins\_cond\_m} := \text{floor}(\text{FinDens}_{cond\_m} \cdot \text{Height}_{cond}) \quad \text{Number of fins per pipe on the condenser side: } N_{fins\_cond\_m} = \begin{pmatrix} 11 \\ 11 \\ 11 \end{pmatrix}$$

$$\text{FinHeight}_{cond\_m} := \frac{\text{FinOD}_{cond\_m} - d_{pipe}}{2}$$

$$\text{FinSurfArea}_{cond\_m} := N_{pipes} \cdot N_{fins\_cond\_m} \cdot \left[ \frac{2 \cdot \pi}{4} \cdot \left[ (\text{FinOD}_{cond\_m})^2 - d_{pipe}^2 \right] + \pi \cdot \text{FinOD}_{cond\_m} \cdot \text{FinThickness}_{cond\_m} \right]$$

$$\text{PipeSurfArea}_{cond\_m} := \pi \cdot d_{pipe} \cdot \text{Height}_{cond} \cdot \left( 1 - \text{FinThickness}_{cond\_m} \cdot \text{FinDens}_{cond\_m} \right) \cdot N_{pipe}$$

$$\text{TotalSurfArea}_{cond\_m} := \text{FinSurfArea}_{cond\_m} + \text{PipeSurfArea}_{cond\_m} \quad \text{Total surface area on the condenser side: } \sum_m \text{TotalSurfArea}_{cond\_m} = 3.037 \text{ m}^2$$

$$\text{MinFlowArea}_{cond\_plaintubesXXX\_m} := (\text{Pitch}_{pipe\_W} - d_{pipe}) \cdot \text{Height}_{cond} \cdot N_{pipe\_W} \quad \text{(Disabled)}$$

$$\text{MinFlowArea}_{cond\_plaintubes\_m} := \text{ShellBaffle\_Width}_{cond} \cdot \text{ShellBaffle\_Height}_{cond} - d_{pipe} \cdot \text{Height}_{cond} \cdot N_{pipe\_W}$$

$$\text{MinFlowArea}_{cond\_circfinsXXX\_m} := (\text{Pitch}_{pipe\_W} - d_{pipe} - 2 \cdot \text{FinHeight}_{cond\_m} \cdot \text{FinThickness}_{cond\_m} \cdot \text{FinDens}_{cond\_m}) \cdot \text{Height}_{cond} \cdot N_{pipe\_W} \quad \text{(Disabled)}$$

$$\text{MinFlowArea}_{cond\_circfins\_m} := \text{ShellBaffle\_Width}_{cond} \cdot \text{ShellBaffle\_Height}_{cond} \dots + -(d_{pipe} + 2 \cdot \text{FinHeight}_{cond\_m} \cdot \text{FinThickness}_{cond\_m} \cdot \text{FinDens}_{cond\_m}) \cdot \text{Height}_{cond} \cdot N_{pipe\_W}$$

Heat Transfer Correlations:

Plain Tube Banks--Zhukauskas (1972)

$$\text{MassVelocity}_{cond\_plaintubes\_m} := \frac{M_{coolant}}{\text{MinFlowArea}_{cond\_plaintubes\_m}}$$

$$\text{Re}_{cond\_plaintubes\_m} := \frac{\text{MassVelocity}_{cond\_plaintubes\_m} \cdot d_{pipe}}{\mu_{coolant\_m}} \quad \text{Plain-Tube Reynolds Number: } \text{Re}_{cond\_plaintubes\_m} \begin{pmatrix} 1.891 \times 10^4 \\ 1.891 \times 10^4 \\ 1.891 \times 10^4 \end{pmatrix}$$

$$\text{Nu}_{cond\_plaintubes\_m} := 0.35 \cdot (\text{Re}_{cond\_plaintubes\_m})^{0.6} \cdot \left( \frac{\text{Pitch}_{pipe\_W}}{\text{Pitch}_{pipe\_L}} \right)^{0.2} \cdot (\text{Pr}_{coolant\_m})^{0.36}$$

$$h_{cond\_plaintubes\_m} := \frac{\text{Nu}_{cond\_plaintubes\_m} \cdot k_{coolant\_t}}{d_{pipe}}$$

**Individual Circular Fins--Briggs and Young (1963)**

$$\text{MassVelocity}_{\text{cond\_circfins}_m} := \frac{M_{\text{coolant}}}{\text{MinFlowArea}_{\text{cond\_circfins}_m}} \quad \left( \frac{\text{MassVelocity}_{\text{cond\_circfins}_m}}{\rho_{\text{coolant}_m}} \right) \begin{matrix} 0.749 \\ 0.749 \\ 0.749 \end{matrix}$$

$$\text{Re}_{\text{cond\_circfins}_m} := \frac{\text{MassVelocity}_{\text{cond\_circfins}_m} \cdot d_{\text{pipe}}}{\mu_{\text{coolant}_m}} \quad \text{Plain-Tube Reynolds Number: } \text{Re}_{\text{cond\_circfins}_m} = \begin{matrix} 2.017 \times 10^4 \\ 2.017 \times 10^4 \\ 2.017 \times 10^4 \end{matrix}$$

$$j_{\text{cond\_circfins}_m} := 0.134 \cdot (\text{Re}_{\text{cond\_circfins}_m})^{-0.319} \cdot \left( \frac{\text{FinPitch}_{\text{cond}_m} - \text{FinThickness}_{\text{cond}_m}}{\text{FinHeight}_{\text{cond}_m}} \right)^{0.2} \cdot \left( \frac{\text{FinPitch}_{\text{cond}_m} - \text{FinThickness}_{\text{cond}_m}}{\text{FinThickness}_{\text{cond}_m}} \right)^{0.11}$$

$$\text{St}_{\text{cond\_circfins}_m} := \frac{j_{\text{cond\_circfins}_m}}{\frac{2}{(\text{Pr}_{\text{coolant}_m})^3}}$$

$$h_{\text{cond\_circfins}_m} := \text{St}_{\text{cond\_circfins}_m} \cdot \text{MassVelocity}_{\text{cond\_circfins}_m} \cdot c_{p\_coolant_m}$$

$$h_{\text{cond}_m} := \begin{cases} h_{\text{cond\_plaintubes}_m} & \text{if } h_{\text{cond\_plaintubes}_m} < h_{\text{cond\_circfins}_m} \\ h_{\text{cond\_circfins}_m} & \text{otherwise} \end{cases}$$

The heat transfer coefficient is taken to be the minimum of the value for plain staggered tube banks or the value for staggered tube banks with circular fins. This is a conservative choice.

**Surface Effectiveness**

$$a_{\text{cond}_m} := \frac{d_{\text{pipe}}}{\text{FinOD}_{\text{cond}_m}} \quad b_{\text{cond}_m} := \frac{\text{FinThickness}_{\text{cond}_m}}{\text{FinOD}_{\text{cond}_m}} \quad M_{\text{cond}_m} := \sqrt{\frac{h_{\text{cond}_m} \cdot (\text{FinOD}_{\text{cond}_m})^2}{2 \cdot k_{\text{fin\_cond}_m} \cdot \text{FinThickness}_{\text{cond}_m}}}$$

$$\text{term1}_{\text{cond}_m} := K1(M_{\text{cond}_m}) - \frac{b_{\text{cond}_m} \cdot M_{\text{cond}_m}}{2} \cdot K0(M_{\text{cond}_m})$$

$$\text{term2}_{\text{cond}_m} := I1(M_{\text{cond}_m}) + \frac{b_{\text{cond}_m} \cdot M_{\text{cond}_m}}{10} \cdot I0(M_{\text{cond}_m})$$

$$C_{\text{cond}_m} := \frac{\text{term1}_{\text{cond}_m}}{I0(M_{\text{cond}_m} \cdot a_{\text{cond}_m}) \cdot \text{term1}_{\text{cond}_m} + K0(M_{\text{cond}_m} \cdot a_{\text{cond}_m}) \cdot \text{term2}_{\text{cond}_m}}$$

$$C_{cond2_m} := \frac{term2_{cond_m}}{10(M_{cond_m} \cdot a_{cond_m}) \cdot term1_{cond_m} + K0(M_{cond_m} \cdot a_{cond_m}) \cdot term2_{cond_m}}$$

$$FinEfficiency_{cond_m} := 2 \cdot \frac{-C_{cond1_m} \cdot II(M_{cond_m} \cdot a_{cond_m}) + C_{cond2_m} \cdot K1(M_{cond_m} \cdot a_{cond_m})}{\left[ \frac{1 - (a_{cond_m})^2}{a_{cond_m}} + b_{cond_m} \right] M_{cond_m}}$$

Condenser-side fin efficiency:  $FinEfficiency_{cond_m} = \begin{pmatrix} 0.367 \\ 0.367 \\ 0.367 \end{pmatrix}$

$$SurfaceEffect_{cond_m} := 1 - \left( 1 - FinEfficiency_{cond_m} \right) \cdot \frac{FinSurfArea_{cond_m}}{TotalSurfArea_{cond_m}}$$

Condenser-side surface effectiveness:  $SurfaceEffect_{cond_m} = \begin{pmatrix} 0.575 \\ 0.575 \\ 0.575 \end{pmatrix}$

$$R_{cond_m} := \frac{CoreModuleLength}{h_{cond_m} \cdot TotalSurfArea_{cond_m} \cdot SurfaceEffect_{cond_m}}$$

$$R_{cond\_foul_m} := \frac{R_{cond\_fouling\_factor} \cdot CoreModuleLength}{TotalSurfArea_{cond_m} \cdot SurfaceEffect_{cond_m}}$$

Condenser-side resistance per unit length:  $R_{cond_m} + R_{cond\_foul_m} = \begin{pmatrix} 1.234 \times 10^{-4} \\ 1.234 \times 10^{-4} \\ 234 \times 10^{-4} \end{pmatrix}$

**EVAPORATOR-SIDE HEAT TRANSFER**

C/(watt/m)

Geometry

$$FinPitch_{evap_m} := \frac{CoreModuleLength}{FinDens_{evap_m}}$$

$$N_{fins\_evap_m} := floor( FinDens_{evap_m} \cdot Height_{evap} )$$

Number of fins per pipe on the evaporator side:  $N_{fins\_evap_m} = \begin{pmatrix} 53 \\ 53 \\ 53 \end{pmatrix}$

$$FinHeight_{evap_m} := \frac{FinHex_{evap_m} - d_{pipe}}{2}$$

$$FinSurfArea_{evapXXX_m} := \left( CoreModuleLength \cdot Width - N_{pipes} \cdot \pi \cdot \frac{d_{pipe}^2}{4} \right) \cdot 2 \cdot N_{fins\_evap_m}$$

(Disabled)

$$FinSurfArea_{evap_m} := 2 \cdot N_{pipes} \cdot N_{fins\_evap_m} \cdot \left[ 6 \cdot \left( \frac{FinHex_{evap_m}}{2} \right)^2 \cdot \tan\left(\frac{\pi}{6}\right) - \frac{\pi}{4} \cdot d_{pipe}^2 \right]$$

Hexagonal Fins

$$PipeSurfArea_{evap_m} := \pi \cdot d_{pipe} \cdot Height_{evap} \cdot \left( 1 - FinThickness_{evap_m} \cdot FinDens_{evap_m} \right) \cdot N_{pipes}$$

$$\text{TotalSurfArea}_{\text{evap}_m} := \text{FinSurfArea}_{\text{evap}_m} + \text{PipeSurfArea}_{\text{evap}_m} \quad \text{Total surface area on the evaporator side: } \sum_m \text{TotalSurfArea}_{\text{evap}_m} = 27.675 \text{ m}^2$$

$$\text{MinFlowArea}_{\text{evapXXX}_m} := (\text{Pitch}_{\text{pipe}_W} - d_{\text{pipe}}) \cdot \text{Height}_{\text{evap}} \cdot (1 - \text{FinThickness}_{\text{evap}_m} \cdot \text{FinDense}_{\text{evap}_m}) \cdot N_{\text{pipe}_W} \quad (\text{Disabled})$$

$$\text{MinFlowArea}_{\text{evap}_m} := \text{ShellBaffle\_Width}_{\text{evap}} \cdot \text{ShellBaffle\_Height}_{\text{evap}} \dots + (d_{\text{pipe}} + 2 \cdot \text{FinHeight}_{\text{evap}_m} \cdot \text{FinThickness}_{\text{evap}_m} \cdot \text{FinDense}_{\text{evap}_m}) \cdot \text{Height}_{\text{evap}} \cdot N_{\text{pipe}_W}$$

**Heat Transfer Correlation: From Webb "Principles of Heat Transfer (1994)**

$$\text{MassVelocity}_{\text{evap}_m} := \frac{M_{\text{hotfluid}}}{\text{MinFlowArea}_{\text{evap}_m}}$$

$$\text{Re}_{\text{evap}_m} = \frac{\text{MassVelocity}_{\text{evap}_m} \cdot d_{\text{pipe}}}{\mu_{\text{hotfluid}_m}} \quad \text{Evaporator-side Reynolds Number: } \text{Re}_{\text{evap}_m} \begin{pmatrix} 7.543 \times 10^4 \\ 7.543 \times 10^4 \\ 7.543 \times 10^4 \end{pmatrix}$$

$$j_{\text{evap}_m} := 0.14 \cdot (\text{Re}_{\text{evap}_m})^{-0.328} \cdot \left( \frac{\text{Pitch}_{\text{pipe}_W}}{\text{Pitch}_{\text{pipe}_L}} \right)^{-0.502} \cdot \left( \frac{\text{FinPitch}_{\text{evap}_m} - \text{FinThickness}_{\text{evap}_m}}{d_{\text{pipe}}} \right)^{0.031}$$

$$\text{St}_{\text{evap}_m} := \frac{j_{\text{evap}_m}}{\left( \text{Pr}_{\text{hotfluid}_m} \right)^{\frac{2}{3}}}$$

$$h_{\text{evap}_m} := \text{St}_{\text{evap}_m} \cdot \text{MassVelocity}_{\text{evap}_m} \cdot c_{p\_hotfluid_n}$$

**Surface Effectiveness**

$$\text{FinEfficiency}_{\text{evap}_m} := \frac{\tanh \left[ \left( \frac{2 \cdot h_{\text{evap}_m}}{k_{\text{fin\_evap}} \cdot \text{FinThickness}_{\text{evap}_m}} \right)^{0.5} \cdot \text{FinHeight}_{\text{evap}_m} \right]}{\left( \frac{2 \cdot h_{\text{evap}_m}}{k_{\text{fin\_evap}} \cdot \text{FinThickness}_{\text{evap}_m}} \right)^{0.5} \cdot \text{FinHeight}_{\text{evap}_m}}$$

$$\text{SurfaceEffect}_{\text{evap}_m} := \left( 1 - \text{FinEfficiency}_{\text{evap}_m} \right) \cdot \frac{\text{FinSurfArea}_{\text{evap}_m}}{\text{TotalSurfArea}_{\text{evap}_m}} \quad \text{Evaporator-side surface effectiveness: } \text{SurfaceEffect}_{\text{evap}_m} = \begin{pmatrix} 0.716 \\ 0.716 \\ 0.716 \end{pmatrix}$$

$$:= \frac{\text{CoreModuleLength}}{h_{\text{evap}_m} \cdot \text{TotalSurfArea}_{\text{evap}_m} \cdot \text{SurfaceEffect}_{\text{evap}_m}}$$

$$R_{\text{evap\_foul}_m} := \frac{R_{\text{evap\_fouling\_factor}} \cdot \text{CoreModuleLength}}{\text{TotalSurfArea}_{\text{evap}_m} \cdot \text{SurfaceEffect}_{\text{evap}_m}}$$

Evaporator-side resistance per unit length:  $R_{\text{evap}_m} + R_{\text{evap\_foul}_m} = 2.095 \times 10^{-4}$   
 $2.095 \times 10^{-4}$   
 C/(watt/m)

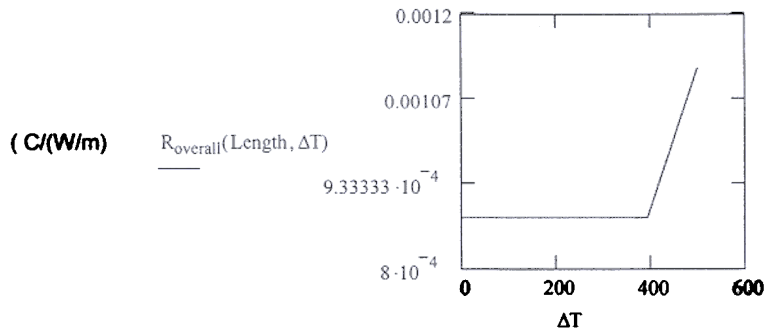
**OVERALL THERMAL RESISTANCE OF THE HEAT EXCHANGER PER UNIT LENGTH**

$$:= R_{\text{cond}_m} + R_{\text{pipe}} + R_{\text{evap}_m} + R_{\text{cond\_foul}_m} + R_{\text{evap\_foul}_m}$$

$$M(x) := \text{if} \left( \text{floor} \left( \frac{x}{\text{CoreModuleLength}} \right) + 1 \leq N_{\text{core}}, \text{floor} \left( \frac{x}{\text{CoreModuleLength}} \right) + 1, \text{floor} \left( \frac{x}{\text{CoreModuleLength}} \right) \right)$$

$$R_{\text{overall}}(x, \Delta T) := \begin{cases} R_{\text{linear}_{M(x)}} & \text{if } \frac{\Delta T}{R_{\text{linear}_{M(x)}}} \leq \frac{N_{\text{pipe}} \cdot W \cdot Q_{\text{flooding\_limit}}}{\text{Pitch}_{\text{pipe\_L}}} \\ \frac{\Delta T}{\dots} & \text{otherwise} \end{cases} \quad \text{Nonlinear resistance}$$

$\Delta T \approx 0, \quad 500$



**SOLVE FOR THE FLUID TEMPERATURE PROFILES**

$$C_{\text{hotfluid}}(x) := M_{\text{hotfluid}} \cdot c_{p\_hotfluid\_M(x)}$$

$$C_{\text{coolant}}(x) := M_{\text{coolant}} \cdot c_{p\_coolant\_M(x)}$$

$$T := \begin{matrix} T_{\text{hotfluid\_in}} \\ T_{\text{coolant\_in}} \end{matrix} \quad \text{Inlet temperatures}$$

$$dT(x, T) := \frac{\frac{T_0 - T_1}{C_{\text{hotfluid}}(x) \cdot R_{\text{overall}}(x, T_0 - T_1)}}{\frac{T_0 - T_1}{C_{\text{coolant}}(x) \cdot R_{\text{overall}}(x, T_0 - T_1)}} \quad \text{First derivatives of the fluid temperatures}$$

$$Temp := \text{rkfixed}(T, 0, \text{Length}, N_{\text{core}} \cdot N_{\text{pipe\_L}}, dT) \quad \text{Fourth-order Runge-Kutta scheme for } T(x)$$

**TOTAL AND LOCAL HEAT TRANSFER RATES**

$$Q_{\text{evap}} := \sum_{m=1}^{N_{\text{core}}} M_{\text{hotfluid}} \cdot c_{p\_hotfluid\_m} \left[ \text{Temp}_{(m-1) \cdot N_{\text{pipe\_L}}, 1} - \text{Temp}_{m \cdot N_{\text{pipe\_L}}, 1} \right] \quad \text{Total heat transfer rate on the evaporator side:}$$

$$Q_{\text{evap}} = 2.064 \times 10^5 \text{ atts}$$

$$Q_{\text{cond}} := \sum_{m=1}^{N_{\text{core}}} M_{\text{coolant}} \cdot c_{p\_coolant\_m} \left[ \text{Temp}_{m \cdot N_{\text{pipe\_L}}, 2} - \text{Temp}_{(m-1) \cdot N_{\text{pipe\_L}}, 2} \right] \quad \text{Check: Total heat transfer rate on the condenser side:}$$

$$Q_{\text{cond}} = 2.064 \times 10^5 \text{ atts}$$

$$n := N_{\text{core}} \cdot N_{\text{pipe\_L}}$$

$$x_n := \text{Length} \cdot \frac{n}{N_{\text{core}} \cdot N_{\text{pipe\_L}}}$$

$$q_n := \frac{\text{Temp}_{n, 1} - \text{Temp}_{n, 2}}{\frac{N_{\text{pipe\_w}} \cdot R_{\text{overall}}(x_n, \text{Temp}_{n, 1} - \text{Temp}_{n, 2})}{\text{Pitch}_{\text{pipe\_L}}}} \quad \text{Local heat transfer rate per heat pipe for each transverse row of heat pipes.}$$

**RESISTANCE CONTRIBUTIONS**

$$\Delta T_{\text{evap}_n} := \frac{(R_{\text{evap}_M(x_n)} + R_{\text{evap\_foul}_M(x_n)}) \cdot (\text{Temp}_{n,1} - \text{Temp}_{n,2})}{R_{\text{overall}}(x_n, \text{Temp}_{n,1} - \text{Temp}_{n,2})}$$

Contribution of the evaporator-side  $\Delta T$  to the overall  $\Delta T$ .

$$\Delta T_{\text{cond}_n} := \frac{(R_{\text{cond}_M(x_n)} + R_{\text{cond\_foul}_M(x_n)}) \cdot (\text{Temp}_{n,1} - \text{Temp}_{n,2})}{R_{\text{overall}}(x_n, \text{Temp}_{n,1} - \text{Temp}_{n,2})}$$

Contribution of the condenser-side  $\Delta T$  to the overall  $\Delta T$ .

$$\Delta T_{\text{pipes}_n} := \text{Temp}_{n,1} - \text{Temp}_{n,2} - \Delta T_{\text{evap}_n} - \Delta T_{\text{cond}_n}$$

Contribution of the heat pipe  $\Delta T$  to the overall  $\Delta T$ .

**HEAT PIPE O.D. WALL TEMPERATURES**

$$T_{\text{evap\_wall}_n} := \text{Temp}_{n,1} - \Delta T_{\text{evap}_n}$$

Evaporator wall temperature

$$T_{\text{cond\_wall}_n} := \text{Temp}_{n,2} + \Delta T_{\text{cond}_n}$$

Condenser wall temperature.

**CONDENSER-SIDE PRESSURE DROP**

Based on Roshenow et al. "Handbook of Heat Transfer Applications" (1985)

Individually Circular Finned Tubes:

Robinson and Briggs correlation (1966)

$$\Delta P_{\text{cond}_m} := N_{\text{pipe}_L} \cdot \frac{4 \cdot (\text{MassVelocity}_{\text{cond\_circfins}_m})^2}{2 \cdot \rho_{\text{coolant}_m}} \cdot 9.465 \cdot (\text{Re}_{\text{cond\_circfins}_m})^{-0.316} \left( \frac{\text{Pitch}_{\text{pipe}_W}}{d_{\text{pipe}}} \right)^{-0.937}$$

Inlet/Outlet Losses:

Handbook of Fluid Dynamics (1981)

$$\text{Velocity}_{\text{cond\_inlet}} := \frac{M_{\text{coolant}}}{\rho_{\text{coolant}_1} \cdot \frac{\pi}{4} \cdot \text{ID}_{\text{cond\_inlet}}^2}$$

$$\Delta P_{\text{cond\_inlet}} := K_{\text{cond\_inlet}} \cdot \frac{1}{2} \cdot \rho_{\text{coolant}_1} \cdot \text{Velocity}_{\text{cond\_inlet}}^2$$

$$\text{Velocity}_{\text{cond\_outlet}} := \frac{M_{\text{coolant}}}{\rho_{\text{coolant}_{N_{\text{core}}}} \cdot \frac{\pi}{4} \cdot \text{ID}_{\text{cond\_outlet}}^2}$$

$$\Delta P_{\text{cond\_outlet}} := K_{\text{cond\_outlet}} \cdot \frac{1}{2} \cdot \rho_{\text{coolant}_{N_{\text{core}}}} \cdot \text{Velocity}_{\text{cond\_outlet}}^2$$

**EVAPORATOR-SIDE PRESSURE DROP**

Based on Webb "Principles of Enhanced Heat Transfer" (1994)

Fin Contribution

$$f_{\text{evap\_fin}_m} := 0.508 \cdot (Re_{\text{evap}_m})^{-0.521} \left( \frac{\text{Pitchpipe}_W}{d_{\text{pipe}}} \right)^{1.318}$$

$$\Delta P_{\text{cvap\_fin}_m} := \frac{f_{\text{evap\_fin}_m}}{2 \cdot \rho_{\text{hotfluid}_m}} \cdot (\text{MassVelocity}_{\text{evap}_m})^2 \cdot \frac{\text{FinSurfArea}_{\text{evap}_m}}{\text{MinFlowArea}_{\text{evap}_m}} \cdot f_{\text{cvap\_fin}_m}$$

Plain Pipe Contribution:

Based on A. Zukauskas "High-Performance, Single-Phase Heat Exchangers" (1989)

$$a_{\text{cvap}} := \frac{\text{Pitchpipe}_W}{d_{\text{pipe}}}$$

$$Eu_{\text{evap}_m} := \begin{cases} 2.6 \cdot (a_{\text{cvap}} - 1)^{-0.25} \cdot (Re_{\text{evap}_m})^{-0.29} & \text{if } Re_{\text{evap}_m} \geq 7 \cdot 10^3 \\ 0.71 \cdot (a_{\text{cvap}} - 1)^{-0.33} \cdot (Re_{\text{evap}_m})^{-0.15} & \text{otherwise} \end{cases}$$

$$\Delta P_{\text{evap\_pipe}_m} := Eu_{\text{evap}_m} \cdot \left[ \frac{(\text{MassVelocity}_{\text{evap}_m})^2}{\rho_{\text{hotfluid}_m}} \right] \cdot N_{\text{pipe}_L}$$

Module Total

$$\Delta P_{\text{cvap}_m} := \Delta P_{\text{cvap\_fin}_m} + \Delta P_{\text{cvap\_pipe}_m}$$

Inlet/Outlet Losses:

Handbook of Fluid Dynamics (1961)

$$\text{Velocity}_{\text{evap\_inlet}} := \frac{M_{\text{hotfluid}}}{\rho_{\text{hotfluid}_1} \cdot \frac{\pi}{4} \cdot ID_{\text{evap\_inlet}}^2}$$

$$\Delta P_{\text{evap\_inlet}} := K_{\text{evap\_inlet}} \cdot \frac{1}{2} \cdot \rho_{\text{hotfluid}_1} \cdot \text{Velocity}_{\text{evap\_inlet}}^2$$

$$\text{Velocity}_{\text{evap\_outlet}} := \frac{M_{\text{hotfluid}}}{\rho_{\text{hotfluid}_{N_{\text{core}}}} \cdot \frac{\pi}{4} \cdot ID_{\text{evap\_outlet}}^2}$$

$$\Delta P_{\text{evap\_outlet}} := K_{\text{evap\_outlet}} \cdot \frac{1}{2} \cdot \rho_{\text{hotfluid}_{N_{\text{core}}}} \cdot \text{Velocity}_{\text{evap\_outlet}}^2$$



**THERMAL PERFORMANCE METRICS**

**Total Cooler Surface Area**

$$A_{total} := \left( \sum_m TotalSurfArea_{cond_m} + \sum_m TotalSurfArea_{evap_m} \right)$$

**Cooler LMTD**

$$LMTD := \left[ \frac{(Temp_{0,1} - Temp_{0,2}) - (Temp_{N_{core} \cdot N_{pipe\_L},1} - Temp_{N_{core} \cdot N_{pipe\_L},2})}{\ln \left( \frac{Temp_{0,1} - Temp_{0,2}}{Temp_{N_{core} \cdot N_{pipe\_L},1} - Temp_{N_{core} \cdot N_{pipe\_L},2}} \right)} \right]$$

**Cooler UA**

$$U_{overall} := \frac{Q_{cool}}{A_{total} \cdot LMTD}$$

**DESIGN PARAMETERS: VALUES MUST BE GIVEN WITHOUT UNITS (REQUIRED UNITS INDICATED)**

**Exchanger Overall Dimensions**

Length = 1.524 (m)

Width = 0.229 (m)

**Heat Pipe**

N<sub>pipe\_L</sub> = 13

N<sub>pipe\_W</sub> = 5

d<sub>pipe</sub> = 2.1133 · 10<sup>-2</sup>

R<sub>single\_heat\_pipe</sub> = 0.07

Q<sub>flooding\_limit</sub> = 3500

Number of Thermosyphon Rows per Module

Number of Thermosyphons per Row

Heat pipe OD (m)

Linear resistance of a single heat pipe (C/watt)

Flooding limit of a single heat pipe (watt)

$$\frac{2}{2.54 \cdot 10^{-2}} = 78.74$$

$$\frac{3}{2.54 \cdot 10^{-2}} = 118.11$$

$$\frac{4}{2.54 \cdot 10^{-2}} = 157.48$$

$$\frac{5}{2.54 \cdot 10^{-2}} = 196.85$$

$$\frac{6}{2.54 \cdot 10^{-2}} = 236.2$$

$$\frac{10}{2.54 \cdot 10^{-2}} = 393.7$$

Number of Modules Comprising the Core

$N_{core} = 3$

Condenser Side

Evaporator Side

$ID_{cond\_inlet} = 0.0762$	(m)	$ID_{evap\_inlet} = 0.1016$	(m)
$ID_{cond\_outlet} = 0.0762$	(m)	$ID_{evap\_outlet} = 0.1016$	(m)
$K_{cond\_inlet} = 1$	(-, Sudden Expansion)	$K_{evap\_inlet} = 1$	(-, Sudden Expansion)
$K_{cond\_outlet} = 0.5$	(-, Sudden Contraction)	$K_{evap\_outlet} = 0.5$	(-, Sudden Contraction)
$ShellBaffle\_Width_{cond} = 0.248$	(m)	$ShellBaffle\_Width_{evap} = 0.248$	(m)
$ShellBaffle\_Height_{cond} = 0.0968$	(m)	$ShellBaffle\_Height_{evap} = 0.1365$	(m)
$Height_{cond} = 0.0952$	(Thermosyphon,m)	$Height_{evap} = 0.1349$	(Thermosyphon, m)
$FinDens_{cond_1} = 118.11$	( $m^{-1}$ )	$FinDens_{evap_1} = 393.701$	
$FinDens_{cond_2} = 118.11$	( $m^{-1}$ )	$FinDens_{evap_2} = 393.701$	( $m^{-1}$ )
$FinDens_{cond_3} = 118.11$	( $m^{-1}$ )	$FinDens_{evap_3} = 393.701$	( $m^{-1}$ )
$FinThickness_{cond_1} = 1.6 \cdot 10^{-3}$	(m)	$FinThickness_{evap_1} = 1.6 \cdot 10^{-3}$	(m)
$FinThickness_{cond_2} = 1.6 \cdot 10^{-3}$	(m)	$FinThickness_{evap_2} = 1.6 \cdot 10^{-3}$	(m)
$FinThickness_{cond_3} = 1.6 \cdot 10^{-3}$	(m)	$FinThickness_{evap_3} = 1.6 \cdot 10^{-3}$	(m)
$FinOD_{cond_1} = 3.0861 \cdot 10^{-2}$	(m)	$FinHex_{evap_1} = 0.04376$	(m)
$FinOD_{cond_2} = 3.0861 \cdot 10^{-2}$	(m)	$FinHex_{evap_2} = 0.04376$	(m)
$FinOD_{cond_3} = 3.0861 \cdot 10^{-2}$	(m)	$FinHex_{evap_3} = 0.04376$	(m)
$R_{cond\_fouling\_factor} = 0.0000$	( $m^2-C/W$ )	$Revap\_fouling\_factor = 0.0000$	( $m^2-C/W$ )
$k_{fin\_cond} = 43.9$	(W/m-C)	$k_{fin\_evap} = 43.9$	(W/m-C)
$\rho_{coolant_1} = 995.3$	( $kg/m^3$ )	$\rho_{hotfluid_1} = 4.332$	( $kg/m^3$ )
$\rho_{coolant_2} = 995.3$	( $kg/m^3$ )	$\rho_{hotfluid_2} = 4.332$	
$\rho_{coolant_3} = 995.3$	( $kg/m^3$ )	$\rho_{hotfluid_3} = 4.332$	( $kg/m^3$ )

$c_{p\_coolant_1} = 4180$	(joule/kg-C)	$c_{p\_hotfluid_1} = 1032$	(joule/kg-C)
$c_{p\_coolant_2} = 4180$	(joule/kg-C)	$c_{p\_hotfluid_2} = 1032$	(joule/kg-C)
$c_{p\_coolant_3} = 4180$	(joule/kg-C)	$c_{p\_hotfluid_3} = 1032$	(joule/kg-C)
$\mu_{coolant_1} = 780.7 \cdot 10^{-6}$	(N-sec/m <sup>2</sup> )	$\mu_{hotfluid_1} = 27.08 \cdot 10^{-6}$	(N-sec/m <sup>2</sup> )
$\mu_{coolant_2} = 780.7 \cdot 10^{-6}$	(N-sec/m <sup>2</sup> )	$\mu_{hotfluid_2} = 27.08 \cdot 10^{-6}$	(N-sec/m <sup>2</sup> )
$\mu_{coolant_3} = 780.7 \cdot 10^{-6}$	(N-sec/m <sup>2</sup> )	$\mu_{hotfluid_3} = 27.08 \cdot 10^{-6}$	(N-sec/m <sup>2</sup> )
$Pr_{coolant_1} = 5.288$	(-)	$Pr_{hotfluid_1} = 0.7170$	(-)
$Pr_{coolant_2} = 5.288$	(-)	$Pr_{hotfluid_2} = 0.7170$	(-)
$Pr_{coolant_3} = 5.288$	(-)	$Pr_{hotfluid_3} = 0.7170$	(-)
$k_{coolant_1} = \frac{\mu_{coolant_1} \cdot c_{p\_coolant_1}}{Pr_{coolant_1}}$	(watt/m-K)		
$k_{coolant_2} = \frac{\mu_{coolant_2} \cdot c_{p\_coolant_2}}{Pr_{coolant_2}}$	(watt/m-K)		
$k_{coolant_3} = \frac{\mu_{coolant_3} \cdot c_{p\_coolant_3}}{Pr_{coolant_3}}$	(watt/m-K)		
$M_{coolant} = 9.742$	(kg/sec)	$M_{hotfluid} = 0.965$	(kg/sec)
$T_{coolant\_in} = 29.08$	(C)	$T_{hotfluid\_in} = 284.33$	(C)

**RESULTS**

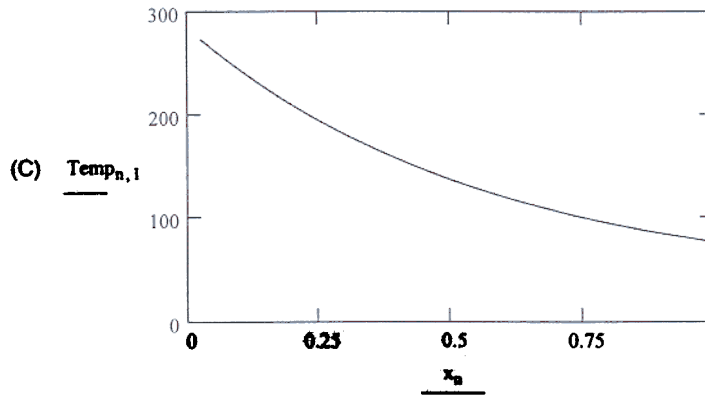
Total Number of Heat Pipes:  $N_{core} \cdot N_{pipe\_W} \cdot N_{pipe\_L} = 195$

Actual Longitudinal Pipe Pitch:  $Pitch_{pipe\_L} \cdot 39.370 = 1.538$  (in)

Actual Transverse Pipe Pitch:  $Pitch_{pipe\_W} \cdot 39.370 = 1.803$  (in)

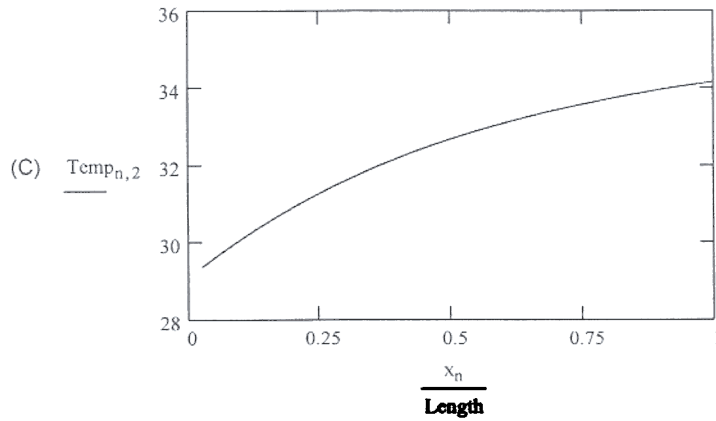
Length of each Core Module:  $CoreModuleLength \cdot 39.370 = 20$  (in)

**Evaporator-Side Temperature Profile vs. Normalized Exchanger Length**



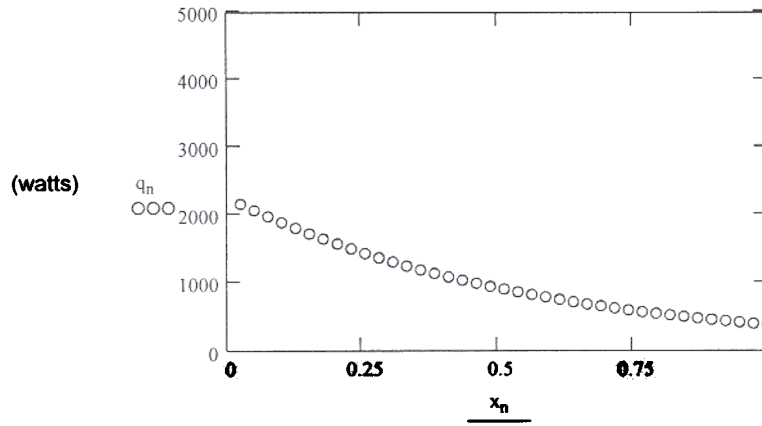
Total Evaporator-Side Heat Transfer Rate:  $Q_{\text{evap}} = 2.064 \times 10^5$  watts

**Condenser-Side Temperature Profile vs. Normalized Exchanger Length**

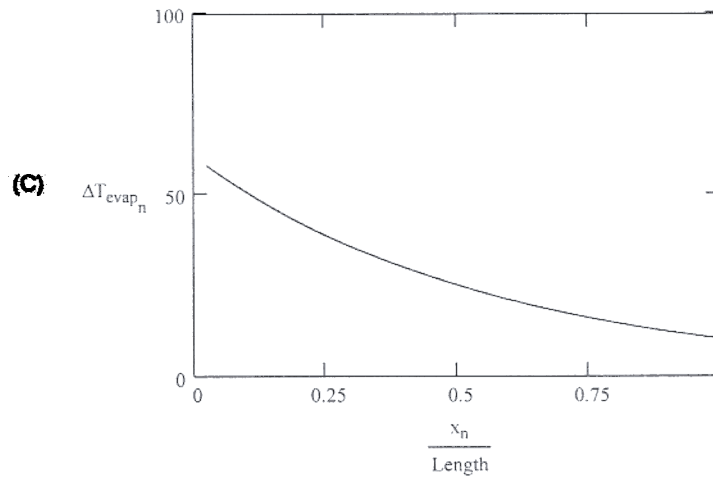


Total Condenser-Side Heat Transfer Rate:  $Q_{\text{cond}} = 2.064 \times 10^5$  watts

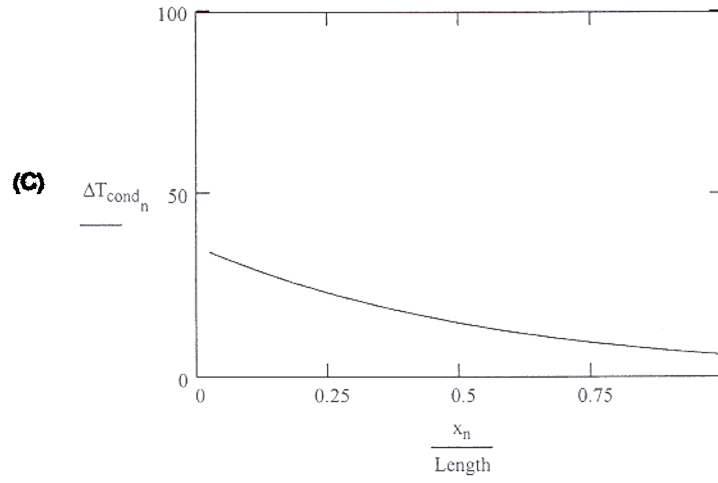
Heat Transfer Rate Per Heat Pipe vs. Normalized Exchanger Length



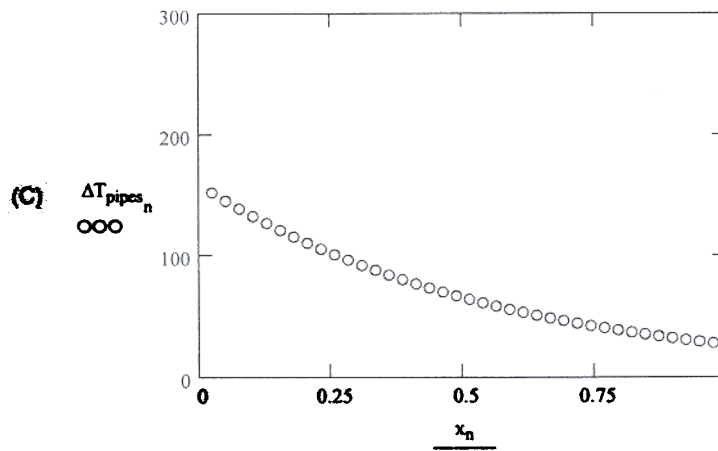
Contribution of the Evaporator-Side to the Overall  $\Delta T$  vs. Normalized Exchanger Length



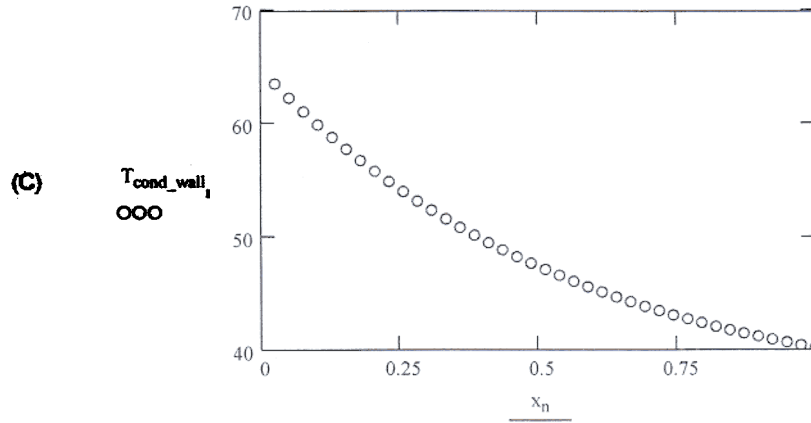
**Contribution of the Condenser-Side to the Overall  $\Delta T$  vs. Normalized Exchanger Length**



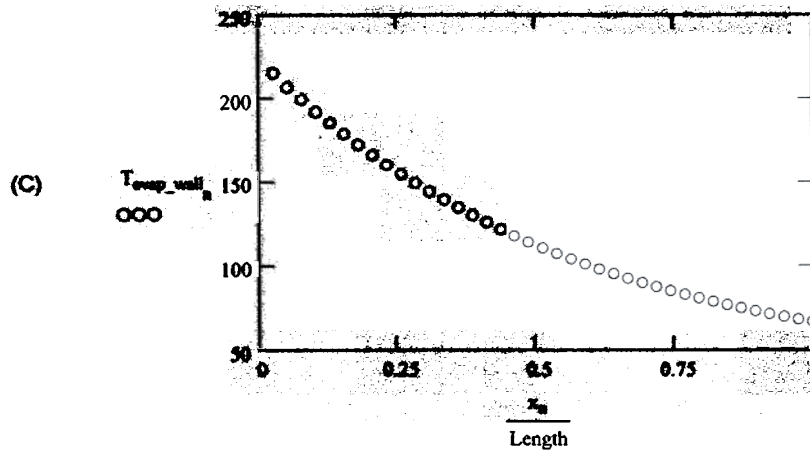
**Contribution of the Heat Pipe to the Overall  $\Delta T$  vs. Normalized Exchanger Length**



Heat Pipe Condenser Wall Temperature vs. Normalized Exchanger Length



Heat Pipe Evaporator Wall Temperature vs. Normalized Exchanger Length



## CONDENSER- AND EVAPORATOR-SIDE PRESSURE DROPS

$$\text{Condenser-side module } \Delta P\text{'s: } \Delta P_{\text{cond}_m} \cdot 1.4504 \cdot 10^{-4} = \begin{pmatrix} 0.421 \\ 0.421 \\ 0.421 \end{pmatrix} \text{ psi}$$

$$\text{Total Condenser-side } \Delta P: \left( \Delta P_{\text{cond\_inlet}} + \sum_m \Delta P_{\text{cond}_m} + \Delta P_{\text{cond\_outlet}} \right) \cdot 1.4504 \cdot 10^{-4} = 1.761 \text{ psi}$$

$$\text{Evaporator-side module } \Delta P\text{'s: } \Delta P_{\text{evap}_m} \cdot 1.4504 \cdot 10^{-4} = \begin{pmatrix} 0.963 \\ 0.963 \\ 0.963 \end{pmatrix} \text{ psi}$$

$$\text{Total Evaporator-side } \Delta P: \left( \Delta P_{\text{evap\_inlet}} + \sum_m \Delta P_{\text{evap}_m} + \Delta P_{\text{evap\_outlet}} \right) \cdot 1.4504 \cdot 10^{-4} = 3.245 \text{ psi}$$

## THERMAL PERFORMANCE METRICS

$$\text{Total Heat Transfer Surface Area: } A_{\text{total}} 10.764 = 330.578 \text{ (ft}^2\text{)}$$

$$\text{Log Mean Temperature Difference: } \text{LMTD} \frac{9}{5} = 214.471 \text{ (}^\circ\text{F)}$$

$$\text{Overall Heat Transfer Coefficient: } U_{\text{overall}} 0.17612 = 9.932 \text{ (BTU/hr/ft}^2\text{/F)}$$

$$R_1 := \frac{\ln\left(\frac{0.84\text{in}}{0.84\text{in} - 2 \cdot 0.125\text{in}}\right)}{2 \cdot \pi \cdot 0.30 \frac{\text{watt}}{\text{cm} \cdot \text{K}} \cdot (\text{Height}_{\text{cond}} \cdot 100\text{cm} + \text{Height}_{\text{evap}} \cdot 100\text{cm})} \quad R_1 = 8.145 \times 10^{-3} \frac{\text{K}}{\text{watt}}$$

$$R_2 := \frac{\ln\left(\frac{0.84\text{in}}{0.84\text{in} - 2 \cdot 0.072\text{in}}\right)}{2 \cdot \pi \cdot 0.30 \frac{\text{watt}}{\text{cm} \cdot \text{K}} \cdot (\text{Height}_{\text{cond}} \cdot 100\text{cm} + \text{Height}_{\text{evap}} \cdot 100\text{cm})} \quad R_2 = 4.336 \times 10^{-3} \frac{\text{K}}{\text{watt}}$$



## POST ANALYSIS REPORT

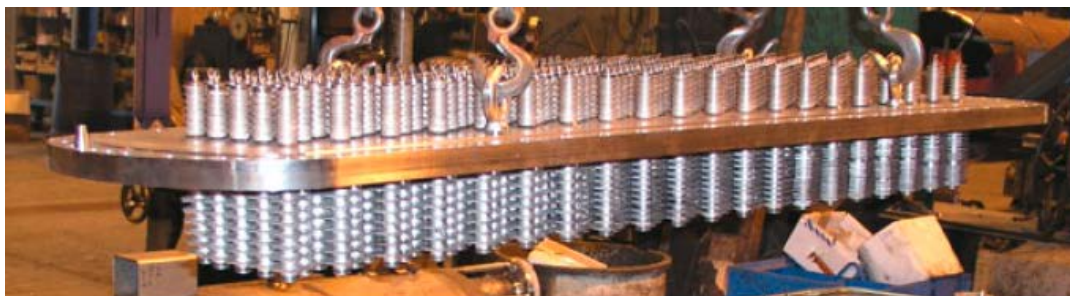
### Heat Pipe Bleed Air Cooler Heat Exchanger

Contract N65540-06-C-0022

March 30, 2007

A.I.Phillips, Thermacore

Denis Colahan, NSWC-CD Phila



## 1. BACKGROUND

### 1.1 Overall Program Objective

Bleed air is extracted from the main propulsion and ship service turbines for use in a variety of functions including ASW Prairie/Masker systems and turbine start functions. Extracted from the 14<sup>th</sup> to 16<sup>th</sup> turbine stages, bleed air can range as hot as 925°F and must be cooled to as low as 190°F when operating at 925°F. Bleed Air Coolers provide this temperature reduction using seawater as the heat sink.

A conventional Bleed Air Cooler (BAC) uses a shell and tube heat exchanger (HX), in which hot bleed air is fed to the shell side and seawater is fed to the tube side. The high temperature air readily heats the seawater side of much of the tube surfaces to temperatures well in excess of the 150°F temperature at which fouling occurs. This fouling precipitates dissolved solids in the seawater, which forms scaling, i.e. calcareous deposits, on the tube walls. Scaling reduces heat transfer capacity which can affect air temperature and downstream applications. Scaling will result in local temperatures which approach the inlet air temperatures; elevated temperatures accelerate corrosion and wear, which then leads to leakage and catastrophic failures. A NAVSEA study concluded that the cost of maintenance and repair of BACs and related components was approximately \$5.7 million per year based on 3M data from 1996 for gas-turbine powered ships and Hazmat usage and disposal

The use of heat pipes eliminates the direct contact of hot air and seawater across a thin tube wall. Instead, heat is transported from the air side to the seawater side of the HX through a number of heat pipes. Heat pipes use the evaporation and condensation of a working fluid to transport heat. One feature of saturated, two phase heat transport is that the entire inside surface of the heat pipe is very nearly the same temperature. Despite more than 600°F difference in temperature between the hot air and the seawater sides, the temperature difference inside the heat pipe is less than 2°. The heat pipe operating temperature is determined by the relative heat transfer from the air and from the water. Since water is much better than air at transferring heat, the heat pipe temperature will be much closer to the water temperature than the air temperature. By directly manipulating the relative heat transfer surfaces (i.e. the relative number and size of the fins and the air and water sides of the heat pipe), the surface temperature on the water side can be maintained below the critical 150°F fouling temperature.

### 1.2 Program History

In previous work beginning in 1999, Thermacore completed design and analysis as well as tasks to build and test a number of heat pipes. Many of these remain active life test. This program established the feasibility of the project and was conducted under contract N65540-00-M-0618. The detailed design and the fabrication of a prototype full-scale heat pipe bleed air cooler (FS-HPBAC) was conducted under contract N65540-03-C-0065. The FS-HPBAC was delivered to NSWC in January, 2005. Sea trials were performed aboard the USS Ramage (DDG 61) during June and July, 2005. The HPBAC significantly underperformed both its calculated performance and that of the conventional shell-and-tube BAC. Analysis work was subsequently performed to determine the cause of the discrepancy.

## 2. ANALYSIS OF PROTOTYPE TEST RESULTS

### 2.1 On-board Test Data Summary

Table 1 presents a snap shot from the large quantity of test data from the side by side comparison of the shell-and-tube bleed air cooler with the heat pipe bleed air cooler. The “MER-1” data (lightly shaded in yellow) is from the heat pipe BAC and the “MER-2” data is from the shell-and-tube BAC.

Table 1 Bleed Air Cooler Sea Trial Test Results											
Date and Time	M30277 MER-1 TC-2 AIR-IN (°F)	M30277 MER-1 TC-4 AIR-OUT (°F)	$\Delta T$ MER-1 air	M30322 MER-2 TC-2 AIR-IN (°F)	M30322 MER-2 TC-4 AIR-OUT (°F)	$\Delta T$ MER-2 air	M30277 MER-1 TC-1 SW-IN (°F)	M30277 MER-1 TC-3 SW-OUT (°F)	M30322 MER-2 TC-1 SW-IN (°F)	M30322 MER-2 TC-3 SW-OUT (°F)	M30742 MER-1 Air Flow (SCFM)
6/24/2005 6:00 AM	554.59	389.35	<b>165.24</b>	568.85	138.20	<b>430.6</b>	70.47	75.02	70.21	77.83	1707
6/29/2005 3:30 AM	541.58	362.25	<b>179.33</b>	560.66	139.86	<b>420.8</b>	70.95	74.16	70.72	80.67	1287
6/29/2005 12:45 AM	544.66	364.87	<b>179.78</b>	564.37	140.67	<b>423.7</b>	70.70	73.99	70.48	80.67	1309
Results After Installation of Baffle Plates											
7/27/2005 2:00 PM	543.79	322.99	<b>220.81</b>	511.34	141.76	<b>369.6</b>	84.34	89.92	83.91	85.93	1749

The amount of heat removed from the bleed air is proportional to the difference in temperature between the inlet and outlet, the higher this value, the better the heat transfer. This value is shown in boldface in the  $\Delta T$  column. In the trials on 6/24 and 6/29 the heat pipe BAC was performing at roughly 42% of what the shell-in-tube BAC was performing at.

Part of this performance was due to the bleed air flowing around the fins and heat pipes due to excessive clearances. After baffle plates were installed to somewhat alleviate this bypass flow, the HPBAC performance improved to almost 60% of the shell-in-tube.

It should be noted that the whole purpose of the HPBAC is to keep the water side temperature below the critical fouling temperature of 150°F. To reduce the seawater side temperature and prevent calcareous deposits, the HPBAC deliberately incorporates additional built-in thermal resistance so its  $\Delta T$  is designed to be about 80% that of the shell-in-tube BAC. Table 2 compares the calculated results for the test conditions with those actually measured. Again the critical  $\Delta T$  values are shown in boldface. In the initial tests the HPBAC was performing at 58% of its expected performance, and this improved to 83% after the installation of the flow baffles.

Table 3 shows the measured thermal resistance from the instrumented heat pipes. Eight of the 195 heat pipes were instrumented during the tests. Table 4 indicates which pipes were instrumented in the 3 modules of the cooler. These temperature measurements were used to determine the thermal resistance of these heat pipes which ranged from two to five times the target value of 0.06°C/watt. The average resistance for the eight instrumented heat pipes was 0.205°C/watt. Again, the key parameter to compare is the airside temperature difference. In review of table 4 it should be noted that only 2 instrumented pipes were operational, 3 were

APPENDIX B

partially operational, 2 were significantly degraded, and 1 was non operational. The predicted temperature difference for the 6/24/05 data is significantly higher (114F) then the measured results. This also is true for the other data sets.

<b>Table 2 Comparison of Measured versus Predicted Performance for HPBAC.</b>								
	<b>Date and Time</b>	<b>M30277 MER-1 TC-2 AIR-IN (°F)</b>	<b>M30277 MER-1 TC-4 AIR-OUT (°F)</b>	<b>Δ T MER-1 air</b>	<b>M30277 MER-1 TC-1 SW-IN (°F)</b>	<b>M30277 MER-1 TC-3 SW-OUT (°F)</b>	<b>Δ T MER-1 SW</b>	<b>M30742 MER-1 Air Flow (SCFM)</b>
Measured	6/24/2005	554.59	389.35	<b>165.24</b>	70.47	75.02	4.55	1707
Predicted		554.59	275.2	<b>279.39</b>	70.47	77.7	7.00	1707
Measured	6/29/2005	541.58	362.25	<b>179.33</b>	70.95	74.16	3.20	1287
Predicted		541.5	236.39	<b>305.11</b>	70.95	76.41	5.71	1287
Measured	6/29/2005	544.66	364.87	<b>179.78</b>	70.70	73.99	3.29	1309
Predicted		544.66	239.27	<b>305.39</b>	70.70	76.29	5.59	1309
<b>Baffle Plates Installed</b>								
Measured	7/27/2005	543.79	322.99	<b>220.81</b>	84.34	89.92	5.58	1749
Predicted		543.79	279.72	<b>264.07</b>	84.34	90.80	6.46	1749

<b>Table 3. Measured Heat Pipe Thermal Resistance, C/W</b>									
Trial Date	Row 1 #2	Row 1 #4	Row13 #2	Row13 #4	Row26 #2	Row26 #4	Row39 #2	Row39 #4	Avg.
6/24/05	0.253	0.223	0.234	0.215	0.17	0.156	0.124	0.135	0.189
6/29/05	0.309	0.259	0.267	0.242	0.182	0.171	0.131	0.144	0.213
6/29/05	0.306	0.254	0.264	0.240	0.181	0.17	0.132	0.144	0.212
<i>No temperature data was available from the 7/27/05 test.</i>								<b>Overall Average</b>	<b>0.205</b>

### 3. POST-TEST EVALUATION OF HEAT PIPE BLEED AIR COOLER

#### 3.1 Post-Operation Diagnostic Tests at Thermacore

Initial review and analysis of the on-board test data was used to compile a list of causes that could have contributed to the reduced thermal performance of the HPBAC. The lack of HP BAC measured performance was linked to the following issues. With heat pipe operation/thermal resistance being the significant technical issue as a result of the.

- **Fin Attachment:** Issues were raised concerning fin attachment to the heat pipes. In many instances, the heat pipe-to-fin braze was not complete and weak. More development work in this area needs to be done in order to improve the fin attachment method.
- **Fins per Inch:** Due to fabrication issues, there were several less fins than desired. It is possible that increasing the fins per inch on the airside is desired. Unfortunately, there is no airside pressure drop values measured during the shipboard testing to provide design guidance in this area.
- **Heat Pipe Operation:** There are issues with the heat pipes. The target thermal resistance for the heat pipes established at the start of the program was  $0.06^{\circ}\text{C}/\text{W}$ . NSWC instrumented eight heat pipes during the shipboard testing. This data was used to determine the actual heat pipe thermal resistance. This values listed in Table 3 indicate that the average heat pipe thermal resistance is about  $0.205\text{ C}/\text{W}$ , 3.41 times higher then desired. This significantly adds to reduced HP BAC performance.
- **Flow Bypass:** There are large gaps around the perimeter of the heat pipe fin stack. Recently, NSWC installed three baffle plates and showed approximately 40F improvement (see Table 1) in the airside temperature difference. The best solution, however, is to seal against the entire heat pipe bundle.

In November 2006, the HPBAC unit was returned to Thermacore for detailed evaluation. Using the above list as a guideline, the unit was disassembled and the components were evaluated individually to identify the causes of the reduced performance.

The top and bottom half-shells of the unit were removed to reveal the heat pipe divider plate subassembly. Initial inspection showed some impingement damage to the condenser (seawater) end of the heat pipes near the seawater inlet. This appears to have been caused by the internal configuration of putting a square box in a round circle, i.e. during retro-fitting of the unit with flow baffles. To avoid this situation, it is recommended to modify the baffles to direct the water flow axially through the fins, and not directed downward onto the upper fin surfaces. This will most likely resolve itself once the diverter baffles are eliminated by using a circular tube sheet configuration in the circular shell, which is the plan for the production style cooler.



**Figure 1 shows impingement damage to the heat pipes near the water inlet.**

It was decided to perform a thermal performance test on each individual heat pipe in the array of 195 heat pipes. The test was designed to identify potential causes of the reduced thermal performance observed during on-board operation. Potential problems could include a loss of fluid charge or accumulation of non-condensing gas. All tests were started with an initial uniform ambient temperature. Each heat pipe was individually tested using a 150 watt heat source applied to its bottom (evaporator) surface. The heat pipes were instrumented with two thermocouples. One was attached to the outer envelope surface near the bottom end, and a second was attached to the envelope near the upper end cap. Heat was applied for up to ten minutes, or until the top of the heat pipe reached a temperature of 50C. The temperature of each end of the device was then recorded, along with any unique observations regarding the warm-up dynamics. Figure 2 shows the base of a heat pipe with the resistance heat source and lower thermocouple location. Figure 3 shows the top end of the same heat pipe and the upper thermocouple location.

After each of the heat pipes was tested, the data were reviewed to identify patterns suggestive of degraded thermal performance. The temperature difference across each heat pipe was plotted as a function of position in the heat exchanger. Table 4 shows the measured temperature drop for each heat pipe in the tube bundle. The measured temperature drop ranged from 13.7C to 144.5C. The data were reviewed, and the heat pipes were divided into four categories.

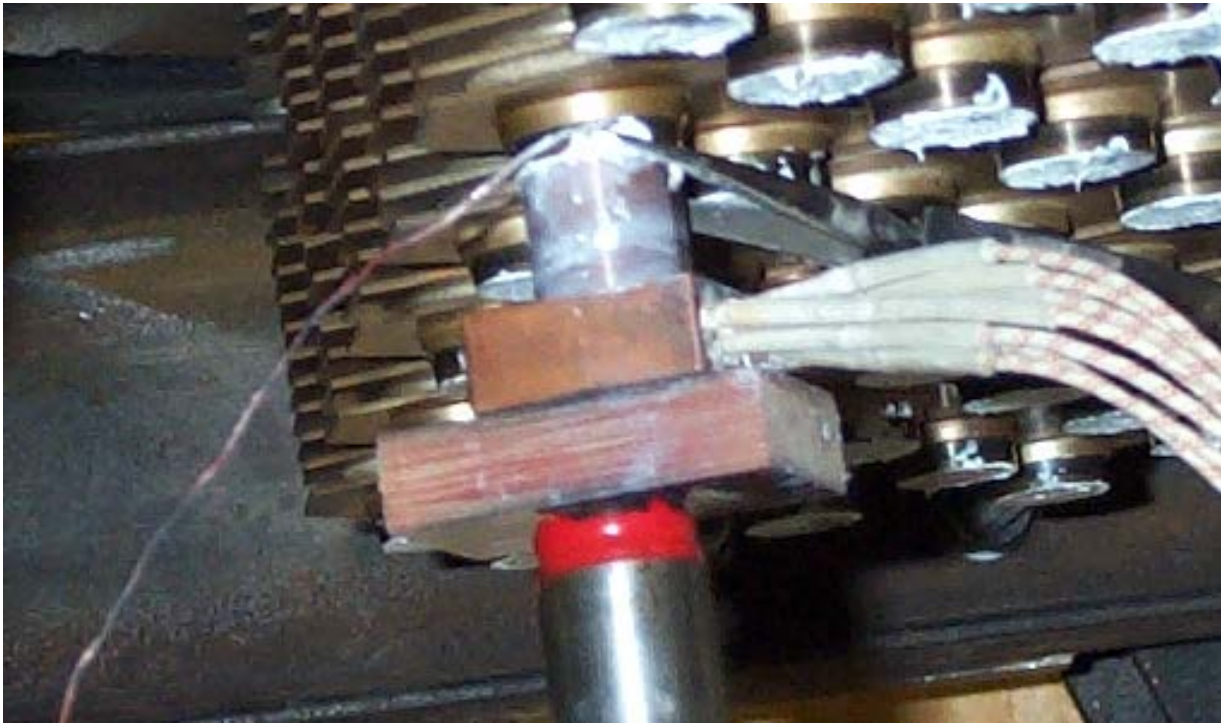


Figure 2 – Lower end of a heat pipe during the performance verification test.



Figure 3 – Upper end of a heat pipe during a performance verification test.

APPENDIX B

Table 4 – Measured Temperature Drops for the Heat Pipes in the Tube Bundle

Pipe Row		Pipe No.				
		1	2	3	4	5
M O D U L E -- 1  inlet	1	31.5	110.0	54.4	28.4	13.7
	2	102.4	37.6	50.2	56.5	41.5
	3	106.3	99.6	122.8	67.4	43.9
	4	34.0	77.3	108.1	106.6	98.1
	5	102.6	107.4	109.4	103.9	117.0
	6	111.2	95.8	106.6	99.6	94.0
	7	98.1	96.6	95.4	89.9	90.8
	8	101.5	24.7	89.9	62.9	111.0
	9	40.8	36.3	93.8	111.9	110.8
	10	39.2	82.0	27.6	101.6	103.9
	11	88.7	59.5	95.3	88.2	76.7
	12	103.1	106.6	112.0	102.7	106.7
	13	64.4	80.5	124.3	68.0	51.6
M O D U L E -- 2	14	103.4	89.1	41.1	84.9	82.0
	15	51.2	53.4	43.7	135.2	47.1
	16	38.1	47.6	48.3	144.5	45.3
	17	97.5	52.0	50.4	44.5	31.5
	18	45.2	28.8	48.7	46.9	40.4
	19	41.1	33.9	46.9	32.3	46.3
	20	39.9	73.5	39.7	45.1	51.4
	21	56.6	42.4	120.5	60.6	121.5
	22	45.0	58.8	52.1	76.1	53.3
	23	50.2	40.8	45.4	38.0	51.3
	24	24.1	17.9	33.6	24.4	27.5
	25	47.0	27.7	35.5	39.7	34.2
26	50.5	30.0	30.1	44.3	44.1	
M O D U L E -- 3  outlet	27	58.2	43.9	64.9	48.1	65.8
	28	35.0	48.1	58.6	52.6	130.1
	29	65.6	47.9	55.9	46.9	121.4
	30	63.0	60.3	49.5	53.3	50.2
	31	128.1	53.8	63.9	54.3	58.8
	32	61.8	41.4	103.2	55.6	51.5
	33	99.0	79.8	83.5	46.5	42.0
	34	49.2	103.6	98.4	71.6	58.7
	35	65.5	61.0	50.1	59.6	55.2
	36	53.7	55.7	57.8	59.8	49.3
	37	54.4	120.2	63.1	49.3	55.5
	38	57.9	54.5	50.1	66.0	47.4
	39	50.4	39.8	49.0	47.2	43.0
		Module 1 (1,2 & 2,4)		Module 1 (13,2&13,4)	Module 2 (26,2&26,4)	Module 3 (39,2&39,4)
Thermocouples attached to						



Operational HP below 35 C (95F)	19 Heat Pipes	10 %
Partially Operational HP 35 C to 65 C (95F to 149F)	105 Heat Pipes	54%
Significantly Degraded HP 65 C to 100 C (149 F to 212 F)	35 Heat Pipes	18 %
Non-Operational HP Above 100 C (212 F)	36 Heat Pipes	18 %



1) Operational Heat Pipes

Nineteen heat pipes exhibited a temperature drop of less than 35C; this is 10% of the total. These devices would be capable of operating nearly as designed in a HPBAC at normal operating conditions. A small amount of non-condensing gas may be present, but it should not significantly affect thermal performance.

2) Partially Operational Heat Pipes

One hundred five heat pipes exhibited a temperature drop between 35C and 65C; this is 54% of the total. These heat pipes would be capable of partially transferring heat by evaporation and condensation at normal operating conditions. However, there appears to be a measurable amount of non-condensing gas present in these devices – enough to degrade the thermal performance by about 50%.

3) Significantly Degraded Heat Pipes

Thirty five heat pipes exhibited a temperature drop between 65C and 100C; this is 18% of the total. These heat pipes would be capable of transferring only a small amount of heat during normal operation in a BAC, e.g. 25%. The cause appears to be a large amount of non-condensing gas in the devices.

4) Non-Operational Heat Pipes

Thirty six heat pipes exhibited a temperature drop greater than 100C; this is 18% of the total. These devices are essentially non-operational, and would not be capable of transferring useful heat during normal operation of a BAC.

In summary nearly 36% of the heat pipes are either non-operational or are significantly degraded from non-condensing gas generation. An additional 54% exhibited measurably reduced thermal

performance. Collectively, this would result in an expected 40% decrease in the effective heat transfer of the heat pipe tube bundle.

A detailed review of the heat pipe fabrication procedure was conducted to determine the cause of the problem. The fabrication procedure used by subcontractor Advanced Cooling Technologies (ACT) was scrutinized to identify procedural causes. Several items were identified that are believed to have collectively created the degraded condition of the heat pipes. First, the heat pipes were not operated at elevated temperatures before the sealing step. The procedure that was used included use of a roughing vacuum pump to degas the heat pipe; pinch/seal of the fill tube was done without operating each heat pipe beforehand. Thermacore experience has shown that copper/nickel alloys produce a compatible envelope for water heat pipes only after a short period of operation at temperature exceeding the anticipated normal operating environment. This was not done for the BAC heat pipes. Secondly, the heat pipes were not operated after pinch/seal to confirm that the pinch/seal was vacuum-tight. Collectively, these procedure processes would have created several potential conditions to degrade heat pipe performance, including entrapment of air, entrapment of hydrogen gas, and loss of water fluid charge during normal operation.

#### **4. CONCLUSIONS AND RECOMMENDATIONS**

Tests were conducted at Thermacore under Contract N65540-06-C-0022 (CDRL Item A002) to identify causes of the reduced thermal performance of a heat pipe cooled bleed air cooler developed under a previous contract. Specific conclusions and recommendations include the following items:

1. The heat exchanger was disassembled and inspected. Visual inspection revealed some mechanical damage and erosion of water-side fins near the water inlet. The cause of this appears to be the re-directed water inlet flow from the retrofitted flow baffles. This will most likely resolve itself once the diverter plates are eliminated in using a circular tube sheet configuration in the circular shell, which is the plan for the production style cooler
2. Each heat pipe was thermally tested to identify performance anomalies internal to the heat pipes. It appears that the majority of the heat pipes were found to contain a significant amount of non-condensing gas; the collective effect would be to reduce the available internal heat transfer surface area by nearly 40%.
3. Specific recommendations to modify the heat exchanger fabrication procedure include operation of each heat pipe at 200C for 30 minutes prior to pinch/seal and a step to operate each heat pipe post pinch/seal to confirm that successful processing and pinch/seal was realized.
4. The internal baffles in the heat exchanger shell should be re-designed to provide a tight seal around the heat pipe bundle on both air side and waterside of the heat exchanger. This effort should include a modification of the baffle inlet region to avoid re-directing water downward onto fin surfaces.

## APPENDIX B

5. The fin design and attachment procedure should be modified to provide complete braze fillets between the fins and the heat pipes. Work on this aspect of the design is already in progress.
6. The height of the heat pipes could be increased to fill the internal volume inside the heat exchanger shell. This option should be included in the re-design effort.
7. Of all the technical factors which may have contributed to the degraded thermal performance the heat pipe operation/thermal resistance would have to be the most significant. The plus is that these are all very fixable with better heat pipe fabrication processes.

## Bleed Air Cooler Thermosyphon Address Convention

### Purpose

Specify an address convention for identifying thermosyphons in the tube bundle array.

### Proposed Convention:

The address convention consists of an ordered pair of indices, where the first index indicates a thermosyphon row and the second index indicates a thermosyphon within the row:

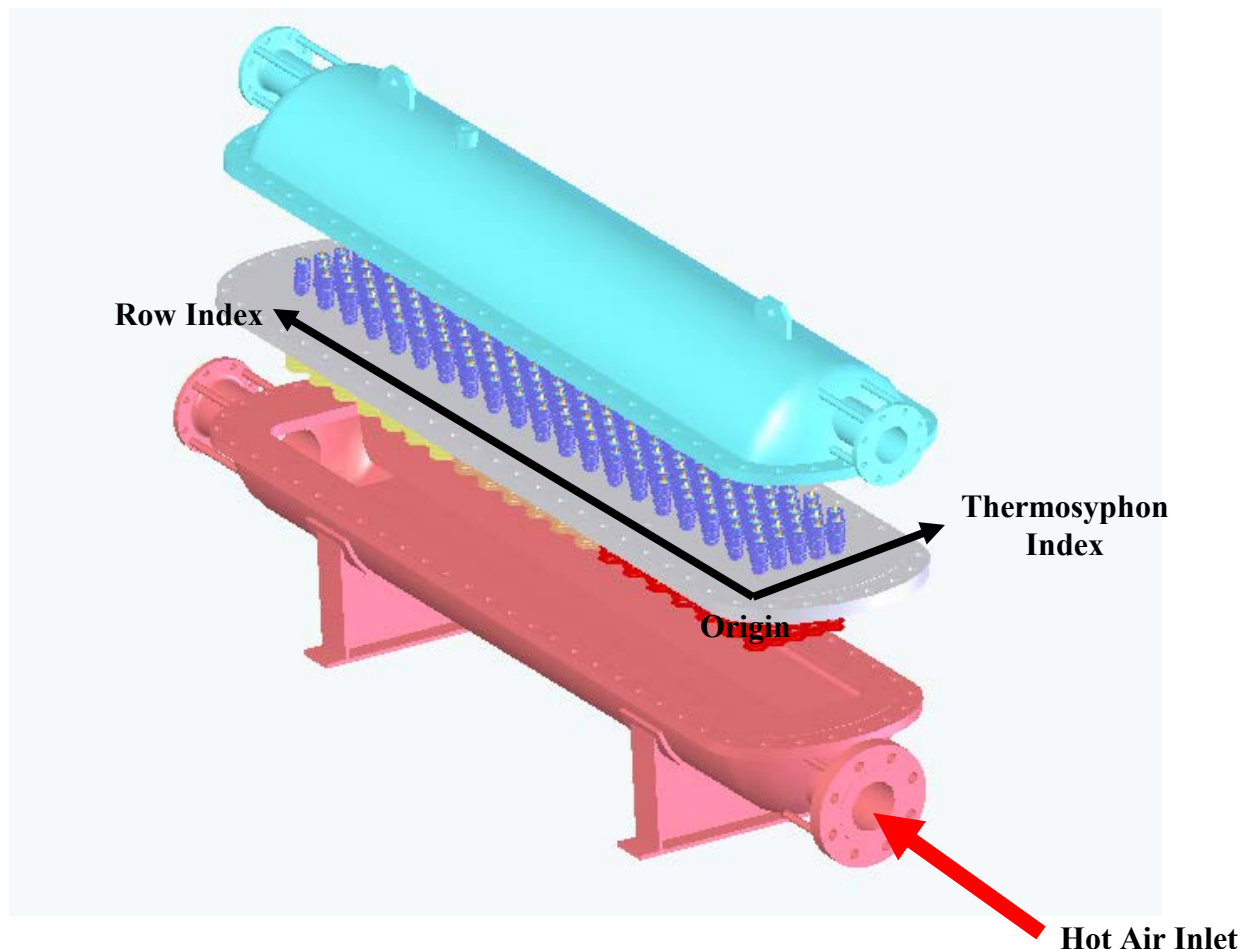
$$(RowIndex, ThermosyphonIndex)$$

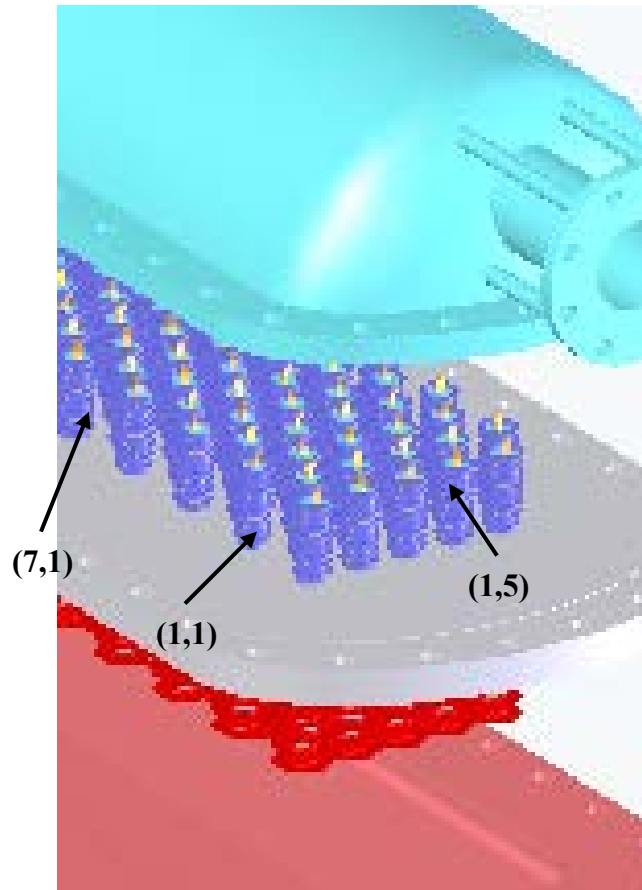
where

$$1 \leq RowIndex \leq 39$$

$$1 \leq ThermosyphonIndex \leq 5$$

The index origin is identified in the figure below.



Examples

- Thermosyphons having a 2fpi air-side density (“Module 1”) span the address range from (1,1) to (13,5).
- Thermosyphons having a 3fpi air-side density (“Module 2”) span the address range from (14,1) to (26,5).
- Thermosyphons having a 5fpi air-side density (“Module 3”) span the address range from (27,1) to (39,5).

## **Appendix C**

### **FINAL REPORT - Redesign of Full Scale Heat Pipe Bleed Air Cooler Heat Exchanger**

## Final Report

# Redesign of Full Scale Heat Pipe Bleed Air Cooler Heat Exchanger

**Data Item A007**  
**Contract No. N65540-06-0022**



**HP-BAC at Wyle Laboratories Ready for Testing April 8, 2008**

Prepared for  
**Naval Surface Warfare Center, Carderock Division**  
**5001 South Broad Street**  
**Philadelphia, PA 19112-1403**

**August 29, 2008**



Thermacore Inc.

## Table of Contents

Program Summary.....	1
1 Background.....	3
2. The HP-BAC Redesign Program.....	4
3. Task 1 Post-Test Analysis of HP-BAC.....	4
3.1 Summary of On-board Test Data.....	4
3.2 Post-Operation Diagnostic Tests at Thermacore .....	6
3.2.1 Review and Analysis of On Board Test Results.....	6
3.2.2 Post-Operation Inspection and Tests at Thermacore .....	6
4. Redesign of HP-BAC.....	10
4.1 Reduction of Heat Pipe Thermal Resistance .....	10
4.1.1 Analysis of Fabrication Procedures on Heat Pipe Thermal Resistance.....	10
4.1.2 Heat Pipe Redesign and Test .....	10
4.2 Improved Fins and Fin Attachment .....	11
4.2.1 The Fin Attachment Problem.....	11
4.2.2 New Fin Design and Fabrication .....	12
4.2.3 Braze Comparisons .....	13
4.2.4 Fin to Heat Pipe Conductivity Test.....	14
4.2.5 Fin and Braze Conclusions .....	15
5. Fabrication and Testing of Heat Pipes.....	15
5.1 Heat Pipe Testing Index.....	15
5.1.1 Initial Thermal Resistance Pipes June 2007 .....	16
5.1.2 Plated Felt Pipes - HPs #1 - #7 .....	16
5.1.3 Transitional Heat Pipes HPs #“A” thru #“F” .....	16
5.1.4 Test Plate Pipes .....	17
5.2 Decisive Heat Pipe Tests .....	18
5.2.1. Heat Pipes #1 and #2.....	19
5.2.2. Heat Pipe #3 - Gassing.....	20
5.2.3 Heat Pipe #4 – Weld Cracking.....	20
5.2.4 Transitional Heat Pipes to Diagnose & Resolve Gassing.....	21
5.2.5 The HP-BAC Test Article Heat Pipes .....	22
5.3 Hydrostatic Tests .....	23
6. Design and Fabrication of HP-BAC Engineering Test Unit.....	24
6. Design and Fabrication of HP-BAC Engineering Test Unit.....	25
6.1 Ducts and Baffles.....	25
6.2 Heat Pipe Processing.....	27
6.3.1 Background - Conventional Copper/Water Heat Pipes .....	27



APPENDIX C

6.3.2 Heat Pipes for The First Prototype..... 27

6.3.3 Upgraded Heat Pipe Design and Processing..... 28

7 Testing..... 30

7.1 Test Hardware and Facility..... 30

7.1.1 The Engineering Test Unit..... 30

7.1.2 Thermocouples..... 30

7.1.3 Test Facility and Equipment..... 32

7.2. Test Objectives and Test Plan..... 32

7.2.1 Objectives ..... 32

7.2.2 Test Plan..... 34

7.3. Test Results..... 34

7.3.1 Test Campaign Overview ..... 34

7.3.2 Models Used for Test Data Analysis ..... 35

7.3.3 Results from Testing of June 12, 2008 ..... 36

7.3.4 Heat Pipe “D” Testing, Nov.-Dec. 2007..... 37

7.4. Analysis and Conclusions..... 39

7.4.1 Discussion of Results from Lab Test Baseline ..... 40

7.4.2 Discussion of Results from Wyle Test Conditions..... 41

7.5. Interpretation of Results..... 42

7.5.1 Overall Conclusions/Interpretations ..... 42

7.5.2 Project Engineer’s Conclusions/Interpretations/Conjecture ..... 43

7.6 Actions Going Forward..... 43

## Program Summary

### Program Motivation

The Heat Pipe Bleed Air Cooler (HPBAC) can maintain the seawater side of the heat exchanger below the 150°F salt scaling temperature, thus greatly reducing fouling and the \$2.3 million per year maintenance costs and \$3 million in system support costs associated with the present shell and tube designs.

### Previous work

Previous work culminated in sea trials of a full scale prototype aboard the USS Ramage in June, 2005. The performance of the HPBAC as a heat exchanger fell considerably short of predictions, reducing bleed air temperature by only 179°F, some 125°F less than the expected reduction of 305°F. The bypass flow was known to be significantly worse than design conditions, so baffles were added and the unit reinstalled and tested again in July, 2005. The baffles improved heat transfer considerably; the unit reduced bleed air temperature by 220°F but this was still some 40°F less than the expected reduction of 260°F. The testing was terminated without obtaining any data on fouling performance. In addition to the bypass of much of the airflow around (rather than through) the heat pipe fins, a number of other parameters fell short of the conditions used for the design calculations.

### Program Objectives

The program was instituted to analyze the previous work and determine causes, come up with plans and designs to correct those problems, build a test unit, and confirm that the designs corrected the problems and that the HP-BAC was worth going forward.

### Test and Diagnosis

The old HP-BAC was extensively tested. Only 10% of the heat pipes were operating at fully rated performance. The problems with fins and bypass flow were confirmed. This work is reported in Section 3.

### Redesign of HP-BAC

The heat pipe processing was changed so the copper-nickel heat pipes were processed the same as liquid metal heat pipes rather than the simpler procedures followed for commercial copper water heat pipes. Instead of simple thermosyphons, a number of improvements were tried and sintered copper wicks were added to the design. The heat pipe improvements are reported in Section 4.1.

The formed fins could not be efficiently brazed to the tube walls, resulting in large thermal resistance. Cast fins were used from Vforge with support from Advanced Technology Institute and US Army Research Lab. Delta-T was reduced from 62°C to less than 10°C with the new fins and brazing. The fin improvements are reported in Section 4.2.

### Fabricate and Test Heat Pipes

More than forty heat pipes of various configuration were fabricated and tested. Potential problems with gassing and weld cracking were identified, solved, and design changes were implemented to preclude them in the future. This work is reported in Section 5.

### Design and Fabricate HP-BAC Engineering Test Unit.

A system of ducts and baffles were designed built and installed to resolve the bypass flow issues. Heat pipe processing was upgraded to preclude the degradation observed on the shipboard test

unit. A full scale, but not fully loaded, Engineering Test Unit BAC was fabricated and delivered for full scale testing at Wyle Labs. This work is reported in Section 6.

#### Testing

Testing was conducted at rated temperatures and flow in the Wyle facility in El Segundo CA from April 15 through June 12, 2008. The Engineering Test Unit HP-BAC carried more power at a lower delta-T than predicted by the design models or required by the performed. This work is reported in Section 7.

#### Result

Based on the official test data from Wyle Laboratories, the Heat Pipe Bleed Air Cooler (HP-BAC) transported 15% more power than predicted by the design model. The testing conclusively confirmed that all the corrections/improvements that were made following the unsatisfactory tests aboard the USS Ramage in 2005 resulted in the HP-BAC not only meeting, but far surpassing the original design objectives.

## 1 Background

The Navy has identified a need for an improved Bleed Air Cooler (BAC). The existing BAC is subject to rapid and extensive fouling due to precipitation of solids from the seawater coolant. This leads to \$2.3 million per year maintenance costs and \$3 million in system support costs associated with the present shell and tube designs. The required acid cleaning also raises environmental issues.

Current Bleed Air Coolers (BAC) use a shell and tube heat exchanger (HX) in which hot bleed air is fed to the shell side, and seawater is fed to the tube side. The high temperature air readily heats the seawater side of much of the tube surfaces to temperatures well in excess of the 150°F temperature at which fouling occurs. This fouling precipitates dissolved solids in the seawater which forms scaling, i.e. calcareous deposits, on the tube walls. Scaling reduces heat transfer capacity, which can affect air temperature and downstream applications. Scaling will result in local temperatures which approach the inlet air temperatures; elevated temperatures accelerate corrosion and wear leading to leakage and catastrophic failures. A NAVSEA study concluded that the cost of maintenance and repair of BACs and related components was approximately \$2.3 million per year based on 3M data from 1996 for gas-turbine powered ships.

The use of heat pipes eliminates the direct contact of hot air and seawater across a thin tube wall. Instead, heat is transported from the air side to the seawater side of the HX through a number of heat pipes. Heat pipes use the evaporation and condensation of a working fluid to transport heat. One feature of saturated, two phase heat transport is that the entire inside surface of the heat pipe is very nearly the same temperature. Despite more than 800°F difference in temperature between the hot air and the seawater, the temperature difference inside the heat pipe is less than 2°. The heat pipe operating temperature is determined by the relative heat transfer from the air and from the water. Since water is much better than air at transferring heat, the heat pipe temperature will be much closer to the water temperature than the air temperature. By directly manipulating the relative heat transfer surfaces (i.e. the relative number and size of the fins and the air and water sides of the heat pipe), the surface temperature on the water side can be maintained below the critical 150°F fouling temperature.

An abbreviated design study, which showed the feasibility of the concept, presented several workable designs and identified several technology development and modeling issues requiring further work prior to fabrication of a prototype full-scale heat pipe exchanger (FS-HPBAC).

An advanced study based on further modeling and technology development successfully validated the feasibility of the concept and provided the data needed to confidently proceed with the design and fabrication of a full-scale cooler with a shell enclosure.

Under contract N65540-03-C-0065 a prototype FS-HPBAC was fabricated and delivered to NSWC. This work culminated in sea trials of the full scale prototype aboard the USS Ramage in June, 2005. The performance of the HPBAC as a heat exchanger fell considerably short of predictions, reducing bleed air temperature by only 179°F, which was 125°F less than the expected reduction of 305°F.

The bypass flow was known to be significantly worse than design conditions, so baffles were added to the shell, and the unit reinstalled and tested again in July, 2005. The baffles improved heat transfer considerably; the unit reduced bleed air temperature by 220°F but this was still some 40°F less than the expected reduction of 260°F. The testing was terminated without obtaining any data on fouling performance.

A number of specific issues were identified or hypothesized; the present contract was issued to identify, resolve and rectify these issues.

## 2. The HP-BAC Redesign Program

The base contract consisted of seven tasks/deliverables. These are:

1. Post Analysis of prototype HP-BAC (Data Item A001)
2. Redesign (Data Item A002)
  - a. Thermal Resistance
  - b. Fin attachment
  - c. Engineering Test Unit Design
3. Testing and Analysis (Data Item A003)
4. Deliver Engineering Test Unit (Data Item A004)
5. Deliver Demonstration Heat Pipes (Data Item A005)
6. Production Cost Analysis (Data Item A006)
7. Final Report. (Data Item A007)

The program closely followed these tasks and Data Items. The final report follows this organization as well. For reporting and payment purposes, task 2, Data Item A002, was broken into two Events.

## 3. Task 1 Post-Test Analysis of HP-BAC\

### 3.1 Summary of On-board Test Data

Table 1 presents the test data from the side by side comparison of the shell-and-tube bleed air cooler with the heat pipe bleed air cooler. The “MER-1” data (lightly shaded in yellow) is from the heat pipe BAC and the “MER-2” data is from the shell-and-tube BAC.

<b>Table 1 Bleed Air Cooler Sea Trial Test Results</b>											
<b>Date and Time</b>	<b>M30277 MER-1 TC-2 AIR-IN (°F)</b>	<b>M30277 MER-1 TC-4 AIR-OUT (°F)</b>	<b>Δ T MER-1 air</b>	<b>M30322 MER-2 TC-2 AIR-IN (°F)</b>	<b>M30322 MER-2 TC-4 AIR-OUT (°F)</b>	<b>Δ T MER-2 air</b>	<b>M30277 MER-1 TC-1 SW-IN (°F)</b>	<b>M30277 MER-1 TC-3 SW-OUT (°F)</b>	<b>M30322 MER-2 TC-1 SW-IN (°F)</b>	<b>M30322 MER-2 TC-3 SW-OUT (°F)</b>	<b>M30742 MER-1 Air Flow (SCFM)</b>
6/24/2005 6:00 AM	554.59	389.35	165.24	568.85	138.20	430.6	70.47	75.02	70.21	77.83	1707
6/29/2005 3:30 AM	541.58	362.25	179.33	560.66	139.86	420.8	70.95	74.16	70.72	80.67	1287
6/29/2005 12:45 AM	544.66	364.87	179.78	564.37	140.67	423.7	70.70	73.99	70.48	80.67	1309
<b>Results After Installation of Baffle Plates</b>											
7/27/2005 2:00 PM	543.79	322.99	220.81	511.34	141.76	369.6	84.34	89.92	83.91	85.93	1749

APPENDIX C

The amount of heat removed from the bleed air is proportional to the difference in temperature between the inlet and outlet, the higher this value, the better the heat transfer. This value is shown in boldface in the  $\Delta T$  column. In the trials on 6/24 and 6/29 the heat pipe BAC was performing at roughly 42% as well as the shell-in-tube BAC.

Part of this performance shortfall was due to the bleed air flowing around the fins and heat pipes due to excessive clearances. After baffle plates were installed to somewhat alleviate this bypass flow, the HPBAC performance improved to almost 60% of the shell-in-tube.

It should be noted that the whole purpose of the HPBAC is to keep the water side temperature below the critical fouling temperature of 150°F. To reduce the seawater side temperature and prevent calcareous deposits, the HPBAC deliberately incorporates additional built-in thermal resistance so its  $\Delta T$  is designed to be about 80% that of the shell-in-tube BAC. Table 2 compares the calculated results for the test conditions with those actually measured. Again the critical  $\Delta T$  values are shown in boldface. In the initial tests the HPBAC was performing at 58% of its expected performance, and this improved to 83% after the installation of the flow baffles.

Table 3 shows the measured thermal resistance from the instrumented heat pipes. Eight of the 195 heat pipes were instrumented during the tests. These temperature measurements were used to determine the thermal resistance of these heat pipes which ranged from two to five times the target value of 0.06°C/watt. The average resistance for the eight instrumented heat pipes was 0.205°C/watt. Again, the key parameter to compare is the airside temperature difference. The predicted temperature difference for the 6/24/05 data is significantly higher (114F) then the measured results. This also is true for the other data sets.

<b>Table 2 Comparison of Measured versus Predicted Performance for HPBAC.</b>								
	<b>Date and Time</b>	<b>M30277 MER-1 TC-2 AIR-IN (°F)</b>	<b>M30277 MER-1 TC-4 AIR-OUT (°F)</b>	<b><math>\Delta T</math> MER-1 air</b>	<b>M30277 MER-1 TC-1 SW-IN (°F)</b>	<b>M30277 MER-1 TC-3 SW-OUT (°F)</b>	<b><math>\Delta T</math> MER-1 SW</b>	<b>M30742 MER-1 Air Flow (SCFM)</b>
Measured	6/24/2005	554.59	389.35	<b>165.24</b>	70.47	75.02	4.55	1707
Predicted		554.59	275.2	<b>279.39</b>	70.47	77.7	7.00	1707
Measured	6/29/2005	541.58	362.25	<b>179.33</b>	70.95	74.16	3.20	1287
Predicted		541.5	236.39	<b>305.11</b>	70.95	76.41	5.71	1287
Measured	6/29/2005	544.66	364.87	<b>179.78</b>	70.70	73.99	3.29	1309
Predicted		544.66	239.27	<b>305.39</b>	70.70	76.29	5.59	1309
Baffle Plates Installed								
Measured	7/27/2005	543.79	322.99	<b>220.81</b>	84.34	89.92	5.58	1749
Predicted		543.79	279.72	<b>264.07</b>	84.34	90.80	6.46	1749

Trial Date	Row 1 #2	Row 1 #4	Row13 #2	Row13 #4	Row26 #2	Row26 #4	Row39 #2	Row39 #4	Avg.
6/24/05	0.253	0.223	0.234	0.215	0.17	0.156	0.124	0.135	0.189
6/29/05	0.309	0.259	0.267	0.242	0.182	0.171	0.131	0.144	0.213
6/29/05	0.306	0.254	0.264	0.240	0.181	0.17	0.132	0.144	0.212
<i>No temperature data was available from the 7/27/05 test.</i>								Overall Average	<b>0.205</b>

## 3.2 Post-Operation Diagnostic Tests at Thermacore

### 3.2.1 Review and Analysis of On Board Test Results.

Initial review and analysis of the on-board test data was used to compile a list of causes that could have contributed to the reduced thermal performance of the HPBAC. The lack of HP BAC measured performance was linked to the following issues.

- **Fin Attachment:** Issues were raised concerning fin attachment to the heat pipes. In many instances, the heat pipe-to-fin braze was not complete and weak. More development work in this area needs to be done in order to improve the fin attachment method.
- **Fins per Inch:** Due to fabrication issues, there were several less fins than desired. It is possible that increasing the fins per inch on the airside is desired. Unfortunately, there is no airside pressure drop values measured during the shipboard testing to provide design guidance in this area.
- **Heat Pipe Operation:** There are issues with the heat pipes. The target thermal resistance for the heat pipes established at the start of the program was 0.06°C/W. NSWC instrumented eight heat pipes during the shipboard testing. This data was used to determine the actual heat pipe thermal resistance. This values listed in Table 3 indicate that the average heat pipe thermal resistance is about 0.205 C/W, 3.41 times higher then desired. This significantly adds to reduced HP BAC performance.
- **Flow Bypass:** There are large gaps around the perimeter of the heat pipe fin stack. Recently, NSWC installed three baffle plates and showed approximately 40F improvement (see Table 1) in the airside temperature difference. The best solution, however, is to seal against the entire heat pipe bundle.

### 3.2.2 Post-Operation Inspection and Tests at Thermacore

In November 2006, the HP-BAC unit was returned to Thermacore for detailed evaluation. Using the above list as a guideline, the unit was disassembled and the components were evaluated individually to identify the causes of the reduced performance.

The top and bottom half-shells of the unit were removed to reveal the heat pipe divider plate subassembly. Initial inspection showed some impingement damage to condenser (seawater) end of the heat pipes near the seawater inlet. This appears to have been caused by the retrofitting of the unit with flow baffles. To avoid this situation, it is recommended to modify the baffles to direct the water flow axially through the fins, and not directed downward onto the upper fin surfaces.



**Figure 1 Impingement Damage to the Heat Pipes near the Water Inlet.**

A thermal performance test was performed on each individual heat pipe in the array of 195 heat pipes. The test was designed to identify potential causes of the reduced thermal performance observed during on-board operation. Potential problems could include a loss of fluid charge or accumulation of non-condensing gas. All tests were started with an initial uniform ambient temperature. Each heat pipe was individually tested using a 150 watt heat source applied to its bottom (evaporator) surface. The heat pipes were instrumented with two thermocouples. One was attached to the outer envelope surface near the bottom end, and a second was attached to the envelope near the upper end cap. Heat was applied for up to ten minutes, or until the top of the heat pipe reached a temperature of 50C. The temperature of each end of the device was then recorded, along with any unique observations regarding the warm-up dynamics.

After each of the heat pipes was tested, the data were reviewed to identify patterns suggestive of degraded thermal performance. Table 4 shows the measured temperature drop for each heat pipe in the tube bundle. The measured temperature drop ranged from 13.7C to 144.5C.



APPENDIX C

Table 4 Measured Temperature Drop for each Heat Pipe						
Pipe Row		Pipe Number.				
		1	2	3	4	5
M O D U L E -- 1  inlet	1	31.5	110.0	54.4	28.4	13.7
	2	102.4	37.6	50.2	56.5	41.5
	3	106.3	99.6	122.8	67.4	43.9
	4	34.0	77.3	108.1	106.6	98.1
	5	102.6	107.4	109.4	103.9	117.0
	6	111.2	95.8	106.6	99.6	94.0
	7	98.1	96.6	95.4	89.9	90.8
	8	101.5	24.7	89.9	62.9	111.0
	9	40.8	36.3	93.8	111.9	110.8
	10	39.2	82.0	27.6	101.6	103.9
	11	88.7	59.5	95.3	88.2	76.7
	12	103.1	106.6	112.0	102.7	106.7
	13	64.4	80.5	124.3	68.0	51.6
M O D U L E -- 2	14	103.4	89.1	41.1	84.9	82.0
	15	51.2	53.4	43.7	135.2	47.1
	16	38.1	47.6	48.3	144.5	45.3
	17	97.5	52.0	50.4	44.5	31.5
	18	45.2	28.8	48.7	46.9	40.4
	19	41.1	33.9	46.9	32.3	46.3
	20	39.9	73.5	39.7	45.1	51.4
	21	56.6	42.4	120.5	60.6	121.5
	22	45.0	58.8	52.1	76.1	53.3
	23	50.2	40.8	45.4	38.0	51.3
	24	24.1	17.9	33.6	24.4	27.5
	25	47.0	27.7	35.5	39.7	34.2
	26	50.5	30.0	30.1	44.3	44.1
M O D U L E -- 3  outlet	27	58.2	43.9	64.9	48.1	65.8
	28	35.0	48.1	58.6	52.6	130.1
	29	65.6	47.9	55.9	46.9	121.4
	30	63.0	60.3	49.5	53.3	50.2
	31	128.1	53.8	63.9	54.3	58.8
	32	61.8	41.4	103.2	55.6	51.5
	33	99.0	79.8	83.5	46.5	42.0
	34	49.2	103.6	98.4	71.6	58.7
	35	65.5	61.0	50.1	59.6	55.2
	36	53.7	55.7	57.8	59.8	49.3
	37	54.4	120.2	63.1	49.3	55.5
	38	57.9	54.5	50.1	66.0	47.4
	39	50.4	39.8	49.0	47.2	43.0

The data were reviewed, and the heat pipes were divided into four categories.

### 1) Operational Heat Pipes

Twenty heat pipes exhibited a temperature drop of less than 35C; this is 10% of the total. These devices would be capable of operating nearly as designed in a HPBAC at normal operating conditions. A small amount of non-condensing gas may be present, but it should not significantly affect thermal performance.

### 2) Partially Operational Heat Pipes

One hundred five heat pipes exhibited a temperature drop between 35C and 65C; this is 54% of the total. These heat pipes would be capable of partially transferring heat by evaporation and condensation at normal operating conditions. However, there appears to be a measurable amount of non-condensing gas present in these devices – enough to degrade the thermal performance by an average of about 50%.

### 3) Significantly Degraded Heat Pipes

Thirty four heat pipes exhibited a temperature drop between 65C and 100C; this is 17% of the total. These heat pipes would be capable of transferring only a small amount of heat during normal operation in a BAC, e.g. 25%. The degradation in thermal performance for these cases would be nominally about 75%. The cause appears to be a large amount of non-condensing gas in the devices.

### 4) Non-Operational Heat Pipes

Thirty six heat pipes exhibited a temperature drop greater than 100C; this is 18% of the total. These devices are essentially non-operational, and would not be capable of transferring useful heat during normal operation of a BAC. Most of these cases appear to be caused either by the loss of their working fluid charge or by very large amounts of non-condensing gas.

Operational HP $\Delta T$ below 35 C (95F)	20 Heat Pipes	10 %
Partially Operational HP $\Delta T$ 35 C to 65 C (95F to 149F)	105 Heat Pipes	54%
Significantly Degraded HP $\Delta T$ 65C to 100C (149 F to 212 F)	34 Heat Pipes	17 %
Non-Operational HP $\Delta T$ Above 100 C (212 F)	36 Heat Pipes	18 %

In summary nearly 36% of the heat pipes are either non-operational or are significantly degraded from non-condensing gas generation. An additional 54% exhibited measurably degraded thermal performance. Collectively, this would result in an estimated 40% decrease in the effective heat transfer of the heat pipe tube bundle.

The work described in this section was provided to NSWC on March 30, 2007 in a report entitled Post Analysis Test Report (CLIN000101, Data item A001).

## 4. Redesign of HP-BAC

### 4.1 Reduction of Heat Pipe Thermal Resistance

#### 4.1.1 Analysis of Fabrication Procedures on Heat Pipe Thermal Resistance

A detailed review of the heat pipe fabrication procedure was conducted to determine the cause of the problem. The fabrication procedure used by subcontractor Advanced Cooling Technologies was scrutinized to identify procedural causes. Several items were identified that are believed to have collectively created the degraded condition of the heat pipes. First, the heat pipes were not operated at elevated temperatures before the sealing step. The procedure that was used included use of a roughing vacuum pump to degas the heat pipe; pinch/seal of the fill tube was done without operating each heat pipe beforehand. Thermacore experience has shown that copper/nickel alloys produce a compatible envelope for water heat pipes only after a short period of operation at a temperature exceeding the anticipated end-use operating environment. This was not done for the BAC heat pipes. Secondly, the fill tubes were not heated to 300C before pinching, which increases the chance of cracking the fill tube during the pinching step. Also, the design of the fill tubes and pinch/seal tooling did not follow best practice for cupro-nickel alloys. These practices include use of a thicker fill tube wall, pinch tooling with larger radii, and shorter tooling stops to prevent over-pinching should be incorporated into future fabrication procedures. Lastly, the heat pipes were not operated after pinch/seal to confirm that the pinch/seal was vacuum-tight. Collectively, these procedure processes would have created several potential conditions to degrade heat pipe performance, including entrapment of air, entrapment of hydrogen gas, and loss of water fluid charge during normal operation.

#### 4.1.2 Heat Pipe Redesign and Test

A study was conducted to identify a heat pipe design capable of effective operation in the bleed air cooler application with a thermal resistance of 0.06C/W or lower. Several design features were identified as being important to achieve the desired goal, including the working fluid charge, the wall material and thickness, and the wick design. It was concluded that a thinner wall 70/30 envelope would be required; preliminary calculations showed that if the maximum inlet air temperature rating on the bleed air cooler could be reduced to 700F, then a 700 lb class envelope material would be sufficient. Additionally, recent development work at Thermacore has demonstrated that internal heat pipe temperature can be controlled under supercritical conditions by limiting the working fluid charge placed in the devices.

The wick design can also affect thermal conductance, so candidate wick designs were identified and selected for comparative testing. Three heat pipes designs were selected. The first



Figure 2 Cu/Ni Heat Pipe Test Articles

design was a wickless thermo-siphon – the same design used in the previous bleed air cooler program. The second design used a sintered copper powder wick layer. The third design used a brazed copper/nickel felt layer. A working fluid charge of 10 grams was also selected. One of each of these designs was assembled and tested. Figure 2 shows a picture of the three test articles.

Each of the three test articles was operated under conditions representative of the bleed air cooler, as shown in Figure 3. The conditions included a nominal operating temperature of 175C, similar evaporator length, similar condenser length, 1000W or greater heat transport, and vertical orientation. Operation was maintained for a length of time sufficient to assure steady state conditions.

The results showed that the thin Cu/Ni felt wick design operated with a thermal resistance of 0.06C/W; the sintered powder wick design operated with a thermal resistance of 0.07C/W; and the plain tube design operated with a thermal resistance of 0.08C/W. The data recorded in the laboratory notebook included temperatures across the heat pipes, the water calorimeter data, and applied heat load. The conclusion from these tests is that the sintered felt wick layer should be used in heat pipes for this application. This design provides the lowest thermal resistance and allows operation with a reduced fluid charge. The sintered felt and sintered powder wick designs were placed on life test at Thermacore; after over 500 hours they exhibit no signs of gas generation at 200C.

These units were put on life test in June, 2007. This work was described in the report entitled *Reduction of Heat Pipe thermal Resistance* (CLIN000101, Data Item A002) which was provided to NSWC on June 30, 2007. Additional heat pipes were built and tested starting in September, 2007 which led to changes in the conclusions described here. These additional tests are described in Section 5 below.

## 4.2 Improved Fins and Fin Attachment

### 4.2.1 The Fin Attachment Problem

One of the shortcomings recognized in the prototype BAC, was the brazing of the fins to the heat pipes. The original fins were formed, but copper nickel does not draw very well. Figure 1 shows the shape of the fin collar and its impact on fit and braze.

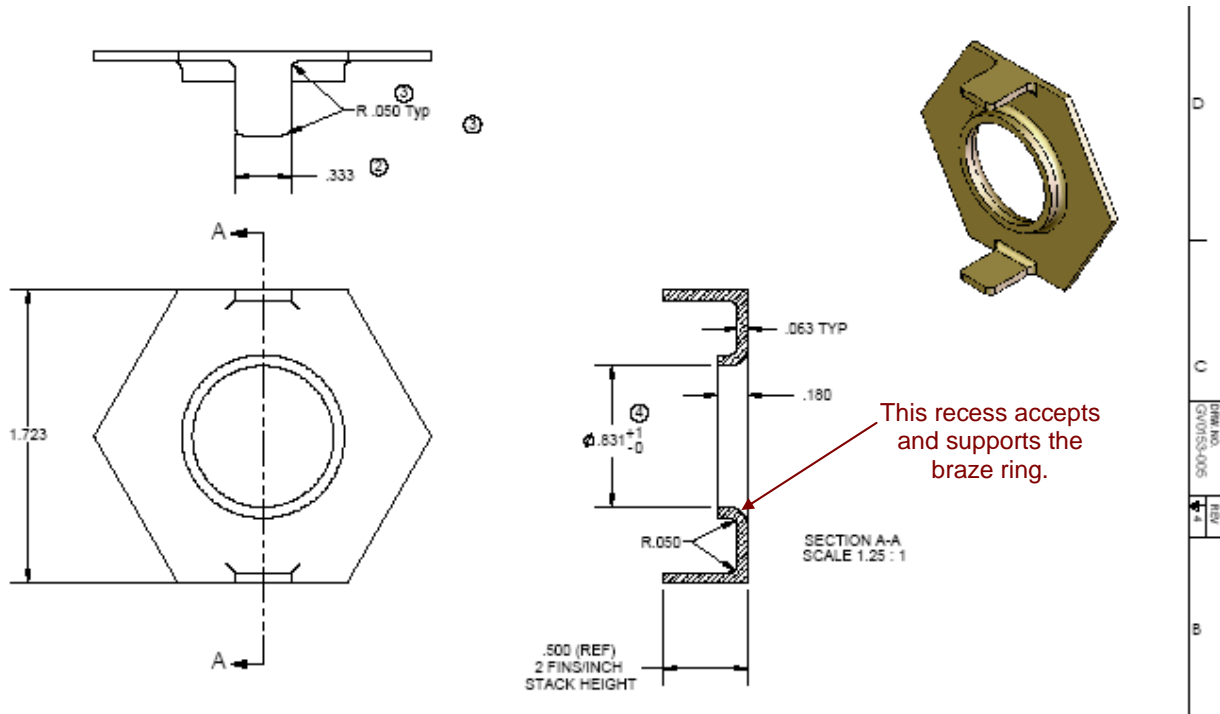
The direct contact between the collar and the heat pipe is limited to a very thin line (at the right in Figure 3). About two-thirds of the available contact length is occupied by thick braze material, and about one-third is simply void. The braze material is a poor conductor compared to the base copper-nickel, and the void is an insulator. The result is a very high thermal resistance between the fin and the heat pipe. This was identified and was specifically addressed as Item 3.4.4 of the present contract.



**Figure 3 Fin Braze Detail**  
from EWI Welding Report (N00014-02-C-0106)

#### 4.2.2 New Fin Design and Fabrication

Casting the fins would eliminate the forming problems and some cracking issues, but it was ultimately determined that only machining of the cast fins would provide an interface that would allow a truly effective braze joint. Vforge of Lakewood CO developed a casting technique and supplied the fins used to make test article heat pipes. Vforge was contracted by Advanced Technology Institute (ATI) of Charleston, SC to advance the development of semi-solid-material (SSM) casting technology in copper materials. ATI and Vforge have been working with NSWC and Thermacore to improve fin fit and performance. The contributions of Vforge and ATI to this effort are supported under the Copper-Based Casting Technology program, Cooperative Agreement W911NF-04-2-0008 between The Advanced Technology Institute (ATI and the U.S. Army Research Laboratory (ARL).



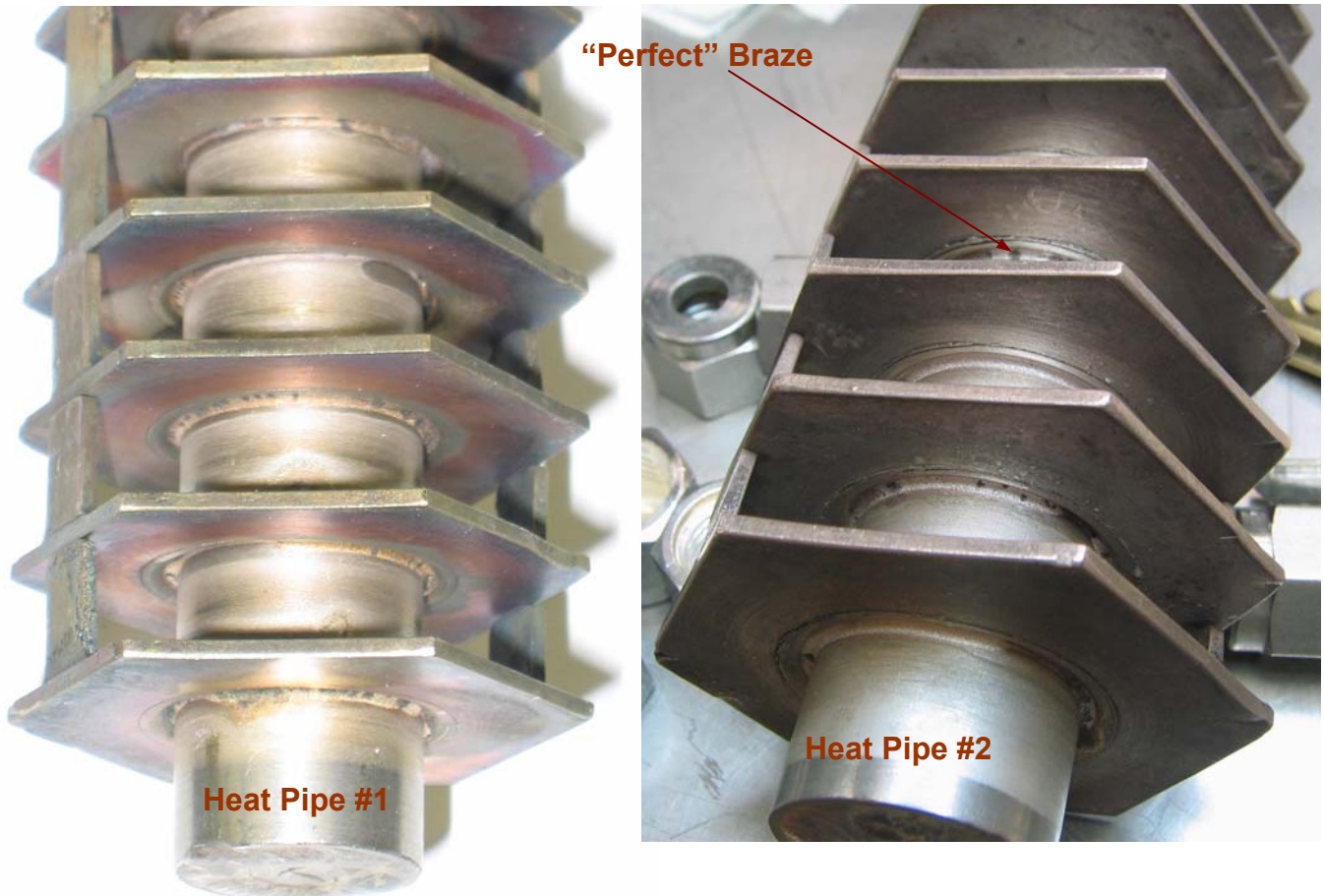
**Figure 4 Air Inlet Fin from Drawing GV0153-005**

The design of the air side inlet fin which was used for these heat pipes is shown in Figure 4 which is excerpted from drawing GV0153-005. Three features of this design should be noted. One is the incorporation of tabs on the side to permit the stacking of fins to provide the 2 fins/inch spacing required for the air inlet section. The second feature is the radius on the top (non tab side) which supports a ring of braze material. The third feature is the tolerancing on the ID of the fin. Combined with the tolerancing on the heat pipe shell, this sets the maximum gap that must be bridged by the braze. This ensures that there will be no voids between the fin and the heat pipe, and also minimized the thickness of the relatively poor conducting braze material.

The first set of fins received were out of spec. In order to proceed with fabrication, the heat pipe body was machined slightly smaller than specified so that the fins would fit over it. These first fins were slightly out of round, so that the maximum gap between fin and heat pipe exceeded

specification. Since the gap was still sufficiently small that capillary pressure would constrain the braze so it wouldn't drain from the joint, it would provide a good braze, and assembly proceeded with the fins on hand. The issue was discussed with Vforge. The out of tolerance was not related to the SSM casting process, but was a misunderstanding on their machining step, and was promptly resolved. The second set of fins were well within specifications, and produced beautiful brazes.

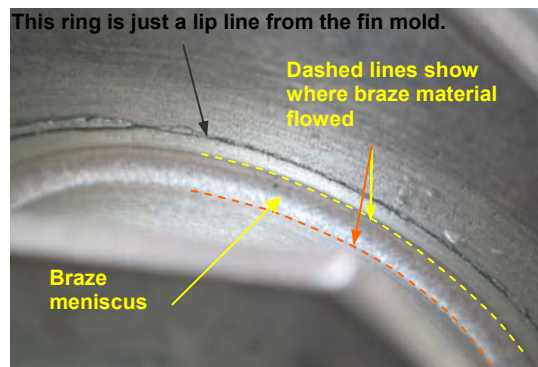
### 4.2.3 Braze Comparisons



**Figure 5 Fin Braze Images**

Heat Pipe #1 was fabricated using the out of spec fins. Heat Pipe #2 used the second set that were well within specifications. (Note: the # sign identifies a serial number that is engraved onto the pipe.) Figure 5 shows the fin braze results for the two heat pipes. Compare these brazes with the braze in Figure 3 to put the improvements in perspective.

Heat Pipe #1 yielded very good visual results; heat pipe #2 was slightly better. One consistent difference that can be seen by studying the images is that the braze fillets are slightly higher (i.e. closer to the plane



**Figure 6 Close-up View of Braze**

of the fin) for heat pipe #2. Since each braze rings contains the same amount of material, this indicates that there were less gaps to fill on heat pipe #2, and provides visual confirmation of the better fit of the fins.

Figure 6 gives a magnified close up view of the resulting braze. This is simply a beautiful braze.

#### 4.2.4 Fin to Heat Pipe Conductivity Test

Figure 7 shows the simple heater block used to evaluate the thermal connection of the fins and heat pipe. It encloses two 50 watt cartridge heaters. The test data was taken at a total power of 55 watts which corresponds to about 20% of the per-fin power when the BAC is at its design power of 425 kW.

The heater block clamps to the edge of the fin and has a slight lip that rests on a thin section of the top. Figure 8 shows a cross section of the heater block to illustrate how it is mounted and how the heat enters the fin. Figure 8 also shows the location of the two thermocouples. One is on the upper surface of the fin and is a conservative representation of the fin temperature.

The second t/c is mounted on the heat pipe wall just below the fin. Both are slightly embedded in shallow holes in the surfaces they are monitoring.

The temperature difference between these two points is primarily caused by the resistance of the coupling between the fin and the heat pipe. This delta-T is a quantitative measure of the thermal connection between fin and heat pipe.

##### 4.2.4.1 Conduction Test for Heat Pipe #1

The power was raised to an indicated 102 watts and the temperature at the fin rose to 200°C at which point the power was reduced to an indicated 54 watts. After 15 minutes the temperature had stabilized around 168° for the fin. Six data sets were taken over the next 45 minutes with random variations between them. The lowest delta-T recorded was 9.4 °C and the highest delta-T was 10.4 °C. The average was 9.87 °C.

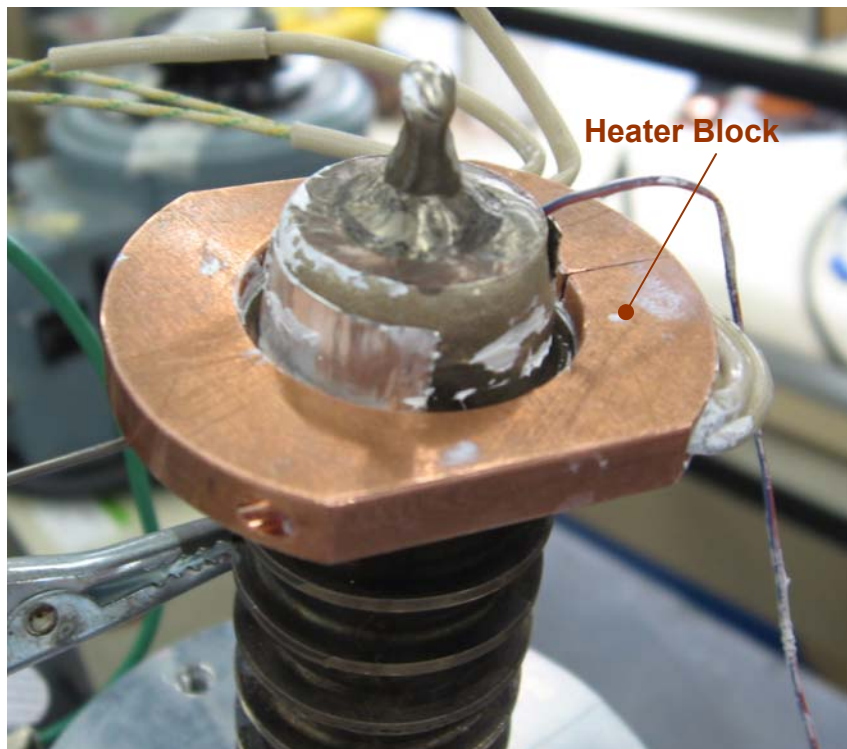


Figure 7 Fin Conductivity Test Setup

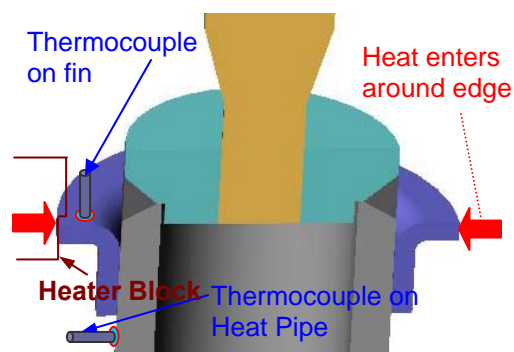


Figure 8 T/C's and Heat Input

#### 4.2.4.2 Conduction Test for Heat Pipe #195 from the Unsuccessful Prototype BAC

The test was repeated on a heat pipe from the existing bleed air cooler to quantify the improvement from the new fins and brazing. Heat pipe #195 was tested because it was the most accessible, located at the corner of the heat pipe array. The fin and heat pipe were cleaned of corrosion and crud. The same preparation as for HP #1 was repeated, including drilling shallow holes (t/c wells) to fix the thermocouples and make sure their junction was inside the surface it was measuring. Thermal grease was used around the heater block and in the t/c wells. The same equipment from the HP#1 test was reused.

To warm things up, the power was initially set to an indicated 100 watts. The fin temperature rapidly shot up to 250°C so power was lowered to an indicated 55 W. Temperature lowered then crept back up. As expected for a conduction measurement, the delta-T remained reasonably constant as the fin temperature rose from 248.0°C to 259.7° over the next quarter hour. The average delta-T over this period was 62.05 °C.

#### 4.2.4.3 Conduction Test for Heat Pipe #2

The test was repeated on Heat Pipe #2 using the same equipment. At this time HP#2 was not charged so it was not working as a heat pipe. The power was initially set to 100 watts and when the fin temperature passed 200°C it was reduced to an indicated 55 Watts.

The fin temperature settled in the 228 to 230°C range. Five readings were taken that varied from 8.2 to 8.4 °C and averaged 8.32 °C.

It should be noted that HP#2 had 1.5 °C less delta-T than HP#1, or a 15.7% reduction. While the differences visible in Figure 6, may not be that apparent much less dramatic, a 15% reduction in delta-T is very significant.

### 4.2.5 Fin and Braze Conclusions

The new fin design reduced the thermal resistance from the fin to the heat pipe by a factor of five. This corresponded to a 50 °C reduction in delta-T at 20% of BAC design power. The improvement brought about by the SSM cast fins and the tighter tolerances and better brazes they enabled, exceeded the expectations of most parties involved. These measurement would indicate that the original fins played a larger part in the shortcomings of the prototype BAC than had been appreciated in the post analysis.

The conduction difference between HP#1 and HP #2 was 15.5%. HP #1 had slightly out of spec fin dimensions while HP#2 fins were well within specification. The 15.5% measured difference in conductance verifies the effectiveness of the specification tolerances.

This work was described in the report entitled *Improved Fin Attachment and Fin Count* (CLIN 000102, part of data item A002) which was initially provided to NSWC on September 28, 2007, and provided in final editorialized form on October 10, 2007.

## 5. Fabrication and Testing of Heat Pipes

### 5.1 Heat Pipe Testing Index

More than 40 heat pipes were fabricated in the course of this work. Only 25 went into the engineering test unit BAC. A limited number were used for specific tests (e.g. hydro), or to test welding and pinch-off techniques. The rest were used to characterize and improve the heat pipe conductance. The following Heat Pipe Testing Index provides a brief summary of the heat pipe



construction and tests. This is presented as both documentation and as a guide to data that is officially ensconced in laboratory notebooks and data files.

### **5.1.1 Initial Thermal Resistance Pipes June 2007**

This group consisted of 1 bare tube thermosyphon, one pipe with sintered copper powder, and one pipe with brazed copper/nickel felt. These were described in Section 4.1.2 above.

### **5.1.2 Plated Felt Pipes - HPs #1 - #7**

These all used nickel plated copper felt. All were sintered in the belt furnace.

#### **Heat Pipe #1**

Used cast fins that were slightly out of spec.

Was fully processed and pinched off. It was tested using calorimeter can.

Best conductance was 7.5 W/K

#### **Heat Pipe #2**

Used plated felt.

Used second batch of fins that were in spec. 1 & 2 were basis of fin conductivity test and report.

Was tested using cooling coil. Best Conductance was 11.7 W/K

#### **Heat Pipe #3 (Charge Tests 10/15-10/25)**

This was tested without fins. Used the heater block with thru-the-block t/cs. Used copper coil for water cooling.

This pipe was clearly gassing. Continued over several days. 10/24 plot shows clearly.

#### **Heat Pipe #4**

This pipe was welded into a piece of plate, then had fins brazed on. It could not be pumped down. Crack was found at weld. Repair attempt produced much more cracking. It was sectioned by EDM.

This cracking was attributed to phosphorous from plating, that was not being removed by going thru the belt furnace. The led to decision to use vacuum sinter on subsequent pipes.

### **5.1.3 Transitional Heat Pipes HPs #“A” thru #“F”**

These pipes used a variety of wicks and tubing to determine what was causing the problems observed in the Plated Felt Pipes and correct it.

#### **Heat pipe “A”**

Machined from thick tubing to test if residual carbon steel was causing gassing. It had no wick or felt. 10/29 -10/30

Best Conductance was 32.0 W/K

Was welded into plate and taken to 10,000 psi

#### **Heat Pipe “B”**

Same as A but had electroplated wick. This pipe was eventually used for weld practice and welded into practice plate.

Showed severe signs of gassing as indicated by rising condenser dT. Started at 2.5 K, rose to 9 by next day and to 16 over weekend. Conductance declined from 30 to about 22.

Best conductance 30.9 W/K.

#### **Life Test Pipe**

This is the felt wick pipe from 5.1.1 that was taken off the life test rack.

At 300 W the dT was about 11 K, after some effort with t/cs we got it down to 8.56. The latter was equivalent to conductance of 27 W/K.

**Heat Pipe “C”**

This used an unplated copper felt wick.

No gassing. Conductance was in 14-16 W/K region. Do not think the felt attached as well.

Pipe was eventually used for weld practice.

**Heat Pipe “D”**

Sintered “purple” powder. Best performing HP.

**1 Bare Pipe**

Initial testing of bare ( i.e. no fins) pipe with copper coil cooling and standard heater block gave conductance values in 65 to 69 W/K range.

**2 With Fins**

Pipe had fins brazed to it. Initial testing based on FCS setup gave ~ 6 W/K. After CSS set it up like #1, the best measured conductance was 32.7 W/K.

**3 Pinched off with Cooling Can not Coil**

When fully processed, which allowed the use of the cooling can rather than the coil, HP “D” recorded 57.2 W/K at 555 watts by calorimeter.

**Heat Pipe “E”**

Heat Pipe E was sintered purple powder. It was welded into a plate section, then had fins brazed on. It was processed using the end heater block which is how we will process the test article. It was instrumented with t/cs mounted as they will be in test article. Initial values were 10.9 W/K. Throwing out the condenser top t/c gave 14.4 W/K. Subsequent playing with t/cs, burping etc, gave max of 10.0/12.6 W/K.

This is pipe that was burst test. It popped at 12,600 psi.

**Pipes “F” and “G”**

These were sintered in same batch with “E”. Had fins brazed on. These were to be deliverable samples. These were used in the Engineering Test Unit HP-BAC.

**5.1.4 Test Plate Pipes****Heat Pipe #03**

This was the downstream back corner pipe, fully welded into the full baseplate. This pipe was bare, i.e. no fins.

Tested on the baseplate at 105 W indicated by water flow, using the same heater block with it showed a conductance of only 1.03 W/K

**Heat Pipe #19**

This pipe was adjacent to #03 at rear of downstream row.

**1 In Plate**

This was measured in plate adjacent to #03. It had only been lightly tacked to the plate. With same conditions as #03 It carried 294 watts by water flow at conductance of 3.05 W/K. This was tested the following day with various modifications to t/c and attachments but continued to measure close to 3 W/K. This is about a factor of three better than the welded pipe.

**2 On Bench**

When tested on bench it had a different cooling coil to allow more t/cs. The closest correlation to the in-plate test gave 9.4 W/K on Sat and 14.3 W/K on Monday, about a factor of 3 better than in the plate.

**3 On Bench w/new plungers (Jan 2)**

This was retested using the new thermocouple plungers used on #18. Measured conductances were 20.0 and 20.8 W/K. This had the lowest wall temperatures recorded so far, which indicates good attachment of the cooling coil.

4 With split heater block, countersunk plungers (Jan 3)

With improved heater block and thermocouple isolation the heat pipe conductance was 27.4 W/K.

### Heat Pipe #18

The thermocouple plungers were replaced before testing this pipe.

1 On Bench, un-welded

The pipe was removed from the plate and tested. Conductance measured was 16 W/K. Actual results (all t/cs) were 17.0, 17.0, 15.5, 16.0, 16.0, and 16.0 W/K. The last test was after sitting overnight).

2 After Weld into sample plate

The heat pipe was welded into a roughly 2 inch square section of 1¼" plate. The conductance apparently improved to 21.75 W/K. Test values were 21.5, 22.0 and 21.75 W/K.

3 After higher Energy Weld

Because of the small sample size and non restricted access to the weld, the welding was accomplished with less heating than would take place welding into the real baseplate. The welding was repeated with a deliberate effort to perform a higher energy weld that involved at least as severe heating as would occur under restricted conditions.

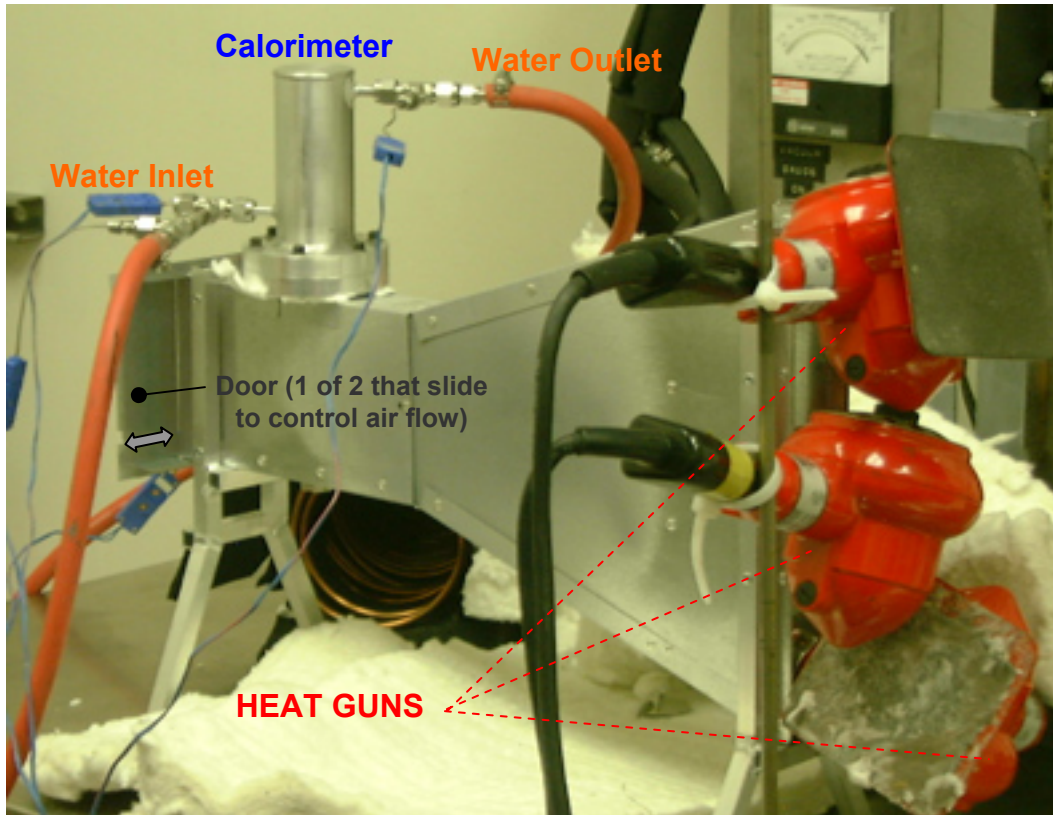
The conductance decreased to 18 W/K. Actual values were 17.4, 18.0 and 18.1 W/K.

## 5.2 Decisive Heat Pipe Tests

This section describes the definitive heat pipe tests that led to program decision or which became standards for on going measurements.

Figure 9 shows the test setup prior to installation of insulation. The heat pipe condenser has been enclosed in a water jacket instrumented to serve as a calorimeter. This test unit can only be used with fully processed pipes. Heat pipes that have not been pinched off will not fit within the calorimeter can. The water flow, and the inlet and outlet temperatures, measure the power actually transmitted by the heat pipe.

The design of this test setup first considered airflow. The shipboard tests were up to 1750 scfm which is approximately 10 cfm per heat pipe. The heat guns can deliver almost 1750 watts each and deliver up to 700°C temperatures. Their flow rate was measured using a flowmeter and found to be 10.5 cfm through the flowmeter. Three heat guns would therefore provide more than sufficient airflow that could be throttled by the sliding doors on the outlet of the duct.



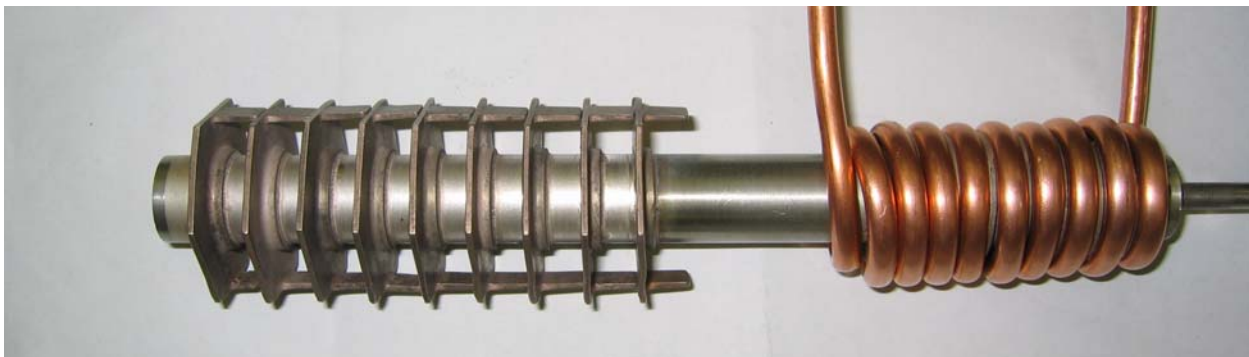
**Figure 9 Test Setup for Pinched-off Heat Pipes**

### 5.2.1. Heat Pipes #1 and #2

These heat pipes were built primarily to test the effectiveness of fin design and brazing, and the results of that testing were described in Section 4.2.3 above.

These were built of thick walled tube (class 3300, 70/30 Cu/Ni tubing as defined in MIL-T-16420) because it was available in a timely manner.

Heat pipe #1 was fully processed so it could be tested in the test stand shown in Figure 9. Using the water calorimetry, the assembly was transporting 650 watts. The best value of conductance was  $7.5 \text{ W/}^\circ\text{C}$  which corresponds to a thermal resistance of  $0.133 \text{ }^\circ\text{C/watt}$ . This is about half the conductance, or twice the resistance, that was used in the HP-BAC design.



**Figure 10 HP#2 Showing Water Cooling Coil**

Heat Pipe #2 was being used to optimize the fluid charge, so it was not pinched off. The air-side was inserted into the hot air stream of the Figure 9 test setup, but the water side did not have fins and was cooled using a water cooling coil as shown in Figure 10. The best conductance value for #2 was  $11.7 \text{ W/}^\circ\text{C}$  which corresponds to  $0.085 \text{ }^\circ\text{C/watt}$ .

### 5.2.2. Heat Pipe #3 - Gassing

Heat pipe #3 was being used to optimize the fluid charge in the pipe. Generally the pipe is overcharged, and fluid is vented until the delta-T is minimized. In the course of this work, it became very apparent that the heat pipe was generating non-condensable gas. This is evident by two separate observations.

Fluid is vented into a graduated syringe. Generally the fluid is vented as vapor. It pushes the plunger up with a vapor space above the liquid. After the vapor condenses, the amount of liquid in the syringe is directly measured from the markings and the amount that has been vented from the heat pipe is then know. During the tests on HP#3, the space in the syringe above the liquid would not condense, and was growing with time. This is direct observation that non-condensable gas (NCG) was being generated in the heat pipe.

The other observable effect of NCG is an increase in the delta-T of the heat pipe. (It is this effect that makes NCG a bad thing.) Both effects were being observed over several days of testing, but the definitive delta-T effect is presented in Figure 11. The basic image was generated at the time of testing by joining two screen shots from the LabView data logging program, adding notes, and pasting in the lab book. The figure was created by scanning from the lab book. The callouts in white were added in this report. The green line is the temperature at the outside wall of the heat pipe at the top of the condenser and the rust colored line is the temperature at the bottom of the condenser.

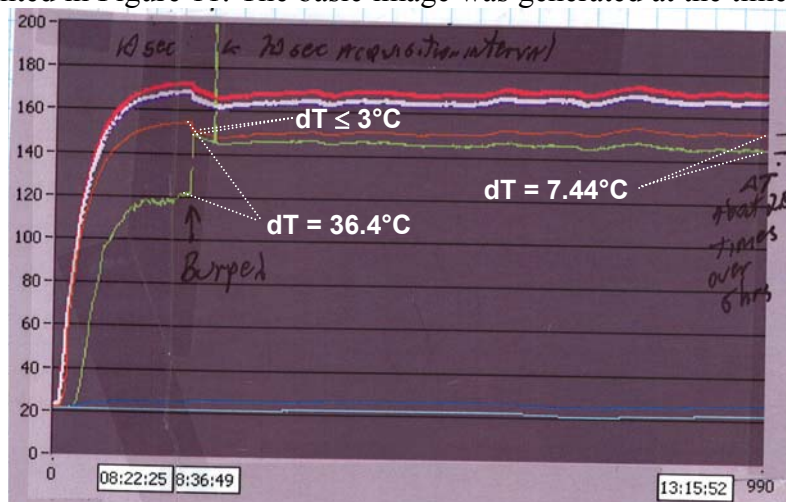


Figure 11 Screen-shot of 10/24/08 Test Data

When the test was shut down at 5 pm on the previous evening, the difference between these readings was  $11.2^\circ\text{C}$ . As shown on Figure 11, when the heat pipe reached steady state the following morning this temperature difference had risen to  $36.4^\circ$ . The pipe was “burped” at 8:52, and this delta-T immediately diminished to less than  $3^\circ\text{C}$ . The lab book documents that the syringe readings show that 3.6 cc of NCG were released during this venting. The test was run continuously for until mid afternoon. When data was next taken (2:15) the delta-T had risen to  $7.44^\circ\text{C}$ , an increase of 2.5 times over a 4 hour period.

Heat pipe #3 gave unequivocal evidence of gassing. This led to the fabrication of heat pipes “A” thru “C” to isolate and cure the gassing problem in the felt pipes.

### 5.2.3 Heat Pipe #4 – Weld Cracking

HP#4 was the first to investigate the effects that welding into the plate would have on the heat pipe. It was welded into a 1-1/4” thick piece of Cu-Ni plate to simulate the HP-BAC baseplate. It

could not be pumped down. Cracking was found at the weld. Attempts to repair the small cracks produced more extensive cracking. Welding of this material had not produced cracking in previous heat pipes. Something was embrittling the weld.

This cracking was ultimately attributed to phosphorus in the plating, combined with a change in processing. HP#4 had been sintered by passing through the belt furnace which is used to sinter commercial copper/water heat pipes. Other pipes had been sintered in a vacuum furnace. The vacuum furnace is a batch process; heat pipes are loaded, the furnace is brought to temperature, held for sinter time, then allowed to cool. The belt furnace has pipes fed to it continuously and uses a controlled hydrogen environment to control oxidation. The vacuum furnace was vaporizing and pumping out any remaining phosphorus whereas the 1 atmosphere hydrogen environment was retaining sufficient phosphorus to affect the welds. This led to a decision to use vacuum sinter on all subsequent pipes.

Heat pipe #4 was subsequently sectioned by EDM to show details of fin brazes and details of the welds and repairs. The sectioned pipe is shown on the right side of Figure 12.



**Figure 12 Heat Pipes #4 and “A”**

## 5.2.4 Transitional Heat Pipes to Diagnose & Resolve Gassing.

### 5.2.4.1 Heat Pipe “A”

These early heat pipes were being machined from thick tubing, and one theory was that residual carbon steel from the machine tools was being smeared or embedded on the inside wall and subsequently reacting with the water to produce the gassing. Heat pipe “A” was machined, but had no wick or felt. It produced no NCD, which laid to rest the theory that gassing was the result of machine tool residue.

The best conductance measured on this heat pipe was 32.0 W/K. This pipe was subsequently welded into a piece of plate and hydro tested to 10,000 psi. to confirm the integrity of the weld to the plate. It is shown on the left side of Figure 12 after hydro testing.

### 5.2.4.2 Heat Pipe “B”

This was identical to “A” but had an electroplated felt wick. It showed severe gassing. When first tested the condenser delta-T was 2.5°C. The next day it had risen to 9°C, and over the weekend it rose to 16°C. Conductance declined from 30.9 W/K to 22 W/K over this period. This pipe was subsequently used for weld practice.

### 5.2.4.3 The Life Test Heat Pipe

This is the felt heat pipe that had been put on life test back in June, 2007. It was removed from the rack and tested in the same manner as “A” and “B”. Its best measured conductance was 35.0 W/K. It had not gassed during almost six months on life test and showed no signs of gassing during these tests.

### 5.2.4.4 Heat Pipe “C”

This pipe used an unplated copper felt wick. It did not gas. Conductance was about 15 W/K, which about half the value from the plated felts. It was concluded that the bare copper felt was not attaching to the heat pipe walls as well as the plated felts. This pipe was subsequently used for weld practice.

### 5.2.4.5 Sintered Powder Heat Pipes “D” thru “G”

These heat pipes had wicks sintered from copper powder. Heat Pipe “D” was the best performing HP that was individually tested during the entire program; its best value was 69 W/K before the fins were brazed on, and it achieved 57.2 W/K at 555 watts in the most definitive test. This pipe and its performance are discussed in the test analysis part of this report (Section {} ). All the sintered pipes worked well and did not gas.

### 5.2.4.6 Conclusions from Gassing Tests

The gassing was clearly associated with the plated felt since it did not occur in bare pipe or pipes with sintered powder. However, the fact that the life test pipe, which had been plated six months earlier than the others, did not exhibit gassing, indicated the problem was not inherent to the plated felt.

It was concluded that the problem was most probably due to some contamination in the plating bath. The plating is done by an external vendor and the bath may pick up other metal ions from other work. Special cleaning or virgin bath chemicals would solve the problem, but since the current sintered powder pipes were out-performing the plated felt pipes, the decision was made to use sintered powder for future pipes. The entire sintering process is under Thermacore’s direct control.

## 5.2.5 The HP-BAC Test Article Heat Pipes

Heat pipes #01 thru #27 were fabricated for installation into the baseplate and test article. Figure 13 shows the initial heat pipe locations. The numbering sequence is also the order in which the heat pipes are welded into the plate in order to minimize stresses in the plate. Heat pipes “F” and “G” were installed in positions 24 and 25 and HP’s #26 and #27 went into position 18 and 19 respectively. All pipes were tack welded into position on the baseplate as bare heat pipes, i.e. no fins.

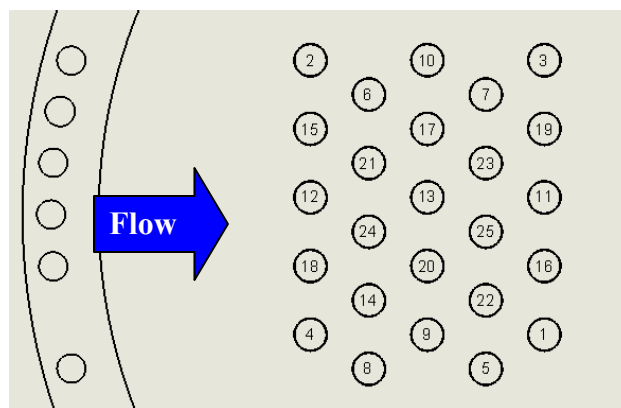


Figure 13 Heat Pipe Locations

### 5.2.5.1 Heat Pipe #03

Heat pipe #3 was fully welded into the baseplate. It was tested in the plate. Only 105 watts was transported by the heat pipe, as measured by the water flow and temperature change on its condenser side. HP#3 measured a very paltry conductance of only 1.03 W/K. This was thought to be primarily a measurement

error, as most of the heat was going into the huge baseplate, both as sensible heating and as a huge fin. Subsequent tests explored this hypothesis.

#### **5.2.5.2 Heat Pipe #19**

HP#19 was located next to HP#3 (see figure 13), but, it was only lightly tack welded to the baseplate. When tested in-situ under the same conditions as HP#3, it transported 294 watts with a conductance of 3.05 W/K. This is about 3 times better than HP#3 and is consistent with the reduced heat flow into the baseplate based on its small tack welds rather than the full welds of #3. The tack welds were then ground so it could be tested at the bench under more controlled conditions.

For the bench test a new cooling coil was used which allowed more thermocouples to be placed on the condenser. In the closest correlation to the in-plate tests, the measured conductance was 14.3 W/K. It was later retested using countersunk thermocouple plungers which give a reading that is more representative of the heat pipe wall and thus more accurate values for heat pipe performance. This yielded conductance values of 20.3 and 20.8 W/K.

#### **5.2.5.3 Heat Pipe #18**

HP#18 was removed from the plate and tested at the bench using the countersunk thermocouples. Conductance values from 15.5 to 17.0 W/°C were measured.

To see if the heat from the welding itself was somehow degrading the heat pipe performance, HP#18 was then welded into a roughly 2 inch square section of 1¼" thick plate. The conductance apparently improved to 21.75 W/K.

Because of the small sample mass, and the unrestricted access to the pipe while making the weld, the welding was accomplished with less heating than it would see if it were welded into the actual baseplate. The welding was repeated with a deliberate effort to perform a higher energy weld that involved at least as severe heating as would occur under the restricted conditions on the actual plate. After the re-weld, the measured conductance decreased slightly to 18 W/K.

#### **5.2.5.4 Conclusion**

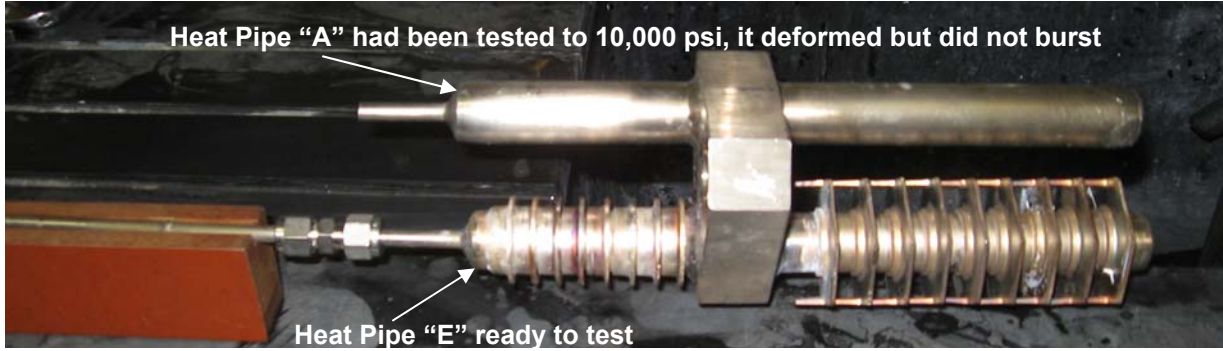
These heat pipes were performing well above the level that had been assumed for the design of the HP-BAC (conductivity of 14 W/K). The low conductivities that were measured when the heat pipes were welded into the baseplate were due to the thermal effect of the massive baseplate (as both a fin and a thermal mass), and to instrumentation errors related to the lack of access and congested conditions for the installed heat pipes.

### **5.3 Hydrostatic Tests**

Two hydrostatic tests were conducted. The first was conducted on Heat Pipe "A" in the bare configuration, welded into a plate to test weld integrity. It was taken to 10,000 psi. on 11/16/07. It distorted but did not burst. It is shown at the top of Figure 14 a.

The fully finned Heat Pipe "E" (which was welded into the same plate section as HP"A") was tested on 12/5/07. It burst at 12,600 psi. The test results are documented in Figure 14. Figure 14(a) shows HP "E" at 10,000 psi; distortion is evident, but the fins impart rigidity and it did not distort as much as "A" at this pressure. In Figure 14(e) the tube is ballooning between fins. Figure 14(d) shows cracks in the water side fins. It is conjectured that the first crack in the air side fins, which are cast and more brittle than the tube, allowed the sudden expansion of the tube and precipitated the burst.





Heat Pipe "A" had been tested to 10,000 psi, it deformed but did not burst

Heat Pipe "E" ready to test

(a) Photo with Heat Pipe "E" at 10,000 psi.

(b) Air side after test



(c) Closeup of burst region



Bulge Between Fins

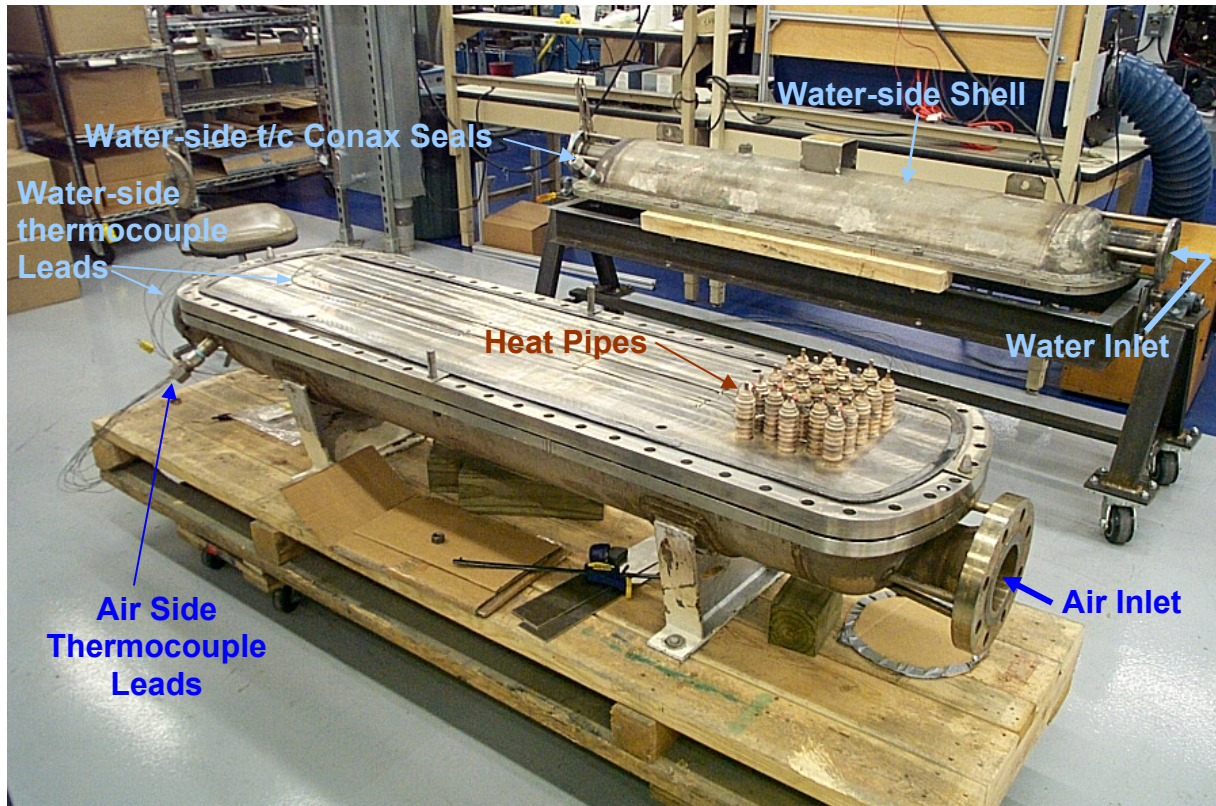
Burst at 12,600 psi

(d) Cracks in waterside fins



Figure 14 Hydrostatic Testing Photos

## 6. Design and Fabrication of HP-BAC Engineering Test Unit

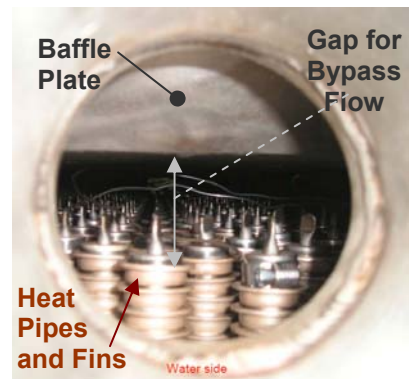


**Figure 15 Heat Pipe- Bleed Air Cooler Engineering Test Unit**

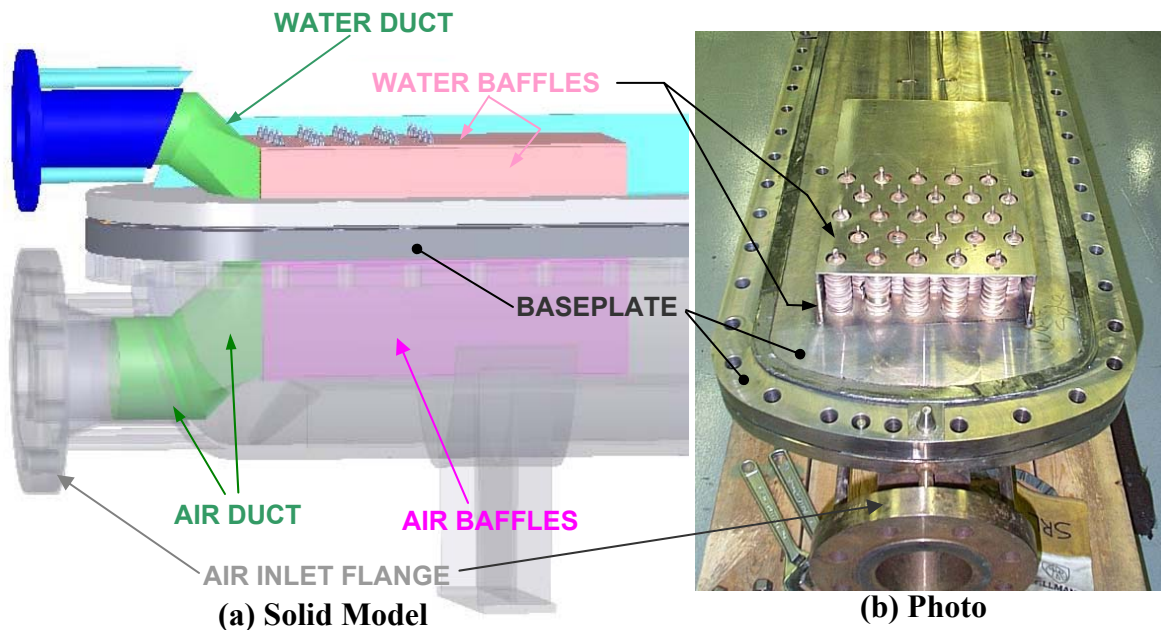
Figure 15 shows the HP-BAC just prior to installation of ducts and baffles on the water side of the unit.

### 6.1 Ducts and Baffles.

One of the major shortcomings of the BAC tested aboard the Ramage was the extensive bypass flow. Both the air and the water were able to flow around, rather than through, the heat pipes and fins. Figure 16 is a photo of the shipboard test unit taken through the water inlet. The large gap between the finned heat pipes and the baffle plates dominates the flow path. Since the gap represent a much lower flow resistance than the convoluted path between the fins and the heat pipes, most of the flow will take this easier path. This not only reduces the available coolant, but also reduces the fluid velocity over the fins with a consequent reduction in heat transfer coefficient. This bypass flow was recognized as a major cause of the shortfall in performance on the shipboard tests. A major objective of the present test unit was to eliminate the bypass flow so the actual flow would conform to the assumptions included in the HP-BAC analytical model.



**Figure 16 Gap for Bypass Flow (Shipboard unit)**

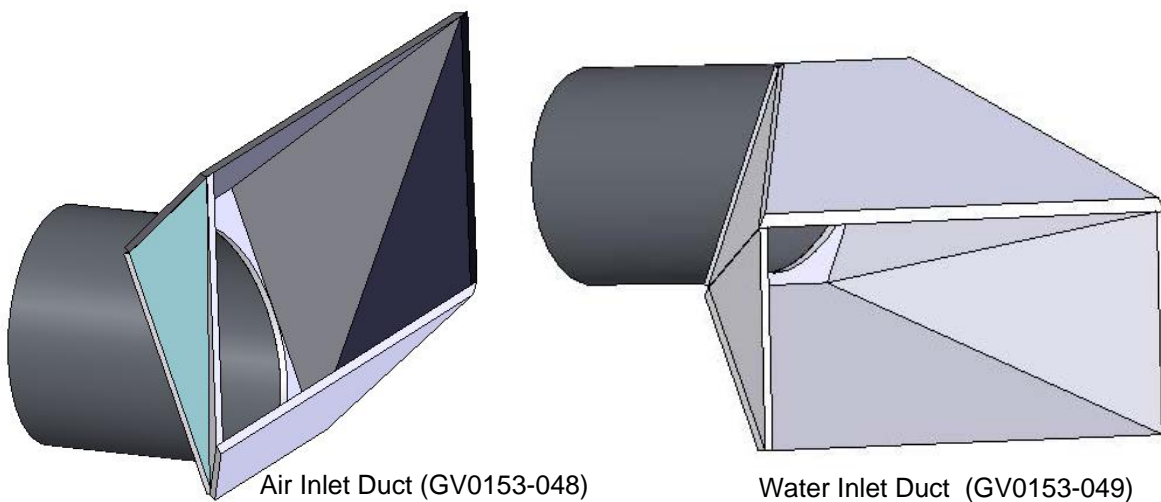


**Figure 17 Ducts and Baffles**

A system of ducts and baffles were designed to constrain the flow so it had to travel through the fins. Figure 17 shows the configuration of the ducts and baffles. The baffles channel the flow tightly around the finned heat pipes. The ducts direct the flow from the inlets to the baffled channels. Figure 17a is an image from the solid model with the air side shell transparent and the water side shell invisible. Figure 17b is a photo of the water side baffles.

The arrangement of the inlet flanges was dictated by the desire to make the HP-BAC similar in size and arrangement to the existing shell-and-tube BACs. As a result, the inlets are not aligned with the fins and heat pipes, and the flow paths are complex. The complexity of the ducts is increased by the need to utilize existing shells for the engineering model. Figure 18 shows the complexity of the ducts.

The baffles are copper-nickel and are welded to the copper nickel-baseplate. The ducts are of stainless steel. They inserted into the inlets but not attached until after the baseplate, including heat pipes and baffles, is installed into the shells. The ducts have some freedom of motion so



**Figure 18 Air and Water Inlet Ducts**

they can provide clearance during the installation. Once the baseplate is installed, the ducts are slid out to make a contiguous flow path with the baffles, and the ducts are welded to the shells by access through the inlets.

Although the heat pipes and fins occupy a small percentage of the internal volume of the BAC, the ducts and baffles ensure that almost all of the inlet flow goes through the fins and heat pipes, and conforms to the parameters in the analytical model.

## **6.2 Heat Pipe Processing**

The poor performance on the shipboard tests led to the heat pipe testing described in Section 5, and this led to very significant changes in the installation and processing of the heat pipes into the bleed air cooler.

### **6.3.1 Background - Conventional Copper/Water Heat Pipes**

Thermacore has produced many millions of conventional copper/water heat pipes at nominal cost. They are processed in largely automatic fixtures with the following steps.

1. A measured amount of water is injected into the unsealed heat pipe.
2. The heat pipe is connected to a vacuum header for a measured time. This step causes the water to boil, and the escaping steam purges the pipe of air.
3. The pipe is heated which verifies its operation and causes any remaining non condensable gas (NCG) to accumulate at the cold end of the fill tube. The pipe is then “burped” which removes any remaining air or NCG.
4. The pipe is “pinched off”. A set of anvils, somewhat similar to wire cutter jaws, pinch the copper together so it is vacuum-tight and also cuts it off at that point. The clean copper actually cold welds together under this pressure so it is vacuum tight at this point, but a final step dips it in molten solder to ensure a durable seal.

The heat pipes in the HP-BAC are made of copper-nickel which is much more difficult to process.

### **6.3.2 Heat Pipes for The First Prototype**

The subcontractor for the first prototype HP-BAC attempted to adapt copper/water heat pipe techniques for the more complex and challenging processing of copper-nickel heat pipes which had already been installed into the 1 3/8” thick tube sheet. By measurement at Thermacore after the shipboard testing, only 10% of the processed heat pipes were fully functional (the detailed results of these measurements is presented in Section 3.2.2, above.) The process steps employed, and the shortcomings associated with them, are discussed below.

1. After injecting a measured amount of water, the heat pipe was connected to a vacuum header for a manually controlled period of time.
  - a. If the time is too brief, not all the air (NCG) is purged from the pipe. The NCG blocks the condenser and increases the thermal resistance of the heat pipe.
  - b. If the vacuum is applied for too long, too much water is removed from the pipe. This leads to partial dryout, and increased resistance.
2. The pinch-off was performed manually with a device resembling boltcutters. It was performed in a single compression step, with a single set of anvils.
  - a. The manual operation is not capable of exerting consistent pressure, nor of maintaining that pressure while the tube is cut and sealed. Air can leak in while the tube is being cut and welded.

- b. The copper nickel tube is too hard to be reliably pinched in a single stroke. The large deformations produce cracking.
  - c. Potential problems are increased when only a single set of anvils is used. Narrow, sharper anvils which produce a good seal, will concentrate stresses and make cracking more likely if they are used for the entire pinch. Wide, rounded anvils that do not concentrate stresses, are unlikely to produce a vacuum-tight pinchoff if they are used for the entire pinch.
  - d. The single anvil, single stroke pinch off is likely to leave areas that are not fully sealed, allowing air leakage when the tube is being welded, and produce cracking in the fill tube near the crimp. Partial cracks can be enlarged by residual stresses from the seal welding. Even the tiniest of cracks will allow leakage that disables the heat pipe operation. 18% of the pipes were found to perform no better than a piece of tubing.
3. The heat pipes were not heat tested and “burped”. Without a heat up test, there was no confirmation that the heat pipes were working. Without the “burping” any residual NCG that had not been removed by the vacuum purge, would remain in the pipe and degraded its performance. More than half the pipes were found to be partially degraded with about twice the thermal resistance as designed. Another 17% were found to be severely degraded with a thermal resistance three or more times higher than designed.

### 6.3.3 Upgraded Heat Pipe Design and Processing

To eliminate the problems described above, and to enable heat pipe performance to not only equal but to surpass the original design level, processing now follows the more demanding procedures used for high temperature liquid metal heat pipes. The changes are considered below:

1. A sintered wick was added. This improves the thermal conductance of the heat pipe. The original design was a pure thermosyphon with no wick structure. A less expensive felt wick was tried but did not work well.
2. The heat pipes are vacuum off-gassed for hours rather than seconds. After off-gassing the valves are closed and the vacuum connection is replaced by the calibrated syringes as shown in Figure 19. The (water) working fluid is then injected by slightly opening the

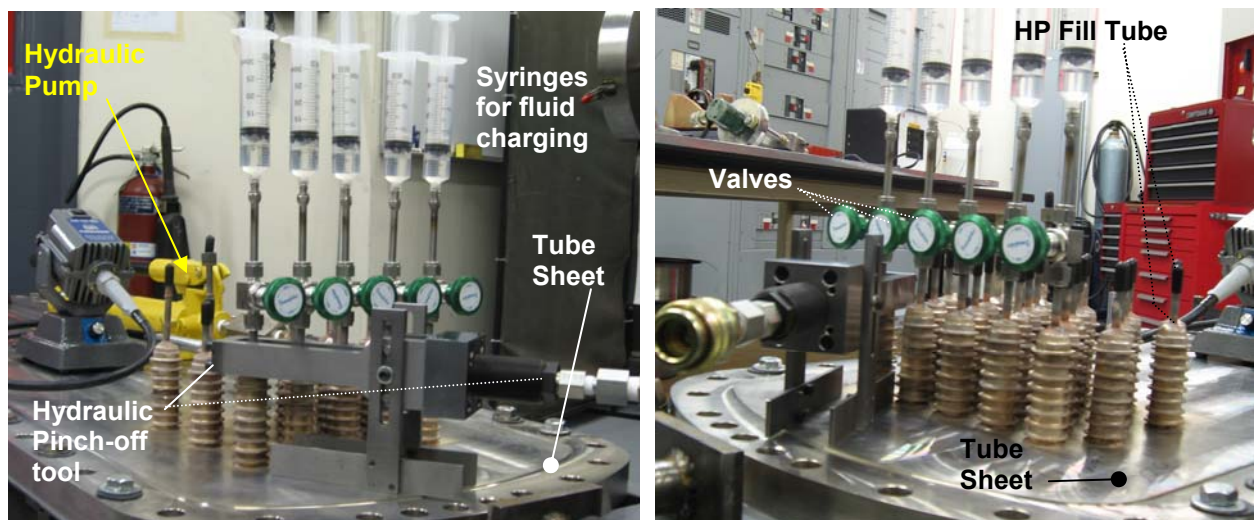
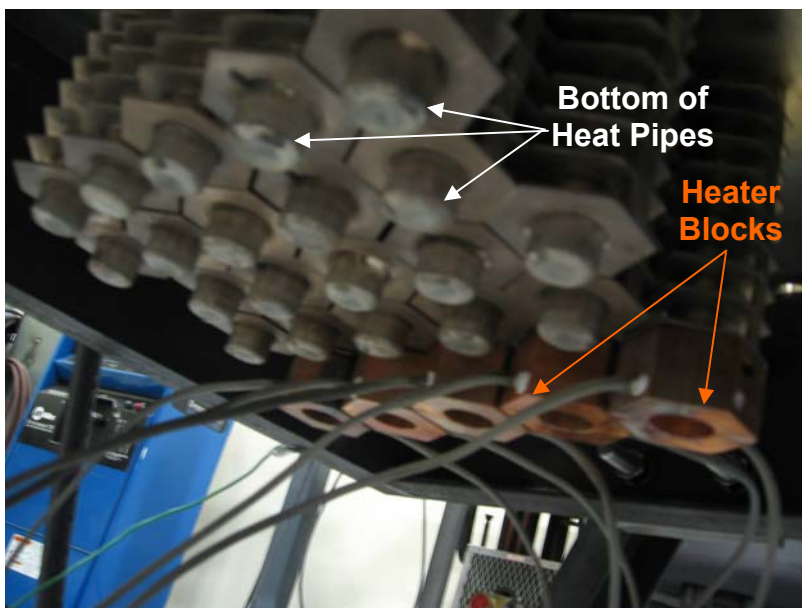


Figure 19 Processing Heat Pipes in Tube Sheet

valve and reading the level on the syringe. The heat pipes are never exposed to the environment after off-gassing.

3. After the fluid is injected, the evaporator portion (bottom) of the heat pipe is heated. This requires specially designed heater blocks that fit on the bottom of the closely spaced heat pipes as shown in Figure 20.

This power-up exercises the heat pipe and drives any remaining non-condensable gas to the coldest portion of the heat pipe which is the fill tube. Cracking the valve expels this NCG into the syringe. This is the “burping” process. The gas (if any) can be measured in the syringe, as can the amount of liquid that is expelled. Additional water can be injected if necessary to keep the charge within a narrow range. This process is very precisely controlled, unlike the timed vacuum previously used.



**Figure 20 Air Side of Tube Sheet showing Heater Blocks**

4. A hydraulic pinch off tool was designed and fabricated specifically for the HPBAC. Existing tools would not work due to the congestion of the closely spaced heat pipes. It is shown in Figure 19 positioned on a relatively accessible corner heat pipe but it can access any of the heat pipes. The test unit shown in Figures 15 and 17 had 25 heat pipes which are all the same length. The actual HP-BAC will include 195 heat pipes of differing lengths and will have even more difficult access.

The pinch-off is made more difficult by the need to change anvils halfway through the pinch-off cycle, a step that is necessary to minimize deformation and preclude cracking.

With the hydraulic tool, a constant pressure is maintained while the fill tube is cut and welded. The tool also maintains a fixed orientation of the anvils while this takes place.

At this time the heat pipes must be processed after they are welded into the tube sheet with the fins brazed on. The fin brazing is done in a furnace, and processed heat pipes would be over-pressurized at the brazing temperature.

5. The fill-tubes must still be cut off and welded closed. This requires two skilled people working together to accomplish within the congested working conditions entailed by heat pipes installed in the tube sheet.
6. After at least a day, the heat pipes are again energized with the heater blocks to confirm that no cracks, NCG, or other degradation has been introduced as a result of the pinch off.

Approaches have been identified which could lead to the heat pipes being processed at the bench prior to being installed into the baseplate, but this would require development (possibly Mantech

program?) and is far beyond what can be implement for the full scale test. A full description of the cost impact of the processing as well as potential cost improvements was provided in the Production Cost Analysis report submitted March 31, 2008 as CLIN000102, Data Item 006. A final version was submitted June 2, 2008.

The completed HP-BAC was shipped from Thermacore on March 20, 2008.

## 7 Testing

The full test report was submitted as CLIN000102, Data Item A003. In its final form it is dated August 12, 2008. The interested reader is referred to that report for a complete documentation of the testing performed.

### 7.1 Test Hardware and Facility

#### 7.1.1 The Engineering Test Unit

The contract refers to a “test coupon”, and much of the program communications refer to a “subscale test unit”, but all components are full sized and are installed in the shells that were used on the USS Ramage. The only manner in which the test unit is “subscale” is that it consists of the first 5 rows out of the 39 rows of heat pipes that would be installed on a fully loaded unit. Figure 15 shows the Bleed Air Cooler Engineering Test Unit with the water-side shell removed, and the 5 rows of heat pipes clearly visible. Figure 17 shows the ducts and baffles, and Section 6.1 describes them.

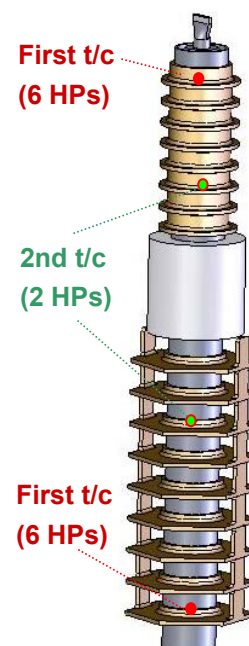
#### 7.1.2 Thermocouples

Instrumentation inside the shells consist of 16 Type K thermocouples. The number of thermocouples is limited by the Conax fittings which bring the t/c leads thru the pressure bearing shells of the BAC.

Figure 21 shows the thermocouple mounting locations on the heat pipes. Each of the six instrumented heat pipe has a thermocouple in the top fin on both the air and water sides. The inlet and outlet pipes had a second thermocouple mounted as shown. Holes were drilled through the base of the fin and the t/c tip was inserted into the hole so it was in contact with the heat pipe wall. The t/cs were bent to a narrow “L” shape so that a pipe clamp on the vertical part of the “L” could press the end of the t/c against the wall. The water side installation is shown in Figure 22. On the water side a piece of silicone rubber gasket (the red material in Figure 22) cushioned the t/c and provided some thermal insulation.

The air side temperatures were too high to allow the use of a rubbery material. The fins on the water side are very close together so they do not permit access to the thermocouple location on interior pipes. The fin was slotted to allow the t/c to nest in the pre-drilled hole in the fin base. The air side t/cs were bent into a narrower, taller “L” shape. The pipe clamp was applied to the long vertical part of the L clamping it to the exposed heat pipe wall at the bottom of Figure 21.

With access from the side, it was possible to attach a second thermocouple at an interior position on the inlet and outlet pipes.



**Figure 21**  
**t/c locations**

Thermocouple #3 on HP #15 is located on the inlet side of the heat pipe. All other thermocouples are located on the downstream side of the pipe.

Drawing GV0153-050-03 (attached below as Figure 23) identifies and locates the heat pipes as actually installed. Figure 23 also lists the thermocouple number(s) associated with each pipe.

The odd numbered thermocouples are on the air side, with even numbers on the water side. The heat pipe numbers are the serial numbers of the individual heat pipes. These are engraved on the base of the pipes; all fabrication records and in-house testing records, reference these numbers. The as-installed numbers are different than shown in Figure 13 above. Note that five instrumented pipes align to track a full flow stream from inlet to

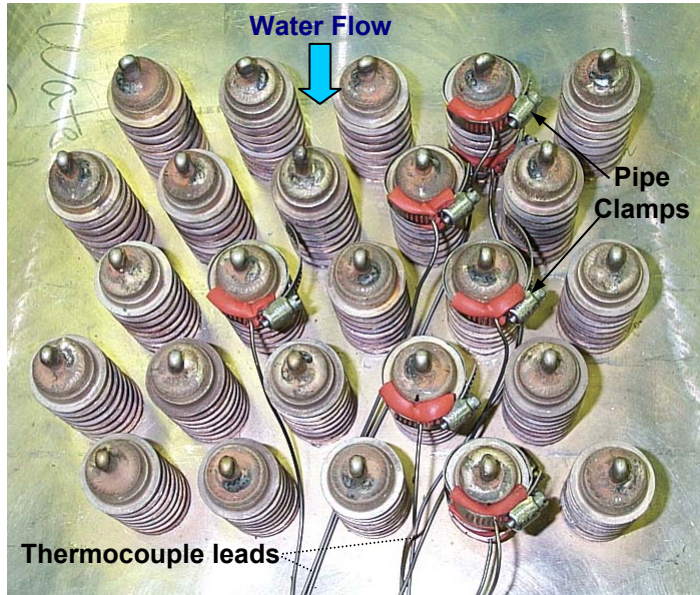


Figure 22 Waterside Thermocouple Mounting

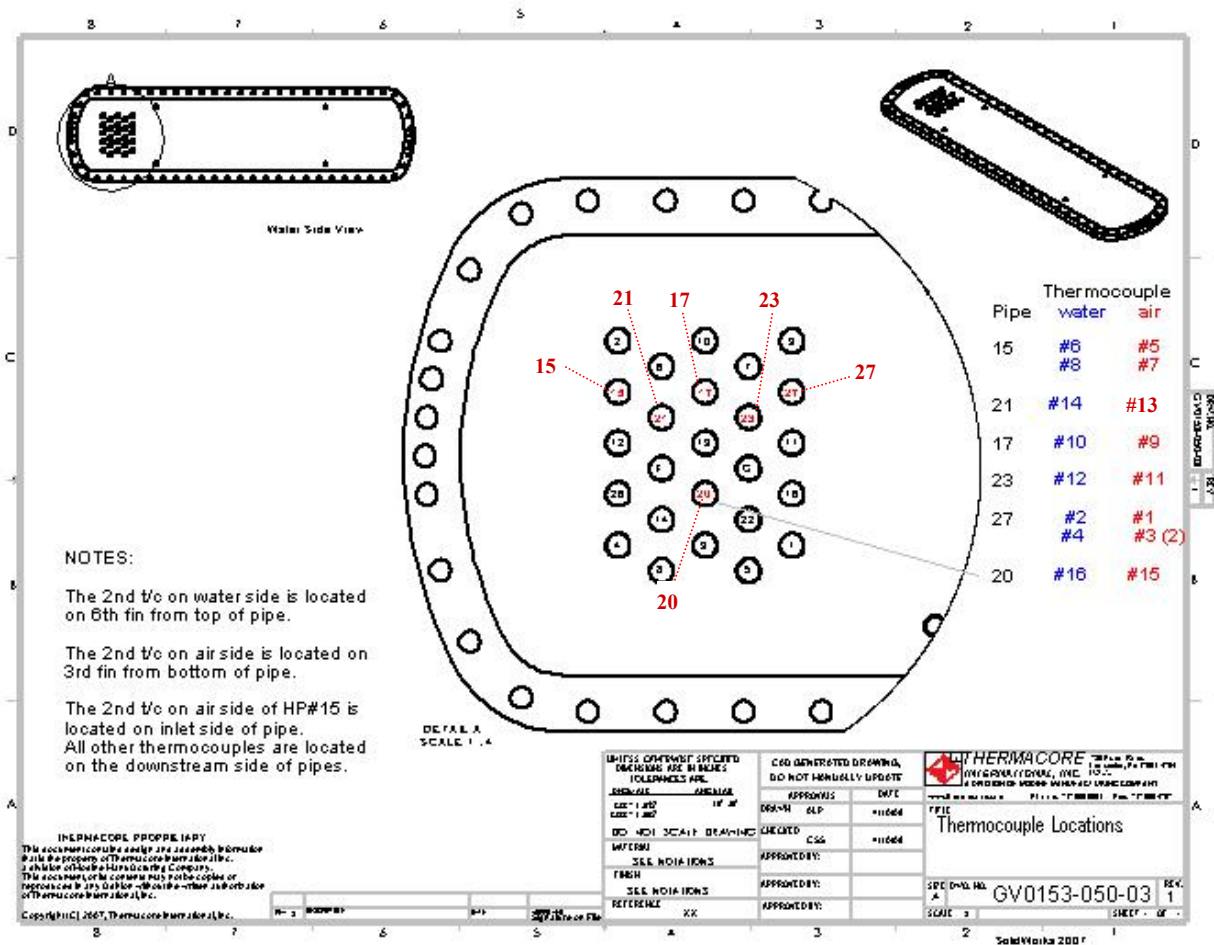


Figure 23 Heat Pipe Identification and Thermocouple Locations



outlet. Flow is from left to right in the figure, with the water side shown. One additional instrumented heat pipe is located in the interior of a symmetric row. The data logging sequence reflected the flow order of the heat pipes and t/cs.

### 7.1.3 Test Facility and Equipment

Testing was conducted at Wyle Laboratories, 128 Maryland Street, El Segundo CA 90245. Wyle was selected primarily because they had conducted the performance testing on the original Masker coolers back in 1988. Figures 24 through 27 are photos which show the test setup and related equipment.

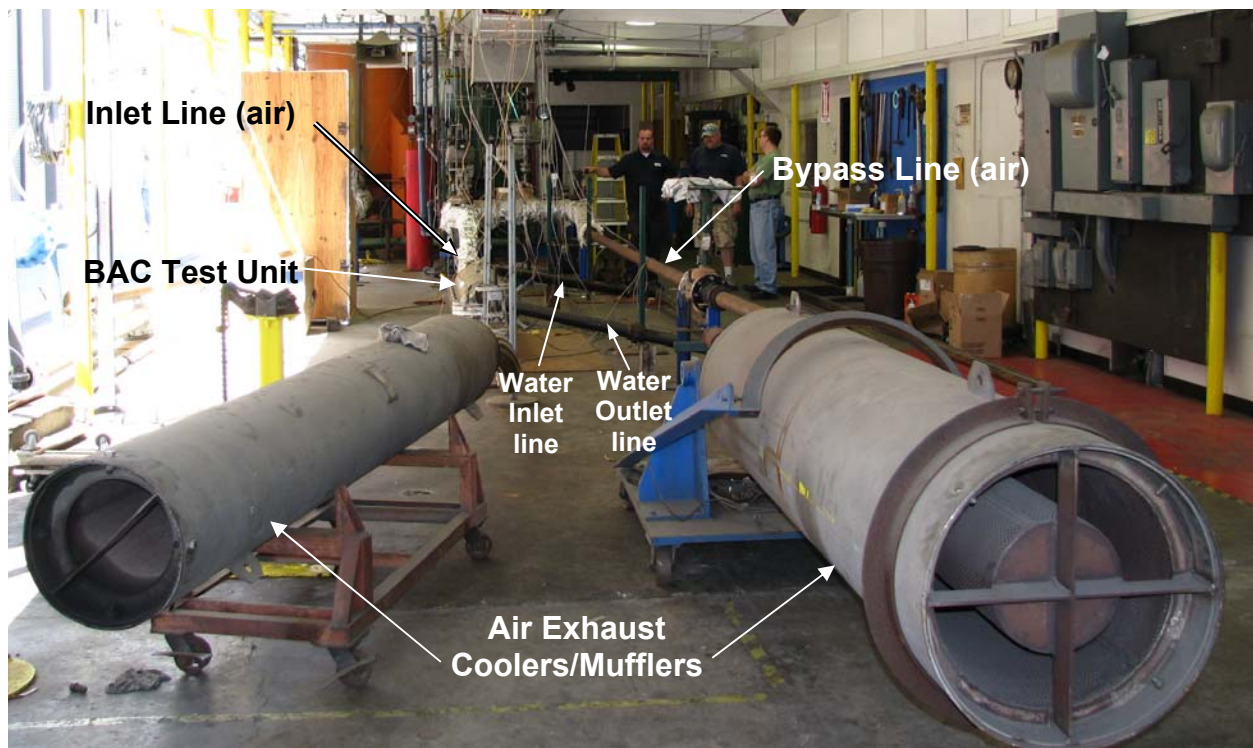


Figure 24 Setup at Wyle Labs Test Facility View from Air Exhaust Side

## 7.2. Test Objectives and Test Plan

### 7.2.1 Objectives

The basic objective was to verify and re-calibrate, the HP-BAC model.

#### 7.2.1.1 The HP-BAC Thermal Model

The thermal circuit consists of three resistance paths in series. There are the air side fins and pipe, the heat pipe itself, and the water side fins and pipe.

The air side heat transfer coefficient is calculated using the lower value of the Zhukauskas (1972) correlation for plain tube banks and the Briggs and Young (1963) correlation for individual circular fins. For the test conditions, these correlations differ by less than 0.7%.

The water side was based on Webb “Principles of Heat Transfer”, the Zukauskas correlation for finned tube banks, and geometric fine-tuning discussions between Dr. Wert of Thermacore and Michael Kuszewski at NSWC



Figure 25 Test Facility Air and Water Equipment Inlet Side

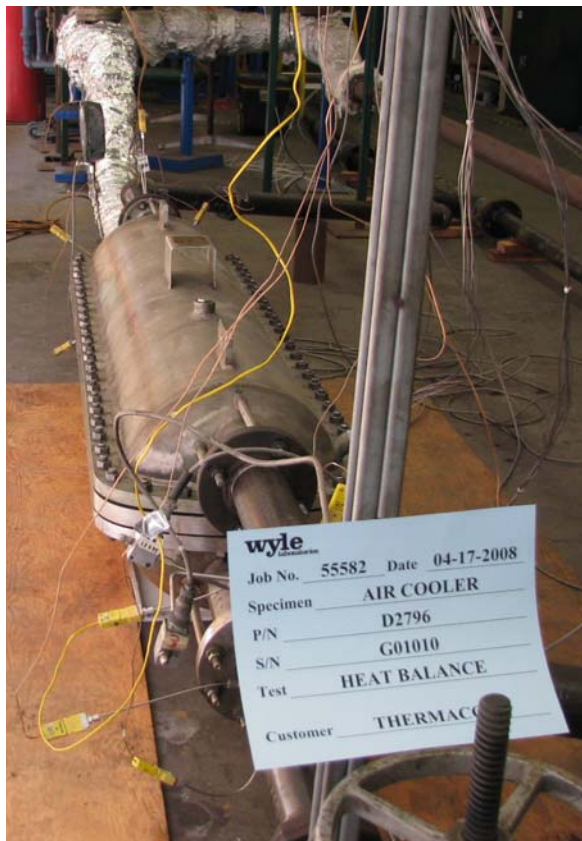


Figure 26 BAC in Test Loop



Figure 27 Heat Exchanger (outside)

The thermal resistance of the heat pipe is simply treated as an input parameter within the HP-BAC model. The HP-BAC design was based on heat pipe thermal resistance of 0.07 K/W. The instrumented heat pipes in the shipboard tests averaged 0.205 K/W, a factor of three higher than design.

Note that all heat exchanger calculations are based on correlations rather than closed-form solutions from first principles. Correlations vary depending upon exact configuration that was tested as compared to the configuration and conditions used to generate them.

## 7.2.2 Test Plan

The deficiencies identified or inferred from the shipboard tests (flow bypassing, fin attachment, and heat pipe performance) were addressed and corrected. The testing would confirm that the deficiencies were corrected and that the model predicts test results.

### 7.2.2.1 Test Conditions

The test conditions duplicate conditions for the Masker/SSGTG Starting Air Coolers performance tests. The major test parameters are:

#### Air Side

Flow	2450 SCFM (Navy SCFM is at 60°F)
Inlet Pressure	75 psig
Mass Flow	11,231 lb/hr (reference for 700°F)
Inlet Temperature	
Case 1	700°F (371°C)
Case 2	925°F

#### Water Side

Flow	90 gpm
Inlet Pressure	35 psig
Mass Flow	44,750 lb/hr (5.638 kg/sec at 90 gpm freshwater)
Inlet Temperature	85°F (29.4°C)

### 7.2.2.2 Instrumentation

The thermocouples are described in Section 7.1.2 above.

## 7.3. Test Results

### 7.3.1 Test Campaign Overview

Testing at Wyle Labs was scheduled to begin on April 15, 2008. Leakage on the graphite seals (which were re-used from shipboard tests) led to postponement. The first data was obtained on April 19. Failure of a booster pump did not allow a full data set to be obtained, but the data was analyzed and clearly showed that the HP-BAC was exceeding its calculated performance.

The first full data set was taken in test runs on May 12. This data clearly was in error, as the heat being removed by the water greatly exceeded the heat being lost by the air. This data was extensively analyzed and confirmed that the HP-BAC was performing better than calculated.

It should be noted that during the period between the April 19 and the May 12 tests, the Wyle engineer in charge of conducting the tests, Gary Krasnianski replaced Robin Christenson.

All the flow meters, etc were recalibrated. Several runs were made at Wyle to try to analyze the problem. Moving the water flow-meter further downstream from a control valve reduced the magnitude of the mismatch. A full data set was taken on May 30 and analyzed.

In facility testing, the Wyle engineer noticed that the air flow became reasonable at low temperatures but significantly understated the mass flow at higher temperatures. The air flow was being measured upstream of the heater, but the data logger was correcting for the density variation that would be necessary if the flow measurement was made downstream of the orifice. The correct massflow of the air was 42% higher than had been reported.

A test run on June 10 achieved a workable balance but did not achieve steady state operation.

A test run on June 12 took data on the 700°F air inlet condition only, so that it could run for a long period of time to assess drift and ensure steady state. This is the definitive data set for analysis.

A large number of individual heat pipes had previously been tested in a variety of configurations at Thermacore. This testing was described in Section 5 above.

The December 5, 2007 testing of HP “D” provided the most directly relevant measurements of heat pipe thermal resistance. The June 12, 2008 test run at Wyle Labs provided the definitive data set the full sacale testing. Only the results from these two test are described below. For a full report refer to CLIN000102, Data Item A003 titled Test Report submitted in final form August 12, 2008.

### **7.3.2 Models Used for Test Data Analysis**

Two MathCAD models are used to analyze this and subsequent test results.

#### **7.3.2.1 Heat Loss Model**

This model primarily adjusts the Wyle data to serve as input to the Bleed Air Cooler Model described below. Each version is saved in a file “700F Heat Loss [5-12 data Case 2].mcd” where the numbers within the brackets change to reference the particular data set and assumptions.

This model primarily calculates two heat flows. A significant amount of the heat transferred from air to water goes through the baseplate rather than the heat pipes. In a full loaded bleed air cooler this path is negligible, but the test article has only 5 of the 39 rows populated with heat pipes so this path must be subtracted from the Wyle data to give a meaningful measure of heat pipe performance.

For the tests, the bleed air cooler shell was not insulated. Therefore, some of the heat from the hot air is simply lost to the ambient air, rather than being transferred to the cooling water. With reliable data, this would be the difference between the heat loss measured for the air and for the water, but in the early cases where the data violated the 2<sup>nd</sup> Law, it was necessary to calculate this heat loss to attempt to understand and de-bug the data.

The Heat Loss Model also performs certain calculations to generate inputs in a form that the BAC model can digest.

#### **7.3.2.2 Bleed Air Cooler Model**

This is the basic model that was used to design the Bleed Air Cooler. The primary purpose of the testing is to validate and refine the model. The geometry, flows, temperatures, etc are input from the data. The heat pipe resistance is an input to the model, not a calculated variable. The heat pipe resistance was varied so that the heat transport calculated by the model balances the power measured in the tests. Since the measured power in the early tests clearly violated the Second Law, the model was actually used to provide a clue as to the error source in the Wyle data.

### 7.3.3 Results from Testing of June 12, 2008

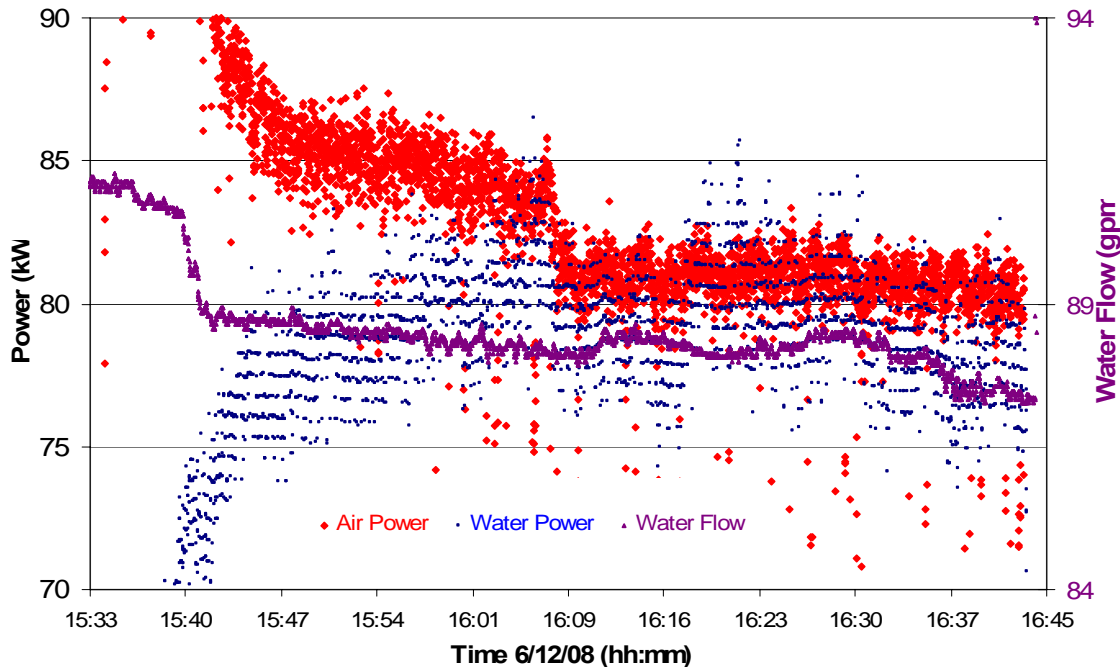
The water pump inlet was altered to ensure that it remained well submerged during all conditions. This eliminated the severe variations in the water flow in the previous test and provided the definitive data set. This test was conducted for only the 700°F inlet air condition, thus minimizing the effects of the significant thermal mass to affect the apparent heat transfer from air to water.

#### 7.3.3.1 Data Reference

The test data for 6/12/08 testing is contained in the file “Robin-069 with flow calc 083.xls”. This contains the model for the air flow correction as well as the Wyle air flow and power calculated using that model. The data from lines 3828-4067, which are the timelines from 16:33 to 16:36, were averaged to provide input for the heat pipe analysis. These averages became line 2.

The heat loss analysis is in MathCAD file “700F Heat Loss 6-12-data Case 1.mcd”. The HP-BAC model analyzing this data is in MathCAD file “700F BAC Model 6-12 data.mcd”. Since Wyle had confidence in the air and water data, only one case was run.

#### 7.3.3.2 Test Results



**Figure 28 Wyle Power and Flow Data from 6/12/08 Test**

Figure 28 shows the power and flow data as received from Wyle (BTU/minute was converted to kW). Note that the water flow is extremely steady with almost no spread in the data. With the steady flow, the scatter in the water power data has been reduced from about 20% on previous tests, to about 10%. This spread is due to scatter in the water temperature data.

While the scatter in the air power data appears random, the scatter in the water power data falls into distinct layers. The water temperatures, as recorded, also exhibit this layering. Although the data is recorded to five decimal places, the recorded values repeat discrete value multiple times. Table 6 shows 21 consecutive data points for water outlet temperature. The various colors show

repetitions of data points to five decimal places. This is clearly an artifact of the data collection system.

106.64747	106.47938	106.64747	106.64747	106.42335	106.47938	106.64747
106.59144	106.47938	106.7035	106.59144	106.59144	106.59144	106.75954
106.64747	106.75954	106.75954	106.75954	106.7035	106.81557	106.81557

### 7.3.3.3 Analysis

#### 7.3.3.3.1 Heat Loss Analysis

The Wyle data was used directly. The heat loss model calculated that 12.5 kW was being transferred to the water thru the tube sheet (plate). Since the Wyle data indicated that the water had absorbed 78.2 kW, this meant that the heat pipes were transferring 65.7 kW.

The heat loss program calculated that 7.86 kW was being lost through the uninsulated shell of the BAC. This should account for the difference between the heat loss by the air (80.5 kW) and the heat gained by the water (78.2 kW). The measured difference of 2.3 kW is less than 1/3 of the calculated 7.86 kW. For the 6/10 test the measured difference was 81% of calculated.

#### 7.3.3.3.2 HP-BAC Model Analysis

The HP-BAC could not balance the 65.7 kW that the heat pipes were apparently transporting based on the Wyle data. If a heat pipe resistance of 0.001 °C/watt was assumed in the model, the calculated heat pipe power was 62 kW compared to the 65.7 kW test value. At this resistance the model predicts heat pipe wall temperatures of 97.0 and 93.1°C which are much higher than the 84.5 and 88.3°C measured during the test. When the model was run at a reasonable resistance of 0.020 °C/watt, it predicted heat pipe wall temperatures of 89.8 and 86.9°C which compare well with the measured values. At this resistance the model calculated heat pipe power of 54.9 kW which is far short of the 65.7 kW indicated by the Wyle data.

### 7.3.4 Heat Pipe “D” Testing, Nov.-Dec. 2007

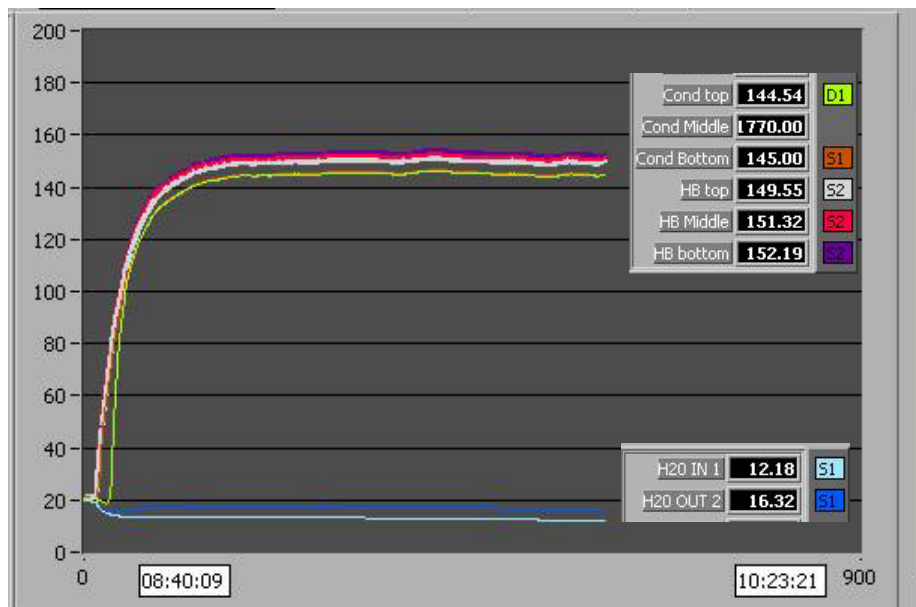
All of the heat pipes used in the engineering test unit were tested at Thermacore, as were a number of other heat pipes which were built to assure that the new design and processing resulted in a pipe that exceeded the original requirement. Of all these heat pipes, Heat Pipe “D” was tested in a configuration that is closest to the actual operating conditions.

The letter “D” is a serial number engraved on the evaporator end cap. HP “D” was one of five heat pipes made to examine the transition from bare thermosyphons to fully wicked pipes. Heat Pipe “C” used a felt wick and exhibited gassing. Heat Pipe “E” was the burst test pipe.

#### 7.3.4.1 Bare Pipe Test, Nov 15, 2007

Before the fins were brazed to the pipe, but after the wick was sintered into the bare tubing, the heat pipe was tested to establish a baseline performance. The condenser side was cooled by circulating water thru copper tubing that was coiled around the top of the heat pipe. The evaporator was heated within a heater block clamped around the pipe. The heater block had spring loaded thermocouples through the block at three locations to measure the heated surface directly.

Figure 29 is a screenshot of the test results as displayed in LabView at 10:23 a.m. These same thermocouple readings were entered in the lab notebook, which also documented the water flow



**Figure 29 LabView Data from Bare Pipe Test on 11/15/07**

rate at 1500 cc/min. At this flowrate, each 1°C rise in the water temperature equals 105 watts of heat absorbed by the water. The pipe had been run for about an hour on the previous evening with roughly similar performance. The water rose 4.08°C which indicates power transport of 438 watts. The average condenser temperature was 145.0°C, the average evaporator temperature was 151.02°C for a heat pipe delta-T of 6.29°C. This yields a measured conductance of 69.1 W/°C or a resistance of 0.0145 °C/watt.

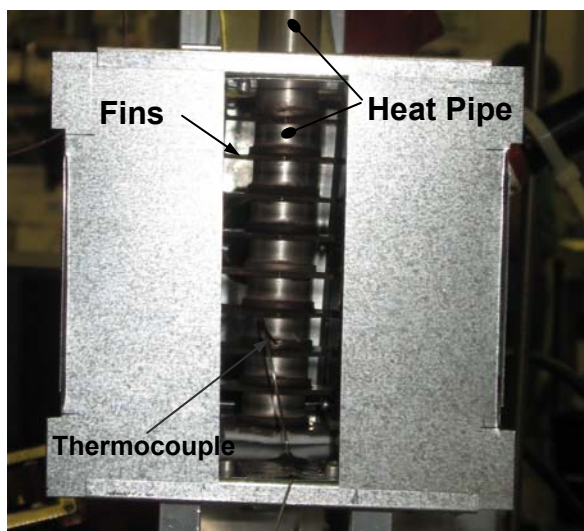
### 7.3.4.2 Heat Pipe “D” Test of 12/5/07

For this test, the heat pipe was fully processed with the fill tube pinched and welded off. The condenser end was sealed in a canister where it was directly in the flowing water. The evaporator side was heated with hot air. This was the lab test most representative of the conditions in an operating HP-BAC.

#### 7.3.4.2.1 Test Equipment and Set Up

Figure 9 in Section 5 shows the overall test set up. Three industrial heat guns supply hot air into a plenum which channels the hot air into an appropriate flow channel duct for a single heat pipe. Figure 30 shows the heat pipe from the exhaust end of test ducts. The flow cross section of the duct is 1.625”x 4.5625”. Doors on the end can be used to throttle the flow, and are shown partially closed in this view.

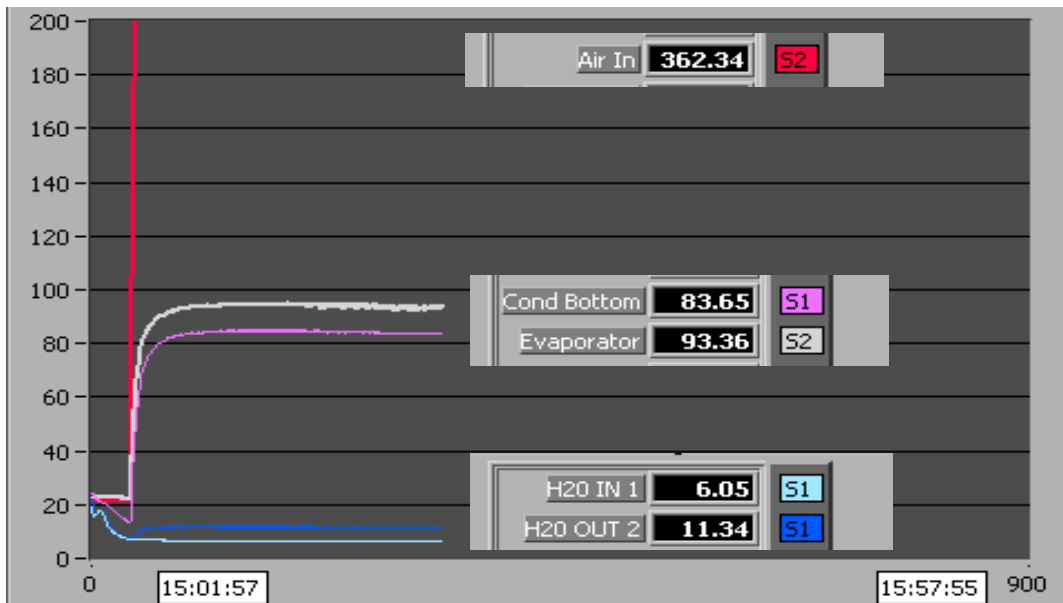
This arrangement does achieve the BAC operating air temperature, but, without compressors, it cannot begin to match the operating mass flow or volume flow. The heat guns produced a measured velocity of 490 to



**Figure 30 Duct Outlet View**

580 feet/min with two heat guns running. A value of 550 ft/min was taken as the average velocity through the duct. The measured velocity results in a volume flow of 28.3 cfm per heat pipe and a mass flow of 56.2 lb/hr per heat pipe. The actual operating volume flow is 4.6 times the test flow, and the operating mass flow is 40.4 times the test flow.

### 3.8.2.2 Test Results of 12/5/07



**Figure 31 LabView Data from Heat Pipe “D” Test on 12/5/07**

Figure 31 is a composite screenshot of the test data as displayed in LabView at 3:57 pm on December 5, 2007. This was the last data set recorded in the lab book and was used as the basis of analysis. The lab book also documented the coolant water flow rate of 1500 cc/minute. At this flowrate, each 1°C rise in the water temperature equals 105 watts of heat absorbed by the water so the temperature difference between water inlet and outlet of (5.29°C) indicates power transport of 555.5 watts. The temperature difference between evaporator and condenser (9.71°C) yields a heat pipe conductance of 57.2 W/°C which is a heat pipe resistance of 0.0175 °C/watt. To put this in perspective, the HP-BAC aboard the Ramage was designed assuming a heat pipe resistance of 0.07°C/watt and the heat pipes in the shipboard test averaged only 0.205°C/watt.

## 7.4. Analysis and Conclusions

Data was analyzed as it was obtained, but most of the Wyle tests clearly had erroneous data. The 6/10 test was the first Wyle test that was not violating the Second Law, and the June 12 test data is the official reference for the testing. All analysis in this section refers to the 6/12/08 test data.

The heat pipe “D” testing was performed back in December 2007. This was not done to quantify heat pipe performance but to evaluate the effects of welding and brazing processes on the heat pipe. When the official Wyle test data combined with the HP-BAC Model gave unreasonable values for heat pipe performance, the Heat Pipe “D” test data was revisited to help clarify the results.

The various tests and the model are discussed above. This section examines them together to best evaluate all results and the plan for going forward. To facilitate cross-comparison, all data was reduced to thermal resistances. These are summarized in Table 7.



Table 7 Summary of Thermal Resistance Predictions and Results					
Test	LAB TEST BASELINE			Wyle Test Conditions	
Category	HP "D"	KLW	ALP	WYLE	KLW
Parameter	Test Results	MODEL	MODEL	AVERAGE	MODEL
$R_{\text{airside}} (^{\circ}\text{C/W})$	0.480	1.006	1.427	0.027	0.109
$R_{\text{H}_2\text{Oside}} (^{\circ}\text{C/W})$	0.140	0.189	0.174	0.018	0.022
$R_{\text{HP}} (^{\circ}\text{C/W})$	0.017	0.024	0.024	0.091	0.024
$R_{\text{total}} (^{\circ}\text{C/W})$	0.637	1.219	1.625	0.135	0.155

In this table and subsequent discussions:  $R_{\text{airside}}$  is the thermal resistance from the air to the heat pipe wall; it includes the air-to-fin heat transfer coefficient and the conduction losses in the air side fins.  $R_{\text{H}_2\text{Oside}}$  is the thermal resistance from the heat pipe wall to the water; it includes the heat transfer coefficient from water-to-fin and the conduction losses in the fin.  $R_{\text{HP}}$  is the overall stand-alone heat pipe thermal resistance including conduction losses through the heat pipe walls in the evaporator and condenser, as well as the evaporation and condensation heat transfer coefficients.

### 7.4.1 Discussion of Results from Lab Test Baseline

The test setup and results for Heat Pipe “D” are described in Section 7.3.4 above. This data was reexamined to give further insight into the Wyle test results. This test was conducted at the same air temperature, but at much lower air flow, so the power transported was about 20% that of the Wyle test.

The HP-BAC Model, which is referred to as the KLW Model in Table 9 and most discussion in

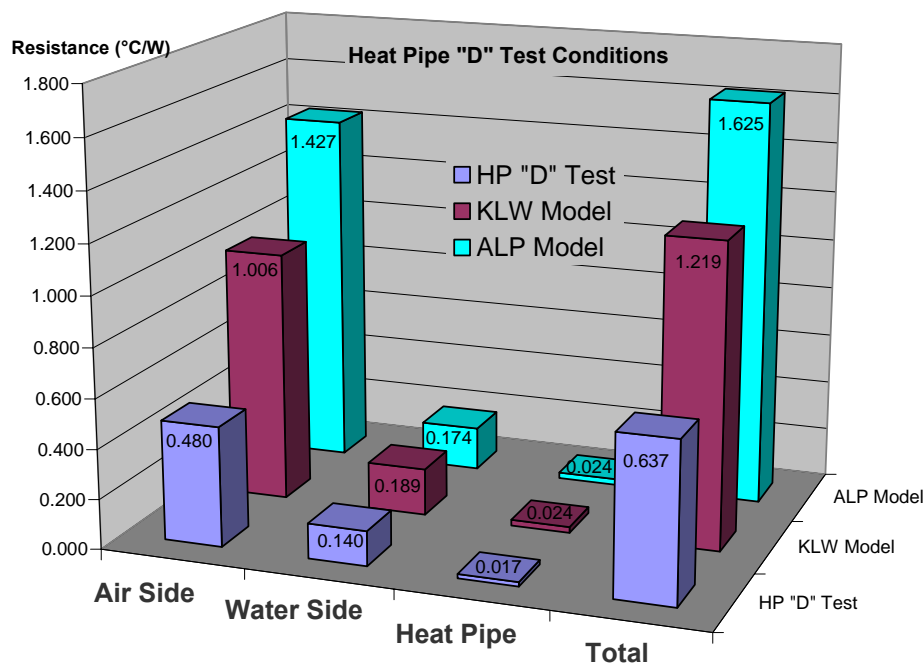


Figure 32 Thermal Resistance - Model Comparison with HP “D” Test Results

this section, models 39 rows of heat pipes in a staggered bank arrangement. A simplified, stand-alone, finned, heat pipe model was developed to more directly represent the HP “D” test conditions. This is referred to as the “ALP Model”. The resistances from the two models, and the as-calculated resistances from the Heat Pipe “D” test data, are presented in Table 9 and compared in Figure 32.

The heat pipe resistance of 0.017 °C/W shown in the HP “D” row was calculated directly from the measured temperatures. The value of 0.024 °C/W was an input to the models. The latter value was calculated independently (from first principles) and represents the minimum resistance that the heat pipe could have. Since this is considerably higher (about 40%) than the resistance measured in the testing, there is no question that the test data must be somewhat erroneous.

The most likely source of error on the heat pipe resistance would be measurement error on the evaporator and condenser temperatures. The thermocouples are trying to measure the wall temperature of the pipe while immersed in a stream of very hot gas or cold water. It is likely that the thermocouples are measuring (at least partly) the temperature of the fluid in which they are immersed rather than solely the temperature at the heat pipe wall. However, such errors would result in the heat pipe resistance being anomalously high rather than anomalously low. An error in the thermal power transport would produce anomalously low heat pipe resistance, but the calorimetry is less likely to be in significant error than the wall temperature readings. The flow meter was manually calibrated

Both models are conservative in that they predict higher thermal resistance than was observed in the testing.

### 7.4.2 Discussion of Results from Wyle Test Conditions

The tests conducted at Wyle Labs on June 12, 2008 represent the official test results of the Wyle test campaign and are described in Section 3.7 above. These results, expressed as thermal

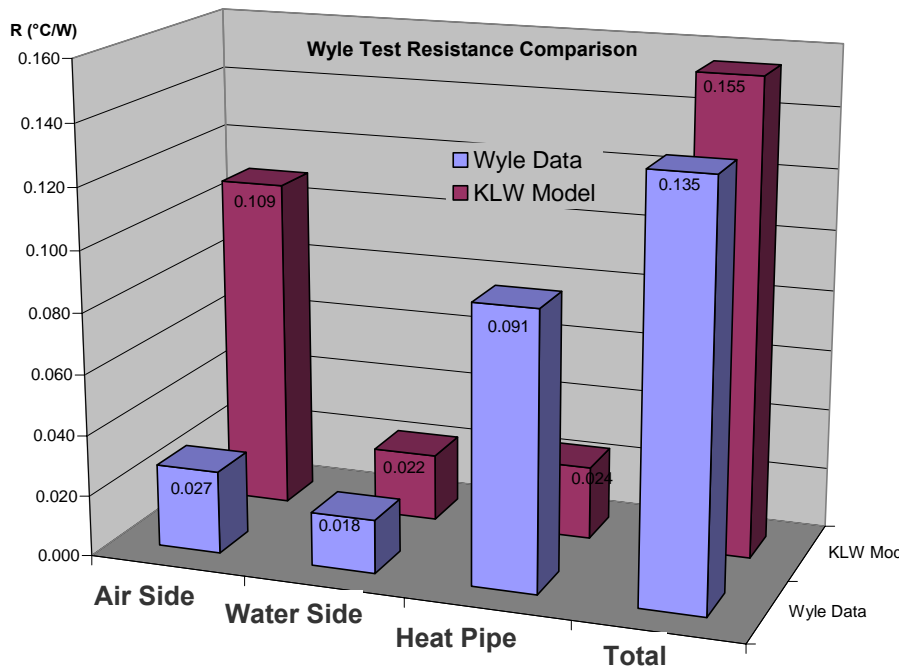


Figure 33 Thermal Resistance - Model Comparison with Wyle Test Results

resistances, are compared with the corresponding values calculated in the HP-BAC model (KLW Model) in Figure 33.

The overall results agree rather well; the model is somewhat conservative compared with the test results. The major variance between the model and the test data is the air side resistance. This is accounted for by the variance between the predicted heat pipe wall temperature and the measured heat pipe wall temperature on the air side. The data in Table 8 clearly shows this variation.

Table 8 Air-Side Data				
INLET AIR	FIRST ROW	LAST ROW		OUTLET AIR
393.5°C (740°F)	334°C	289°C	Test	337.6°C (641°F)
	136°C	128°C	Model	

The thermocouples are attempting to measure the temperature of the heat pipe wall while immersed in a turbulent flow of extremely hot air. From the data in Table 10, it should be clear that the thermocouples are being dominated by the air temperature rather than the heat pipe wall temperatures. (The other end of the heat pipe is immersed in water at 38°C, and both model and test data show a water side wall temperature near 87°C.) These erroneous high temperature readings result in the very high heat pipe resistance, as well as the unreasonably low air side resistance, measured in the testing. In future tests, intrinsic thermocouple junctions will be used to minimize this problem.

The large variation in air-side and heat pipe thermal resistance shown in Figure 33 is clearly due to the erroneous temperature measurement. The total heat transport, as measured and as calculated, agree to within 15%, which is within the expected accuracy of the correlations used in the model. The large error in air side temperature measurement precludes an accurate calibration of the heat pipe resistance under actual operating conditions.

## 7.5. Interpretation of Results

### 7.5.1 Overall Conclusions/Interpretations

The following conclusions/interpretations can be safely made from the test data and analysis:

1. The HP-BAC model is of the correct form and accurately predicts the relative performance of  $R_{\text{airside}}$ ,  $R_{\text{H}_2\text{Oside}}$  and  $R_{\text{HP}}$ . This is most clearly seen in Figure 32.
2. There exists some doubt about the accuracy of the Heat Pipe “D” test results since the measured resistance is less than the thru-the-wall conduction resistance of the heat pipe itself.
3. The measured values of the air-side heat pipe wall temperature in the June 12 test data are very high and are concluded to be dominated by the air temperature rather than the wall temperature.  $R_{\text{airside}}$  should be higher, and  $R_{\text{HP}}$  should be lower so these resistances are of the same relative relationship as the HP-BAC (KLW) model data in Figure 33.
4. The overall resistance predicted by the model is 15% higher than that measured in the tests. While this is within the expectations of a model based on correlations rather than first principles, the error in the air-side temperature measurements precludes using the test results as a direct calibration of the model.

### 7.5.2 Project Engineer's Conclusions/Interpretations/Conjecture

The project engineer has two conclusions which are based on a feel for the data and the hardware:

1. The Wyle data for water flow and/or water power is high. The correct flow/power is somewhat lower. This conclusion (conjecture) is based on the following indications:
  - a. Most of the tests run at Wyle had the water removing more energy than the air was supplying. These correction involved moving the water flow meter so it was not picking up cavitation on the downstream of the throttling valve, and moving the water inlet so it was not sucking air at the inlet. Both errors resulted in overstating the water flow rate.
  - b. The water power data is layered (see Figure 28) which indicates some smoothing function is being applied to the data collection which has not been identified.
  - c. The heat that is being lost to ambient air from the uninsulated Bleed Air Cooler, while not impossibly low, is much less than would be expected for the test conditions.

Reducing the water flow/power value would raise the overall resistance and reduce the variance with the model.

2. The heat pipe resistance value used in the models is still too low. The present value is the absolute minimum of what it could be.

One statement: Although the project engineer expresses some doubts about the official test data, it is certainly worthy of note that these doubts are because the data say the HP-BAC is performing too well and not because the data say it is performing below expectations.

### 7.6 Actions Going Forward

The Heat Pipe “D” testing will be repeated with the explicit purpose of accurately measuring the heat pipe thermal resistance. This will employ intrinsic thermocouples and closely calibrated calorimetry.

The validated heat pipe resistance will then be used to reapportion the resistances in the Wyle test data. This should result in the Wyle data bars assuming very nearly the same shape as the KLV model bars in Figure 33. This still leaves about a 15% variance between the total resistance for the two cases. With a somewhat higher value for the heat pipe resistance in the HP-BAC model, its overall resistance will increase, somewhat raising the total variance.

The model is based on heat transfer correlations relating to staggered tube banks. A 15% variance is within the expected tolerance and it would be straightforward to use the Wyle data to recalibrate the model. As stated in 7.5.2 above, the Project Engineer doubts the Wyle data relating to water flow, and the design going forward will not recalibrate by the full 15%. This will allow some margin for the more varied flow conditions that will be encountered with the extended, multi-length heat pipes in the pre-production unit.

**Appendix D**

**IMPROVED FIN ATTACHMENT AND FIN COUNT**

# IMPROVED FIN ATTACHMENT AND FIN COUNT

*A report that constitutes*

**CLIN 000102, part of Data Item A002**

**Contract N65540-06-C-0022**

**October 10, 2007**



**Heat Pipe #2 with Cast Fins**

**Showing excellent braze**



**Thermacore International, Inc.**  
A subsidiary of Modine Manufacturing Company



## Executive Summary

Cast fins were obtained to improve the thermal resistance associated with the fin/heat pipe interface in the original heat pipe bleed air cooler (HPBAC).

Two heat pipes were fabricated using the new fin design. HP#1 used new design fins that were slightly out of spec. HP#2 used a later batch of fins that were well within all specifications. The later fins resulted in much better brazes.

Conductance tests were performed to measure the thermal resistance from the fins to the heat pipe wall. The measured delta-Ts were:

Heat Pipe #1	9.87 °C
Heat Pipe #2	8.32 °C
Heat Pipe #195	62.05 °C (This was from the original HPBAC)

### Conclusions

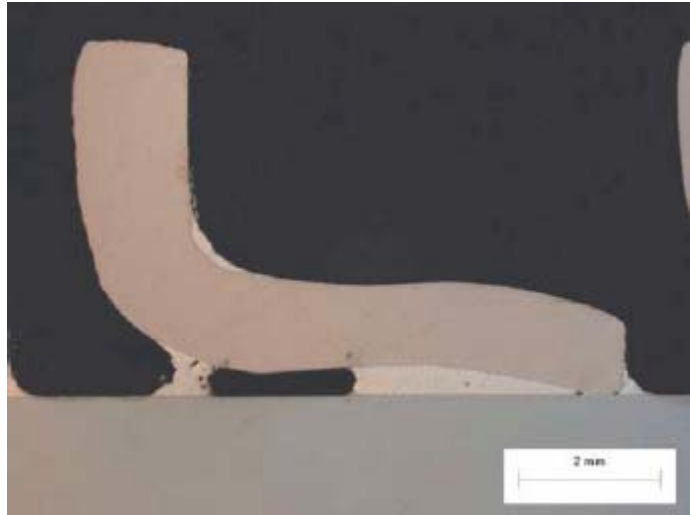
The new fin design produced a factor of six improvement in the conductance between the fin and the heat pipe.

The conductance difference between HP#1 and HP#2 was 15.5% which confirms and justifies the need for the tight fin dimensional tolerances

## Background

One of the shortcomings recognized in the prototype BAC, was the brazing of the fins to the heat pipes. The original fins were formed, but copper nickel does not draw very well. Figure 1 shows the shape of the fin collar and its impact on fit and braze.

The direct contact between the collar and the heat pipe is limited to a very thin line (at the right in Figure 1). About two-thirds of the available contact length is occupied by thick braze material, and about one-third is simply void. The braze material is a poor conductor compared to the base copper-nickel, and the void is an insulator. The result is a very high thermal resistance between the fin and the heat pipe. This was identified as an area for improvement and was specifically addressed as Item 3.4.4 of the present contract.



**Figure 1 Fin Braze Detail**  
from EWI Welding Report (N00014-02-C-0106)

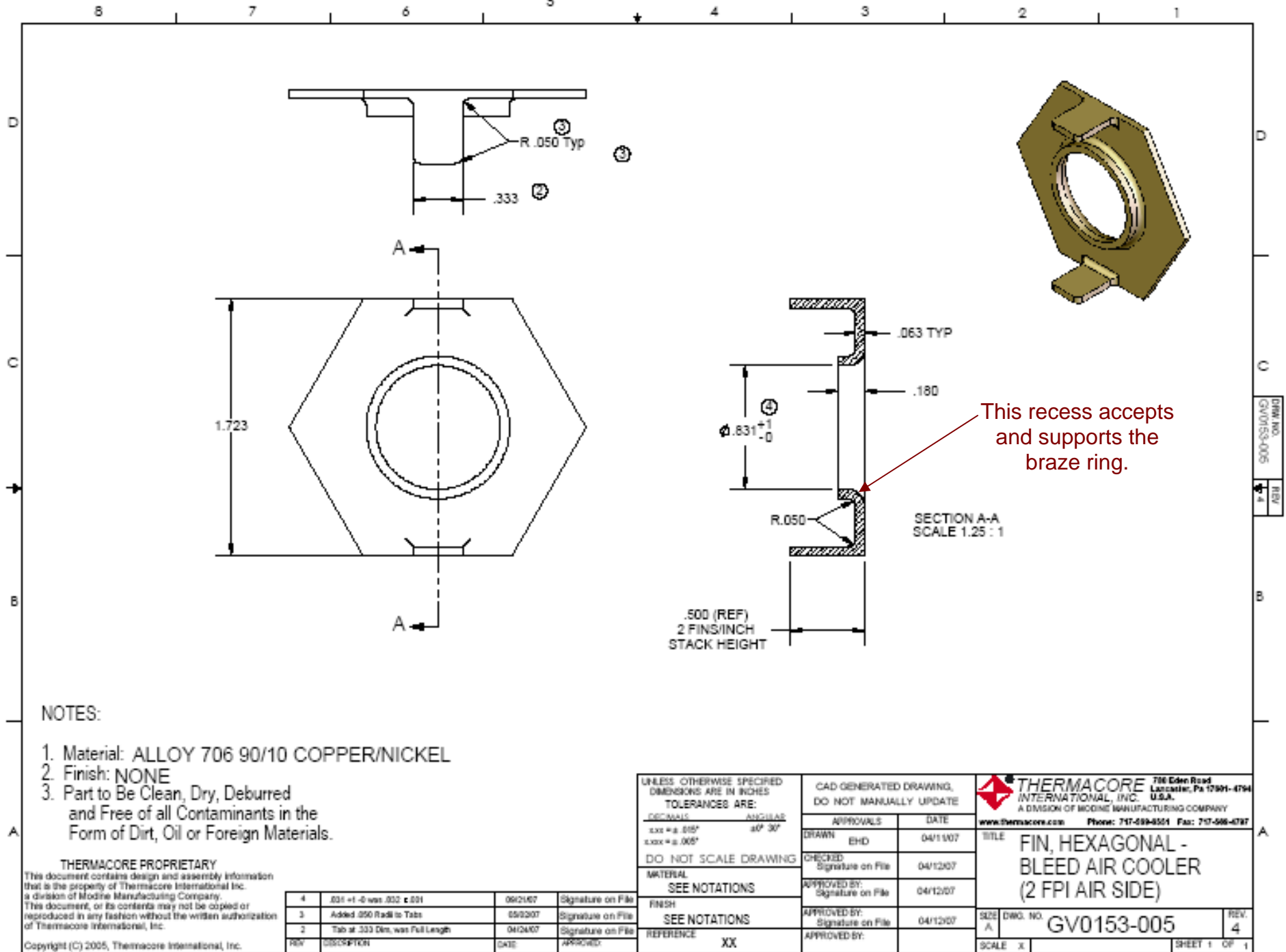
## New Fin Design and Fabrication

Casting the fins would eliminate the forming problems and some cracking issues, but it was ultimately determined that only machining of the cast fins would provide an interface that would allow a truly effective braze joint. Vforge of Lakewood CO developed a casting technique and supplied the fins used to make test article heat pipes. Vforge was contracted by Advanced Technology Institute (ATI) of Charleston, SC to advance the development of semi-solid-material (SSM) casting technology in copper materials. ATI and Vforge have been working with NSWC and Thermacore to improve fin fit and performance. The contributions of Vforge and ATI to this effort are supported under the Copper-Based Casting Technology program, Cooperative Agreement W911NF-04-2-0008 between The Advanced Technology Institute (ATI and the U.S. Army Research Laboratory (ARL).

The design of the air side inlet fin which was used for these heat pipes is shown in Figure 2 which is drawing GV0153-005. Three features of this design should be noted. One is the incorporation of tabs on the side to permit the stacking of fins to provide the 2 fins/inch spacing required for the air inlet section. The second feature is the radius on the top (non tab side) which supports a ring of braze material. The third feature is the tolerancing on the ID of the fin. Combined with the tolerancing on the heat pipe shell, this sets the maximum gap that must be bridged by the braze. This ensures that there will be no voids between the fin and the heat pipe, and also minimized the thickness of the relatively poor conducting braze material.

The first set of fins received were out of spec. In order to proceed with fabrication, the heat pipe body was machined slightly smaller than specified so that the fins would fit over it. These first fins were slightly out of round, so that the maximum gap between fin and heat pipe exceeded





NOTES:

1. Material: ALLOY 706 90/10 COPPER/NICKEL
2. Finish: NONE
3. Part to Be Clean, Dry, Deburred and Free of all Contaminants in the Form of Dirt, Oil or Foreign Materials.

**THERMACORE PROPRIETARY**

This document contains design and assembly information that is the property of Thermacore International, Inc. a division of Modine Manufacturing Company. This document, or its contents may not be copied or reproduced in any fashion without the written authorization of Thermacore International, Inc.

Copyright (C) 2005, Thermacore International, Inc.

REV	DESCRIPTION	DATE	APPROVED
4	.001 +/- 0 was .002 +/- 0.01	09/21/07	Signature on File
3	Added .050 Radii to Tabs	05/22/07	Signature on File
2	Tab at .333 Dim. was Full Length	04/24/07	Signature on File

UNLESS OTHERWISE SPECIFIED DIMENSIONS ARE IN INCHES TOLERANCES ARE: DECIMALS      ANGULAR .xxx = ± .015"      ±0° 30" .xxx = ± .005"	CAD GENERATED DRAWING, DO NOT MANUALLY UPDATE		706 Eden Road Lancaster, Pa 17601-4794 U.S.A. A DIVISION OF MODINE MANUFACTURING COMPANY www.thermacore.com    Phone: 717-599-4551    Fax: 717-566-4787	
	APPROVALS DRAWN    EHD	DATE 04/11/07		TITLE FIN, HEXAGONAL - BLEED AIR COOLER (2 FPI AIR SIDE)
	CHECKED Signature on File	DATE 04/12/07		
	MATERIAL SEE NOTATIONS	APPROVED BY: Signature on File		DATE 04/12/07
FINISH SEE NOTATIONS	APPROVED BY: Signature on File	DATE 04/12/07	SIZE A	
REFERENCE XX	APPROVED BY:	DATE:	DWG. NO. GV0153-005	
SCALE    X			REV. 4	

Figure 2 Design for Air Side Inlet Fin

specification. Since the gap was still sufficiently small that capillary pressure would constrain the braze so it wouldn't drain from the joint, it would provide a good braze, and assembly proceeded with the fins on hand. The issue was discussed with Vforge. The out of tolerance was not related to the SSM casting process, but was a misunderstanding on their machining step, and was promptly resolved. The second set of fins were well within specifications, and produced beautiful brazes.

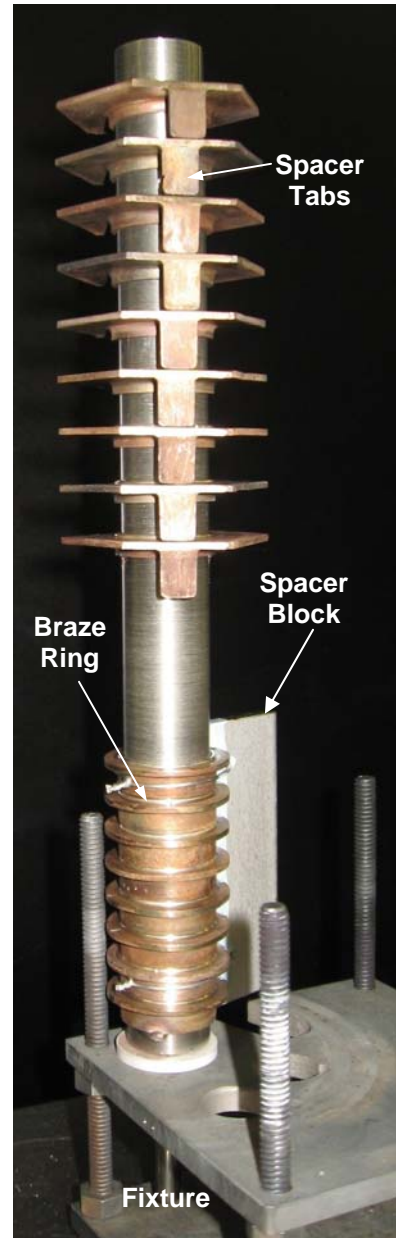
## Heat Pipe #1

The proof of the fin design required the fabrication of test heat pipes. This would verify fit, brazing effectiveness and performance, and would reveal any unanticipated assembly or processing problems. Figure 3 shows the heat pipe, with fins positioned, ready to be put in the brazing furnace. The first air-side fin is tack welded in position and the remaining air fins are stacked using the tabs cast into the fins. Note that in an actual bleed air cooler the lower tabs would rest on the mid plate and the tack weld would not be required. The bottom water-side fin is also tack welded, but the upper fins are spaced using a spacer block. Rings of braze wire fit nicely in the recess designed into the fins to receive the rings. When the ring melts, capillary effects pull the molten braze into the gap between the fin and the pipe. The braze rings do not touch the fin above them, so the braze material per fin is fixed. Material that does not fit into the gap is left in a puddle in the recess, and in a meniscus at the bottom of the fin. The braze results are discussed below.

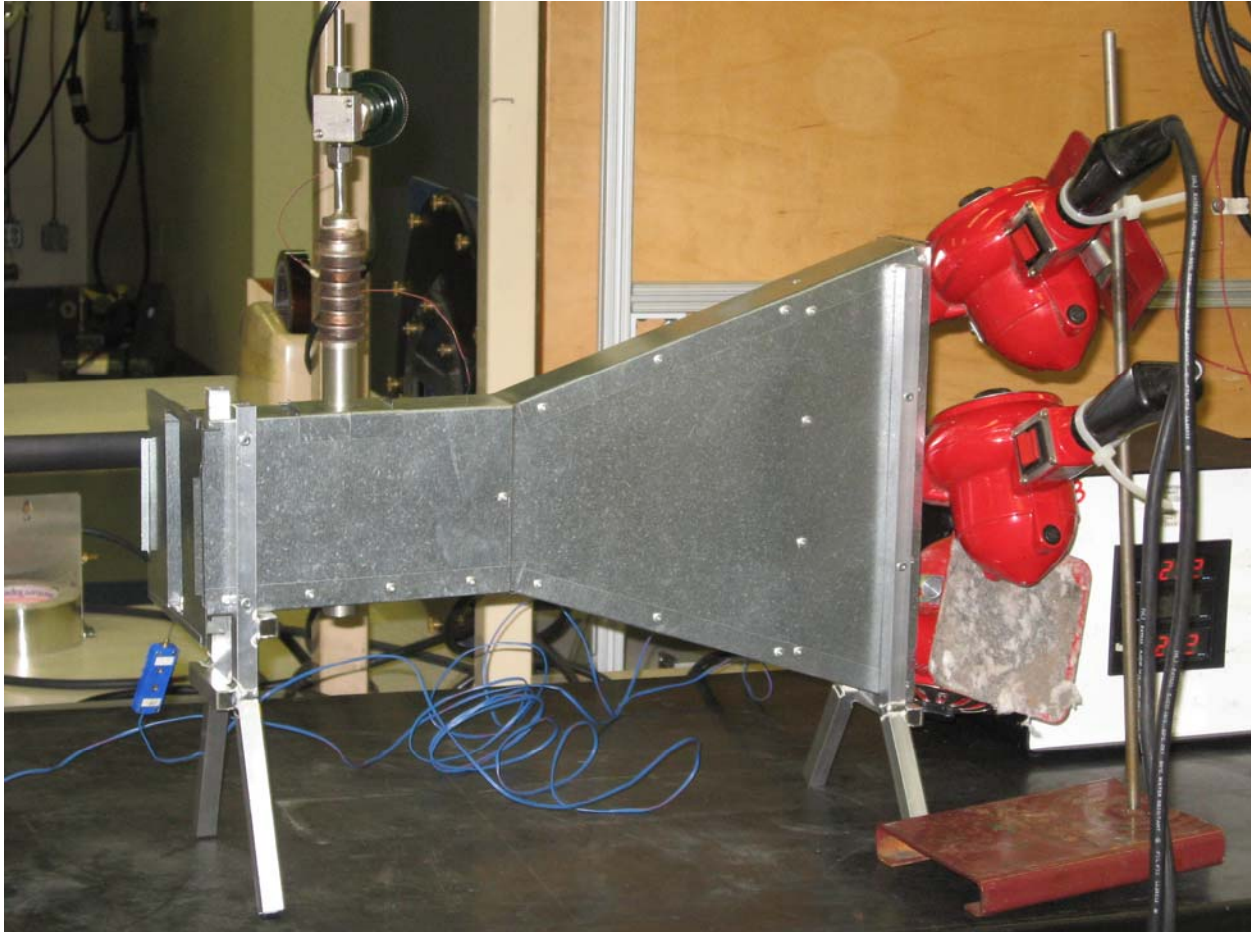
Figure 4 shows the heat pipe after brazing as installed in the test duct prior to charging and processing. It was processed in this duct using heated air on the evaporator side and cool air on the condenser side.

## Heat Pipe #2

The fabrication of heat pipe #2 was delayed so that the second batch of fins could be used. These fins were well within specification and eased assembly. The braze results are discussed below. Figure 5 shows Heat pipe #2 after brazing and before processing. This used water flowing through a coil of copper tubing to cool the condenser during process. The water cooling arrangement used for testing the heat pipes, shown in Figures 10 could not be used until the valve was removed and the fill tube pinched off.



**Figure 3 HP#1 Ready to Braze**



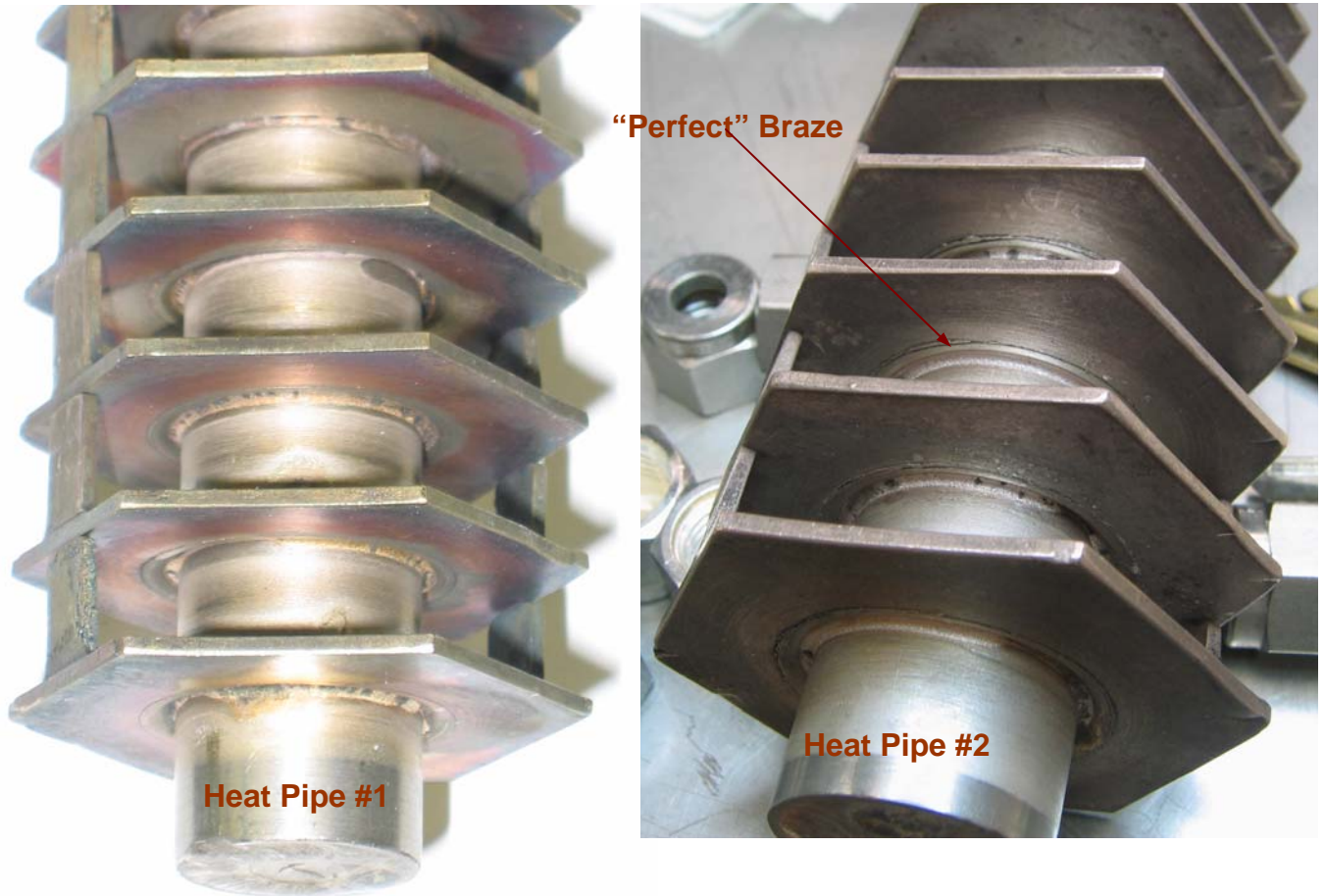
**Figure 4 HP#1 in Test Duct**



**Figure 5 HP#2 Showing Water Cooling Coil**

## BRAZE COMPARISON

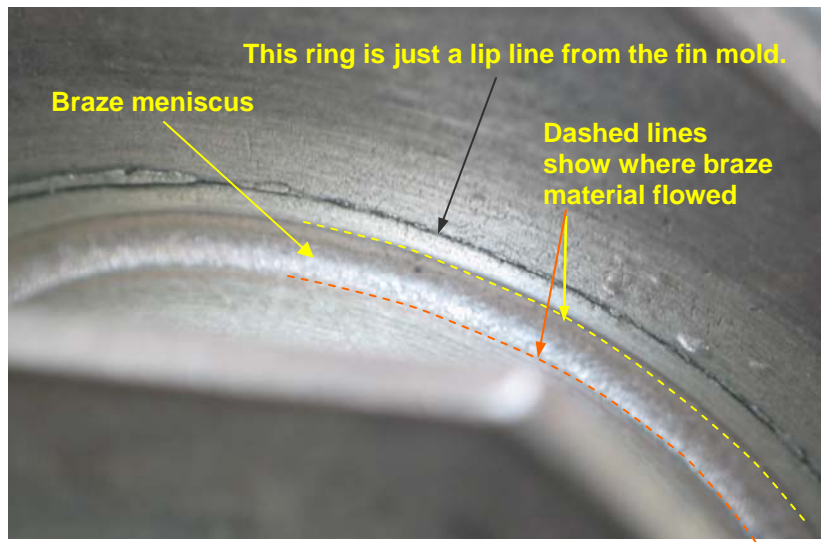
Figure 6 shows the fin braze results for the two heat pipes. Compare these brazes with the braze in Figure 1 to put the improvements in perspective.



**Figure 6 Fin Braze Images**

Heat Pipe #1 yielded very good visual results; heat pipe #2 was slightly better. One consistent difference that can be seen by studying the images is that the braze fillets are slightly higher (i.e. closer to the plane of the fin) for heat pipe #2. Since each braze rings contains the same amount of material, this indicates that there were less gaps to fill on heat pipe #2, and provides visual confirmation of the better fit of the fins.

Figure 7 gives a magnified close up view of the resulting braze. This is simply a beautiful braze.



**Figure 7 Close-up View of Braze**

## Fin to Heat Pipe Conductivity Test

Figure 8 shows the simple heater block used to evaluate the thermal connection of the fins and heat pipe. It encloses two 50 watt cartridge heaters. The test data was taken at a total power of 55 watts which corresponds to about 20% of the per-fin power when the BAC is at its design power of 425 kW.

The heater block clamps to the edge of the fin and has a slight lip that rests on a thin section of the top. Figure 9 shows a cross section of the heater block to illustrate how it is mounted and how the heat enters the fin. Figure 9 also shows the location of the two thermocouples. One is on the upper surface of the fin and is a conservative representation of the fin temperature.

The second t/c is mounted on the heat pipe wall just below the fin. Both are slightly embedded in shallow holes in the surfaces they are monitoring.

The temperature difference between these two points is primarily caused by the resistance of the coupling between the fin and the heat pipe. This delta-T is a quantitative measure of the thermal connection between fin and heat pipe.

### Conduction Test for Heat Pipe #1

The power was raised to an indicated 102 watts and the temperature at the fin rose to 200°C at which point the power was reduced to an indicated 54 watts. After 15 minutes the temperature had stabilized around 168° for the fin. Six data sets were taken over the next 45 minutes with random variations between them. The lowest delta-T recorded was 9.4 °C and the highest delta-T was 10.4 °C. The average was 9.87 °C.

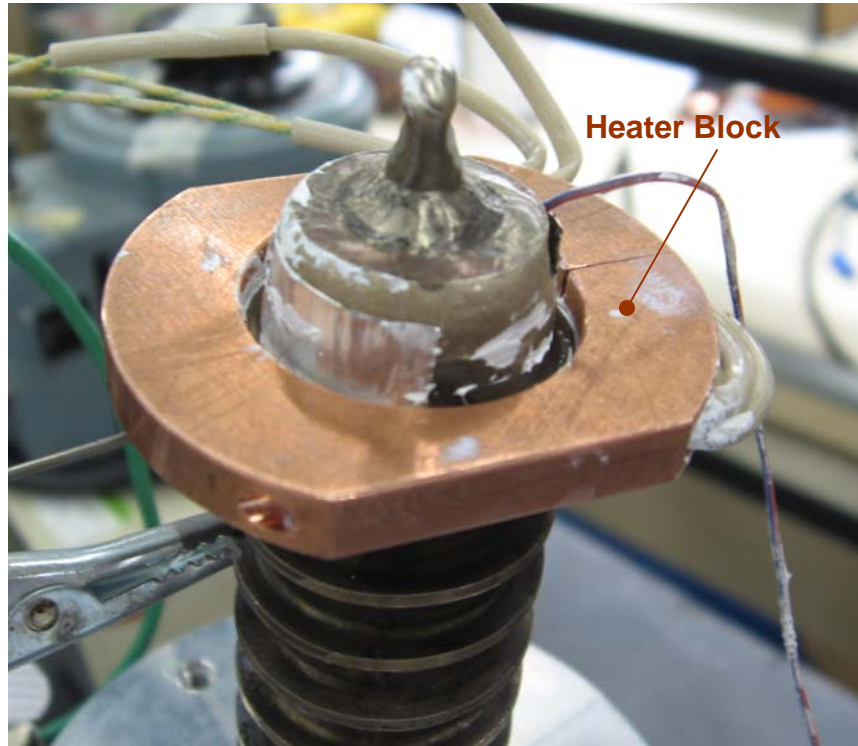


Figure 8 Fin Conductivity Test Setup

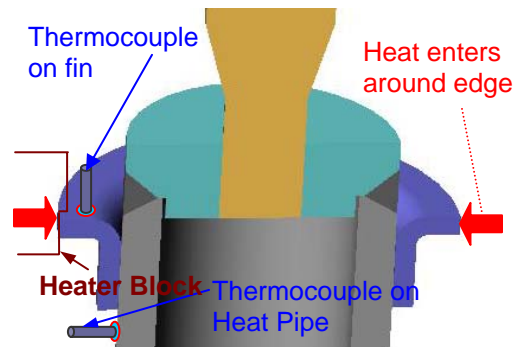


Figure 9 T/C's and Heat Input

## ***Conduction Test for Heat Pipe #195 from the Unsuccessful Prototype BAC***

The test was repeated on a heat pipe from the existing bleed air cooler to quantify the improvement from the new fins and brazing. Heat pipe #195 was tested because it was the most accessible, located at the corner of the heat pipe array. The fin and heat pipe were cleaned of corrosion and crud. The same preparation as for HP #1 was repeated, including drilling shallow holes (t/c wells) to fix the thermocouples and make sure their junction was inside the surface it was measuring. Thermal grease was used around the heater block and in the t/c wells. The same equipment from the HP#1 test was reused.

To warm things up, the power was initially set to an indicated 100 watts. The fin temperature rapidly shot up to 250°C so power was lowered to an indicated 55 W. Temperature lowered then crept back up. As expected for a conduction measurement, the delta-T remained reasonably constant as the fin temperature rose from 248.0°C to 259.7° over the next quarter hour. The average delta-T over this period was 62.05 °C.

## ***Conduction Test for Heat Pipe #2***

The test was repeated on Heat Pipe #2 using the same equipment. At this time HP#2 was not charged so it was not working as a heat pipe. The power was initially set to 100 watts and when the fin temperature passed 200°C it was reduced to an indicated 55 Watts.

The fin temperature settled in the 228 to 230°C range. Five readings were taken that varied from 8.2 to 8.4 °C and averaged 8.32 °C.

It should be noted that HP#2 had 1.5 °C less delta-T than HP#1, or a 15.7% reduction. While the differences visible in Figure 6, may not be that apparent much less dramatic, a 15% reduction in delta-T is very significant.

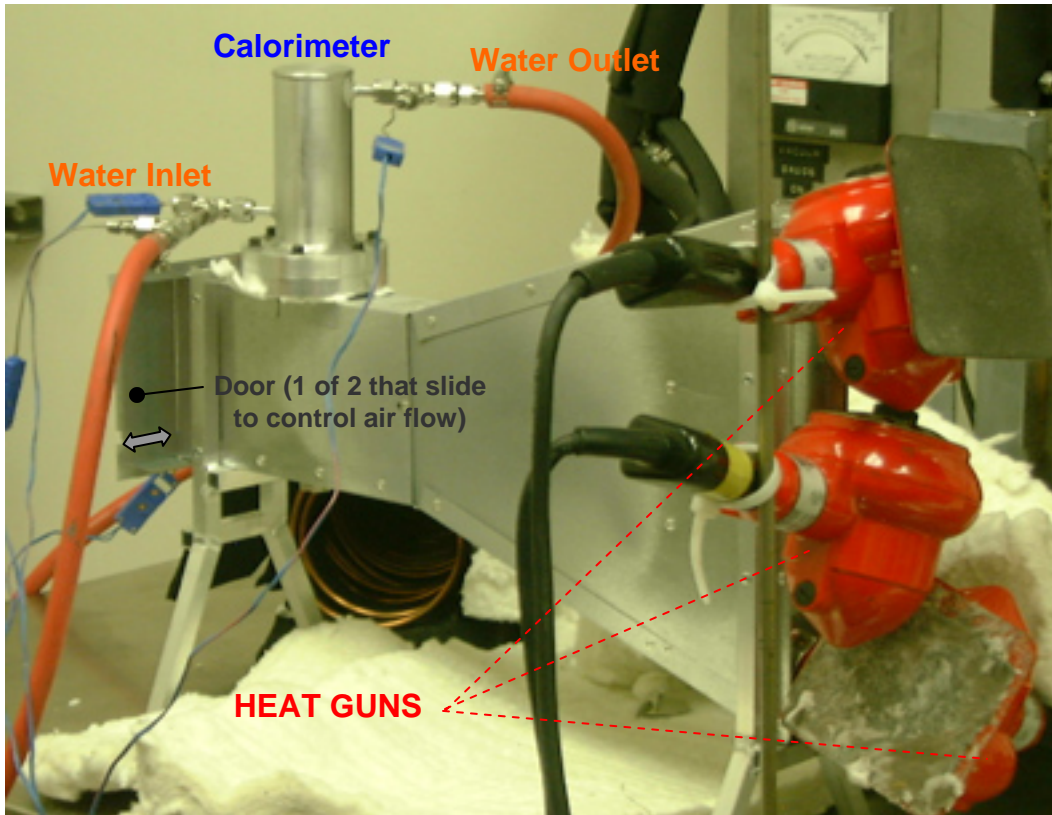
## ***Conclusions***

The new fin design reduced the thermal resistance from the fin to the heat pipe by a factor of five. This corresponded to a 50 °C reduction in delta-T at 20% of BAC design power. The improvement brought about by the SSM cast fins and the tighter tolerances and better brazes they enabled, exceeded the expectations of most parties involved. These measurement would indicate that the original fins played a larger part in the shortcomings of the prototype BAC than had been appreciated in the post analysis.

The conduction difference between HP#1 and HP #2 was 15.5%. HP #1 had slightly out of spec fin dimensions while HP#2 fins were well within specification. The 15.5% measured difference in conductance verifies the effectiveness of the specification tolerances.

## Heat Pipe Testing

Figure 10 shows the test setup prior to installation of insulation. Figure 4 provided a different view of the ducting and showed the heat pipe extending out the top. In Figure 10 the heat pipe condenser has been enclosed in a water jacket instrumented to serve as a calorimeter. The water flow, and the inlet and outlet temperatures, measure the power actually transmitted by the heat pipe.



**Figure 10 Heat Pipe Test Setup**

The design of this test setup first considered airflow. The shipboard tests were up to 1750 scfm which is approximately 10 cfm per heat pipe. The heat guns can deliver almost 1750 watts each and deliver up to 700°C temperatures. Their flow rate was measured using a flowmeter and found to be 10.5 cfm through the flowmeter. Three heat guns would therefore provide more than sufficient airflow that could be throttled by the sliding doors on the outlet of the duct.

### **Heat Pipe Test Results**

These heat pipes were built to test the effectiveness of fin design and brazing. They were built of thick walled tube (class 3300, 70/30 Cu/Ni tubing as defined in MIL-T-16420) because it was available in a timely manner.

Heat pipe #1 was fully processed and tested in the test stand shown in Figure 10. The best value of conductance was 7.5 W/°C which corresponds to a thermal resistance of 0.133 °C/watt.

Heat Pipe #2 was evaluated during processing when it was cooled by a coil (see Fig 5), rather than the calorimeter shown in Figure 10. The best conductance value for #2 was 11.7 W/°C which corresponds to 0.085 °C/watt.

## **Appendix E**

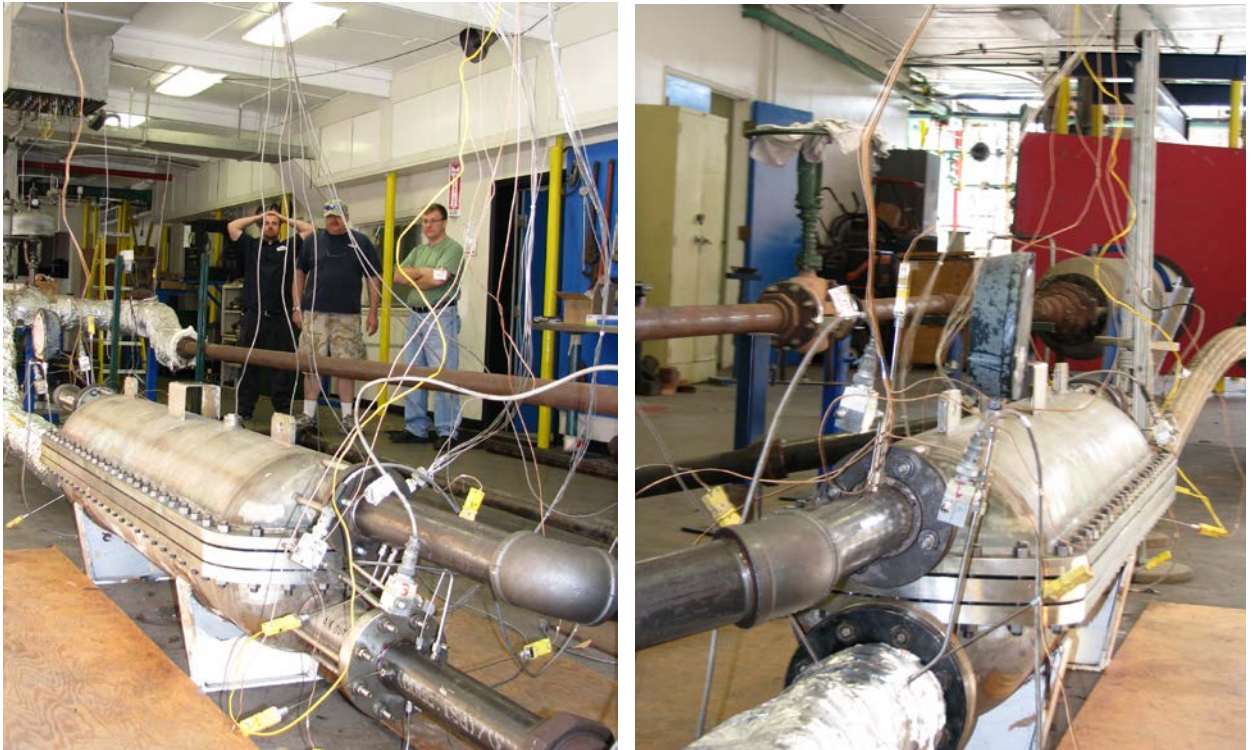
### **PRODUCTION COST ANALYSIS**



## PRODUCTION COST ANALYSIS

A report that constitutes  
**CLIN000102 Data Item 006**  
of  
**Contract N65540-06-C-0022**

**March 31, 2008**  
(Final version June 2, 2008)



**Bleed Air Cooler Engineering Unit on test at Wyle Laboratories, April 17, 2008**



Thermacore, Inc.

## Table Of Contents

1. The BASE Production Cost Estimate .....	2
1.1 Components of Cost.....	2
1.1.1 Pressure Shell.....	2
1.1.2 Internal Materials and Parts .....	2
1.1.3 Assembly and Processing .....	2
1.2 Cost Comparisons .....	2
1.2.1 Comparison with Production Cost Estimate of 2005.....	2
1.2.2 Cost Comparison with the Masker Cooler.....	2
1.3 Estimated Production Cost with heat pipes processed Out-of-Plate.....	4
1.4 Estimated Production Cost for Stand-Alone Heat Pipes.....	5
2. Technical Issues and Changes .....	5
2. Technical Issues and Changes .....	6
2.1 Background.....	6
2.2 Change to Cast Fins .....	6
2.2.1 Description.....	6
2.2.2 Cost Impact of Cast Fins.....	7
2.3 Heat Pipe Processing.....	7
2.3.1 Conventional Copper/Water Heat Pipes .....	7
2.3.2 Heat Pipes for The First Prototype.....	7
2.3.3 Upgraded Heat Pipe Design and Processing.....	8
2.4 Potential Cost Improvements.....	10
2.4.1 Heat Pipes Processed Out-of-Plate .....	10
2.4.2 Complete Heat Pipes Supplied for Installation by Others .....	11

## 1. The BASE Production Cost Estimate

The estimated production cost of a Bleed Air Cooler is \$295,409. The breakdown of this cost is provided in Figure 1 which is the summary sheet of an Excel file, an electronic copy of which has been provided with this report.)

### 1.1 Components of Cost

#### 1.1.1 Pressure Shell

The external pressure shell, including fittings and required pressure testing, is subcontracted to Wiegmann & Rose. This subcontract is shown as Task 6 on Fig. 1. The external shell and its required pressure testing account for \$135,132, or 45% the total.

#### 1.1.2 Internal Materials and Parts

Other materials and parts, (the sum of the materials lines from tasks 3-5 of Figure 1), account for \$55,636, or just under 20% of the total.

#### 1.1.3 Assembly and Processing

The assembly, installation and processing of the heat pipes and other internals, the work performed by Thermacore, accounts for 104,640, or 35% of the total. This estimate is based on the experience of fabricating the recently completed test unit.

### 1.2 Cost Comparisons

#### 1.2.1 Comparison with Production Cost Estimate of 2005

An earlier version of the Bleed Air Cooler was delivered and tested in 2005. The production cost estimate provided at that time was \$197,296. This was about two-thirds of present cost estimate (\$295,409),.

There are two fundamental reasons for the increase in cost:

1. Dramatic Rise in Commodity Prices  
The Cooler is fabricated in large part from copper/nickel alloys which have experienced dramatic increases in material costs.
2. Technical Issues  
The successful resolution of technical issues revealed by shipboard testing of the original HP-BAC has led to dramatic increases in processing costs of the heat pipes. The changes are discussed in Section 2 as well as possible manufacturing changes to minimize this impact.

#### 1.2.2 Cost Comparison with the Masker Cooler.

The original *Masker* and *Prairie* Coolers were manufactured by Wiegmann & Rose in the 1980's. The estimated cost of a standard tube-in-shell heat exchanger (*Masker Cooler*) would be \$125,000-\$150,000 if purchased today<sup>(1)</sup>. Note that this is very comparable to the pressure shell of the HP-BAC as described in Section 1.1.1.

**BLEED AIR COOLER PRODUCTION COST ESTIMATE**

April 1, 2008

	Avg Dir rate
Manager	\$37.55
Sr Engineer	\$35.37
Engineer	\$33.92
Sr. Tech	\$24.55
Technician	\$18.67
CAD	\$29.78

Gov't Approved	
Overhead	200%
G&A	15.35%

	Hours	Direct Cost	Overhead	G&A	Total Cost	10% FEE	PRICE
<b>TASK 1 MATERIALS AND DOCUMENTATION</b>							
Sr Engineer	160	5,659	\$11,318.40	\$2,606.06	\$19,583.66	\$1,958.37	\$21,542.03
Sr Technician	40	982	\$1,964.00	\$452.21	\$3,398.21	\$339.82	\$3,738.03
<b>Task 1 Subtotal</b>		6,641	\$13,282.40	\$3,058.27	\$22,981.87	\$2,298.19	\$25,280.06
<b>TASK 2 SINTERING</b>							
Sr Engineer	0	0	\$0.00	\$0.00	\$0.00	\$0.00	\$0.00
Sr Technician	82.11	2,016	\$4,031.60	\$928.28	\$6,975.68	\$697.57	\$7,673.25
<b>Task 2 Subtotal</b>		2,016	\$4,031.60	\$928.28	\$6,975.68	\$697.57	\$7,673.25
<b>TASK 3 HEAT PIPE ASSEMBLY</b>							
Sr Engineer	0	0	\$0.00	\$0.00	\$0.00	\$0.00	\$0.00
Sr Technician	82.11	2,016	\$4,031.60	\$928.28	\$6,975.68	\$697.57	\$7,673.25
Materials		5,959	\$0.00	\$914.71	\$6,873.71	\$687.37	\$7,561.08
<b>Task 3 Subtotal</b>		7,975	\$4,031.60	\$1,842.98	\$13,849.38	\$1,384.94	\$15,234.32
<b>TASK 4 ASSEMBLY INTO TUBE SHEET</b>							
Sr Engineer	0	0	\$0.00	\$0.00	\$0.00	\$0.00	\$0.00
Sr Technician	209	5,131	\$10,261.90	\$2,362.80	\$17,755.65	\$1,775.57	\$19,531.22
Materials		37,089	\$0.00	\$5,693.16	\$42,782.16	\$4,278.22	\$47,060.38
<b>Task 4 Subtotal</b>		42,220	\$10,261.90	\$8,055.96	\$60,537.81	\$6,053.78	\$66,591.60
<b>TASK 5 Processing Heat Pipes</b>							
Sr Engineer	0	0	\$0.00	\$0.00	\$0.00	\$0.00	\$0.00
Sr Technician	476	11,686	\$23,371.60	\$5,381.31	\$40,438.71	\$4,043.87	\$44,482.58
Materials		800	\$0.00	\$122.80	\$922.80	\$92.28	\$1,015.08
<b>Task 5 Subtotal</b>		12,486	\$23,371.60	\$5,504.11	\$41,361.51	\$4,136.15	\$45,497.66
<b>TASK 6 Weigmann &amp; Rose</b>							
Sr Engineer	0	0	\$0.00	\$0.00	\$0.00	\$0.00	\$0.00
Sr Technician	0	0	\$0.00	\$0.00	\$0.00	\$0.00	\$0.00
Materials		106,500	\$0.00	\$16,347.75	\$122,847.75	\$12,284.78	\$135,132.53
<b>Task 6 Subtotal</b>		106,500	\$0.00	\$16,347.75	\$122,847.75	\$12,284.78	\$135,132.53
					total cost	fee	price
<b>TOTAL</b>					<b>\$268,554.01</b>	<b>\$26,855.40</b>	<b>\$295,409.41</b>
Thermacore In-House					\$95,127.59	\$9,512.76	\$104,640.35

**Figure 1 Production Cost Estimate Summary Sheet**

### 1.3 Estimated Production Cost with heat pipes processed Out-of-Plate

Section 2.4.1 describes the technical basis for this cost improvement. The estimated production cost if the heat pipes are processed out of plate is \$245,390. The cost breakdown is provided in Figure 2. Note that the actual work performed by Thermacore totals \$54,620, with \$190,769 for materials and parts.

<b>BLEED AIR COOLER PRODUCTION COST ESTIMATE</b>											
<b>Processing Heat Pipes Outside Plate</b>											
Avg Dir rate		Gov't Approved									
Manager	\$37.55	Overhead	200%								
Sr Engineer	\$35.37	G&A	15.35%								
Engineer	\$33.92										
Sr. Tech	\$24.55										
Technician	\$18.67										
CAD	\$29.78										
							10%				
							FEE	PRICE			
<b>TASK 1 MATERIALS AND DOCUMENTATION</b>											
		Hours	Direct Cost	Overhead	G&A	Total Cost					
Sr Engineer		160	5,659	\$11,318.40	\$2,606.06	\$19,583.66	\$1,958.37	\$21,542.03			
Sr Technician		40	982	\$1,964.00	\$452.21	\$3,398.21	\$339.82	\$3,738.03			
<b>Task 1 Subtotal</b>			6,641	\$13,282.40	\$3,058.27	\$22,981.87	\$2,298.19	\$25,280.06			
<b>TASK 2 SINTERING</b>											
Sr Engineer		0	0	\$0.00	\$0.00	\$0.00	\$0.00	\$0.00			
Sr Technician		82.11	2,016	\$4,031.60	\$928.28	\$6,975.68	\$697.57	\$7,673.25			
<b>Task 2 Subtotal</b>			2,016	\$4,031.60	\$928.28	\$6,975.68	\$697.57	\$7,673.25			
<b>TASK 3 HEAT PIPE ASSEMBLY</b>											
Sr Engineer		0	0	\$0.00	\$0.00	\$0.00	\$0.00	\$0.00			
Sr Technician		82.11	2,016	\$4,031.60	\$928.28	\$6,975.68	\$697.57	\$7,673.25			
Materials			5,959	\$0.00	\$914.71	\$6,873.71	\$687.37	\$7,561.08			
<b>Task 3 Subtotal</b>			7,975	\$4,031.60	\$1,842.98	\$13,849.38	\$1,384.94	\$15,234.32			
<b>TASK 4 ASSEMBLY INTO TUBE SHEET</b>											
Sr Engineer		0	0	\$0.00	\$0.00	\$0.00	\$0.00	\$0.00			
Sr Technician		112.5	2,762	\$5,523.75	\$1,271.84	\$9,557.47	\$955.75	\$10,513.22			
Materials			37,089	\$0.00	\$5,693.16	\$42,782.16	\$4,278.22	\$47,060.38			
<b>Task 4 Subtotal</b>			39,851	\$5,523.75	\$6,965.00	\$52,339.63	\$5,233.96	\$57,573.59			
<b>TASK 5 Processing Heat Pipes</b>											
Sr Engineer		0	0	\$0.00	\$0.00	\$0.00	\$0.00	\$0.00			
Sr Technician		37.25	914	\$1,828.98	\$421.12	\$3,164.58	\$316.46	\$3,481.04			
Materials			800	\$0.00	\$122.80	\$922.80	\$92.28	\$1,015.08			
<b>Task 5 Subtotal</b>			1,714	\$1,828.98	\$543.92	\$4,087.38	\$408.74	\$4,496.12			
<b>TASK 6 Weigmann &amp; Rose</b>											
Sr Engineer		0	0	\$0.00	\$0.00	\$0.00	\$0.00	\$0.00			
Sr Technician		0	0	\$0.00	\$0.00	\$0.00	\$0.00	\$0.00			
Materials			106,500	\$0.00	\$16,347.75	\$122,847.75	\$12,284.78	\$135,132.53			
<b>Task 6 Subtotal</b>			106,500	\$0.00	\$16,347.75	\$122,847.75	\$12,284.78	\$135,132.53			
							Direct cost	total cost	fee	price	
							\$164,697	<b>TOTAL</b>	<b>\$223,082</b>	<b>\$22,308</b>	<b>\$245,390</b>
							Thermacore In-House	\$49,655.28	\$4,965.53	\$54,620.81	

Figure 2. Production Cost if HPs Processed out of Plate

### 1.4 Estimated Production Cost for Stand-Alone Heat Pipes

Section 2.4.2 describes the technical basis for this cost improvement. The estimated production cost for the heat pipes delivered to a heat exchanger manufacturer who builds the shell and installs the heat pipes into the plate would be 65,427. The cost breakdown is provided in Figure 3. Note that the actual work performed by Thermacore totals \$30,363, with materials, primarily the cast fins, amounting to 35,163.

<b>BLEED AIR COOLER PRODUCTION COST ESTIMATE</b>								
<b>Standalone Deliverable Heat Pipes Only</b>								
<b>Avg Dir rate</b>		<b>Gov't Approved</b>						
Manager	\$37.55	Overhead	200%					
Sr Engineer	\$35.37	G&A	15.35%					
Engineer	\$33.92							
Sr. Tech	\$24.55							
Technician	\$18.67							
CAD	\$29.78							
						10%		
		Hours	Direct Cost	Overhead	G&A	Total Cost	FEE	PRICE
<b>TASK 1 MATERIALS AND DOCUMENTATION</b>								
Sr Engineer		40	1,415	\$2,829.60	\$651.52	\$4,895.92	\$489.59	\$5,385.51
Sr Technician		20	491	\$982.00	\$226.11	\$1,699.11	\$169.91	\$1,869.02
<b>Task 1 Subtotal</b>			1,906	\$3,811.60	\$877.62	\$6,595.02	\$659.50	\$7,254.52
<b>TASK 2 SINTERING</b>								
Sr Engineer		0	0	\$0.00	\$0.00	\$0.00	\$0.00	\$0.00
Sr Technician		82.11	2,016	\$4,031.60	\$928.28	\$6,975.68	\$697.57	\$7,673.25
<b>Task 2 Subtotal</b>			2,016	\$4,031.60	\$928.28	\$6,975.68	\$697.57	\$7,673.25
<b>TASK 3 HEAT PIPE ASSEMBLY</b>								
Sr Engineer		0	0	\$0.00	\$0.00	\$0.00	\$0.00	\$0.00
Sr Technician		82.11	2,016	\$4,031.60	\$928.28	\$6,975.68	\$697.57	\$7,673.25
Materials			5,959	\$0.00	\$914.71	\$6,873.71	\$687.37	\$7,561.08
<b>Task 3 Subtotal</b>			7,975	\$4,031.60	\$1,842.98	\$13,849.38	\$1,384.94	\$15,234.32
<b>TASK 4 ASSEMBLY OF FINNS AND PLUG</b>								
Sr Engineer		0	0	\$0.00	\$0.00	\$0.00	\$0.00	\$0.00
Sr Technician		48.75	1,197	\$2,393.63	\$551.13	\$4,141.57	\$414.16	\$4,555.73
Materials			20,954	\$0.00	\$3,216.36	\$24,169.86	\$2,416.99	\$26,586.85
								\$0.00
<b>Task 4 Subtotal</b>			22,150	\$2,393.63	\$3,767.49	\$28,311.43	\$2,831.14	\$31,142.58
<b>TASK 5 Processing Heat Pipes</b>								
Sr Engineer		0	0	\$0.00	\$0.00	\$0.00	\$0.00	\$0.00
Sr Technician		33.25	816	\$1,632.58	\$375.90	\$2,824.76	\$282.48	\$3,107.24
Materials			800	\$0.00	\$122.80	\$922.80	\$92.28	\$1,015.08
								\$0.00
<b>Task 5 Subtotal</b>			1,616	\$1,632.58	\$498.70	\$3,747.56	\$374.76	\$4,122.32
			Direct cost	total cost		fee	price	
			\$35,663	<b>TOTAL</b>	<b>\$59,479</b>	<b>\$5,948</b>	<b>\$65,427</b>	
			Thermacore In-House	\$27,512.71	\$2,751.27	\$30,263.98		

Figure 3 Production Cost for Stand-alone Deliverable Heat Pipes

## 2. Technical Issues and Changes

### 2.1 Background

The initial version of the Heat Pipe Bleed Air Cooler (HP-BAC) was designed, built and tested in 2004-2005. The fabrication of this unit was subcontracted by Thermacore to Advanced Cooling Technologies, a small business formed by former Thermacore employees. Shipboard testing of this unit aboard the USS Ramage in 2005 fell far short of the design performance. This shortfall was subsequently attributed to three basic causes:

1. Flow Bypass – a very significant proportion of the air and water flows was bypassing the heat pipe fin stacks.
2. Fin Attachment and Count – Due to fabrication issues there were fewer fins than called for in the design models. The attachment of the fins to the heat pipes resulted in a high thermal resistance with a major reduction in fin efficiency.
3. Heat Pipe Operation – In post-operation diagnostic tests at Thermacore, the average thermal resistance of the heat pipes was found to be three times the design value. Only 10% of the heat pipes were found to be performing at design values.

The complete “Post Analysis Test Report” was provided as CLIN 000101, Data Item A001 on March 30, 2007.

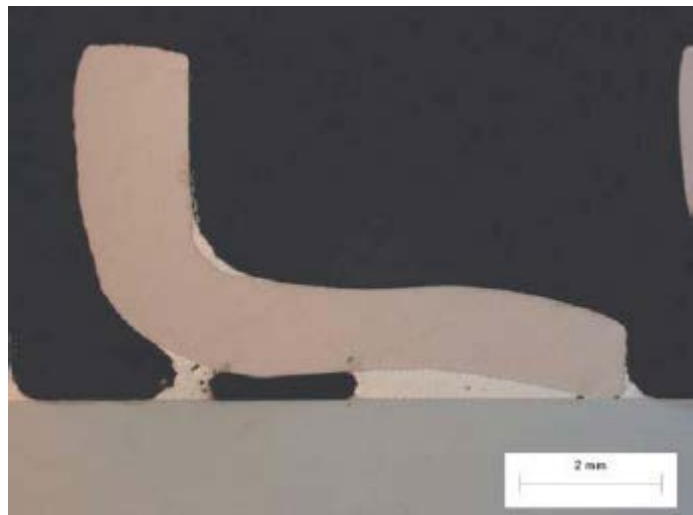
Contract N65540-06-0022 addressed these problems and demonstrated their solution in prototype tests at Wyle laboratories. Correction of the flow bypass issues did not result in significant cost impact. The following sections describe the changes in the fins and heat pipes and their impact on cost.

### 2.2 Change to Cast Fins

#### 2.2.1 Description

One of the shortcomings recognized in the original prototype BAC, was the brazing of the fins to the heat pipes. The original fins were formed, but copper nickel does not draw very well. Figure 1 shows the shape of the fin collar and its impact on fit and braze.

The direct contact between the collar and the heat pipe is limited to a very thin line (at the right in Figure 4). About two-thirds of the available contact length is occupied by thick braze material, and about one-third is simply void. The braze material is a poor conductor compared to the base copper-nickel, and the void is an insulator. The result is a very high thermal resistance between the fin and the heat pipe.



**Figure 4 Fin Braze Detail**  
from EWI Welding Report (N00014-02-C-0106)

Vforge of Lakewood CO developed a casting technique and supplied the fins used to make test article heat pipes. Vforge was contracted by Advanced Technology Institute (ATI) of Charleston, SC to advance the development of semi-solid-material (SSM) casting technology in copper materials. ATI and Vforge have been working with NSWC and Thermacore to improve fin fit and performance. The contributions of Vforge and ATI to this effort are supported under the Copper-Based Casting Technology program, Cooperative Agreement W911NF-04-2-0008 between The Advanced Technology Institute (ATI) and the U.S. Army Research Laboratory (ARL). Even with the cast fins, they had to be machined to produce a truly effective braze joint.

The new fin design produced a factor of six improvement in the conductance between the fin and the heat pipe. The measured performance difference between a new fin that was 0.002" out of spec and a new fin that met the new specs was 15.5%.

A full report on the improved fins was provided as CLIN 000102, on October 10, 2007.

### **2.2.2 Cost Impact of Cast Fins**

The cast fins cost slightly more than 4 times as much as the formed fins (\$8.08 vs. \$2.00). With an investment of 7k per fin type in 4-cavity tooling, the cast fins can be reduced to \$3.00 per fin which is a 50% increase. The production cost assumes the \$3 per fin cost, but does not include the tooling cost. A single HP-BAC requires about 7500 fins.

## **2.3 Heat Pipe Processing**

### **2.3.1 Conventional Copper/Water Heat Pipes**

Thermacore has produced many millions of conventional copper/water heat pipes at nominal cost. They are processed in largely automatic fixtures with the following steps.

1. A measured amount of water is injected into the unsealed heat pipe.
2. The heat pipe is connected to a vacuum header for a measured time. This step causes the water to boil, and the escaping steam purges the pipe of air.
3. The pipe is heated which verifies its operation and causes any remaining non condensable gas (NCG) to accumulate at the cold end of the fill tube. The pipe is then "burped" which removes any remaining air or NCG.
4. The pipe is "pinched off". A set of anvils, somewhat similar to wire cutter jaws, pinch the copper together so it is vacuum-tight and also cuts it off at that point. The clean copper actually cold welds together under this pressure so it is vacuum tight at this point, but a final step dips it in molten solder to ensure a durable seal.

The heat pipes in the HPBAC are made of

### **2.3.2 Heat Pipes for The First Prototype**

The subcontractor for the first prototype HPBAC attempted to adapt copper/water heat pipe techniques for the more complex and challenging processing of copper nickel heat pipes which have already been installed into the 1 3/8" thick tube sheet. By measurement at Thermacore after the shipboard testing, only 10% of the processed heat pipes were fully functional. The process steps employed, and the shortcomings associated with them, are discussed below.

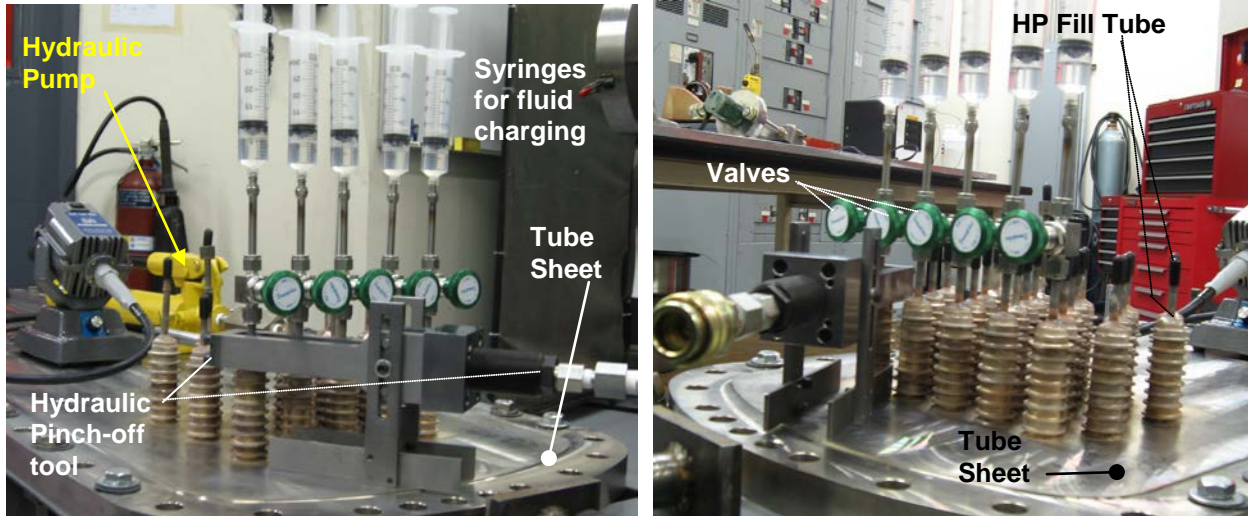


1. After injecting a measured amount of water, the heat pipe was connected to a vacuum header for a manually controlled period of time.
  - a. If the time is too brief, not all the air (NCG) is purged from the pipe. The NCG blocks the condenser and increases the thermal resistance of the heat pipe.
  - b. If the vacuum is applied for too long, too much water is removed from the pipe. This leads to partial dryout, and increased resistance.
2. The pinch-off was performed manually with a device resembling boltcutters. It was performed in a single compression step, with a single set of anvils.
  - a. The manual operation is not capable of exerting consistent pressure, nor of maintaining that pressure while the tube is cut and sealed. Air can leak in while the tube is being cut and welded.
  - b. The copper nickel tube is too hard to be reliably pinched in a single stroke. The large deformations produce cracking.
  - c. Potential problems are increased when only a single set of anvils is used. Narrow, sharper anvils which produce a good seal, will concentrate stresses and make cracking more likely if they are used for the entire pinch. Wide, rounded anvils that do not concentrate stresses, are unlikely to produce a vacuum-tight pinchoff if they are used for the entire pinch.
  - d. The single anvil, single stroke pinch off is likely to leave areas that are not fully sealed, allowing air inleakage when the tube is being welded, and produce cracking in the fill tube near the crimp. Partial cracks can be enlarged by residual stresses from the seal welding. Even the tiniest of cracks will allow leakage that disables the heat pipe operation. 18% of the pipes were found to perform no better than a piece of tubing.
3. The heat pipes were not heat tested and “burped”. Without a heat up test, there was no confirmation that the heat pipes were working. Without the “burping” any residual NCG that had not been removed by the vacuum purge, would remain in the pipe and degraded its performance. More than half the pipes were found to be partially degraded with about twice the thermal resistance as designed. Another 17% were found to be severely degraded with a thermal resistance three or more times higher than designed.

### 2.3.3 Upgraded Heat Pipe Design and Processing

To eliminate the problems described above, and to enable heat pipe performance to not only equal but to surpass the original design level, processing now follows the more demanding procedures used for high temperature liquid metal heat pipes. The changes and their impact on cost are considered below:

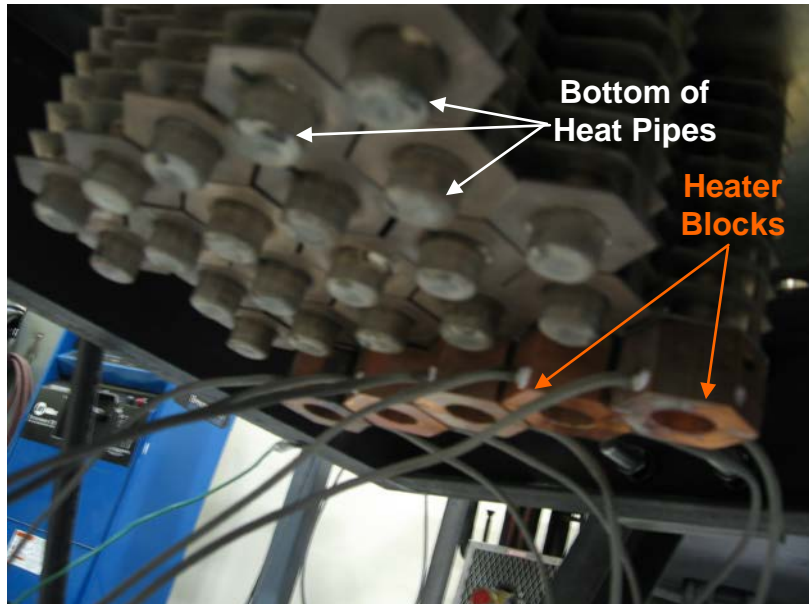
1. A sintered wick was added. This improves the thermal conductance of the heat pipe. The original design was a pure thermosyphon with no wick structure. A less expensive felt wick was tried but did not work well. The sintering process is shown as Task 2 on Figure 4 and accounts for \$7673 of the cost. This cost could be reduced by investing in a larger furnace, but the reduction does not justify the investment for the quantities considered.
2. The heat pipes are vacuum off-gassed for hours rather than seconds. After off-gassing the valves are closed and the vacuum connection is replaced by the calibrated syringes as shown in Figure 5. The (water) working fluid is then injected by slightly opening the valve and reading the level on the syringe. The heat pipes are never exposed to the environment after off-gassing.



**Figure 5 Processing Heat Pipes in Tube Sheet**

3. After the fluid is injected, the evaporator portion (bottom) of the heat pipe is heated. This requires specially designed heater blocks that fit on the bottom of the closely spaced heat pipes as shown in Figure 6.

This power-up exercises the heat pipe and drives any remaining non-condensable gas to the coldest portion of the heat pipe which is the fill tube. Cracking the valve expels this NCG into the syringe. This is the “burping” process. The gas (if any) can be measured in the syringe, as can the amount of liquid that is expelled. Additional water can be injected if necessary to keep the charge within a narrow range. This process is very precisely controlled, unlike the timed vacuum previously used.



**Figure 6 Air Side of Tube Sheet showing Heater Blocks**

4. A hydraulic pinch off tool was designed and fabricated specifically for the HPBAC. Existing tools would not work due to the congestion of the closely spaced heat pipes. It is shown in Figure 5 positioned on a relatively accessible corner heat pipe but it can access any of the heat pipes. The test unit shown in Figure 4 had 25 heat pipes which are all the same length. The actual HP-BAC will include 195 heat pipes of differing lengths and will have even more difficult access.

The pinch-off is made more difficult by the need to change anvils halfway through the pinch-off cycle, a step that is necessary to minimize deformation and preclude cracking.

With the hydraulic tool, a constant pressure is maintained while the fill tube is cut and welded. The tool also maintains a fixed orientation of the anvils while this takes place.

At this time the heat pipes must be processed after they are welded into the tube sheet with the fins brazed on. The brazing is done in a furnace, and processed heat pipes would be over-pressurized at the brazing temperature.

5. The fill-tubes must still be cut off and welded closed. This requires two skilled people working together to accomplish within the congested working conditions entailed by heat pipes installed in the tube sheet.
6. After at least a day, the heat pipes are again energized with the heater blocks to confirm that no cracks, NCG or other degradation has been introduced as a result of the pinch off.

The costs associated with steps 2-6 are shown as Task 5 in figure 1, and total \$66,591.

## **2.4 Potential Cost Improvements**

Almost two-thirds of the cost associated with the HP-BAC are associated with materials and with work that is not performed by or at Thermacore. This section looks at cost improvements that can be made in the Thermacore portion. The outside costs could possibly be improved by ManTech or similar programs.

### **2.4.1 Heat Pipes Processed Out-of-Plate**

Much of the cost and complexity, as well as the need for highly skilled assemblers, would be eliminated if the heat pipes could be processed in the regular shop production spaces rather than after the heat pipes are welded into the tube sheet. This is not possible because the heat pipes cannot survive the time at temperature of the brazing environment. However, if only half the heat pipe was subjected to the brazing environment, it would be practical to process the heat pipe prior to brazing. The key to this process, shown in Figure 7, is that only the Air Side of the heat pipe is brazed in the furnace. It is not clear how such a furnace would be constructed or controlled, but this would cut the cost of the Thermacore portion almost in half. The steps in Figure 7 are explained below.

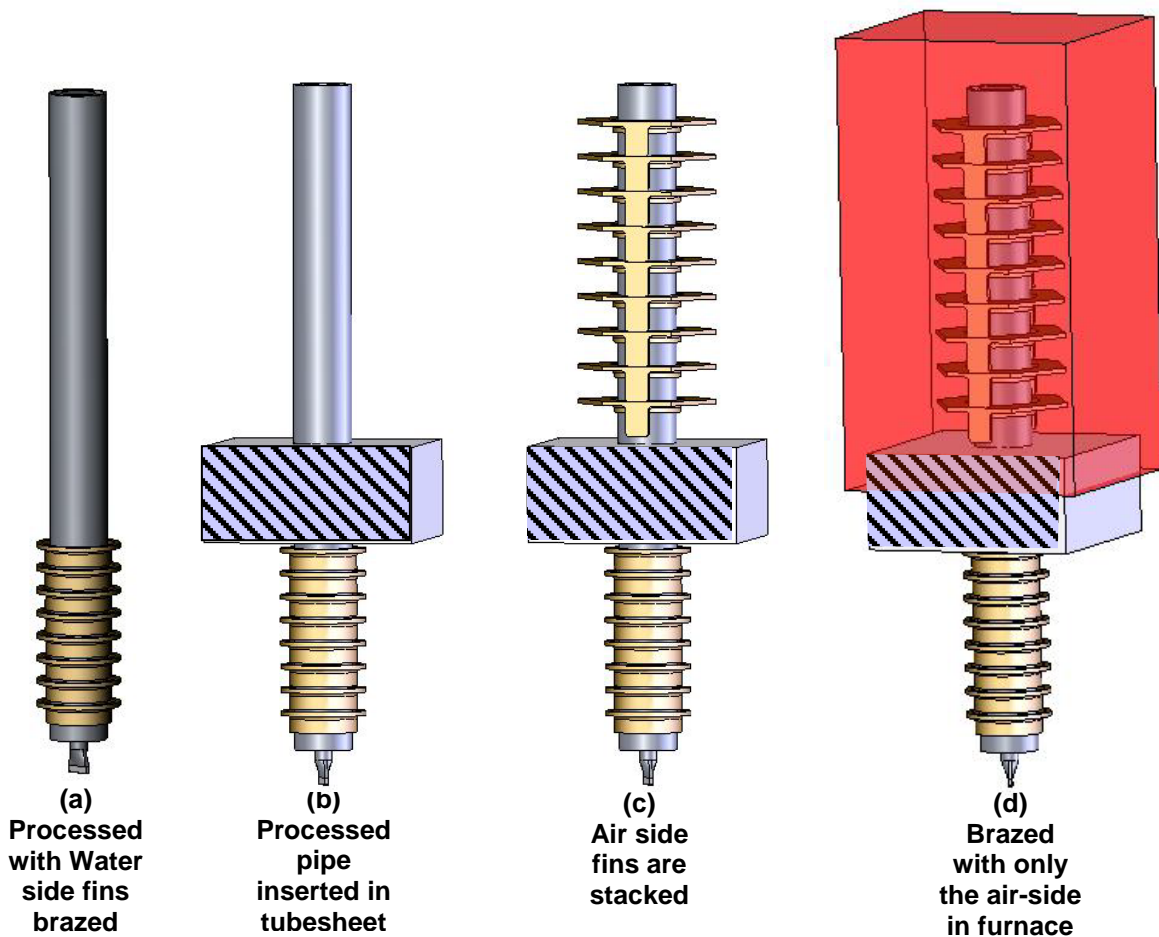
Step 1 The heat pipe is assembled in the normal manner and the water side fins are brazed on prior to processing the heat pipe. The heat pipes are then processed in the standard production environment rather than after insertion into the tube sheet. The end of this step is shown in Figure 7 (a).

Step 2 The processed heat pipe is inserted into the tube sheet, and welded to the sheet on the water side. Figure 7 (b).

Step 3 The air side fins are stacked and locked (either by welding or fixturing). Figure 7 (c).

Step 4 The air side of the HPBAC is then inserted into a furnace. This would more accurately be described as having a furnace with one open side bolted to the HPBAC so that the air side is inside the furnace. In addition to brazing the air side fins to the heat pipes, this step also brazes the heat pipes to the tube sheet itself; essentially flooding the narrow space down to the water side weld. This is actually stronger than welding both sides. 64 (d).

Note that the furnace is on top, which means that the water side of the processed heat pipe is on the bottom. This is upside-down from its operating position. In normal operation, the pipe



**Figure 7 Process Pipes Out of Tubesheet**

operates as a thermosyphon, relying on gravity to return condensed working fluid to the hot end. The wick in these pipes is not used to return condensate as in a typical heat pipe; the wick here used is to distribute condensate around the evaporator and to reduce the delta-T associated with evaporation. By stopping the well short of the water end of the pipe, the condensate will collect there with no means of returning to the hot end. The device will not function as a heat pipe in this orientation, and the temperature at the bottom will be determined by conduction down the tube wall. With the relatively modest conductivity of copper-nickel, the temperature of the condensate (which determines the internal pressure) will remain within a reasonable range.

#### **2.4.2 Complete Heat Pipes Supplied for Installation by Others**

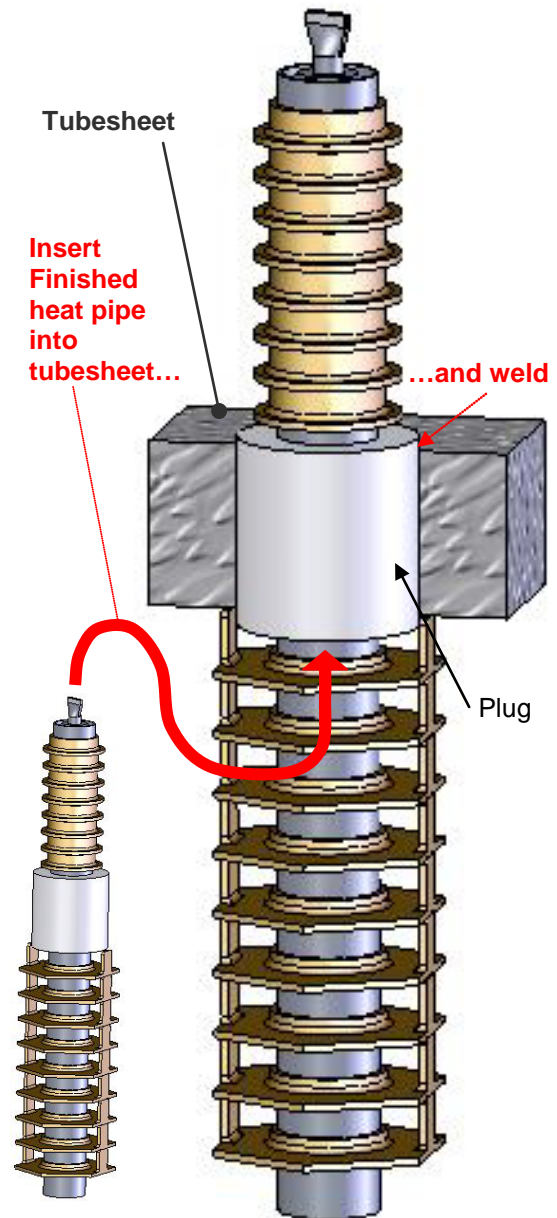
Thermacore's core competency is the design and production of heat pipe. The most economical situation would consist of having Thermacore deliver complete heat pipes, and have the rest of the HPBAC fabricated by those with expertise in this type of equipment. With fins on both sides of the tubesheet it seemed logical that the pipes had to be inserted into the plate before the fins were brazed on. With a special furnace, processed heat pipes with fins on one side can be accommodated as described in Section 2.4.1. This section describes how complete heat pipes can be installed into a tube sheet by those who specialize in the manufacture of conventional bleed are coolers, naval heat exchangers, and related equipment. Such manufacturers can be more

economical, and more likely to benefit from Mantech and similar programs to further reduce the costs.

The heat pipe would be delivered fully processed with all fins brazed on. The deliverable heat pipe is shown in a small view at the lower left of Figure 8. The key to making it installable at a shipfitters facility is the inclusion of a plug (or collar) that is slightly larger in diameter than the waterside fins. Its diameter would be a close fit to the predrilled holes in the tube sheet. The tabs on the air side fins would provide a travel stop. The red arrow shows the heat pipe being inserted into the predrilled hole in the plate.

The main portion of Figure 8 shows the deliverable heat pipe positioned in the plate ready for welding.

The figure shows the heat pipe in its operating orientation with the water side up. The installation of the heat pipe into the plate, and its subsequent weld, should take place with the water side down (as in Figure 7) for the reasons discussed in Section 2.4.1.



**Figure 5 Deliverable Heat Pipes**

#### References

(1). E-Mail from Jack E. Logan, President, Xchanger Manufacturing Corporation, doing business as Wiegmann & Rose; April 10, 2008. They manufactured the original Masker and Prairie Cooler.

## **Appendix F**

### **White Paper - Transition Plans for the Heat Pipe - High Temperature, Heat Exchanger Technology to the NAVY**

Appendix - F  
White Paper - Transition Plans For The Heat Pipe -High Temperature Heat  
Exchanger Technology To The NAVY  
NSWC-Philadelphia, Denis Colahan  
May 2, 2009

**Efforts to Complete Transition:**

As a follow up to the April, 2009, ESTCP-IPR, NSWC prepared this paper to give some background and to address the Pros and Cons with moving forward with the 425 kW heat pipe, heat exchanger, under ESTCP project number WP-0302. This redesign/demonstration, as indicated, focuses on the elimination/reduction of acid cleaning in high temperature salt water heat exchangers. At the April IPR briefing it was reported that the small scale cooler redesign had successfully completed the testing at Wyle labs in CA. This allowed for the ESTCP and NAVSEA 05W cost sharing commitments to be set in place that would set the option 1 on the base contract in place for the fabrication of the full scale preproduction cooler. The preproduction option contract was awarded to Thermacore in Jan 2009. Fabrication of a full scale cooler is currently on going with a completion time of August followed by land base test at Wyle Labs in CA in Sept and a delivery to installation contractor SERCO in Norfolk VA in Sept followed by ship install on the USS Ramage in Oct. Latest Ship operations schedule have identified a early Nov install date. Once installed a 1 year demonstration will follow on-board the USS Ramage, under Ship Change Document (SCD)-291. SCD-291 has been updated with additional information so that it's current for the Oct /Nov 2009 installation. With the ESCTP program office completing their \$1.4 M investment to make available this environmentally friendly technology available. The key element now is to transition the technology to the Navy. NAVSEA 05W and 05Z will be the key offices in transitioning the technology to the NAVY along with support From SURFTECH office.

**Background:**

Over the pass 10 years the Heat Pipe cooler technology has developed to a TRL-7 readiness level. As part of the development of the technology through the OSD ESTCP the goal has been to transfer the technology to the NAVY if technology demonstrated successfully. When NSWC-Phila started with the development of this technology it was based on a NAVY need to improve the performance and reliability of high temperature heat exchangers in Bleed Air Cooler systems. The original intent was to make available a new cooler design that could be used in existing platforms as well as new construction applications. With the cooler now at a transition readiness level the plan is to move the technology to a formal transition process. Over the past years efforts to transition have been difficult at best due to the up front financial commitment that is needed by a Program of Record (POR). NAVSEA 05W has been supportive in helping to move the technology transition forward with the NAVY. With the Pre-production cooler design being readied for a one year demonstration the focus has been to validate the technology for applications with in new construction ships. With NAVY focused on a new run of DDG-51 class ships the use of this technology will be available for use in the Prairie and Masker coolers of the bleed air system. The one year demonstration will be on a Masker cooler onboard the USS Ramage in MER-1. However temperature data comparison will be made between the MER-1 and MER-2 cooler through out the one year demo via a portable data acquisition system installed on the ship.

**Transition Plan**

In any successful technology transition a key element will be the testing of the technology in its operational environment. For this high temperature heat pipe heat exchanger this test will be on board a Navy ship integrated into the bleed air cooling system, i.e. masker cooler. To complete this ship installation, the Navy has moved to a single process for installing new technologies and proven alterations onto Navy ships. This change was done, to better control ship configurations and allow all acquisition and fleet offices better inputs with what alterations and technology inserts are being accomplished, as well as, cost controls for the ever shrinking ships maintenance budgets. This process is identified in the NDE/NM web site and is achieved by entering a Ship Change Document (SCD). Once entered and assigned a number it is reviewed by NAVSEA headquarters, Tech warrant holder, Ships acquisitions offices, the Fleet office of SURFPAC and SURFLANT and the Surface Warfare Enterprises. The Pre-production Cooler will be installed aboard ship under SCD-291 which has been approved for install by these offices at the phase 2 level. The above offices have supplied input to the installation package and have approved. The unique feature with this technology is that it is classified as a non permanent install, which is typical for R&D technology demonstrations, since they usually are evaluated and removed. For the technology to move forward as a bona-fide ship alteration for either a single class or multiple class applications the SCD it will have to be approved to the phase 3 and 4 levels. For this approval a Program of Record (POR) office will need to plan and program monies so that this technology can be realized. With today's environment and a shortage of maintenance funds it would best be realized to transition this technology to the NAVY via new acquisition ship programs or ship modernization i.e.DDG-51. Even though the technology makes a compelling case the cost to retrofit 5 heat exchangers onto a surface combatant ship such as the DDG-51 would be approximately \$1.9 M per ship. This includes cost of heat exchangers with piping and structural changes to be accomplished. The best investment for the NAVY would be to pick one ship to evaluate Technology long term. From this successful test data provide guide lines to the ship builders via performance specifications that would allow them to include this technology in new construction ship applications. A good starting point would be some of the New DDG-51 class ships that the Navy will be building in place of the DDG-1000 class ships.

**Full Scale- Pre-Production Demonstration**

**IPR-FY-09**

- |  |             |
|--|-------------|
| ● Full-Scale Tube Sheet NAVSEA /ESTCP        | Feb 2009    |
| ● Reconfigure Shell Sections Internals       | May 2009    |
| ● Prior to Reinstall Test pre-production     | Aug 2009    |
| ● Install Cooler on Ship                     | Sep 2009    |
| ● Provide ESTCP Interim report for Symposium | Dec 2009    |
| ● Evaluate performance on Ship 1 year Demo   | Oct 2009/10 |
| ● Provide addendum to ESTCP report -final    | Dec 2010    |

**NAVY Technology Transition Plan**

- Complete at sea demonstration via SCD-291 with NAVSEA planned FY- 09 and FY-10 funds
- FY-09-\$30K install contract FY-10- \$70K support testing, FY-11-\$70K remove Ht Ex



## Appendix - F

- NAVSEA 05W and 05Z endorsement to move technology to New Ship Acquisition Offices to start primary focus will be the new DDG-51 class ships in place of the DDG-1000 ships
- Re-Submit FY-09 TTI proposal as FY-10 TIPS proposal Full Scale Production Cooler
- Submitted Heat Pipe – Technical Standards Project (TPS) Data Sheet Support for FY-10 funds
- Resubmit performance specification for Mil-C-19713-B SH, Military Cooler Fluid Systems Bleed Air
- Coordinate Technology applications in both the DDG-1000 and CGX ship programs
- Submit Final Report of technology at sea demonstration to all Navy Acquisition Ship Offices and Fleet Offices.
- Continue coordination with ISEA agent and Tech Warrant holders for other applications of technology

### **POC for Technology Transition to the NAVY**

NAVSEA 05Z Tech Warrant Holder, Michael Felde

NAVSEA 05W Mike O’Neal, Jeff Sachs

PEO-Ships PMS 400D (DDG-51) Brian Rochon DPM

PEO-Ships PMS 500 (DDG-1000) Ed Foster DPM

PEO-Ships PMS 502 (CGX) Steve Parker DPM

SURFTECH S&T office, John Sofia DPM

NSWC-In-service Engineer, James Buttram

NSWC-Tech Lead, Denis Colahan

- **Navy Data Environment (NDE) Website and Navy Modernization Process (NMP) Website ( this is the data base that is used to access the SCD process)**
- <https://www.nde.navy.mil>
  - Website where access to the all NDE modules including EP, ILS, AMPS, and NDE-NM

### **SUMMARY OF EVENTS FOR AT SEA PROJECT DEMONSTRATION**

- Normal system operation is to run both masker coolers in MER-1 and MER-2 at the same time.
- Replace the MASKER cooler in the main engine room (MER-1) with the heat pipe MASKER cooler (test unit).
- Use the MASKER cooler in the main engine room (MER-2) as the MASKER cooler (control unit)
- Clean masker cooler in MER-2 (control) to baseline conditions (like new) for test. Document cleaning solution generated and waste material generated
- Operate both masker coolers, in MER-1 and MER-2 in parallel during ship operating periods. The Bleed air systems operates both coolers simultaneously during ship operating periods ((1 heat pipe-MER-1) , (1conventional shell & tube-MER-2))

Appendix - F

- In conjunction with the collected watch standard data in MER-1. Additional data logger acquisition equipment/instrumentation will be added to the heat pipe demonstration cooler. This will allow NSWC to better monitor the overall heat pipe performance in addition to the 4 temperatures in and out stream temperatures for the air and water required for effectiveness measurement. For the standard shell and tube masker cooler in MER-2, the watch standard collected data will also be used to monitor the performance and 4 thermocouples will be added to monitor the in and out streams of the air and water in this cooler. These 4 temperatures will be the bases of the coolers effectiveness comparison.
- Monitor the performance between the two coolers from the collected data via cooler effectiveness values, see equation (11a & 11b). If possible make a conclusion on the degree of scaling between the two coolers. Conduct inspection as required based on this performance and in accordance with ships Maintenance Requirement Cards (MRC).
- Compare the performances and the degrees of scaling in the 2 MASKER heat exchangers.
- If required during operation based on the cooler’s effective data, or if the cooler is not performing due to failure. Conduct inspections as required with a either a bore-a-scope or by removal of the seawater side, shell section, of the cooler in accordance with the new NSWC procedure for this cooler design. If there is an irrepairable cooler failure the cooler will be secured until it return to homeport. If the cooler is not performing the job or if the cooler should fail.

**NOTE:** The fleet has requested a plan if the coolers should have an irreparable failure. How can NSWC fix or get their system back up and running. If the system would need to be secured, the ship would have to rely on their high pressure air back up for starting the different gas turbine engines. Since bleed air would not be available from MER-1.

- Tear down both Masker coolers at completion of testing to assess and compare effectiveness in avoiding scaling.
- Report results

**Summary of data points collected with acquisition system**

Date and Time	M30277		Delta T	M30322		Delta T	M30277		M30322	
	MER-1 TC-2 AIR-IN (°F)	MER-1 TC-4 AIR-OUT (°F)		MER-2 TC-2 AIR-IN (°F)	MER-2 TC-4 AIR-OUT (°F)		MER-1 TC-1 SW-IN (°F)	MER-1 TC-3 SW-OUT (°F)	MER-2 TC-1 SW-IN (°F)	MER-2 TC-3 SW-OUT (°F)
	554.594	389.354	165.240	568.85	138.2	430.650	70.466	75.02	70.214	77.828
	541.58	362.246	179.3340	560.66	139.856	420.8040	70.952	74.156	70.718	80.672
	544.658	364.874	179.7840	564.368	140.666	423.7020	70.7	73.994	70.484	80.672
	543.794	322.988	220.806	511.34	141.764	369.576	84.344	89.924	83.912	85.928

Appendix - F

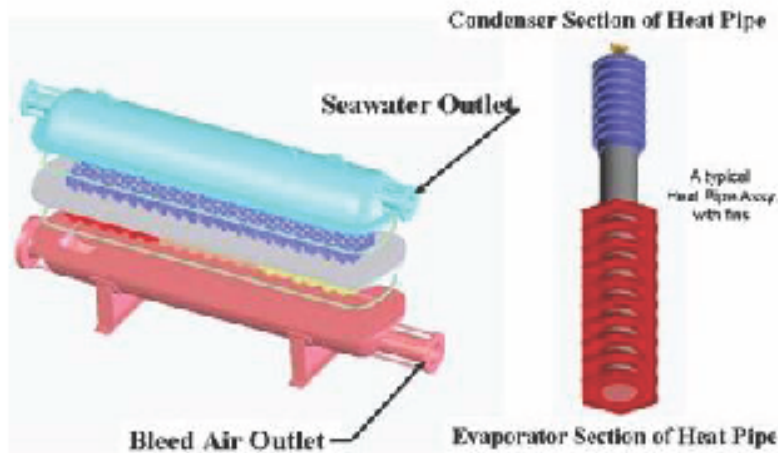
Performance Objectives for at SEA demonstration (From demo Plan)

Type of Performance Objectives	Primary Performance Criteria	Expected Performance (Metric)	Actual Performance
<b>Quantitative</b>	Maintain or exceed performance spec. of existing cooler Table 1-1 and Mil-C-19713, <b>Ref.5</b>	Table 1-1 outlet air temp. < 350°F $T_{ma,o,1} = T_{ma,o,2}$	
	Wall temperatures on water side of heat pipe stay below the scaling temperature 150°F	Attach thermocouples to heat pipes and recorded via data logger $T_{mw,TC-1 \text{ to } TC-9} < 150^\circ\text{F}$	
	Heat effectiveness of coolers	Heat effectiveness calculation shows no degradation in cooler performance ( $e = 0$ to $1$ ) Ideal $e_1 = e_2$ or $e_1$ & $e_2$ values stay constant eqa. (11a & 11b)	
<b>Qualitative</b>			
	Define with OEM's, can the cost to fabricate this type of cooler be < \$50K	Based of production runs of 10, 25 and 50 coolers per year coolers cost is < \$50K	
	Increased reliability of cooler	Maintenance periods move from 1 year to 4 years	
	Elimination of scaling	No visual scaling	
	Reduction in generated waste	Project waste cost reduced 75 % over life of cooler	

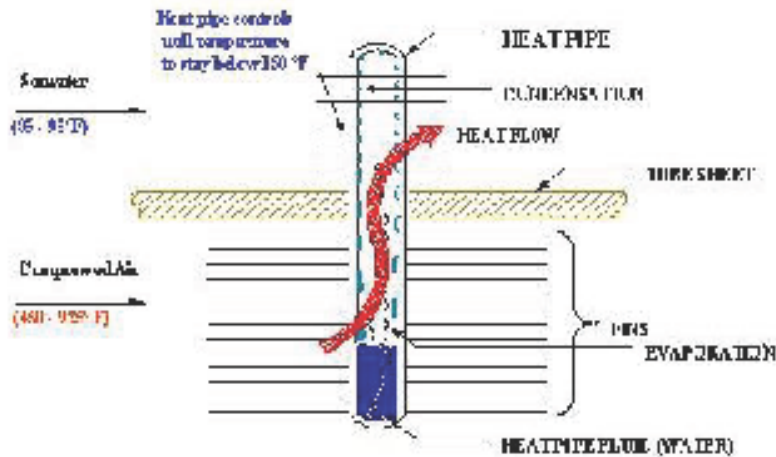


# Advanced 425kW-Heat Pipe Heat Exchanger

## NSWC-Philadelphia Chart- 1



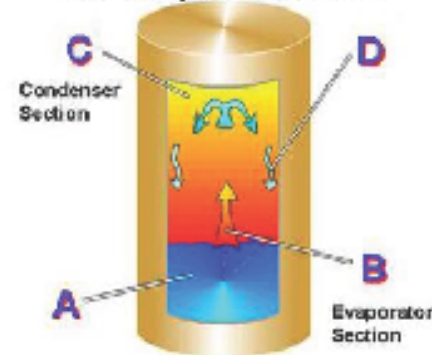
Prototype cooler for DDG-61



HEAT CAUSES PRESSURE GRADIENT - FORCES VAPOR TO COOLER SIDE - GIVES UP LATENT HEAT OF VAPORIZATION TO SW - CONDENSATE RETURNS TO HOT SIDE

Last Updated: 11 May 07

### Heat Pipe Structure



- A. Heat is absorbed in the evaporating section.
- B. Fluid boils to vapor phase.
- C. Heat is released from the upper part of cylinder to the environment; vapor condenses to liquid phase.
- D. Liquid returns by gravity to the lower part of cylinder (evaporating section).



# Advanced 425kW-Heat Pipe Heat Exchanger NSWC-Philadelphia Chart - 2

### Technology

- Heat pipes integrated in a high temp heat exchanger can control salt water coolant wall temperatures to stay below the scale temp of 150 °F. This prevents scaling and maintenance of the exchanger which leads to long service life. Furthers environmental compliance and improves Prairie masker Anti submarine war fare and gas turbine system requirements

### Objectives

- Reduces hazardous chemical usage and disposal
- Reduces total ownership cost and improves availability and reliability of ships system
- Reduce inventory form 13 heat exchangers to 3 heat exchangers

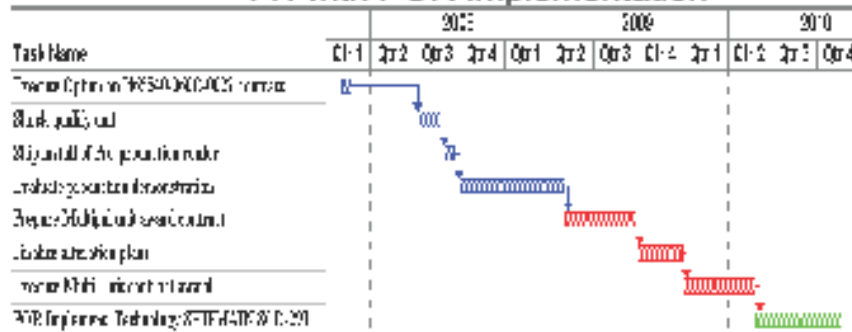
### Participants

PEO-SHIPS, PMS-400, NAVICP, SURFLANT/PAC

### Benefits and Criteria

- Transition from NAVSEA and OSD/ESTCP programs
- Fielding Reduction: 5+ years
- 2 years to implement TTI program of TRL 7 technology
- PEO-SHIPS Endorsement letter
- Approve SHIPMAIN documents SCD-291
- Will address multiple transition participants to maximize transition and cost effectiveness
- Technology has potential to spiral develop to other systems
- Increase gas turbine and anti submarine war fare operational capabilities by a factor of 3

TTI with POR Implementation



Funding (\$K)	FY08	FY09	FY10/11+	Total
OSD/TTI	\$ .650	\$ .325		\$ .975
PEO-SHIPS	\$ .100	\$ .100		\$ .200

Participants

\$5.700+

Last Updated: 11 May 07



Production Prototype



PM: Denis Colahan 05-89 UNCLASSIFIED



# Advanced 425kW-Heat Pipe Heat Exchanger

## NSWC-Philadelphia Chart- 3

UNCLASSIFIED

### OPERATIONAL NEED

**Objective:** Produce 1 pre-production, shock and vibration qualified heat exchanger for demonstration on DDG51/CG47 class ships.

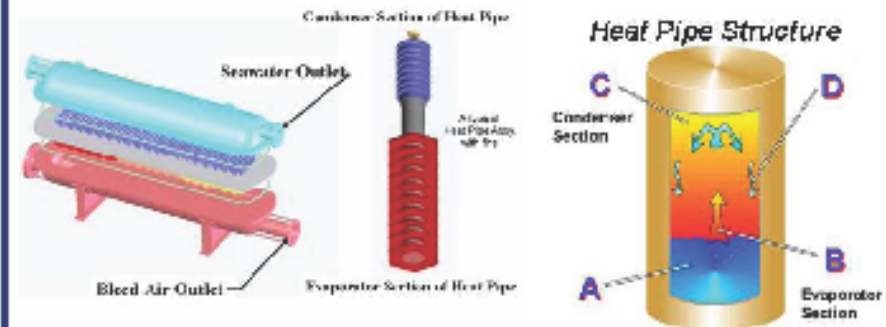
**Value to Naval Warfighter:**

- Prevents scaling and cleaning with hazardous materials
- Reduces total owner ship costs
- Increases heat exchanger service life and reliability

**Gap or Sea Power 21 Area:** Adv. Aux. Equip., Sea Strike

**Impact if Not Addressed:**

- If funded this TTI will accelerate the production 3-5 years.
- Other contributors: N/S R&D office (6.2), N/S Environmental (6.3), OSD/ESTCP, PMS 400, MANTECH-Rapid Response.



- A. A traditional heat pipe is a hollow cylinder filled with a volatile liquid (Water in this case). Heat is absorbed in the evaporating section.
- B. Fluid boils to vapor phase.
- C. Vapor is released down the upper part of cylinder to the condenser where condensation in liquid phase.
- D. Liquid returns by gravity to the lower part of cylinder (evaporating section).

For high temperature seawater cooling applications utilizing the condenser with temperatures below 150°F is the key.

### PROPOSED SOLUTION

**The Technology:**

- Use a controlled intermediate fluid to lower the differential temperature between the heat source and heat sink to prevent scaling and reduce hazmat waste.

**Similar/Related Projects:**

- US Army M109 Palladin - mobile howitzer
- Off-Road equipment differential cooler used in Mining

**TRL:** Current: 7, Projected TRL-9 at end (FY-10)

**Major goals/Schedule by Fiscal year:**

- Reduce hazmat usage/disposal, improved system A<sub>0</sub> FY-12
- Available delivery of to all surface ships via SCD by FY-10
- Implement to all new ship designs in FY-10

### BUSINESS CASE

**Key Metrics:**

- Reduced Hazmat usage/disposal
- Increased reliability A<sub>0</sub> by 40%
- Reduction in NAVICP equipment inventory 13 to 3 HtEx

**Proposed Funding (\$K):**

FY08	FY09	Total
\$650	\$325	\$975

**Partners:**

- FLEET-PAC/LANT, Thermacore, Wiegmann & Rose

**Transition Sponsor:** PEO SHIPS, NAVICP, COMNAVSUR

**POC Contact Info:** Denis Colahan, 215-897-7231

[denis.colahan@navy.mil](mailto:denis.colahan@navy.mil)

UNCLASSIFIED



# Advanced 425kW-Heat Pipe Heat Exchanger NSWC-Philadelphia Chart-4

## TECHNICAL AND BUSINESS READINESS

- Contract with option in place N65540-060C-0022
- NSWC Seaport Contract for ship install in place
- All available ship class drawings available for changes
- LCM's, Fleet, DDG-61 support technology improvement
- Ship Change Documents (SCD-291 approved)

## TRANSITION SUMMARY

- FLEET-PAC/LANT have a vested interest due to reliability
- Reductions in Hazmat & Maintenance \$5M implemented
- NAVICP reductions in equipment inventories of Ht Ex
- Multiple cabinet cooling application for the technology that could help the ships thermal management issues

## TECHNOLOGY TRANSITION PROGRAMMATICS

	FY07	FY08	FY09	FY10	FY11	FY12	FY13	FY14	FY15	FY16	Total
<b>Source</b>											
Transition Funding (\$M)											
TITFE		\$0.650	\$0.325								\$0.975
PEO Ships PE#		\$0.100	\$0.100								\$0.200
Sub-Total	\$0.000	\$0.750	\$0.425	\$0.000	\$0.000	\$0.000	\$0.000	\$0.000	\$0.000	\$0.000	\$1.175
<b>Source</b>											
Integration Funding (\$M)											
PEO Ships PE#				\$2.500	\$2.500						\$5.000
NAVICP PE#				\$0.500	\$0.500						\$1.000
Sub-Total	\$0.000	\$0.000	\$0.000	\$3.000	\$3.000	\$0.000	\$0.000	\$0.000	\$0.000	\$0.000	\$6.000
<b>Source</b>											
Procurement Funding (\$M) and Quantity to be Procured											
PoR & PE#						\$2.500	\$2.500	\$2.500			\$7.500
NAVICP						\$0.500	\$0.500	\$0.500			\$1.500
LANT/PAC						\$2.000	\$2.000	\$2.000			\$6.000
QTY				4	4	8	8	8			
Sub-Total	\$0.000	\$0.000	\$0.000	\$0.000	\$0.000	\$5.000	\$5.000	\$5.000	\$0.000	\$0.000	\$15.000
<b>Total</b>	<b>\$0.000</b>	<b>\$0.750</b>	<b>\$0.425</b>	<b>\$3.000</b>	<b>\$3.000</b>	<b>\$5.000</b>	<b>\$5.000</b>	<b>\$5.000</b>	<b>\$0.000</b>	<b>\$0.000</b>	<b>\$22.175</b>

Organization	Milestone Task	FY08	FY09	FY10	FY11	FY12	FY13	FY14	Total
Thermacor	Contract approval	\$0.300		\$0.500	\$1.500	\$1.800	\$1.800	\$1.800	\$7.700
NSWCDD	Development/design	\$0.350		\$0.200	\$0.500	\$0.200	\$0.200	\$0.200	\$1.650
Altation team	Ox-ing cost			\$0.300					\$0.300
NSWCDD	Test & Evaluation	\$0.100	\$0.225						\$0.325
Contracts	# of Awards & Cert		\$0.200	\$1.500	\$1.000	\$1.000	\$1.000	\$1.000	\$6.700
NAVICP	1 <sup>st</sup> Procurement			\$0.500		\$2.000	\$2.000	\$2.000	\$6.500
PEO-SHIPS	1 <sup>st</sup> Deployment								\$0.000
<b>Total</b>		<b>\$0.750</b>	<b>\$0.425</b>	<b>\$3.000</b>	<b>\$3.000</b>	<b>\$5.000</b>	<b>\$5.000</b>	<b>\$5.000</b>	<b>\$21.675</b>

## **Appendix G**

### **NAVICP LECP ANALYSIS - Bleed Air Cooler Heat Exchanger Replacement – Heat Pipe Design, LECP Analysis**



**Bleed Air Cooler Heat Exchanger  
Replacement - Heat Pipe Design  
LECP Analysis - DRAFT**

**Assumptions & Project Information**

ECP Number:	N/A		
Proposal Submitted by:	NSWCCD Code 824, Denis Colahar		
<b>LECP investment consists of NRE (Nonrecurring expenditure) for engineering and fabrication of full-scale prototype. All other costs for hardware and installation funded by PMS 400 and Fleet.</b>			
Replacement Installation Rate=	<b>20</b>	systems per month, beginning upon completion of full-scale testing and procurement specification development.	
Modification planned to occur by attrition on availability.			
Savings and cost avoidance generated by an estimated	<b>75%</b>	reduction in support costs (both material and labor).	
BAC heat exchanger support :	Average Availability =	<b>\$15,000</b>	per install per year (conservative)
Heat pipe heat exchanger support :	Average Availability =	<b>\$3,750</b>	per install per year (i.e. \$15K every 4 years)
Fleet Labor:	Average Rate in analysis=	<b>\$50</b>	per hour <b>(Reference Only - Fleet labor not included in ROI)</b>
	Hours/Manyear=	<b>2080</b>	<b>(Reference Only - Fleet labor not included in ROI)</b>
	Existing BAC manhours/year, total population=	<b>19362</b>	<b>(Reference Only - Fleet labor not included in ROI)</b>
System Quantity under LECP =	<b>508</b>	(Excludes DECOMs - Analysis assumes no installs on systems DECOMed prior to FY07)	
FY00 System Population =	<b>614</b>	(Active U.S. Navy)	

Analysis conducted in constant FY00 dollars.			
	<u>FY00</u>	<u>FY01</u>	<u>Outyears</u>
NAVICP standard surcharge for new 1H cog items =	16.9%	25%	25%
NAVICP standard surcharge for depot repaired items =	9.9%	25%	25%
NAVICP standard surcharge for new DLR items =	12.7%	25%	25%
Net Present Value Discount Rate (OMB Circ. A-94 Appx. C) =	4.0%		

APPENDIX - G ??

20-Apr-00

BLEEDAIRCOOLER.xls

**Bleed Air Cooler Heat Exchanger Replacement - Heat Pipe Design  
LECP Analysis - DRAFT**

**Fleet & NAVICP Cash Flow**

Fleet Annual Cash Flow															
Fiscal Year	NWCF Expenditures					Non-NWCF Expenditures (w/o Labor)					Annual Fleet Cost Avoidance (w/o labor)	Fiscal Year			
	w/o LECP		with LECP**			w/o LECP		with LECP							
2000	\$	338,606	(-)	\$	338,606	(+)	\$	9,210,000	(-)	\$	9,210,000	=	\$	-	2000
2001	\$	378,253	(-)	\$	628,253	(+)	\$	9,120,000	(-)	\$	9,120,000	=	\$	(250,000)	2001
2002	\$	365,188	(-)	\$	365,188	(+)	\$	8,805,000	(-)	\$	8,805,000	=	\$	-	2002
2003	\$	352,745	(-)	\$	296,754	(+)	\$	8,505,000	(-)	\$	23,955,000	=	\$	(15,394,009)	2003
2004	\$	345,902	(-)	\$	177,928	(+)	\$	8,340,000	(-)	\$	21,090,000	=	\$	(12,582,026)	2004
2005	\$	340,303	(-)	\$	109,805	(+)	\$	8,205,000	(-)	\$	4,607,500	=	\$	3,827,998	2005
2006	\$	332,837	(-)	\$	95,807	(+)	\$	8,025,000	(-)	\$	2,310,000	=	\$	5,952,030	2006
2007	\$	321,639	(-)	\$	84,609	(+)	\$	7,755,000	(-)	\$	2,040,000	=	\$	5,952,030	2007
2008	\$	310,441	(-)	\$	77,610	(+)	\$	7,485,000	(-)	\$	1,871,250	=	\$	5,846,581	2008
2009	\$	297,376	(-)	\$	74,344	(+)	\$	7,170,000	(-)	\$	1,792,500	=	\$	5,600,532	2009
2010	\$	284,312	(-)	\$	71,078	(+)	\$	6,855,000	(-)	\$	1,713,750	=	\$	5,354,484	2010
2011	\$	273,113	(-)	\$	68,278	(+)	\$	6,585,000	(-)	\$	1,646,250	=	\$	5,143,585	2011
2012	\$	267,514	(-)	\$	66,879	(+)	\$	6,450,000	(-)	\$	1,612,500	=	\$	5,038,136	2012
2013	\$	267,514	(-)	\$	66,879	(+)	\$	6,450,000	(-)	\$	1,612,500	=	\$	5,038,136	2013
2014	\$	267,514	(-)	\$	66,879	(+)	\$	6,450,000	(-)	\$	1,612,500	=	\$	5,038,136	2014

NWCF Annual Cash Flow															
Fiscal Year	Sales					Expenditures					NAVICP NWCF Annual Impact	Fiscal Year			
	with LECP		w/o LECP			with LECP **		w/o LECP							
2000	\$	338,606	(-)	\$	338,606	(-)	\$	555,588	(-)	\$	305,588	=	\$	(250,000)	2000
2001	\$	628,253	(-)	\$	378,253	(-)	\$	302,602	(-)	\$	302,602	=	\$	250,000	2001
2002	\$	365,188	(-)	\$	365,188	(-)	\$	292,150	(-)	\$	292,150	=	\$	-	2002
2003	\$	296,754	(-)	\$	352,745	(-)	\$	237,403	(-)	\$	282,196	=	\$	(11,198)	2003
2004	\$	177,928	(-)	\$	345,902	(-)	\$	142,342	(-)	\$	276,722	=	\$	(33,595)	2004
2005	\$	109,805	(-)	\$	340,303	(-)	\$	87,844	(-)	\$	272,242	=	\$	(46,100)	2005
2006	\$	95,807	(-)	\$	332,837	(-)	\$	76,646	(-)	\$	266,270	=	\$	(47,406)	2006
2007	\$	84,609	(-)	\$	321,639	(-)	\$	67,687	(-)	\$	257,311	=	\$	(47,406)	2007
2008	\$	77,610	(-)	\$	310,441	(-)	\$	62,088	(-)	\$	248,353	=	\$	(46,566)	2008
2009	\$	74,344	(-)	\$	297,376	(-)	\$	59,475	(-)	\$	237,901	=	\$	(44,606)	2009
2010	\$	71,078	(-)	\$	284,312	(-)	\$	56,862	(-)	\$	227,449	=	\$	(42,647)	2010
2011	\$	68,278	(-)	\$	273,113	(-)	\$	54,623	(-)	\$	218,491	=	\$	(40,967)	2011
2012	\$	66,879	(-)	\$	267,514	(-)	\$	53,503	(-)	\$	214,011	=	\$	(40,127)	2012
2013	\$	66,879	(-)	\$	267,514	(-)	\$	53,503	(-)	\$	214,011	=	\$	(40,127)	2013
2014	\$	66,879	(-)	\$	267,514	(-)	\$	53,503	(-)	\$	214,011	=	\$	(40,127)	2014

\*\* NRE expenditure for LECP implementation are included in the NWCF expenditures.

## APPENDIX - G

20-Apr-00

BLEEDAIRCOOLER.xls

### Bleed Air Cooler Heat Exchanger Replacement - Heat Pipe Design LECP Analysis - DRAFT

#### IMPLEMENTATION COSTS

\$1,250,000 Engineering development

\$250,000 Engineering and Fabrication of full-scale prototype heat pipe heat exchanger

**\$1,500,000 Nonrecurring Investment**

\$35,560,000      508      Production unit procurement and installation      **\$70,000**      each

**\$35,560,000 Equipment Investment**

**\$37,060,000 Total Project Investment**

**\$36,810,000 Non-BOSS III Investment (PMS 400, Fleet)**

**\$250,000 BOSS III LECP Investment (Full-scale prototype engineering and fabrication only)**

**Bleed Air Cooler Heat Exchanger  
Replacement - Heat Pipe Design  
LECP Analysis - Draft**

**Hazardous Materials & Labor Cost Comparison**

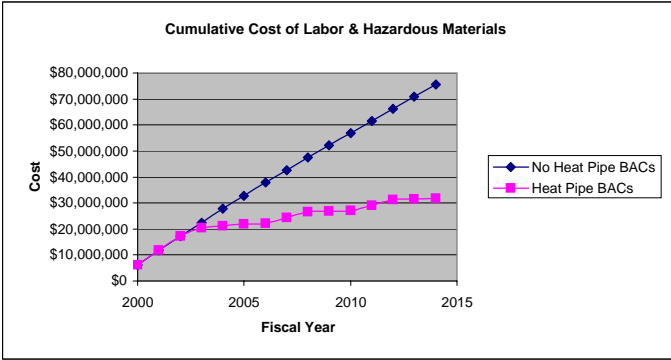
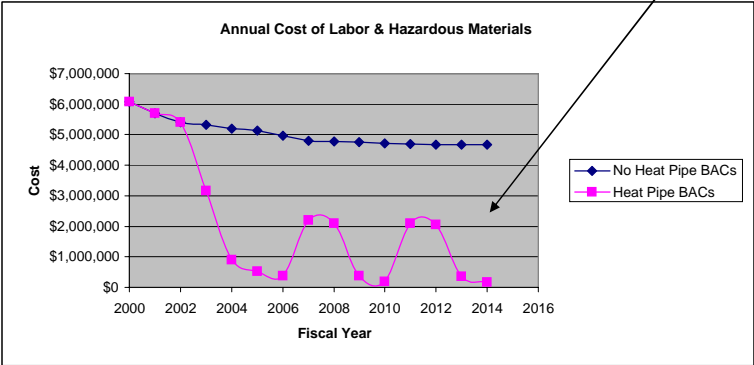
**Total Cost of Labor & Hazardous Materials w/o Implementation of Heat Pipe BACs**

Fiscal Year	Total Cost (Hazmat)	Total Cost (Labor)	Total Cost (Combined)	Total Cost (Cumulative)
2000	\$5,111,120	\$968,100	\$6,079,220	\$6,079,220
2001	\$4,734,253	\$958,640	\$5,692,893	\$11,772,113
2002	\$4,489,937	\$925,529	\$5,415,466	\$17,187,579
2003	\$4,420,227	\$893,995	\$5,314,222	\$22,501,801
2004	\$4,324,847	\$876,651	\$5,201,498	\$27,703,299
2005	\$4,280,314	\$862,460	\$5,142,775	\$32,846,074
2006	\$4,133,183	\$843,540	\$4,976,723	\$37,822,797
2007	\$3,991,466	\$815,159	\$4,806,625	\$42,629,422
2008	\$3,999,586	\$786,778	\$4,786,364	\$47,415,786
2009	\$3,999,586	\$753,667	\$4,753,253	\$52,169,039
2010	\$3,999,586	\$720,557	\$4,720,142	\$56,889,181
2011	\$3,999,586	\$692,176	\$4,691,761	\$61,580,942
2012	\$3,999,586	\$677,985	\$4,677,571	\$66,258,513
2013	\$3,999,586	\$677,985	\$4,677,571	\$70,936,084
2014	\$3,999,586	\$677,985	\$4,677,571	\$75,613,655

**Total Cost of Labor & Hazardous Materials w/ Implementation of Heat Pipe BACs**

Fiscal Year	Total Cost (Hazmat)	Total Cost (Labor)	Total Cost (Combined)	Total Cost (Cumulative)
2000	\$5,111,120	\$968,100	\$6,079,220	\$6,079,220
2001	\$4,734,253	\$958,640	\$5,692,893	\$11,772,113
2002	\$4,489,937	\$925,529	\$5,415,466	\$17,187,579
2003	\$2,422,395	\$752,091	\$3,174,486	\$20,362,065
2004	\$456,347	\$450,939	\$907,286	\$21,269,351
2005	\$249,198	\$278,289	\$527,487	\$21,796,839
2006	\$133,598	\$242,813	\$376,411	\$22,173,250
2007	\$1,989,712	\$214,433	\$2,204,145	\$24,377,394
2008	\$1,889,568	\$196,695	\$2,086,263	\$26,463,657
2009	\$182,526	\$188,417	\$370,943	\$26,834,600
2010	\$0	\$180,139	\$180,139	\$27,014,739
2011	\$1,927,491	\$173,044	\$2,100,535	\$29,115,275
2012	\$1,889,568	\$169,496	\$2,059,064	\$31,174,339
2013	\$182,526	\$169,496	\$352,023	\$31,526,362
2014	\$0	\$169,496	\$169,496	\$31,695,858

**Note:** Peaks and Valleys in annual expenses derive from the increased periodicity of the Heat Pipe BACs. These BACs only need to be cleaned once every four years, whereas the current BACs need to be cleaned annually. The Peaks on the graph are periods where the Heat Pipe BACs are being cleaned. The valleys



20-Apr-00

**Bleed Air Cooler Heat Exchanger  
Replacement - Heat Pipe Design  
Projections Summary**

BLEEDAIRCOOLER.xls

Fiscal Year	NWC			DOD			Fleet		
	<u>Investment</u>	<u>Cost Avoidance</u>	<u>Cost Avoidance</u>	<u>Investment</u>	<u>Cost Avoidance</u>	<u>Cost Avoidance (w/o labor)</u>	<u>Investment</u>	<u>Cost Avoidance</u>	<u>Cost Avoidance (w/o labor)</u>
2000	(\$250,000)	\$0	(\$250,000)	(\$1,500,000)	\$0	(\$1,500,000)	\$0	\$0	\$0
2001	\$0	\$0	\$0	\$0	\$0	\$0	(\$250,000)	\$0	(\$250,000)
2002	\$0	\$0	\$0	\$0	\$0	\$0	\$0	\$0	\$0
2003	\$0	\$40,413	\$40,413	(\$16,800,000)	\$1,390,413	(\$15,409,587)	(\$16,800,000)	\$1,405,991	(\$15,394,009)
2004	\$0	\$121,238	\$121,238	(\$16,800,000)	\$4,171,238	(\$12,628,762)	(\$16,800,000)	\$4,217,974	(\$12,582,026)
2005	\$0	\$166,365	\$166,365	(\$1,960,000)	\$5,723,865	\$3,763,865	(\$1,960,000)	\$5,787,998	\$3,827,998
2006	\$0	\$171,080	\$171,080	\$0	\$5,886,080	\$5,886,080	\$0	\$5,952,030	\$5,952,030
2007	\$0	\$171,080	\$171,080	\$0	\$5,886,080	\$5,886,080	\$0	\$5,952,030	\$5,952,030
2008	\$0	\$168,049	\$168,049	\$0	\$5,781,799	\$5,781,799	\$0	\$5,846,581	\$5,846,581
2009	\$0	\$160,977	\$160,977	\$0	\$5,538,477	\$5,538,477	\$0	\$5,600,532	\$5,600,532
2010	\$0	\$153,905	\$153,905	\$0	\$5,295,155	\$5,295,155	\$0	\$5,354,484	\$5,354,484
2011	\$0	\$147,843	\$147,843	\$0	\$5,086,593	\$5,086,593	\$0	\$5,143,585	\$5,143,585
2012	\$0	\$144,812	\$144,812	\$0	\$4,982,312	\$4,982,312	\$0	\$5,038,136	\$5,038,136
2013	\$0	\$144,812	\$144,812	\$0	\$4,982,312	\$4,982,312	\$0	\$5,038,136	\$5,038,136
2014	\$0	\$144,812	\$144,812	\$0	\$4,982,312	\$4,982,312	\$0	\$5,038,136	\$5,038,136

= "Break Even" Year

## Navy Fleet Total LECP Investment and Savings

		FY 96	FY 97	FY 98	FY 99	FY 00	FY 01	FY 02	FY 03	FY 04	FY 05	FY 06	FY 07	FY 08	FY 09	FY 10	FY 11
<b>All TYCOMS</b> <b>(Dollars are in thousands)</b>	Investment								16,380	16,380	1,914						
	Gross Savings								1,371	4,113	5,651	5,811	5,811	5,703	5,456	5,211	5,000
	Net Savings								-15,009	-12,267	3,738	5,811	5,811	5,703	5,456	5,211	5,000
<b>SURFLANT Active Ships Total</b> <b>(Dollars are in thousands)</b>	Investment								8,680	9,100	1,042						
	Gross Savings								726	2,285	3,076	3,163	3,163	3,150	2,957	2,797	2,727
	Net Savings								-7,954	-6,815	2,035	3,163	3,163	3,150	2,957	2,797	2,727
<b>SUBLANT Submarines Total</b> <b>(Dollars are in thousands)</b>	Investment																
	Gross Savings																
	Net Savings																
<b>SURFLANT Reserve Ships Total</b> <b>(Dollars are in thousands)</b>	Investment									140	15						
	Gross Savings									35	46	47	47	48	48	48	48
	Net Savings									-105	30	47	47	48	48	48	48
<b>SURPAC Active Ships Total</b> <b>(Dollars are in thousands)</b>	Investment								7,700	7,140	857						
	Gross Savings								644	1,793	2,529	2,601	2,601	2,506	2,452	2,366	2,225
	Net Savings								-7,056	-5,347	1,673	2,601	2,601	2,506	2,452	2,366	2,225
<b>SUBPAC Submarines Total</b> <b>(Dollars are in thousands)</b>	Investment																
	Gross Savings																
	Net Savings																
<b>SURPAC Reserve Ships Total</b> <b>(Dollars are in thousands)</b>	Investment																
	Gross Savings																
	Net Savings																
<b>MSC Ships Total</b> <b>(Dollars are in thousands)</b>	Investment																
	Gross Savings																
	Net Savings																
<b>Shore Site Total</b> <b>(Dollars are in thousands)</b>	Investment																
	Gross Savings																
	Net Savings																
<b>Training Site Total</b> <b>(Dollars are in thousands)</b>	Investment																
	Gross Savings																
	Net Savings																