

UNCLASSIFIED



Australian Government
Department of Defence
Defence Science and
Technology Organisation

Blast Performance of Four Armour Materials

C. Choi¹, M. Callaghan² and B. Dixon¹

¹ **Land Division**
Defence Science and Technology Organisation

²**The University of Manchester**

DSTO-TR-2888

ABSTRACT

This investigation compared four conventional vehicle armour materials for performance under blast loading. The parameters measured were resistance to deformation, mechanical toughness and metallurgical microstructure. It was found that two of these, the M steel and A steel, showed the least deformation and M steel showed better shock energy absorption.

B steel had high toughness but showed significant deformation under blast loading; particularly when subjected to multiple hits.

H steel showed intermediate properties between M steel and B steel.

It is concluded that M and A steels provide the best performance for use on vehicles that may be subjected to explosive charges.

RELEASE LIMITATION

Approved for Public Release

UNCLASSIFIED

UNCLASSIFIED

Published by

*Land Division
DSTO Defence Science and Technology Organisation
506 Lorimer St
Fishermans Bend, Victoria 3207 Australia*

*Telephone: 1300 DEFENCE
Fax: (03) 9626 7999*

*© Commonwealth of Australia 2013
AR-015-705
August 2013*

APPROVED FOR PUBLIC RELEASE

UNCLASSIFIED

UNCLASSIFIED

Blast Performance of Four Armour Materials

Executive Summary

This work compared four commercially available candidate armour steels, possessing a range of steel chemistries and mechanical properties, with respect to their resistance to multiple blast loadings. Both toughness and deformation resistance of the steels were assessed by bulge depth measurements and cracking assessments using the Explosion Bulge Test (EBT). A number of conclusions may be drawn from these investigations and are summarised as follows:

All steels tested were provided in the Q&T condition, possessing tempered martensitic microstructures. Steels H, A and M possessed very similar microstructures at the metallurgical levels examined in this work. Steel B has leaner carbon content and appears to have undergone a greater tempering temperature, producing good toughness and greater ductility, but less hardness.

Multiple blast testing showed that steel A and steel M possessed the best resistance to deformation and rupture. They are strong candidates for blast-resistive armour material. Steel M showed the best resistance in terms of bulge depth deformation and toughness. It should also be noted that Steel M possessed approximately 30% higher Charpy impact toughness than A.

Steel B showed good rupture resistance, toughness and the highest deformation under blast loading, particularly when subjected to multiple hits. This is consistent with the hereby tempered microstructure observed for this steel.

Steel H showed intermediate deformation properties, placed between steel M and steel B. It was also demonstrated to be the most brittle of the four steels, withstanding only 5 blasts instead of 7, with cracking occurring in the plate material. This behaviour corresponded to the steel having the lowest Charpy V-notch impact toughness results, as well as a higher carbon content of all steels tested.

For all steels the greatest deformation occurred in the first blast. This suggests that blasting may have a work hardening effect that may be used, in future, to produce blast resistant steels.

UNCLASSIFIED

UNCLASSIFIED

This page is intentionally blank

UNCLASSIFIED

Authors

Chang Ho Choi

Land Division

Defence Science and Technology Organisation

Chang Choi obtained a Masters degree in Materials Science at the Oregon State University and undertook PhD study at the University of Illinois and later at the University of New South Wales, where he received a PhD with a thesis on superconductors. He has been employed as a materials scientist at DSTO Maritime Platforms Division since 1998. During the period 1998 to 2006, he worked with the metallurgy section. From 2006 to 2009, he worked in the biology section and from 2009 onward, in the Armour Mechanics and Vehicle Survivability group and later Land Division.

Mark Callaghan

School of Mechanical, Aerospace and Civil

Engineering

The University of Manchester

Mark Callaghan undertook his PhD at the Australian Nuclear Science and Technology Organisation, researching high temperature fatigue behaviour and modelling of ferritic pressure vessel steel, for which he was awarded the degree at the University of Technology, Sydney in 2009. He joined the University of Wollongong in 2008 as a Research Fellow, where he undertook research into armour and high strength steels subjected to static and dynamic loadings, weldability and welding metallurgy of these materials as a function of welding processes and simulations. In 2012, Mark was appointed as Research Associate at The University of Manchester, researching thick-walled corrosion resistant materials for high-temperature high-pressure service.

UNCLASSIFIED

Brian Dixon

Land Division

Defence Science and Technology Organisation

Brian Dixon is Head of Armour Mechanics and Vehicle Survivability Group in the Land Division of Defence Science and Technology Organisation. He has been employed at DSTO since 1978, undertaking experimental development and fundamental studies into weld metal solidification cracking in steels and stainless steels. He has also undertaken extensive work on improving the weld zone toughness of high strength steels. During 1989 and 1990 Brian worked at Kockums Laboratory in Sweden as part of DSTO's contribution to the submarine project. Since 2001, Brian has worked in a number of developmental positions, including Director, Program Office (Maritime), STCC for M1 and M6 and S&T Adviser for JP 2048.

UNCLASSIFIED

Contents

1. INTRODUCTION.....	1
2. EXPERIMENTAL	2
2.1 Explosive Test Setup	2
2.2 Explosive Bulge Test Procedure.....	3
2.3 Materials	4
3. RESULTS AND DISCUSSION	5
3.1 Microstructures of steels.....	5
3.2 EBT results: Bulge depth comparison.....	7
4. CONCLUSIONS.....	10
5. REFERENCES	12
6. ACKNOWLEDGEMENTS	11

This page is intentionally blank

1. Introduction

Steel armour is commonly used for the protection of vehicles exposed to military events such as penetrating weapons (including shaped-charge penetrators, long-rod penetrators, etc.) and blast loading from exploding mines or buried improvised explosive devices (IEDs). Until relatively recently, the main threat has been from penetrators and the steels have been developed with a primary focus of defeating these weapons. Consequently, the steels used for modern armour applications have optimum properties, notably hardness and strength, to defeat these weapons. They are also designed to have an adequate level of toughness to avoid brittle failure in service and other manufacturing qualities such as straightness and weldability to assist in fabrication and repair of the vehicles.

In recent years, the threats have changed and vehicles are more likely to be exposed to a blast loading due to mines or large quantities of explosive material than by penetrating weapons. This has meant that steels that were optimised for earlier, conventional threats may not be appropriate in the current environment. There is therefore a requirement to identify those steel properties that give optimum performance under blast loading and to test candidate materials against those property requirements, of which toughness and energy absorption are paramount. The toughness of steel is due to primary factors including composition, heat treatment, microstructure and grain-size. Other factors include solid solution strengthening through elemental addition, inclusion size and distribution [1, 2].

Armour materials are required to have high toughness to defend against rupture by the interaction of high velocity fragments and blast forces [3]. Moreover, good toughness is necessary to reduce the risk of experiencing undesirable failure modes such as brittle fracture, cracking and spalling. Extensive experience with the blast performance of high strength steels has been obtained by DSTO from work on the hulls of submarines [4] and armour steels [5, 6], where toughness combined with high strength is considered to be essential.

A further requirement is the ability to absorb energy from the blast without the steel armour undergoing excessive plastic and elastic deformation. In the case of a military vehicle, significant absorption of energy is critical in reducing the load transmitted to the vehicle occupants. This is analogous to modern cars, which are designed with 'crumple zones' that gracefully absorb energy from a collision and thereby reduce injury to the occupants. However, as with motor vehicles, the extent of deformation also needs to be contained to avoid transmitting loads to occupants. The amount of energy absorbed by the armour plate is related to the yield strength (or hardness) of the metal and its ductility, i.e., ability to deform and elongate. In most circumstances, the energy absorption capability is directly related to the area under the conventional stress/strain curve.

2. Experimental

2.1 Explosive Test Setup

In the report, the toughness and deformation resistance of four commercial armour steels are evaluated.

The toughness of the steel materials was measured using the Explosion Bulge Test (EBT) [7]. The EBT utilises a standard explosive loading rate that is similar to loading rates typically seen in military events and it applies a reproducible energy to the plate so that materials can be directly compared. The test configuration is shown in Figure 1. It comprises a donut shaped die block on which the test plate is placed. A cardboard box, with a depth chosen to achieve the specified 320 mm standoff distance, is tightly fitted over the plate. A 2.3 kg explosive charge is placed on the centre of the topside of the box, which has been diagonally cross-marked to identify the correct charge placement location.

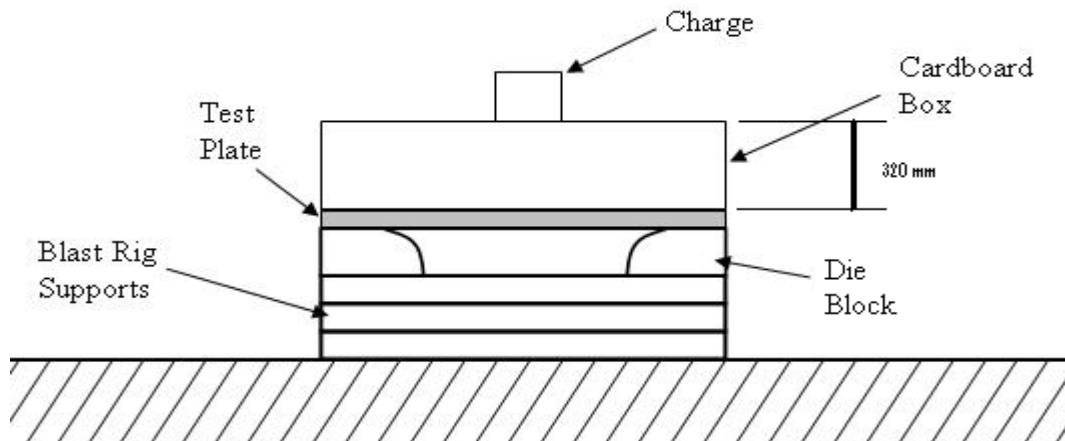

Figure 1: EBT configuration.

In this work, the EBT was used to directly compare four commercially available armour steels, designated in this report as steels H, B, A and M, for toughness and deformation resistance. All steels underwent a quench and temper (Q&T) process using commercial processing technologies. However, it was noted that the metals possessed a range of chemistries and hardnesses and have different microstructures that can often give rise to performance variations under conditions of rapid loading [8].

To assess the materials for toughness, crack starter weld beads were deposited on the centre of the test plates. These weld beads are composed of hard-facing material that is inherently brittle and, under blast loading, act as a 'crack starter' to force the initiation of brittle cracking in the weld zone and hence into the parent plate. After blasting, the depth of the bulge of the plate is measured to provide an indication of deformation resistance (elongation) and toughness of the steel is determined from the appearance of the fracture surface on any region of the plate that has fractured. The steel is subjected to multiple blasts in order to compare toughness and deformation performance. In addition to EBT

results, the steels were compared using standard mechanical tests and metallographic inspection. Each of the steel plates was subjected to multiple explosive blasts, typically a maximum of seven blasts per test plate.

2.2 Explosive Bulge Test Procedure

Before testing, each test plate was plasma-cut to dimensions of 760 mm x 760 mm to match the dimensions of the die block¹. Two opposing corners of each plate were drilled through to clamp the plate with a bolted shackle. This was required to avoid the blasted plates impacting the ceiling of the blast chamber. A type 'k' thermocouple was then welded to a corner on the top side of the plates to monitor the temperature of the plate to ensure the correct test temperatures were achieved prior to testing.

EBT equipments were carried out at approximately -18° C for each test plate. Images of the test plate, blast chamber, and a schematic of the test plate are shown in Figure 2, identifying the location of the crack starter weld, blast chamber, thermocouple, and clamp positions.

The stand off distance was 320 mm in all cases. 2.3 kg PE4 explosive charges were used for all test plates. The PE4 was packed into 160 mm diameter cylinders, which were made of cardboard.

Finally, the top and bottom sides of each test plate were wrapped with cardboard to insulate the plate so that its temperature did not increase rapidly while transporting the plate from the temperature conditioning chamber to the blast chamber and while warming the plate to the correct test temperature (-18° C). To achieve the testing temperatures the plates were placed in the temperature conditioning chamber at approximately -40° C and left to equilibrate overnight before testing.

Immediately prior to each test, the plate was removed from the conditioning chamber and placed on the die block. The thermocouple was then connected to a DT500 series 'datalogger' device to monitor plate temperature. The charge was detonated when the test plate had warmed to the required test temperature. Bulge depth measurements and macro images of the region adjacent to the hard-facing weld bead were taken after testing.

¹ The dimension from the top of the die block to the bottom of the blast rig supports is 250 mm.

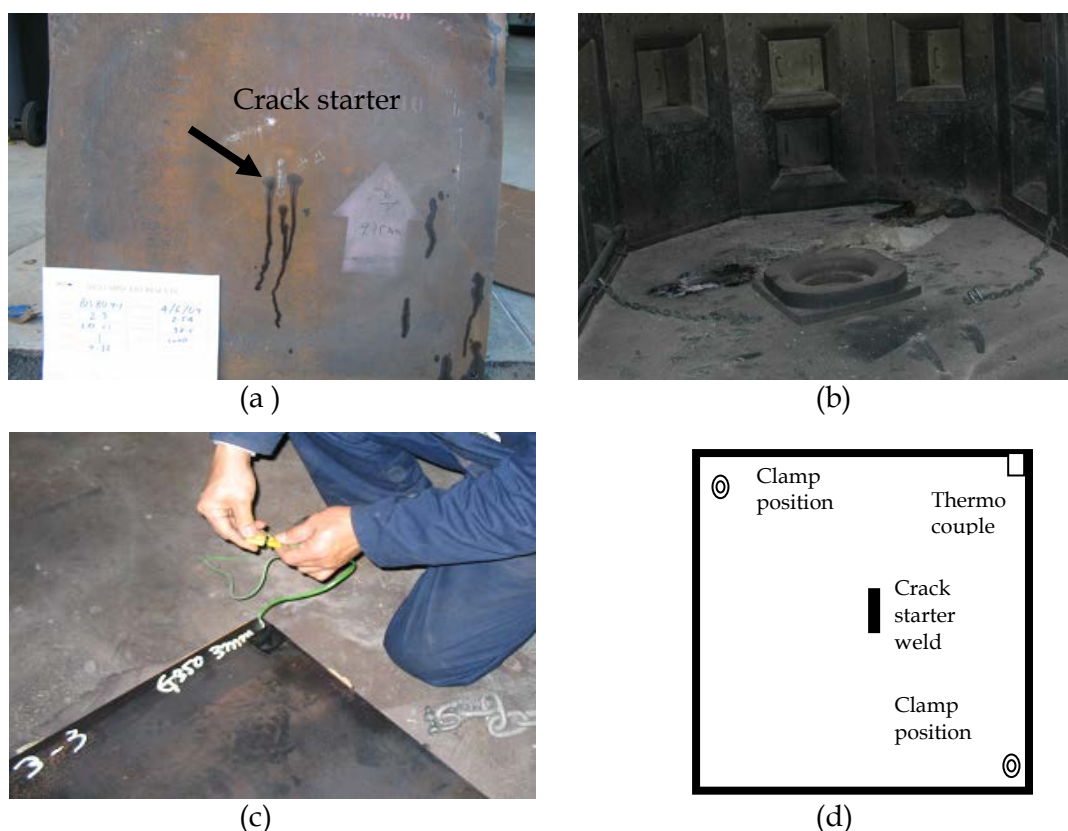

Figure 2: (a) weld bead on the centre of the underside of the plate (arrowed) (b) View of the blast chamber, (c) thermocouple position on the edge of the test plate, and (d) the schematic diagram of the test plate.

2.3 Materials

The compositions and plate thicknesses of the four commercial armour steels (designated as steels B, H, A and M) are given in Table 1. The mechanical properties including hardness, ultimate tensile strength (UTS) and elongation, as well as Charpy V-Notch (CVN) impact toughness supplied in manufactured data sheets are given in Table 2.

Table 1: Compositions and thicknesses of the steels under investigation.

Steel	Thickness* (mm)	C	P	Mn	Si	Ni	Cr	Mo	Cu	S	Al
B	15.5	0.17	0.014	1.09	0.20	-	-	0.20	0.013	0.005	0.027
H	15.5	0.29	0.013	0.30	0.30	0.19	0.99	0.25	0.012	0.005	0.035
A	15.5	0.21	0.01	1.2	0.3	2.5	1.0	1.2		0.010	
M	15.5	0.22	<0.15	1.5	0.5	2.0	1.0	0.6		<0.005	

*nominal thickness

Table 2: Mechanical properties of the steels under investigation.

Steel	Hardness (H _B)	UTS* (MPa)	CVN* (J @ -40° C)	Elongation* (%)
B	255	790	40	18
H	350	1140	22	16
A	440	1450	35	12
M	440	1450	48	13

*average values

The microstructures of these steels were assessed prior to testing and metallographic preparation was conducted in accordance with standard grinding and polishing techniques for steels. Steel samples were then etched using 2% Nital solution to reveal microstructures and optical microscopy was undertaken using a Leica DMR light microscope.

3. Results and Discussion

3.1 Microstructures of steels

It is generally accepted that a tempered martensitic microstructure is the most desirable condition for armour steel plate to achieve desired hardness and toughness properties [9]. All the steels investigated in this work were supplied in the quenched and tempered (Q&T) heat-treatment condition. The microstructures of the steel plates are shown in Figure 3. The microstructures and hence their hardenabilities are a result of the Q&T processing methods used and the steel chemistry. Austenitising temperature and quenching rate, as well as tempering temperature and time are expected to vary from manufacturer to manufacturer and grade to grade, depending on the desired microstructure and mechanical properties required.

The microstructures observed for steels B, H, A and M are typical tempered martensitic microstructures possessing lath martensite packet morphology. Steels H, A and M appear similar in microstructure with respect to phase constituent and morphology. Steels A and M contained grain size of 10-15 μm , which were slightly finer than steel H (approximately 10-20 μm). The mechanical properties shown in Table 2, especially with respect to hardness and tensile strength, correspond sensibly with the microstructures observed for these steels

The morphology of steel B microstructure differed from steels H, A and M. Significant carbide spheroidisation is apparent at grain boundaries, as well as within martensite packets, however, packet morphology with its parallel subunits is still clearly observed using light microscopy. This is most likely indicative of a higher tempering temperature for this steel, where the major effect of tempering has been to remove smaller laths and

produce coarse spheroidal Fe_3C particles within the lath packets and at grain boundaries [10]. It would be expected that the dislocation density was lower than for steels H, A and M and, combined with lower carbon concentration, would give lower hardness and strength results and higher ductility. These properties are apparent in Table 2. The general behaviour of higher tempering temperature, producing greater toughness for armour steels has also been shown in previous studies [9, 11].

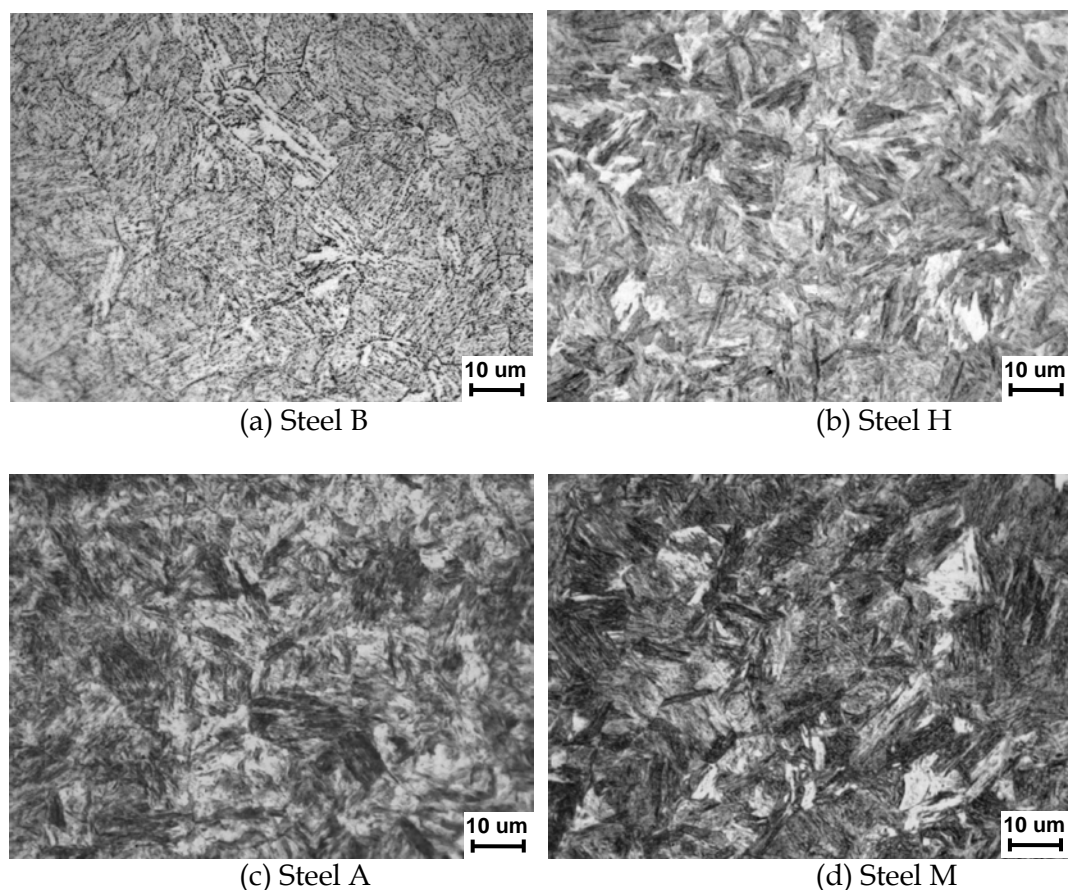

Figure 3: Microstructure of (a) steel B, (b) steel H, (c) steel A, and (d) steel M, showing tempered martensitic microstructure. Note: steel B shows a higher degree of tempering compared to the other steels..

Retained austenite was not detected in any of the 4 steels examined in this study. Retained austenite present in small levels (4-6%) within martensitic microstructures, has been shown to enhance ballistic performance due to a resistance in localised yielding of the steel at impact, by the lowering of the yield strength to tensile strength ratio [12, 13].

The microstructural analyses undertaken in this work provided limited information to help understand why the steels A and M have such a high stiffness, low bulge depth as well as high energy absorption properties in comparison with other steels tested. A number of factors could be responsible, but were not within the scope of this work. These include: (1) the role of alloying elements affecting solid-solution strengthening within steels, hence pinning dislocations; (2) inclusion size and distribution; (3) impurity atoms

and their locations, in particular at grain boundaries; (4) texture evolution and anisotropy (in particular, the influence of rolling direction) was not examined. It is known that steels M and A are cross-rolled to improve isotropy, while B and H steels are rolled in the one direction only and (5) the proportion of high-angled grain boundaries that trigger dislocation initiation in adjoining grains and therefore act as strengthening mechanisms.

3.2 EBT results: Bulge depth comparison

Figure 4 shows a comparison of the bulge depths measured for each plate material, with respect to the number of blasts. After the 1st blast, steels M, A, and H had similar deformation. Steel B produced the largest bulge depth of the 4 plates tested. After repeated blasting, steel H failed after 5 blasts and steel B was seriously damaged after 6 blasts. However, both steels M and A were intact after 7 successive blasts.

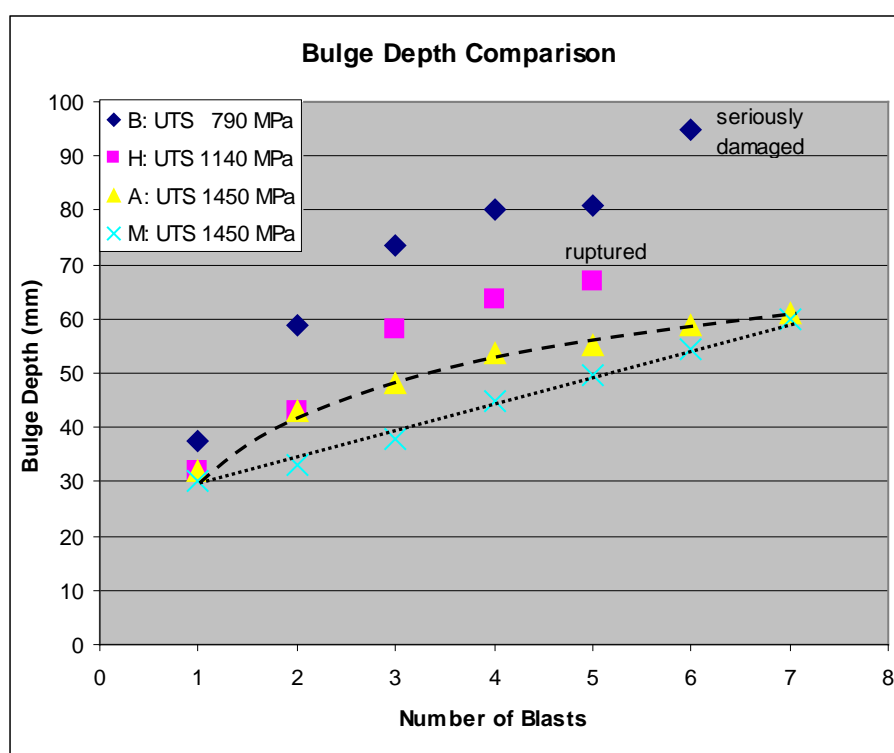

Figure 4: Bulge depth versus number of blasts for the four steel tested.

It is notable that the trend of bulge depths vs. blast no. obtained from steel M shows a steady linear increase. This signifies good toughness, strength and deformation resistance under blast loading for this material. Interestingly, the trend of bulge depth vs. blast no. for steel A follows a curve from the 2nd until the 6th blast, after which the bulge depth observed is almost identical to that of steel M. These materials have almost identical chemistry, microstructure and mechanical properties, although impact toughness is ~ 30% greater for steel M.

In contrast, steels B and H show significantly larger bulge depth increases (especially steel B) from blasts 3 to 6, with severe cracking occurring in steel H after 5 blasts. As expected, steel B gave the greatest bulge depth, due most likely to lower carbon in solid-solution, as well as greater tempering (thereby inducing lower dislocation density and spheroidic carbide precipitates (Figure 3 (a)). This results in reduced strength and hardness but increasing toughness and ductility in comparison with the other steels. Steel H showed a plateau trend with increasing blasts, until cracking occurred into the steel plate. This material possessed the lowest impact toughness of all four plate materials with 22 J at -40 °C.

A summary of the bulge depths and associated behaviours observed at the site of the brittle hard-facing weld bead during EBT are described as follows:

1. First blast

The first blast did not show any noticeable damage or difference in appearance between the four plate materials tested. Further, the bulge depths observed in all plates, with the exception of B plate (which was significantly deformed to 38 mm bulge depth), were similar (approximately 30 mm).

2. Subsequent blasts

From Figure 4 it is noteworthy that the extent of deformation is considerably less for the second and subsequent blasts than it is for the first blast. This is probably associated with work hardening of the plates. It is possible to exploit this phenomenon in future steels. For example, armour could be hardened by blasting prior to fabrication.

In line with the requirements of the EBT, blasting was repeated for each of the plates to rank the materials in order of deformation resistance and to observe any crack growth. After the 4th blast, B steel showed some minor cracking across the hard-facing weld bead and into the plate (Figure 5). The other plates had no cracks outside the weld bead.

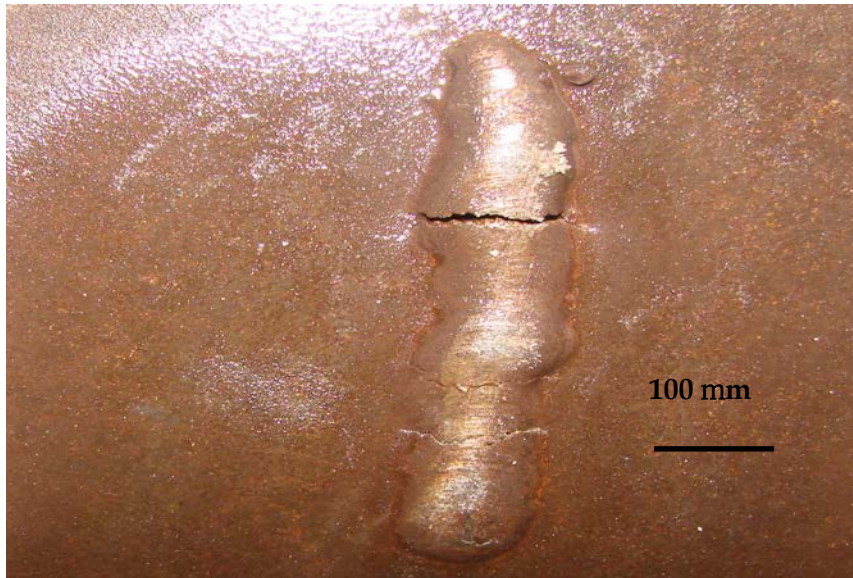

Figure 5: Minor cracked in steel B (hard facing deposit and steel HAZ) after 4th blast.

The appearance of crack starter weld beads after 6 blasts is shown for the four steels in Figure 6 . It was observed that steel A (Figure 6c) and steel M (Figure 6d) did not show any crack initiation into the plates. Furthermore, these two plates showed very similar bulge depth after 6 blasts. However, it can be seen that steels B (Figure 6a) and H (Figure 6b) developed cracking into the plate material, with steel H showing extensive cracking to have occurred from the weld bead and into the plate. Therefore, steel H was shown to produce the most brittle behaviour under blast loading. Due to the extent of cracking, bulge depth was not recorded for steel H after the 6th blast.

The lifting lug of the B steel was seriously damaged after blast 6. For this reason no further blast testing was performed. At this stage, it is concluded that B steel has good ductility but has low deformation resistance.

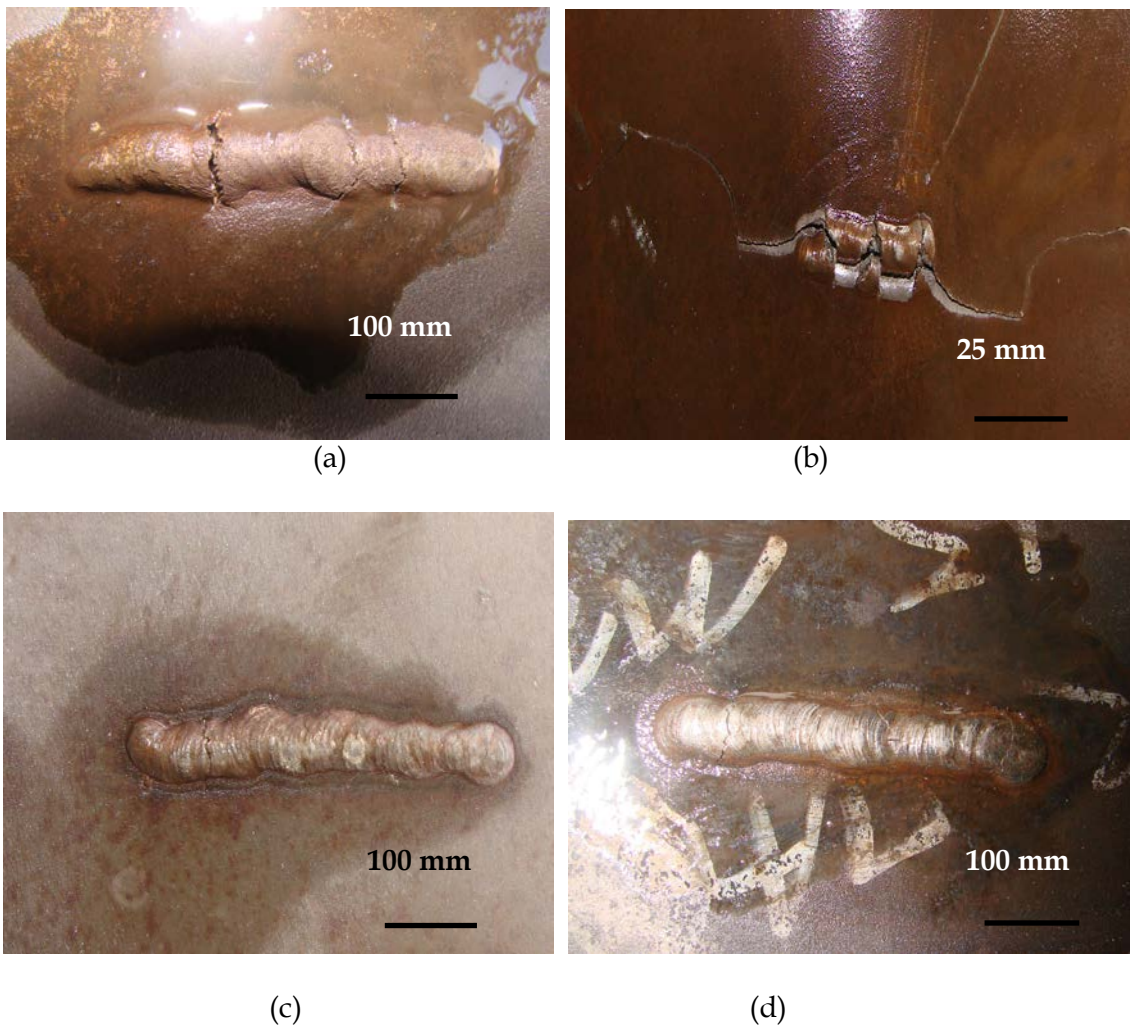

Figure 6: Surface appearance of the four plates (a) steel B, (b) steel H, (c) steel A and (d) steel M, after the 6th blast, clearly showing the brittle weld bead and any cracking that had occurred.

After the 7th blast, it was found that neither A steel or M steel showed cracking damage into the plates. It is thus concluded that these two materials have excellent properties in view of ductility, toughness and deformation resistance with respect to the EBT performed.

4. Conclusions

This work compared four commercial armour steels, possessing a range of steel chemistries and mechanical properties, with respect to their resistance to multiple blast loadings. Both toughness and deformation resistance of the steels were assessed by bulge depth measurements and cracking assessments using the EBT. A number of conclusions may be drawn from these investigations and are:

1. All steels tested were provided in the Q&T condition, possessing tempered martensitic microstructures. Steels H, A and M possessed very similar microstructures at the metallurgical levels examined in this work. Steel B has leaner carbon content and appears to have experienced a higher tempering temperature, producing good toughness and greater ductility, but less hardness.
2. Multiple blast testing showed that steel A and steel M possessed the best resistance to deformation and rupture. They are strong candidates for blast-resistive armour material. Steel M showed the best resistance in terms of bulge depth deformation and toughness. It should also be noted that Steel M possessed approximately 30% higher Charpy impact toughness than A in the as-received condition.
3. Steel B showed good rupture resistance, toughness and the highest deformation under blast loading, particularly when subjected to multiple hits. This is consistent with the hereby tempered microstructure observed for this steel.
4. Steel H showed intermediate deformation properties, placed between steel M and steel B. It was also demonstrated to be the most brittle of the four steels, withstanding only 5 blasts instead of 7, with cracking occurring in the plate material. This behaviour corresponded to the steel having the lowest Charpy V-notch impact toughness results, as well as the highest carbon content of the steels tested.
5. For all steels the greatest deformation occurred in the first blast. This suggests that blasting may have a work hardening effect that may be used , in future, to produce blast resistant steels.

5. Acknowledgements

We gratefully acknowledge the assistance of John Williams and Trevor Delaney for their hard work during the tests and Stewart Alkemade for his refereeing and correction of the paper.

6. References

- [1] G.E. Dieter, *Mechanical Metallurgy*. 1988. Singapore. McGraw-Hill.
- [2] R. Viswanathan, 'Damage Mechanisms and Life Assessment of High-Temperature', Components. 1995. USA, ASM International.
- [3] M. Acarer, B. Demir, 'An investigation of mechanical and metallurgical properties of explosive welded aluminium-dual phase steel', *Mater Lett*, vol 62(25), 2008, p4158-4160.
- [4] J. Ritter, B. Dixon, and R. Phillips, 'Assessment of Welded Steel of 690 MPa. Yield Stress for the Type 471 Submarine', 1990, MRL Technical Report MRL-TR-90-1.
- [5] C. Choi and B. Dixon, 'Shock toughness and deformation resistance of candidate armour steels', DSTO-CR-2010-0202, DSTO technical report, 2010.
- [6] C. Choi, M. Callaghan and B. Dixon, Effect of Explosion Bulge Test Parameters on the Measurement of Toughness and Deformation Resistance for Steel, DSTO technical report, 2012
- [7] NAVSHIPS 0900-005-500 Revision 1, 1965
- [8] A. Marc. Meyers, Chapter 9-2, 'Dynamic Behaviour of materials', 1994, John Willey & Sons, Inc, ISBN-041-58262-X.
- [9] J. Prifti, R. Squillacioti, and R. Cellitti, 'Improved rolled homogeneous armor (IRHA) steel through higher hardness'. 1997. U. S. Army Research Laboratory: Aberdeen, no: ARL-TR-1347, p49.
- [10] G. Krauss, *Steels: Processing, Structure, and Performance*. 2005. USA, ASM International.
- [11] K. Maweja and W. Stumpf, 'The design of advanced performance high strength low-carbon martensitic armour steels: Part 1. Mechanical property considerations', *Materials Science and Engineering: A*, 2008. 485(1-2): p140-153.
- [12] K. Maweja and W. Stumpf, 'The design of advanced performance high strength low-carbon martensitic armour steels. Microstructural considerations', *Materials Science and Engineering A*, 2008. 480(1-2), p160-166.
- [13] P.W. Cooper, 'Explosives Engineering', Wiley-VCH, Inc, 1996.

DEFENCE SCIENCE AND TECHNOLOGY ORGANISATION DOCUMENT CONTROL DATA		1. PRIVACY MARKING/CAVEAT (OF DOCUMENT)			
		2. TITLE Blast Performance of Four Armour Materials		3. SECURITY CLASSIFICATION (FOR UNCLASSIFIED REPORTS THAT ARE LIMITED RELEASE USE (L) NEXT TO DOCUMENT CLASSIFICATION) Document (U) Title (U) Abstract (U)	
4. AUTHOR(S) C. Choi, M. Callaghan and B. Dixon		5. CORPORATE AUTHOR DSTO Defence Science and Technology Organisation PO Box 1500 Edinburgh South Australia 5111 Australia			
6a. DSTO NUMBER DSTO-TR-2888	6b. AR NUMBER AR-015-705	6c. TYPE OF REPORT Technical Report	7. DOCUMENT DATE August 2013		
8. FILE NUMBER 2012-112-3415	9. TASK NUMBER ARM 07/132	10. TASK SPONSOR Army	11. NO. OF PAGES 12	12. NO. OF REFERENCES 13	
13. DSTO Publications Repository http://dspace.dsto.defence.gov.au/dspace/		14. RELEASE AUTHORITY Chief, Land Division			
15. SECONDARY RELEASE STATEMENT OF THIS DOCUMENT <i>Approved for Public Release</i> OVERSEAS ENQUIRIES OUTSIDE STATED LIMITATIONS SHOULD BE REFERRED THROUGH DOCUMENT EXCHANGE, PO BOX 1500, EDINBURGH, SA 5111					
16. DELIBERATE ANNOUNCEMENT No Limitations					
17. CITATION IN OTHER DOCUMENTS Yes					
18. DSTO RESEARCH LIBRARY THESAURUS blast, armour, bulge depth, comparison					
19. ABSTRACT This investigation compared four conventional vehicle armour materials for performance under blast loading. The parameters measured were resistance to deformation, mechanical toughness and metallurgical microstructure. It was found that two of these, the M steel and A steel, showed the least deformation and M steel showed better shock energy absorption. B steel had high toughness but showed significant deformation under blast loading; particularly when subjected to multiple hits. H steel showed intermediate properties between M steel and B steel. It is concluded that M and A steels provide the best performance for use on vehicles that may be subjected to explosive charges.					