

# ILLUSTRATED TAXONOMIC KEYS TO GENERA AND SPECIES OF MOSQUITO LARVAE OF KOREA

## PART II



DEPARTMENT OF THE ARMY  
5TH PREVENTIVE MEDICINE UNIT  
18TH MEDICAL COMMAND  
APO SAN FRANCISCO 96301

BY  
KWAN WOO LEE AND THOMAS ZORKA

AUGUST 1987



# Report Documentation Page

*Form Approved*  
*OMB No. 0704-0188*

Public reporting burden for the collection of information is estimated to average 1 hour per response, including the time for reviewing instructions, searching existing data sources, gathering and maintaining the data needed, and completing and reviewing the collection of information. Send comments regarding this burden estimate or any other aspect of this collection of information, including suggestions for reducing this burden, to Washington Headquarters Services, Directorate for Information Operations and Reports, 1215 Jefferson Davis Highway, Suite 1204, Arlington VA 22202-4302. Respondents should be aware that notwithstanding any other provision of law, no person shall be subject to a penalty for failing to comply with a collection of information if it does not display a currently valid OMB control number.

1. REPORT DATE <b>AUG 1987</b>	2. REPORT TYPE	3. DATES COVERED <b>00-00-1987 to 00-00-1987</b>			
4. TITLE AND SUBTITLE <b>Illustrated Taxonomic Keys to Genera and Species of Mosquito Larvae of Korea. Part II</b>		5a. CONTRACT NUMBER			
		5b. GRANT NUMBER			
		5c. PROGRAM ELEMENT NUMBER			
6. AUTHOR(S)		5d. PROJECT NUMBER			
		5e. TASK NUMBER			
		5f. WORK UNIT NUMBER			
7. PERFORMING ORGANIZATION NAME(S) AND ADDRESS(ES) <b>Department of the Army, 5th Preventive Medicine Unit, 18th Army Medical Command, APO, AP, 96301</b>		8. PERFORMING ORGANIZATION REPORT NUMBER			
9. SPONSORING/MONITORING AGENCY NAME(S) AND ADDRESS(ES)		10. SPONSOR/MONITOR'S ACRONYM(S)			
		11. SPONSOR/MONITOR'S REPORT NUMBER(S)			
12. DISTRIBUTION/AVAILABILITY STATEMENT <b>Approved for public release; distribution unlimited</b>					
13. SUPPLEMENTARY NOTES					
14. ABSTRACT					
15. SUBJECT TERMS					
16. SECURITY CLASSIFICATION OF:			17. LIMITATION OF ABSTRACT <b>Same as Report (SAR)</b>	18. NUMBER OF PAGES <b>30</b>	19a. NAME OF RESPONSIBLE PERSON
a. REPORT <b>unclassified</b>	b. ABSTRACT <b>unclassified</b>	c. THIS PAGE <b>unclassified</b>			

ILLUSTRATED TAXONOMIC KEYS TO GENERA AND SPECIES OF  
MOSQUITO LARVAE OF KOREA

PART II

BY

KWAN WOO LEE AND THOMAS ZORKA

AUGUST 1987

DEPARTMENT OF THE ARMY  
5TH PREVENTIVE MEDICINE UNIT  
18TH MEDICAL COMMAND  
APO SAN FRANCISCO 96301

TABLE OF CONTENTS

List of Species Included. . . . .	iii
Preface. . . . .	1
Morphology of <i>Anopheline</i> and <i>Culicine</i> Mosquito Larva . . . . .	2
Key to the Genera of <i>Culicidae</i> . . . . .	5-9
Genus <i>Anopheles</i> . . . . .	5
Genus <i>Toxorhynchites</i> . . . . .	5
Genus <i>Tripterooides</i> . . . . .	6
Genus <i>Mansonia</i> . . . . .	7
Genus <i>Armigeres</i> . . . . .	8
Genus <i>Culex</i> . . . . .	8
Genus <i>Culiseta</i> . . . . .	8-9
Genus <i>Aedes</i> . . . . .	8
Genus <i>Heizmannia</i> . . . . .	8
Key to the Species of <i>Anopheles</i> . . . . .	10-11
Key to the Species of <i>Culex</i> . . . . .	12-19
Key to the Species of <i>Aedes</i> and <i>Heizmannia</i> . . . . .	20-26

LIST OF SPECIES INCLUDED

1. <i>Anopheles</i> ( <i>Anopheles</i> ) <i>sinensis</i> Wiedemann . . . . .	11
2. <i>Anopheles</i> ( <i>Anopheles</i> ) <i>sineroides</i> Yamada . . . . .	11
3. <i>Anopheles</i> ( <i>Anopheles</i> ) <i>koreicus</i> Yamada and Watanabe . . . . .	11
4. <i>Anopheles</i> ( <i>Anopheles</i> ) <i>yatsushiroensis</i> Miyazaki . . . . .	11
5. <i>Anopheles</i> ( <i>Anopheles</i> ) <i>lindesayi japonicus</i> Yamada . . . . .	10
6. <i>Anopheles</i> ( <i>Anopheles</i> ) <i>pullus</i> M. Yamada . . . . .	11
7. <i>Anopheles</i> ( <i>Anopheles</i> ) <i>lesteri</i> Baisas and Hu . . . . .	11
8. <i>Culex</i> ( <i>Eumelanomyia</i> ) <i>hayashii hayashii</i> Yamada . . . . .	13
9. <i>Culex</i> ( <i>Neoculex</i> ) <i>rubensis</i> Sasa and Takahasi . . . . .	13
10. <i>Culex</i> ( <i>Lutzia</i> ) <i>fuscans</i> Wiedemann . . . . .	12
11. <i>Culex</i> ( <i>Lutzia</i> ) <i>halifaxii</i> Theobald . . . . .	12
12. <i>Culex</i> ( <i>Culiciomyia</i> ) <i>kyotoensis</i> Yamaguti and La Casse . . . . .	13
13. <i>Culex</i> ( <i>Culiciomyia</i> ) <i>sasai</i> Kano, Nitahara and Awaya . . . . .	13
14. <i>Culex</i> ( <i>Culex</i> ) <i>bitaeniorhynchus</i> Giles . . . . .	16
15. <i>Culex</i> ( <i>Culex</i> ) <i>sinensis</i> Theobald . . . . .	16
16. <i>Culex</i> ( <i>Culex</i> ) <i>whitmorei</i> (Giles) . . . . .	17
17. <i>Culex</i> ( <i>Culex</i> ) <i>orientalis</i> Edwards . . . . .	19
18. <i>Culex</i> ( <i>Culex</i> ) <i>mimeticus</i> Noè . . . . .	19
19. <i>Culex</i> ( <i>Culex</i> ) <i>jacksoni</i> Edwards . . . . .	18
20. <i>Culex</i> ( <i>Culex</i> ) <i>tritaeniorhynchus</i> Giles . . . . .	18
21. <i>Culex</i> ( <i>Culex</i> ) <i>pseudovishnui</i> Colless . . . . .	17
22. <i>Culex</i> ( <i>Culex</i> ) <i>sitiens</i> Wiedemann . . . . .	17
23. <i>Culex</i> ( <i>Culex</i> ) <i>vagans</i> Wiedemann . . . . .	15
24. <i>Culex</i> ( <i>Culex</i> ) <i>pipiens pallens</i> Coquillett . . . . .	15
25. <i>Culex</i> ( <i>Culex</i> ) <i>pipiens quinquefasciatus</i> Say . . . . .	15
26. <i>Culex</i> ( <i>Barraudius</i> ) <i>inatomi</i> Kamimura and Wada . . . . .	14
27. <i>Aedes</i> ( <i>Stegomyia</i> ) <i>albopictus</i> (Skuse) . . . . .	21
28. <i>Aedes</i> ( <i>Stegomyia</i> ) <i>chemulpoensis</i> Yamada . . . . .	21
29. <i>Aedes</i> ( <i>Stegomyia</i> ) <i>flavopictus flavopictus</i> Yamada . . . . .	21
30. <i>Aedes</i> ( <i>Stegomyia</i> ) <i>galloisi</i> Yamada . . . . .	21
31. <i>Aedes</i> ( <i>Finlaya</i> ) <i>nipponicus</i> La Casse et Yamaguti . . . . .	22
32. <i>Aedes</i> ( <i>Finlaya</i> ) <i>oreophilus</i> (Edwards) . . . . .	25
33. <i>Aedes</i> ( <i>Finlaya</i> ) <i>hatorii</i> Yamada . . . . .	23
34. <i>Aedes</i> ( <i>Finlaya</i> ) <i>japonicus japonicus</i> (Theobald) . . . . .	26
35. <i>Aedes</i> ( <i>Finlaya</i> ) <i>koreicus</i> (Edwards) . . . . .	26
36. <i>Aedes</i> ( <i>Finlaya</i> ) <i>togoi</i> (Theobald) . . . . .	25
37. <i>Aedes</i> ( <i>Finlaya</i> ) <i>seoulensis</i> Yamada . . . . .	24
38. <i>Aedes</i> ( <i>Finlaya</i> ) <i>alektorovi</i> Stackelberg . . . . .	24
39. <i>Aedes</i> ( <i>Aedimorphus</i> ) <i>vexans nipponii</i> (Theobald) . . . . .	23
40. <i>Aedes</i> ( <i>Aedimorphus</i> ) <i>alboscuteclatus</i> (Theobald) . . . . .	23
41. <i>Aedes</i> ( <i>Ochlerotatus</i> ) <i>dorsalis</i> (Meigen) . . . . .	25
42. <i>Aedes</i> ( <i>Neomelaniconion</i> ) <i>lineatopennis</i> (Ludlow) . . . . .	23
43. <i>Aedes</i> ( <i>Aedes</i> ) <i>escensis</i> Yamada . . . . .	22
44. <i>Armigeres</i> ( <i>Armigeres</i> ) <i>subalbatus</i> (Coquillett) . . . . .	8
45. <i>Mansonia</i> ( <i>Mansonioides</i> ) <i>uniformis</i> (Theobald) . . . . .	7
46. <i>Mansonia</i> ( <i>Coquillettia</i> ) <i>ochracea</i> (Theobald) . . . . .	7
47. <i>Heizmannia</i> <i>lii</i> Wu . . . . .	25
48. <i>Tripteroides</i> ( <i>Tripteroides</i> ) <i>bambusa bambusa</i> (Yamada) . . . . .	6
49. <i>Culiseta</i> ( <i>Culiseta</i> ) <i>bergrothi</i> (Edwards) . . . . .	9
50. <i>Culiseta</i> ( <i>Culisella</i> ) <i>nipponica</i> La Casse and Yamaguti . . . . .	9
51. <i>Toxorhynchites</i> ( <i>Toxorhynchites</i> ) <i>christophi</i> (Portschinsky) . . . . .	5

## PREFACE

Lee and Lien's (WHO/VBC/1970) "PICTORIAL KEYS TO THE MOSQUITOES OF KOREA" has been utilized for more than 15 years as the most comprehensive taxonomic manual for identification of the non-anopheline mosquitoes of Korea. During this period many species have been recorded as new to Korea. However, much of this new taxonomic information has been distributed in a number of scientific publications. This work attempts to combine this information into a single document, as well as synthesize revised taxonomic synonyms of species occurring in Korea. Based on the available publications, the total number of mosquitoes recorded in Korea is now 51 species representing 9 genera. At present, the 5th Preventive Medicine Unit, U.S. Army is continuing its mosquito surveillance program on the taxonomy, biology and distribution of the mosquito fauna. As collections of specimens continue, there is a possibility that additional species will be found in Korea.

The preparation of these new illustrated keys is part of this ongoing study. An attempt has been made to produce a key as simple and accurate as possible. The larval characters, except some species of anopheline mosquitoes, are so clear that they are much more important and useful for identification of mosquito species. The illustrations, to include key characteristics, were selected from a composite of several specimens representing all species listed. We hope this publication will provide useful information for all army and civilian entomologist, including pest control operators.

The authors wish to express their sincere thanks to Lieutenant Colonel Ricardo Davila, Commander, and Major Anthony C. Aiken, Executive Officer, 5th Preventive Medicine Unit(5th PMU), U.S. Army, for their support, and also to Captain Schenck, John L., Jr., Entomologist, 5th PMU, for his editorial review of the manuscript.

FIGURES 1-4. FOURTH INSTAR LARVA OF ANOPHELINE MOSQUITOES

1. HEAD: dorsal-left, ventral-right
2. THORAX: dorsal-left, ventral-right
3. ABDOMINAL SEGMENTS(I-VI): dorsal-left, ventral-right
4. TERMINAL SEGMENT(VII-X) OF ABDOMEN

FIGURES 5-8. FOURTH INSTAR LARVA OF CULICINE MOSQUITOES

5. HEAD: dorsal-left, ventral-right
6. THORAX: dorsal-left, ventral-right
7. ABDOMINAL SEGMENT(I-VI): dorsal-left, ventral-right
8. TERMINAL SEGMENT(VII-X) OF ABDOMEN

ABBREVIATION:

A =Antenna	PH =Palmate hair
C =Clypeus	PT =Pecten tooth
CE =Compound eye	S =Siphon
CS =Comb scale	SL =Saddle
PC =Pecten	SM =Stemma
G =Anal gills	T =Metathorax
M =Mesothorax	TP =Tergal plate
MP =Mentum plate	1-MX =Cardinal seta
P =Prothorax	

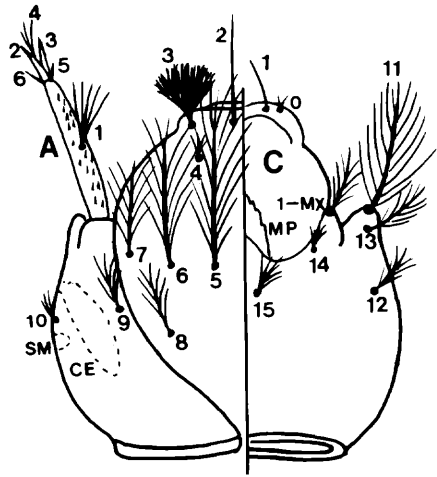

FIG. 1

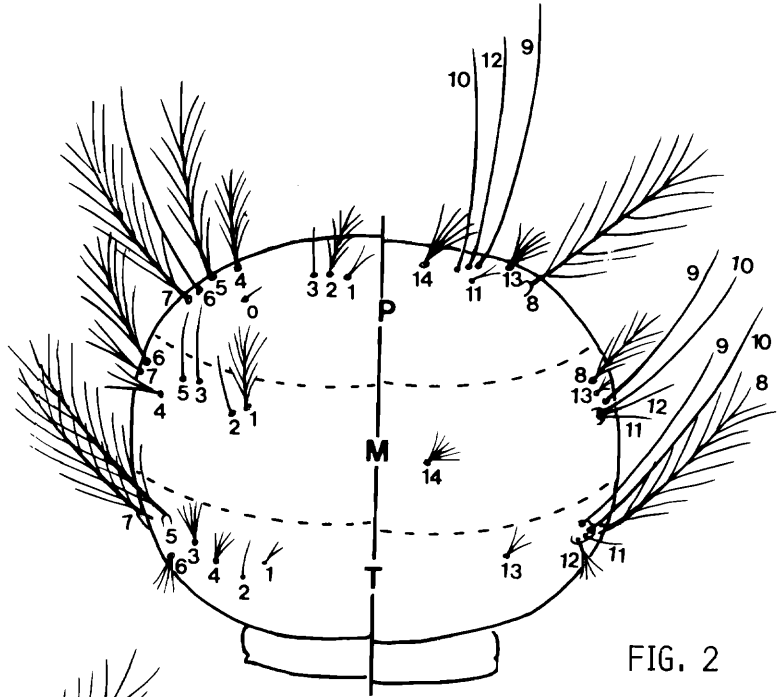

FIG. 2

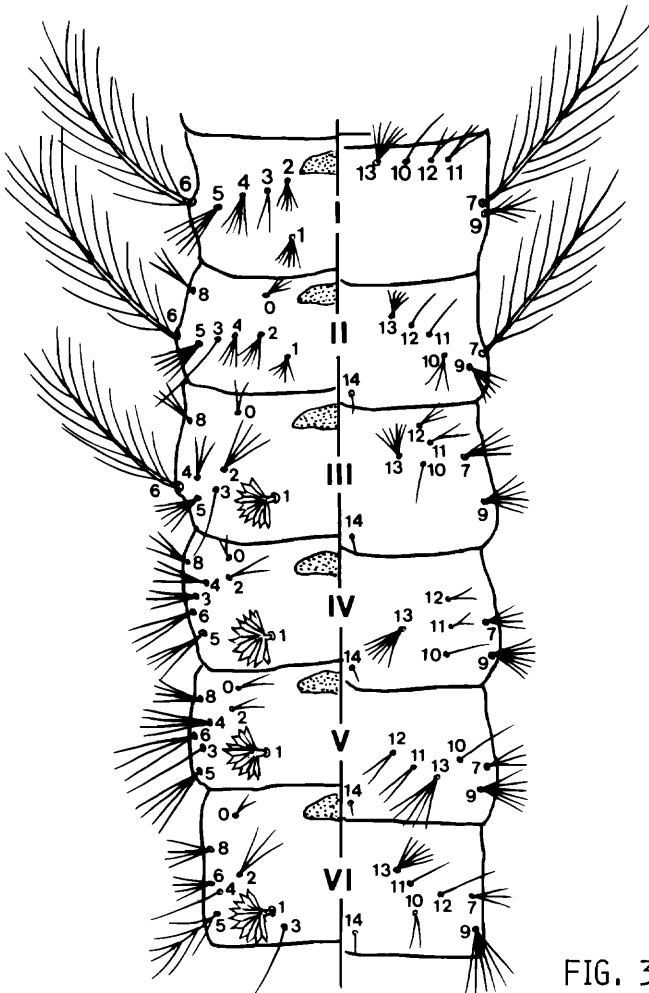

FIG. 3

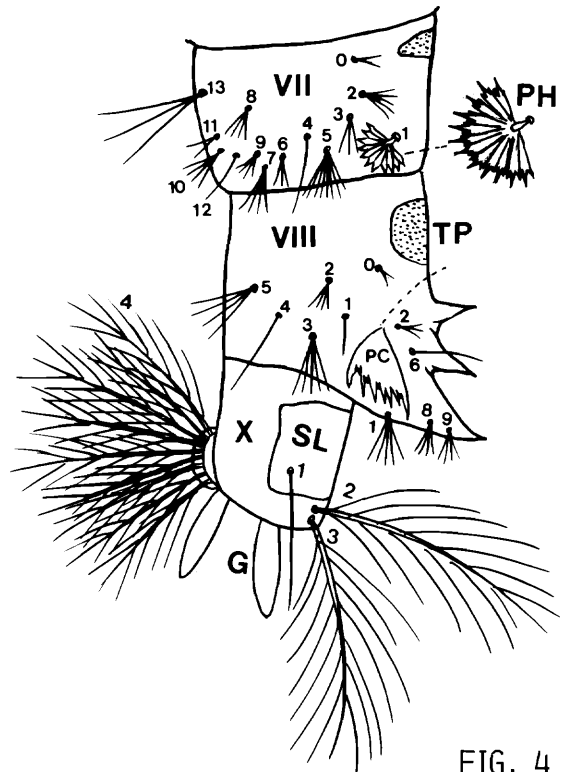

FIG. 4



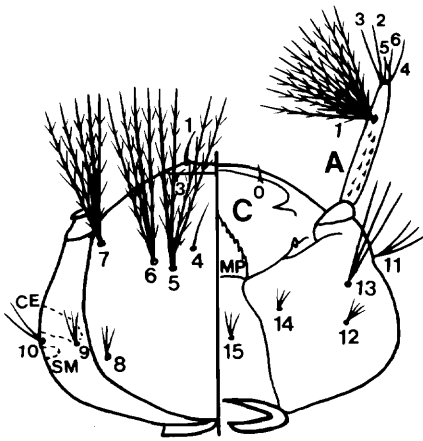

FIG. 5

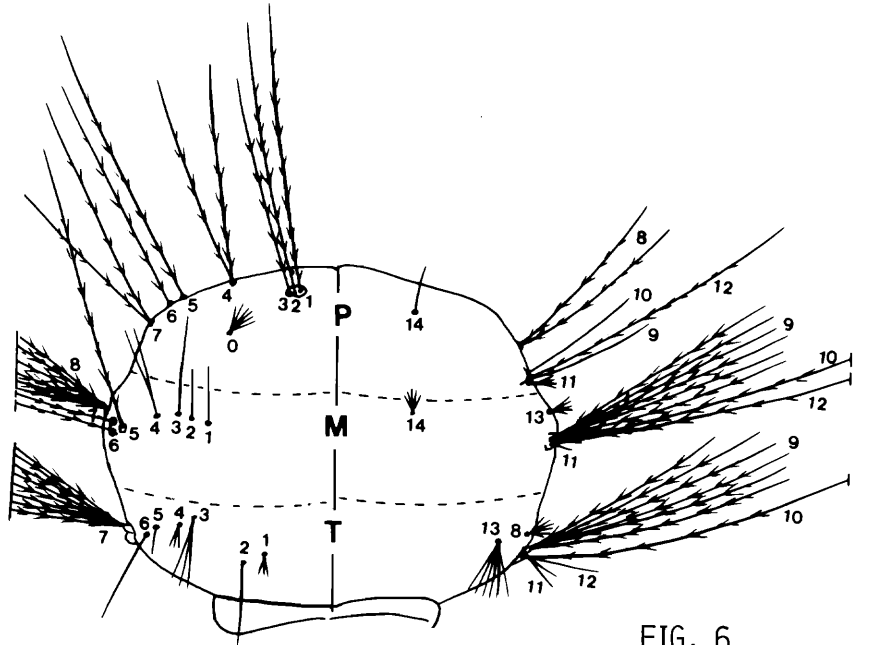

FIG. 6

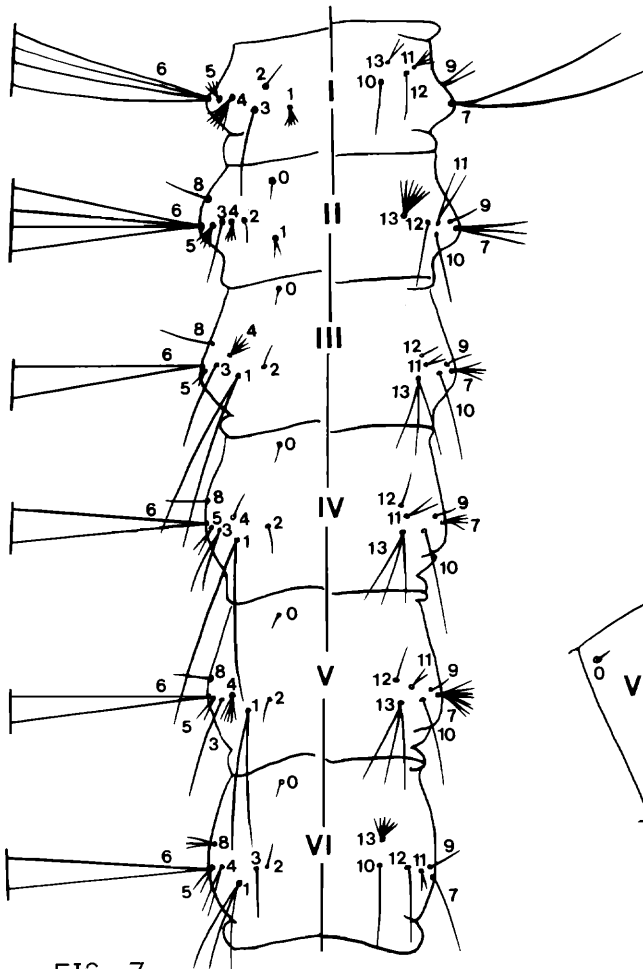

FIG. 7

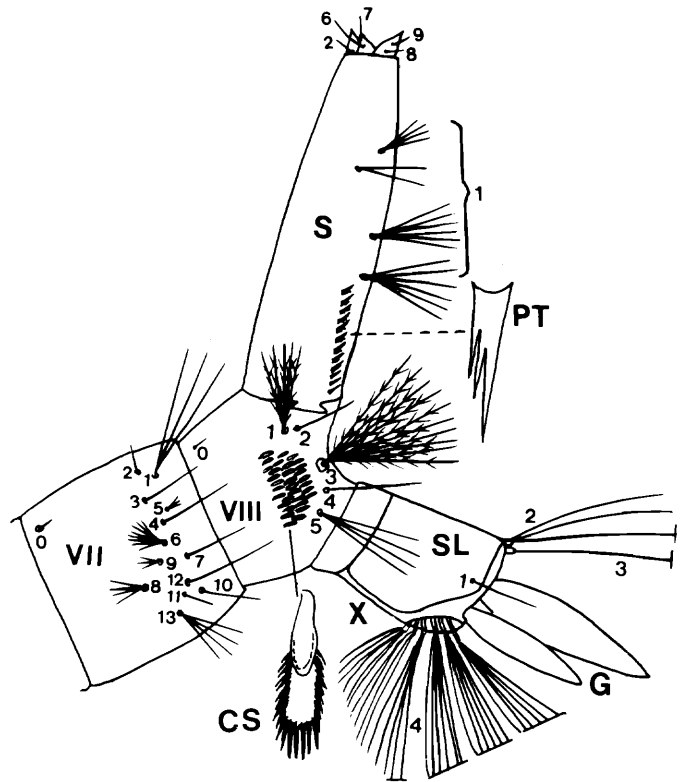

FIG. 8

KEY TO THE GENERA OF CULICIDAE LARVAE

1. Palmate hairs present on some abdominal segments; air tube absent (Fig. 9) . . . . . *Anopheles*  
 Palmate hairs absent on abdominal segments; air tube present (Fig. 10) . . . . . 2

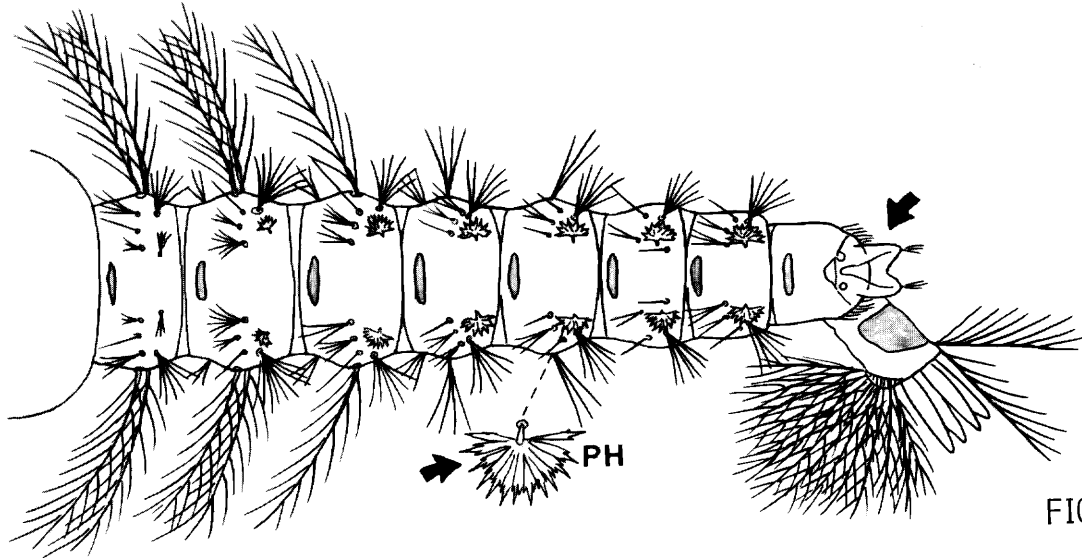

FIG. 9

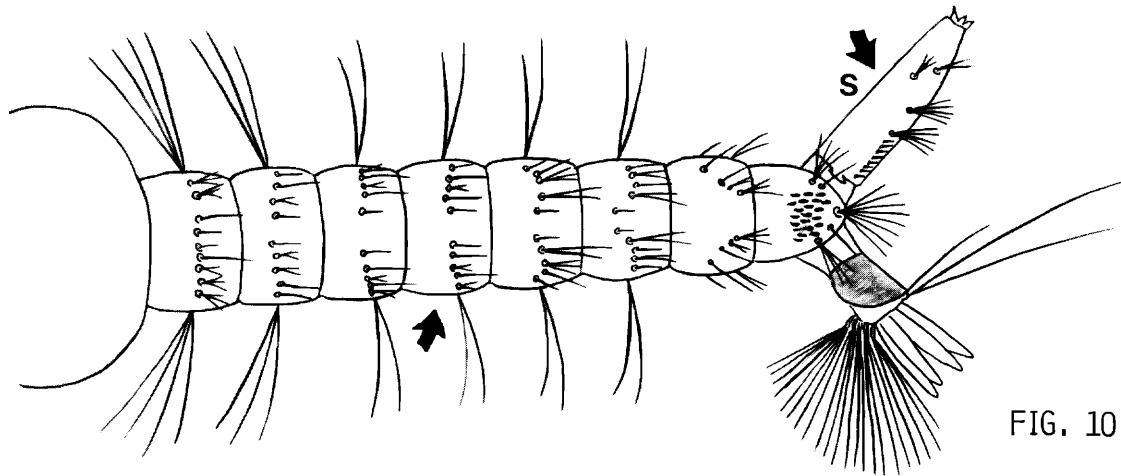

FIG. 10

2. Eighth abdominal segment without comb, but with lateral chitinized plate on each side carrying two strong bristles and some small hairs (Fig. 11) . . . . . *Toxorhynchites christophi*

- Eighth abdominal segment with comb, and without lateral chitinized plates (Fig. 12) . . . . . 3

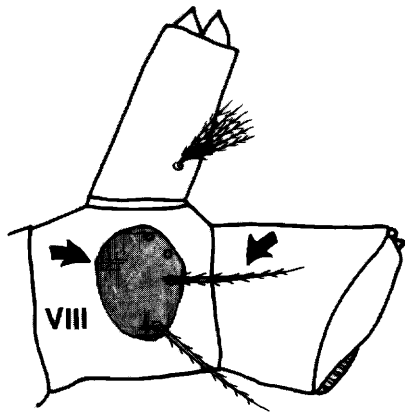

FIG. 11

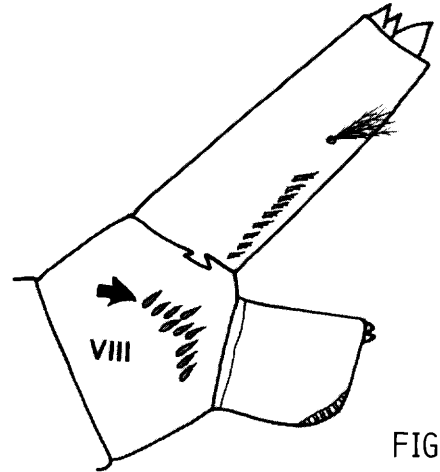

FIG. 12

3. Ventral brush of anal segment represented by a single pair of hairs (Fig. 13); thoracic hair 7-T modified into a long spine (Fig. 14). . . . . *Tripterooides T. bambusa bambusa*

Ventral brush of anal segment of more than 8 separate hairs (Fig. 15); thoracic hair 7-T not modified into a long spine (Fig. 16). . . . . 4

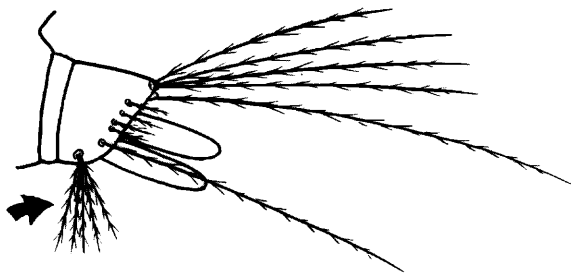

FIG. 13

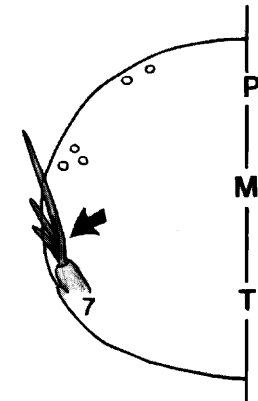

FIG. 14

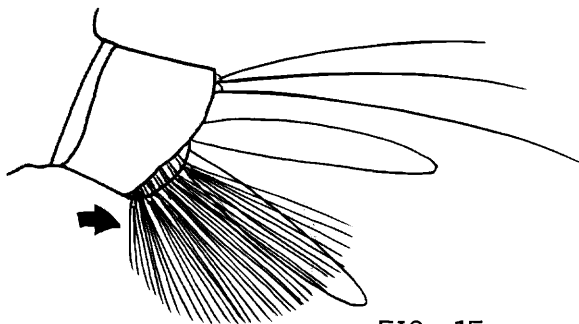

FIG. 15

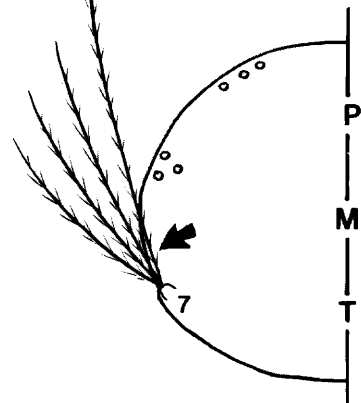

FIG. 16

4. Siphon valves with chitinous hooks (Fig. 17). . . . . *Mansonia* see 5  
 Siphon valves without hooks (Fig. 18). . . . . 6

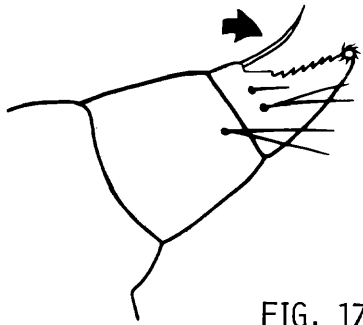

FIG. 17

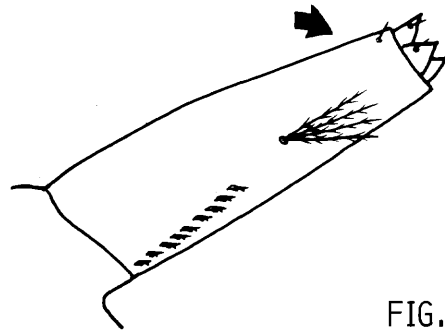

FIG. 18

5. Flaggellar segment of antenna very long and flexible (Fig. 19); comb scales 5-10, with apex pectinated (Fig. 20). . . . . *M. (Cosquillettidia) ochracea*  
 Flaggellar segment of antenna short and rigid (Fig. 21); comb scales 1-3, with apex rounded (Fig. 22). . . . . *M. (Mansonioides) uniformis*

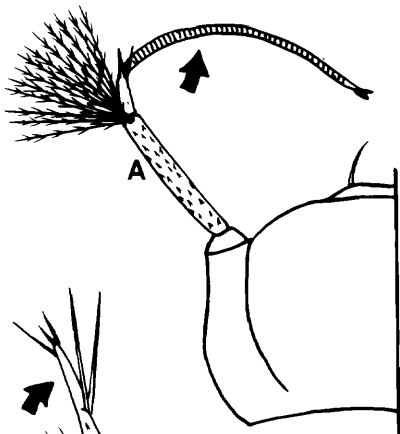

FIG. 19

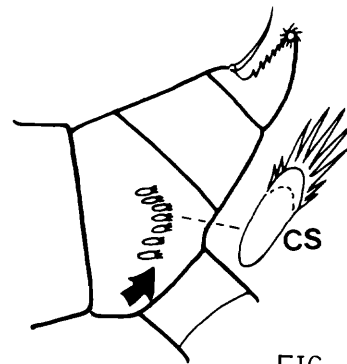

FIG. 20

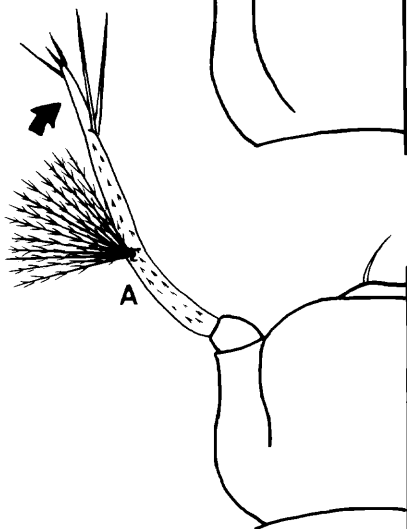

FIG. 21

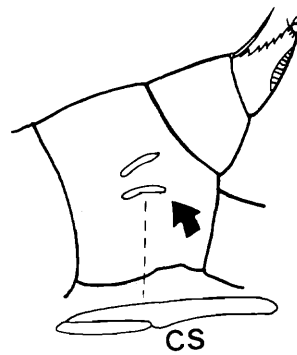

FIG. 22

6. Siphon without pecten (Fig. 23) . . . . . *Armigeres*  
*Ar. subalbatus*  
 Siphon with pecten (Fig. 24) . . . . . 7

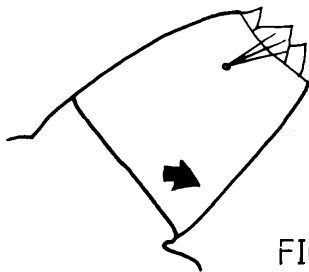

FIG. 23

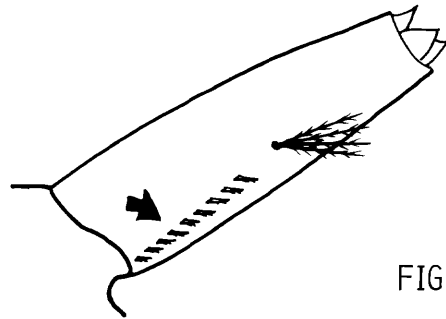

FIG. 24

7. Siphon with more than three pairs of subventral hair tufts (Fig. 25) . . . . . *Culex*  
 Siphon with only one pair of subventral hair tufts (Fig. 26) . . . . . 8

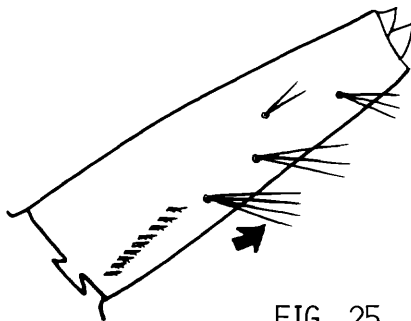

FIG. 25

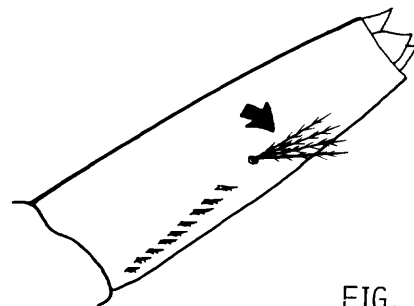

FIG. 26

8. Hair tufts on siphon arising very near base of siphon (Fig. 27) . . . . . *Culiseta* see 9  
 Hair tufts on siphon arising in middle part of siphon (Fig. 28) . . . . . *Aedes & Heizmannia*

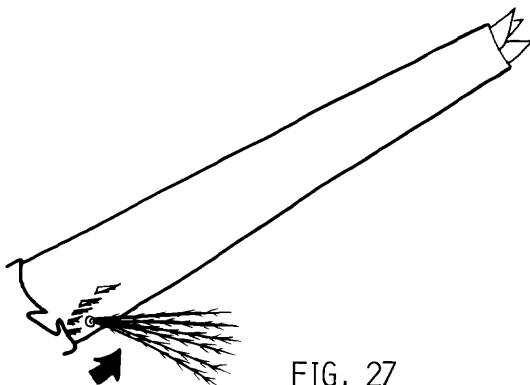

FIG. 27

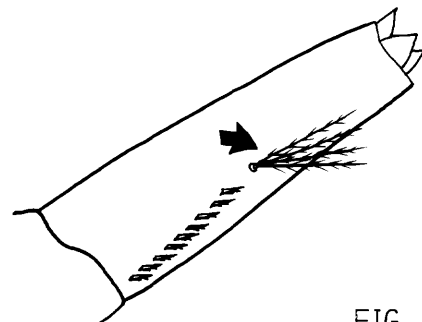

FIG. 28

9. Pecten followed by a row of numerous simple hairs (Fig. 29). . . . . *C. (Culiseta) bergrothi*  
 Pecten not followed by such hairs (Fig. 30). . . *C. (Culisella) nipponica*

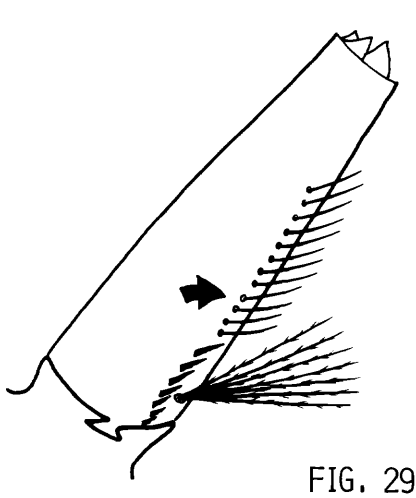

FIG. 29

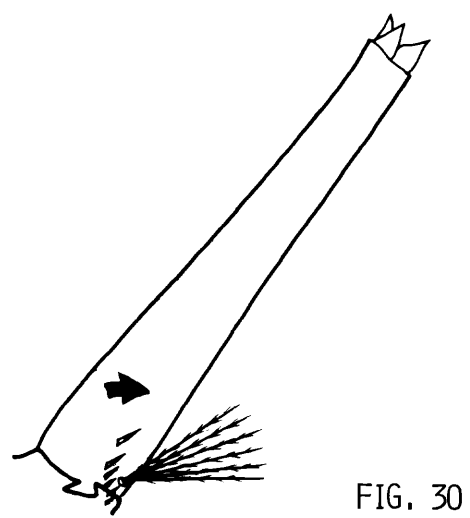

FIG. 30

KEY TO THE SPECIES OF ANOPHELES LARVAE

1. Head hair 3-C single (Fig. 31); thoracic hair 1-P plumose (Fig. 32) . . . . . *An. lindesayi japonicus*  
 Head hair 3-C multiple branches (Fig. 33); thoracic hair 1-P single or 2-4 branches (Fig. 34) . . . . . 2

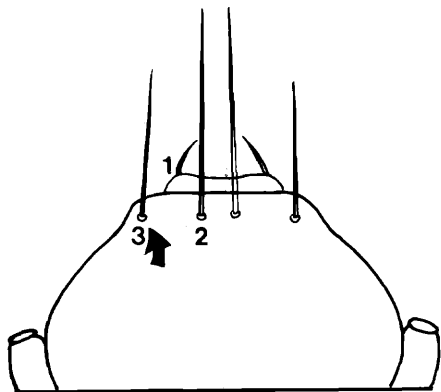

FIG. 31

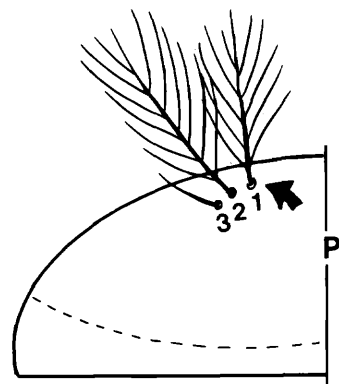

FIG. 32

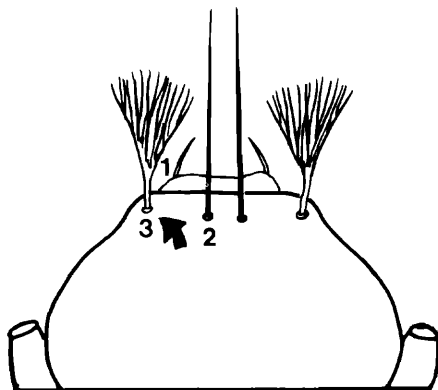

FIG. 33

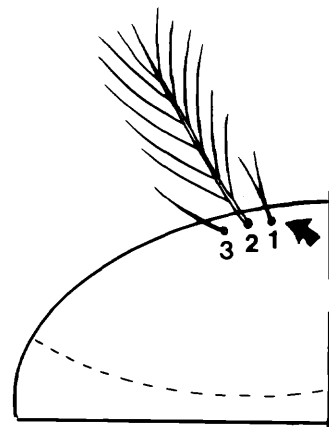

FIG. 34

2. Head hair 3-C with 3-8 branches (Fig. 35). . . . . *An. koreicus*  
 Head hair 3-C with over 10 branches (Fig. 36). . . . . 3

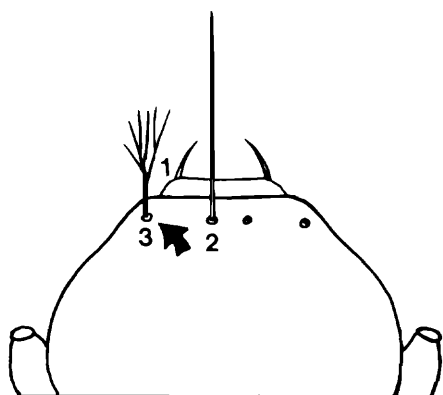

FIG.-35

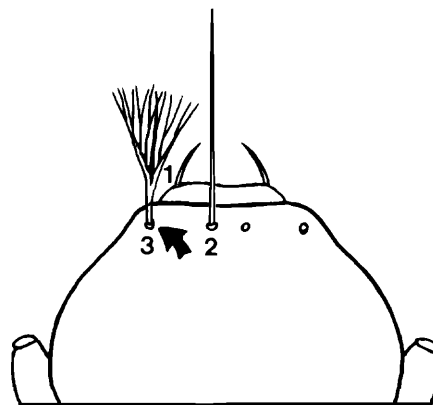

FIG. 36

3. Head hair 3-C with 10-30 branches; antennal hair 1-A about as long as 1/4-1/3 of the antennal shaft, positioned near base of antenna (Fig. 37). . . . . *An. sineroides*

- Head hair 3-C with 30-60 branched; antennal hair 1-A about as long as 1/2 of the antennal shaft, positioned at middle of antenna (Fig. 38). . . . . *An. sinensis*  
 . . . . . *An. yatsushiroensis*  
 . . . . . *An. pullus*  
 . . . . . *An. lesteri*

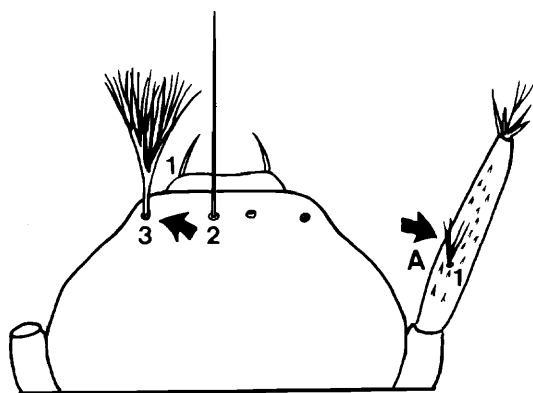

FIG. 37

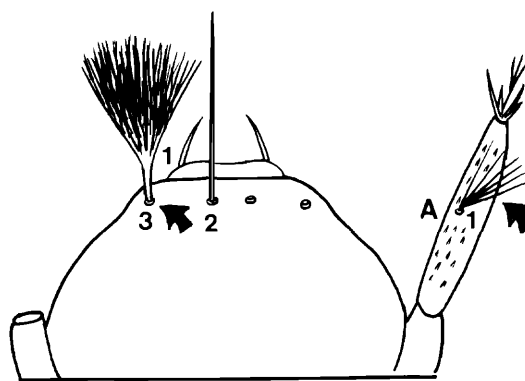

FIG. 38



## KEY TO THE SPECIES OF CULEX LARVAE

1. Siphon as long as saddle; pecten and ventral hairs extending to nearly apex of siphon  
 (Fig. 39) . . . . . *Cu. halifaxii*  
*Cu. fuscans*

- Siphon at least twice as long as saddle;  
 pecten confined to basal half of siphon  
 (Fig. 40) . . . . . 2

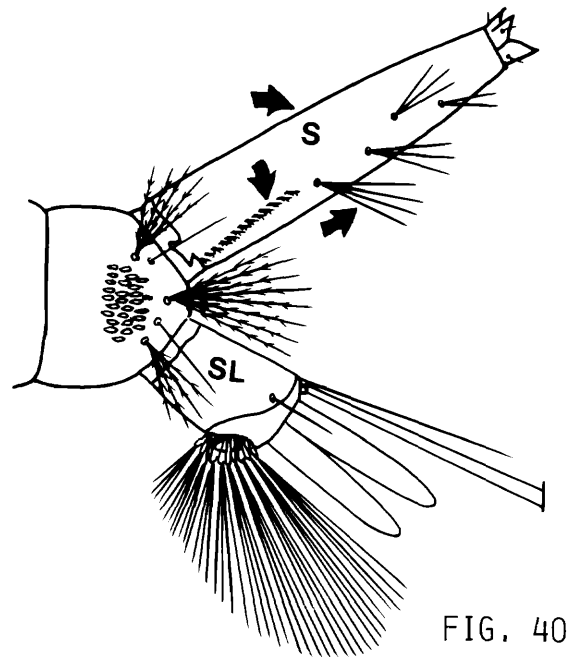
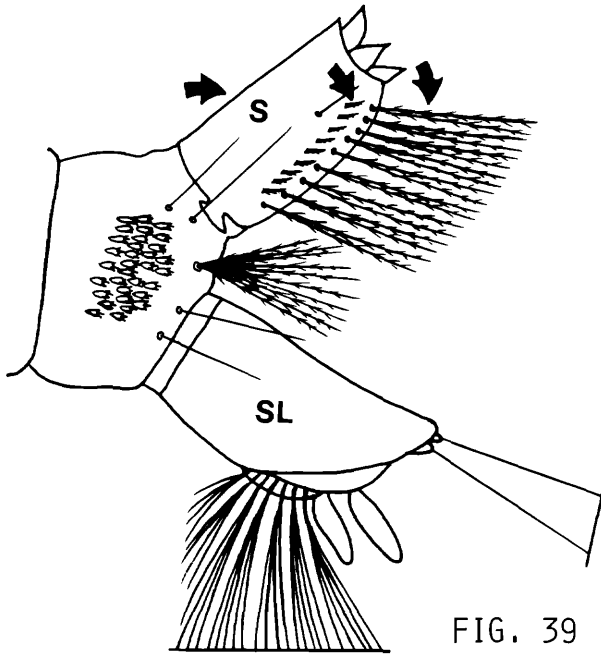

2. Thoracic hair 3-P slender, single or branched,  
 and shorter than 1,2-P (Fig. 41) . . . . . 3  
 Thoracic hair 3-P stout and as long as 1,2-P  
 (Fig. 42) . . . . . 4

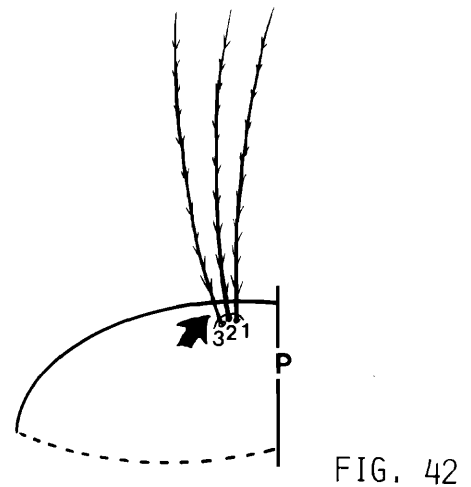
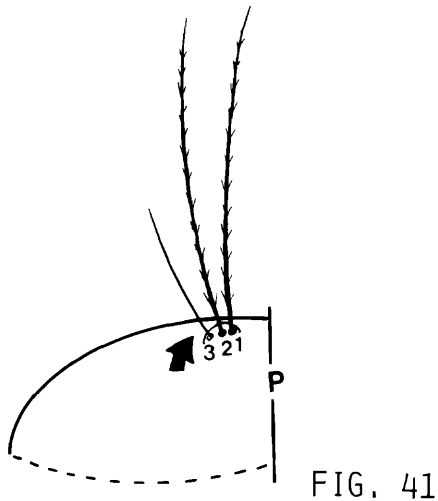

3. Head hairs 5,6-C less developed and shorter than 7-C (Fig. 43) . . . . . *Cu. hayashii hayashii*  
 Head hairs 5,6-C as developed and as long as 7-C (Fig. 44) . . . . . *Cu. rubensis*

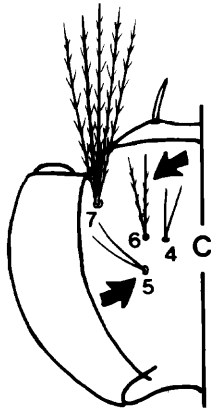

FIG. 43

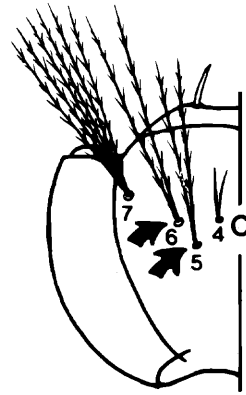

FIG. 44

4. Thoracic hairs 1,3-P bibranched (Fig. 45) . . . . . 5  
 Thoracic hairs 1,3-P single (Fig. 46) . . . . . 6

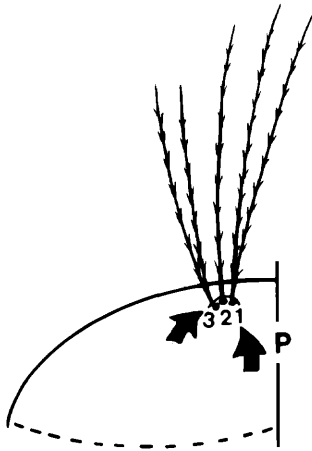

FIG. 45

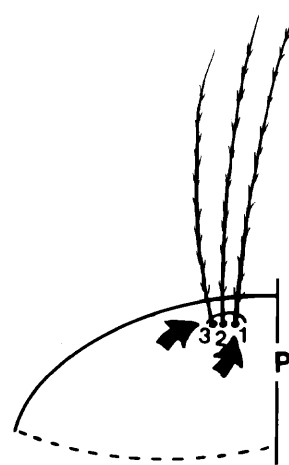

FIG. 46

5. Siphon long, at least 6 times longer than its basal width; subventral hairs weak, shorter than siphon width, usually single or bibranched; saddle not emarginated (Fig. 47) . . . . . *Cu. kyotoensis*  
 Siphon shorter, approximately 5 times its basal width; subventral hairs moderately strong, about length of siphon width, usually with 3 or more branches; saddle emarginated near seta 4-X (Fig. 48) . . . . . *Cu. sasai*

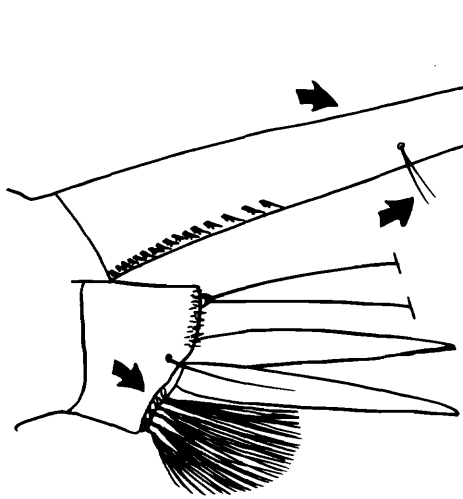

FIG. 47

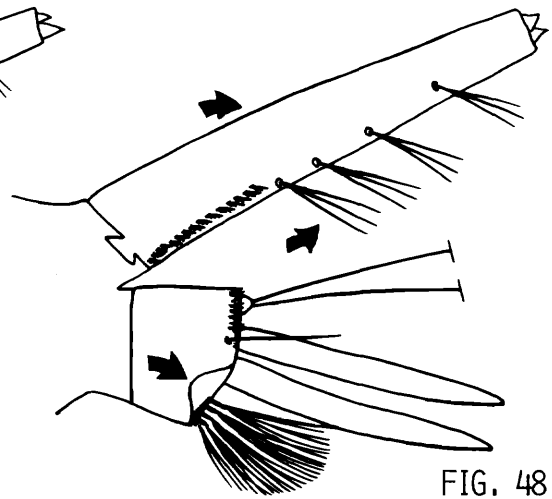

FIG. 48

6. Head hair 1-C slender and brown (Fig. 49) . . . . . 7  
 Head hair 1-C stout and darker (Fig. 50) . . . . . 10

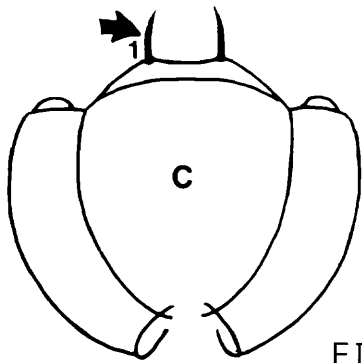

FIG. 49

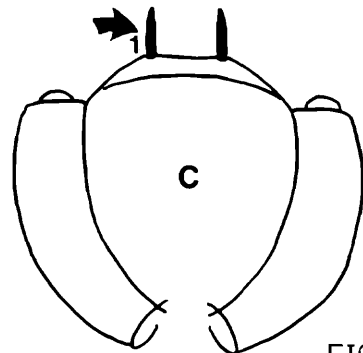

FIG. 50

7. Siphon hair tufts strong, arranged in a zigzag ventral row and evenly spaced, siphon without lateral hair tuft (Fig. 51) . . . . . *Cu. inatomii*  
 Siphon hair tufts weak, arranged usually in a regular subventral row, siphon with lateral hair tuft (Fig. 52) . . . . . 8

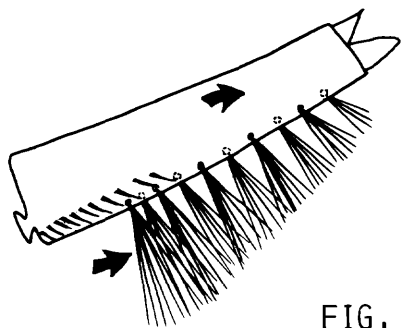

FIG. 51

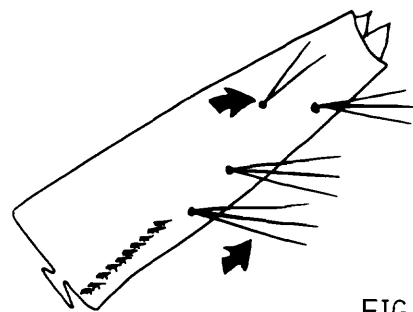

FIG. 52

8. Siphon with 4 pairs of subventral hairs; siphon long, usually 4 to 5 times longer than its basal width (Fig. 53). . . . . *Cu. vagans*
- Siphon with 3 pairs of subventral hairs; siphon short, approximately 3 times longer than its basal width (Fig. 54). . . . . 9

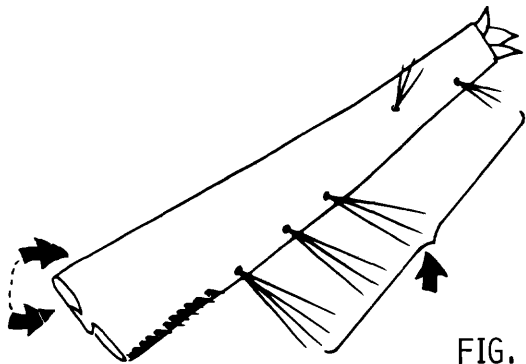

FIG. 53

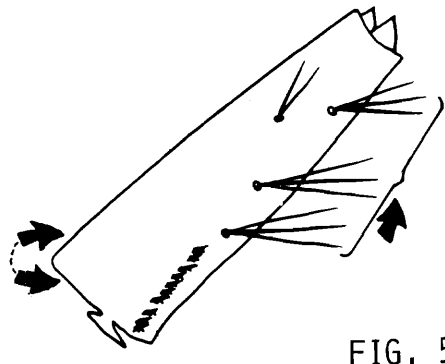

FIG. 54

9. Siphon widest at base (Fig. 55). . . . . *Cu. pipiens pallens*
- Siphon widest at basal third (Fig. 56). . . . . *Cu. pipiens quinquefasciatus*

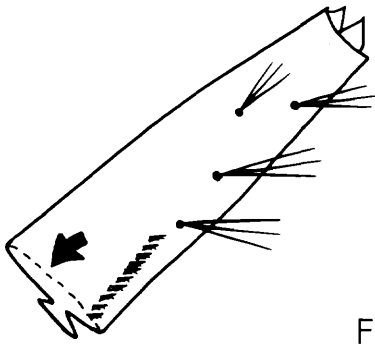

FIG. 55

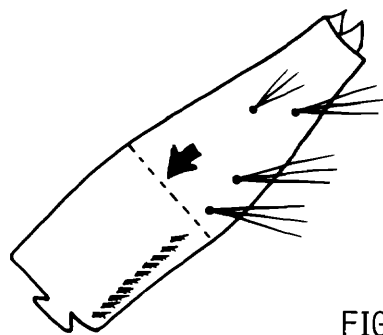

FIG. 56

10. Comb with 3-14 large scales (Fig. 57). . . . . 11
- Comb with more than 20 smaller scales (Fig. 58) . . . . . 14

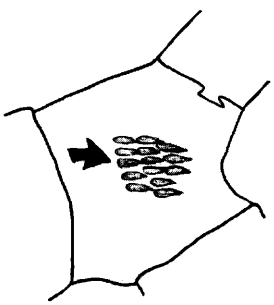

FIG. 57

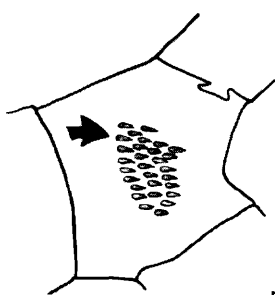
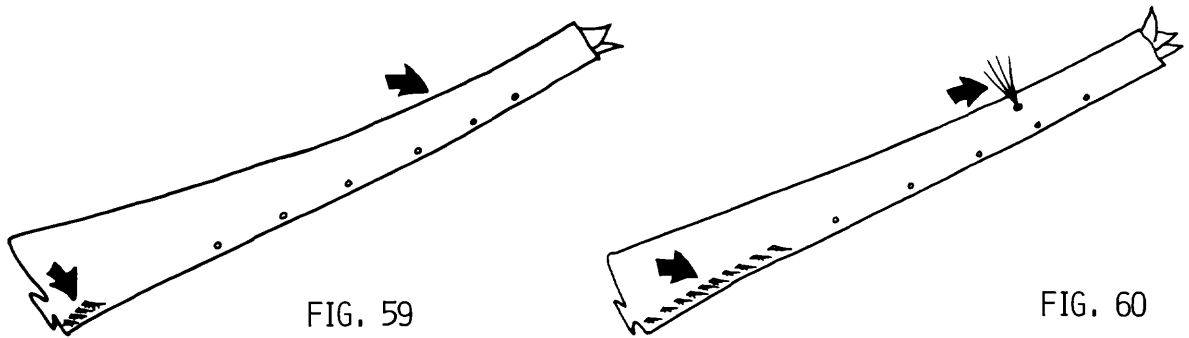
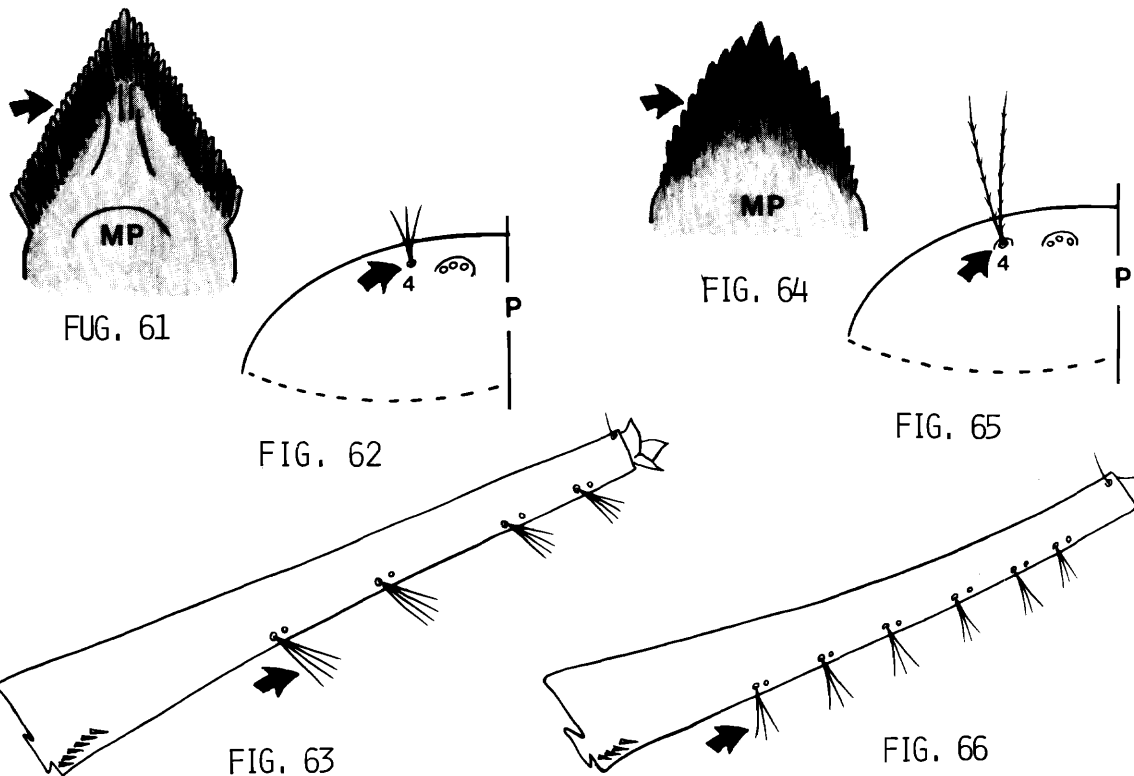

FIG. 58

11. Pecten with 1-8 teeth; siphon without lateral hair tuft (Fig. 59) . . . . . 12  
 Pecten with 6-14 teeth; siphon with lateral hair tuft (Fig. 60) . . . . . 13



12. Mentum plate with extremely small and numerous teeth (Fig. 61); thoracic hair 4-P short, smooth (Fig. 62); siphon with 4 pairs of subventral hair tufts (Fig. 63) . . . . . *Cu. bitaeniorhynchus*  
 Mentum plate with coarse apical teeth, diminishing gradually toward base (Fig. 64); thoracic hair 4-P long, barbed (Fig. 65); siphon with 6 pairs of subventral hair tufts (Fig. 66) . . . . . *Cu. sinensis*



13. Subventral hairs of siphon about half as long as siphon (Fig. 67) . . . . . *Cu. whitmorei*  
 Subventral hairs of siphon less than half as long as siphon (Fig. 68) . . . . . *Cu. pseudovishnui*

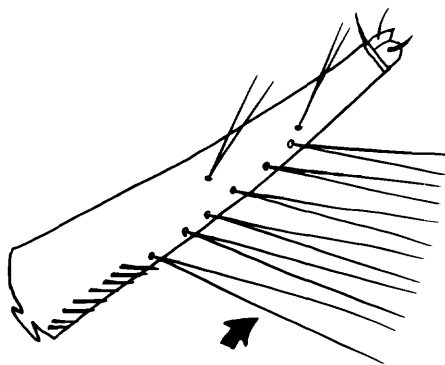

FIG. 67

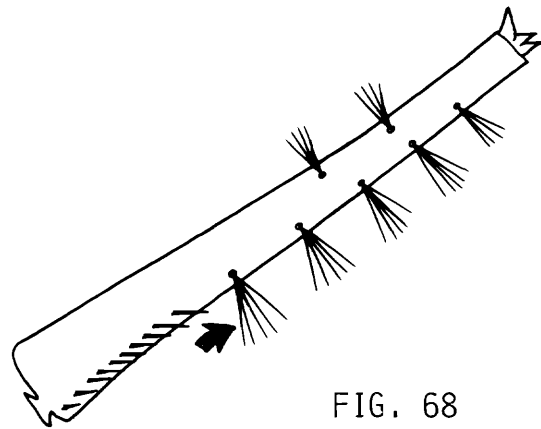

FIG. 68

14. Head hair 1-C very thick, rather blunt (Fig. 69); anal gills very short and rounded, slightly longer than wide (Fig. 70) . . . . . *Cu. sitiens*  
 Head hair 1-C not thick, sharply pointed (Fig. 71); anal gills at least 3 times as wide, usually longer than anal segment (Fig. 72) . . . . . 15

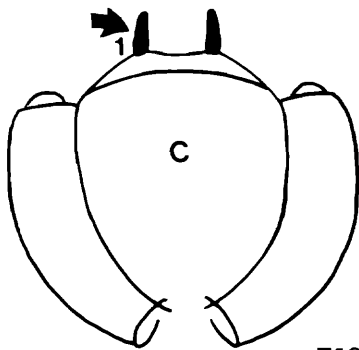

FIG. 69

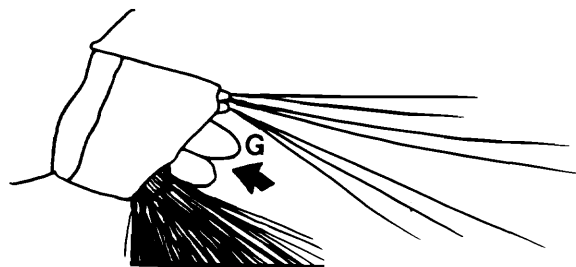

FIG. 70

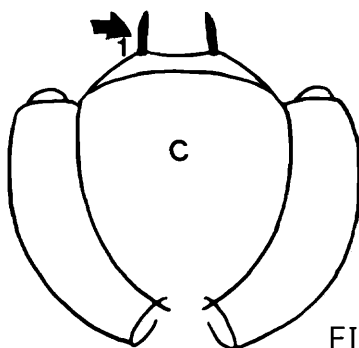

FIG. 71

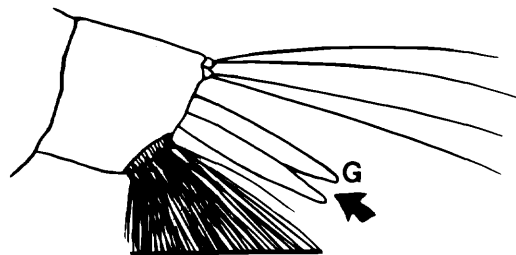
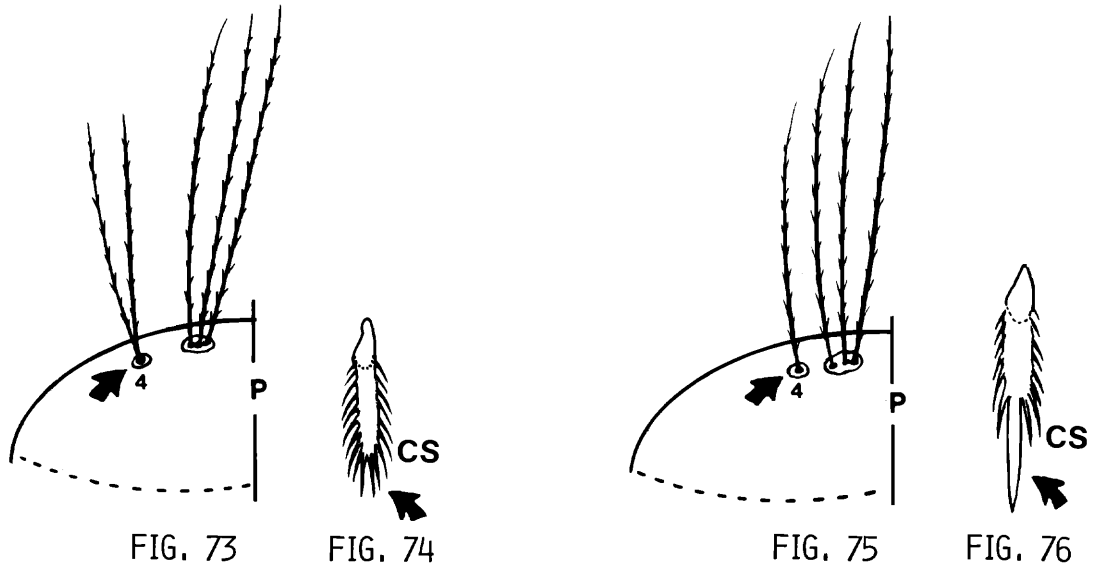
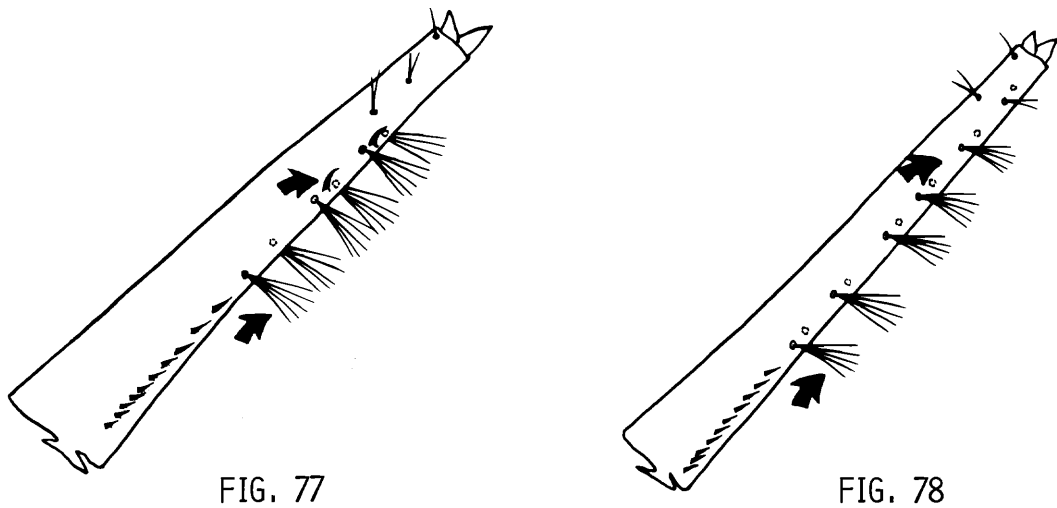

FIG. 72

15. Thoracic hair 4-P bibranched (Fig. 73); comb scales fringed apically and laterally (Fig. 74) . . . . . *Cu. tritaeniorhynchus*  
 Thoracic hair 4-P single (Fig. 75); comb scales pectinate on each side with spiniform tip (Fig. 76) . . . . . 16



16. Siphon with 2 pair of strong subventral spines on apical half of siphon tube; siphon with 6-8 subventral hair tufts (Fig. 77) . . . . . *Cu. jacksoni*  
 Siphon without spines; siphon with 9-14 subventral hair tufts (Fig. 78) . . . . . 17



17. Head hair 4-C with 3-5 branches (Fig. 79);  
 thoracic hair 13-T with 1-3 branches (Fig.80) . . . . . *Cu. mimeticus*
- Head hair 4-C with 1-2 branches (Fig. 81);  
 thoracic hair 13-T with usually more than  
 10 branches (Fig. 82) . . . . . *Cu. orientalis*

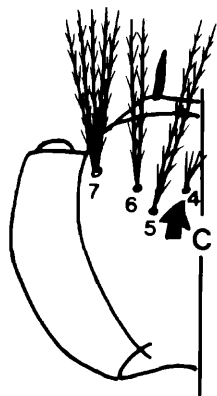

FIG. 79

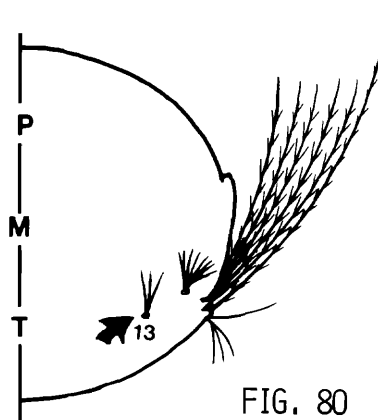

FIG. 80

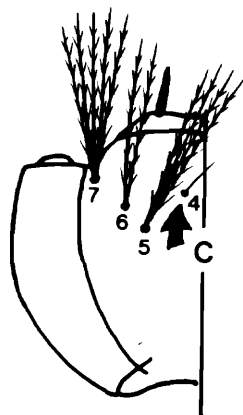

FIG. 81

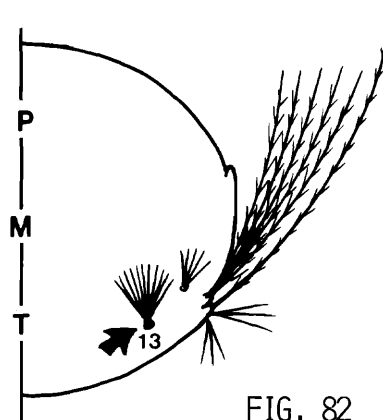

FIG. 82



KEY TO THE SPECIES OF AEDES AND HEIZMANNIA LARVAE

- 1. 3-20 large comb scales in a single row, or in an irregular row, or more or less in 2 rows (Fig. 83) . . . . . 2
- 20-70 comb scales usually smaller, arranged in several rows, or more or less in a triangular patch (Fig. 84) . . . . . 10

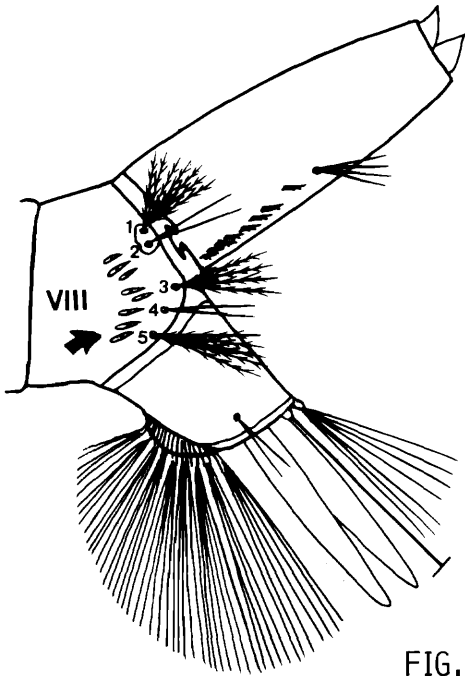

FIG. 83

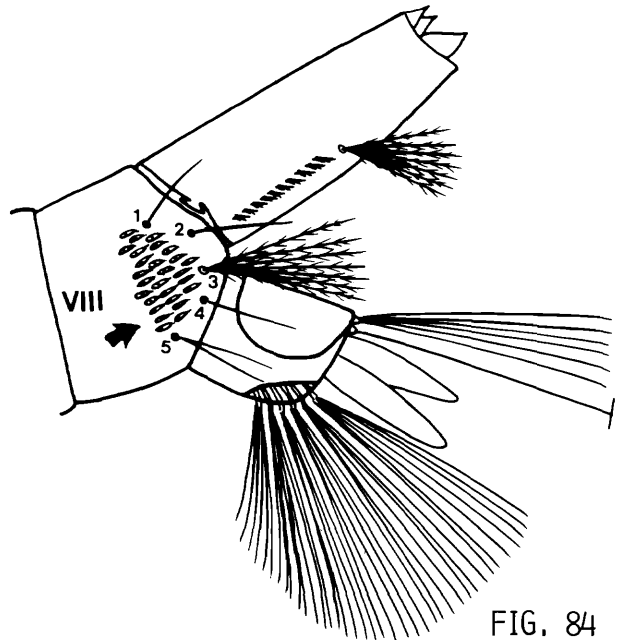

FIG. 84

- 2. Antennal shaft smooth (Fig. 85) . . . . . 3
- Antennal shaft with small spicules or spines (Fig. 86) . . . . . 6

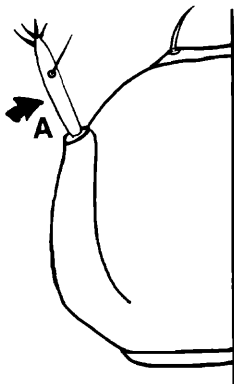

FIG. 85

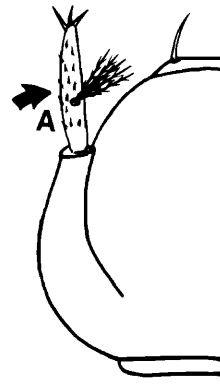

FIG. 86

3. Comb scales with 2-4 strong basal lateral spines on each side (Fig. 87). . . . . *Ae. chemulpoensis*  
 Comb scales without basal lateral spines, but finely fringed (Fig. 88). . . . . 4

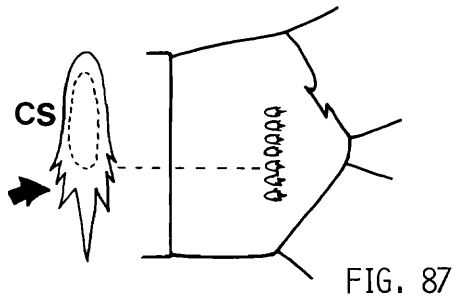

FIG. 87

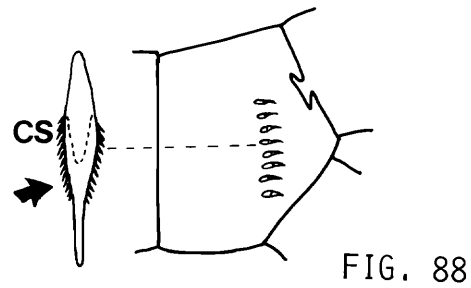

FIG. 88

4. Abdominal hairs 1,5-VIII with less than 4 branches (Fig. 89). . . . . *Ae. albopictus*  
 Abdominal hairs 1,5-VIII with more than 6 branches (Fig. 90). . . . . 5

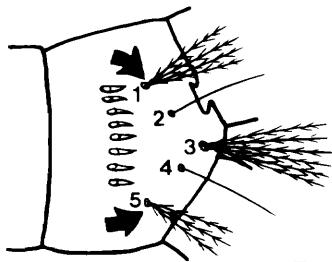

FIG. 89

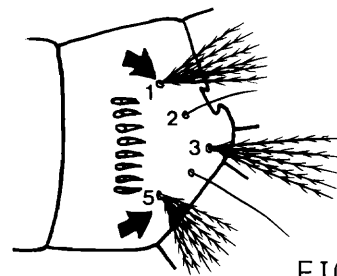

FIG. 90

5. Thoracic hair 14-P with more than 4 branches (Fig. 91); saddle incomplete (Fig. 92). . . . . *Ae. flavopictus flavopictus*  
 Thoracic hair 14-P with 2 branches (Fig. 93); saddle usually complete (Fig. 94). . . . . *Ae. galloisi*

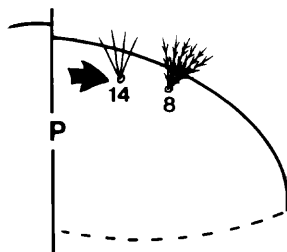

FIG. 91

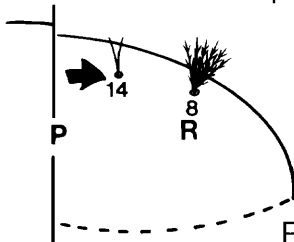

FIG. 92

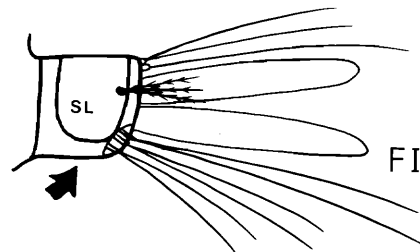

FIG. 93

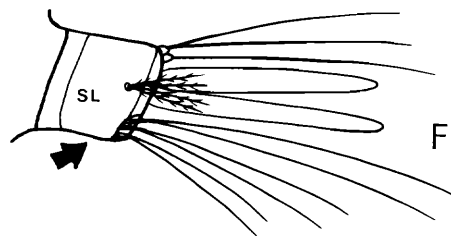

FIG. 94

6. All pecten teeth evenly spaced and all about same size (Fig. 95); head hair 4-C as large as 5-C (Fig. 96) . . . . . *Ae. nipponicus*

The 1-3 pecten teeth furthest from base of siphon more widely spaced than basal teeth (Fig. 97); head hair 4-C much smaller than 5-C (Fig. 98) . . . . . 7

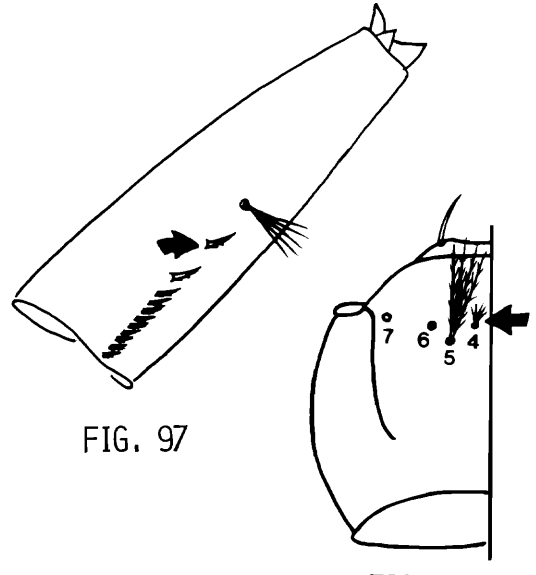
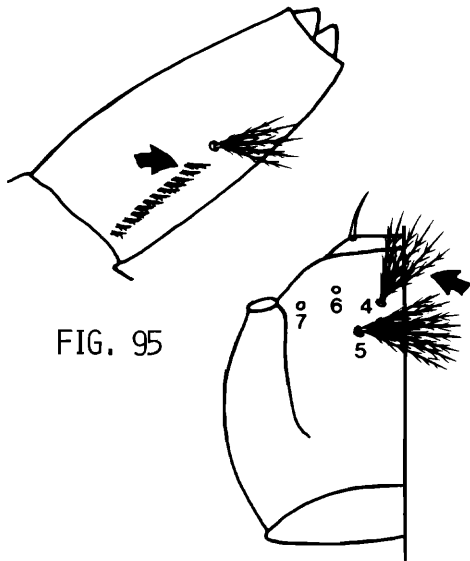

FIG. 95

FIG. 96

FIG. 97

FIG. 98

7. Siphon with minute, 2-5 branched hairs near apex (Fig. 99) . . . . . *Ae. esoensis*

Siphon without minute hair near apex (Fig. 100) . . . . . 8

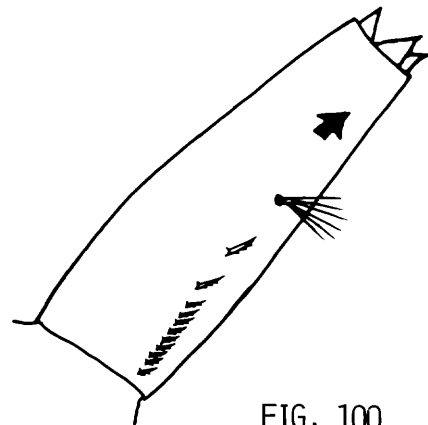
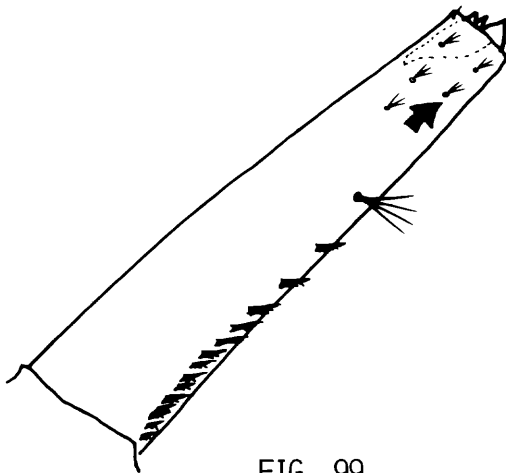

FIG. 99

FIG. 100

8. Head hair 6-C single or bifid; 5,6,7-C not on a line (Fig. 101). . . . . *Ae. vexans nipponii*  
 Head hair 6-C with 5 or more branches; 5,6,7-C on a line (Fig. 102). . . . . 9

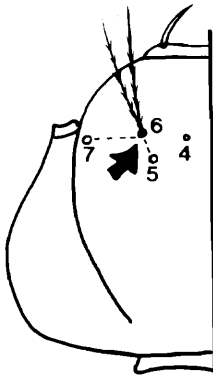

FIG. 101

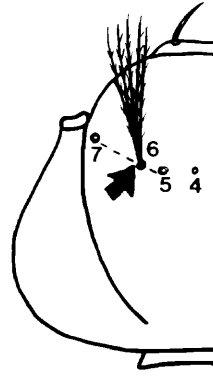

FIG. 102

9. Combscales 16-20 (usually 20), individual scales rounded (Fig. 103). . . . . *Ae. alboscuteUellatus*  
 Combscales 8-12, individual scales thorn shaped (Fig. 104). . . . . *Ae. lineatopennis*

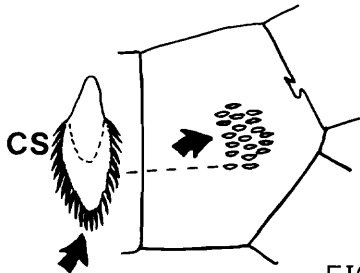

FIG. 103

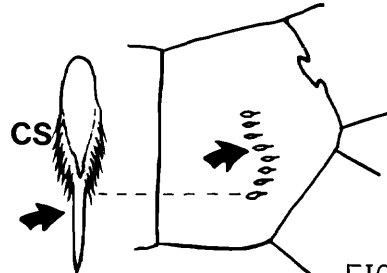

FIG. 104

10. Thoracic seta 1-M and 1-T very stout, on sclerotized basal callus (Fig. 105). . . . . *Ae. hatorii*  
 Thoracic seta 1-M and 1-T weak, not on sclerotized basal callus (Fig. 106). . . . . 11

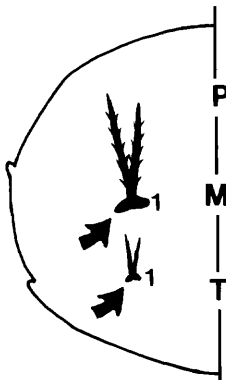

FIG. 105

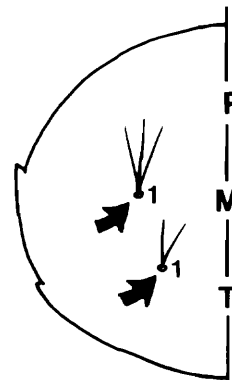

FIG. 106

11. Head hair 6-C very long, longer than head length (Fig. 107) . . . . . *Ae. alektorovi*  
 Head hair 6-C not longer than head length (Fig. 108) . . . . . 12

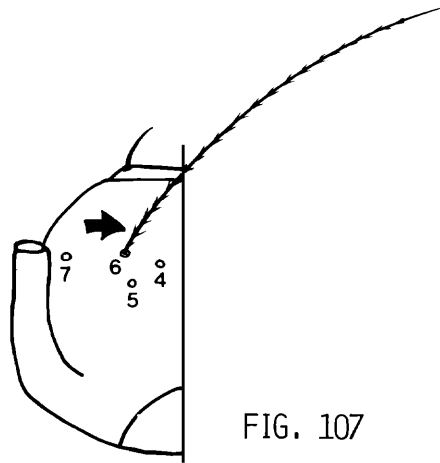

FIG. 107

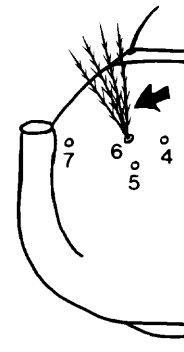

FIG. 108

12. Pecten teeth fringed on both side (Fig. 109) . . . . . *Ae. seoulensis*  
 Pecten teeth with basal spines on one side (Fig. 110) . . . . . 13

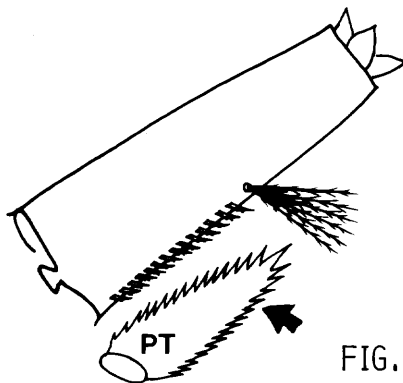

FIG. 109

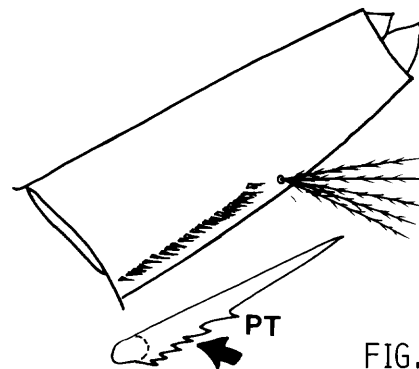

FIG. 110

13. Head hair 5-C single (Fig. 111) . . . . . 14  
 Head hair 5-C branched (Fig. 112) . . . . . 15

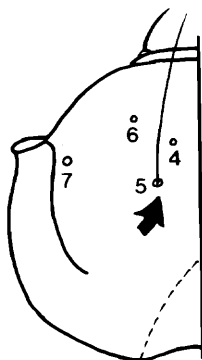

FIG. 111

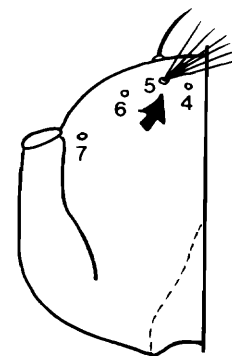

FIG. 112

14. Head hair 6-C branched; antennal hair 1-A single (Fig. 113) . . . . . *Ae. oreophilus*  
 Head hair 6-C single; antennal hair 1-A branched (Fig. 114) . . . . . *Ae. dorsalis*

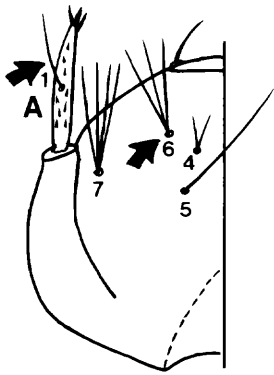

FIG. 113

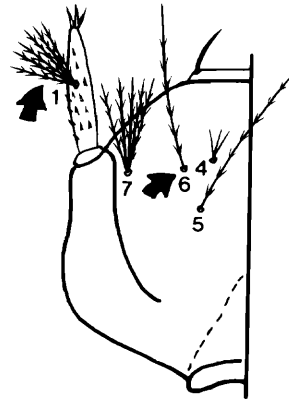

FIG. 114

15. Head hair 6-C with 2 branches; 4-C nearly as long as 5-C (Fig. 115) . . . . . *Heizmannia lii*  
 Head hair 6-C with several branches; 4-C smaller than 5-C (Fig. 116) . . . . . 16

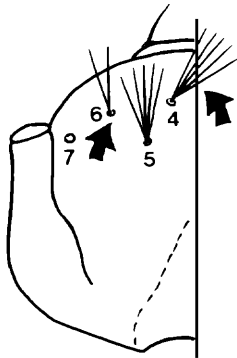

FIG. 115

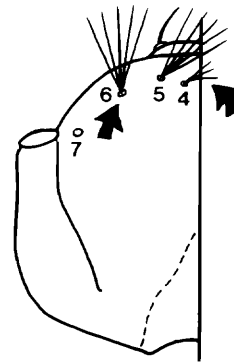

FIG. 116

16. Siphonal hair near apex (Fig. 117); anal gills very short and round (Fig. 118) . . . . . *Ae. togoi*  
 Siphonal hair toward middle of siphon (Fig. 119); anal gills at least 3 times as long as wide (Fig. 120) . . . . . 17

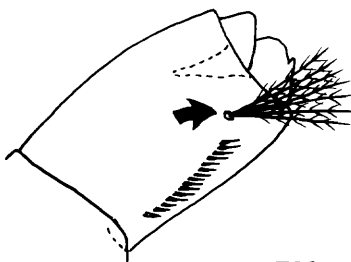

FIG. 117

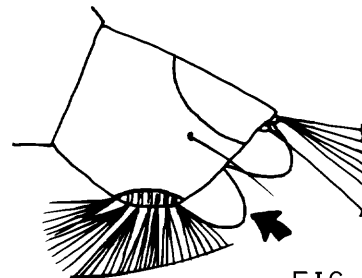

FIG. 118

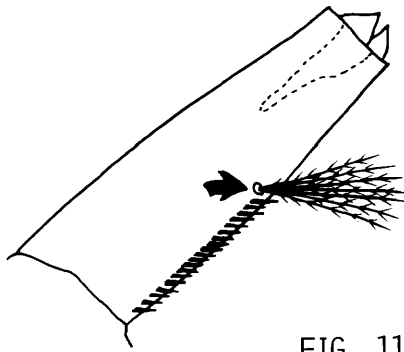

FIG. 119

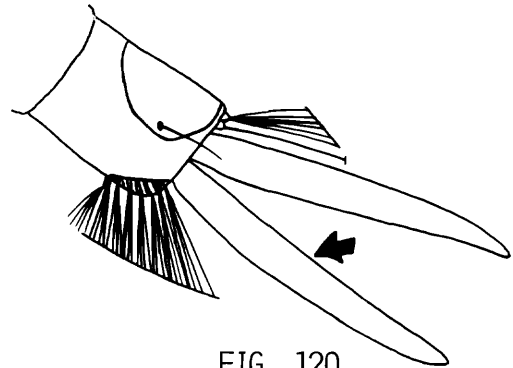

FIG. 120

17. Pecten with distal teeth widely spaced,  
 extending beyond siphon hair to near apex  
 (Fig. 121) . . . . . *Ae. japonicus japonicus*  
 Pecten with all teeth more or less evenly  
 spaced, not extending beyond siphon hair  
 (Fig. 122) . . . . . *Ae. koreicus*

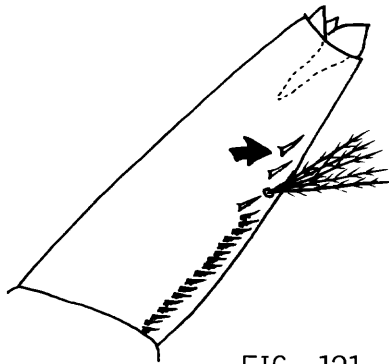

FIG. 121

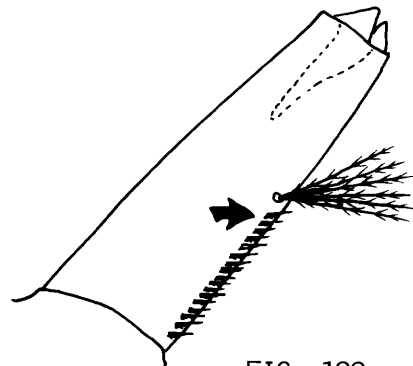

FIG. 122