

---

NORTH ATLANTIC TREATY  
ORGANISATION



AC/323(SCI-203)TP/471

RESEARCH AND TECHNOLOGY  
ORGANISATION



[www.sto.nato.int](http://www.sto.nato.int)

---

**RTO AGARDograph 300**  
**Flight Test Technique Series – Volume 28**

**AG-300-V28**

# **Electronic Warfare Test and Evaluation**

(Essai et évaluation en matière  
de guerre électronique)

This AGARDograph has been sponsored by the  
Systems Concepts and Integration Panel.

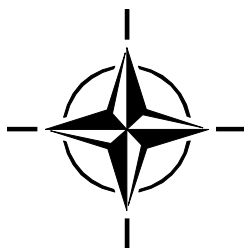

Published December 2012

---

*Distribution and Availability on Back Cover*



---

NORTH ATLANTIC TREATY  
ORGANISATION



AC/323(SCI-203)TP/471

RESEARCH AND TECHNOLOGY  
ORGANISATION



[www.sto.nato.int](http://www.sto.nato.int)

---

**RTO AGARDograph 300**  
**Flight Test Technique Series – Volume 28**

**AG-300-V28**

# **Electronic Warfare Test and Evaluation**

(Essai et évaluation en matière  
de guerre électronique)

This AGARDograph has been sponsored by the  
Systems Concepts and Integration Panel.

by

Mr. Martin Welch

Mr. Mike Pywell

---

# The Research and Technology Organisation (RTO) of NATO

RTO is the single focus in NATO for Defence Research and Technology activities. Its mission is to conduct and promote co-operative research and information exchange. The objective is to support the development and effective use of national defence research and technology and to meet the military needs of the Alliance, to maintain a technological lead, and to provide advice to NATO and national decision makers. The RTO performs its mission with the support of an extensive network of national experts. It also ensures effective co-ordination with other NATO bodies involved in R&T activities.

RTO reports both to the Military Committee of NATO and to the Conference of National Armament Directors. It comprises a Research and Technology Board (RTB) as the highest level of national representation and the Research and Technology Agency (RTA), a dedicated staff with its headquarters in Neuilly, near Paris, France. In order to facilitate contacts with the military users and other NATO activities, a small part of the RTA staff is located in NATO Headquarters in Brussels. The Brussels staff also co-ordinates RTO's co-operation with nations in Middle and Eastern Europe, to which RTO attaches particular importance especially as working together in the field of research is one of the more promising areas of co-operation.

The total spectrum of R&T activities is covered by the following 7 bodies:

- AVT Applied Vehicle Technology Panel
- HFM Human Factors and Medicine Panel
- IST Information Systems Technology Panel
- NMSG NATO Modelling and Simulation Group
- SAS System Analysis and Studies Panel
- SCI Systems Concepts and Integration Panel
- SET Sensors and Electronics Technology Panel

These bodies are made up of national representatives as well as generally recognised 'world class' scientists. They also provide a communication link to military users and other NATO bodies. RTO's scientific and technological work is carried out by Technical Teams, created for specific activities and with a specific duration. Such Technical Teams can organise workshops, symposia, field trials, lecture series and training courses. An important function of these Technical Teams is to ensure the continuity of the expert networks.

RTO builds upon earlier co-operation in defence research and technology as set-up under the Advisory Group for Aerospace Research and Development (AGARD) and the Defence Research Group (DRG). AGARD and the DRG share common roots in that they were both established at the initiative of Dr Theodore von Kármán, a leading aerospace scientist, who early on recognised the importance of scientific support for the Allied Armed Forces. RTO is capitalising on these common roots in order to provide the Alliance and the NATO nations with a strong scientific and technological basis that will guarantee a solid base for the future.

The content of this publication has been reproduced directly from material supplied by RTO or the authors.

Published December 2012

Copyright © STO/NATO 2012  
All Rights Reserved

ISBN 978-92-837-0172-9

Single copies of this publication or of a part of it may be made for individual use only. The approval of the RTA Information Management Systems Branch is required for more than one copy to be made or an extract included in another publication. Requests to do so should be sent to the address on the back cover.



---

## AGARDograph Series 160 & 300

Soon after its founding in 1952, the Advisory Group for Aerospace Research and Development (AGARD) recognized the need for a comprehensive publication on Flight Test Techniques and the associated instrumentation. Under the direction of the Flight Test Panel (later the Flight Vehicle Integration Panel, or FVP) a Flight Test Manual was published in the years 1954 to 1956. This original manual was prepared as four volumes: 1. Performance, 2. Stability and Control, 3. Instrumentation Catalog, and 4. Instrumentation Systems.

As a result of the advances in the field of flight test instrumentation, the Flight Test Instrumentation Group was formed in 1968 to update Volumes 3 and 4 of the Flight Test Manual by publication of the Flight Test Instrumentation Series, AGARDograph 160. In its published volumes AGARDograph 160 has covered recent developments in flight test instrumentation.

In 1978, it was decided that further specialist monographs should be published covering aspects of Volumes 1 and 2 of the original Flight Test Manual, including the flight testing of aircraft systems. In March 1981, the Flight Test Techniques Group (FTTG) was established to carry out this task and to continue the task of producing volumes in the Flight Test Instrumentation Series. The monographs of this new series (with the exception of AG237 which was separately numbered) are being published as individually numbered volumes in AGARDograph 300. In 1993, the Flight Test Techniques Group was transformed into the Flight Test Editorial Committee (FTEC), thereby better reflecting its actual status within AGARD. Fortunately, the work on volumes could continue without being affected by this change.

An Annex at the end of each volume in both the AGARDograph 160 and AGARDograph 300 series lists the volumes that have been published in the Flight Test Instrumentation Series (AG 160) and the Flight Test Techniques Series (AG 300) plus the volumes that were in preparation at that time.

---

# **Electronic Warfare Test and Evaluation**

## **(RTO-AG-300-V28)**

### **Executive Summary**

Control and exploitation of the electromagnetic spectrum has become as much a part of modern warfare as air superiority or dominance of the sea lanes. Electronic Warfare (EW) is the mission area responsible for establishing and maintaining a favourable position in the electromagnetic domain. Test and evaluation (T&E) of those devices used on modern military aircraft to prosecute this critical mission area requires the use of a wide range of test techniques and analytical methods to assure users of the readiness of EW systems to meet the challenges of the combat environment. Actual in-flight testing comprises a relatively small portion of the EW T&E process. As a result, the reader will find that the concentration in this handbook is far broader than 'flight test' – ranging from laboratory efforts to establish the system performance baseline through complex ground-based simulations and finally the limited verification accomplished in the open air range environment.

This handbook is intended as an introductory text dedicated to EW systems T&E. While other volumes in the Flight Test Techniques Series have provided limited coverage of EW system testing, they have been generally aimed at a broad view of T&E and have not resulted in a singular focused handbook on EW test techniques.

While the primary goal of this handbook is to introduce the novice to a disciplined approach to EW testing, it will also serve more experienced testers and programme managers as a concise reference for the EW test process and test resources. It begins with an overview of the test process in the context of the roles and missions expected of EW systems. Subsequent chapters provide examples of test requirements for major categories of EW systems. The final chapters focus on descriptions of specific types of test resources and how they can be linked to simulate predicted operational conditions. A catalogue of some useful EW Test Facilities is included in an annex to this handbook.

The original version of the handbook has been updated to include additional details with previous treatments while introducing new material and greatly expanding the use of figures as an aid to understanding. New material includes discussions about the T&E of infrared countermeasures systems, radio frequency towed decoy systems, low observable systems, and directed energy weapons (High-Power Microwave [HPM] and High-Energy Lasers [HEL]). The chapters addressing T&E resources, modelling and simulation, and lessons learned have been updated to account for advances in the last decade. The annex providing a sample of the member Nations' EW T&E facilities has also been updated.

# Essai et évaluation en matière de guerre électronique (RTO-AG-300-V28)

## Synthèse

Le contrôle et l'exploitation du spectre électromagnétique sont devenus une composante à part entière de la guerre moderne, au même titre que la supériorité aérienne ou la maîtrise des couloirs maritimes. La guerre électronique (GE) constitue le champ de mission responsable de l'établissement et du maintien d'une position favorable dans le domaine de l'électromagnétique. L'essai et l'évaluation (E&E) des appareils utilisés à bord des avions militaires modernes pour mettre en œuvre ce champ de mission critique nécessitent une large batterie de techniques d'essai et de méthodes d'analyse, ce afin de garantir aux utilisateurs un niveau de préparation des systèmes de GE qui répondent aux défis de l'environnement de combat. Les essais en vol réel ne représentent qu'une part relativement faible du procédé d'E&E de GE. En conséquence, comme pourra le constater le lecteur, les sujets de ce manuel s'étendent au-delà de « l'essai en vol », allant des activités en laboratoire visant à établir la référence de performance du système jusqu'à la vérification limitée obtenue dans un environnement aérien ouvert en passant par des simulations au sol complexes.

Ce manuel fait office d'introduction aux E&E des systèmes de GE. Tandis que d'autres volumes de la série des Techniques d'essais en vol ont apporté des informations limitées sur les essais des systèmes de GE, ils étaient généralement destinés à fournir un large aperçu des E&E et n'ont pas abouti à l'élaboration d'un manuel unique axé sur les techniques d'essai de GE.

Bien que ce manuel ait pour principal objectif de présenter au novice une approche disciplinée des essais de GE, il est également utile aux contrôleurs des essais et directeurs de programme en tant qu'objet concis de référence pour le procédé d'essai de GE et les ressources d'essai. Il s'ouvre sur une présentation d'ensemble du procédé d'essai dans le contexte des rôles et missions escomptés des systèmes de GE. Les chapitres qui suivent offrent des exemples d'impératifs d'essais pour les grandes catégories de systèmes de GE. Les derniers chapitres portent essentiellement sur des descriptions de types spécifiques de ressources d'essai et sur la manière dont on peut les associer pour simuler des conditions opérationnelles prédites. Un catalogue non exhaustif de Centres d'essai de GE utiles est inclus en annexe de ce manuel.

La version d'origine de ce manuel a été mise à jour pour apporter des détails supplémentaires à des traitements antérieurs, tout en présentant de nouveaux supports et en exploitant plus largement les données chiffrées afin de faciliter la compréhension. Les nouveaux supports incluent des discussions relatives aux E&E des systèmes de contre-mesures infrarouges, systèmes de leurre à radiofréquences remorqué, systèmes furtifs et armes à énergie dirigée (hyperfréquences à grande puissance [HPM] et laser à énergie élevée [HEL]). Les chapitres traitant des ressources d'E&E, de la modélisation et de la simulation, ainsi que de l'expérience acquise, ont été mis à jour pour tenir compte des avancées des dix dernières années. L'annexe proposant un échantillon des centres d'E&E de GE des Etats membres a également été mise à jour.

---

## Acknowledgements

The authors of this update acknowledge the stalwart efforts of the editors, H. Banks and R. McQuillan, and the many contributors to the original version of this Handbook. That version has already stood the test of time, having been a useful and widely available reference work for more than a decade for those active in the field of EW T&E – engineers, managers, researchers, academics and those new to EW. The original version has formed an excellent and solid basis for this update, with some sections requiring only minor amendments – indeed a testament to the knowledge and wisdom of the original authors.

Acknowledgement is given to contributors to this update, especially the agencies and companies who have kindly provided the photographs that the co-authors hope will make this update more informative than its predecessor. The authors are grateful for the guidance and assistance of Mr. Carter Wilkinson, FT3 Champion for SCI-203, and for the FT3 Group's comments on the drafts of the update, especially those of Mr. Bertil Gustavsson (Swedish FMV: Test & Evaluation's Chief Flight Test Engineer). Thanks also go to the following, whose assistance has helped the co-authors during this three-year SCI-203 tasking: Mr. Mitch Midgley-Davies (EW Test Facility), Mrs. Alison Heminsley (Head of M&S), Mr. Tony Shields (Systems Test Department) and Mr. Ian MacDiarmid (Head of Electromagnetics), all of BAE SYSTEMS – Military Air and Information. Thanks for input also go to Mr. Gordon Slater (Slater Aerosystems Ltd.).

The authors would also like to thank Mr. Steve Ruthven, Ms. Theresa Pham, Mr. Mario Dorado, and Mr. David Krohman of the 412th EW Group for their thorough review of the document and helpful suggestions. Mr. Lyndell Brown's (Tybrin Corporation) expertise and contribution to the High-Power Microwave and High Energy Lasers section was invaluable and is greatly appreciated. The technical editing support provided by Ms. Terressa Schmitz (JT3 Corporation) and Ms. Carolyn Rogers (JT3 Corporation) of the 412th Test Wing was also extremely helpful and is greatly appreciated.

The authors also acknowledge permission to use some material from prior publications by M. Pywell: the Institution of Engineering and Technology, Wiley & Sons (Encyclopedia of Aerospace Engineering) and the Royal Aeronautical Society.

Finally, the co-authors would like to thank their agencies, the U.S. Air Force Flight Test Center and BAE Systems (Military Air and Information), for support during the SCI-203 task to update this Handbook.

## Foreword

While other volumes in the Flight Test Techniques Series have provided limited coverage of Electronic Warfare (EW) system testing, they have been generally aimed at a broad view of test and evaluation (T&E) and have not resulted in a singular, focused handbook on EW test techniques. This volume has as its sole focus the processes, techniques, facilities, and goals of T&E of modern EW systems. Much of the world of EW remains shrouded in secrecy, and detailed descriptions of some test resources, test results, and EW techniques cannot be presented herein. However, this volume can fulfil its desired goal of serving as a comprehensive introduction to the practice of EW test.

The first chapter provides a historical perspective of EW system development, an overview of EW systems, and basic motivations for T&E. The reader will quickly realise that the development and eventual qualification of EW systems is heavily reliant on the use of ground-based T&E resources. Since EW system performance is substantially scenario-dependent, much of the testing must be accomplished in a combat-representative electromagnetic environment. These high density and wildly dynamic conditions can only be offered to the tester through the application of complex models, simulations, and analytical processes.

Chapters 2, 3, and 4 of this handbook examine the motivation for testing each of the three primary classes of EW systems: EW Support Systems, Electronic Attack Systems, and Electronic Protect Systems. The characteristics of each type of system are discussed and examples of test objectives, measures of performance (MOPs) (a more detailed discussion of MOPs has been included as Annex B), and test resource utilisation are discussed. Chapter 5 introduces architectural considerations for EW Systems and discusses how various architectures may affect the test approach.

The EW Test Process, defined in Chapter 1, is based on an organised application of test resources including measurement facilities, models, simulations, hardware-in-the-loop facilities, installed system test facilities, and open air ranges. Chapter 6 describes the EW T&E resource types in detail, while Chapter 7 covers the important topic of modelling and simulation and threat simulation. EW T&E mission execution is complex and expensive and Chapter 8 describes the essential elements of EW flight test planning, execution and operations. Finally, some lessons learned in the T&E of EW systems have been collected in Chapter 9. While the specific issues depicted by these anecdotes may not be present in some future test programme, the general nature of the lessons may be useful in avoiding costly, time-consuming and often preventable problems.

This handbook also includes five Annexes. Annex A is a catalogue of some NATO EW Test Facilities. Annex B provides an enhanced discussion of MOPs and related test considerations. Annex C shows the derivation of the jam-to-signal ratio for two important cases. Annex D provides a Glossary and Annex E lists previous 160 and 300 series AGARDograph publications.

Overall, this handbook will help the novice EW tester become familiar with the major elements of EW T&E. More experienced testers will find the handbook to be a helpful reference source with a concise description of both test processes and test resources throughout the U.S. and Europe. For those individuals with broader responsibilities in the acquisition, operations, or sustainment of EW systems, this volume will be a useful introduction to the potential for gaining in-depth understanding of EW system functionality and performance through the disciplined application of the EW test process.

## Preface



Mr. Martin Welch is a technical expert for 412th Electronic Warfare Group at the U.S. Air Force Flight Test Center, at Edwards AFB, California. He has been involved in the T&E of avionics, EW systems, and aircraft survivability technologies for 27 years. Since 2001, he has also served as the Director of the 412th EW Group's EW T&E University where he has played an instrumental role in educating the next generation of EW T&E professionals. He has been involved with the T&E of numerous radio frequency and infrared countermeasures systems as well as low observable and aircraft survivability technologies on a variety of platforms including the MC-130H Combat Talon II, AC-130U gunship, F-16, B-2A, and the F-117A.

Mr. Welch received Bachelor of Science degrees in Aerospace and Mechanical Engineering from Tri-State University in Angola, Indiana and a Master of Science degree in Electrical Engineering from the U.S. Naval Postgraduate School in Monterey, CA. Mr. Welch is also a graduate (by correspondence) of the USAF Air Command and Staff College and the Air War College.



Mr. Mike Pywell is an EW Technologist in the Electromagnetic Engineering Department at BAE Systems – Military Air and Information Division, U.K. He has been involved in T&E of avionics, EW systems, and survivability technologies for 37 years, and is an internationally recognised expert on RF threat simulators. For seven years he was also the Unit's RF and Laser Safety Officer, and for 11 years was also the division's EW Technology Programme Manager. He has been involved with T&E of Defensive Aids and RF communications systems on a number of platform types, and has an extensive background in electromagnetic interference and compatibility. He was a key player in the design of the company's aircraft-sized EW Test Facility and, more recently, led the multi-£M project to update its instrumentation.

For over 13 years he has represented the U.K. and his company on various NATO activities, including NATO Research and Technology Organisation (RTO) Studies SAS-011 (*Requirements and Options for Future NATO EW Capabilities*) and SAS-064 (*Update of Requirements and Options for Future NATO Airborne EW Capabilities*), and NATO Industrial Advisory Group (NIAG) Study Groups SG-66 (*Future Electronic Support System – Digital Solutions*), SG-79 (*Emitter Location and Data Links to facilitate Suppression of Enemy Air Defence*), and SG-105 (*Self-Protection interoperability (Flare/Chaff) for Aircraft and UAVs*). He has written several peer-reviewed journal and conference papers on Survivability and EW topics, and in 2007 won a Written Paper Prize (Silver Award) from the U.K.'s Royal Aeronautical Society. In 2010, he had two invited chapters published in the Encyclopedia of Aerospace Engineering: '*Electronic Warfare and Defensive Aids Systems Design and Development*' and '*Design Aspects of Aircraft Vulnerability*'.

Mr. Pywell received a Bachelor of Science degree in Electrical and Electronic Engineering from Coventry University and a Master of Philosophy degree from the University of Central Lancashire, where he has been a Senior Visiting Research Fellow since 2004. He is a Chartered Engineer and a Fellow of the Institution of Engineering and Technology.

# Table of Contents

	Page
<b>AGARDograph Series 160 &amp; 300</b>	<b>iii</b>
<b>Executive Summary</b>	<b>iv</b>
<b>Synthèse</b>	<b>v</b>
<b>Acknowledgements</b>	<b>vi</b>
<b>Foreword</b>	<b>vii</b>
<b>Preface</b>	<b>viii</b>
<b>List of Figures</b>	<b>xvii</b>
<b>List of Tables</b>	<b>xx</b>
<b>List of Acronyms and Symbols</b>	<b>xxi</b>
<b>Author Contact Information</b>	<b>xxviii</b>
<b>Chapter 1 – Introduction to EW Test and Evaluation</b>	<b>1-1</b>
1.1 Purpose and Scope	1-1
1.2 Background	1-2
1.3 History of EW	1-2
1.4 EW Definitions and System Classification	1-6
1.4.1 EW and Related Definitions	1-6
1.4.2 EW System Architecture Classifications	1-7
1.4.3 System Hierarchy	1-9
1.5 Test Resource Categories	1-9
1.6 The Acceptance Process and Types of Test	1-10
1.7 EW System Application in Warfare	1-12
1.7.1 Overview of EA	1-12
1.7.2 Overview of EP	1-14
1.7.3 Overview of ES	1-14
1.8 The EW T&E Process	1-14
1.8.1 Test Objectives	1-14
1.8.2 Test Design	1-15
1.8.3 Programme Tailoring, Phasing, and Regression Testing	1-17
1.8.4 An Integrated Test Approach	1-18
1.8.5 Data Reduction and Analysis	1-20
1.9 EW T&E Resource Utilisation	1-20
1.9.1 Relative Cost	1-20
1.9.2 Relative Use	1-20
1.10 Safety Considerations	1-21
1.10.1 Electrical Shock Hazards	1-21
1.10.2 Radiation Hazards	1-21
1.10.3 Pyrotechnic Hazards	1-22



1.11	The Test Plan	1-22
1.11.1	Cost and Test Budget	1-22
1.11.2	Schedule	1-22
1.11.3	Test Efficiency	1-22
1.11.4	The Bottom Line	1-22
1.12	Training – A Key to Success	1-23
1.13	References	1-23
1.14	Further Reading	1-24

## **Chapter 2 – T&E of ES Systems** **2-1**

2.1	Introduction	2-1
2.2	RF EW Receivers	2-1
2.2.1	RWR System Components and Operation	2-3
2.2.1.1	Antennas and Transmission Lines	2-4
2.2.1.2	Receiver	2-5
2.2.1.3	Data Processor	2-5
2.2.1.4	Installation and Integration	2-6
2.2.2	EW Receiver Testing (RWR Focus)	2-7
2.2.2.1	Uninstalled RWR Component and System-Level Testing	2-8
2.2.2.2	Installed RWR Testing	2-13
2.2.2.3	Operational Test and Evaluation	2-18
2.3	Missile Warning Systems	2-18
2.3.1	MWS Technologies	2-18
2.3.2	MWS Components and Operation	2-20
2.3.2.1	Sensor	2-21
2.3.2.2	Processor	2-23
2.3.2.3	Display	2-23
2.3.3	MWS Testing	2-23
2.3.3.1	Uninstalled MWS Testing	2-24
2.3.3.2	Installed MWS Testing	2-25
2.4	Laser Warning Systems (LWS)	2-26
2.4.1	LWS Components and Operation	2-26
2.4.1.1	Sensors and Receivers	2-27
2.4.1.2	Processor	2-27
2.4.1.3	Display	2-27
2.4.2	LWS Testing	2-27
2.4.2.1	Uninstalled LWS Testing	2-27
2.4.2.2	Installed LWS Testing	2-28
2.5	References	2-28
2.6	Further Reading	2-29

## **Chapter 3 – T&E of EA Systems** **3-1**

3.1	Introduction	3-1
3.2	RF Self-Protection Jammer	3-2
3.2.1	Radar Operation and Jamming Types	3-2



3.2.2	RFCM System Concepts and Operation	3-4
3.2.2.1	RF Front End and Receiver/Processor	3-5
3.2.2.2	Technique Generator and Transmitter	3-5
3.2.2.3	Transmit Antennas	3-6
3.2.2.4	Displays and Controls	3-6
3.2.2.5	RF Management Systems	3-6
3.2.3	SPJ System Testing	3-6
3.2.3.1	Uninstalled SPJ Component Testing and Performance Assessments	3-7
3.2.3.2	Installed SPJ Testing and Performance Assessments	3-10
3.2.3.3	Additional SPJ T&E Considerations	3-12
3.3	Support Jammers	3-12
3.3.1	Support Jammer System Concepts and Operation	3-13
3.3.2	Support Jammer System Testing	3-14
3.4	RF Towed Decoy Systems	3-15
3.4.1	Towed Decoy System Concepts and Operation	3-15
3.4.2	RF Towed Decoy Testing	3-17
3.4.2.1	Uninstalled Towed Decoy Component Testing	3-17
3.4.2.2	Installed Towed Decoy Testing and Performance Assessments	3-18
3.5	Active Infrared Countermeasures Systems	3-18
3.5.1	Active IRCM System Components and Operation	3-20
3.5.1.1	Countermeasures Codes	3-20
3.5.1.2	Controls and Displays	3-20
3.5.1.3	Transmitter	3-21
3.5.2	IRCM System Testing	3-21
3.5.2.1	Uninstalled IRCM System Component and System Level Testing	3-21
3.5.2.2	Installed IRCM System Testing	3-22
3.6	Countermeasures Dispensing Systems	3-24
3.6.1	CMDS Components and Operation	3-26
3.6.1.1	Control Unit	3-27
3.6.1.2	Programmer	3-27
3.6.1.3	Sequencer	3-28
3.6.1.4	Dispenser	3-28
3.6.1.5	Expendables	3-28
3.6.2	CMDS Testing	3-30
3.6.2.1	Uninstalled CMDS Testing	3-30
3.6.2.2	Installed CMDS Testing	3-31
3.7	Low Observable Systems	3-32
3.7.1	LO Concepts	3-32
3.7.2	LO Systems T&E	3-33
3.7.2.1	M&S	3-33
3.7.2.2	Signature Measurement	3-34
3.8	Directed Energy Systems	3-35
3.8.1	HPM Systems	3-36
3.8.1.1	HPM System Components and Operation	3-36
3.8.1.2	HPM System T&E	3-36
3.8.2	High Energy Laser Systems	3-38

3.8.2.1	HEL System Components and Operation	3-39
3.8.2.2	HEL Systems T&E	3-39
3.9	References	3-40
3.10	Further Reading	3-41

**Chapter 4 – T&E of EP Techniques** **4-1**

4.1	Introduction	4-1
4.2	EP Techniques and Procedures	4-1
4.3	Testing EP Techniques	4-2
4.3.1	Modelling and Simulation	4-3
4.3.2	Ground Test	4-3
4.3.3	Flight Test	4-3
4.4	ECCM Test Illustration	4-4
4.4.1	Test Objectives	4-4
4.4.2	Pre-Test Analysis	4-4
4.4.3	Test Execution	4-5
4.4.3.1	HITL Testing	4-5
4.4.3.2	ISTF Testing	4-6
4.4.3.3	Flight Test	4-6
4.4.4	Evaluation	4-6
4.5	EP Through Emissions Control Capabilities	4-7
4.5.1	EMCON Concepts	4-7
4.5.2	Testing for Unintentional Emissions and EMCON Capabilities	4-7
4.5.2.1	Ground Tests	4-7
4.5.2.2	Flight Tests	4-7
4.6	References	4-8
4.7	Further Reading	4-8

**Chapter 5 – T&E Aspects of EW System Architecture** **5-1**

5.1	Introduction	5-1
5.2	Standalone EW Systems	5-1
5.2.1	Standalone System Description	5-1
5.2.2	Standalone System Testing	5-1
5.3	Federated EW Systems	5-1
5.3.1	Federated System Description	5-2
5.3.2	Federated System Testing	5-2
5.4	Integrated EW Systems	5-3
5.4.1	Integrated System Description	5-5
5.4.2	Testing Integrated EW Systems	5-5
5.5	References	5-6
5.6	Further Reading	5-6

**Chapter 6 – EW T&E Resources and Facilities** **6-1**

6.1	Introduction	6-1
-----	--------------	-----

6.2	Scope of EW T&E Capabilities	6-1
6.3	Modelling and Simulation	6-3
6.4	Measurement Facilities	6-4
6.5	System Integration Laboratories	6-5
6.6	Hardware-in-the-Loop Facilities	6-7
6.7	Installed System Test Facilities	6-9
6.8	Open Air Ranges	6-12
6.8.1	Introduction to OAR Facilities	6-12
6.8.2	OAR Description	6-14
6.8.3	OAR Uses	6-18
6.8.3.1	Primary Purpose	6-18
6.8.3.2	HITL Testing on the OAR	6-18
6.8.3.3	Correlation of Test Resources	6-18
6.8.3.4	Airborne Testbeds and Flying Laboratories	6-19
6.8.3.5	Threat Simulation Testbeds	6-20
6.8.3.6	Tactics Development and Training	6-20
6.8.4	Benefits and Drawbacks of EW T&E on OARs	6-21
6.8.5	Other EW T&E Resources for OAR Testing Support	6-21
6.9	Distinguishing Factors of Test Facilities	6-23
6.9.1	Number and Fidelity of Players	6-23
6.9.2	Fidelity of Digital Models	6-24
6.9.3	Time, Space and Frequency Resolution and Accuracy	6-24
6.9.4	Signal/Scene Generation	6-25
6.9.5	Instrumentation	6-26
6.9.6	Security	6-26
6.9.7	SUT Support	6-26
6.10	Electromagnetic Compatibility and Interference	6-26
6.10.1	EMC/EMI Tests	6-27
6.10.2	Platform-Level EMC Testing	6-28
6.10.2.1	Intra-System EMC Tests	6-28
6.10.2.2	Inter-System EMC Tests	6-28
6.11	References	6-29
6.12	Further Reading	6-29
<b>Chapter 7 – Modelling and Simulation for EW T&amp;E</b>		<b>7-1</b>
7.1	Introduction	7-1
7.2	Background, Purpose and Definitions	7-2
7.2.1	Background	7-2
7.2.2	Purpose	7-2
7.2.3	Definitions	7-3
7.3	Objectives	7-4
7.4	M&S Categorisation and Levels of Complexity	7-4
7.5	Applying M&S in the EW Test Process	7-7
7.5.1	Defining System Requirements	7-7
7.5.2	M&S in the EW Test Process	7-7

7.6	M&S Activities Supporting EW T&E	7-10
7.6.1	Quantify Test Conditions	7-10
7.6.2	Design Tests	7-11
7.6.3	Predict Test Results	7-11
7.6.4	Simulate Elements	7-11
7.6.5	Quantify Test Results	7-11
7.6.6	Compare Predicted and Test Results	7-11
7.6.7	Extrapolate Test Results	7-12
7.7	Examples of Applying M&S During Test Phases	7-12
7.7.1	MF Example: Antenna Pattern Measurement for Field-of-View MOP Assessment	7-12
7.7.2	SIL Example: Detection Range MOP	7-12
7.7.3	HITL Example: Track Error MOP	7-13
7.7.4	ISTF Example: Pulse Density MOP	7-13
7.7.5	OAR Example: Reduction in Shots MOP	7-14
7.8	Simulation Fidelity, Credibility and Fitness for Purpose	7-14
7.8.1	M&S Fidelity and VV&A – RF Threat Simulation as an Example	7-14
7.8.2	Definitions	7-14
7.8.3	Threat Simulation Fidelity	7-15
7.8.4	Fidelity, Affordability and the Limits of M&S Utility	7-16
7.8.5	Fidelity Description	7-16
7.8.6	M&S Credibility and Fitness for Purpose	7-17
7.8.7	M&S Problems and How Best to Avoid Them	7-19
7.9	NATO Modelling and Simulation Group	7-20
7.9.1	Introduction	7-20
7.9.2	NATO HLA Compliance Certification	7-21
7.9.3	NATO Simulation Resource Library	7-21
7.9.4	NATO M&S Standards Sub-Group: MS3	7-21
7.10	Increased Use of M&S Through-Life	7-21
7.11	References	7-22
7.12	Further Reading	7-23

**Chapter 8 – EW Flight Test Planning, Execution, and Operations** **8-1**

8.1	Introduction	8-1
8.2	Test Planning	8-1
8.3	Flight Test Execution	8-2
8.3.1	Mission Execution Documentation	8-3
8.3.2	Test Mission Participants and Conduct	8-3
8.4	OAR Data Collection	8-5

**Chapter 9 – Learning from Experience** **9-1**

9.1	Introduction	9-1
9.2	Background and Other Sources of Lessons Learned	9-1
9.3	Learning Points Identified	9-1
9.4	References	9-33
9.5	Further Reading	9-33

<b>Annex A – Electronic Warfare T&amp;E Facility Descriptions</b>		<b>A-1</b>
A.1	Introduction	A-1
A.2	Facilities Listing	A-1
A.3	Modelling and Simulation Resources	A-3
A.3.1	Electromagnetic Modelling Group	A-3
A.3.2	Antenna Design and Testing Group	A-5
A.3.3	Cassidian Computational ElectroMagnetics	A-7
A.4	System Integration Laboratory	A-9
A.4.1	Integration Facility for Avionic Systems Testing	A-9
A.4.2	Portable Seeker/Sensor/Signature Evaluation Facility	A-11
A.5	Hardware-In-The-Loop	A-13
A.5.1	ECSEL	A-13
A.6	Installed Systems Test Facilities	A-15
A.6.1	Benefield Anechoic Facility (BAF)	A-15
A.6.2	EW Test Facility (EWTF)	A-18
A.6.3	Air Combat Environment Test and Evaluation Facility (ACETEF)	A-20
A.6.4	Electromagnetic Test Capability	A-22
A.6.5	Anechoic Shielded Chamber	A-24
A.6.6	Electromagnetic Open Area Test Sites	A-26
A.6.7	USAF Joint Pre-Flight Integration of Munitions and Electronic Systems (J-PRIMES)	A-28
A.6.8	CASSIDIAN EME Test Facility	A-30
A.7	Open Air Ranges, Including EW T&E Flight Test Capabilities	A-32
A.7.1	Electronic Combat Range	A-32
A.7.2	Vidsel EW Test Range	A-34
A.7.3	Center for Countermeasures (CCM)	A-36
A.7.4	NATO Joint Electronic Warfare Core Staff	A-38
A.7.5	T&E Support for Aircraft Survivability	A-40
A.7.6	Trials/Test Support Group	A-42
<b>Annex B – Measures Of Performance (MOPs)</b>		<b>B-1</b>
B.1	Introduction	B-1
B.2	Requirements, Objectives, and Measures	B-1
B.3	Measurements	B-1
B.4	MOP Considerations	B-2
B.5	Selected MOPs	B-3
B.5.1	Receiver MOPs	B-3
B.5.1.1	Response Time	B-3
B.5.1.2	Correct Initial Identification Percentage	B-5
B.5.1.3	Correct Beam Correlation Percentage	B-6
B.5.1.4	Correct Mode Change Percentage	B-6
B.5.1.5	Maximum Detection Range	B-6
B.5.1.6	Angle Of Arrival (AOA) Measurement Accuracy	B-6
B.5.1.7	Geolocation Accuracy	B-7
B.5.2	Jammer MOPs	B-7
B.5.2.1	Tracking Errors	B-8

---

B.5.2.2	Cumulative Missile Miss Distances	B-9
B.5.2.3	Reduction in Shot Opportunities	B-10
B.5.2.4	Reduction in Lethality	B-10
B.6	References	B-11
B.7	Further Reading	B-11
 <b>Annex C – Jamming-to-Signal Ratio</b>		<b>C-1</b>
C.1	Introduction	C-1
C.2	J/S for Defensive EA Against a Ground-Based Radar	C-1
C.3	J/S for Offensive EA Against a Ground-Based Radar	C-4
C.4	References	C-5
C.5	Further Reading	C-5
 <b>Annex D – Glossary</b>		<b>D-1</b>
 <b>Annex E – AGARD and RTO Flight Test Instrumentation and Flight Test Techniques Series</b>		<b>E-1</b>
1.	Volumes in the AGARD and RTO Flight Test Instrumentation Series, AGARDograph 160	E-1
2.	Volumes in the AGARD and RTO Flight Test Techniques Series	E-3

# List of Figures

<b>Figure</b>		<b>Page</b>
Figure 1-1	SA-2 GUIDELINE Missile; F-105G Wild Weasel Aircraft with a Shrike ARM	1-4
Figure 1-2	F-117A Nighthawk: The First Operational Low Observable Aircraft	1-5
Figure 1-3	EW Sub-Divisions	1-7
Figure 1-4	EW Suite Architecture Categories	1-8
Figure 1-5	EW Test Resource Categories	1-10
Figure 1-6	The EW T&E Process	1-12
Figure 1-7	Test Design Elements	1-16
Figure 1-8	Types of Decision Error	1-17
Figure 1-9	EW T&E Resource Category Examples	1-19
Figure 1-10	Relative Cost – T&E Resource Utilisation	1-20
Figure 1-11	Relative Use – T&E Resource	1-21
Figure 2-1	Basic EW Receiver Block Diagram	2-1
Figure 2-2	EW Receiver System Types	2-2
Figure 2-3	EW Receiver Elements and Organisational Responsibilities	2-3
Figure 2-4	Typical Radar Warning Receiver Components	2-4
Figure 2-5	Typical RWR/ESM Antenna	2-4
Figure 2-6	Receiver Transmission Line Components and Installed Sensitivity	2-5
Figure 2-7	RWR Components and Functions	2-6
Figure 2-8	RWR Component Locations	2-7
Figure 2-9	Uninstalled RWR Antennas; Installed F-16 RWR Antenna	2-9
Figure 2-10	Representative Azimuth Uninstalled Antenna Gain Pattern Measurements	2-10
Figure 2-11	Typical RWR Manufacturer’s SIL Configuration	2-11
Figure 2-12	Typical Airframe Manufacturer’s SIL Configuration	2-14
Figure 2-13	CV-22 in the Benefield Anechoic Facility, Edwards Air Force Base, California, United States	2-15
Figure 2-14	Flight Test Advantages and Limitations	2-16
Figure 2-15	Simplified MWS Block Diagram	2-21
Figure 2-16	AN/AAR-54 Electronic Unit and Sensors; Aft Missile Warning Sensor Installation on a C-130	2-22
Figure 2-17	Joint Mobile Infrared Countermeasures Test System	2-24
Figure 2-18	Cable Car Test Setup	2-25
Figure 2-19	1223 Laser Warning Receiver System	2-27
Figure 3-1	Electronic Attack System Examples	3-1
Figure 3-2	Types of Noise Jamming	3-4

Figure 3-3	Simplified Jammer Block Diagram	3-4
Figure 3-4	Typical Self-Protection Jammer Components	3-5
Figure 3-5	RF Transmit Path Components and Effective Radiated Power	3-9
Figure 3-6	Example J/S Measurement Technique	3-11
Figure 3-7	Different Types of Support Jamming	3-13
Figure 3-8	EA-6B Aircraft with External Jamming Pods; Miniature Air Launched Decoy Carried by F-16	3-14
Figure 3-9	Effects of Noise and False Target Jamming on PPI Displays	3-14
Figure 3-10	Simple Repeater Towed Decoy Block Diagram	3-16
Figure 3-11	Fibre Optic Towed Decoy Block Diagram	3-16
Figure 3-12	Typical Fibre Optic Towed RF Decoy – AN/ALE-55	3-17
Figure 3-13	AH-1 IRCM Installation and IR Signature Suppressors	3-19
Figure 3-14	Department of the Navy Large Aircraft Infrared Countermeasures Installation on a CH-53E Helicopter	3-19
Figure 3-15	DIRCM Event Sequence	3-20
Figure 3-16	IR-Guided Missile Seeker Mounted on Full Motion Simulator	3-22
Figure 3-17	Joint Mobile IRCM Test System	3-23
Figure 3-18	Typical Chaff Rounds and Chaff Dipoles	3-24
Figure 3-19	Flare Dispensing by F-16 and AC-130U Aircraft	3-25
Figure 3-20	Block Diagram of Countermeasures Dispensing System	3-26
Figure 3-21	Typical CMDS – AN/ALE-47	3-27
Figure 3-22	CMDS with Magazines Installed on a C-130	3-28
Figure 3-23	Examples of Expendable Configurations Within NATO	3-29
Figure 3-24	Flare Testing Using a Cable Car	3-31
Figure 3-25	Airborne Turret IR Measurement System III	3-32
Figure 3-26	F-35 Model Undergoing RCS Measurements	3-34
Figure 3-27	Air-to-Air TIGER Pod Mounted on F-18	3-35
Figure 3-28	Simplified HPM Weapon/Source Block Diagram	3-36
Figure 3-29	The YAL-1 Airborne Laser System	3-38
Figure 3-30	Simplified HEL Weapon/Source Block Diagram	3-39
Figure 4-1	Generic Radar Block Diagram	4-2
Figure 4-2	Areas of Interest	4-5
Figure 5-1	Federated System in HITL Test at ECSEL Facility, Pt. Mugu, California	5-2
Figure 5-2	F-22 Employs a Fully Integrated Avionics and EW Suite	5-4
Figure 5-3	Praetorian Components	5-4
Figure 6-1	Measurement Facility Examples	6-5
Figure 6-2	EW Equipment on Avionics Integration Rig	6-6
Figure 6-3	RF Threat Emitter Simulator and EA/ECM Signal Measurement System	6-7



Figure 6-4	EW HITL Facility Example (1): US Navy EC Systems Evaluation Laboratory	6-8
Figure 6-5	HITL Facility Example (2): UK Dstl Missile Seeker Test Facility	6-9
Figure 6-6	ISTF Example 1: Benefield Anechoic Facility	6-11
Figure 6-7	ISTF Example 2: EW Test Facility	6-12
Figure 6-8	Typical OAR Used for EW T&E – China Lake Electronic Combat Range	6-13
Figure 6-9	Typical Range Threat Simulator – Joint Threat Emitter (JTE)	6-14
Figure 6-10	Examples of Actual Threat Systems used on OAR	6-15
Figure 6-11	Typical Airborne Testbed	6-19
Figure 6-12	NATO JEWCS Training/T&E Capabilities	6-20
Figure 6-13	Examples of Flight Line Testers and Other Equipment for EW T&E	6-22
Figure 6-14	Simulation Fidelity – How Good is Enough?	6-24
Figure 6-15	Quantity of RF Channels per Simulator	6-25
Figure 6-16	Example of RISS Hardware	6-26
Figure 6-17	Typical EMC Testing of EW Equipment	6-27
Figure 6-18	Typical Platform-Level Inter-System EMC Test	6-29
Figure 7-1	M&S Scope: The Electromagnetic Battlespace – Threat Simulation for EW T&E	7-1
Figure 7-2	Activities Within the M&S Interface	7-8
Figure 7-3	M&S Activities at Test Phases	7-9
Figure 7-4	M&S Activities Supporting EW T&E: The DoD LVC Continuum	7-10
Figure 7-5	Increased Use of M&S Through-Life	7-22
Figure 8-1	Typical EW OAR Mission Participants	8-4
Figure 8-2	EW OAR Test Mission Data Sources and Routing	8-6
Figure 9-1	Transmission Efficiency	9-18
Figure 9-2	Radome Ground Return	9-19
Figure B-1	Notional RWR Dwell Structure	B-3
Figure B-2	Response Times	B-4
Figure B-3	Percentile Specification for a Hypothetical RWR (Not Real Data)	B-5
Figure B-4	Geolocation Error Ellipse	B-7
Figure B-5	Sample Median Range Tracking Error Plot	B-9
Figure B-6	Example of a Missile Miss Distance Cumulative Percentage Plot	B-10
Figure C-1	J/S for Defensive EA Against a Ground-Based Radar	C-1
Figure C-2	Jamming and Target Return Signal Power Variation	C-3
Figure C-3	J/S and Burnthrough Range	C-4
Figure C-4	J/S for Offensive EA Against a Ground-Based Radar	C-5

## List of Tables

<b>Table</b>		<b>Page</b>
Table 1-1	System Hierarchy	1-9
Table 1-2	Verification Types and Methods	1-11
Table 2-1	Common Laboratory Measurements on Receivers	2-8
Table 2-2	Summary Comparison of MWS Technologies	2-19
Table 3-1	Radar Types and Performance Characteristics	3-2
Table 6-1	Test Missions by Facility Type	6-2
Table 6-2	Typical M&S Tools Applicable to EW D&D and T&E	6-3
Table 6-3	Cardinal Features of EW Anechoic Chamber Facilities	6-10
Table 6-4	General Features of OARs Used for EW T&E	6-17
Table 6-5	Player Fidelity vs. Test Facility Type	6-23
Table 7-1	M&S Categorisation and Levels of Complexity	7-5
Table 7-2	Threat Simulators and VV&A	7-15
Table 7-3	Top 10 Reasons for M&S 'Unfitness'	7-20
Table 7-4	Ten Commandments of M&S	7-20
Table 9-1	Lessons Learned – An Aid to Problem Recurrence Prevention	9-3
Table B-1	Measurement Scales	B-2

## List of Acronyms and Symbols

1-v-1	1-versus-1
a.k.a.	also known as
AAA	Anti-Aircraft Artillery
AAP	Allied Administrative Publication
AATF	Aircraft Anechoic Test Facility
ABL	Airborne Laser
ABSTIRRS	Airborne Staring Infrared Radiometric System
ACETEF	Air Combat Environment Test & Evaluation Facility
ACMI	Air Combat Maneuvering Instrumentation
ADC	Analogue-to-Digital Converter
Ae	Effective Aperture
AFB	Air Force Base
AGARD	Advisory Group for Aerospace Research and Development
AGL	Above Ground Level
AI	Airborne Interceptor / Avionic Integration
AIDEWS	Advanced Integrated Defensive Electronics System
AM	Amplitude Modulation
AMES	Advanced Multiple Emitter Simulator
AMIRS	Advanced Millimeter Wave Imaging System
Amp	Amplitude, Amplifier
AoA, AOA	Angle-of-Arrival, Analysis of Alternatives
ARM	Anti-Radiation Missiles
ASC	Anechoic Shielded Chamber
ASE	Aircraft Survivability Equipment
ASIL	Advanced System Integration Laboratory
ASIMS	Airborne Spectral Infrared Measurement System
ASTE	Advanced Strategic and Tactical Expendables
ATIMS III	Airborne Turret IR Measurement System III
ATIRCM	Advanced Threat Infrared Countermeasures System
AVGPO	Anti-Velocity Gate Pull Off
AWSEM	Airborne Weapon System Engagement Model
BAF	Benfield Anechoic Facility
BC	Bus Controller
BE	Boundary Element
BEM	Boundary Element Method
BIT	Built-In Test
©	Copyrighted
C&D	Controls and Displays
C3I	Command, Control, Communication, and Intelligence
CAD	Computer-Aided Design
CCM	Center for Countermeasures
CCTV	Closed Circuit Television
CCU	Cockpit Control Unit
CE	Conducted Emissions
CEESIM	Combat Electromagnetic Environment Simulator
CEM	Computational EM Modelling

---

CHAMP	Composite Hard-body And Missile Plume
CIGARS	Calibrated Infrared Ground/Airborne Radiometric System
Cm	Centimeter
CM	Countermeasures
CMDS	Countermeasures Systems
CNI	Communication, Navigation, Identification
COI	Critical Operational Issues
COMINT	Communications Intelligence
COMSEC	Communications Security
CONOPS	Concepts Of Operation
CONSCAN	Conical Scan
CROSSBOW	Construction of a Radar to Operationally Simulate Signals Believed to Originate Worldwide
CRT	Cathode Ray Tube
CS	Conducted Susceptibility
CTP	Critical Technical Parameter
CW	Continuous Wave
D&D	Design and Development
DAP	Data Analysis Plan
DAS	Defensive Aids Suite/System
dB	decibel
dBm	decibel (referenced to a milliWatt)
dBW	decibel (referenced to a Watt)
DE	Directed Energy
Deg	Degrees
DEWSIM	Directed Energy Weapons Simulator
DF	Direction Finding
DIADS	Digital Integrated Air Defence System
DIRCM	Directed Infrared Countermeasures
DOA	Direction Of Arrival
DoD	Department of Defense
DRFM	Digital RF Memory
DRG	Defence Research Group
DSM	Digital Signal Model
DSTL	Defence Science and Technology Laboratory
DT&E	Developmental Test and Evaluation
E3	Electromagnetic Environmental Effects
EA	Electronic Attack
EC	Electronic Combat
ECCM	Electronic Counter Countermeasures
ECM	Electronic Countermeasures
ECR	Electronic Combat Range
ECSEL	EC Systems Evaluation Laboratory
ELINT	Electronic Intelligence
ELS	Emitter Locating System
EM	Electromagnetic
EMC	Electromagnetic Compatibility
EMCON	Emission Control
EMH	Electromagnetic Hazards
EMI	Electromagnetic Interference
EMMLS	Eglin Mobile Missile Launcher System

EMP	Electromagnetic Pulse
EO	Electro-Optical
EP	Electronic Protection
ERP	Effective Radiated Power
ES	EW Support
ESD	Electro-Static Discharge
ESM	Electronic Support Measures
EW	Electronic Warfare
EWC	Electronic Warfare Chamber
EWCC	Electronic Warfare Coordination Cell
EWS	EW Support
EWsT	EW Simulation Technology
EWTF	EW Test Facility
EXCM	Expendable Countermeasures
F	Fahrenheit
FCR	Fire Control Radar
FDTD	Finite Difference Time Domain
FEM	Finite Elements Model
FLIR	Forward Looking Infrared
FMM	Fast Multi-Pole Method
FOTD	Fibre Optic Towed Decoys
ft	Feet
FTEC	Flight Test Editorial Committee
FTTG	Flight Test Techniques Group
FVP	Flight Vehicle integration Panel
G	Gain
GCI	Ground Controlled Intercept
GHz	Gigahertz
G <sub>J</sub>	Antenna Gain (Jammer)
GO	Geometrical Optical
GPS	Global Positioning System
G <sub>R</sub>	Antenna Gain (Radar)
G <sub>R-SL</sub>	Antenna Gain (Radar Sidelobe)
GSE	Ground Support Equipment
GTD/UTD	General and Uniform Theory of Diffraction
GWEF	Guided Weapons Evaluation Facility
HARM	High-Speed Anti-Radiation Missile
HEL	High Energy Laser
HEMP	High-Altitude Electromagnetic Pulse
HF	Hostile Fire
HIRF, HiRF	High Intensity Radiated Field
HITL	Hardware-In-The-Loop
HLA	High Level Architecture
HPM	High-Powered Microwave
HPRF	High Pulse Repetition Frequency
HUD	Head Up Display
IADS	Integrated Air Defence System
IC	Integrated Circuit
IEEE	[US] Institute of Electrical and Electronics Engineers

---

IF	Intermediate Frequency
IFAST	Integration Facility for Avionic Systems Testing
IFM	Instantaneous Frequency Measurement
IR	Infrared
IRCM	Infrared Countermeasures
ISAR	Inverse Synthetic Aperture Radar
ISTAR	Intelligence Surveillance Targeting And Reconnaissance
ISTF	Installed System Test Facilities
J/S	Jamming-to-Signal ratio
JEWCS	[NATO] Joint EW Core Staff
JMITS	Joint Mobile Infrared Countermeasures Test System
J-PRIMES	Joint-Preflight Integration of Munitions and Electronic Systems
JSF	Joint Strike Fighter
JTE	Joint Threat Emitter
kHz	Kilohertz
kW	Kilowatt
L	Loss
LAIRCM	Large Aircraft IR Countermeasures
LEPO	Large Element Physical Optics
LLSC	Low Level Swept Characterisation
LO	Low Observable
LPF	Low Pass Filter
LPRF	Low Pulse Repetition Frequency
LRU	Line Replaceable Unit
LWIR	Long Wavelength IR
LWS	Laser Warning System
m	Meter
M&S	Modelling and Simulation
MALD	Miniature Air-Launched Decoy
MANPADS	Man-Portable Air Defence Systems
MAW	Missile Approach Warners
MC	NATO Military Committee
MC	Mission Computer
MDF	Mission Data Files
MDS	Minimum Discernable Signal
MERAJS	Millimeter Wave Emitters, Radars, and Jamming System
MF	Measurement Facilities
MFD	Multi-Function Display
MFS	Manned Flight Simulation
MG	Missile Guidance
MHz	Megahertz
MIJA	Mobile Intercept Jamming Assets
MLAW	Missile Launch and Approach Warners
MLFMM	Multi-Level Fast Multiple Method
MMI	Man-Machine Interfaces
MMW	Millimeter Wave
MNF	Multi-National Force
MoD	Ministry of Defence
MOE	Measures Of Effectiveness

MoM	Method of Moments
MOP	Measures Of Performance
MOS	Measures Of Suitability
MPRF	Medium Pulse Repetition Frequency
MROCS	Millimeter Wave Obscurant Characterization System
MRV	Mini-Radar Van
MS&SE	Modelling, Simulation and Synthetic Environments
MWIR	Mid-Wavelength IR
MWS	Missile Warning System
NATO	North Atlantic Treaty Organization
NEDB	NATO Emitter Database
NEWVAN	NATO EW Van
NIAG	NATO Industrial Advisory Group
NMSG	NATO Modelling and Simulation Group
NRL	Navy Research Laboratory
NSRL	NATO Simulation Resource Library
OAR	Open Air Range
OCC	Operations Control Center
OE	Operational Effectiveness
OPF	Operational Flight Program
OPSEC	Operational Security
OS	Operational Suitability
OT	Operational Test
OT&E	Operational Test and Evaluation
PC	Personal Computer
PDW	Pulse Descriptor Word
$P_e$	Probability of Effect
PID	Program Introduction Document
$P_J$	Jammer Transmitter Power
$P_k$	Probability of kill
PO	Physical Optical
PPI	Plan Position Indicator
$P_R$	Radar Transmitter Power
PRF	Pulse Repetition Frequency
PRI	Pulse Repetition Intervals
PSI	Platform Systems Integrator
PSSSEF	Portable Seeker/Sensor/Signature Evaluation Facility
PTC	Planned Test Condition
PTD	Physical Theory of Diffraction
PW	Pulse Width
R	Range
R&D	Research and Development
RAM	Radar Absorbent Material
RCIED	Radio-Controlled Improvised Explosive Device
RCS	Radar Cross Section
RE	Radiated Emissions
RF	Radio/Radar Frequency
RFCM	RF Countermeasures System
RiL	Reduction in Lethality

---

RiS	Reduction in Shot Opportunities
RISS	Real-time IR Scene Simulator
RMS	Root Mean Squared
ROE	Rules Of Engagement
RS	Radiated Susceptibility
RTA	Research and Technology Agency
RTB	Research and Technology Board
RTCHAMP	Real Time Composite Hard-body And Missile Plume
RTO	Research and Technology Organisation
RWR	Radar Warning Receiver
SAD	Short-Range Air Defence Site Simulator
SAM	Surface-to-Air Missile
SAR	Synthetic Aperture Radar
SBR	Shooting Bouncing Ray
SCR	Shielded Control Room
SE	Survivability Equipment
Sec	Seconds
SI	System Integration
SIGINT	Signals Intelligence
SIL	Systems Integration Laboratory
SMA	Sub-Miniature A
SMS	Signal Measurement System
SOC	Statement of Capability
SOJ	Stand-Off Jamming, Jammer
SPIRITS	Spectral and In-band Radiometric Imaging of Targets and Scenes
SPJ	Self-Protection Jamming, Jammer
SS	Sub-System
SSA	Solid State Amplifier
SSL	Solid-State Lasers
STANAG	[NATO] STANdardisation AGreement
STEF	Seeker Test & Evaluation Facility
STIRRS	Staring Infrared Radiometric System
STV	Seeker Test Van
SUT	System Under Test
T&E	Test and Evaluation
TC	Test Conductor
TD	Test Director
TEL	Transporter-Erector-Launcher
TGP	Targeting Pod
TIGER	Threat IR Generic Emulation Radiometer
TLM	Transmission Line Method
TM	Telemetry
TRACSVAN (TV)	Transportable Radar and Communications Jamming and Simulation Vans TV
TSPI	Time-Space-Positioning Information
TT	Target Tracking [radar]
TTI	Time To Impact
TWS	Track While Scan
TWTA	Travelling Wave Tube Amplifier
U.K.	United Kingdom
U.S.	United States



---

UAS	Unmanned Aerospace/Autonomous System
UAV	Unmanned Aerospace Vehicle
UCAS, UCAV	Unmanned Combat Air/Autonomous System/Vehicle
USA	United States of America
USAF	United States Air Force
UTD	Uniform Theory of Diffraction
UV	Ultraviolet
V&V	Verification and Validation
VGPO	Velocity Gate Pull-Off
VV&A	Verification, Validation and Accreditation
WPNS	Weapons
WRA	Weapon Replacement Assembly
$\sigma$	Radar cross-section

---

## Author Contact Information

Name: Martin Welch  
Title: Electronic Warfare Technical Expert  
Telephone Number: (661) 277-7461  
Fax Number: (661) 275-5325  
Mailing Address: 771 TS/EWAP  
30 Hoglan Avenue  
Edwards AFB, CA 93524  
USA  
Email: [martin.welch@edwards.af.mil](mailto:martin.welch@edwards.af.mil)

Name: Mike Pywell  
Title: Electronic Warfare Technologist  
Telephone Number: +44-(0)1772-852801  
Fax Number: +44-(0)1772-855262  
Mailing Address: Building W423A (EW Test Facility)  
Warton Aerodrome  
Warton, Preston PR4 1AX  
United Kingdom  
Email: [mike.pywell@baesystems.com](mailto:mike.pywell@baesystems.com)

## **Chapter 1 – INTRODUCTION TO EW TEST AND EVALUATION**

### **1.1 PURPOSE AND SCOPE**

This AGARDograph, which supersedes the original version (Volume 17, Issue 1, 2000), provides an overview of Electronic Warfare (EW) Test and Evaluation (T&E). This Handbook's primary purposes may be stated as:

- To introduce the novice to a disciplined approach to EW testing.
- To provide a concise reference for the EW T&E process and test resources for more experienced testers and programme managers.
- To aid NATO Nations in meeting the affordability challenges facing them. Failure to evaluate installed EW system performance adequately on the ground typically results in significantly increased flight test cost and lengthened schedules.
- To catalogue current T&E resources and capabilities available within NATO Nations (Annex A).

The Handbook offers guidance in applying available resources to meet identified test objectives and to aid cost-effective satisfaction of contractual and operational requirements.

Some caveats apply to this Handbook:

- EW systems and consequently T&E equipment operate in the same technical parameter space, since all operate generally with the same multi-spectral threat environment.
- This Handbook has been predominantly updated by its lead co-authors, who are US and UK EW Specialists. As a result, some unintentional US/UK bias may be detected by the reader. These co-authors are well aware that national variations exist in a number of areas across the Handbook and that differing views exist internationally on the relative importance of items and process elements described therein. The co-authors consider that when taken as a whole, this Handbook is sufficiently robust as a NATO-wide document and that any national differences can be adequately handled by each Nation's EW Experts. The co-authors welcome any comments that readers may have on the Handbook, with a view to inclusion in future updates.
- All system types are covered for EW T&E capabilities, but the concentration is on Radio/Radar Frequency (RF) and Infrared (IR) systems operating in EW frequency ranges.
- No requirement or numeric in the Handbook is intended to be associated with any specific System Under Test (SUT), platform or programme.
- Emitter databases, essential to EW systems and associated T&E equipment, are not discussed since they are nationally sensitive. For the same reason there is limited discussion of Low Observability (a.k.a. 'Stealth' or 'electromagnetic signatures') and directed energy weapons, although, where possible, a fuller discourse on their T&E is provided.
- All images and references to T&E facilities and resources are provided as examples only. They do not indicate that any one facility, resource or equipment is any better than another. Their inclusion in this Handbook does not constitute recommendation by the authors.
- The EW T&E engineer, armed with information in this Handbook, remains responsible for the timely identification, planning and execution of cost-effective tests, using appropriate facilities and resources, in order to satisfy their programme's requirements.

### 1.2 BACKGROUND

Developing and fielding modern EW systems is complex, expensive, and requires a disciplined test approach to ensure that limited programme resources are prudently applied. Therefore, an EW T&E professional's most important task is to determine the appropriate test objectives to satisfy the acquisition programme requirements. All acquisition programmes have milestones where system performance must be evaluated to determine if the system is ready to proceed to the next phase. Decision makers need timely and accurate information about the SUT. Test programmes should be structured such that they provide decision-quality information incrementally throughout the life of the test programme. This allows for system deficiencies to be identified early in the programme when the costs to resolve them are relatively low.

The scope of EW test programmes can vary greatly and it is the task of the EW T&E professional to construct a test programme to cost-effectively meet the programme needs. There are a wide variety of test resources and techniques available to accomplish this. A simple programme might entail taking a radar warning receiver of the type that has been previously proven on a fighter platform and re-hosting it on a transport aircraft. At the other end of the spectrum are programmes with several new EW systems operating as an integrated suite on a platform that is itself networked with other systems. In both cases, the EW T&E professional's task is to tailor a programme that tests the right things at the right time using the right resources.

This Handbook also provides a useful directory of key EW T&E resources available to NATO members, and examines lessons of the past which can be used to improve the productivity of future testing. While much of the content is aimed at personnel with relatively little experience in the field of EW T&E, this volume can also serve as a basic checklist of issues to be covered in planning, conducting, and evaluating EW tests. In order to gain an appreciation for current practices in EW T&E, some discussion of the history of EW system development, EW system application in modern warfare, and generic elements of disciplined testing are presented in this introduction.

With the rapid evolution of military electronics and computer science, the range, complexity, and sophistication of EW systems has grown significantly. This Handbook focuses on testing avionics systems for military aircraft, the primary purpose of which is Electronic Countermeasures (ECM) and Counter-Countermeasures (ECCM). This testing has much in common with the testing of any avionics system, especially in those areas that relate to availability, operability, supportability, and reliability.

### 1.3 HISTORY OF EW

Many would argue that EW dates back to the Crimean War and American Civil War and the advent of the telegraph as an important form of military communications. Early EW techniques included interruption of the enemy's communications by cutting the telegraph lines, and deceiving the recipients by sending misleading messages. These processes are similar to the current concept of Electronic Attack (EA). Listening in on the enemy's transmissions by tapping the telegraph lines may be the earliest form of EW Support (ES). While no radiated Electromagnetic (EM) energy was involved at this point, the rudimentary concepts of attacking, protecting, and exploiting electronic communications had begun. [1]

The pursuit of EW in military aviation first began in earnest during World War II. Radio beams were used to guide bombers to their targets; radar was used to detect and locate enemy aircraft; and radio communication was becoming the primary means of establishing command and control. As each new electronic measure was employed, the adversary developed a countermeasure or EA capability. In many instances, in order to preserve the advantage of the initial electronic measure in the face of countermeasures, counter-countermeasures or Electronic Protection (EP) were developed. [2]

One of the most significant EW events during World War II and one that highlights EW's role as a force multiplier was the first use of 'Window' by the British during a bombing raid on Hamburg in July 1943.

'Window' was the code name for an early version of chaff. The British had been encountering heavy losses from radar-directed German anti-aircraft guns and night fighters. The use of 'Window' totally surprised the Germans and completely disrupted the German gun direction and fighter control radars resulting in significantly reduced losses and the near complete destruction of Hamburg. [3]

The Vietnam War, with the backdrop of the Cold War, presented the next major flurry of EW activity. The North Vietnamese employed a Soviet-style Integrated Air Defence System (IADS). Throughout the war the North Vietnamese continued to upgrade the IADS and correspondingly the U.S. adapted to the upgrades with new countermeasures. While strategic bomber and reconnaissance aircraft have long used EW equipment such as Radar Warning Receivers (RWR) and Self-Protection Jammers (SPJ), Vietnam led to widespread use of these systems on tactical aircraft. The conflict also led to the development of specialised aircraft known as Wild Weasels to suppress enemy Surface-to-Air Missile (SAM) radars. The Wild Weasels employed sophisticated EW receivers and Anti-Radiation Missiles (ARMs) to accomplish their mission. Figure 1-1 shows an SA-2 Guideline missile of the type commonly used in Vietnam and an F-105G Wild Weasel aircraft. This era marked the beginning of modern requirements for survival in the presence of electronically-directed enemy fire control. [4]



**Figure 1-1: SA-2 GUIDELINE Missile (top); F-105G Wild Weasel Aircraft with a Shrike ARM (bottom) – (U.S. DoD and USAF Photos).**



The Arab-Israeli War in October 1973 provides a good illustration of what happens when the air defence threat posed by one adversary advances beyond the EW capabilities of the other. The war “lasted less than a month, yet it contained all the elements of a much longer war. It was an intense, bitterly contested conflict with each side well-equipped with the weapons for modern warfare. The Egyptian and Syrian air defences at that time, were developed from Soviet design. The design stressed overlapping networks of SAM and Anti-Aircraft Artillery (AAA) coverage. This formidable air defence network consisted of the SA-2, SA-3, SA-6, SA-7, the ZSU-23-4, and other AAA systems. While there were proven ECM from the Vietnam War for the SA-2 and SA-3 and IR countermeasures, such as flares for the SA-7, the SA-6 proved to be a surprise. The SA-6’s radars operated in a portion of the electromagnetic spectrum never used before by the Soviets. The Israelis tried to compensate for their lack of ECM against the SA-6 by flying lower, trying to get under its radar coverage. This tactic placed them into the heart of the ZSU-23-4 threat envelope and contributed to the loss of numerous aircraft. This forced the Israelis to adjust their electronic equipment, modify their tactics, and seek additional ECM equipment, such as ECM pods and chaff dispensers from the U.S. However, before the tactics were changed and the new equipment arrived, the Israelis suffered heavy aircraft losses, which taught them a valuable lesson.” [5]

The 1970s and 1980s also saw the coming of age of Low Observable (LO) technology. While LO principles have been applied earlier, the F-117A development marked the first time that LO principles would be the dominant design attribute for an aircraft. The F-117A, shown in Figure 1-2, became operational in 1985 and played a key role in Operation Desert Storm, where it operated with impunity in heavily defended airspace. Since the F-117A debut, LO technology has become an important consideration for all combat aircraft. [6]



**Figure 1-2: F-117A Nighthawk: The First Operational Low Observable Aircraft – (U.S. DoD Photo).**

Operation Desert Storm (1991) was spearheaded by an effort to suppress and destroy the Iraqi Kari IADS. This effort brought together all aspects of EW. Air-launched decoys deceived the Iraqi IADS into engaging them with radar-directed SAM systems such that Wild Weasel aircraft could target them with

High-speed ARMs (HARM). Support jamming aircraft jammed surveillance radars. F-117A aircraft attacked and destroyed key Command, Control, and Communications (C3) centres supporting the IADS. This initial coordinated EW activity was crucial to success of the ensuing coalition air campaign. [7]

Much of the historical EW perspective is still relevant to the modern electronic battlefield. What have changed are the speed, engagement range, communications network robustness, and lethality of the modern threat. The EW community must stay abreast of developments in the threat environment to ensure that aircrew do not face the type of surprises that the Israelis faced in 1973.

## **1.4 EW DEFINITIONS AND SYSTEM CLASSIFICATION**

This section defines EW and related terms and describes the different classifications of EW suite architecture.

### **1.4.1 EW and Related Definitions**

The definition of EW is broadly the same internationally, although EW components' definitions differ between NATO and some of its member and partner Nations. EW is defined in NATO as: 'Military action to exploit the electromagnetic spectrum encompassing: the search for, interception and identification of electromagnetic emissions, the employment of electromagnetic energy, including directed energy, to reduce or prevent hostile use of the electromagnetic spectrum, and actions to ensure its effective use by friendly forces.' [8]

The definition of EW does not make any reference to the equipment used, but rather is confined to a description of the task or mission. For the most part, the equipment used specifically in the accomplishment of EW is avionics. This relationship between EW and avionics establishes the domain of EW T&E in the aerospace environment. Testing and evaluating EW systems requires the application of the skills and insights requisite of testing avionics equipment in general, tempered with a view of the military actions to be accomplished using these devices. The functionality and military worth of EW systems is highly role, mission, and scenario dependent.

The U.S. Chairman of the Joint Chiefs of Staff, Joint Publication (JP) 3-13.1 addresses EW operational applications and also considers multi-national EW coordination. This document notes that while "'NATO Electronic Warfare policy' is largely based on US EW policy, the perspective and procedures of a Multi-National Force (MNF) EW Coordination Cell (EWCC) will be new to most." [9] The reader is referred to the NATO documents: Military Committee document 64/9 and STANAG 6018, both Restricted documents, for further information regarding NATO definitions of EW and its components. [10],[11]. The U.S. definitions will be used throughout this document unless otherwise stated.

In the NATO and U.S. Joint lexicon, EW has three sub-divisions: EA, EP, and ES. While minor national variations exist across NATO and its partner Nations, this lexicon has typical definitions:

- Electronic Attack (EA) – The use of electromagnetic energy, DE, or anti-radiation weapons to attack personnel, facilities, or equipment with the intent of degrading, neutralising or destroying enemy combat capability and is considered a form of fires. [12]
- Electronic Protection (EP) – Actions taken to protect personnel, facilities, and equipment from any effects of friendly or enemy use of electromagnetic spectrum that degrade, neutralise, or destroy friendly combat capability. [13] EP is also known as ED, Electronic Defence.
- Electronic Warfare Support (ES) – Actions taken by, or under direct control, of an operational commander to search for, intercept, identify and locate, or localise sources of intentional and unintentional radiated electromagnetic energy for the purpose of immediate threat recognition, targeting, planning, and conduct of future operations. [13]



Figure 1-3 shows the three EW sub-divisions and identifies some specific applications.

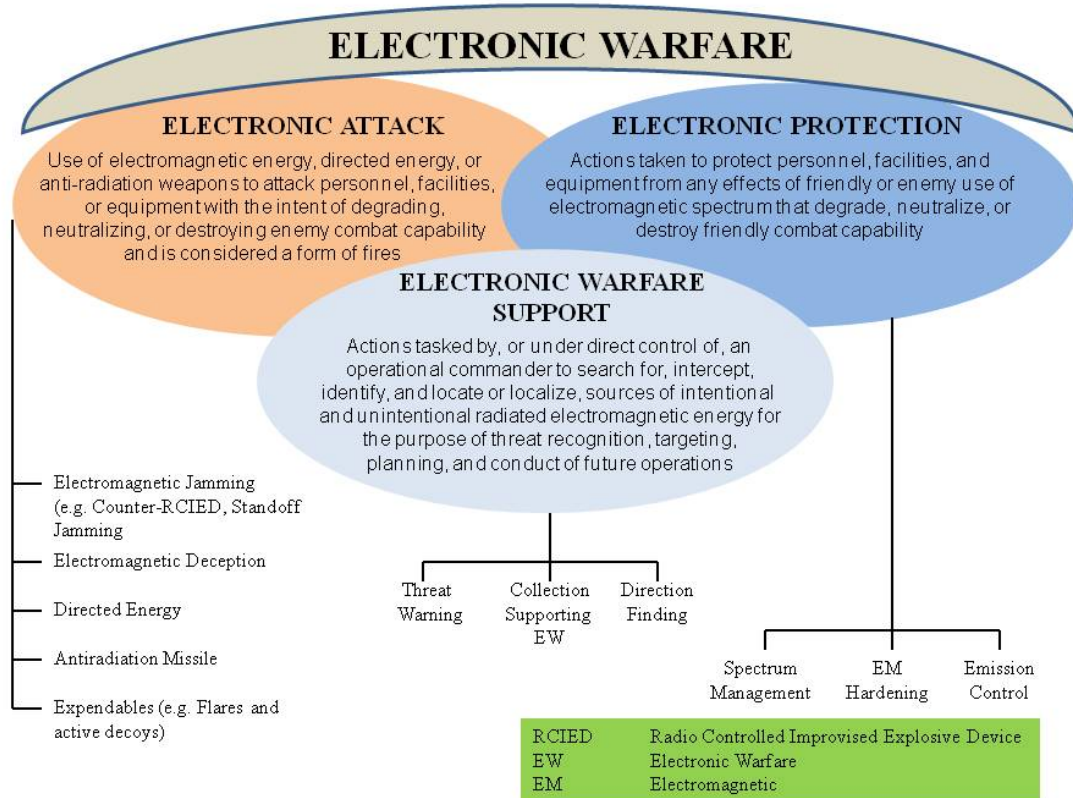

Figure 1-3: EW Sub-Divisions.

Electronic Intelligence (ELINT), Signals Intelligence (SIGINT), and Communications Intelligence (COMINT) have many similarities to ES. They are defined as:

- ELINT – Technical and geolocation intelligence derived from foreign non-communications electromagnetic radiations emanating from other than nuclear detonations or radioactive sources. [14]
- SIGINT – A category of intelligence comprising either individually or in combination all communications intelligence, electronic intelligence, and foreign instrumentation signals intelligence, however transmitted or intelligence derived from communications, electronic, and foreign instrumentation signals. [15]
- COMINT – Technical information and intelligence derived from foreign communications by other than the intended recipients. [16]

These mission areas are not considered EW under the US definition. However, the systems that perform these mission areas are functionally similar to ES systems and much of the information about ES systems and ES systems T&E in this Handbook applies to them as well.

### 1.4.2 EW System Architecture Classifications

There are a variety of EW system architectures in use, so it is difficult to separate them into neatly defined categories. Three general classifications, illustrated in Figure 1-4, will be used in this Handbook:

- **Stand Alone** – Each discrete EW system operates independently or nearly independently of every other EW system.

## INTRODUCTION TO EW TEST AND EVALUATION

- Federated** – Each EW system largely maintains its functional boundaries. The individual EW systems commonly share data via an EW data bus with the RWR serving as the bus controller. The individual EW systems also communicate via the avionics data bus to receive inputs such as aircraft attitude and flight data and to provide status information to the avionics system. The shared data also aids RF management; for example, the Fire Control Radar (FCR) can provide its operating characteristics such that the RWR and jammer will not process it as a threat.
- Integrated** – All EW components, as well as other avionics systems, share common processing resources and databases. Data fusion algorithms are commonly used to enhance the information quality. Integrated systems can also schedule other aircraft system apertures and sensors to perform EW tasks, for example the FCR antenna is a high gain aperture capable of supporting secondary tasks. All controls and display information is routed by the central processor.

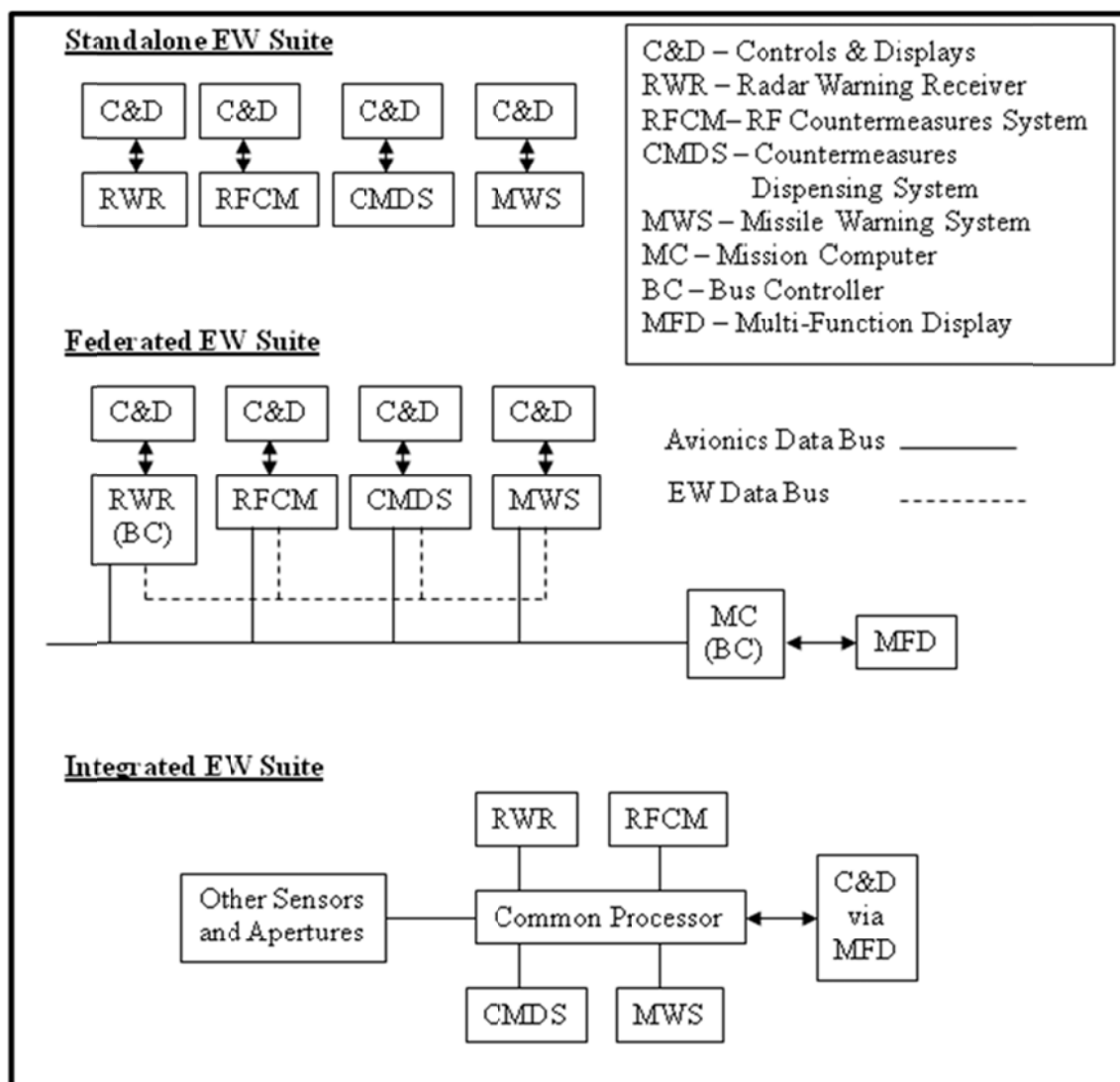

Figure 1-4: EW Suite Architecture Categories.

### 1.4.3 System Hierarchy

A weapon system is comprised of a number of elements. Table 1-1 identifies the individual elements and how they build up to form an entire weapon system.

**Table 1-1: System Hierarchy.**

Element	Description	Examples
Component	Constituent part of an LRU	<ul style="list-style-type: none"> <li>• Circuit card assemblies</li> </ul>
Line Replaceable Unit (LRU) also known as Weapon Replacement Assembly (WRA) or Module Replaceable Unit	An essential support item removed and replaced at field level to restore an end item to an operationally ready condition.	<ul style="list-style-type: none"> <li>• RWR receiver assembly</li> <li>• RWR signal processor</li> <li>• RFCM transmitter</li> </ul>
Equipment	A complete and functionally discrete piece of equipment	<ul style="list-style-type: none"> <li>• RWR</li> <li>• RFCM System</li> <li>• MWS</li> <li>• CMDS</li> </ul>
Sub-System	Comprised of the various equipments	<ul style="list-style-type: none"> <li>• Defensive Aids Sub-System</li> <li>• Navigation Sub-System</li> </ul>
System	Comprised of the various sub-systems	<ul style="list-style-type: none"> <li>• Avionics System</li> <li>• Propulsion System</li> </ul>
Weapon System	Comprised of the various systems	<ul style="list-style-type: none"> <li>• Complete Aircraft</li> </ul>

## 1.5 TEST RESOURCE CATEGORIES

EW system testing spans an enormous range starting with inspection of components and materials to be used in the manufacture of systems, and culminating with in-service support, including mission data and countermeasures validation and optimisation, problem investigation, and failure diagnosis. This Handbook concentrates on testing used to assess the capability of an EW system to comply with system-level specifications, perform its intended military role, and its potential to be serviceable and supportable in the field. These qualities are generally assessed using a combination of flight- and ground-based tests and employ a wide range of test resources.

Test resource categories applicable to EW testing include Measurement Facilities (MFs), System Integration Laboratories (SILs), Hardware-In-The-Loop (HITL) facilities, Installed System Test Facilities (ISTFs), and Open Air Ranges (OARs). A sixth resource category is Modelling and Simulation (M&S). See Figure 1-5.

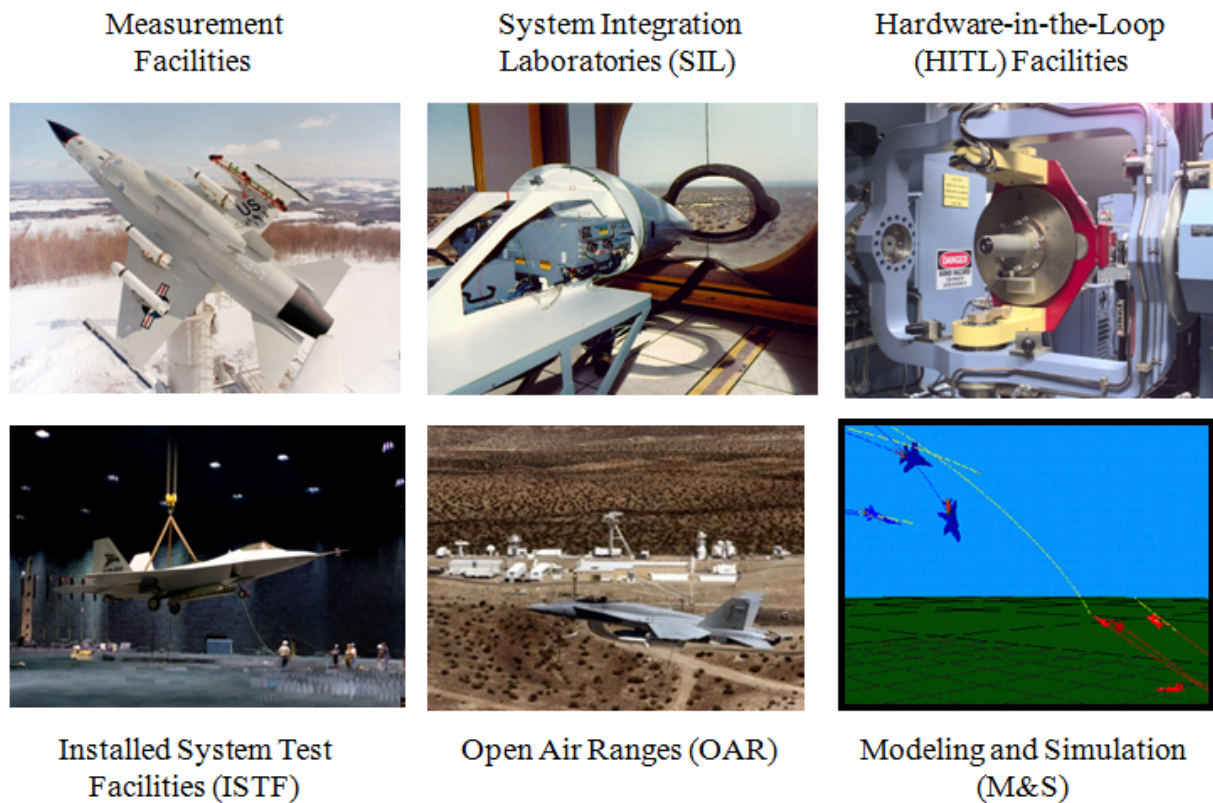

**Figure 1-5: EW Test Resource Categories – (U.S. DoD Images).**

It is tempting to equate ‘types of tests’ with specific test facilities. For instance, OARs provide an environment where aircraft can be operated in their intended flight regimes, and can often support testing of systems installed in the aircraft while the vehicle is on the ground. In this scenario, an ‘installed system’ type of test using an OAR resource category would be conducted.

Large anechoic chambers, capable of holding an actual aircraft, are frequently classed as Installed System Test Facilities. While this categorisation is applicable, it does not convey the full range of applications for which an ISTF may be suitable. Frequently, ISTFs are used to support HITL tests, integration activities, and simulations. If the resource category description is used to define the test types that the resource can support, there is a risk of inaccurate or incomplete understandings of the T&E value of many test resources.

This Handbook will use the term Test Resource Category to identify the primary role of a specific test facility and will use Test Type to reference the various levels of testing and system integration that may be accommodated at a given facility.

**1.6 THE ACCEPTANCE PROCESS AND TYPES OF TEST**

EW equipment manufacturers and Platform Systems Integrators (PSI) must ultimately prove that their system or systems meet the contractual specification requirements. The details of the process vary by country; however there are some common elements. The contractual requirements are typically tabulated in a matrix identifying the particular requirement, the acceptance method, and the venue for the activity. Table 1-2 identifies and defines the type of verification and the methods. [17]

Table 1-2: Verification Types and Methods.

TYPE	METHOD
Inspection	<ul style="list-style-type: none"> <li>• Physical inspection, visual verification</li> <li>• Document review</li> <li>• Read-across by analogy, where prior evidence alone is used to fulfil a requirement</li> </ul>
Analysis	<ul style="list-style-type: none"> <li>• M&amp;S, e.g., mathematical, statistical, physical</li> <li>• Read-across by evaluation, where prior evidence is used to partly fulfil a requirement</li> <li>• Technical evaluation of equations, charts, reduced and/or representative data</li> </ul>
Test	<ul style="list-style-type: none"> <li>• Laboratory – software test, rig test (by equipment manufacturer/supplier) and rig test (by manufacturer/supplier or Platform Systems Integrator – PSI)</li> <li>• Anechoic chamber (specialist equipment)</li> <li>• Aircraft ground test, e.g., Electromagnetic Compatibility and Interference (EMC/EMI)</li> <li>• Flight test – local or dedicated EW range</li> </ul>
Demonstration	<ul style="list-style-type: none"> <li>• Un-instrumented rig or aircraft test where requirement is met by observation alone</li> </ul>

There is a hierarchy of test types which must take place in order to quantify the overall performance of the SUT. This sequence of T&E events tends to mirror the overall maturing of the SUT as it progresses through the development process.

Figure 1-6 depicts this process and helps to characterise an important attribute of the test process. It is a purposefully recursive process that continually refines the estimated performance of the SUT as it reaches higher levels of integration and maturity. Such a deliberate process may be difficult or even impossible to achieve due to fiscal, schedule, or test facility constraints. Each of the desired test events represents an opportunity to help reduce risk in developing the EW system. Here is where the tester’s experience and application of statistically sound methods can construct a test programme that optimises the use of test resources while meeting budget and schedule constraints. Ultimately, the tester provides decision makers with quantifiable information about programme technical risks.



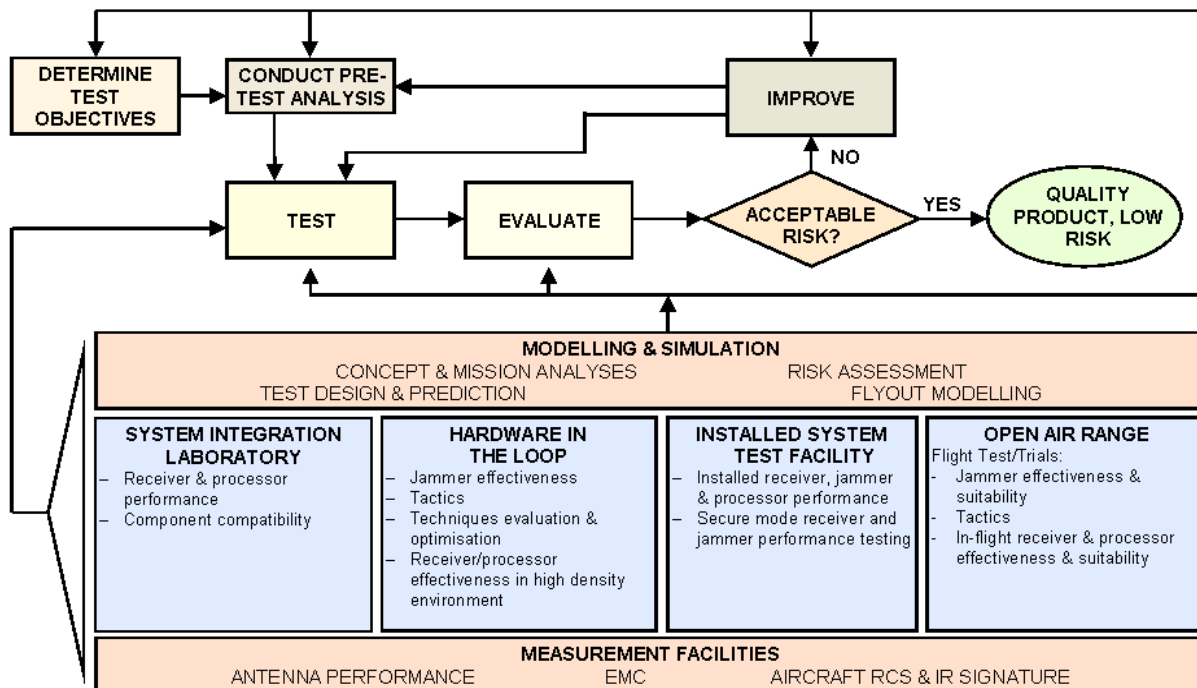

Figure 1-6: The EW T&E Process.

Some of the choices may not be obvious. For instance, flight testing is generally considered to be a more complete test than those events accomplished in an HITL or ISTF. The experienced tester, however, may determine that due to limitations of threat simulators available on the OAR, he can actually create a more realistic test scenario in an ISTF. This particular type of choice is frequently encountered when testing the effects of high threat or signal density. Most OARs are very limited in the quantity of threat simulators they can provide. On the other hand, HITLs and ISTFs can most often simulate very large numbers of threat signals with adequate fidelity.

## 1.7 EW SYSTEM APPLICATION IN WARFARE

As discussed earlier in this section, EW can be broken down into three primary divisions: EA, EP, and ES. While it is not the intent of this Handbook to fully describe the role of EW in military operations or to provide a detailed analysis of specific EW techniques, a brief overview of each of these primary divisions is given below to underpin a better understanding of the test requirements.

### 1.7.1 Overview of EA

EA is the use of electromagnetic or directed energy to attack personnel, facilities, or equipment. There are five basic sub-divisions of EA: jamming, deception, DE, ARM, and expendables. Jamming is generally defined as deliberate radiation, re-radiation, or reflection of energy for the purpose of preventing or reducing an enemy’s effective use of the electromagnetic spectrum. With recent advances in technology and more frequent use of spectra outside the RF range, this definition can be extended to cover similar action against IR, Ultraviolet (UV), and electro-optical systems.

Jamming is the most prevalent form of EA and has two major sub-divisions: self-protection and support. In self-protection jamming, also known as defensive EA, the same vehicle being targeted by the enemy radar or sensor system carries the EA system. Support jamming, also known as offensive EA, has three sub-categories: stand-off, stand-in, and escort. In stand-off jamming, the EA platform normally operates

beyond the engagement range of the enemy air defence system and jams the surveillance elements of the air defence system in support of other attacking aircraft. Stand-in jamming is similarly directed at the surveillance elements of an enemy air defence system, but operates within the range of enemy air defence weapons. Stand-in jamming is normally performed by Unmanned Air Systems (UAS)<sup>1</sup>. In escort jamming, the jamming aircraft accompanies the strike package it is charged with protecting. This means that the escort jamming aircraft must have performance and range similar to the strike aircraft.

There are basically two types of enemy radar that must be jammed by EA:

- Surveillance radars perform two basic functions in an IADS: early warning, which provides overall situational awareness for forming the air picture, and target acquisition for terminal threat systems.
- Radars associated with the terminal threat systems, typically those performing target tracking and missile guidance. Terminal threat radars are usually given high priority in the hierarchy of EA threats because they are associated with the lethal phases of a weapon guidance system.

EA jamming techniques are used to disrupt or break the threat's range, velocity, or angle tracking capability and force the threat system to re-acquire the target and re-aim the weapon – a process which could provide the target the time to pass harmlessly through the threat's engagement envelope.

EM deception is the deliberate radiation, re-radiation, alteration, suppression, absorption, denial enhancement, or reflection, of EM energy in a manner intended to convey misleading information to an enemy or to an enemy's EM-dependent weapons, thereby degrading or neutralising the enemy's combat capability.

DE is an umbrella term covering technologies that relate to the production of a beam of concentrated electromagnetic energy or atomic or sub-atomic particles. The two most common manifestations of DE are High-Energy Lasers (HELs) and High-Power Microwave (HPM) devices.

ARMs are designed to home on RF emissions from enemy radar systems. These missiles aim to either destroy the targeted radar system or at least force it to cease operating to avoid destruction. These air-launched weapons normally receive targeting information from ES receiver systems on board the host platform. It is beyond the scope of this Handbook, but it is important to realise that these and other weapons systems are increasingly able to tap into networked systems that can provide targeting information from other sources via data links.

Expendable countermeasures are deployed from a host platform and normally perform self-protection functions. The three most common expendable countermeasures types are chaff, flares, and towed decoys. Chaff can be employed against search radars or as self protection against Target-Tracking Radars (TTRs) and missile guidance radars. Chaff is dispensed in bundles composed of many thousands of very thin conductive elements designed to reflect RF energy and confuse the victim radar. Flares are designed to protect aircraft from IR-directed threat systems by providing a more attractive target to the missile seeker than the targeted aircraft. Towed decoys attempt to provide the threat system a more attractive target than the platform they protect.

In addition to the above elements of EA, Emission Control (EMCON)<sup>2</sup>, and Low Observable (LO) techniques are considered passive forms of EA. [18]

---

<sup>1</sup> UAS, which also means Unmanned *Autonomous* Systems, include UAVs (Unmanned Aerospace Vehicles) and UCAVs (Unmanned Combat Air Vehicles).

<sup>2</sup> EMCN is according to some sources a form of EP and will be treated as EP for the remainder of this handbook. [18]

### **1.7.2 Overview of EP**

EP is that action taken to negate the effects of either enemy or friendly EA that would degrade, neutralise, or destroy friendly combat capability. EP techniques tend to be the result of developments of EA capabilities. Most EP techniques are defined in relation to how they counter a specific EA threat. Usually, the EP technique is some improvement in the sensor system design that counteracts the effect of a specific EA technique; therefore, it is difficult to understand the purpose of a specific EP technique without knowing the EA technique that it is designed to counteract. EMCON is also a form of EP. [19]

Usually, the design requirements of a system that operates in a jamming environment will exceed the requirements of a similar system designed to operate only in a friendly environment. For example, a radar receiver designed for use in a civilian environment can tolerate relatively wideband frequency response with only minimal degradation in performance. A similar receiver designed for use in a jamming environment would require narrowband frequency response to prevent skirt jamming.

The EP designer may utilise sophisticated transmitted waveforms and receiver processing that will make deception jamming difficult. This forces the enemy to use high-power, brute-force noise jamming. The EP designer can then use frequency hopping or multiple simultaneously transmitted frequencies so that the enemy must broaden the bandwidth of his jamming. This causes the enemy jammer to diffuse its energy over a wide bandwidth, thus reducing the effectiveness of the EA. A true, never-ending cat-and-mouse game between EA and EP designers then follows.

### **1.7.3 Overview of ES**

ES is that division of EW concerned with the ability to search for, intercept, identify, and locate sources of radiated electromagnetic energy. ES is used in support of tactical operations for situational awareness, threat avoidance, homing, and targeting. Onboard radar warning and missile warning receivers, as well as many off-board surveillance systems, are considered elements of ES.

## **1.8 THE EW T&E PROCESS**

The EW test process, as depicted in Figure 1-6, requires a disciplined approach to ensure that the required testing is accomplished in a timely and cost-effective manner that ultimately provides acquisition programme decision makers with accurate information about the SUT. The most important part of a test programme is determining the test objectives. The test objectives get to the heart of what is to be accomplished and thereby determine the direction and scope of the programme. If the test team doesn't get the objective right, the programme runs a significant risk of not generating the necessary information to support programmatic decision making. The test objectives need to be coordinated between programme management and the test team to ensure that all participants understand the relationship between the financial resources available and the quality of information provided. A vital role of professional testers is to convey risk assessments to programme managers when financial resources are constrained and advise them on options.

### **1.8.1 Test Objectives**

Test objectives derive from two basic sources: documented operational requirements of the military end user and contractual specification requirements. Ideally, these would be identical, but they sometimes differ in practice. The system programme office charged with acquiring the weapons system typically contracts with the manufacturer to provide specific quantifiable data about the performance of the acquired system. Test professionals representing the government generally participate in the Developmental Test and Evaluation (DT&E) phase to provide the programme office with an independent evaluation of the weapons system's performance relative to specification requirements. DT&E is defined as any testing used to assist in



the development and maturation of products, product elements, or manufacturing or support processes. It is also any engineering-type test used to verify status of technical progress, verify that design risks are minimised, substantiate achievement of contract technical performance, and certify readiness for initial Operational Testing (OT). Development tests generally require instrumentation and measurements and are accomplished by engineers, technicians, or soldier operator-maintainer test personnel in a controlled environment to facilitate failure analysis. [20]

Additionally, the DT&E community must address military utility aspects of the SUT performance that are not addressed by the specification requirements. The role of DT&E above and beyond specification compliance assessments reduces the risk of finding problems in Operational Test and Evaluation (OT&E) that could preclude fielding the weapon system.

OT&E is the field test, under realistic conditions, of any item (or key component) of weapons, equipment, or munitions for the purpose of determining the effectiveness and suitability of the weapons, equipment, or munitions for use in combat by typical military users; and the evaluation of the results of such tests. [21] Test programmes that coordinate DT&E and OT&E throughout the programme's life greatly enhance their chance of successfully completing OT&E and fielding the weapons system.

Large acquisition programmes typically have a hierarchy of test objectives. A large programme charged with acquiring a new airframe that employs a number of potentially integrated sub-systems might have as an overall test objective: "Evaluate the performance of the F-XX aircraft". It could then have subordinate level test objectives such as: "Evaluate the defensive avionics suite", or "Evaluate the fire control radar system", etc. Further, an objective to evaluate the EW systems of an aircraft could be broken down into its components: "Evaluate the RWR performance", "Evaluate the expendable countermeasures system", etc. A small programme might have only a single stand alone objective, such as "Evaluate the performance of a new countermeasures flare". In any event, it is important that the EW tester be aware of how test objectives fit into the overall test programme.

### **1.8.2 Test Design**

The DT&E test designers must ensure that two questions are answered. First, the test must determine if the manufacturer has met each of the contractual specification requirements. Second, the system must be evaluated to determine if the military utility is adequate to proceed to dedicated OT&E. It is possible for a system to meet all specification requirements but have sufficient military utility deficiencies to preclude a release to begin dedicated OT&E. OT&E testing is conducted under operationally realistic conditions to determine if the system is effective and suitable.

Figure 1-7 shows the main elements of test design. The programme objectives address both the specification compliance and the military utility and once they have been established, the test team must determine the measures by which the system performance or effectiveness will be evaluated. These are known as Measures Of Performance (MOPs) and Measures Of Effectiveness (MOEs). The MOPs are generally more applicable to DT&E and are generally tied directly to contractual technical performance requirements while MOEs apply to OT&E. This Handbook primarily addresses DT&E and will use the term MOP generically when discussing performance measures.

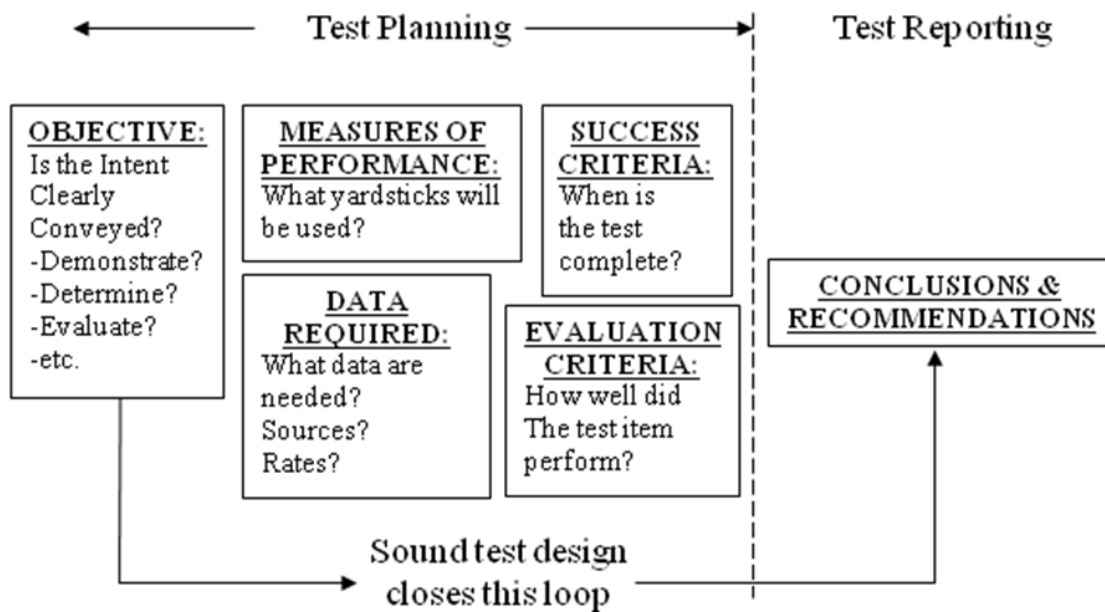

Figure 1-7: Test Design Elements.

The objectives must be testable, that is, the selected MOPs must be quantifiable attributes of the system that directly relate to operationally relevant functions. A specific type of MOP is the Critical Technical Parameter (CTP); the CTPs are parameters deemed vital to the desired capability of the weapon system. Two examples for an RWR include response time which relates directly to the warning time the system will provide the aircrew or angle of arrival measurement error which relates to the quality of the warning information provided. Note that MOPs are always nouns: time, error, etc.

Annex B discusses some common MOPs, to assist understanding measurements and what information they convey. It is intended to make the reader think about what details need to be addressed and documented in the planning stages, to avoid disagreements later in the programme when they are generally more difficult and costly to resolve.

System acquisition programme managers should involve experienced testers early in the system specification or contractual requirements development process. Experienced testers know what system attributes are meaningful, testable, and measurable. If a system attribute cannot be quantified or quantified in a useful manner, it is worthless.

Once the test objectives have been established and the MOPs identified, the amount of data required must be determined in order to estimate the values of the MOPs. This is critically important to programme managers because the amount will dictate the length and cost of the test programme.

Even the best designed tests only yield estimates of the true values of the SUT's measures of performance. MOPs are random variables generated from finite data samples. Therefore, it is impossible to establish the true value of a given MOP. A typical test will produce an estimate of the average value of an MOP, i.e., the mean or median and spread of the data, commonly expressed as the variance or the standard deviation. This means that each time a data set is collected it will produce a different result.

Many EW performance specifications are based on whether or not the estimated value of a MOP, such as response time, meets a required value. Even a well-conceived and executed test can result in a spread of the data collected. This implies that occasionally the estimated value will be sufficiently in error that the wrong conclusion about the system's performance may be drawn.

A key role that T&E professionals play on the acquisition team is to quantify the risk of such an error occurring and communicating that information to the decision makers prior to the test. This will ensure that decision makers understand the relationship between the resources expended and the quality of the answers that will be provided and ultimately the risk they will be accepting.

For example, if the response time contractual specification requirement for an RWR against a given threat radar beam is X seconds, the test team needs to design a test procedure to test the hypothesis that the system meets the specification requirement; the null hypothesis is that the system response time is less than or equal to X seconds. The hypothesis test can have four possible outcomes as shown in Figure 1-8.

		True (Unknown) State of SUT	
		System Meets Specification Requirement	System Does Not Meet Specification Requirement
Programmatic Decision	System Does Not Meet Requirements	Type I error – Rejected a Good System	Correct Decision
	System Meets Requirements	Correct Decision	Type II error – Passed a Bad System

Figure 1-8: Types of Decision Error.

Basically, a Type I error occurs when a ‘good’ system is incorrectly rejected for failing to meet the performance specification requirement and a Type II error occurs when a ‘bad’ system is incorrectly accepted as having met the performance specification requirement. There are many excellent references on the statistical techniques of determining probabilities. A typical approach is to specify the probability of a Type I error (the significance level of the test) and design the test procedure such that the probability of incurring a Type II error is acceptably small (this determines the power of the test). [22] Generally, the likelihood of incurring Type I or Type II errors can be reduced by increasing the sample size. Experimental design techniques can optimise the quality of information provided for given cost and schedule constraints.

When a mismatch occurs between the objective of the test and the resources available, the test team needs to work with programme management to bring the objectives and the resources into alignment. If the programme is under-resourced and the risk of incurring Type I or Type II error is deemed to be too great, programme managers can either provide additional resources to bring the risk up to an acceptable level or they can modify the objectives. Conversely, if the risk analysis shows a low risk of incurring Type I or Type II errors, programme managers might choose to reallocate the resources to other higher risk programme elements.

### 1.8.3 Programme Tailoring, Phasing, and Regression Testing

The purpose of a DT&E test programme is to ensure that the SUT meets all of its critical specification and military utility requirements, and is ready to begin dedicated OT&E. The test team must construct a test

programme that tailors the test objectives to the most cost-effective resources for accomplishing them. For example, if a test objective can be satisfied using a laboratory facility this will almost always be timelier and less expensive than accomplishing it in-flight on an OAR.

Testers should be aware that testing described in previous sections does not usually occur in a linear fashion. Each programme has unique requirements and related test objectives that drive where, how much, and in what order testing will occur. For example, most programmes require multiple SIL entries to check out hardware, software, and mission data changes throughout the programme.

SUT maturity is a major driver in determining which resources are needed. A new acquisition programme will likely employ multiple iterations of all types of test resources. Alternatively, a mature system with developed hardware and software being installed on a new aircraft would employ resources focusing on airframe installation effects and avionics integration. Most major acquisition programmes employ block cycle upgrades or other scheduled incremental capability deliveries. When these new capabilities are delivered the test philosophy should address two aspects: evaluating the newly delivered capability and performing regression testing to ensure that existing capabilities have not been inadvertently degraded.

Sequential testing using lower cost resources to validate performance before progressing to more expensive and less available resources is good risk management practice. If deficiencies are identified in the course of using less expensive test resources, they can be resolved before moving on to higher-cost, higher-fidelity test resources. The test strategy should always aim to find problems as early as possible in the programme using the most cost-effective resources.

Regression testing is a critical risk-mitigation component of a well-designed test programme. Regression testing is performed to ensure that when a change is made to one part of the system other performance aspects of the system have not been unintentionally degraded. Since the incremental approach is a planned activity, regression testing should be built into the schedule. Failure to properly plan for and conduct regression testing can result in lengthy and costly changes late in the programme.

### **1.8.4 An Integrated Test Approach**

The system programme office has the overall responsibility for weapons system acquisition and ensuring that an integrated test programme occurs. There are two aspects to an integrated test approach. The first is organisational and deals with integrating the objectives of the stakeholding parties: the contractor, the government DT&E organisation, and the operational test agency. The second deals resource integration, i.e., ensuring that resources and facilities are employed in an efficient, cost-effective manner that avoids unnecessary duplication of effort. Figure 1-9 shows the resource categories and some examples of the types of activities that they support.



**1.8.5 Data Reduction and Analysis**

The test itself only provides data, observations, and information to be subsequently evaluated. The bridge between testing and evaluation is data reduction. Often, this step is thought to be a simple act of feeding data to the computers and waiting for the output to appear on the engineer’s desk. Experienced testers know differently; they are fully aware that factors such as selection of data, editing of outliers, and determination of statistical processes to be applied to the data can have a major effect on the outcome of the evaluation. A thorough understanding of experimental statistics is a prerequisite for the successful evaluation of any EW system.

**1.9 EW T&E RESOURCE UTILISATION**

**1.9.1 Relative Cost**

In general, the cost per test becomes higher as the testing moves to the right, as shown notionally in Figure 1-10. The use of models, simulations, and ground testing can reduce overall test costs since flight tests are the most costly.

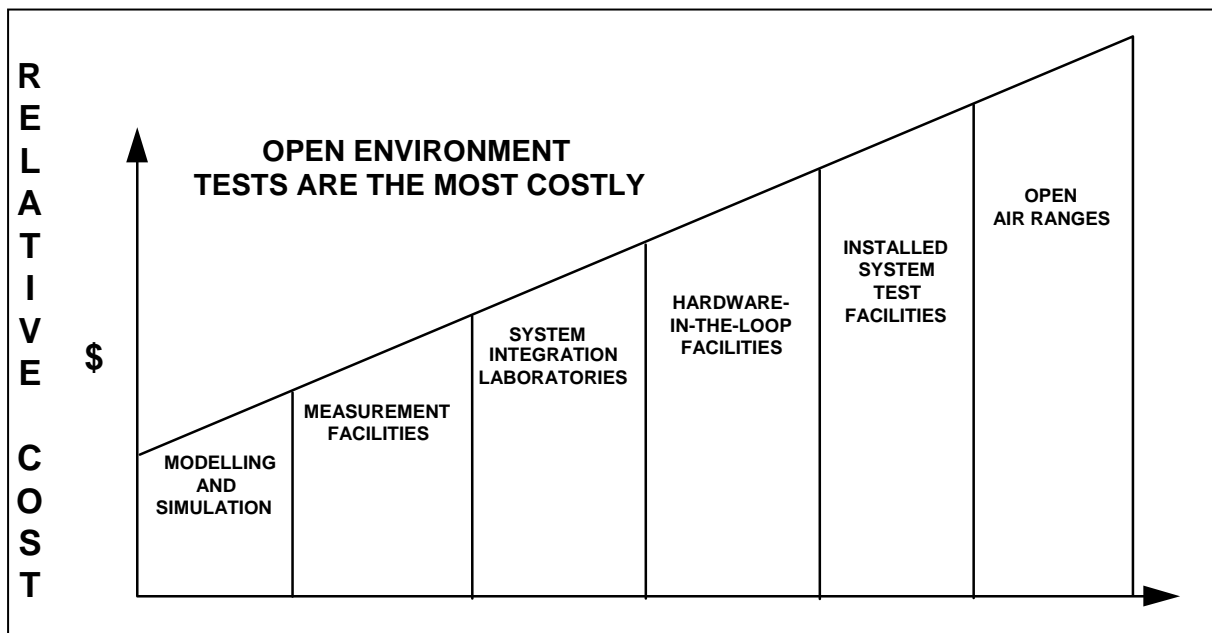

Figure 1-10: Relative Cost – T&E Resource Utilisation.

**1.9.2 Relative Use**

Due to the complexity of EW systems and threat interactions, modelling and simulation can be used in a wide range of progressively more rigorous ground and flight test activities. Figure 1-11, also notional, shows that M&S and MF are used throughout the test spectrum. It also shows how the number of trials/ tests should decrease as the testing proceeds through the categories.

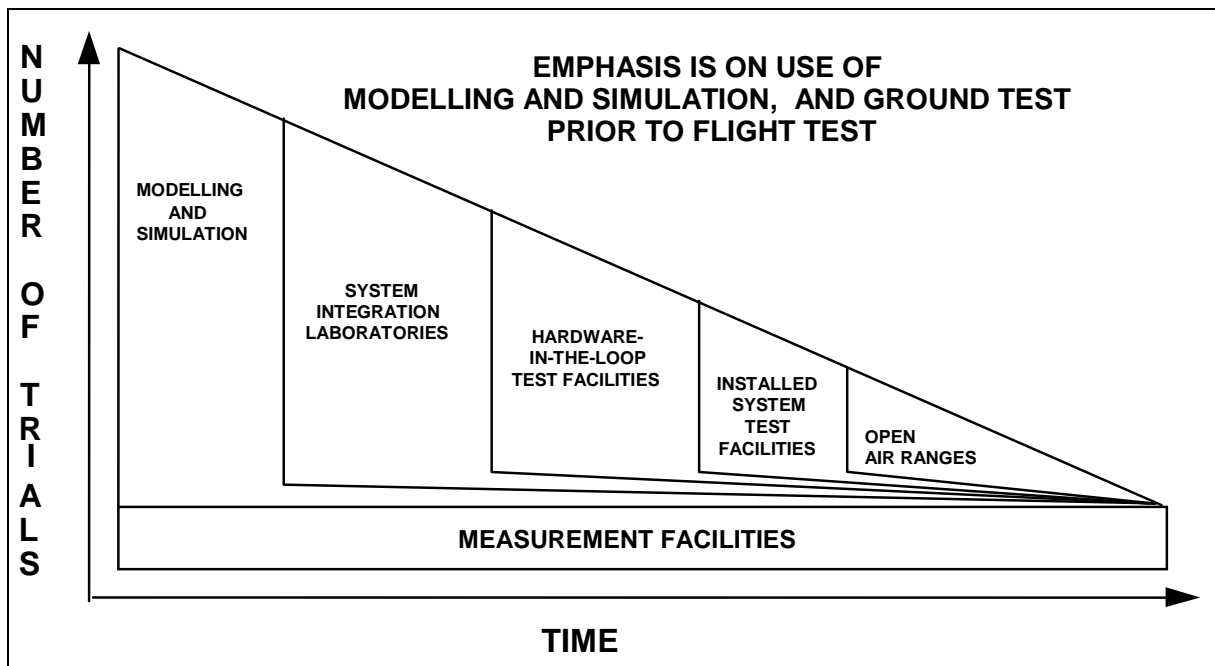

Figure 1-11: Relative Use – T&E Resource.

The key issue is to optimise cost, time, and risk of successfully gathering test evidence that allows SUT, system, and platform off contract and into operational use. To attain this two driving themes are:

- Move as much testing to the left of the development programme, i.e., from flight test to anechoic chamber ISTF and MF, and to M&S that has been subject to adequate Verification, Validation and Accreditation (VV&A).
- Only do in flight those tests that cannot be adequately achieved by ground test.

## 1.10 SAFETY CONSIDERATIONS

Specific safety procedures must be developed and observed for each type of test in each type of facility. The following hazards required particular attention when considering the T&E of EW systems.

### 1.10.1 Electrical Shock Hazards

Many EW systems utilise high-power transmitters requiring high-voltage excitation for the final output stages. In addition, nearly all EW systems make use of either 115 VAC or 28 VDC electrical power for operation. While these power sources are generally well protected when the system is installed in its operational configuration, they may be exposed and easily contacted during test activities. This is particularly true in the HITL and SIL environment.

### 1.10.2 Radiation Hazards

Effects of human exposure to high-intensity RF fields can vary from minor reddening of the skin to severe and permanent damage to internal organs. High power radiation can also cause equipment damage. The most common opportunity for such damage is in anechoic chambers. The Radar Absorbent Material (RAM) used in these chambers will absorb rather than reflect the RF energy from the systems in operation. The absorption of energy causes heating of the RAM. As a result, power levels must be carefully monitored



and constrained to levels below that at which the heating of the RAM will result in toxic smouldering or fire. Radiation hazards can exist in all test environments but are most frequently encountered in the ISTF and OAR testing phases.

### **1.10.3 Pyrotechnic Hazards**

EW expendables such as chaff and flares typically rely on pyrotechnic (explosive) devices for ejection. One can easily imagine the results of an inadvertent firing of these devices during ground maintenance or test operations. Also, EW pods carried on centreline or wing stations of aircraft are usually capable of being jettisoned. Unintended firing of the explosive charges that initiate the jettison sequence may result in both personnel injury and equipment damage. These pyrotechnic hazards are most likely to occur during ground test or preparation for flight test in the OAR testing phase.

## **1.11 THE TEST PLAN**

All test activities require careful planning to be successful. Test plans come in a multitude of forms and formats, each created to ensure a specific requirement or group of requirements are satisfied in the most complete and efficient manner possible.

### **1.11.1 Cost and Test Budget**

Adequate budgeting for each test event is critical. It is difficult to accurately predict the cost of an unplanned or poorly planned activity. Early in the programme when test events are not clearly specified, the budgeted cost for testing will likewise be only a rough estimate. The sooner more complete test planning is accomplished, the sooner the test budget can be accurately determined. Generally, as the programme progresses, the potential for acquiring additional funding is reduced. Poor budgeting at the beginning of the programme will nearly always result in cost overrun or severe constraints on test execution and failure of the test effort to deliver the required information.

### **1.11.2 Schedule**

As with the budget, the schedule for testing is affirmed through the development of detailed test plans. Test facilities that are needed to accomplish the desired testing may have full schedules. Access to the required facilities when needed is greatly increased if detailed test planning is accomplished early and this cannot be over-emphasised.

The schedule tends to be a major driver for the budget. Inaccurate schedule projections will generally lead to budget problems and, in the end, failure of the test programme to deliver the required information.

### **1.11.3 Test Efficiency**

Accomplishment of test events in the optimal sequence can substantially reduce the amount of retest or regression testing required. Test planning is the primary tool to understand and analyse the best sequence of events. It is also the process where experienced testers accomplish the trade studies to assess how programmatic risk will be affected by the elimination or insertion of test events.

### **1.11.4 The Bottom Line**

It is the test planning process that permits a logical sequence of test activities with reasonable expectations at each stage. Data reduction and analysis, safety, and certainly a meaningful evaluation are all virtually useless (and probably impossible to accomplish) without a carefully developed test plan.



## 1.12 TRAINING – A KEY TO SUCCESS

This Handbook primarily covers the EW T&E process and its underpinning facilities, tools and techniques. It must be recognised, however, that if the staff (engineers and other) involved in these areas do not have sufficient skill and experience, then the goal of programmes with minimum cost, duration and risk will be unattainable.

The EW T&E field is a complex one, requiring high levels of specialism and experience in a number of sub-disciplines *inter alia* microwave and optical engineering, mission systems engineering, platform design and development, electromagnetics, and rig and on-aircraft T&E.

EW and T&E training is therefore of great importance if the above goal is to be met. A number of Nations and agencies run EW and EW T&E courses that can satisfy this requirement. It has been shown that such training is a great experience accelerator for novices, allowing them to function at a much higher level than would otherwise be possible. This training can also enable experienced T&E engineers to solve difficult T&E problems and make contributions to their programmes by applying detailed technical knowledge obtained from the training. [23]

## 1.13 REFERENCES

- [1] Price, A., “The History of US Electronic Warfare, volume 1”, The Association of Old Crows, September 24, 1984, pp. 1-2.
- [2] Price, Vol. 1, pp. 12, 26.
- [3] Pheasant, V.A., “Window on Gomorrah”, J. Electronic Defense, Vol. 26, No. 7, July 2003, pp. 56-59.
- [4] Price, A., “The History of US Electronic Warfare, Volume II”, The Association of Old Crows, October 2, 1989, pp. 43-109.
- [5] United States Air Force Doctrine Center, Air Force Doctrine Document (AFDD) 2-5.1, “Electronic Warfare”, 5 November 2002, p. 14.
- [6] Rich, B. and Janos, L., “Skunk Works”, Boston, MA, Little, Brown and Company, 1994 (ISBN 0-316-74330-5), pp. 24, 85, 97-105.
- [7] AFDD 2-5.1, p. 26.
- [8] AAP-6 (2010): NATO Glossary of Terms and Definitions (English and French), 22 March 2010.
- [9] United States Chairman of the Joint Chiefs of Staff, Joint Publication (JP) 3-13.1, “Electronic Warfare”, 25 January 2007, p. V-3. [www.fas.org/irp/doddir/dod/jp3-13-1.pdf](http://www.fas.org/irp/doddir/dod/jp3-13-1.pdf) (Accessed 26 September 2011).
- [10] NATO Military Committee (MC), MC 64: NATO Electronic Warfare Policy.
- [11] NATO STANAG 6018: Allied Joint Electronic Warfare Doctrine – AJP 3.6(A). 5 February 2004.
- [12] JP 3-13.1, p. I-2.
- [13] JP 3-13.1, p. I-4.
- [14] JP 3-13.1, p. GL-8.

- [15] JP 3-13.1, p. GL-13.
- [16] JP 3-13.1, p. GL-5.
- [17] “Encyclopedia of Aerospace Engineering (2010)”, Edited by Richard Blockley and Wei Shyy. John Wiley & Sons, Ltd. (ISBN: 978-0-470-75440-5). Volume 7, Chapter 376 – Pywell, M. Electronic Warfare and Defensive Aids Systems Design and Development.
- [18] AFDD 2-5.1, p. 8.
- [19] JP 3-13.1, p. I-4.
- [20] Defense Acquisition University, “Glossary of Defense Acquisition Acronyms & Terms”, 12<sup>th</sup> Ed., Defense Acquisition University Press, Fort Belvoir, Virginia 22060-5565, July 2005, p. B-50.
- [21] “Glossary of Defense Acquisition Acronyms & Terms”, p. B-115.
- [22] Montgomery, D.C., “Design and Analysis of Experiments”, Hoboken, NJ, John Wiley & Sons, Inc., 2009 (ISBN 978-0-470-12866-4), p. 35.
- [23] Welch, M.J., The Electronic Warfare Test & Evaluation University. U.S. Air Force T&E Days, 5-7 February 2008, Los Angeles, California, AIAA 2008-1602.

### 1.14 FURTHER READING

NATO Terminology Management System and Database (NTMS and NTDB). <http://nsa.nato.int>.

Joint Doctrine Publication 0-01.1 United Kingdom Supplement to the NATO Terminology Database. 8<sup>th</sup> Edition, September 2011.

Price, A., “The History of US Electronic Warfare, Volume III”, The Association of Old Crows, September 2000 (ISBN 0-9703794-0-4).

“Jane’s Radar and Electronic Warfare Systems 2011 – 2012”. Jane’s Information Group. ISBN: 978-0-710-62967-8.

“Encyclopedia of Aerospace Engineering (2010)”, Edited by Richard Blockley and Wei Shyy. John Wiley & Sons, Ltd. ISBN: 978-0-470-75440-5. Volume 7, Chapter 376 – Pywell, M. Electronic Warfare and Defensive Aids Systems Design and Development.

## Chapter 2 – T&E OF ES SYSTEMS

### 2.1 INTRODUCTION

This chapter describes the basic operating principles of RF receivers, Missile Warning Systems (MWS) and Laser Warning Systems (LWS). The fundamental T&E methodologies for each type of system will be covered, beginning at the component level and progressing through fully installed system testing.

### 2.2 RF EW RECEIVERS

Nearly all modern RF EW systems employ some type of receiver system. Some receivers are designed for self-protection or real-time targeting; these receivers have stringent timeliness requirements and some degree of accuracy can be sacrificed to provide faster response times. Other types of receivers, such as those designed to support electronic reconnaissance and surveillance, have less stringent timeliness requirements but require greater accuracy to support their missions.

While different EW receivers serve a variety of functions, they share some common attributes. Figure 2-1 shows the basic functional architecture of most EW receiver systems:

- An aperture (usually a set of antennas to capture the RF signals of interest);
- A receiver to convert the RF signal to a video signal;
- A digitiser to convert the video signal to digital information; and
- A processor to perform the mission-specific tasks.

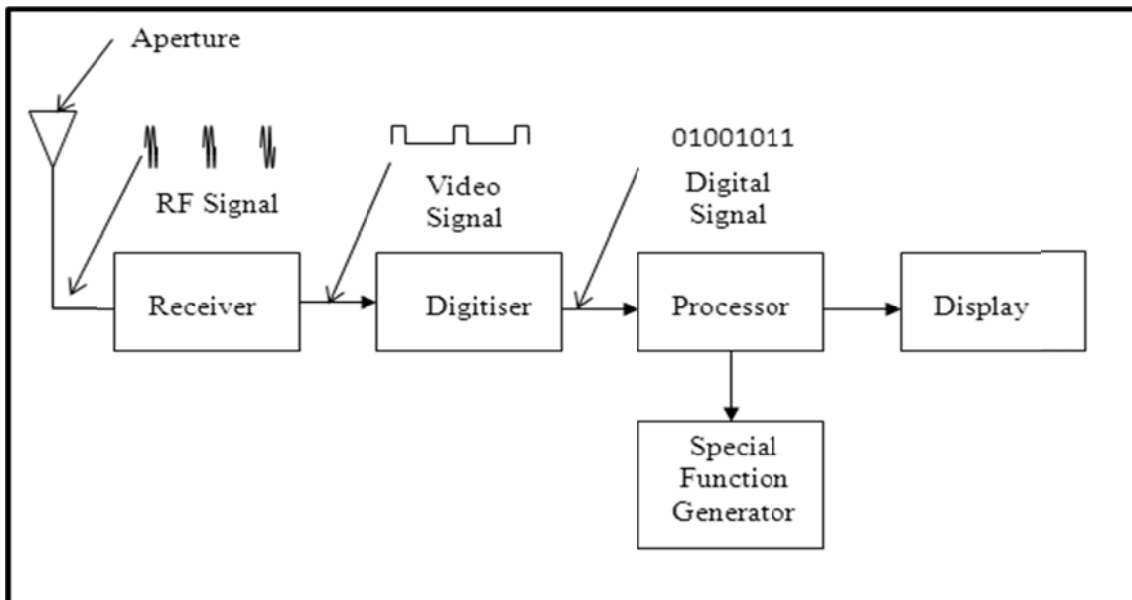

**Figure 2-1: Basic EW Receiver Block Diagram.**

The processor output drives aircrew interfaces such as displays and warning tones. The output is also provided to support special functions such as jammers, expendable countermeasures systems, etc. [1]

The Radar Warning Receiver (RWR) is the most widely deployed type of EW receiver system. An effective RWR performs two basic functions: to promptly warn the aircrew with sufficiently accurate information to

react to a threat engagement, and to provide threat radar parametric data to other countermeasures systems, such as chaff dispensers, to optimise their performance. It is of primary importance that an RWR provide prompt indication of threat activity to the aircrew.

An electronic reconnaissance and surveillance receiver differs from warning and targeting receivers in that its primary function is data collection in support of intelligence activities, with less emphasis on real-time applications. Electronic reconnaissance and surveillance receivers also usually make high-fidelity recordings of the intercepted signals for post-mission analysis. Since their primary application is intelligence related, they typically have more stringent requirements for accurate parametric measurements. Highly accurate Angle-Of-Arrival (AOA) information is needed in cases where emitter location is necessary.

Figure 2-2 shows the main types of EW receivers: RWR, Electronic Support Measures (ESM) and ELINT. It indicates their purpose and components, and the primary differences between them. In recent times, with the significant strides made in computing power and analogue-to-digital converters, the boundary between these three types has become increasingly blurred, especially so between RWR and ESM. For the remainder of this chapter, the term ‘RWR’ – from an EW T&E viewpoint – is thus considered to include ‘ESM’.

	<b>RWR*</b>	<b>ESM*</b>	<b>ELINT</b>
<b>PURPOSE</b>	<b>WARN AIRCREW OF RF-GUIDED THREATS &amp; CUE COUNTERMEASURES</b>	<b>DETECT/IDENTIFY &amp; PRECISELY LOCATE RF-GUIDED THREATS AT LONG RANGE. ECM CUEING.</b>	<b>INTERCEPTION &amp; ANALYSIS OF HOSTILE NON-COMMUNICATIONS EMITTERS. DETERMINE ENEMY EOB. NO ECM CUEING.</b>
<b>RECEIVER COMPONENT</b>			
<b>ANTENNAS (FREQUENCY SUB-BANDED)</b>	4 SPIRALS/FREQUENCY BAND FOR AZIMUTH. 4 MORE FOR ELEVATION	INCREASED No./TYPES OF ANTENNAS, INCLUDING PHASED ARRAYS, SPINNERS	USUALLY MULTIPLE, FREQUENCY-BANDED OMNI AND DF ANTENNAS
<b>RECEIVERS, ANALYSIS &amp; PROCESSING</b>	WIDEBAND & SUB-BANDED, CHANNELISED RECEIVERS. ANALYSIS SHARED WITH STAND-ALONE PROCESSOR	AS RWR + OTHER TYPES, e.g. IFM. BETTER DF TECHNIQUES. INTEGRATED PROCESSING	MULTIPLE FREQUENCY SUB-BANDED SEARCH/ACQUISITION & SET-ON/ANALYSIS RECEIVERS. INTEGRATED PROCESSING NOW COMMON
<b>RECORDING</b>	RARE	BECOMING COMMON	DATA ALWAYS RECORDED
<b>DISPLAYS &amp; CONTROLS</b>	OFTEN STAND-ALONE	OFTEN PART OF INTEGRATED AIRCRAFT D&C	PER-RECEIVER D&C COMMON. LATEST HAVE INTEGRATED D&C

\*ECM RECEIVERS HAVE RWR/ESM CAPABILITY

**Figure 2-2: EW Receiver System Types.**

Two other important elements of EW receiver systems are the operational flight programme (OFP) and the Mission Data Files (MDFs). The OFP is software and it functions like a computer’s operating system, controlling the executive functions of the system. The MDF is analogous to a computer application; it defines how the receiver searches for and acquires signals. The MDF also contains the parametric threat definitions derived from intelligence sources, e.g., a given threat’s target-tracking (TT) radar operates in a given frequency range, on a series of potential pulse repetition intervals (PRI) (or determines whether it is a Continuous Wave [CW] signal), and a scan type and/or rate (for scanning radars).

The importance of mission data in modern receiver systems cannot be overstated. In scanning receivers, such as superheterodynes, the receiver will only survey the RF environment in the manner that it is programmed. Mission data changes can fundamentally change the way that the system operates. To the tester this means that each MDF can exhibit significantly different performance and be considered as a new test item.

The management of hardware, software, and mission data also has organisational implications, see Figure 2-3. The developing and sustaining organisations are responsible for the hardware and software. The mission data

is the responsibility of the military end user. In the case of a common RWR employed on both a fighter and a transport aircraft, for example, the hardware and software will be nearly identical and commonly managed, but the aircrafts' different missions will require the military end users to tailor the mission data to suit their individual requirements.

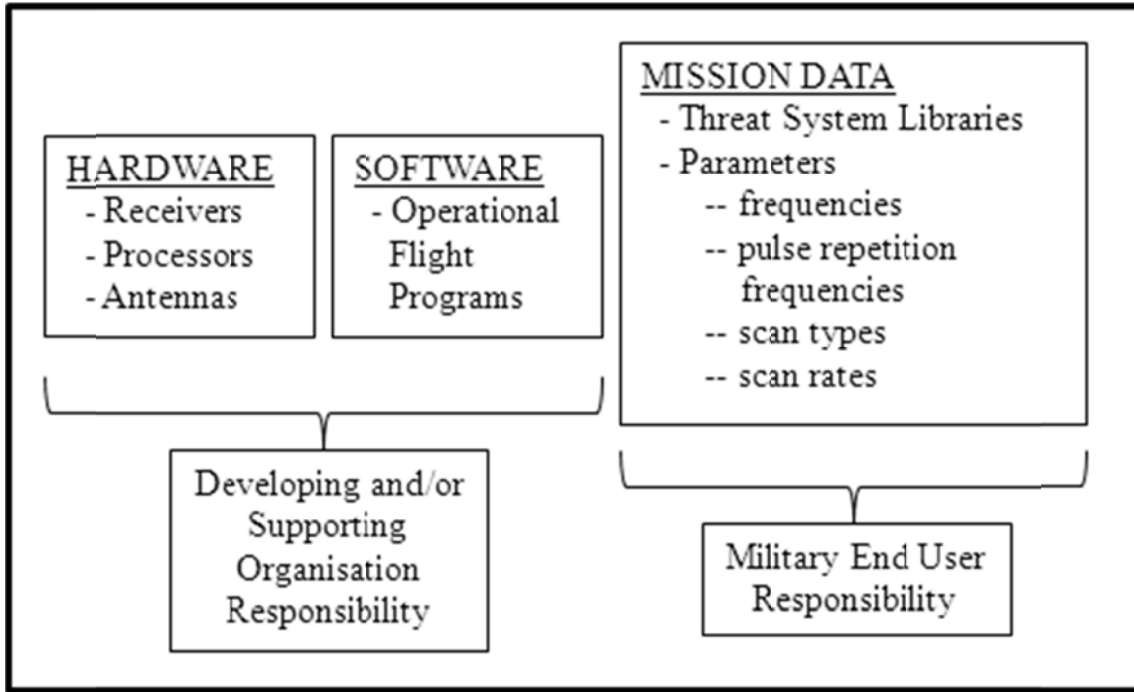

Figure 2-3: EW Receiver Elements and Organisational Responsibilities.

### 2.2.1 RWR System Components and Operation

The following section describes the typical components and operation of an RWR. Other EW receiver systems have similar types of components and operate in a similar manner. Figure 2-4 shows the basic layout of an integrated RWR, i.e., one that interfaces with other aircraft systems.

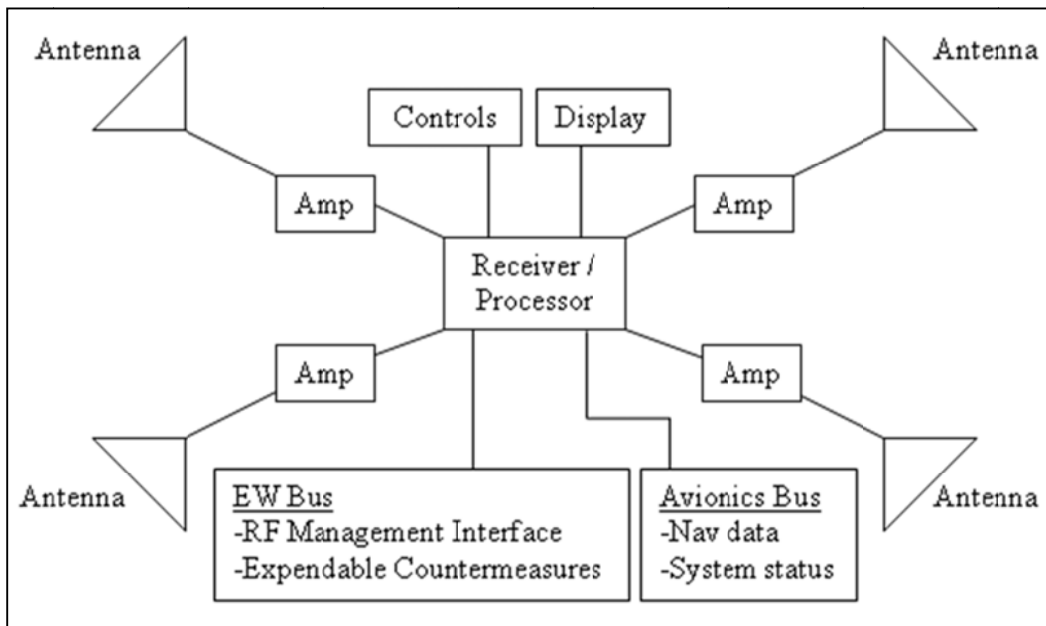

Figure 2-4: Typical Radar Warning Receiver Components.

**2.2.1.1 Antennas and Transmission Lines**

RWRs usually employ an array of antennas. These antennas are electromagnetic apertures tuned to the portion of the RF spectrum of interest. RWR antennas are broadband and typically cover the 2.0 – 18.0 GHz frequency range. Four orthogonally mounted antennas, each with an azimuth beam-width of approximately 90 degrees, are commonly used to cover 360 degrees in azimuth. On tactical aircraft the locations are usually at 45, 135, 225, and 315 degrees with respect to the nose of the aircraft. Elevation coverage varies, in some cases up to 360 degrees, but is typically around 30 degrees. Figure 2-5 shows a typical RWR/ESM antenna.



Figure 2-5: Typical RWR/ESM Antenna – (With permission, TECOM Industries Inc.).

The antennas generally connect to the receiver/processor in one of two ways:

- Via coaxial cable, often with an amplifier in the line to boost the analogue signal strength supplied to the receiver; and
- By employing a digital receiver located close to the antenna, which converts the analogue signal to a digital format and transmits it to the processor, thereby minimising signal power loss.

### 2.2.1.2 Receiver

Receivers are designed to detect specific radar signals at specified ranges and the installed receiver must have sufficient sensitivity to accomplish this task. The required sensitivity is calculated using the one-way radar range equation to determine the power density at the specified range. The installed receiver must be able to detect the signal at the calculated power density. Figure 2-6 shows a typical RF receiver transmission line and the installed sensitivity calculation.

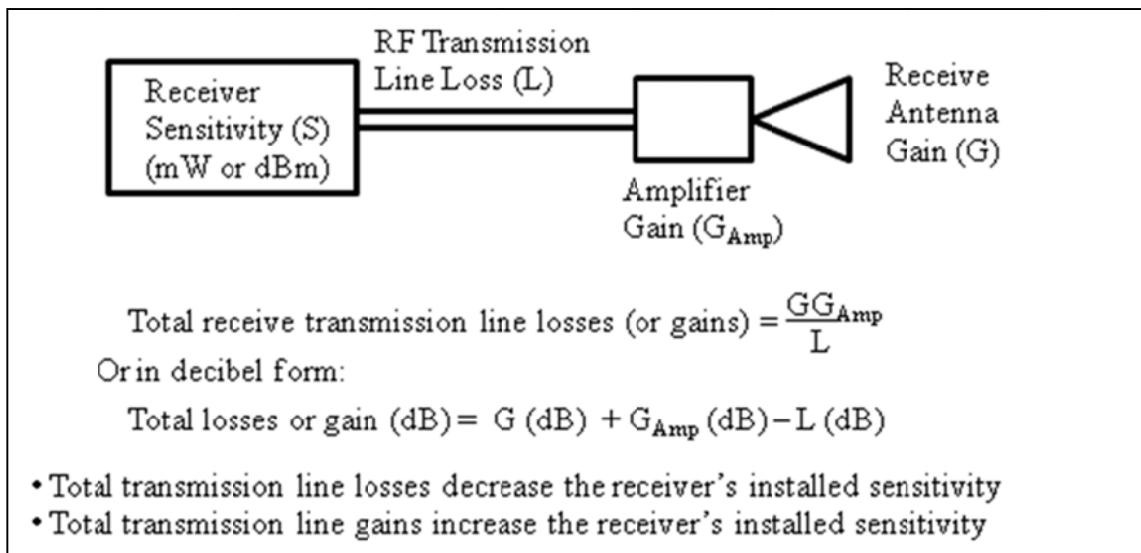

Figure 2-6: Receiver Transmission Line Components and Installed Sensitivity.

The receiver performs several functions related to signal parameter determination. The receiver creates a Pulse Descriptor Word (PDW) for each incoming pulse based on its measurements. A typical PDW is composed of information about the pulse: time of arrival based on an internal clock, AOA, signal amplitude, pulse width (or a determination that the signal is CW), and frequency.

### 2.2.1.3 Data Processor

The data processor takes the incoming PDWs and attempts to aggregate them into discrete pulse trains using discriminators such as AOA and frequency. Once a pulse train has been identified, additional parameters such as the PRI and radar scan type and/or rate can be measured. The PRI is merely the time between successive pulses, while the scan rate and type can be determined by analysing the time variation of pulse amplitudes. Scan rate and type information can be strong indicators of the lethality posed by the threat system.

When the individual pulse trains have been deinterleaved, they are compared to the parametric data contained in the MDF. If they match the MDF definitions, the threat beams and modes can be determined.



Further, if a threat radar system employs more than one beam, such as an acquisition radar and a TT radar, these component beams can be correlated.

Determining the AOA of a threat radar signal is an important RWR task. Amplitude comparison is a technique commonly used by RWRs to determine the AOA. The RWR typically employs four orthogonally mounted antennas arrayed azimuthally around the aircraft. The RWR samples the amplitude of an incoming signal through each antenna and can estimate the direction of the incoming signal by comparing the relative amplitudes of the four received signals.

**2.2.1.4 Installation and Integration**

Modern RWRs rarely operate in a standalone fashion. They commonly provide threat specific information via a data bus to other countermeasures systems such as chaff dispensers, jammers, and towed decoy systems allowing them to optimise their performance. Additionally, some functions such as emitter geolocation require the RWR to receive navigation and other information via data busses.

The information provided to the pilot indicates the type of radar that is directing energy toward the aircraft and possibly its mode of operation, its relative bearing, and an estimate of its range, together indicating its potential lethality. Many systems utilise a 3” (7.5 cm) diameter Cathode Ray Tube (CRT) to present this information to the aircrew. In newer systems the information may be presented on a page of a Multi-Function Display (MFD). The displays are oriented such that the top of the display represents the nose of the aircraft and the bottom of the display the aft of the aircraft. There may be several concentric rings on the display that are used to separate multiple threats by lethality. Many newer integrated systems display the RWR threat indications on MFDs.

The AN/ALR-56M is a widely deployed RWR. Figure 2-7 shows the system components and lists their functions. Figure 2-8 illustrates the case where a single RWR system type can be employed by more than one aircraft; in this case the F-16 and the C-130J.

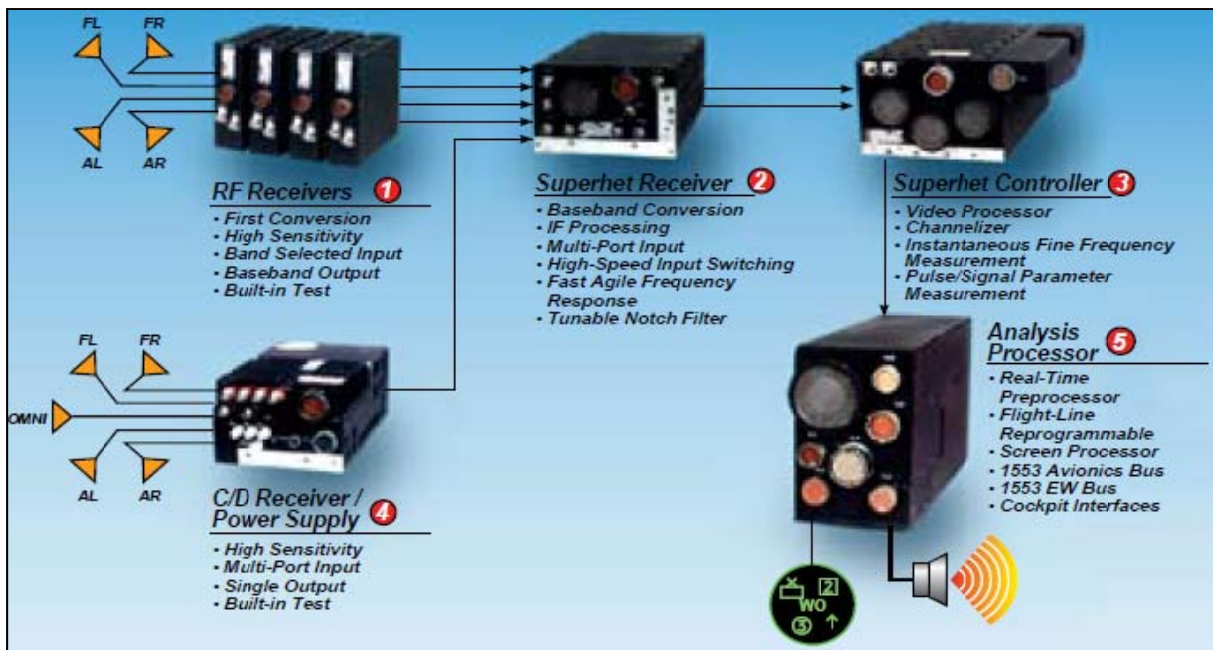

Figure 2-7: RWR Components and Functions – (Courtesy of BAE Systems).



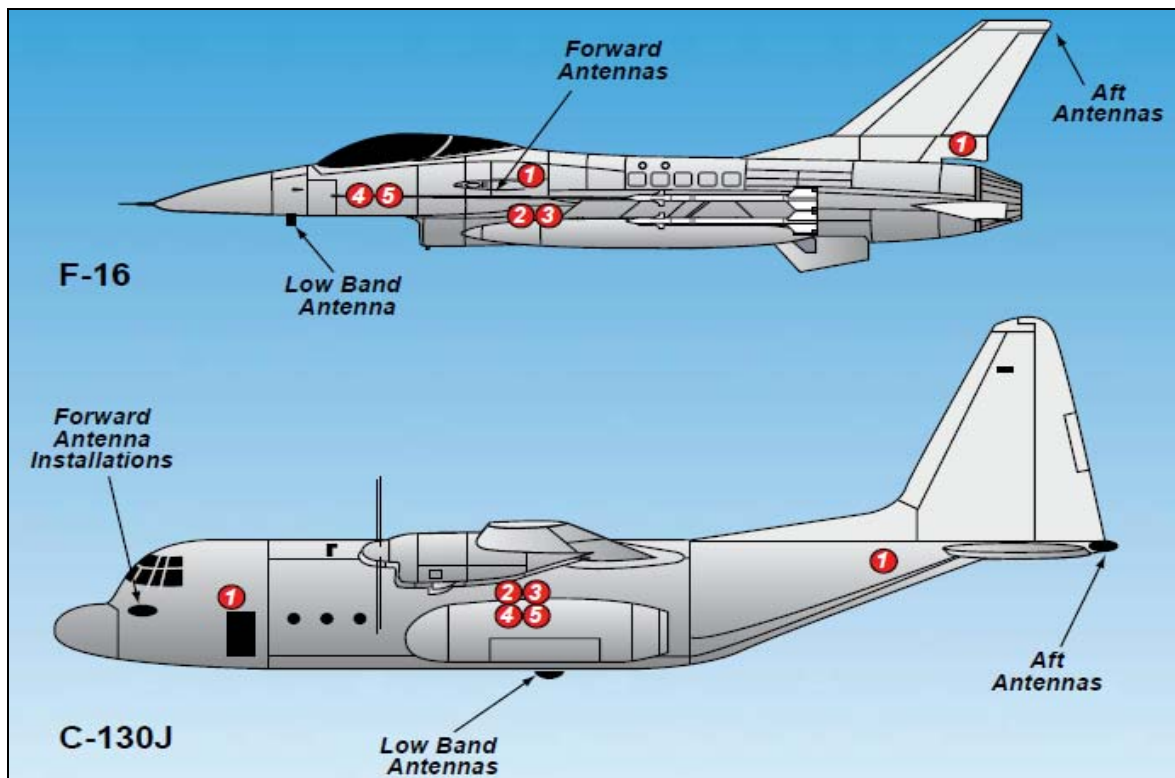

Figure 2-8: RWR Component Locations – (Courtesy of BAE Systems).

### 2.2.2 EW Receiver Testing (RWR Focus)

This section addresses the T&E of EW receiver systems. The following discussion focuses on RWRs but applies to other types of EW receivers.

There are many factors to consider when testing an RWR. The high-level requirements are easy to define. The system must be able to detect and identify specific radar beams, associate them with threat systems, and provide data to other countermeasures systems and the aircrew in an operationally representative environment within a specified amount of time period. These requirements are provided to the system manufacturer in a specification document.

RWR specifications and testing can be broken down into three main categories:

- DT&E of the uninstalled RWR and its constituent components;
- DT&E of the RWR as installed on the host aircraft; and
- OT&E to determine if the overall system is effective and suitable to perform its intended mission.

Each of these categories will be treated as discrete elements of testing in the following discussion. However, overlap does occur and can be very helpful in reducing programme risk. Shared participation by the following agencies' test teams allows decision makers to have access to comprehensive information throughout the programme:

- SUT manufacturer/supplier test team.
- Developmental test team, whether PSI, military or defence research agency.
- Operational (military) test team.

**2.2.2.1 Uninstalled RWR Component and System-Level Testing**

The RWR performance requirements can be functionally separated into testable requirements for each component. Some examples include receiver sensitivity, dynamic range, frequency selectivity, RF transmission line losses, pulse handling capacity for a receiver, and antenna gain over a field of view for a given frequency range and polarisation. These tests are normally performed by the RWR manufacturer using their laboratory test resources augmented by antenna pattern data generated from M&S sources or produced using measurement facilities. The results of these tests can also be extrapolated to estimate overall system performance.

The RWR component testing addresses design, development, and system performance. Design and development aspects are beyond the scope of this document. Individual component performance verification is important because if the individual components do not perform to their specified requirements, the overall system is unlikely to perform to its specified requirements. It is difficult to speak generically about receivers because almost every receiver is tailored to meet the specific needs of the system for which it was designed. There are, however, a few common measurements that are helpful to understand and these are described in the following sub-sections.

*2.2.2.1.1 RWR Component Testing*

Although comprehensive details of component-level testing are beyond the scope of this Handbook, it is helpful to be familiar with some of the measurements that characterise components. For additional information the interested reader is referred to [4]. Table 2-1 lists some commonly used receiver measurements, their definitions and their relevance to overall system performance. Other definitions are used and it is important to understand the specific meaning being used, particularly as applied to specification requirements.

**Table 2-1: Common Laboratory Measurements on Receivers.**

<b>Measure</b>	<b>Definition</b>	<b>Relevance to System Performance</b>
Minimum Discernable Signal (MDS)	The lowest power signal that can be discerned from the noise, i.e., the point where the signal power is equal to the noise power in the receiver. [2]	Receiver sensitivity directly relates to the maximum range at which a receiver system will be able to detect an emitter.
Frequency Selectivity	The ability to distinguish between signals closely separated in frequency.	The ability to process information from two emitters operating in close frequency proximity.
Dynamic Range	The input signal amplitude range that the receiver can process properly. The lower limit is the receiver sensitivity (MDS is commonly used). There is no universally accepted definition for the lower or the upper limit of the input signal level. [3]	The ability of a receiver to detect and process two simultaneous signals of different amplitudes and frequencies.
Signal Density Handling	The specified environment within which the receiver must be able to meet its other requirements for detecting and processing emitters. The number of pulses per second along with the number of CW signals is specified as well as the number and types of radars and their location (frequently specified by quadrant).	Relates to the ability of the receiver to operate in its intended environment without being unacceptably degraded.

2.2.2.1.2 *Antenna Measurements*

Antenna performance is a major contributor to overall receiver system performance and it is specified in two ways. The first is relative to the uninstalled configuration, which normally identifies the performance requirements for the antenna manufacturer. The second is relative to the configuration as installed on the aircraft. Generally the installed antenna pattern will be significantly different than the uninstalled pattern due to the electrical effects of the airframe. Installed antenna patterns have a significant effect on the overall system sensitivity and the AOA measurement accuracy.

Antennas are differentiated by physical size and electrical performance, in terms of gain versus frequency and gain versus AOA of the signal. Ideally, RWR antennas would be small in physical size, and have a positive constant gain over all frequencies and angles. It is possible for RWRs to cover the 2-to-18 GHz band with 3 dB (half-power) beam widths of approximately 90 degrees.

Antenna location on the aircraft can greatly influence the operation of the entire RWR. Computer modelling is used to design antennas and optimise antenna placement. Figure 2-9 shows several uninstalled RWR antennas and the left-forward quadrant antenna installed on an F-16 aircraft.

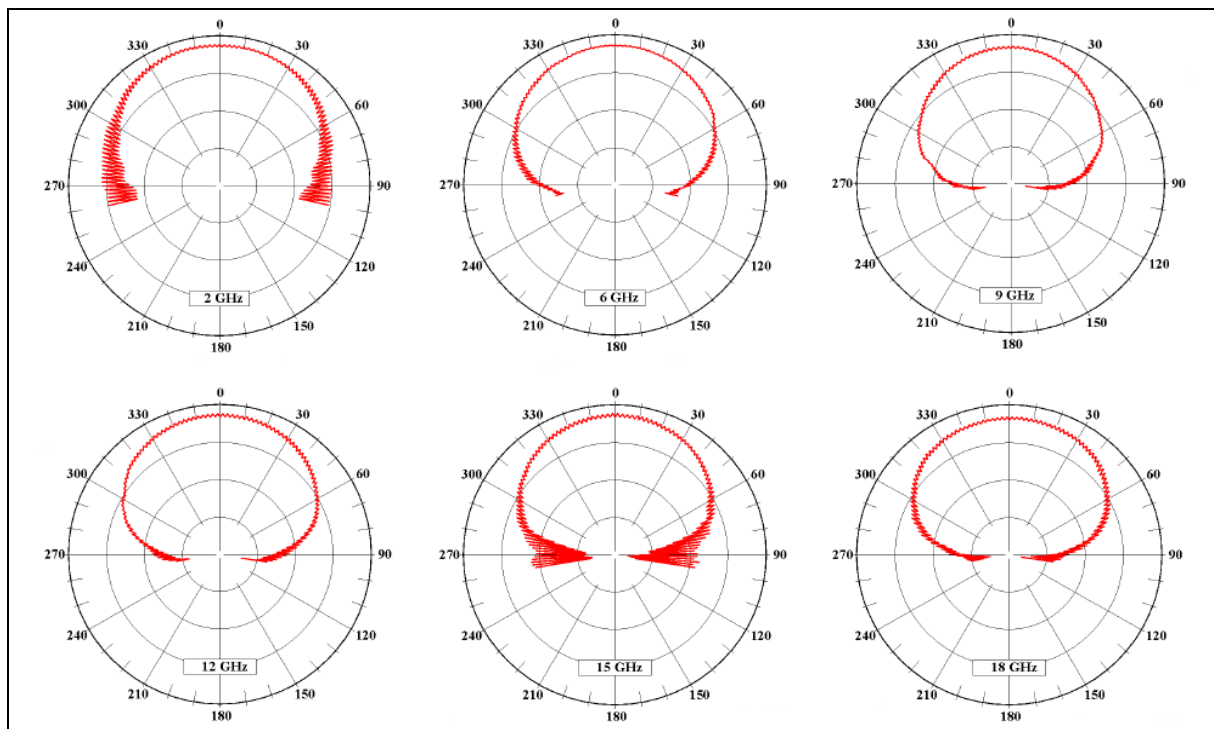

**Figure 2-9: a) Uninstalled RWR Antennas – (Courtesy L3 – Randtron Antenna Systems);  
b) Installed F-16 RWR Antenna – (U.S. DoD Photo).**

Aircraft stores, such as missiles, bombs, and fuel tanks can significantly affect the RWR antenna patterns – an effect known as obscuration. Obscuration limits the useful locations of EW antennas and is the reason why on some aircraft the RWR/ESM antennas are mounted in wing tip pods, e.g., Eurofighter Typhoon. Computing modelling of obscuration and other installed performance effects early in the design phase usually leads to optimum placement of antennas and minimum cross-coupling between antennas and their attached receivers. Such computational EM can likewise be of assistance during the T&E phase to isolate, investigate and aid resolution of any installed EW system performance issues that may arise.

LO aircraft pose a special problem for receiver and system designers. The installed antennas must have sufficient gain over the system field of view to accomplish the mission while not compromising the aircraft signature.

Due to their small size and the frequency ranges of interest, uninstalled antenna pattern measurements can usually be made in a small anechoic chamber. Figure 2-10 shows representative uninstalled azimuth antenna patterns and their variation over the 2 – 18 GHz frequency range. Installed antenna pattern measurements are commonly performed using outdoor far-field measurement facilities. Measurements are typically performed on full-scale mock-ups of either full or partial sections of the aircraft.



**Figure 2-10: Representative Azimuth Uninstalled Antenna Gain Pattern Measurements – (Courtesy L3 – Randtron Antenna Systems).**

Up front investments in antenna pattern measurements can provide significant risk mitigation. Redesigning antenna installations after unacceptable deficiencies have been identified in flight test can have serious cost and schedule consequences for acquisition programmes.

#### 2.2.2.1.3 RWR System Level Testing

The primary purpose of RWR system-level testing is to support the manufacturer's system development and evaluation of system performance before progressing to installed system testing. System-level testing can be conducted at either the manufacturer's SIL, the PSI's Sub-System Laboratory, or at dedicated government SILs. The level of threat simulation fidelity and scenario complexity at manufacturer's laboratory facilities vary widely, from relatively low-fidelity signals and static scenarios to high-fidelity signals and dynamic scenarios.

Figure 2-11 shows a typical RWR system-level SIL configuration. At the heart of the test are the complete RWR hardware, software, and mission data. Normally, the input signals are directly injected into the receiver system and the antennas are not part of the test configuration. Additionally, most modern RWRs function as part of an integrated system on the host aircraft and interface via data buses with the other EW, avionics, and RF management systems. The RWR manufacturer typically does not have the full-up hardware and software for these systems and the data bus communications are simulated using computer-based emulators.

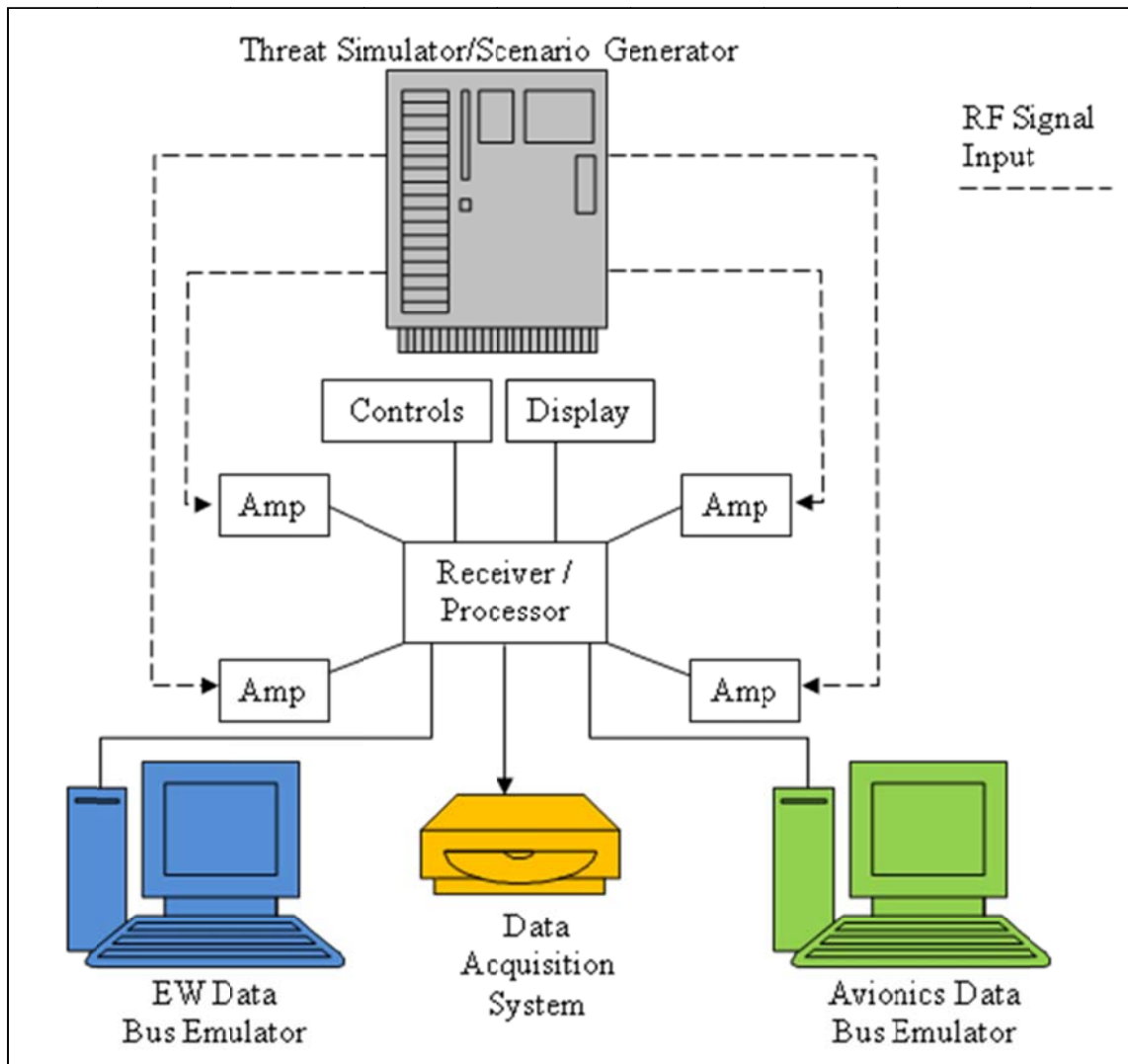

**Figure 2-11: Typical RWR Manufacturer's SIL Configuration.**

Complex dynamic scenarios are possible, but the RF threat simulator and scenario generator must vary the input signal amplitudes to simulate the changing threat-to-target range while accounting for the antenna effects. Antenna effects can be simulated using either modelled or measured antenna gain patterns.

System integration laboratories can be used to achieve two main objectives:

- Evaluate the performance of the uninstalled RWR system and its components; and
- Evaluate the communication between the RWR and other simulated onboard systems.

The SIL testing can evaluate the system performance against a variety of simulated threat radar systems. The specific threat systems are normally defined in the system specification and document the specific characteristics of each radar component of the threat system including: frequency ranges, PRI ranges, signal polarisation, scan types, scan rates, pulse widths, etc.

Important performance characteristics of the system can be evaluated during SIL testing allowing designers to optimise software and MDF performance. Identifying and correcting deficiencies during SIL testing allows changes to be incorporated relatively quickly, since flight certification isn't generally required.

Nearly all radars have more than one beam or mode that the RWR must detect and identify. Additionally, the RWR must perform these functions within a tactically meaningful time span. The MDF specifies the signal characteristics associated with each radar beam and mode. Initial system level testing should focus on the ability of the RWR to correctly identify each required beam and mode and the associated response times.

After the system performance has been optimised for each beam or mode and a baseline established, testing can progress to more representative scenarios. The simulated engagement scenarios model the behaviour of real individual radar directed weapons systems, e.g., a typical radar system will progress from an acquisition mode to a target tracking mode to a missile launch mode. The system should properly handle concurrent beams and mode transitions. The following paragraphs describe a typical radar directed threat engagement and the desired RWR behaviour.

A typical threat system employs a two-beam scanning acquisition radar operating on two discrete frequencies, a TT radar, and a Missile Guidance (MG) radar. Depending on how the threat is operating, one to four distinct beams may be illuminating the target aircraft. In a nominal engagement, the acquisition radar will be active and searching for targets. Once a target has been identified, the TT radar will begin transmitting and track the target. Finally, when a good track has been established the MG radar will activate to guide the missile. The MDF defines how these beams should be displayed.

The desired RWR response to this engagement is:

- The RWR should recognise that the two beams of the acquisition radar are part of the same system and should continue internally tracking both beams while correlating them and only display a single symbol representing the acquisition radar.
- When the TT radar becomes active, the RWR should internally correlate all three beams to the same system and promote the acquisition symbol to indicate that the threat status has escalated.
- Finally, when the MG beam activates the RWR should again internally track and correlate all four beams while promoting the symbol from a track indication to a missile launch indication. There should never be more than one symbol present at any time for a given threat system and it should always reflect the status of the most lethal condition associated with the identified radar beams.

The main limitations of system level SIL testing relate to the simulated antenna effects and the external data bus emulation. Most tactical RWRs determine the range to the threat radar by measuring the received power and calculating the range based on that power measurement. The installed antenna gain patterns significantly affect this measurement and even the best simulations only provide an estimate of the actual installed system ranging performance. Similarly, most tactical RWRs use a technique called amplitude comparison to determine the relative bearing to threat. The system compares the signal amplitude received by each antenna (typically by quadrant) and using this information can determine the signal's AOA. The SIL testing is very useful for developing ranging and AOA techniques, but the resulting data should be used with caution.

Since most EW T&E facilities employ direct injection of RF signals into the SUT, the antenna effects must be modelled based on the antenna-pattern data available. The injected RF energy needs to be amplitude modulated to account for antenna-gain variations over the pattern. The quality of the performance estimate is directly related to the quality of the available antenna-pattern data. Antenna data sources include: assumed-perfect patterns (smooth over the regions of interest), software-modelled patterns, or data from far-field



antenna ranges. There are other AOA measurement techniques, such as phase interferometry and they present more complicated challenges to a laboratory environment. Analysts should be familiar with the limitations of AOA performance predictions based on laboratory and ground test results and use them with care.

System level integration testing is generally limited to computer-based data bus emulators which can be used to ensure that the system complies with the input and output message protocols specified in the Interface Control Documents (ICD). This level of testing rarely involves actual hardware for the data buses and other systems.

These facilities also provide an opportunity to stress the receiver system with dense signal environments to determine if the RWR can still meet its required performance specifications when the receiver and processor are heavily loaded. This test environment also allows testers to evaluate RWR performance where threat simulators or actual radar systems are not available on an OAR.

Ground testing using OAR assets can also be used to reduce risk. A receiver system can be rack-mounted and taken to an OAR where the system can get exposed to high fidelity simulators and actual radar systems. Actual radar systems have a number of peculiarities that are not necessarily captured in laboratory representations of the signals. [5] For example, a system that is considered to operate on fixed discrete frequencies may have a significant frequency shift that occurs on power up. If the RWR MDF doesn't account for this, the system might interpret the behaviour as multiple instances of the same threat system and generate multiple symbols on the display. This type of testing is a very cost-effective way to optimise the mission data prior to flight test.

#### **2.2.2.2 Installed RWR Testing**

Installed systems testing takes place with the RWR system integrated with other platform systems. There are three levels of installed system testing: the first occurs in a laboratory environment where the RWR is integrated with actual aircraft systems (this is not strictly speaking an installed system test since the SUT hardware and software are not installed on the host platform. However, it is a critical developmental activity); the second takes place during ground testing on an aircraft; and finally, flight testing is conducted using an OAR.

##### *2.2.2.2.1 Integration Laboratory Testing*

The first time an RWR sub-system will be integrated with actual aircraft hardware is normally in the aircraft contractor's or PSI's SIL facilities, also called Defensive Aids Sub-System (DASS) and Avionics Integration (AI) laboratories. These facilities, as illustrated in Figure 2-12, commonly employ mock-ups of the airframe including the cockpit and using actual hardware, cabling, and software wherever possible. In many cases, sub-systems such as the FCR are fully operational. Since previous RWR testing has been conducted with computer emulated data buses the increased level of fidelity provided by generating actual data bus traffic provides a good measure of risk reduction prior to actual on-aircraft test activity.

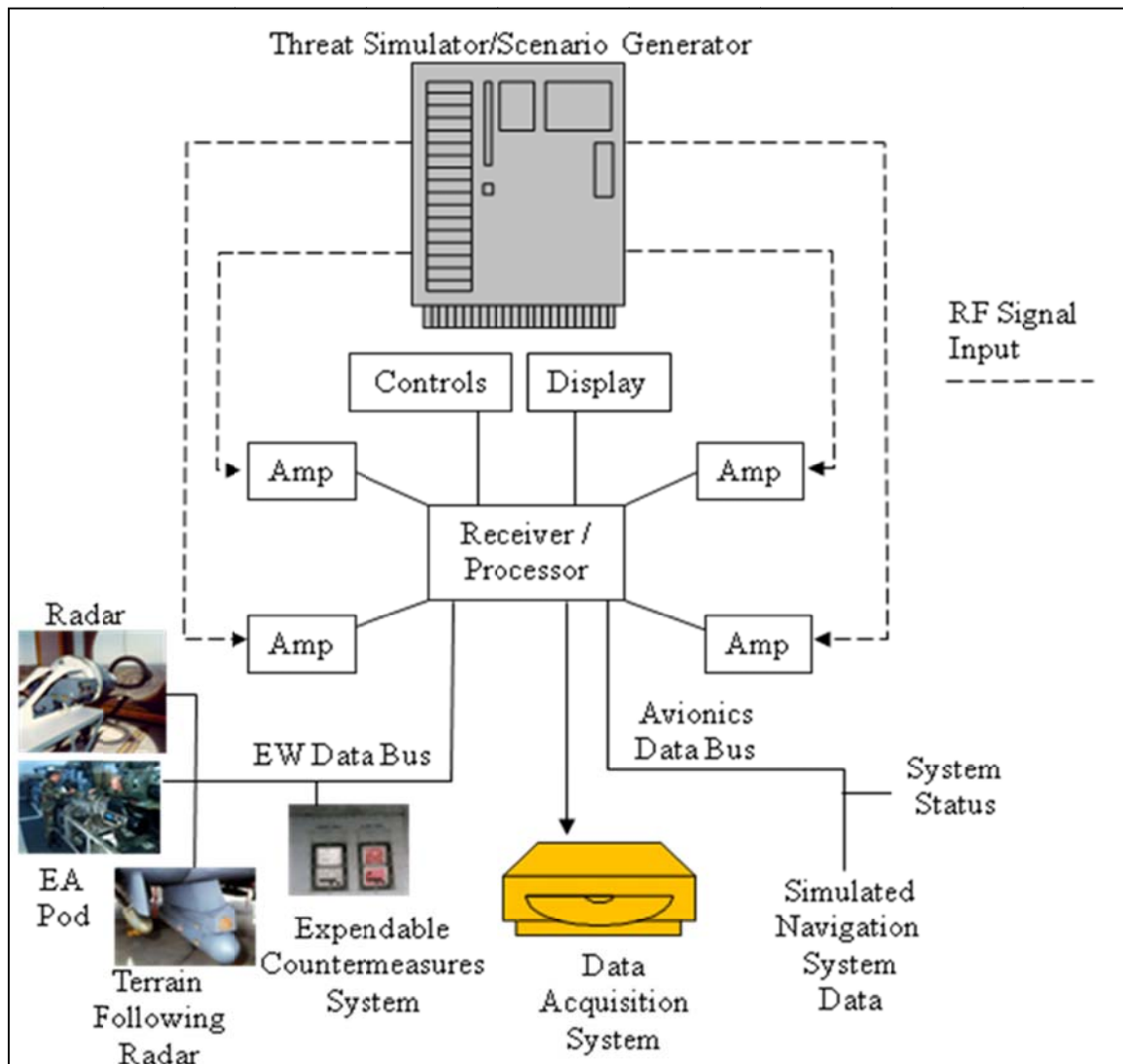

Figure 2-12: Typical Airframe Manufacturer's SIL Configuration.

The simulated RF threat signals are typically directly injected into the receiver, a technique known as 'post-antenna injection' or 'direct injection'. Testing in SIL and AI laboratories generally involves low-to-medium threat scenario densities since the emphasis is on system integration, although this can vary considerably by airframe contractor and PSI. DASS laboratory testing generally uses higher densities. Threat scenario densities used on high fidelity threat simulation equipment in these facilities can differ across Nations.

#### 2.2.2.2.2 Installed System Ground Testing

Installed system ground testing can occur either in a specialised ISTF or at a convenient location on the flight line. The location of the testing is driven by the test requirements. On-aircraft ground testing allows testers the first opportunity to evaluate RWR system integration and performance on a fully equipped test article. Ideally, the test aircraft will have an RWR system installed in a production representative configuration along with all the RF transmitting systems and RF management equipment. The RF management system



coordinates activity among the onboard transmitters and receivers, e.g., the fire-control radar provides information about its RF transmission to the RWR so that the RWR won't process and track it as a threat.

EMC testing is conducted to determine if the onboard RF transmitters cause EMI with the operation of onboard receivers, such as RWRs and other EW receivers, or other onboard equipment. Testing is conducted by analysing characteristics of the aircraft systems and generating a 'source – victim matrix'. This matrix identifies RF transmitters and the modes of operation most likely to interfere with the receiver systems and their operating conditions. This is typically a large matrix and a time-consuming test. Each transmitter is operated under each specified condition while the victim systems are monitored for interference. Interference can manifest itself by generating false RWR threat file tracks and/or erroneous symbols on the RWR display.

EMC testing is best conducted using an ISTF, i.e., an anechoic chamber, although if one is not available the testing can be done on the flight line. The advantage of using an anechoic chamber is the high degree of isolation from extraneous ambient RF signals. Outdoor testing in a high-ambient RF noise environment has several potential pitfalls. One is that the ambient noise will desensitise onboard receivers; another is that RF reflections from stationary objects can cause interference (such as a FCR transmission reflecting off of a hangar and causing the RWR to display a symbol) that would not occur in an anechoic chamber or in flight. Figure 2-13 shows a CV-22 aircraft undergoing testing in an anechoic chamber.

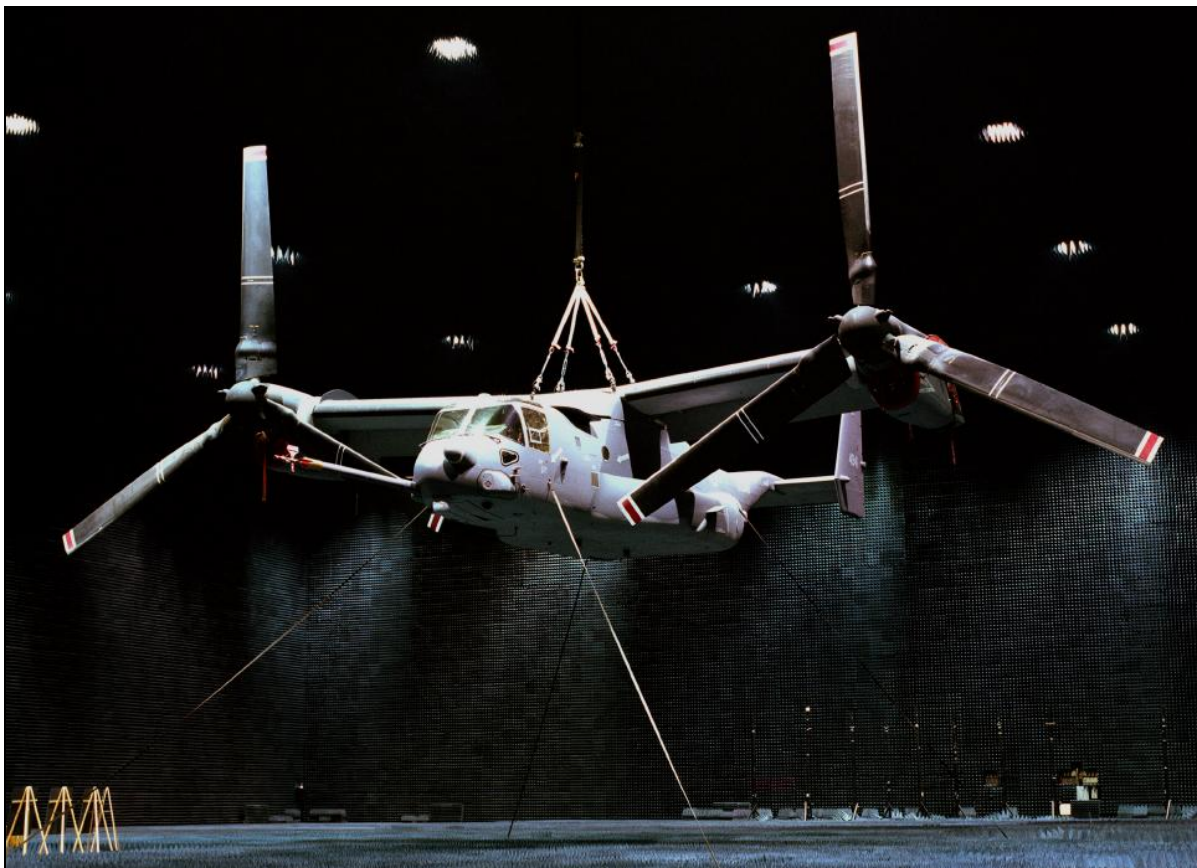

**Figure 2-13: CV-22 in the Benefield Anechoic Facility, Edwards Air Force Base, California, United States – (USAF Photograph).**

EMC ground testing is an excellent screening tool to reduce the number of conditions that need to be examined in flight. In most cases there will be a small number of conditions where interference is noted.

Unless there are safety of flight concerns these conditions should be repeated in flight to verify that the condition actually exists and not an artefact of the ground test configuration.

In addition to EMC testing, many anechoic chamber ISTFs have excellent threat simulation capabilities. This affords the test team the opportunity to verify the performance data from previous laboratory testing using free-space RF signals with the actual aircraft equipment and in the presence of other onboard systems operation (direct signal injection is also an option). It also represents an opportunity to fine tune mission data before proceeding to flight test.

#### 2.2.2.2.3 *Installed System Flight Testing*

In one respect flight testing represents the pinnacle of realism for EW receiver testing. The SUT is operating in its intended environment with the aircraft in a flight configuration (landing gear up, engines operating, etc.), using aircraft generated power, in the presence of other operating onboard systems, and in the real-world electromagnetic environment (including civilian RF transmitters). OARs have a variety of high-fidelity simulated and actual threat radar systems providing the best available representations of those threat systems. Proper use of laboratory and ground test facilities minimises unexpected results in flight test.

The benefits and drawbacks of OARs are given in Chapter 6. The limitations of OAR testing include the limited numbers of simulators and actual radar systems, resulting in limited-signal-density environments. In addition to the cost of operating the test aircraft, the OAR range costs can be substantial. Range availability can also be an issue, particularly for lower priority programmes. These cost and schedule implications require early test management consideration. See Figure 2-14.



Figure 2-14: Flight Test Advantages and Limitations – (U.S. DoD Photo).

Another consideration involving actual radar systems is that they only represent a single instance of the combat population. If the combat population for a hypothetical radar system is assessed to operate in the 8.0 – 10.0 GHz frequency range and the single radar on the test range operates on a fixed frequency of

8.1 GHz, a large portion of the RF operating range of the radar cannot be examined at the OAR. Integrated test planning across the various test resources should ensure that those areas, particularly in terms of frequency and PRI, should be examined using ground test assets. In particular, the ground testing should cover a representative spread of threat instances to be encountered during DT&E and OT&E flight test.

Another limitation of OAR testing is that unlike the M&S, laboratory, or ISTF environments, where the RF background is totally controlled by the test planners, the OAR ambient RF environment can contain noise and nuisance signals that may affect the test. False alarms can be a significant problem and knowing the ambient signal environment can be useful in analysing unexpected behaviours of the SUT. Most OARs have excellent signal monitoring and recording capabilities to aid in this regard.

False alarm rates are normally specified for receiver systems. Usually the requirement specifies a maximum number per hour. This is a problematic measure. The false alarm rate for any receiver is integrally related to the environment in which it is operating. The limited number of flight test hours available generally makes a statistically meaningful flight test based assessment difficult (unless the performance is very poor).

The OAR provides the highest fidelity representation of the threat systems that a test programme can produce, although ground test facilities are increasingly able to generate high-fidelity threat representations. Frequently, testing will be conducted against each individual radar to establish a performance baseline for that system. Subsequent testing then focuses on the system performance in more dense multiple signal environments.

A major advantage of OAR EW receiver testing is that test aircraft are always in the far field relative to the simulated threat radar systems. This is particularly applicable when addressing MOPs that directly relate to installed antenna performance. AOA measurement error and ranging error are related MOPs.

The highest priority OAR threat simulators and radars used in support of a test programme should be those with the most relevance to the operational mission of the host aircraft. However, other less operationally relevant emitters should be considered when they allow the test team to examine how the SUT handles different portions of the frequency spectrum, polarisations, and waveforms. Airborne surrogate threat systems can also provide insight about system performance at elevation angles that otherwise could not be examined, e.g., high look-down elevation angles.

Performance estimates for MOPs such as response time, correct initial identification percentage, and correct beam correlation are generally available from ground and laboratory testing. These MOPs can be evaluated concurrently in flight using a series of profiles.

The flight test profiles describe how the aircraft will fly from a defined initial point to the end point specifying airspeeds, altitudes, and any manoeuvres. Corresponding mission and flight cards will describe how the simulated threat radar(s) will operate and how the SUT will be configured. A typical mission card will specify which radar systems will participate on the run, when they will be active and how they will operate their constituent radars (acquisition, TT, and MG) in terms of modes, frequencies, PRIs, etc. The aircrew will also have a flight card identifying the SUT configuration in terms of MDF and modes. The flight card should also inform the aircrew of the expected behaviour of the system in terms of which symbols should appear and where they should appear.

The flight profiles for an RWR test will typically begin at about twice the maximum engagement range of the radar and fly through the heart of the engagement envelope of the threat system. Throughout the run the radar will cycle through a series of scripted mode changes. Sometimes several profiles will be used to evaluate performance at different aspects and ranges. Data collected concurrently on these runs can be used to evaluate key MOPs such as response time, initial correct identification percentage, correct beam correlation percentage, and AOA error. Ranging error can also be evaluated concurrently.

Human factors considerations are also important. The symbology should be clear and should transition smoothly on the display in a manner that accurately represents the threat activity. Audible tones and cues should be clear and sufficiently loud to alert the crew.

### **2.2.2.3 Operational Test and Evaluation**

OT&E focuses on the ability of the military end user to effectively employ the weapon system under realistic combat conditions. It also evaluates the operational suitability of the weapon system. Reliability, maintainability, and supportability are among the most important aspects of a fielded RF receiver system and these are primarily evaluated during OT&E.

One of the most important suitability considerations for a fielded receiver system is mission data reprogramming. The military end user must be able to receive and review intelligence data to determine if a mission data change is required, such as when a threat system is found to be operating on a previously unknown frequency. A very important aspect of an operational suitability evaluation is the ability of the military end user to make necessary mission data changes, rapidly distribute them to operational units in forward locations, and install them on the aircraft.

## **2.3 MISSILE WARNING SYSTEMS**

All missile types pose a threat to military air platforms. In particular, passively-guided, IR-directed missile systems pose a major threat. The most common of these are Man Portable Air Defence Systems (MANPADS). They have accounted for the majority of aircraft combat losses over the last 30 years. Detecting missile launches, warning aircrew of this threat and cueing countermeasure employment is one of the most challenging tasks facing the ES community. Missile Warning Systems (MWS) are designed to detect these missile launches and, in the case of the MWS sub-categories Missile Approach Warners (MAW) and Missile Launch and Approach Warners (MLAW), their approach. The wide proliferation of lethal, relatively inexpensive, man-portable threat systems and the increased level of terrorist activity in recent years have led toward equipping ever more military aircraft with MWS.

### **2.3.1 MWS Technologies**

There are three types of MWS technology:

- Active RF – Pulsed Doppler (RF-PD), e.g., ALQ-156;
- IR, e.g., DDM-Prime; and
- UV, e.g., AAR-54(V).

There is no single technology that is yet fully adequate for all aircraft roles, missions, scenarios and operational theatres. The main benefits and drawbacks of each technology is summarised in Table 2-2.

Table 2-2: Summary Comparison of MWS Technologies.

MWS Type	ADVANTAGES	DISADVANTAGES
RF-PD	<ul style="list-style-type: none"> <li>Measures distance and speed of approaching missile, enabling accurate Time To Impact (TTI), and thus aiding optimum countermeasure employment.</li> <li>Tracks the missile all the way to impact.</li> <li>Not as sensitive to weather conditions as IR and UV MWS.</li> </ul>	<ul style="list-style-type: none"> <li>Limited range compared to IR and UV MWS due to practical levels of RF and prime power, cooling, volume and cost constraints.</li> <li>‘Beaconing’ effect can allow MWS RF transmissions to be detected and utilised by threat weapon targeting systems, especially those using modern ‘digital’ receivers.</li> <li>Cannot measure DOA accurately, so cannot cue DIRCM systems or optimise flare/chaff dispensing on basis of DOA.</li> <li>Potentially vulnerable to hostile jamming and mutual interference from formation flyers, although radar ECCM and synchronisation techniques are effective.</li> <li>Small, low RCS missiles could lead to late detection and countermeasure cueing.</li> <li>Generally higher mass, volume and prime power than IR and UV MWS.</li> <li>Integration more difficult than passive MWS due to need for RF interoperability with other on-board emitters and receivers.</li> </ul>
IR	<ul style="list-style-type: none"> <li>Longer detection range than RF-PD and, at altitude (where there is little ground clutter) than UV MWS.</li> <li>Good DOA for DIRCM cueing, presuming enough sensors.</li> <li>Generally lower mass, volume, prime power than RF-PD MWS.</li> <li>Passive system, so no EMCON issues.</li> <li>Relatively easy installation and integration compared to RF-PD MWS.</li> <li>Dual-band (‘two-colour’) IR MWS give improved performance.</li> </ul>	<ul style="list-style-type: none"> <li>Relatively high FAR compared to RF-PD and UV MWS. Needs extensive ‘false threat signal database’ and complex processing to cater for large natural (solar) and man-made IR clutter.</li> <li>Generally higher mass, volume and prime power than UV MWS.</li> <li>IR sensors require cryogenic cooling, adding to mass, volume, prime power and cost when compared to UV MWS.</li> <li>TTI is algorithmically calculated, rather than measured as in the RF-PD case, leading to sub-optimal cueing of time-critical countermeasures.</li> </ul>
UV	<ul style="list-style-type: none"> <li>Greatest benefit at low operational altitudes for use against short range SAMs launched from modest ranges.</li> <li>Longer detection range than RF-PD MWS.</li> <li>Better FAR performance than IR MWS, especially in the Solar Blind UV region, where there is little clutter.</li> <li>Good DOA for DIRCM cueing, presuming enough sensors.</li> <li>Generally lowest mass, volume and prime power of the three technologies.</li> <li>Passive system, so no EMCON issues.</li> <li>Relatively easy installation and integration compared to RF-PD and IR MWS.</li> </ul>	<ul style="list-style-type: none"> <li>Cannot detect a burnt-out, i.e., coasting, missile.</li> <li>Modest detection range compared to IR MWS.</li> <li>Cannot provide range but can derive TTI from rapid increase in amplitude of approaching missile’s signal.</li> </ul>



Around the time of Issue 1 of this Handbook, there were about the same number of RF-PD and passive (IR/UV) MWS either in service or under development. At that time, IR and UV systems suffered from much higher False Alarm Rates (FAR) than RF-PD systems. In recent times technology developments have led to the trend in MWS toward IR/UV technology, for a variety of reasons including FAR improvements, cooling and power requirements, EMCON and cost. RF-PD technology, however, being radar-based, continues to provide the most accurate missile speed, Time To Impact (TTI) and Range to Impact, which are necessary to optimise the timing of flare/chaff and other countermeasures appropriate to the engaging missile type. Set against this is the IR- and UV-based systems' superior detection range.

The technically optimum MWS would likely be a combined RF and IR/UV system, with the latter passively cueing the active RF RF-PD system in order to minimise EMCON hazards. Generally, such a solution is, in effect, the same as fitting two MWS to an aircraft. This poses significant power, volume, mass and installation constraints, especially on fighter-sized aircraft, and is also often unaffordable.

Given the increasing predominance of IR and UV MWS across NATO Nations, the remainder of Section 2.3 concentrates on passive MWS. Many EW T&E aspects covered therein are equally applicable to any of the three MWS technology types. Key differences concern the method of stimulating a RF-PD MWS when compared to passive MWS testing:

- RF target generators, similar to those used for FCR testing, are used during SIL/HITL/ISTF T&E.
- Flight testing of MWS performance can include:
  - Missiles fired captive on rocket sleds, with overflying aircraft carrying the RF-PD MWS.
  - Firing artillery shells in a carefully controlled trajectory to appropriately approach an overflying aircraft's trajectory so as to trigger missile warning declarations by the MWS.

### **2.3.2 MWS Components and Operation**

Passive-threat warning systems are designed to detect the EM radiation from the rocket motor of the threat missile. Detection can occur due to the rocket motor ignition (launch detection) or by detection of the burning motor and body heating effects during fly-out (in-flight detection). Most modern systems employ sensors that use a combination of the two types of detection. Figure 2-15 shows a simplified MWS block diagram.

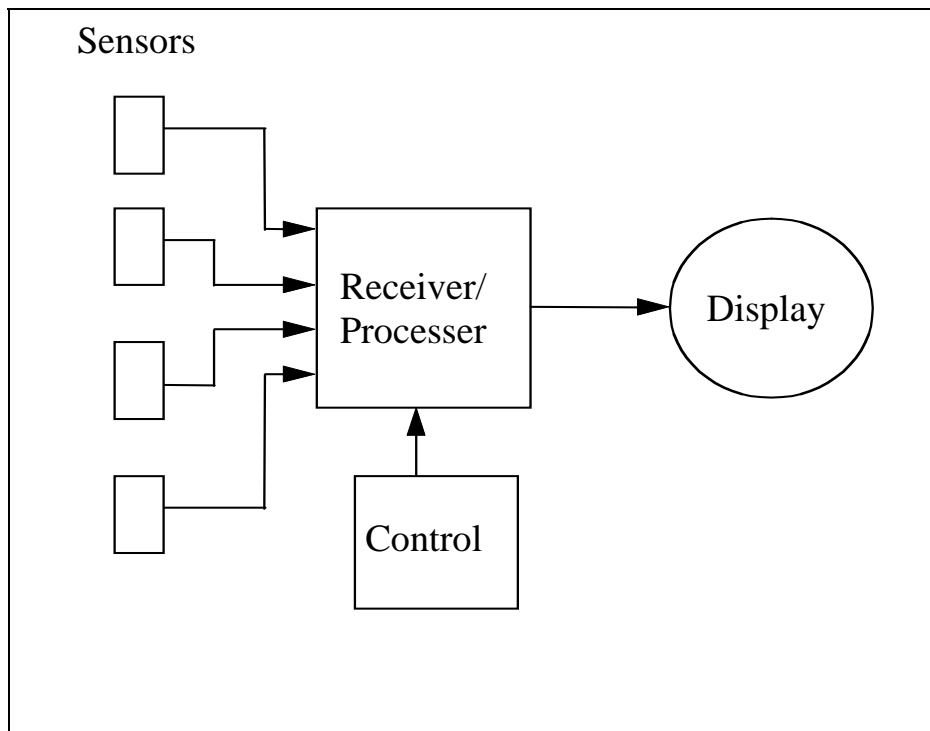

Figure 2-15: Simplified MWS Block Diagram.

MWS face the classic probability of detection versus probability of false alarm trade off. The MWS detectors must be sensitive enough to rapidly and reliably detect the missile's EM signatures and provide either the aircrew or, if in automatic mode, the Defensive Aids Suite's (DAS) countermeasures element sufficient time to react and cue an effective countermeasures response. The system must, at the same time, distinguish an actual missile launch signature from the extremely cluttered electromagnetic background. A false alarm occurs when background radiation produces an alarm in the MWS without the presence of a missile launch.

Modern MWS employ several techniques to minimise false alarms. These techniques fall in into three basic categories and can be used in combination:

- **Spectral** – Analyses specific portions of the EM spectrum to ensure the detection is consistent with the spectral signature of an actual rocket motor.
- **Temporal** – Examines the signal amplitude of a detection over time. As a missile closes in on a target, the range between the missile and the target will decrease while the signal amplitude received by the detector should increase exponentially.
- **Kinematic** – Compares the expected spatial behaviour of a missile on an intercept path with the spatial behaviour of a detection. A missile on a collision course with a target will have very small angular movement in the inertial reference frame (as opposed to the aircraft body axis reference frame).

### 2.3.2.1 Sensor

Passive MWS fall into two broad sensor categories: scanning and staring. IR passive warning systems were first developed over 30 years ago. Present day systems can use either scanning or staring sensors. These systems normally operate in the mid-IR (4 to 5 micrometers wavelength) or the UV bands. Scanning systems provide high-resolution direction-of-arrival information that can optimise countermeasures employment.



However, they generally give up some processing capability because the relatively long scan period can prevent the MWS from detecting the signature characteristics needed to identify the threat. Staring systems continuously cover large fields of view (up to 90 degrees) continuously. This can reduce sensitivity because the system is monitoring a larger area.

The UV portion of the electromagnetic spectrum features lower background noise than the IR region, with good signatures from missile rocket motors. These sensors are typically low-cost, simple photo-multiplier devices that are very rugged. They are typically staring, wide field-of-view (90 degrees or more) sensors. Figure 2-16 shows the uninstalled MWS components and a typical sensor installation.



**Figure 2-16: Top: AN/AAR-54 Electronic Unit and Sensors – (Courtesy of Northrop Grumman Corp.); Bottom: Aft Missile Warning Sensor Installation on a C-130 – (USAF Photo).**

### 2.3.2.2 Processor

Threat detection algorithms are usually based upon a number of criteria. Signal-to-noise ratio is a fundamental parameter. The MWS looks for a signal that exceeds the background signal level from the environment, for signal stability and possibly a particular signal amplitude growth which is characteristic of an approaching threat. It may also look for other time-dependent characteristics such as an ignition pulse followed by a short time delay before main motor ignition, typical of shoulder-launched SAMs.

MWS algorithms must differentiate between a complex battlefield EM environment and an approaching missile. It must also correctly distinguish a missile that is targeting the host aircraft from one that is approaching but not targeting it, i.e., one launched at another aircraft. These are very subtle distinctions.

### 2.3.2.3 Display

A standalone MWS will have a very simple display providing audio and visual information. The audio information consists of tones to alert the pilot to a new threat and the visual information will be some estimate of the Direction Of Arrival (DOA) of the approaching threat, usually only with quadrant resolution. An integrated MWS will most commonly use the MFD or Head Up Display (HUD) to provide the pilot with missile warning information. However, the displayed information may not be any more sophisticated than a few simple tones and quadrant DOA information.

## 2.3.3 MWS Testing

MWS testing parallels RF receiver testing in many respects, but differs in some important ones. The primary difference between RF receiver testing and MWS testing is that RF receivers are designed to detect and process active manmade signals associated with a weapon system, while missile warning systems are designed to detect the EM signature of a rocket motor and discriminate the signature from the background EM environment.

The MWS system-level performance testing requires exciting the SUT with a signal that will produce a threat indication. There are three common methods:

- Stimulators;
- Missile plume simulators; and
- Actual rocket motors.

Stimulators are the lowest fidelity means of exciting a system. They do not necessarily represent a missile launch signature, but have sufficiently representative EM signature characteristics to produce a response from the MWS. Different MWS employ different false alarm rejection methods and testers must be aware of them to ensure that the stimulator is not rejected by the MWS (at least in a way that will compromise the test objective). Static stimulators require the test aircraft to fly very constrained profiles to avoid triggering the kinematic false alarm rejection logic. Stimulators are very useful for system flight line checkouts and integration testing where high-fidelity simulation is not required.

Missile plume simulators provide a high-fidelity temporal and spectral representation of a missile launch. The Joint Mobile Infrared Countermeasures Test System (JMITS) shown in Figure 2-17 is an example of a system incorporating IR and UV missile plume simulations.

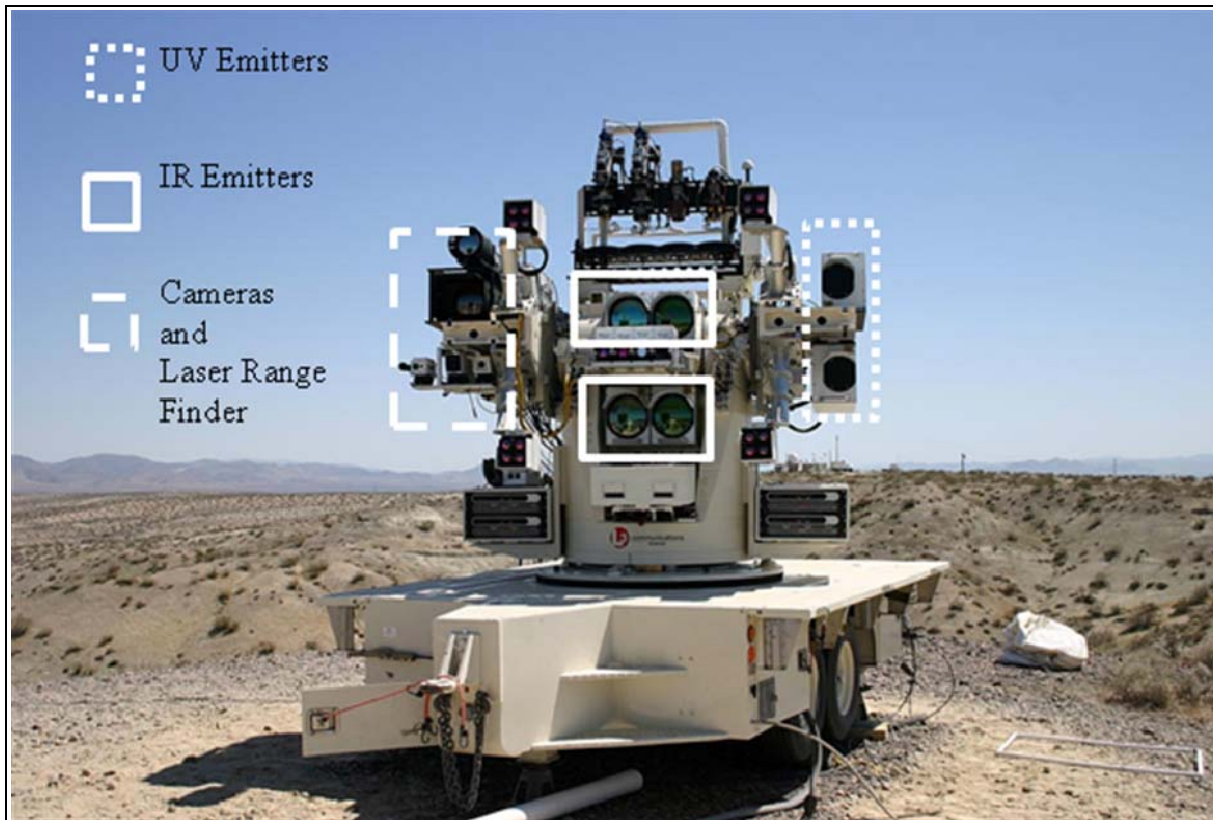

**Figure 2-17: Joint Mobile Infrared Countermeasures Test System – (U.S. DoD Photograph).**

There are several methods of simulating dynamic behaviour. One involves a string of pyrotechnic devices or lamps with the appropriate spectral characteristics. Each device is sequentially activated along the string. This sequential activation produces an apparent motion simulating a missile launch and fly out. If the test aircraft flies an appropriate flight path, the geometry will approach that of an intercept course. Dynamic missile plume simulators are under development. These systems will be towed by a support aircraft and provide high-fidelity temporal and spectral representations with the added capability of realistic kinematics.

Actual missile firings can either be performed using captive missiles on a sled track or live fires. The captive missile launches using a sled track is a similar approach to “string of lamps”. The test aircraft can fly low over the captive missile launch and simulate an intercept geometry. Live missile fire testing, where remotely piloted vehicles or other unmanned platforms are used to carry the MWS, tests the system in as close to a tactical environment as possible.

### **2.3.3.1 Uninstalled MWS Testing**

Uninstalled MWS DT&E allows system developers to evaluate system level performance without requiring installation on or integration with the host platform. Testing in this context includes use of cable cars and flying test beds, where the MWS hardware is present but not usually in an aircraft configuration.

#### *2.3.3.1.1 MWS Component Testing*

The manufacturer tests individual MWS hardware and software components during system development, such as uninstalled sensor field-of-view and detector sensitivity. The processor algorithm optimisation process begins with SIL testing where sensor output data from actual flight testing are recorded and

injected into the processor. This allows for repeated tests against a wide variety of backgrounds and atmospheric conditions without actually flying.

### 2.3.3.1.2 MWS System-Level Testing

System-level testing focuses on MWS ability to distinguish missile launch signatures from background clutter and generate a timely alarm. It can be conducted in SILs, on flying test beds, or on cable cars. A major consideration in MWS development is collecting background environment data to optimise detection and false alarm rejection algorithms. Background testing is conducted using either a flying test bed or the intended host platform to collect environmental background data using the MWS sensors. When false alarms occur, the test team will try to identify the sources and collect as much data as possible for analysis. On false alarm analysis completion the manufacturer will modify algorithms to eliminate or at least minimise the number of false alarms. A database of responses is maintained for future analysis.

Cable car testing is a special case of ground testing where the SUT is exposed to actual missile launches in a dynamic environment. An instrumented MWS is installed on a cable car with a heat source that an IR-guided missile can track. The heat source is commonly suspended some distance below the cable car to reduce the chance of the missile impacting it and the MWS. The cable car is then pulled across a valley, presenting the missile with a realistic target. When the desired test conditions are achieved, a gunner, posted a specified distance down the valley, fires a missile and the MWS response is recorded. Figure 2-18 illustrates the concept. The primary benefit of this type of testing is that an actual missile launch and fly out satisfies the spectral, temporal, and kinematic requirements for a valid declaration.

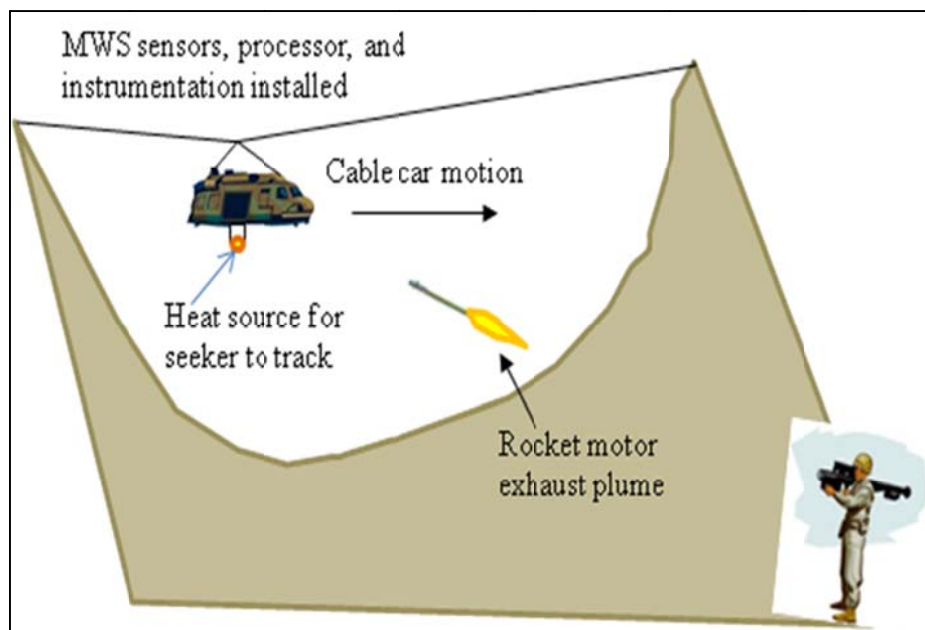

Figure 2-18: Cable Car Test Setup.

### 2.3.3.2 Installed MWS Testing

Much of the required MWS development and testing can be accomplished without having the MWS installed on a production representative aircraft. The final phase of MWS testing should focus on its integration with other aircraft systems and platform-specific installation characteristics, such as field of view.

Ground testing using stimulators to actuate the MWS can be used to ensure that the system has been properly installed and integrated with other aircraft systems. This type of testing is a good way to identify and correct system design deficiencies before flight testing.

Ultimately, the DT&E programme should produce results that characterise the installed MWS performance. This evaluation should focus on system's ability to detect and declare threats, warning time, false alarm susceptibility, and flare dud detection. Mobile missile plume simulators provide a valuable tool for evaluating the MWS performance in a variety of background and atmospheric conditions. This testing is often accomplished as part of an end-to-end test with countermeasures systems such as flare dispensers and directed IR countermeasures systems (arc lamp- or laser-based).

The proliferation of MANPADS and the threat they pose to modern aircraft has driven an increased demand for MWS installations on ever more platforms. Commonly, a MWS that has been developed and fielded on one platform will be chosen as the MWS for a new platform, thereby reducing development costs. T&E efforts of this nature should then focus on integration with multiple aircraft systems and provide detailed platform-specific installation characteristics.

As with other systems, reliability and maintainability are determined using statistical data acquired over time. Re-programmability is the capability of changing parameters or algorithms in the system to meet new threat scenarios, while minimising the costs of upgrading or replacing hardware.

## **2.4 LASER WARNING SYSTEMS (LWS)**

Airborne laser warning systems are currently provided mainly for low and slow aircraft, including helicopters, although some are also being fitted to fast jet aircraft. The primary threat systems of interest are AAA systems employing a laser range finder and laser beam-riding missiles.

### **2.4.1 LWS Components and Operation**

An LWS is functionally similar to the MWS shown in Figure 2-15. In general, LWS consist of sensors to detect the laser signal, a processor to analyse the data, and a mechanism to warn the pilot. Laser detectors are commonly integrated with the sensor modules of MWS and often share a common processor. Typically, 6 – 8 sensors are required to provide spherical coverage. Figure 2-19 shows a typical LWS.



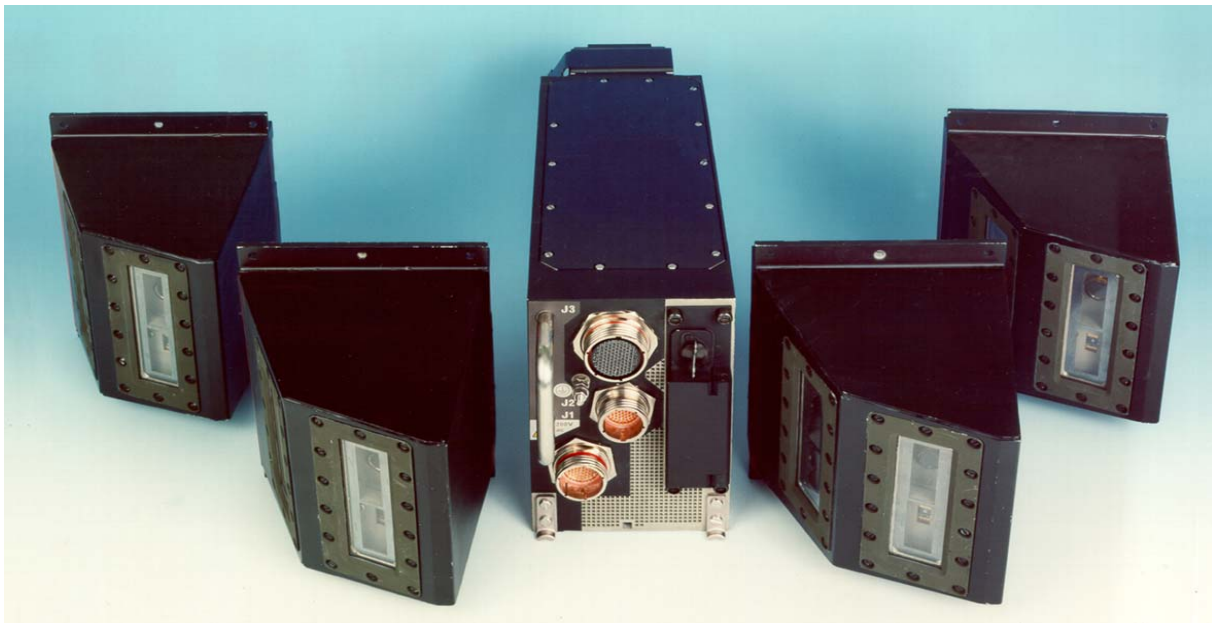

Figure 2-19: 1223 Laser Warning Receiver System – (Courtesy of SELEX GALILEO).

#### 2.4.1.1 Sensors and Receivers

Sensor designers must consider several characteristics unique to lasers. Lasers generally operate either on a fixed wavelength or are tuneable over a relatively small wavelength range. The particular operating wavelength is determined by the lasing material. Additionally, laser beams are coherent light sources with very little beam divergence, unlike radar. When a laser is illuminating the target aircraft, the laser beam may or may not directly illuminate the sensor aperture and the sensor must be able to detect the laser energy scattering off of the airframe or through the atmosphere. Detecting atmospheric laser scatter in the presence of intense background clutter presents a significant challenge.

#### 2.4.1.2 Processor

False alarm discrimination, while still an important consideration, is less challenging to LWS than to MWS. Laser beams are man-made phenomena and are unlikely to be mistaken for anything else. A laser beam illuminating an aircraft in a combat environment is a strong indicator of hostile intent.

#### 2.4.1.3 Display

Laser warning displays are commonly integrated with MWS displays or other integrated threat displays. The displayed information is similar in structure to MWS symbology.

### 2.4.2 LWS Testing

Many of the same concepts discussed in the MWS testing section apply to lasers as well. LWS testing requires stimulating the laser sensor with a signal of sufficient fidelity to trigger a system response. The level of fidelity is driven by the test requirement. In the most basic case, flight line integration testing and system checkouts can be accomplished with a laser operating on a suitable wavelength. In other tests, the pulsed structure associated with a beam-riding missile may be required.

#### 2.4.2.1 Uninstalled LWS Testing

The uninstalled testing is similar in concept to MWS testing.

#### 2.4.2.1.1 LWS Component Testing

Laboratory testing measures several critical parameters. The sensitivity of the sensor at various operationally relevant wavelengths directly relates to the maximum range at which a threat system can be detected. Off-axis sensitivity is also a key consideration for laser warning sensors because they must be able to detect energy scattered through the atmosphere and/or off the airframe. Dynamic range is also an important consideration because the sensor must detect the very low energy levels associated with atmospheric scattering as well as the direct illumination of the aperture by the laser beam. Since receiver sensitivity is degraded when operated in bright sunlight, sensitivity is also measured in outdoor tests; however, the measurements obtained in this manner are not as accurate as laboratory measurements because atmospheric scintillation can cause fluctuations in the received power density.

#### 2.4.2.1.2 LWS Level Testing

Flight tests are conducted to determine if there are problems unique to the flight environment. Significant testing can be accomplished without having the system installed on a production aircraft. Flight tests on a flying test bed are particularly useful in evaluating the maximum detection range and false alarm susceptibility in an operational environment. Maximum detection range is determined in airborne tests by flying the aircraft both towards and away from the threat, and noting where detection is obtained or lost.

#### 2.4.2.2 Installed LWS Testing

Flight tests must be conducted to verify that neither the installation nor integration with other avionics has significantly altered system performance. Of particular note to installed system testing are compatibility with other aircraft systems, EMI, field-of-view restrictions, scattering of laser radiation from aircraft surfaces, and aircrew operational interface. Airborne tests are also conducted to ensure that the receiver can perform in an aircraft environment (vibration, temperature, pressure and EMI/EMC). Atmospheric scintillation can affect the AOA accuracy, and aircraft parts can affect the field of view. Even for quadrant detection systems, it is important to determine how the receiver handles the transitional regions between quadrants.

The laser beam rider missile is an increasing threat to aircraft. Beam rider detection presents a special challenge because of the extremely low irradiance levels involved. A beam rider simulator should be provided for ground and airborne tests; one that can produce not only the proper wavelength, but also the proper pulse coding because detection algorithms used to get good sensitivity can be affected by the pulse code format.

## 2.5 REFERENCES

- [1] Tsui, J.B., "Microwave Receivers with Electronic Warfare Applications", Raleigh, NC, SciTech Publishing, Inc., 2005 (ISBN 1-891121-40-5), pp. 2-3.
- [2] Tsui, p. 58.
- [3] Tsui, pp. 58-62.
- [4] "Encyclopedia of Aerospace Engineering (2010)", Edited by Richard Blockley and Wei Shyy. John Wiley & Sons, Ltd. ISBN: 978-0-470-75440-5. Volume 7, Chapter 376 – Pywell, M. Electronic Warfare and Defensive Aids Systems Design and Development.
- [5] Anderson, R.B., Bieling, R., Strombo, G., Hunt, D. and Brown, F. "Threat Correlation to Ground Test Stimulators at the Benefield Anechoic Facility (BAF)", U.S. Air Force T&E Days, 6-8 December 2005, Nashville, Tennessee, AIAA 2005-7659.



## 2.6 FURTHER READING

Adamy, D.L., EW 101: “A First Course in Electronic Warfare”, Norwood, MA, Artech House, Inc., 2001, (ISBN 1-58053-169-5).

Adamy, D.L., EW 102: “A Second Course in Electronic Warfare”, Norwood, MA, Artech House, Inc., 2004, (ISBN 1-58053-686-7).

Golden, A., “Radar Electronic Warfare”, New York, New York, American Institute of Aeronautics and Astronautics, Inc., 1987, (ISBN 0-930403-22-3).

Hecht, J., “Understanding Lasers: An Entry Level Guide”, Hoboken, NJ, John Wiley & Sons, 2001, (ISBN 0-7803-1005-5).

NATO Industrial Advisory Group SG-66 – Future Electronic Support Solutions – Digital Solutions – Final Report. NIAG-D/ASG(2001)7, November 2001.

NATO Industrial Advisory Group SG-79 – Emitter Location System (ELS) and Data Links for SEAD – Final Report. NIAG-D(2006)0009, AC/224-D(2006)0010, February 2006.

Schleher, D.C., “Electronic Warfare in the Information Age”, Norwood, MA, Artech House, Inc., 1999, (ISBN 0-89006-526-8).

Skolnik, M.I., “Introduction to Radar Systems, 3<sup>rd</sup> Ed”, New York, NY, McGraw-Hill, Inc., 2001, (ISBN 0-07-290980-3).

Tsui, J.B., “Digital Techniques for Wideband Receivers, 2<sup>nd</sup> Ed.”, Norwood, MA, Artech House, Inc., 2001, (ISBN 1-58053-299-3).

Wiley, R.G., “*ELINT – The Interception and Analysis of Radar Signals, 2<sup>nd</sup> Ed.*”, Norwood, MA, Artech House, Inc., 2006, (ISBN 1-58053-925-4).

Holt, O., Technology Survey – Missile Warning Systems. Journal of Electronic Defense, May 2010, pp. 61-67.



## Chapter 3 – T&E OF EA SYSTEMS

### 3.1 INTRODUCTION

This chapter addresses the T&E of the following types of EA systems:

- RF Self-Protection Jammers, RF Support Jammers and RF Towed Decoys;
- Active Infrared Countermeasures Systems and Countermeasures Dispensing Systems;
- Low Observable Systems; and
- Directed Energy Systems.

Figure 3-1 shows a sampling of EA systems.



**Figure 3-1: Electronic Attack System Examples – (US DoD Photos, except the ALE-55 Towed Decoy, which is Courtesy of BAE Systems).**

Each section addresses the general function, concepts of operation, and components of the subject EA system. The T&E of each type of system is also addressed at the component, sub-system, and integrated system levels. System level testing is approached from two aspects: uninstalled and installed. Uninstalled testing refers to all system and sub-system testing that is not conducted on the intended host platform. Installed system testing is that accomplished with the system installed on the intended host air vehicle.

### 3.2 RF SELF-PROTECTION JAMMER

SPJ are defensive EA systems that protect their host platform from hostile radar directed weapons systems. These systems can either be installed internally within the airframe or carried externally in a pod.

#### 3.2.1 Radar Operation and Jamming Types

Understanding how radar systems work in light of the countermeasures that will be employed against them is important. The two categories of radar systems that will be discussed are TT radars supporting weapon direction and search or surveillance radars. Semi-active missile seekers are special cases of TT radars. Radar systems supporting weapon direction require very accurate target state information (azimuth angle, elevation angle, and range and/or radial velocity).

Radars can be classified as one of three types: Low Pulse Repletion Frequency (LPRF), Medium PRF (MPRF), and High PRF (HPRF) radars – including CW radars for the purpose of this discussion. LPRF radars track targets in angle (azimuth and elevation) and range. MPRF radars track targets in angle, range, and radial velocity. HPRF and CW radars track targets in angle and radial velocity. Some HPRF and CW radars also employ sophisticated techniques to measure target range. Table 3-1 summarises the characteristics of each radar type.

**Table 3-1: Radar Types and Performance Characteristics.**

<b>Radar Type</b>	<b>Range Performance</b>	<b>Doppler Performance</b>	<b>Comments</b>
<b>LPRF</b>	Unambiguous	Ambiguous	Generally cannot achieve good unambiguous Doppler performance
<b>MPRF</b>	Ambiguous	Ambiguous	Can achieve good unambiguous range and Doppler performance but requires the use of sophisticated waveforms and processing
<b>HPRF, including CW</b>	Ambiguous	Unambiguous	Can achieve good unambiguous range performance but requires the use of sophisticated waveforms and processing

The following discussions focus on LPRF and HPRF radars. Countermeasures directed at tracking radars aim to disrupt their TT capabilities by corrupting their target state information, thereby degrading or denying weapon employment.

A conventional low PRF radar system transmits a pulse of energy and measures the time that the pulse takes to make the round trip from the radar to the target and back. Since the radar pulse is travelling at the speed of light, the range to the target can be determined, but it is important to remember that the fundamental measurement is time-based. Similarly, pulse Doppler and CW radars measure the Doppler-shifted frequency of the signal returning from the target relative the transmitted frequency. This shifted frequency can be calibrated to the radial velocity of the target, but it is crucial to remember that the radar isn't measuring radial velocity, it is actually measuring frequency. Consequently, countermeasures directed at conventional pulsed radars create range errors by corrupting the time-based measurements of the radar. Similarly, countermeasures directed at pulse Doppler radars create radial velocity errors by corrupting the frequency measurements of the radar.

Radars can also be classified as coherent or non-coherent types. The coherent ones can measure Doppler with good accuracy but they need a constant fingerprint (RF and PRF) during the integration interval (a few milli-seconds) and can, due to that, be more sensitive to jamming.

Angle tracking is the most important of the tracking domains for TT radars associated with weapons systems. Many types of weapons systems can prosecute a successful target engagement in the presence of large range or velocity errors. Essentially, this is because the radar is still providing a line of sight to the target to the fire control system. Even relatively small angle tracking errors can sufficiently degrade the weapon system's performance to prevent a successful engagement. The most effective jamming result against a TT radar is to create an angle tracking error sufficiently large that the system breaks lock on the target. A break lock requires the threat system to re-acquire the target and re-initiate the weapon employment process.

TT radars employ two basic types of angle tracking mechanisms: Amplitude Modulation (AM) and monopulse. The AM techniques, such as sequential lobing, Track While Scan (TWS), and Conical Scan (CONSCAN) are mostly used by older radar systems. These techniques employ a scanning radar beam or series of beams to sequentially sample the target amplitude returns. When the boresight of a beam is pointed at the target the radar will receive the largest amplitude return, and when the boresight moves away from the target the amplitude will drop off. These amplitude variations can be used to produce an error signal and drive an automatic angle tracker. Monopulse angle-tracking radars instantaneously produce amplitude (or phase) errors in the azimuth and elevation channels, as opposed to the AM trackers which do it sequentially. Nearly all modern radars employ monopulse angle trackers and they have a high degree of immunity to AM angle jamming.

Radio frequency defensive EA systems employ active RF jamming transmissions to disrupt the operation of hostile radar systems. These transmissions can be broadly classified as either:

- **Noise Jamming** – Noise jamming attempts to increase the noise power level in the victim radar's receiver thereby decreasing the signal-to-noise ratio and correspondingly its maximum detection range. Figure 3-2 shows several types of noise jamming. Barrage noise spreads the jamming energy over a relatively wide frequency range. This technique has the advantage of covering a large frequency range and does not require any knowledge about the victim radars but at the cost of diluting the jamming power. Spot noise transmits the jamming energy over narrow frequency ranges and can achieve high power levels but requires knowledge of the victim radar's operating frequency. Swept spot noise sweeps a relatively high power signal through a frequency band of interest. This allows high jamming power levels and does not require knowledge of the victim radar, but at the cost of leaving the victim radar un-jammed some portion of the time.
- **Deceptive (or Deception) Jamming** – Deceptive jamming, also known as false target jamming, presents the radar with target-like waveforms with the intent of deceiving either an operator or the automatic detection and tracking features of the radar.

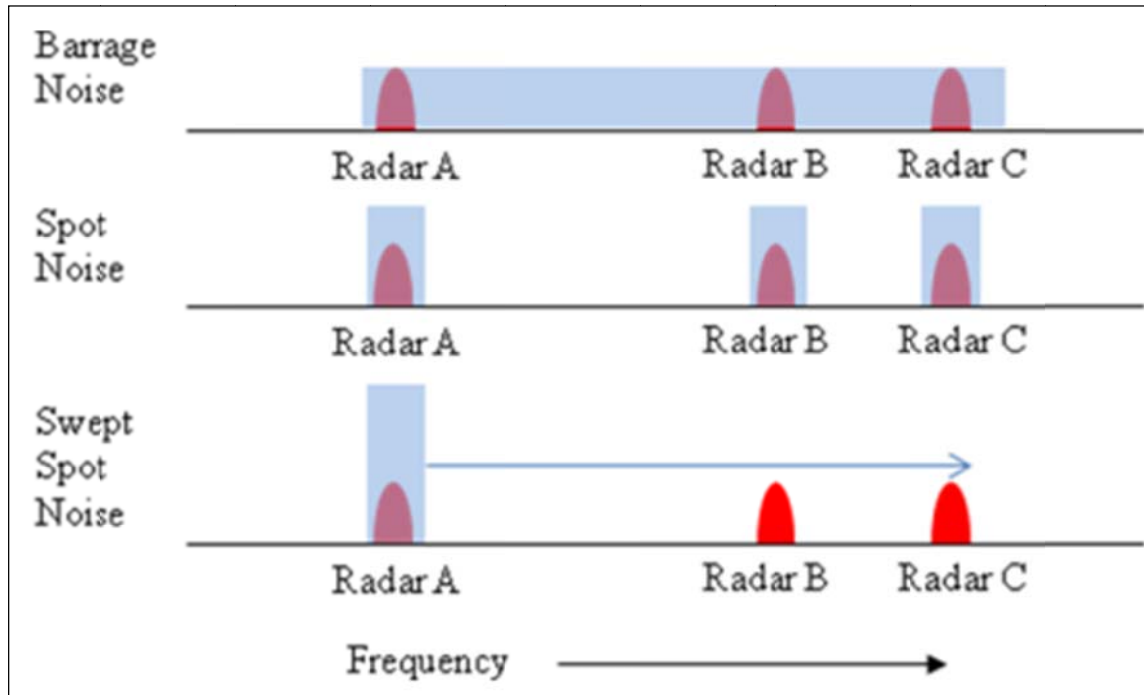

Figure 3-2: Types of Noise Jamming.

### 3.2.2 RFCM System Concepts and Operation

An RFCM system has several basic components. The front end of the system is similar to an RWR and consists of an antenna or an array of antennas, RF transmission lines, and a receiver/processor. In addition to the front end of the system, the RFCM system has a technique generator, a modulator/transmitter module used to modulate and amplify the jamming waveform and the transmit RF transmission lines and antennas. Figure 3-3 is a simplified block diagram of a RFCM system.

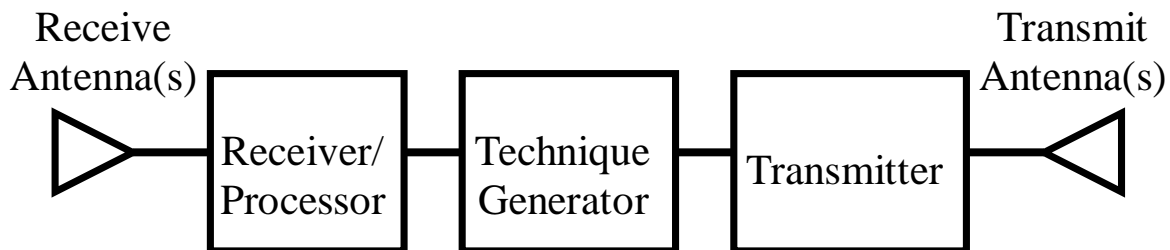

Figure 3-3: Simplified Jammer Block Diagram.

Figure 3-4 shows the individual components of the Advanced Integrated Defensive EW Suite (AIDEWS). AIDEWS is an example of a typical modern self protection jammer; this particular system also performs as an RWR and a controller for other onboard EW systems.



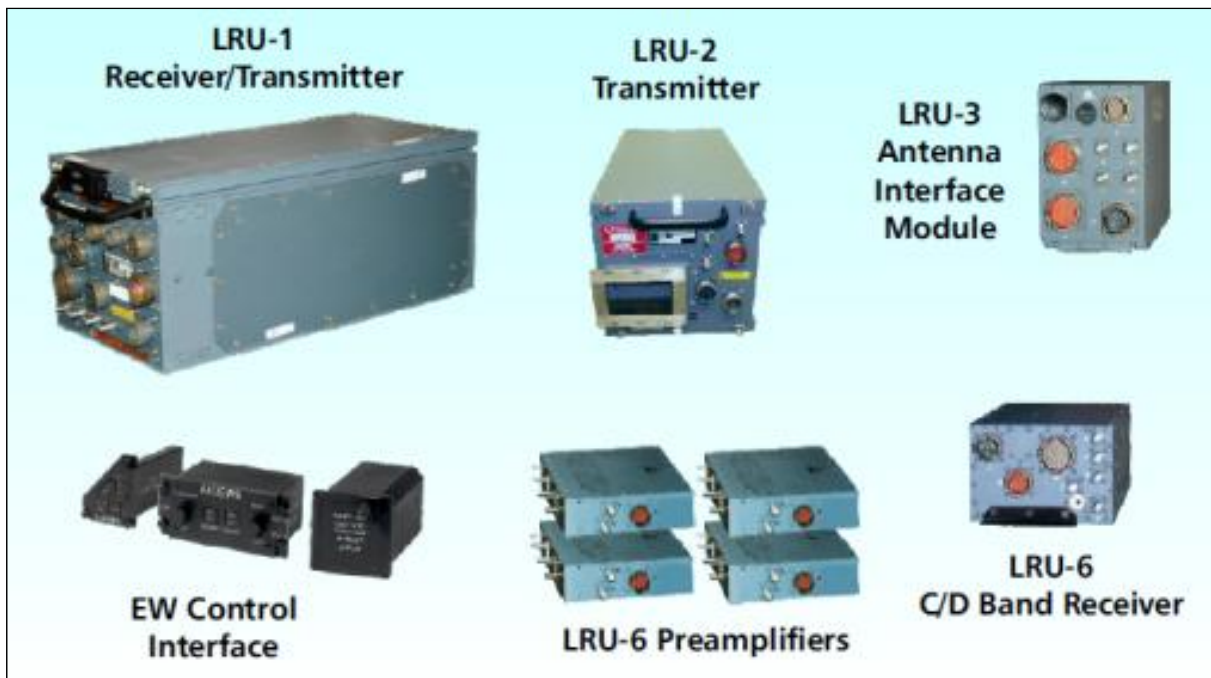

Figure 3-4: Typical Self-Protection Jammer Components – (Courtesy of ITT Corporation).

### 3.2.2.1 RF Front End and Receiver/Processor

The front end of an RFCM system is very similar to an RWR. It must survey the RF environment and, based on its mission data programming, identify, determine the angle of arrival, and prioritise incoming threat signals. All of the discussion in Section 2.2 about receivers applies to RFCM receivers as well.

### 3.2.2.2 Technique Generator and Transmitter

When the processor has identified and prioritised the threat systems in the environment the system will then determine a countermeasures response. The MDF identifies the optimum technique or series of techniques that will be transmitted against the threat system. Most RFCM techniques attack the victim radar's tracking domains: range, Doppler, and angle and the MDF contain the parametric definitions of these techniques.

The technique generator may use oscillators, or a part of the incoming signal, and time, frequency, and/or amplitude to modulate the signal to achieve the desired technique. The transmitter then amplifies and transmits the jamming waveform.

Modern radars employ a variety of EP techniques to improve their signal processing gain and mitigate the effects of hostile EA. Many of the EP features employed by modern radars address the ability to discriminate between the radars' transmitted waveforms and jamming waveforms. Therefore, it is becoming more critical in deceptive (false target) jamming that the jamming waveforms resemble the radar waveforms such that they are not rejected by the victim radar's EP logic. Digital RF Memory (DRFM) technology is increasingly being employed in RF countermeasures systems. DRFM-based techniques allow a jammer to produce very high quality false targets. They do this by sampling the incoming pulses and storing them. The stored pulses retain the nuances of the received pulses, such as phase coherency or intrapulse modulation. These stored pulses can then be modulated and re-transmitted back toward the victim radar.



### **3.2.2.3 Transmit Antennas**

The RFCM system designers employ a wide variety of transmit antenna configurations. Regardless of the transmit antenna configuration it is designed to direct as much jamming energy as possible back toward the threat system. The system may have dedicated transmit antennas or it may timeshare an RF transmission line with the receive system. Dedicated transmit antennas can be as simple as just forward and aft antennas or may be as complicated as multiple electronically steered phased array antennas.

### **3.2.2.4 Displays and Controls**

The aircrew interface usually consists of a control panel for selection of system operating modes and indicator lights identifying the threat environment. Typical operational modes for the jammer consist of standby, receive only, and transmit. Some displays will show which threat systems are being countered.

### **3.2.2.5 RF Management Systems**

SPJ systems transmit high power RF energy that can adversely affect SPJ operation as well as that of other onboard systems. Antenna isolation is an important consideration for EMC. Ideally, the receive antennas on an aircraft would be electrically isolated from the transmit antennas and the receiver would not detect any onboard-generated RF transmissions. However, if there is insufficient isolation to prevent onboard receivers from detecting and processing the transmitted signals, their performance can be affected.

Potential inference examples include the SPJ system detecting, processing, and jamming the fire control radar; the RWR seeing the SPJ system transmissions, misinterpreting them and erroneously displaying threat symbols; the SPJ receiver seeing the SPJ system transmissions and processing them as threats (a condition known as ring around). System designers attempt to optimise antenna placement to meet the system's field of view requirements and to maximise isolation.

An RF management system, such as a blanker, must be employed where insufficient antenna isolation exists to prevent the receiver from seeing the transmitted signals. Installed system testing allows testers to determine if the chosen RF management scheme has been properly implemented. Temporal blankers merely 'turn off' the target receiver when the related transmitter transmits and verifying the correct timing of the blanking pulses is critical. More sophisticated schemes pass operating information from the transmitting system such as frequency and PRF, so that the receiver can identify the transmitted signal and then ignore it.

## **3.2.3 SPJ System Testing**

The discussion from Section 2.2 on RWR testing applies to the receiver aspects of SPJ systems. In addition to the receiver components, the SPJ system has additional components and considerations related to the transmitter portion. There is a significant difference between testing an RWR and testing an SPJ system. The RWR is an open-loop system. It merely monitors the environment and communicates information to the aircrew or countermeasures systems. The SPJ is a closed-loop system, as is the radar system it is attacking. While it surveys the environment in the same manner as an RWR, its purpose is to actively disrupt the behaviour of the threat system.

If the SPJ system is effective, it will cause the threat system and/or its operators to adapt to the jamming and likewise the SPJ system will respond to changes in the threat-system behaviour. This dynamic environment greatly complicates the T&E of SPJ systems. It is imperative that the test team, including the test planners and the analysts, have a thorough understanding of not only how the SPJ system operates, but also how each of the victim radars works and how they are employed operationally.

Two measures that are central to SPJ system T&E are miss distance and Jamming-to-Signal ratio (J/S). These measures are important indicators of overall system performance. Unfortunately, both are difficult

to measure directly and can be difficult to interpret. These measures must be considered throughout the development programme and should be re-evaluated as higher fidelity measurement data becomes available.

SPJ effectiveness is evaluated by its ability to improve the survivability of the host aircraft. This ultimately involves determining the success or failure of an engagement by a hostile weapons system. The success or failure of an engagement is determined by the miss distance of the missile or the bullets in the case of a ballistic system. The degree of survivability improvement afforded by the SPJ can be inferred by statistically comparing the miss distance data collected under the same conditions with the SPJ off versus the miss distance data with the SPJ operating, conditions known as 'dry' and 'wet', respectively.

Since the evaluation involves a weapon miss distance, it can only be performed through M&S or live-fire testing with unmanned aircraft. Live-fire testing provides very useful anecdotal information about the SPJ system effectiveness and performance but, due to the cost, rarely produces enough data to make statistically relevant performance estimates about the population. Operationally, the SPJ system is only one contributor to aircraft survivability. Other contributors include chaff, manoeuvres, and tactics. Since all of these are interrelated it is extremely difficult to cost effectively isolate the specific contribution of the jammer to aircraft survivability.

The relationship between the SPJ system output and its effectiveness is complicated and somewhat counter-intuitive. The J/S ratio is the SPJ system jamming power entering the radar's receiver divided by the target skin return signal power entering the radar's receiver. The J/S ratio is an important measure and it is vital to understand its implications.

The jammer power entering the victim radar's receiver increases as the jammer gets closer to the victim radar. Although it would seem to, this does not result in increased jammer effectiveness, because while the jammer power is increasing, the target skin return signal power is also increasing, but at a much faster rate. Annex C discusses this in more detail. Thus, with all else being equal, the jammer will become less effective as the range to the victim radar decreases. At some point the jamming will become ineffective. The range at which this occurs is called the burn-through range.

An SPJ system can be functionally decomposed and the performance of each component can be determined and evaluated. Key performance measures are good indicators of SPJ system performance. As the performance of each component is better understood, the assumptions underlying the M&S can be refined and the fidelity of the M&S improved. In-depth analysis can take the overall effectiveness requirements and determine how the various components of a given design must perform in order to achieve them. The decomposed requirements identify important performance specifications for system components such as installed system sensitivity and Effective Radiated Power (ERP). The EMC of all RF transmitters and receivers in their installed configurations must be characterised. The EMC test results allow designers to eliminate or mitigate EMI effects.

As with RWRs, SPJ system specifications, testing, and performance assessments can be broken down into three main categories: T&E done on the SPJ system and its constituent components, T&E done on the SPJ system as installed on the host aircraft, and OT&E to determine if the overall system is effective and suitable to perform its intended mission. The SPJ system testing has additional requirements related to the transmitter and related components. The system also requires evaluations that focus on the behaviour of the operators of the victim systems.

### **3.2.3.1 Uninstalled SPJ Component Testing and Performance Assessments**

Uninstalled SPJ testing can be either open or closed loop. Open loop testing is conducted by injecting the SPJ's receiver with simulated RF threat signal(s), to stimulate the processor and transmitters,

and monitoring the output jamming waveform. The SPJ output does not affect the input signal and the effectiveness of the jamming waveforms cannot be evaluated. Closed loop testing includes a representation of TT radar receiver, TT loop, and radar operator, and allows effectiveness to be evaluated.

#### *3.2.3.1.1 Open Loop Component and System Level Testing*

Testing performed at the manufacturer's laboratory facilities is almost always open loop and focuses on individual components' performance and, at the system level, ensuring that SPJ output is consistent with expectations based on the RF input. Receiver and processor component testing is addressed in Section 2.2.

The technique generator should, based on the processor's identification and the received RF threat signal, select and generate the countermeasures technique defined in the MDF. The specific RF output of the technique should be measured to ensure that the frequency, timing, amplitude, and pulse characteristics are consistent with the intended technique. The timing relationship between the input RF signal input and the jamming output signal is critical, especially for false target generators. Additionally, when more than one radar-directed threat system engages the host platform, it is necessary to verify that the system properly prioritises the associated threat signals and correctly assigns the transmitter resources. It is important to ensure that the most lethal threats receive jamming resource priority.

The SPJ J/S ratio spatial coverage should be evaluated on a threat-by-threat and technique-by-technique basis. This allows analysts to determine where the jammer will and will not be effective. While J/S cannot be directly measured in a laboratory, a complete analysis can be performed based on laboratory measurements, modelling results, and other measured characteristics. The J/S is a function of range to the target and these other factors:

- Threat radar system ERP;
- RCS of the SPJ host aircraft; and
- SPJ system ERP.

The threat system ERP is the power directed by the threat radar toward the aircraft carrying the SPJ. It is a function of the radar transmitter power, transmission line losses, and transmit antenna gain. Threat system ERP is commonly obtained from intelligence estimates.

The RCS of the aircraft carrying the SPJ system can be obtained either from software-based predictions or measured at an RCS measurement facility.

The SPJ power directed toward the victim radar is the product of the transmitter output power, the RF transmission line loss, and the transmit antenna gain. Figure 3-5 shows the components of an SPJ transmit path and how ERP is calculated. The transmitter power output can be measured in the laboratory. Transmission line losses can be estimated from waveguide and RF switch characteristics of the system design or measured on the aircraft, if available. Installed antenna gain patterns can either be obtained from either software-based predictions or measured at an antenna pattern measurement facility.



$$\text{Effective Radiated Power (ERP in Watts)} = \frac{P G}{L}$$

Or in decibel form:

$$\text{ERP (dBW)} = P (\text{dBW}) - L (\text{dB}) + G (\text{dB})$$

**Figure 3-5: RF Transmit Path Components and Effective Radiated Power.**

The RF spectrum of the transmitter should be characterised in the laboratory. An ideal transmitter only amplifies and outputs the specific signal injected into it. However, real transmitters often produce ‘extra’ or **spurious signals**. Spurious signals are most likely to occur at harmonics of the injected signal but they may appear anywhere in the spectrum due to limitations and/or errors in system design, manufacture, or installation. These spurious signals waste valuable jammer power and in some cases can be exploited by a threat system’s EP features.

### 3.2.3.1.2 Closed Loop System Level Testing

HITL test facilities generally present the first opportunity to examine the closed-loop SPJ system performance and effectiveness. HITL simulations typically employ high-fidelity threat simulations and sometimes generate realistic simulated displays to support a threat operator in the loop. The simulation also generally employs a scripted aircraft flight path and a dynamic engagement geometry that accounts for the changing RCS and transmit and receive antenna gains, and can be used to generate a realistic J/S ratio throughout the simulated engagement. The operator in the loop is a critical element of the threat system’s EP design. The HITL testing can be used to optimise the SPJ technique design to deceive the man in the loop.

Since HITL simulations incorporate high fidelity threat simulations they can support detailed SPJ performance and effectiveness evaluations. The measures associated with the tracking loops of the radar such as range and/or radial velocity error and azimuth and elevation angle errors can be generated from dry and wet cases and compared to evaluate performance. Simulated missile and projectile fly-out data can also be generated and the dry and wet cases can be compared to evaluate the system effectiveness.

There are a variety of threat system models with varying degrees of fidelity that address threat system behaviour, especially the radar, fire control system, and missile or projectile aerodynamics. Analysts need to understand what the various threat models do and how they work, particularly with respect to how the operator is addressed.

The HITL testing is a cost effective way to generate significant amounts of data. Limitations include a scripted flight path (i.e., the aircraft doesn’t normally react to the engagement, it just flies a predetermined path and the SPJ system is normally operating in a standalone configuration without the effects of other onboard systems). The HITL also provides the best chance to evaluate system performance when a simulated or actual radar system is not available on an OAR.

Another case of system-level closed-loop testing occurs when an SPJ system is rack-mounted, normally in a trailer, and taken to an OAR. The system can then be tested against OAR radar threat simulators to evaluate closed-loop performance. This type of testing is often called pole testing because the receive antenna is mounted on a pole and elevated some distance above the ground to mitigate the effects of multipath and reflections. This type of testing has the advantage of working against a simulated or actual tracking threat radar systems. Limitations include the static configuration and the lack of actual RCS or antenna pattern effects.

### **3.2.3.2 Installed SPJ Testing and Performance Assessments**

Installed-system ground testing is primarily open loop and focuses on aircraft system integration and EMC testing. Integration testing can either occur at the PSI's SILs or on the aircraft. Increasingly, ISTFs are capable of generating high fidelity threat simulations and limited closed loop capabilities.

#### *3.2.3.2.1 Installed-System SPJ Ground Testing*

The PSI will conduct integration testing in their SILs to ensure that the SPJ system properly communicates with other onboard systems. The SPJ manufacturer, as is the case with the RWR manufacturer, normally will emulate data bus traffic. The PSI's SIL will often be the first time that the SPJ will interface with other actual aircraft hardware.

The EMC testing discussed in Section 2.2.2.2.2 also applies to SPJ systems. Additionally, an ISTF can cost-effectively expose the SPJ to high fidelity threat representations such that the end-to-end performance of the installed SPJ can be evaluated in a secure environment. Occasionally, EA technique deficiencies are discovered and can be corrected before moving on to flight testing.

Some ISTFs have developed limited closed loop test capabilities. The test team needs to ensure that the test objectives are tailored to be compatible with the limitations of these capabilities.

#### *3.2.3.2.2 Installed-System SPJ Flight Testing*

Flight testing presents the ultimate 1-versus-1 (1-v-1) closed-loop environment to evaluate the SPJ system performance. The SPJ is normally in a production-representative configuration and all of the testing takes place in the far field (testing will sometimes be conducted in various non-production configurations to support specific development test objectives). The system operates against a high-fidelity simulated threat radar or actual radar system with operators in the loop. The operator is a key EP feature of many threat systems. A well-trained operator can recognise jamming techniques and manually intervene to counter the effects of the jamming and maintain radar track. Operator skill is an important consideration in any SPJ system testing.

Rules Of Engagement (ROE) define operator behaviour during the test, particularly with respect to the EP features the operator is allowed to use. Two of the most common ROE address optical systems and reacquisition procedures. Operators are frequently precluded from using optical systems to aid tracking (a good optical angle track can be used to provide angle information to the tracker in lieu of radar angle track information). This is often done to simulate night conditions. When the jammer is effective and causes the victim radar to break lock, the operator needs to know how he will go about reengaging the target aircraft. This brings up a case where the test team needs to balance test efficiency with realism. The fastest way to reacquire the target is to allow the operator to use the OAR's real-time instrumentation truth data to locate the aircraft. This approach maximises the amount of data collected during limited-range times. The most realistic method is requiring the operator to use the onboard acquisition radar system. The test team must weigh the value of additional data versus the more realistic conditions. The ROE for a given threat system and SPJ system will vary with the specific test objectives. The importance of clearly defined ROE cannot be overstated and the entire test team should be involved in their development.

The performance of an SPJ system can be degraded by the operation of other onboard transmitters, e.g., the blanker may inhibit jammer transmissions when the terrain-following radar is transmitting (the TF radar will generally have priority). Comparing the 1-v-1 performance under similar conditions of the jammer when it is operating alone to its performance in an operationally representative condition (with other onboard systems operating) allows analysts to determine if the RF management system is degrading the SPJ system performance. Multiple-ship operations also need to be considered. For example, the interactions of jammers and fire-control radars within a tactical fighter formation need to be examined to determine potential limitations.

In-flight J/S measurement can be a valuable tool but generally requires specialised, non-operationally representative EA techniques to be loaded in the SPJ systems MDF. One technique, shown in Figure 3-6 delays the EA response from the incident radar pulse by a fixed time period. The separate returns are collected in discrete range gates. Since there are an infinite number of points around the aircraft the test team needs to carefully select the flight test profiles to ensure that data are collected at the required frequencies, aspects, and ranges.

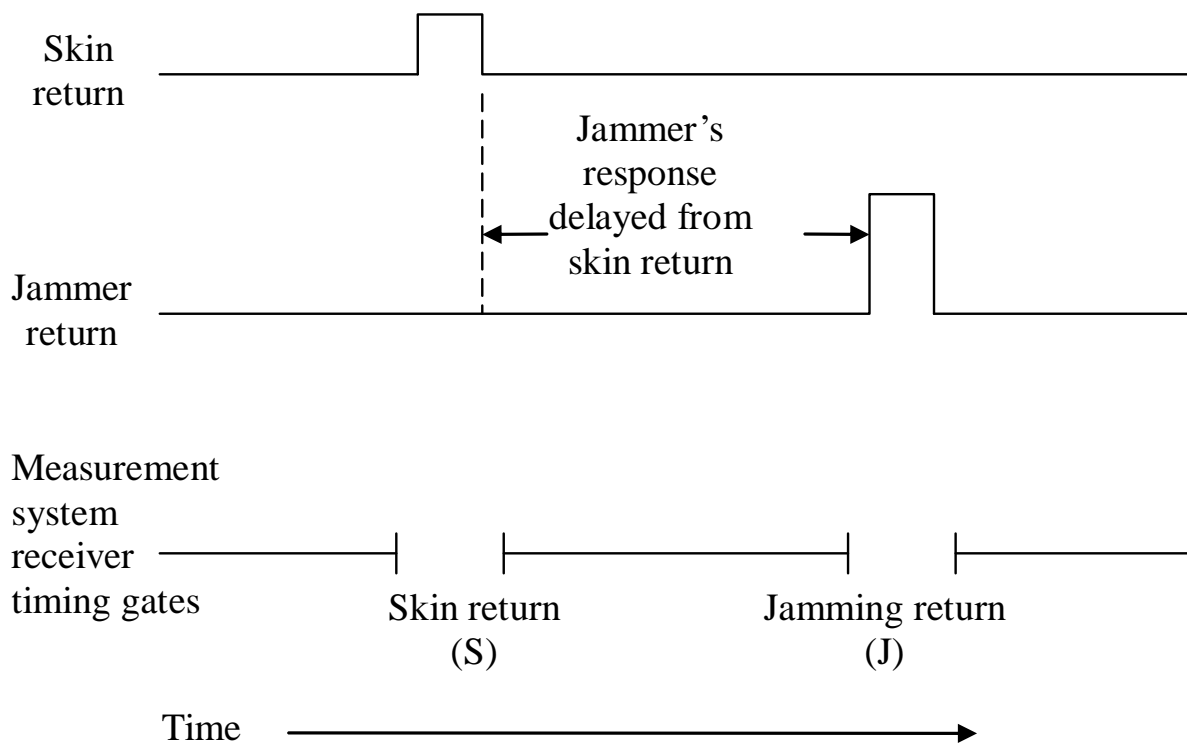

Figure 3-6: Example J/S Measurement Technique.

There are a number of limitations associated with flight testing on an OAR. As is the case with RWRs, only a small number of threat simulator systems exist on an OAR. If a required threat system isn't available on an OAR, the best level of fidelity that can be achieved is using a HITL facility. The background environment is limited and thus restricts the pulse densities that can be achieved to evaluate the SPJ performance at required high-pulse densities.

EMC testing on some airborne SPJ systems can only be accomplished in flight. This type of testing may or may not require OAR ground-based radar participation. If the test aircraft has sufficient onboard ability to stimulate and control the SPJ system to achieve the desired test conditions, OAR support may not be necessary.



### **3.2.3.3 Additional SPJ T&E Considerations**

Many decision makers want to quantify the contribution that an SPJ makes to aircraft survivability and ultimately mission accomplishment. It is difficult to isolate the jammer's contribution because there are a number of interrelated complementary factors that affect survivability and the jammer's effect is only one of these.

Another consideration working against the direct applicability of DT&E flight test results to operational effectiveness assessments is that operational aircrews do everything possible to minimise their exposure to hostile air defences. An aircraft when detected and engaged by a hostile air defence system will, to the extent possible, practice threat avoidance, e.g., terrain masking, employ other countermeasures such as chaff, and employ tactical manoeuvres in concert with the active jamming. If DT&E were conducted according to this philosophy, the test team might not get much data and the data collected would confound the jammer effects with other factors.

A developmental tester wants to collect as much relevant data as possible about the SUT. Due to the cost of OAR time and scheduling difficulties, this often drives the use of non-operationally representative test profiles (ones that maximise the exposure to the threat systems to make the best use of valuable range time) that isolate jammer performance so that it can be segregated from other factors. It is important to remember that even though this type of testing isolates the jammer performance, it does not necessarily translate into quantifying the jammer performance for operational effectiveness assessments.

In most cases the DT&E test conditions are conducted using straight and level flight conditions. This is done to focus the analysis on whether or not the jammer is performing properly. This is obviously not an operationally representative condition and the results are difficult if not impossible to extrapolate to draw quantifiable tactically relevant conclusions about the jammer's contribution to survivability. While operationally representative test conditions are generally not central to DT&E evaluations, they should be kept in mind.

No single MOP encapsulates the worth of a RFCM system. Even taken in aggregate it is difficult to make value judgments. Some MOPs such as those addressing track errors (azimuth, elevation, range and/or velocity), are quantifiable. However, while they provide good measures for evaluating radar performance, they don't directly relate to the ability of the weapons system to successfully engage a target. Other measures that focus on the success of the weapons engagement, such as miss distance, rely on fly-out simulations and their associated assumptions. Additionally, miss distance by itself doesn't directly address the success or failure of the weapon engagement; most RF missile warheads are proximity fused and the engagement geometry, fusing, and warhead characteristics significantly affect the engagement outcome. While missile miss distance produces a quantifiable result, a number of measures require the analyst to make a hit/miss determination and this involves a number of subjective judgments.

Analysts need to have a thorough understanding of how threat-radar systems work and operate in order to evaluate test results. As previously stated it is difficult to quantify a jammer's contribution to overall platform survivability. However, by evaluating a number of MOPs in aggregate, the analysts need to determine if the RFCM system is having the intended effect on each victim radar and whether or not the effect will be significant (even if it can't be quantified in terms of overall survivability).

## **3.3 SUPPORT JAMMERS**

Support jammers perform offensive EA. They share many similarities in design and functionality with SPJ, but unlike the SPJ, a support jammer is primarily designed to protect other aircraft from the surveillance radars of hostile air defence systems while they conduct their missions. [1]



### 3.3.1 Support Jammer System Concepts and Operation

Support jammers perform three basic roles:

- **Stand-Off Jamming (SOJ)** – Normally performed by a manned aircraft operating outside the engagement range of hostile air defence systems;
- **Escort** – Normally performed by a manned aircraft accompanying a strike package; and
- **Stand-In Jamming** – Normally performed by unmanned expendable air vehicles operating within the engagement range of hostile air defence systems.

Figure 3-7 illustrates these roles.

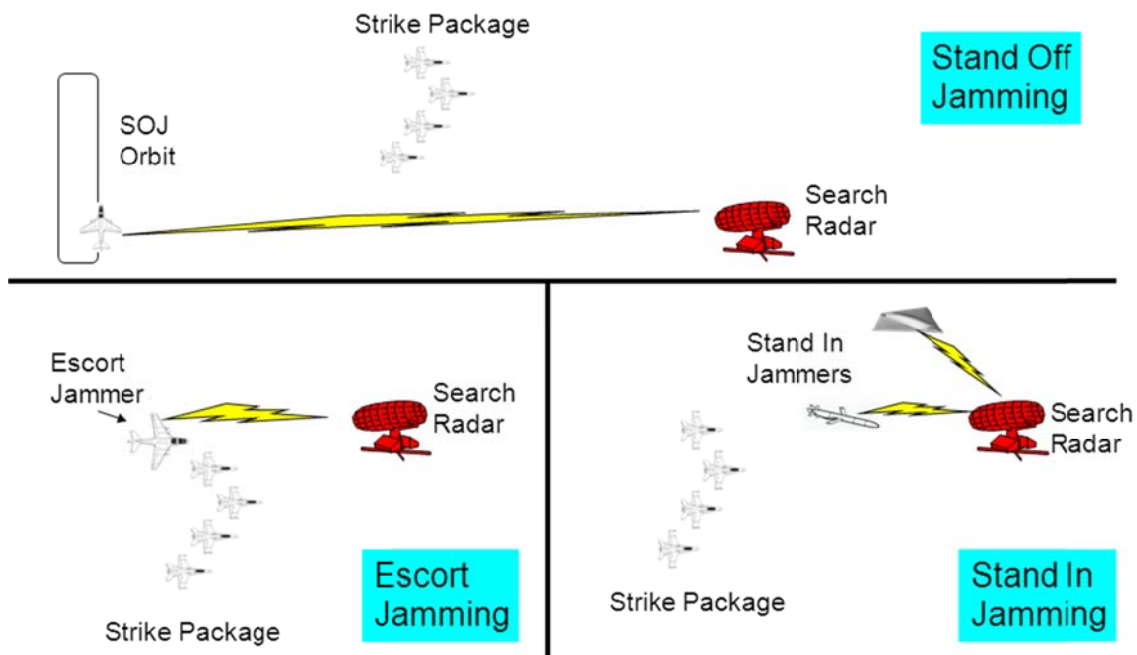

Figure 3-7: Different Types of Support Jamming.

Support jammers have the same functional elements as described in Section 3.2.2 and shown in Figure 3-3. These systems can be carried internally or externally on a manned aircraft. Commonly the receiver systems are internally mounted and the transmitters are carried in external pods as shown in Figure 3-8. Stand-in jammers are normally expendable and launched from a host platform. Figure 3-8 shows a Miniature Air-Launched Decoy (MALD). A special MALD variant, the MALD-J, performs stand-in jamming.



**Figure 3-8: a) EA-6B Aircraft with External Jamming Pods; b) Miniature Air Launched Decoy Carried by F-16 – (U.S. DoD Photos).**

Support jammers conduct EA operations primarily to deny, degrade, or delay the detection of friendly aircraft by the surveillance radars of an IADS. As with SPJ systems, it is important to understand the basic operation of the radar systems that the jammer attacks. Surveillance radars commonly scan a volume of airspace covering 360 degrees in azimuth, although some cover more limited sectors.

Surveillance radars report detected targets up echelon to the command and control elements of an IADS to aid in forming the air picture in one of two ways: an operator watching a radar scope manually identifies targets or a computer called a target extractor automatically identifies targets. Noise jamming is designed to raise the noise level in the victim radar’s receiver thereby reducing the signal-to-noise ratio and decreasing the probability of target detection. False target jamming is designed to present the operator or the target extractor with a large number of false targets that cannot be discriminated from the real targets. Figure 3-9 shows the effects of noise and false target jamming on a Plan Position Indicator (PPI) displays.

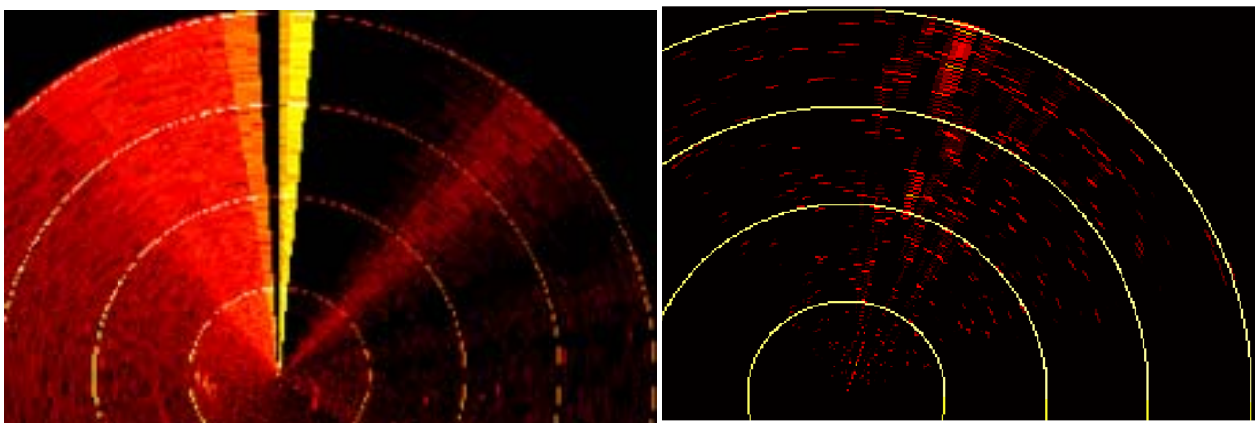

**Figure 3-9: Effects of Noise and False Target Jamming on PPI Displays.**

### 3.3.2 Support Jammer System Testing

Support jammer testing is in many ways similar to SPJ testing and most of the discussion in Section 3.2.3 applies. The following paragraphs address the areas that are unique to support jammer testing.

J/S ratio is also a critical measure for support jammers, but it is manifested differently. In the SPJ case, the main beam of the threat system TR radar is centred on the target it is tracking, allowing the SPJ to continuously direct most of its jamming energy into the victim radar’s antenna main lobe. This maximises

the jamming energy transfer by virtue of the geometry. In contrast, the support jammer normally operates against scanning radars antenna side lobes and can only jam into the victim radar antenna's main lobe when it is aligned with the jamming platform. Annex C develops the J/S expression for the support jamming case.

Jamming performance assessments against search radars are different for noise and deceptive techniques. This is because they are fundamentally attacking two different things. Ideally, a noise jammer raises the noise level in the victim receiver to the point that targets cannot be detected. In the ideal deceptive jamming case the victim receiver is presented with an overwhelming number of realistic false targets where the true targets cannot be discriminated.

Flight testing against high fidelity simulators or actual threat radar systems provides the highest level of fidelity when evaluating the jamming effects on an individual surveillance radar system. This environment provides actual radar clutter, multi-path effects, and operator displays.

Support jamming effectiveness against manned systems can vary significantly with operator skill level. One operator may be able to see targets in a high-level noise jamming environment while another may not. Similarly, some operators may be able to tell the difference between real and false targets while others may not.

ROE defining what EP features the radar operators will be able to use need to be clearly defined. The ROE relate to the specific objective that the test address.

### **3.4 RF TOWED DECOY SYSTEMS**

Radio frequency towed decoys are defensive EA systems performing self-protection jamming. They differ from onboard SPJ in that they are countermeasures systems dispensed from the host aircraft either pre-emptively or automatically in response to a hostile radar threat engagement. They are towed behind the aircraft and designed to present a more seductive target to the hostile radar or missile seeker. Most towed decoys are expendable, although retractable models exist.

#### **3.4.1 Towed Decoy System Concepts and Operation**

A towed decoy has one significant advantage over onboard SPJ system. It is difficult for onboard SPJ systems to create angle tracking errors against monopulse radars. In the towed decoy case, if the radar or missile seeker is tracking the towed decoy, it is not tracking the targeted aircraft and there is an inherent angle tracking error.

There are two basic types of towed decoys. The first is a simple repeater that retransmits the targeting radar waveform at a higher signal level in order to seduce the track away from the target aircraft; it is essentially a beacon. Figure 3-10 shows a block diagram of a simple repeater. Once deployed the system only requires power and control from the host platform. When the system receives an RF signal via the towed decoy onboard receiver that meets the threat criteria, it amplifies and retransmits the signal in hopes of seducing the threat track.

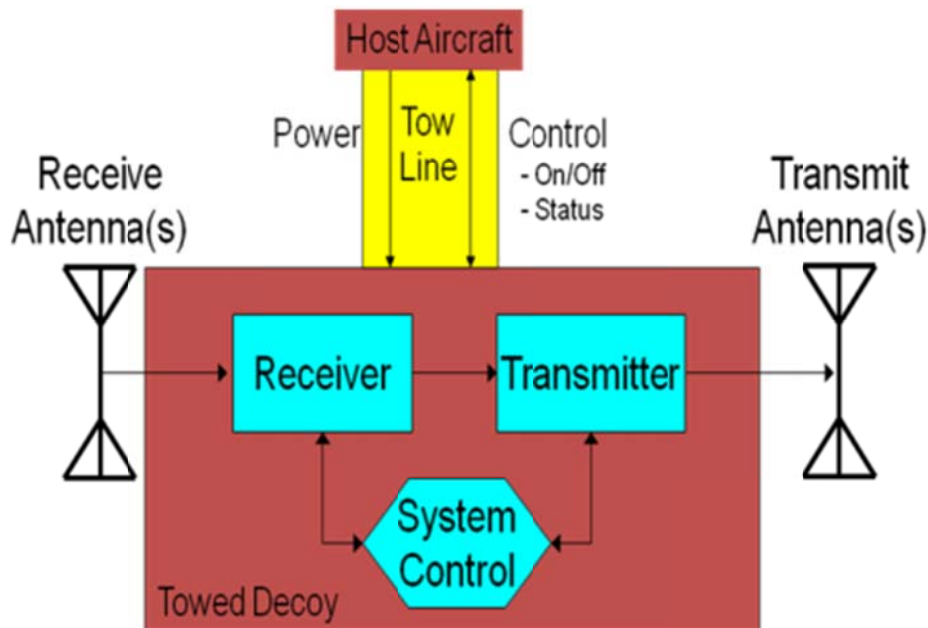

Figure 3-10: Simple Repeater Towed Decoy Block Diagram.

The second type are Fibre-Optic Towed Decoys (FOTDs). FOTDs employ sophisticated receivers and technique generators onboard the host aircraft. Figure 3-11 shows a block diagram of an FOTD system. The receiver systems associated with FOTDs are very similar to EW receivers discussed in Chapter 2. The onboard receiver passes threat information to the technique generator in a manner similar to the SPJ operation. It differs from the SPJ case in that it converts the RF technique to optical wavelengths and transmits it via fibre-optic cable to the FOTD where it is converted back to RF, amplified, and retransmitted.

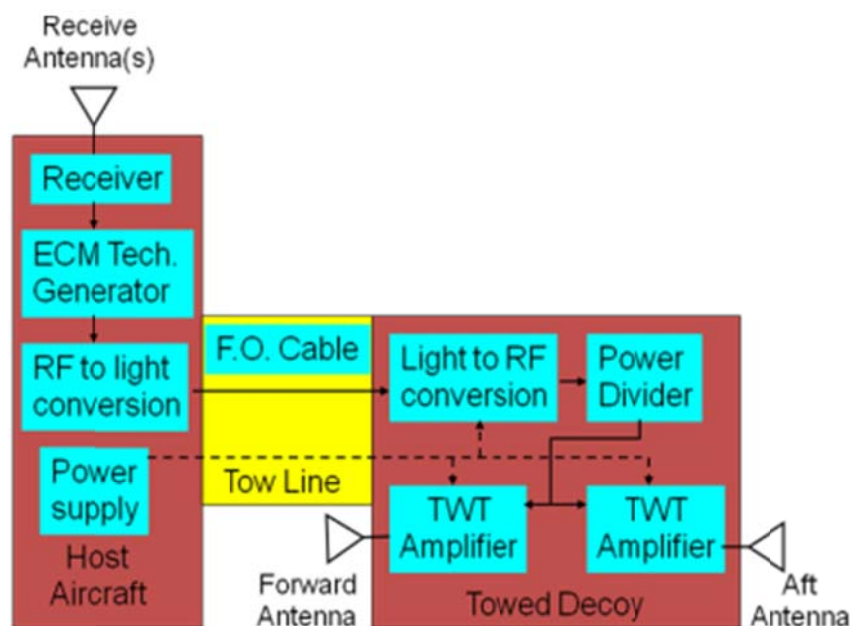

Figure 3-11: Fibre Optic Towed Decoy Block Diagram.

Both decoy types typically use Travelling Wave Tube Amplifiers (TWTAs), although Microwave Power Module (MPM) technology is now also used. Figure 3-12 shows a typical towed decoy.

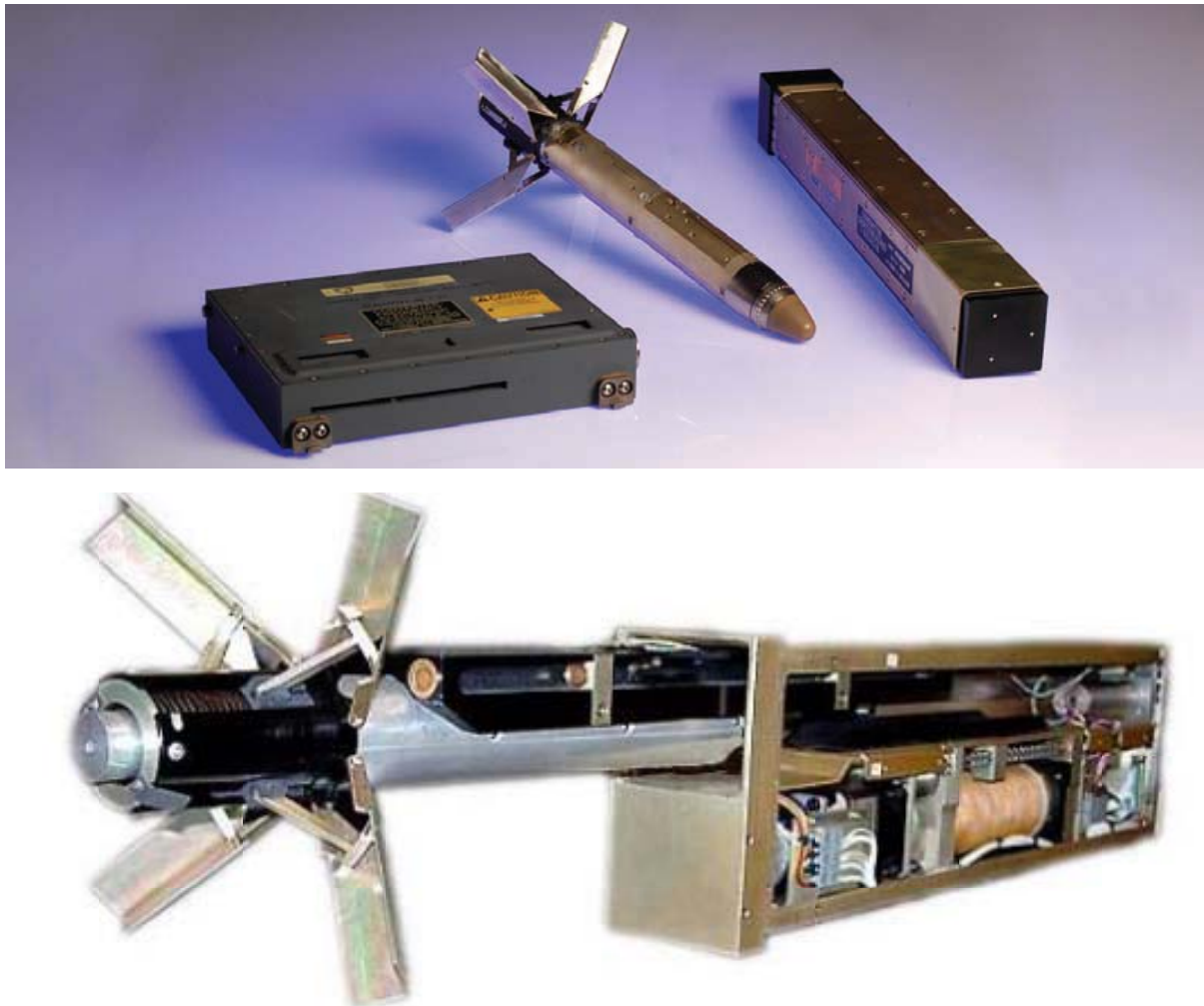

Figure 3-12: Typical Fibre Optic Towed RF Decoy – AN/ALE-55 – (BAE SYSTEMS Photo).

### 3.4.2 RF Towed Decoy Testing

All of the discussions in the EW RF receivers test section apply to towed decoys and the technique generation testing is similar to the SPJ testing. The major difference is that the decoy must properly deploy in a timely manner. Decoy deployment is a complicated process, as is retraction, for those systems with that capability.

#### 3.4.2.1 Uninstalled Towed Decoy Component Testing

All of the concepts associated with testing RF receivers, signal processing, and technique generation also apply to towed decoy development and testing. M&S can be used to evaluate the aerodynamic separation characteristics as well as the performance and effectiveness of the towed decoy system.

One of the most challenging aspects of towed decoy development is the mechanical deployment (and possibly retraction) of the device. Flying test beds provide the system developers an opportunity to collect data under a variety of flight conditions.



### **3.4.2.2 Installed Towed Decoy Testing and Performance Assessments**

Towed decoy deployment from a flying test bed provides an excellent opportunity to develop the system and reduce risk. However, the flying test bed is likely to have a significantly different aerodynamic and vibro-acoustic environment and towed decoy separation characteristics than the production airframe. The decoy needs to cleanly separate or it may damage the host aircraft and/or the decoy. Decoy deployment testing should be conducted throughout its required operating envelope to determine any deployment or towing limitations.

Fully functional towed decoy rounds are expensive and are generally not required to evaluate separation and deployment characteristics. Towed decoy mass models have the same weight and balance and aerodynamic characteristics as an actual round without any of the expensive electrical components.

Towed decoy deployments happen rapidly and high speed cameras installed at one or more locations on the host aircraft can document the towed decoy separation from the aircraft. Safety and photo chase are also very useful in case there is a deployment mishap.

Reactive towed decoy systems need to deploy the decoy to its full deployment length in a very short time and operate properly when it gets there. The mechanical braking system and associated algorithms must be evaluated to ensure they work properly. If too much braking force is applied, the decoy will take too long to deploy. If too little braking force is applied near the end of the deployment, the sudden stop may subject the towline to a load that will cause the towline to fail and the decoy to break away. A properly instrumented decoy system will greatly aid in deficiency investigations.

Towed decoy systems present several test safety considerations. The towed decoy rounds typically use pyrotechnic charges to initiate the decoy deployment and to sever the round when it is no longer needed or if it has malfunctioned. An armed towed decoy round is a munition and need to be treated with all the appropriate safety precautions.

Towed decoys can inadvertently separate from the host aircraft and present a risk to personnel on the ground. Developmental towed decoy operations should take place over controlled ground ranges to ensure personnel and high-value material will not be put at risk if a decoy malfunction causes an unplanned separation.

## **3.5 ACTIVE INFRARED COUNTERMEASURES SYSTEMS**

Conventional active IRCM systems are electrically powered defensive EA systems designed to protect aircraft from IR-guided missiles. There are several types of IRCM systems. The simplest is a 'turn on and forget' system that uses a modulated IR jamming waveform that transmits continuously over its field of view. Figure 3-13 shows a typical undirected IRCM system installation.



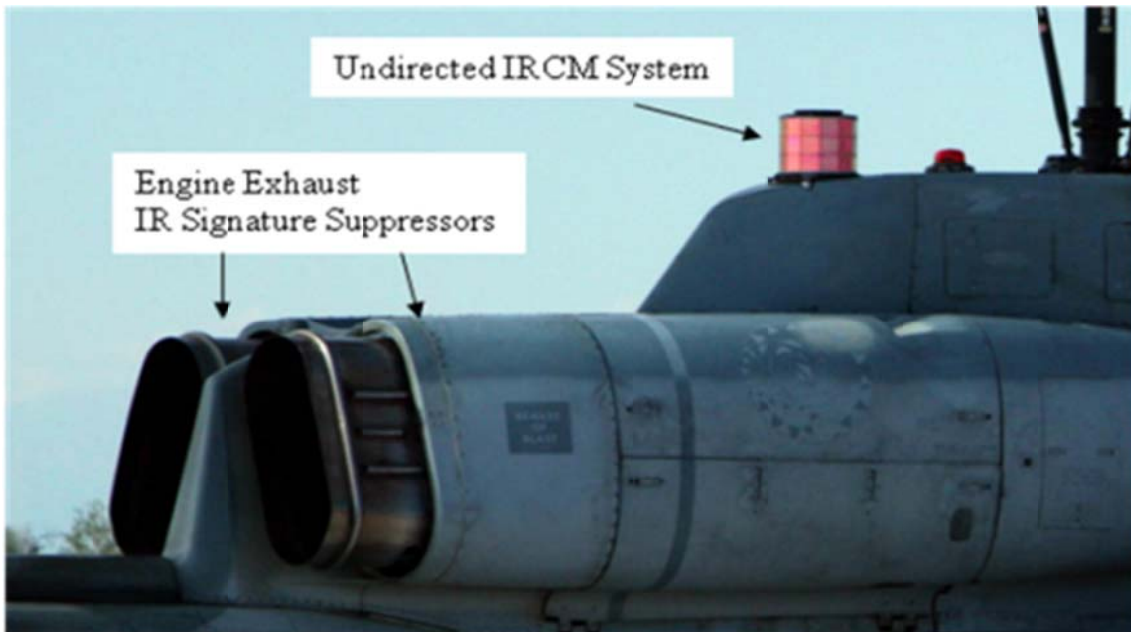

Figure 3-13: AH-1 IRCM Installation and IR Signature Suppressors – (U.S. DoD Photo).

More sophisticated IRCM systems, often called Directed IRCM (DIRCM) systems, are turret mounted and receive cuing information from MWS. These systems typically use either arc-lamp or laser-generated AM jamming waveforms. Laser-based systems have the advantage of directing significantly more energy into the victim missile seeker. Figure 3-14 shows a typical DIRCM installation.



Figure 3-14: Department of the Navy Large Aircraft Infrared Countermeasures Installation on a CH-53E Helicopter – (U.S. Naval Air System Command Photo).

DIRCM systems typically receive cuing from an MWS and slew a turret assembly (an aircraft may employ several turrets to achieve the required spatial coverage) toward the threat missile. Each turret has a fine-track sensor that will then take over tracking (as with the MWS, the fine-track sensor also tracks the missile plume) the inbound missile and direct the countermeasure transmitter or laser toward the missile seeker. The DIRCM transmitter or laser is boresighted to the fine-track sensor, such that the jamming energy is directed along the line of sight of the fine-track sensor toward the missile seeker. Figure 3-15 shows a typical DIRCM engagement sequence.

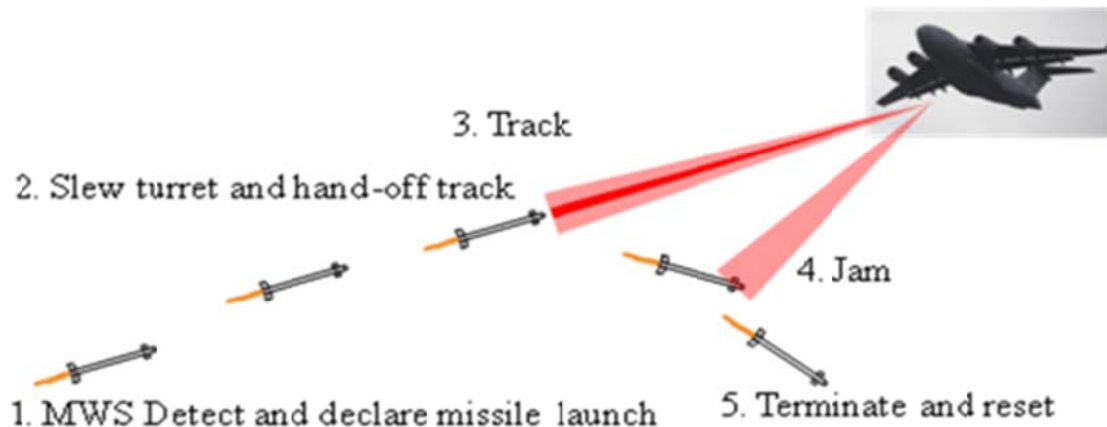

**Figure 3-15: DIRCM Event Sequence.**

IRCM performance can be enhanced by reducing the IR signature of the target aircraft. This can be accomplished by a variety of means, including installing engine exhaust suppressors as shown in Figure 3-13 or by using low-IR-signature paint on the aircraft fuselage. To further enhance IRCM performance, flare expendables are often used with IR jammers.

### **3.5.1 Active IRCM System Components and Operation**

The following sections address the components of a typical active IRCM system. The MWS portion of DIRCM systems is addressed in Section 2.3.

#### **3.5.1.1 Countermeasures Codes**

The ‘processor’ of an IRCM system is a modulated power supply that drives the transmitter. Through threat analysis or exploitation, the scanning frequencies of the missile-tracking circuits are determined and these frequencies are programmed into circuitry used to modulate the power supply. The modulated power supply is either present as standalone hardware in the cargo bay area or integrated in the transmitter. In both cases, manual switches are present to allow selection of pre-programmed jam codes. Additional IRCM codes can be pre-programmed as new threats are defined.

#### **3.5.1.2 Controls and Displays**

The pilot interface is through a control indicator located in the cockpit. The pilot control indicator is either a standalone module for the IRCM system or it is shared with another EW system. The interface is usually quite simple, only providing a means of turning the system on or off and a way to alert the pilot that a malfunction has occurred.

### 3.5.1.3 Transmitter

There are several methods to generate the required IRCM pulses. One technology uses heated carbon-material rods and mechanical modulation techniques to generate the pulsed IR radiation to deceive the incoming missile seeker. Another technology uses an arc lamp in a vacuum tube, which is electronically modulated to provide the required pulsed IRCM radiation. Lasers are becoming the IRCM transmitter of choice due to their ability to inject high energy jamming into the missile seeker.

The basic undirected IR transmitters usually have a wide field of view (180 to 360 degrees in azimuth) and are typically located as close to the engine exhaust as possible since most of the IR threat missile seekers tend to initially acquire and lock onto this 'hot spot.'

DIRCM systems employing arc lamps and lasers focus their energy toward the homing missile seeker. The laser systems employing coherent energy have very small beam divergence and can direct significant energy into the victim seeker. The arc lamp will spread its energy over a wider field of view resulting in lower energy levels incident on the victim seeker detector.

## 3.5.2 IRCM System Testing

As with RFCM systems, the chief concern for IRCM systems is the degree to which they enhance the survivability of the host platform. Similarly, missile miss distance is a key consideration in evaluating the effectiveness of the IRCM system. There are several factors making the IR case somewhat easier to evaluate. First, once launched, IR missiles do not have an operator in the loop. Unlike the RFCM system, the IRCM system is an open-loop system; it does not get feedback from the system it is jamming (the missile seeker is a closed-loop tracker and the focus of the evaluation). Also, live-fire events are somewhat less costly and more practical.

A major figure of merit for IR jammer effectiveness is the J/S ratio that the system can achieve. Specifically, the higher the amount of modulated radiation output (provided by the jammer) over the host aircraft signature, the better the IRCM performance will be in countering the threat of the same IR spectral bandpass.

An end-to-end flight test of an integrated MWS and DIRCM system would require live-fire missile launches at a drone aircraft carrying these systems. While this is feasible and potentially desirable, there are other ways to evaluate the performance of these systems. Testing can be broken down into two parts: the missile launch detection and hand-off information accuracy (see Section 2.3.2), and the IRCM effectiveness. These two pieces can be tested and evaluated independently. The first evaluation addresses whether or not the MWS can quickly and accurately detect and hand off the engagement to the fine-track sensor. Once the fine-track sensor has acquired the missile, the IRCM will be directed in an open-loop fashion at the missile seeker.

### 3.5.2.1 Uninstalled IRCM System Component and System Level Testing

The jammer spectral and temporal signatures can be measured with great precision and accuracy in a laboratory and the host aircraft signature can be measured in flight. In-flight signature measurement with ground-based or airborne radiometers requires accurate range to the target and angle information and meteorological conditions (barometric pressure, ambient temperature, and relative humidity) to account for atmospheric transmissivity. The J/S of the host aircraft can be calculated when the jammer characteristics and the aircraft signature are known.

HITL facilities provide an excellent venue to develop and evaluate IRCM techniques. These facilities allow evaluation of the effects of the actual IRCM transmitter, such as a laser, on actual seeker hardware. A highly instrumented seeker installed on a full-motion flight table, such as shown in Figure 3-16,

supporting a high-fidelity missile fly-out model, tracks a dynamic simulated target in an IR scene. The laser countermeasures are injected into the scene through a series of folded optics. This presents a realistic target scene with both the simulated target IR signature and the IRCM energy concurrently being presented to the missile seeker. This allows a wide variety of conditions to be evaluated in a short time.

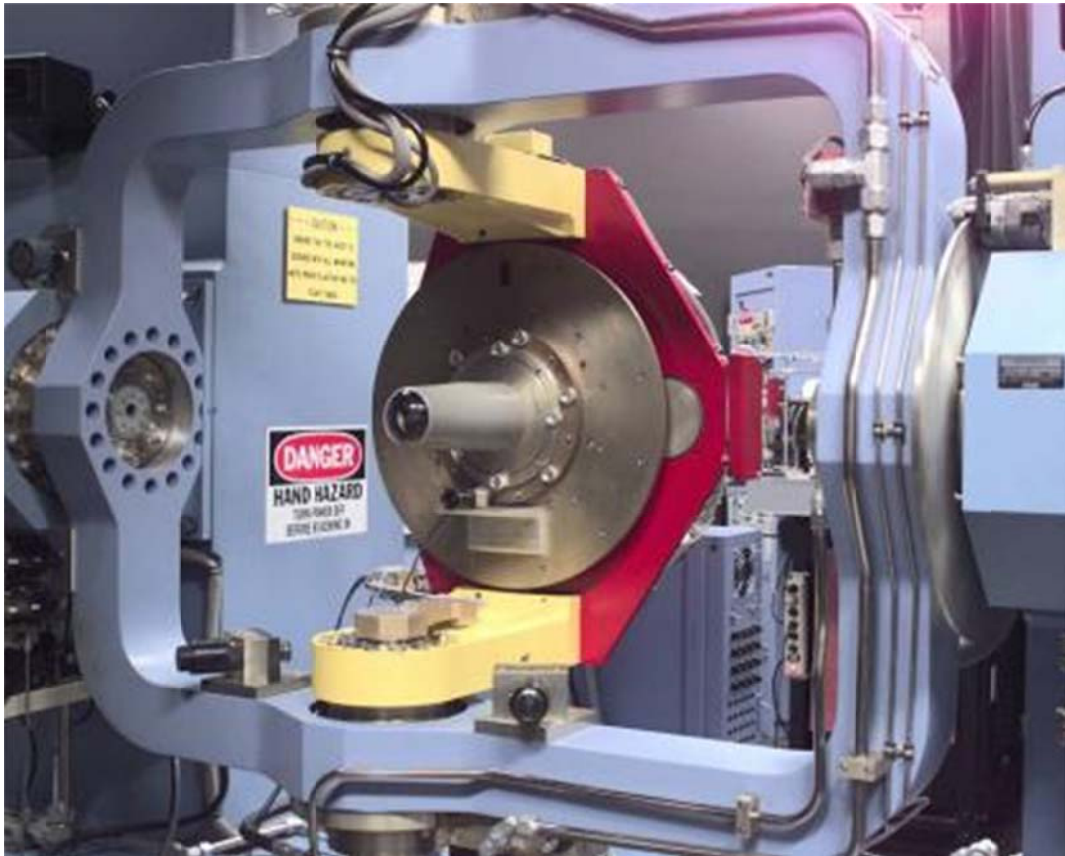

**Figure 3-16: IR-Guided Missile Seeker Mounted on Full Motion Simulator – (U.S. DoD Photo).**

An end-to-end system test can be accomplished using the cable car testing addressed in Chapter 2. In this case the instrumented MWS is integrated with the instrumented IRCM system and a live missile launch is directed at the cable car. The MWS can be evaluated on its ability to detect the launch and hand off the track and the IRCM system can be evaluated on its ability to acquire the missile and counter it.

One of the most complete and correspondingly expensive means of evaluating IRCM performance is live-fire testing. Live-fire evaluations can be conducted by installing an instrumented (preferably with telemetry capability) IRCM system, or IRCM and MWS system in the integrated case, on a drone aircraft and a true end-to-end engagement can be considered. The cost of certain IR-guided missiles is relatively low and this can be a cost-effective means of testing the IRCM system. However, the cost effectiveness of the test is directly related to how well the IRCM system performs. The cost planning needs to account for the possibility that the IRCM system is ineffective or malfunctions, resulting in the loss of drone and SUT.

### 3.5.2.2 Installed IRCM System Testing

There are several common methods of evaluating IRCM system performance in flight test. Each has advantages and disadvantages. Much of the DIRCIM installed system testing is done in flight, providing an



end-to-end evaluation incorporating the actual target aircraft signature. End-to-end testing requires three things, the ability to:

- Simulate a valid missile launch and generate an MWS missile launch declaration;
- Determine if the IRCM has been properly directed; and
- Assess the effectiveness of the IRCM on actual missile seekers.

Ideally, the test aircraft will be instrumented to record the MWS missile detection and declaration data as well as the hand-off and IRCM turret pointing data. The JMITS shown in Figure 2-17 and Figure 3-17 incorporates all of the elements necessary to perform end to end testing. Figure 2-17 shows the high fidelity JMITS IR/UV missile plume simulators and Figure 3-17 shows the JMITS laser radiometers used to detect the IRCM response and the instrumented missile seekers. The capability to record the IR signature of the test aircraft with ground-based radiometers is also desirable.



Figure 3-17: Joint Mobile IRCM Test System – (U.S. DoD Photo).

Static, ground-mounted, seeker-based test systems have the advantage of using actual instrumented seeker hardware tracking the host aircraft against which the IRCM performance can be evaluated. There are, however, several disadvantages that need to be considered during test design. First, the test aircraft flight profile must be designed to ensure that MWS doesn't reject the launch simulation based on engagement kinematics. Second, static missile seekers do not have realistic motion associated with an actual missile fly-out. Specifically, the missile isn't closing on the target at a realistic rate and doesn't have to react to the high angular rates of change associated with a real engagement, particularly at endgame.

### 3.6 COUNTERMEASURES DISPENSING SYSTEMS

CMDS are most commonly employed in a defensive electronic attack role. They dispense expendable payloads to deceive hostile air defence weapons systems. Conventional chaff and flares are the most common payloads and some CMDS are also capable of ejecting expendable (non-towed) RF decoys.

Chaff is one of the oldest forms of radar electronic countermeasures. It consists of a large number of micro-fibre reflective dipoles. When dispensed it disperses in the air stream forming a cloud and presenting the hostile radar with other competing large RCS targets. Figure 3-18 shows a typical round assembly and chaff fibres.



**Figure 3-18: Typical Chaff Rounds and Chaff Dipoles – (U.S. Navy Photo).**

Flares are pyrotechnic devices designed to deceive IR-guided missiles by presenting the missile seeker with a more attractive target than that the target aircraft. Conventional flares are made of various combinations of magnesium, phosphorus, and Teflon which is ignited when the flare is dispensed from the magazine and tries to mimic relevant spectral aircraft engine characteristics. Figure 3-19 shows F-16 and AC-130U aircraft dispensing conventional flares.





**Figure 3-19: Flare Dispensing by F-16 and AC-130U Aircraft – (U.S. DoD Photos).**

Flare technology continues to adapt to keep up with the advancing threat. Conventional flares are highly visible in the visual portion of the electromagnetic spectrum and can give away the position of an aircraft, particularly at night. To alleviate this problem, flares with minimal visual signature have been developed that still retain the required IR signature characteristics. Kinematic flares have also been developed to overcome the kinematic EP logic in some modern threat missile seekers. These essentially fly along with the aircraft as they separate and have a less abrupt angular separation from the host aircraft.

### 3.6.1 CMDS Components and Operation

CMDS are commonly installed in an integrated configuration and receive threat-related information from RWR and MWS to optimise dispense patterns and enable automatic operation. Most have three modes:

- **Manual** – Aircrew-initiated programmed response;
- **Semi-Automatic** – Automatically generated response requiring aircrew prior consent; and
- **Automatic** – Autonomous operation, i.e., without aircrew input.

A typical CMDS comprises a Cockpit Control Unit (CCU), a programmer, sequencers, the dispenser and magazine, and a safety switch. Figure 3-20 depicts these components and their functions.

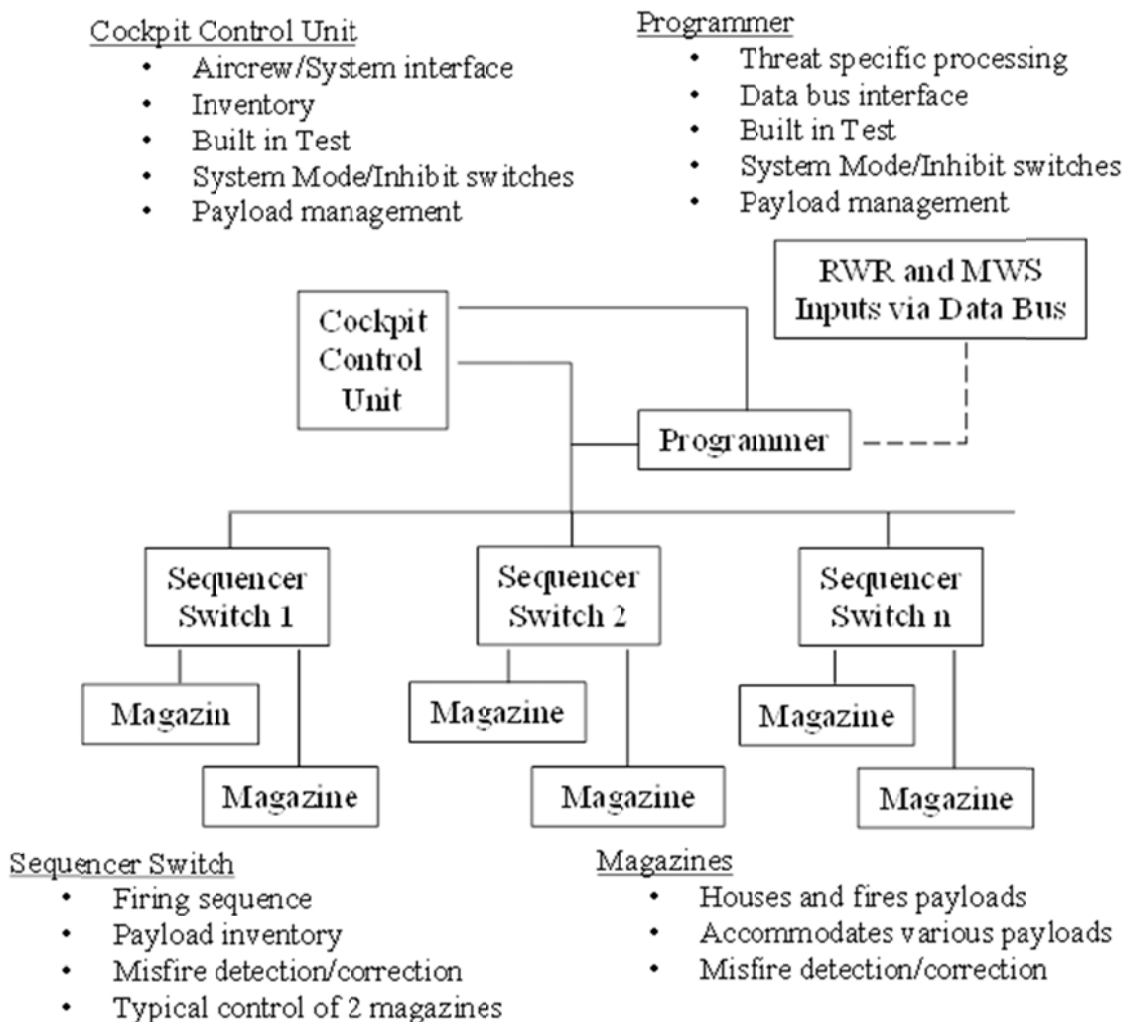

Figure 3-20: Block Diagram of Countermeasures Dispensing System.

Figure 3-21 indicates these components in a typical CMDS.



Figure 3-21: Typical CMDS – AN/ALE-47 – (Symetrics Industries Photo).

### 3.6.1.1 Control Unit

The CCU is the aircrew interface with the CMDS. It allows the operator to select the system mode, determine the remaining inventory, and programme the manual dispense parameters. The manual dispense parameters include the number of rounds in a burst and the time intervals between bursts. Other functions accessible through the CCU include the built-in-test and jettison. In many systems these features can be integrated with the avionics system and can be accessed via a glass cockpit.

### 3.6.1.2 Programmer

The programmer is the CMDS processor where both OFP and MDF reside. It typically receives threat data inputs via a data bus from the MWS and the RWR. The RWR typically provides threat specific data that along with aircraft airspeed and attitude data are used to optimise the response. The threat data consist of the parametric data that define the threat system. Pulse width, RF frequency range, amplitude or scan modulation, and pulse-repetition frequency are typical RF-threat parameters. Response data involve the specific dispensing technique against a known or identified threat. Responses consist of IR expendables, RF expendables (chaff), or a combination.

Dispense techniques are defined by the quantity and intervals at which the expendables are deployed. Payload data identify the types of expendables loaded into the dispenser and are available to be dispensed. During flight, the system monitors the magazine to keep track of how many and what type of expendables remain.

### 3.6.1.3 Sequencer

Sequencers distribute power and commands to dispensers. They manage payload inventories and determine if a misfire has occurred. Typically, one sequencer is used for every two dispensers.

### 3.6.1.4 Dispenser

The dispensers are housings for the magazines and are installed in the aircraft at the location where the expendables are to be released. The magazines are the modules that actually hold the expendables. Dependent upon expendable origin, preparation may be required prior to insertion into magazines:

- The US normally procures squibs (the pyrotechnic firing mechanisms) and flares separately, and these are not combined until shortly before use. They are inserted into the magazine, one squib for each expendable, prior to inserting each expendable.
- European manufacturers generally supply expendables with squibs ready fitted.

Squibs can only be used once and must be replaced like the expendables. Expendables are then loaded into the magazines in a safe area and then an entire magazine is inserted into a dispenser housing before each flight. Typical magazines on tactical aircraft hold approximately 30 expendables each. Figure 3-22 shows a typical CMDS dispenser with magazines installed.



**Figure 3-22: CMDS with Magazines Installed on a C-130 – (U.S. DoD Photo).**

The safety switch is an important part of the CMDS. When engaged, it does not allow any current to reach the dispenser, thus eliminating the chance of a squib accidentally firing.

### 3.6.1.5 Expendables

Expendables payloads are generally not produced by the CMDS manufacturer. All CMDS support conventional chaff and flare rounds. Many support other advanced payloads such as kinematic flares. Chaff,

flare, and other advanced expendable rounds, including RFCM, are continuing to evolve and the CMDS must be able to accommodate them. The expendable payload manufacturers design their products to be compatible with existing dispensers. CMDS OFP and MDF changes may be required to accommodate new expendable products. Figure 3-23 indicates typical flare and chaff cartridge used across NATO. [2]



**Flare Cartridges: 36 mm, 2 x 2.5, 2 x 1, 1 x 1; and their associated impulse cartridges**



**Chaff Cartridges: 36 mm, 1 x 1 (dual), 1 x 1 (Standard) and their associated impulse cartridges**

**Figure 3-23: Examples of Expendable Configurations Within NATO (From [2]).**



### **3.6.2 CMDS Testing**

CMDS and airframe designers and developers extensively employ M&S to explore the critical question of where the CMDS dispenser should be installed on the host airframe. This is a particularly important consideration for flare dispensers. High fidelity aircraft structure and signature models allow designers to evaluate a variety of potential installations and their associated payload trajectories against the models of the threats of interest under a variety of engagement geometries.

Much of the CMDS and payload development testing can be conducted independently and concurrently for new systems. However, the CMDS and payload combined performance and effectiveness can only be evaluated in flight with the CMDS installed on the intended host platform using the intended payloads. This allows the payload effects to be evaluated with actual aerodynamic and host aircraft signature characteristics.

#### **3.6.2.1 Uninstalled CMDS Testing**

##### *3.6.2.1.1 CMDS Component Testing*

Hardware laboratory testing includes verifying that each separate CMDS module functions properly and operates within design parameters. Power, continuity, voltage, and Built-In Tests (BITs) are performed. These tests help to isolate hardware configuration or interface problems.

Software laboratory tests are performed on each module containing software. These tests help isolate any programming or timing errors and verify that the system software has been correctly implemented. Such errors can impact not only system performance, but may affect safety and survivability. Manual and automatic dispense capabilities are also evaluated to verify performance.

##### *3.6.2.1.2 CMDS Level Testing*

When the performance of the individual components has been verified, the CMDS can be tested as a complete system. Unlike many other EA systems the CDMS system does not have associated sensors. However, it does communicate via data buses with sensor systems such as RWR and MWS. Emulated data bus messages are generally sufficient to evaluate system level performance and laboratory RF threat simulation is generally not required for initial system level testing.

System level CMDS testing also verifies the proper operation of all operator switch settings. All system modes of operation can be tested in conjunction with a wide range of emulated RWR and MWS data bus messages. The dispenser assemblies are monitored to ensure that the proper firing pulses are generated in response to the test conditions.

Integration testing is the next stage of testing. It is conducted with the complete CMDS installed in a laboratory environment connected to actual avionics and EW hardware with representative aircraft cabling. This type of testing allows end-to-end system integrated system evaluations where the RWR is injected with simulated RF threat signals and/or the MWS sensors are stimulated. The data bus message traffic and the CMDS responses are monitored and recorded to verify proper operation.

Cable car testing is an effective means to evaluate end-to-end system level flare performance against actual missiles. The MWS and CMDS are integrated and installed on a cable car, see Figure 3-24. The number of flares dispensed and the timing between them is critical. This type of testing allows analysts to optimise system performance by evaluating the effects of number of bursts and timing intervals.





**Figure 3-24: Flare Testing Using a Cable Car – (U.S. DoD Photo).**

#### *3.6.2.1.3 Expendable Payload Testing*

Expendables are tested to verify that they meet their design specifications and requirements. Key IR expendable parameters include time to ignite, total burn time, spectral signature content, and intensity. RF expendables are tested to measure RCS “bloom” rate, which is how fast the expendable can achieve the desired RCS, fall rate, and actual frequency range over which the RCS can be achieved.

A single type of expendable payload will likely be employed on a variety of host aircraft and each dispenser installation will have unique separation characteristics. Additionally, many platforms employ a variety of expendable payloads. Software modelling should be performed to predict the separation characteristics for each type of expendable round that will be employed.

### **3.6.2.2 Installed CMDS Testing**

#### *3.6.2.2.1 Ground Testing*

During installed-system test facility testing, dispenser systems are installed on a production representative aircraft and all functional tests are repeated to verify the system operates properly. These tests are conducted to verify electrical, mechanical, software, and EMC/EMI functionality and performance.

When EMI/EMC testing is conducted in an anechoic chamber where munitions cannot be used CMDS maintenance test sets can often provide a suitable means of monitoring the CMDS dispenser firing commands. It is critical to verify that the system will not inadvertently dispense its payload when operating in the presence of onboard RF transmitter or anticipated external RF transmission sources.

#### *3.6.2.2.2 Flight Testing*

The first consideration in CMDS flight testing is evaluating the expendable separation characteristics throughout the required flight envelope. It is important to verify, for example, that flares do not strike the airframe. Separation testing should be performed using a build up approach. The build up begins with test points where the modelling predictions show the largest separation margins and progresses toward the test conditions with the smallest margins.

Cameras mounted externally on the host platform can document separation characteristics for post-flight analysis. Chase aircraft perform several important roles during separation testing. First, the chase aircraft aircrew can provide real-time observations regarding the expected separation margins to the test conductor.

If the margins are less than expected the test team may decide to terminate the test and re-evaluate the predictions. Second, if a round strikes the dispensing aircraft the chase aircrew can advise the test aircraft aircrew about the condition of their aircraft. Finally, the chase aircrew can provide additional photographic documentation about the separation events.

CMDS performance and payload effectiveness are evaluated by testing against ground-mounted missile seekers and radiometric measurement systems, airborne pod-mounted missile seekers and radiometric measurement systems, and live-fire testing as discussed in active IRCM section. Figure 3-25 shows the Airborne Turret IR Measurement System III (ATIMS III) carried by an F-15 conducting a test on an F-18 aircraft dispensing flares. The ATIMS III pod carries up to four fully instrumented missile seekers.



- |                  |                |
|------------------|----------------|
| 1. Seekers       | 3. Televisions |
| 2. Mid-IR Imager | 4. Laser       |

**Figure 3-25: Airborne Turret IR Measurement System III – (NAVAIR Photo).**

### **3.7 LOW OBSERVABLE SYSTEMS**

LO technology is a passive form of EA and has become a significant contributor to aircraft survivability and mission effectiveness. RCS and IR signature are the two areas most relevant to EW T&E. Signature reduction reduces the detectability of the subject aircraft. It also benefits any aircraft employing or benefiting from RF or IRCM, as the lower signature results in higher J/S ratios at the victim sensor.

#### **3.7.1 LO Concepts**

The most important RCS consideration in aircraft design is vehicle shaping. The air vehicle is designed to minimise the incident energy that is backscattered toward the radar, that is, the energy is directed in

another direction. RAM is also applied to the surfaces of the vehicle to dissipate incident radar energy. There are RCS reduction techniques to address major scattering sources such as cockpits, engine inlets and exhaust, antennas, etc. Aircraft canopies can be coated with conductive material such that incident RF energy does not enter the cockpit. Engine turbo machinery is a major scattering source and inlet/exhaust designs that minimise their visibility to threat radars have proven effective. There are specially designed LO antennas to minimise their contribution to the overall RCS.

There are also a number of ways that aircraft designers can reduce an aircraft's susceptibility to IR-guided missiles. Shortwave-IR missile seekers track hot metal parts such as engine exhaust nozzles. Engine installation designs that prevent an IR missile seeker from having a line of sight to hot metal parts can significantly reduce the susceptibility of an aircraft to IR-guided missiles. Longer-wave IR missiles track the aircraft engine exhaust plume, and mixing cooling air into the exhaust can reduce the signature of the aircraft in the longer wavelengths. The signature of existing airframes can also be reduced by adding signature suppressors that either block the line of sight to hot metal parts or provide mixed cooling air. Add-on IR signature suppressors can adversely affect aircraft weight and performance.

### 3.7.2 LO Systems T&E

#### 3.7.2.1 M&S

##### 3.7.2.1.1 RCS Prediction and Mission Effectiveness Assessment

M&S plays a key role throughout the design and development of an LO air vehicle. The two interrelated areas where M&S play important roles are signature prediction and mission effectiveness assessment. Early in development, sophisticated software design tools can be used to conduct trade studies and predict the signatures of candidate aircraft designs. The modelled signature and predicted aircraft performance characteristics can be inputs to mission-level modelling simulating relevant missions to evaluate the effectiveness of the system.

M&S is also used to estimate mission effectiveness. The ability of search radars and radar-directed air defence weapons to detect and engage the air vehicle are established through engagement level modelling. These modelling efforts produce detection contours for search radars where the detection ranges are established as a function of aircraft aspect angle. The engagement modelling against terminal threat systems produces probability of kill ( $P_k$ ) grids, where the  $P_k$  is established for each threat system of interest as a function of range, aircraft aspect, and flight conditions.

An acquisition programme commonly establishes operationally representative mission scenarios against which the aircraft performance will be evaluated. The results of the engagement modelling are incorporated with modelled command and control elements of a hostile air defence system to evaluate aircraft survivability in the reference scenarios. M&S is repeatedly performed as the design evolves to estimate the effects of design changes on performance.

The accuracy of RCS data will improve throughout the programme. Initial modelling will be based solely on digital RCS predictions. As the design matures static RCS measurements are made on major component assemblies as well as sub-scale or full scale aircraft models at measurement facilities. Finally, when actual aircraft are available, in flight RCS measurements of the actual air vehicle can be performed.

##### 3.7.2.1.2 IR Signature Prediction and Detection Assessment

M&S also plays a significant role in IR signature prediction. IR aircraft signature modelling must account for a number of factors, such as engine settings, aerodynamic heating, and solar glint. The resultant model provides a database of IR spectral radiant intensity as a function of wavelength and aircraft aspect angle

that can be used in engagement level modelling. Once the IR signature of the air vehicle has been modelled, further M&S is conducted to evaluate the ability of IR sensors and guided weapons systems to detect, track, and engage the air vehicle. Atmospheric conditions have a significant effect on IR transmissivity and the model must account for factors such as humidity and particulate matter.

### 3.7.2.2 Signature Measurement

#### 3.7.2.2.1 RCS Measurement

Ground-based RCS measurement facilities support LO platform design and development by providing measured RCS data on either scale or full-sized models. These facilities allow designers to optimise platform signature during development and provide analysts with high fidelity data to support mission effectiveness M&S. RCS measurements are performed on pole-mounted models. The models can be positioned in azimuth and elevation such that the RCS can be measured at each aspect of interest. Precisely calibrated radars measure the RCS of the model at relevant frequencies and polarisations. Figure 3-26 shows an F-35 model undergoing RCS measurements. Figure 6-1 shows another type of ground test capability for the measurement of RCS of real aircraft.



**Figure 3-26: F-35 Model Undergoing RCS Measurements – (Lockheed Martin Photos).**

In-flight RCS measurement facilities, such as the Patuxent River Atlantic Test Range, are used to collect data on actual aircraft. Specialised flight profiles are flown against ground-based precision measurement radars. Flight profiles are designed to maintain the proper geometric alignment between the measurement radar and test aircraft such that the RCS measurements are collected at the required frequencies, polarisations, and azimuth and elevation angles.

#### 3.7.2.2.2 IR Signature Measurement

The IR signature of an aircraft can be measured in flight either using ground-based or airborne measurement systems. Airborne systems have the advantage of being able to measure the signature at fixed points around the platform. Figure 3-27 shows the Threat IR Generic Emulation Radiometer (TIGER) Pod which can provide all aspect air-to-air signature measurement of fixed and rotary wing aircraft and IRCM flares.



Figure 3-27: Air-to-Air TIGER Pod Mounted on F-18 – (NAVAIR Photo).

Measurements should be made at all relevant aircraft conditions. The various engine throttle settings can affect the IR signature of the aircraft. Aerodynamic heating related to airspeed also affects the aircraft’s IR signature. The IR signature of an aircraft can, with limitations, be measured using MFs similar to that shown in Figure 6-1.

### 3.8 DIRECTED ENERGY SYSTEMS

DE weapons are, by definition, EA systems because they use DE “to attack personnel, facilities, or equipment with the intent of degrading, neutralising, or destroying enemy combat capability.” [1] Two major DE areas are HPM and HEL systems. The potential advantages of DE include:

- Speed-of-light delivery;
- Invisible propagation;
- Directionality;
- Agility for engaging multiple targets;
- Deep magazines; and
- Immunity to the effects of gravity.

Disadvantages include:

- Attenuation with distance;
- Absorption by the atmosphere and moisture;
- Blockage due to weather;



- Complexity and sophistication; and
- Line-of-sight path to the target generally required.

The path to the target includes propagation physics. Propagation is a key consideration for effective use of both HPM and HEL weapons. HPM weapons tend to provide a soft-kill, or a disruption or denial effect, whereas HELs tend to be hard-kill devices.

### 3.8.1 HPM Systems

HPM weapons are systems that emit RF energy at high peak power levels and are often categorised by the bandwidth-to-frequency ratio of their waveforms. These are typically very large ratios. They have been divided into narrowband, wideband, and ultra-wideband. Peak power levels may exceed a gigawatt, but average powers may be less than a kilowatt. Some of the lower-frequency HPM devices have been called synthetic or non-nuclear Electromagnetic Pulse (EMP) or High-altitude EMP (HEMP). HPM devices have a smaller effective range than the EMP effects of a nuclear weapon. Narrowband devices tend to operate on specific electronic vulnerabilities in the target and therefore require knowledge of enemy systems to be effective. Ultra-wideband devices tend to be simpler and cheaper, using powerful transient waveforms, and requiring less knowledge of the target. A few HPM weapons function by making use of psycho-sensory or neural phenomena, rather than just high power levels, to deter human actions or cause confusion among attacking troops.

#### 3.8.1.1 HPM System Components and Operation

Figure 3-28 illustrates the basic elements of an HPM-type system. Controls may include on/off, output level and repetition rate selections. Displays may be limited to input power indications or may include some feedback from the output, providing output waveforms and power estimates. Prime power is often electrical or chemical, or both. Pulse power may be provided by an explosive, one-time burst to effect dielectric, magnetic, or ferromagnetic generation of high voltages and currents; by a discharge of capacitors through spark-gaps, or through the use of special, high-power modulation circuits coupled to large special-purpose vacuum tubes. The output waveform must be matched to an antenna for energy transfer efficiency. Voltages are very high, requiring attention to air and dielectric material breakdown.

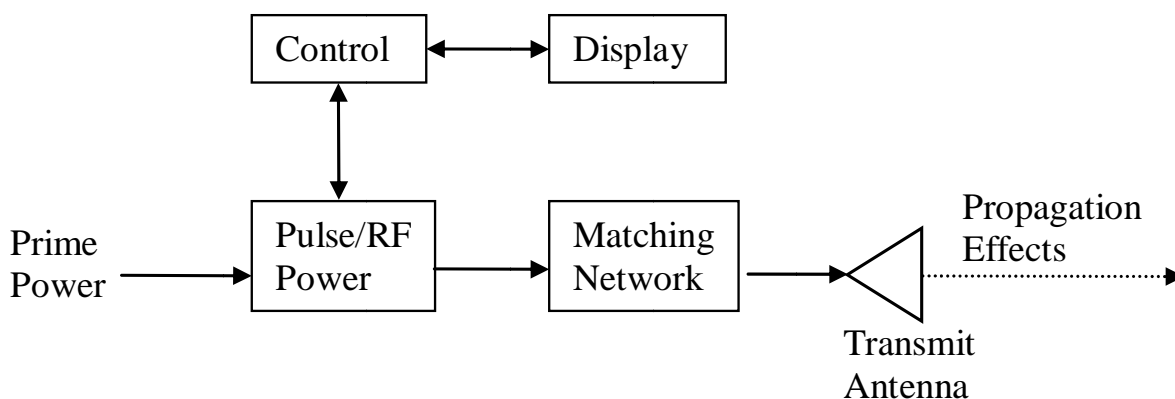

**Figure 3-28: Simplified HPM Weapon/Source Block Diagram.**

#### 3.8.1.2 HPM System T&E

HPM weapon performance testing may include measuring performance metrics or confirming the lack of degradation of specific parameters, such as, the following:



- Power;
- Efficiencies of the pulse power conversion and RF conversion;
- Losses in the path to the antenna;
- Antenna gain or directivity; and
- Beam intensity.

Ultimately, performance comes down to an effect on enemy systems or forces. Operational performance can be summarised by the ability to create an effect, probability of effect ( $P_e$ ). Those effects can be:

- Damage to a circuit;
- Upset of a system;
- Disturbance or denial of use of a system; and
- Interference while trying to employ a system.

The probability of an effect is often plotted as a family of curves against incident power levels.  $P_e$  is the most important parameter for weapons T&E. The other parameters are important for the engineering tasks of design and modelling.

Range is very important for mission planning, and can usually be derived from the parameters listed above for a particular desired effect, but may also include antenna gain as a function of angle from the source.

The often specialised nature and unique designs for DE weapons means that testing will differ between systems. Some of the common T&E approaches for DE systems are discussed in the following sections.

#### 3.8.1.2.1 *M&S*

M&S is an important part of design, testing and usage of HPM weapons due to electromagnetic propagation phenomenology. Safe and effective testing cannot be performed without accurate estimates of electrical and magnetic field levels and energy densities. Power levels and field intensity levels derived from the models are required for test planning from the beginning, meaning that M&S is a continuing part of the test programme.

#### 3.8.1.2.2 *Laboratory Tests*

Development of HPM systems and HPM test design may require iterations of analysis to quantify electromagnetic-field levels and repetitive effects testing. Multiple trials on specific electronics may result in an intensive investigation. For the ultra-wideband HPM weapon, multiple trials in the laboratory may be required to develop statistical estimates for the transient waveforms and repeatability of the output. These tests are best done at the laboratory level of development.

#### 3.8.1.2.3 *Ground Tests*

In anechoic chambers or remote open-air ranges, HPM systems are measured and characterised. Effects data on targeted systems are collected and analysed. Adequate instrumentation is essential for performance measurements and also for safety. Instrumentation requirements must include measurements of transient fields from systems or sources by field sensors that often are made using B-dot or D-dot field sensors. Sometimes, these sensors may have to be placed inside equipment to properly characterise the effects at the physical level. Fast data acquisition equipment is required since some measurements may be required under the nanosecond timeframe.

#### 3.8.1.2.4 *Flight Tests*

Flight tests will tend to be focused on system and mission compatibility. There is more emphasis on operational utility and target effects, although this may be difficult since the observable effect may be subtle. In addition to displayed information on the flight platform, instrumentation at, on, or in the target is required. Weather and other atmospheric parameters will be needed.

Unmanned HPM test platforms and target vehicles may require flight termination systems for safety. Those systems must be implemented such that they survive the HPM exposures and can still provide the safety functions required.

### 3.8.2 **High Energy Laser Systems**

HEL weapons direct light energy at targets using the properties of coherent electromagnetic radiation. The HEL systems are often categorised by the method of excitation, cooling, or the gain material. Some HELs are gas-dynamic lasers. These lasers are pumped by combustion or an energetic chemical reaction. Some lasers have a liquid gain medium or are liquid-cooled. Solid-State lasers (SSLs) have a crystalline or glass gain medium. SSLs have recently become viable contenders for HEL applications. Recent developments also include fibre-optic lasers and free-electron lasers. Fibre-optic laser development may result in easier handling and lower cost. HELs offer wavelength tunability. All lasers can be formed into a tight beam because of the property of coherence, meaning that the phase relationship is preserved to the point that interference of the waves can occur.

The best known HEL system is the YAL-1 Airborne Laser (ABL) shown in Figure 3-29. The ABL is a modified Boeing 747-400 designed to kill ballistic missiles in the boost phase. It autonomously detects, tracks, and engages ballistic missiles, and provides accurate missile launch location and impact points. [1]



Figure 3-29: The YAL-1 Airborne Laser System – (USAF Photo).

### 3.8.2.1 HEL System Components and Operation

Figure 3-30 illustrates the basic elements of an HEL-type system. Prime power can take different forms, such as chemical or electrical. The prime power provides energy to the pump mechanism. Lasers must have a pump to put energy into the gain medium such that a population-inversion of the laser energy states is created. Most lasers require an efficient cavity to support multiple passes of photons through the gain medium. Controls may be complex due to the requirement for beam steering and control, including precise pointing. Propagation includes not only attenuation effects, but optical effects from atmospheric turbulence, scattering, or a heterogeneous path. As a result, the beam control may include optics to compensate the beam for the atmospheric effects for longer-range systems.

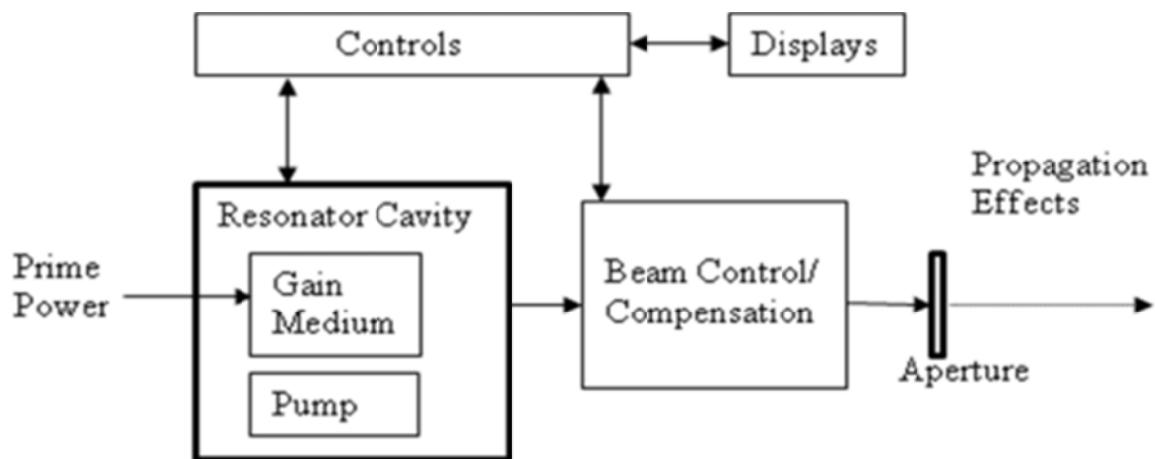

Figure 3-30: Simplified HEL Weapon/Source Block Diagram.

### 3.8.2.2 HEL Systems T&E

Testing of lasers will vary depending upon the physics phenomenon that produces coherent emission. These lasers have different test objectives based upon the unique properties of the medium and proposed effect. They will, however, have certain input and output characteristics and figures of merit that allow comparison and produce some commonality in weapons applications.

#### 3.8.2.2.1 M&S

Because of the EM propagation phenomenon, M&S is an important part of design, testing and usage. Power levels and field intensity levels derived from the models are required for test planning from the beginning, meaning that M&S is a continuing part of the test programme. Because of the often specialised nature and unique designs for DE weapons, the testing will differ between systems. Some of the common T&E approaches for DE systems are discussed below.

#### 3.8.2.2.2 Laboratory and Ground Tests

Laboratory testing of concepts and demonstrators is likely to be very technically complicated. Testing of sub-systems is likely to be extensive due to the complexity and the need for a build-up approach.

In the laboratory, key laser performance characteristics can be accurately measured and characterised. Output is usually measured by instrumentation that records multiple temperature measurements in a beam dump, converting it into a calorimeter.

Common laboratory and ground test performance measures include:

- Power;
- Brightness (in units of power per solid angle); and
- Delivered fluence (in joules per unit area).

The amount of fluence, or flow of energy, on a target is related to the beam quality. Beam quality is generally a ratio relationship between the total energy deposited to an ideal amount of energy, expected in a diffraction-limited system. There are several parameters used to describe beam quality, to include Strehl, M-squared, and power-in-the-bucket. Formulas and algorithms for predicting and calculating these from test data are found in textbooks and scientific publications.

Based on laboratory and ground test results, three operationally important measures can be determined:

- Probability of kill ( $P_k$ );
- Required dwell time in units of seconds; and
- Effective range, in miles or kilometres.

Some of the common data requirements involved in integrating a HEL into a flying platform are power consumption, charging timelines for the energy storage elements, heat dissipation, and the ability to focus the beam in the flight environment. For production versions of HEL systems on a flying platform, compatibility testing, EMI/EMC, EW, HPM susceptibility, and network-centric interoperability tests may be required. These tests are done more efficiently in the appropriate ground facilities, such as installed-equipment facilities and anechoic chambers than during flight tests. For the flight environment assessment, the beam focus estimates must account for the aerodynamic effects around any exit apertures.

#### 3.8.2.2.3 *Flight Tests*

Early flight testing to reduce the risk of adding an HEL to an aircraft may be prudent. These tests may involve the aerodynamics changes for installing turrets, fairings, and windows. Early flights with sub-systems or surrogates may be used to verify heat removal and other form, fit, and functions of the interfaces to a laser pallet or system.

Final flight testing of HEL weapons will tend to be more operational-effect oriented. Targets may be used with various instrumentation schemes. A successful effect is likely to be a visible one that includes significant damage, as opposed to HPM where the effect is more subtle. Although the effect may be obvious from visual and infrared sensors and human observations, failures to achieve an effect may be much less clear. As a result, instrumentation on and around the target is required. Pointing and tracking may have to be assessed at lower power levels to avoid damage to sensitive detectors and data acquisition systems on the targets. To determine functions that predict  $P_k$ , target fluence levels will be required for each set of trials. Weather and other atmospheric parameters will be needed. Their effects on propagation must be modelled and verified.

Safety requirements for the test range may include monitoring the intended beam as well as inadvertent reflections or glint, to avoid inadvertent propagation to populated areas or other craft. Flight termination systems on targets must be implemented such that they either survive or avoid exposures and provide the safety functions required.

## 3.9 REFERENCES

- [1] United States Air Force, "The Air Force Handbook 2007", 2007.

- [2] NATO Industrial Advisory Group SG-105: Study on NATO Aircraft and UAV Self Protection Systems – Flare/Chaff round Interchangeability: Final Report. NIAG-D(2007)0022-REV001, 31 October 2007.

### **3.10 FURTHER READING**

Chrzanowski, E.J., “Active Radar Electronic Countermeasures”, Norwood, MA, Artech House, Inc., 1990, (ISBN 0-89006-290-0).

Golden, A., “Radar Electronic Warfare”, New York, New York, American Institute of Aeronautics and Astronautics, Inc., 1987, (ISBN 0-930403-22-3).

Hecht, J., “The Laser Guidebook”, Blue Ridge Summit, PA, TAB Books, 1992, (ISBN 0-8306-4274-9).

Hecht, J., “Beam Weapons: The Next Arms Race”, Lincoln, NE, iUniverse.com, Inc., 2000, (ISBN 0-595-09450-3).

Lynch, D., Jr., “Introduction to RF Stealth”, Raleigh, NC, SciTech Publishing Inc., 2004, (ISBN 1-891121-21-9).

Schleher, D.C., “Electronic Warfare in the Information Age”, Norwood, MA, Artech House, Inc., 1999, (ISBN 0-89006-526-8). Chapter 8: DEW and Stealth Technology.

Stimson, G.W., “Introduction to Airborne Radar”, Raleigh, NC, SciTech Publishing Inc., 1998, (ISBN 1-891121-01-4).

Van Brunt, L.B., “Applied ECM”, Dunn Loring, VA, EW Engineering, Inc., Vol.1 (1978, ISBN 0-931728-00-2); Vol.2 (1982, ISBN 0-931728-01-0); Vol.3 (1995, ISBN 0-931728-03-7), Ch.7 Test and Evaluation.

Weigand, R.J., “Radar Electronic Countermeasures System Design”, Artech House, Norwood, MA, 1991, ISBN 0-89006-381-8.





## Chapter 4 – T&E OF EP TECHNIQUES

### 4.1 INTRODUCTION

This chapter describes EP techniques and procedures. A general discussion of EP testing is presented and a simplified test example is presented to illustrate how the EW test process applies. Finally, EP through Emission Control (EMCON) and associated testing are discussed.

### 4.2 EP TECHNIQUES AND PROCEDURES

The EW division of EP differs from the ES and EA divisions in an important way. ES and EA usually employ dedicated systems to accomplish a specific purpose. EP techniques are normally incorporated into EW and non-EW systems as a means of protection from hostile EA. EP can also be procedural in nature such as employing Operational Security (OPSEC) measures, EMCON, and spectrum management.

All unprotected sensor systems, such as radar, are vulnerable to some form of EA. For example, an unprotected airborne interceptor's FCR would be vulnerable to a basic EA technique such as a Velocity Gate Pull-Off (VGPO). VGPO is an EA technique that attempts to deceive the FCR by stealing its velocity gate and injecting false target information into the FCR. A radar designer knowing that an adversary's EA will likely attempt to accomplish a VGPO will therefore incorporate logic, i.e., Anti-VGPO (AVGPO), into the FCR to recognise that a VGPO technique is being attempted and to negate it. Techniques such as AVGPO are often called ECCM. [1],[2] This also highlights the value of OPSEC and the need to protect information about potential vulnerabilities of friendly equipment from hostile interests. When hostile EA system developers design their systems they will use all known vulnerabilities to optimise their EA technique's effectiveness. If information about potential vulnerabilities is denied to them, they need to adopt more general techniques that are usually less effective than the ones designed to exploit specific vulnerabilities of the radar.

EP techniques tend to be the result of developments of EA capabilities. Most EP techniques are defined in relation to how they counter a specific EA threat. Usually, the EP technique is some improvement in the system design that counteracts the effect(s) of a specific EA technique; therefore, it is difficult to understand the purpose of a specific EP technique without knowing the EA technique that it is designed to counteract. This close relationship between EA and EP means that EP testers must plan, conduct, and evaluate testing based on a complete understanding of both the SUT and the threats that challenge it.

The EP test requirements most often encountered will involve ECCM of airborne radars. Figure 4-1 shows a block diagram of a generic airborne radar.

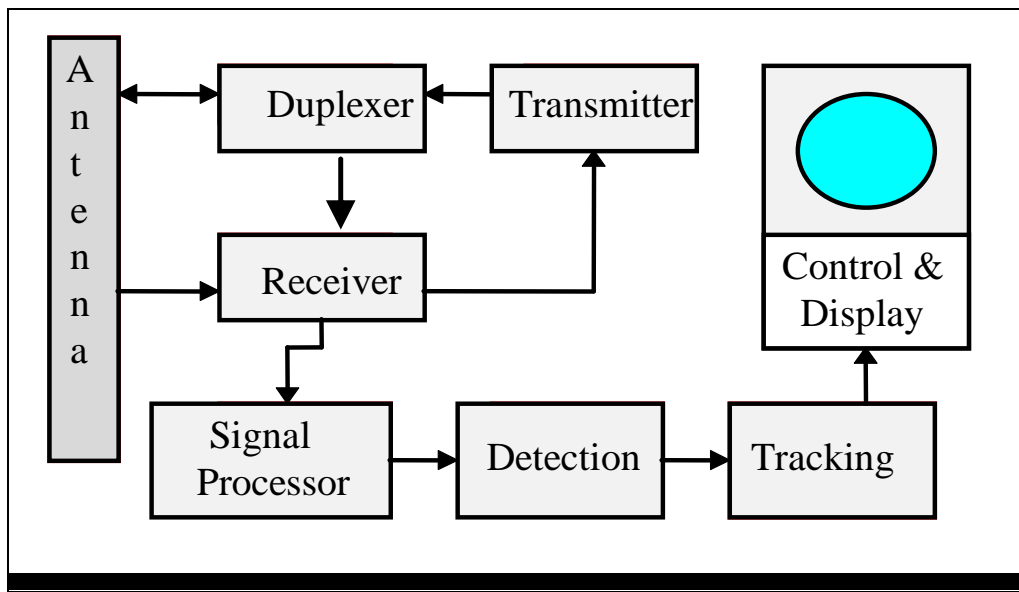

Figure 4-1: Generic Radar Block Diagram.

Each element of this radar is a potential victim of EA; therefore, some EP technique should be considered. The antenna's greatest vulnerability may be to stand-off jamming introduced through the sidelobes. The associated EP technique is to reduce sidelobes to the lowest possible level and, as is common nowadays, to equip the radar with a guard antenna which has an antenna pattern which covers the sidelobes. The radar can compare the jamming power from the two antennas and by that suppress signals introduced in the sidelobes. A similar relationship exists with the antenna's sensitivity to cross-polarised signals. If the antenna is designed for low cross-polarisation response, then it will be more robust against EA techniques that rely on jamming with cross-polarised signals.

The radar transmitter can protect against some EA techniques by having features such as frequency hopping, PRF stagger or jitter, pulse width modulation or compression, or other parametric diversity; a broad tuning range; or high transmit power. Each of these features is a valid EP technique and will require specific testing in order to characterise the radar transmitter's overall performance in a jamming environment.

Similarly, the radar receiver design can incorporate features to reduce its vulnerability to common EA techniques. High local oscillator and first Intermediate Frequency (IF) will result in increased image frequency rejection thus improving the receiver's ability to operate in a jamming scenario. Recent improvements in signal processing have led to major improvements in EP and pose significant new challenges for the EA designer. As digital signal processor components have increased in both speed and density, functions within radar signal processors have become more resistant to both deceptive and power-based EA techniques. Some features of signal processing found in modern airborne radars include programmability, high range and Doppler resolution, and signal processing reserve capability in both memory and computing resource timeline. Each of these features can result in important improvements to radar's EP capability. The primary objective of EP T&E is to characterise the radar's resistance to various EA techniques and assess its suitability for operation in an EW environment.

### 4.3 TESTING EP TECHNIQUES

The constant evolution of EP and EA provides some interesting challenges to the tester. As with EA, detailed knowledge of the threat is the tester's greatest resource. The following paragraphs describe

how test resources can be applied at each level to evaluate the performance and effectiveness of the EP techniques.

### **4.3.1 Modelling and Simulation**

Many EP techniques are based on complex and sensitive circuitry in the system being protected. As such, all elements of the EW test process should be considered in planning EP tests. M&S will be of particular value in both the test planning and evaluation portions of the test process. A digital model of the SUT can be used to analyse potential effects of jamming or other EA techniques. Antenna designs can be evaluated for their sidelobe characteristics that in turn will provide insight into the system's vulnerability to noise jamming introduced into the sidelobes.

The signal processing circuits of radar systems are excellent candidates for digital models. These models can be used both in the design of the signal processing circuits and as a tool to evaluate susceptibility to various jamming techniques. Current EW industry trends are to establish standards for models that permit a compliant digital model of a system in the design phase to be evaluated in the presence of previously established threat models. This approach permits both designers and testers to assess the behaviour of a new radar system with respect to various generic and specific EA techniques. Based on the results from this step in the test process, testers can determine those conditions most likely to reveal performance limitations or other problems in the SUT.

### **4.3.2 Ground Test**

Various laboratory or ground facility tests will prove invaluable in developmental testing of EP functions. The majority of the EA techniques that may be overcome through some form of EP are based on the characteristics of EM waveforms, not on the dynamic properties of ships, land vehicles, aircraft, or missiles. Therefore, if the SUT, such as an airborne radar, is subjected to jamming signals while in a laboratory or spread-bench environment, the results observed will usually be indicative of the eventual installed system performance. Tests in SIL and HITL facilities will permit a large number of trials, with a high degree of repeatability at a low cost. Results from these tests can be quickly and easily compared with results from the digital M&S previously completed. Differences between the model results and those obtained in the SIL or HITL should be investigated and resolved. Appropriate updates to the models used are made before progressing to more expensive and complex test conditions.

One portion of nearly all EW and avionics systems that is particularly sensitive to installed performance is the antenna or sensor aperture. For the case of RF systems, antenna performance can be significantly altered due to installation effects such as other nearby antennas acting as parasitic oscillators or other parts of the aircraft causing blockages to the antenna pattern. Tests in ISTFs can efficiently lead to the evaluation of such effects. Not all ISTFs can support the actual radiation of RF signals required for measurement of antenna system performance. The tester must always be careful to select facilities in each test category that can support the specific types of tests deemed necessary for the system of interest. For instance, if the installed performance of the antenna systems is well known but a concern exists about the integration of new signal processing circuits with other elements of an aircraft's avionics, then operation in an ISTF that permits free-space radiation of RF signals may not be necessary. A smaller facility with lesser anechoic properties will suffice. If, on the other hand, the SUT has an uncharacterised antenna system and must operate in a complex radiated electromagnetic environment, then the test team should consider using an ISTF with broad anechoic properties and a wide-operating frequency range.

### **4.3.3 Flight Test**

Flight testing is usually the final step and should hold little potential for surprise if the previously described steps are carried out. However, it is possible that some aero-mechanical effects not simulated in

the earlier stages will cause problems. Movement of antennas due to flutter or aeroelasticity effects can result in erroneous Direction Finding (DF), ranging, or velocity determinations.

## **4.4 ECCM TEST ILLUSTRATION**

The following example illustrates the test process for a notional airborne FCR with an EP technique designed to mitigate the effects of sidelobe jamming. Assume for this example:

- SUT is an Airborne Interceptor (AI) radar.
- A digital model of the radar and threat jammers exists.
- Radar antenna pattern has been previously characterised in both azimuth and elevation.
- Radar's primary EP technique to negate effects of barrage noise jamming is sidelobe cancellation.
- For HITLs and ISTFs, a threat jammer simulator is available with adjustable power output.

### **4.4.1 Test Objectives**

During test planning meetings the military end user, the radar manufacturer, PSI and testers determine that the military end user is particularly interested in how the radar system will perform in the presence of SOJ barrage noise jamming. Barrage noise is an EA technique that produces broadband noise energy to mask the reflected energy from a radar. When applied by an SOJ, the noise is introduced into the radar sidelobes to mask returns that are occurring in the main beam. The success of barrage noise jamming is primarily a function of J/S. These factors will help to determine appropriate test objectives, plan test activities, and determine the data requirements to support an evaluation. The first step is to determine the test objective. There will be one simple test objective in this example to demonstrate the process. The test objective is: Determine the minimum jamming power required to obtain the specified J/S at the input to the radar receiver at various azimuth angles between 10 and 45 degrees off the nose of the test aircraft.

### **4.4.2 Pre-Test Analysis**

A key to effective testing is to develop an understanding of the SUT, its intended operating environment, and the strengths and weaknesses of the threats it will encounter. Developing this understanding is the first element of pre-test analysis. As shown in Figure 4-2, there are two areas of interest defined, a 35-degree sector on the left and a 35-degree sector on the right. The jamming signal must be within the bandwidth of the radar receiver to be effective. The antenna pattern for the radar antenna will be an important consideration in determining the angular resolution for testing. For this example, it is assumed that the antenna pattern is of adequate consistency to permit measurements to be taken at 5-degree increments. The initial characterisation of the antenna pattern would have been accomplished in a measurement facility specialising in RF antenna measurements.

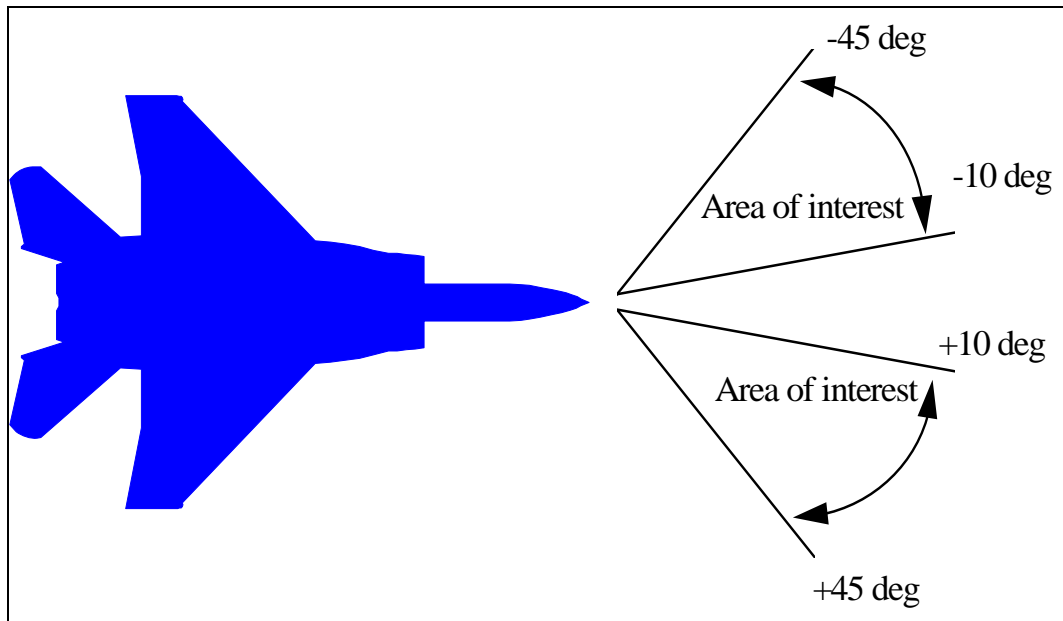

Figure 4-2: Areas of Interest.

The EP technique used in the example radar is sidelobe cancellation. This technique utilises auxiliary antenna elements to receive the jamming signal, determine its effect, and cancel that effect in the main antenna channel. In order to evaluate the effectiveness of the sidelobe canceller, the test will be conducted with and without the EP technique enabled. Since the radar antenna is a critical element in the vulnerability of the radar to stand-off jamming, all tests will be conducted with RF radiation through the antenna.

The pre-test analysis we must define the test concept, determine test points, predict outcomes, establish analytical processes that will be applied, and decide what data must be acquired. Since there is a digital model of both the SUT and the SOJ, these tools can be used to determine if there are critical angles or frequencies at which the jamming will be particularly effective, or the EP technique is particularly ineffective. The model will also be helpful in determining what data need to be collected and the requirements for range, resolution, and accuracy of that data.

### 4.4.3 Test Execution

The next step is to execute the test. This step will be repeated several times, using various test resource categories as the confidence in the SUT increases. The results obtained will be compared to those predicted during the pre-test analysis after each iteration. The results will be used to correct or revise the models and to resolve differences between actual and predicted results.

#### 4.4.3.1 HITL Testing

The first tests will be accomplished in a HITL with the SUT in a ‘spread bench’ configuration permitting easy access to test points with generic laboratory test equipment such as spectrum analysers and oscilloscopes. The radar antenna, auxiliary antennas, and the jammer simulator transmit antenna will be located in a small anechoic chamber where RF radiation can be accommodated with adjustable power levels. During this testing precise measurements can be made of the actual power levels and J/S ratio at each point of interest in the antenna pattern. Data can be either hand recorded or automatically logged by the test facilities instrumentation support system.

#### **4.4.3.2 ISTF Testing**

Testing the radar in its installed configuration under precisely controlled conditions can be accomplished in an ISTF. This will be an important test since it will be the first opportunity to measure the system performance with installation effects accounted for. Both facility and aircraft instrumentation systems should be utilised during this phase of testing. It will provide a correlation between the test aircraft instrumentation system that will be used during flight test and the facility instrumentation that is the primary data acquisition source during the ISTF tests. Large amounts of data can be easily collected in this environment with a high degree of repeatability. These data will form the basis for an accurate statistical baseline of system performance. Both HITL and ISTF testing support a tightly controlled RF environment where only the signals of interest are present. This will not be the case in flight test.

#### **4.4.3.3 Flight Test**

The final phase of the test project will be conducted in flight on an OAR. Three aircraft will be used. The first aircraft will simulate the actions of an adversarial SOJ aircraft. The second aircraft will represent a threat target aircraft. The third aircraft, the test aircraft, will carry the SUT and be instrumented to provide either onboard recording or telemetry of critical parameters needed for evaluation of the SUT. Time Space Positioning Information (TSPI) for all three aircraft is required. These data will be used during post test analysis to determine the exact position of the jammer and target with respect to the SUT radar antenna.

Flight profiles for all three aircraft will be established to maintain the jammer aircraft within the 35-degree sector on either the left or right side of the test aircraft. During this phase of testing the test objective is modified to provide a more operational focus. The objective is now redefined as: *Determine the minimum jamming power required to defeat the radar's ability to detect, track, and display a one-square-meter target with stand-off jamming at various azimuth angles between 10 and 45 degrees off the nose of the test aircraft.* This revised objective creates a number of new requirements. The objective describes a target aircraft with a RCS of one square metre. While the aircraft available to serve as a target may not directly meet this requirement, data obtained during testing can be corrected for any difference in the RCS. This does, however, require high accuracy and resolution TSPI capability on the open-air range. Also, the primary indicator of jamming effectiveness will now be the pilot of the test aircraft. When the jamming is sufficient to obscure the target on the pilot's display, then we will consider that the EP technique is ineffective. While the precise data gathered during the previous phases of testing are necessary to efficiently develop and improve the SUT, these operational data will ultimately determine whether or not the system will be acquired and fielded.

#### **4.4.4 Evaluation**

The system manufacturer, PSI and the military end user may have different views of what the results mean; the manufacturer may use the results of testing to demonstrate that all specifications have been satisfied, while the military end user may determine that based on test results, the system will not satisfy the operational requirements. Due to the differences in interpretation of test results and the potential economic and operational impacts associated with these interpretations, evaluation is one of the most critical and controversial elements of the test process. To the greatest extent possible, all parties involved in the development and test of a system reach agreement prior to the start of testing as to what data will be used in the evaluation, and what calculations and statistics will be applied to the data. Finally, everyone must reach agreement as to exactly what constitutes success or failure.

For the example test the problem was bounded to some degree in the test objectives' statement. For the flight test objective, only data acquired when the jamming aircraft is within the 10 to 45-degree sector on either side of the test aircraft will be used. The evaluation of the test results will generally be communicated through an interim or final report. This report should clearly state any constraints or



limitations on the testing, what was observed, what was concluded from those observations, and any recommendations resulting from those conclusions. If, based on the evaluation, the decision makers can verify that any operational risks associated with fielding the system are acceptable, and that user needs are adequately satisfied, then testing can be declared complete. If the evaluation leads to a conclusion that the SUT requires additional improvement prior to acceptance or fielding, then another cycle of the test process will occur.

## **4.5 EP THROUGH EMISSIONS CONTROL CAPABILITIES**

In addition to the ECCM techniques discussed above, there are passive approaches to EP. One of the most significant is EMCON. EMCON addresses both intentional and unintentional emissions.

### **4.5.1 EMCON Concepts**

The most direct means of limiting an adversary's ability to apply EA techniques is by rigid control of friendly EMCON. As a simple example of this process, consider an ARM targeted at a friendly radar site. Since the ARM homes in on the RF radiation from the radar, it will lose that guidance if the radar transmissions are ceased. The planned cessation of the radar emissions would be considered a form of EMCON and would clearly be an effective method of EP.

IADS typically contain passive RF sensors to detect and track hostile aircraft. These sensors can track both intentional and unintentional RF radiation coming from the air vehicle. An air vehicle should have an RF management system to control all onboard RF transmissions. Unnecessary emissions should be eliminated and in the event that they cannot be eliminated they should be characterised so that their effects can be procedurally mitigated.

### **4.5.2 Testing for Unintentional Emissions and EMCON Capabilities**

Virtually all electrical and electronic components on an aircraft have the potential to radiate or re-radiate RF energy, which may be detected and intercepted by an adversary. While some of these potential emissions can be observed during early phases of development, it is most often the case that they are discovered after all systems are installed and integration in the host platform has begun. As a result, ISTFs are frequently used to characterise these unintended emissions.

#### **4.5.2.1 Ground Tests**

Large anechoic chambers are most useful in conducting tests to determine the exact nature and source of all signals radiated from an aircraft during operation. One approach frequently used is to establish a matrix of all possible switch combinations and then step through each configuration while using a calibrated, high sensitivity receiver to sweep through the entire range of frequencies to be evaluated. If energy is detected with a particular combination of aircraft equipment energised, then engineers can isolate the exact source. At this point both the user and designer must determine what action is to be taken to either reduce the emission or accept the condition.

While this type of testing is time consuming and requires specialised facilities and equipment, it has proven to be the most efficient manner to locate specific sources of unintentional emissions. Of course, intentional emissions can also be used to detect, locate, and engage an aircraft and must also be characterised. Again, the anechoic chamber is an efficient and cost effective location for this task.

#### **4.5.2.2 Flight Tests**

The results from ISTF tests can be used along with digital models of threat systems to determine an aircraft's susceptibility to such threats. In many cases actual flight test against simulated threats and

RF measurement systems can be employed to evaluate susceptibility. While determination of the exact source of the offending radiation may be difficult or impossible in an OAR environment, flight tests do provide the most realistic conditions. It is not unusual to regress to ISTF testing after the first round or two of flight testing. This iterative approach will generally converge on the best balance of emissions reduction and operational utility. Operational tests and some developmental tests on an OAR are accomplished using operationally representative flight profiles against typical threat laydowns. Through careful manipulation of the flight profile relative to the threat simulator placements, specific conditions thought likely to occur in actual combat can be evaluated. The analysis of system performance during such testing provides the best overall assessment of military worth.

#### **4.6 REFERENCES**

- [1] Skolnik, M.I. (Ed.) Radar Handbook, 3<sup>rd</sup> Edition. McGraw Hill, Boston, MA, 2008. ISBN 0-07-057913-X. Chapter 9 Electronic Counter-Countermeasures, by A. Farina.
- [2] Johnson, S.L. Radar Electronic Counter-Countermeasures. Artech Radar Library, 1980, ISBN 978-0-89006-079-7.

#### **4.7 FURTHER READING**

Chrzanowski, E.J., "Active Radar Electronic Countermeasures", Norwood, MA, Artech House, Inc., 1990, ISBN 0-89006-290-0.

Golden, A., "Radar Electronic Warfare", New York, New York, American Institute of Aeronautics and Astronautics, Inc., 1987, (0-930403-22-3).

Maksimov, M.V. et al. Radar Anti-Jamming Techniques. Artech House, 1979. ISBN 0-89006-078-9.

Van Brunt, L.B., "Applied ECM", Dunn Loring, VA, EW Engineering, Inc., Vol. 1 (1978, ISBN 0-931728-00-2); Vol. 2 (1982, ISBN 0-931728-01-0); Vol. 3 (1995, ISBN 0-931728-03-7).

Weigand, R.J., "Radar Electronic Countermeasures System Design", Artech House, Norwood, MA, 1991, ISBN 0-89006-381-8.

## **Chapter 5 – T&E ASPECTS OF EW SYSTEM ARCHITECTURE**

### **5.1 INTRODUCTION**

The approach to testing any specific EW system or function depends on its architecture. Testing and the subsequent evaluation of standalone systems are relatively straightforward. When the EW system is combined with other systems and sub-systems on a single platform, both the quantity and nature of interactions which must be considered grow substantially. This chapter focuses on testing federations of equipment and systems, and integrated systems.

The even more complex case of Multi-Platform Geo-Location using RWR/ESM as a threat Emitter Location System (ELS) is not explicitly covered in this Handbook. Many of the considerations are similar to the single platform integrated EW system, but with the added complication of data links between the platforms concerned. Other information is available to the interested reader. [1]

### **5.2 STANDALONE EW SYSTEMS**

The simplest category of EW systems, from a T&E point of view, are those having minimal interaction with other systems on the same platform. These standalone systems can usually be evaluated without a rigorous evaluation of the performance of other aircraft functions. Of course, interoperability and EMI issues must be considered for standalone systems.

#### **5.2.1 Standalone System Description**

Standalone EW systems are those systems that do not depend on data, information, cueing, or other functions from other EW or avionics systems on the platform. These systems generally have a specific single function such as radar warning, jamming, or chaff dispensing. Standalone system testing is relatively simple; the system is exposed to the expected threat environment and observed for the correct response.

#### **5.2.2 Standalone System Testing**

A standalone RWR is designed to provide the pilot with visual and audio warnings when the aircraft is illuminated by one or more threat radar systems. As discussed in Chapter 2, specific tests are performed in both ground and flight environments to measure and establish the performance of each major functional element of the RWR. The antennas are characterised individually and in their installed configuration to verify their frequency, spatial coverage and gain performance. Receiver tests are conducted to determine sensitivity, selectivity, and other key parameters. The signal processing function is tested to ensure that all threat signals specified for the system are properly categorised. Finally, the Man-Machine Interfaces (MMIs) are evaluated for correct operation. While this overall process may require hundreds of individual tests, the evaluation of results remains relatively simple and the test conditions can be easily achieved. Each element of the system either functions as specified, or not; each test condition is discrete and has little or no dependence on other test conditions.

### **5.3 FEDERATED EW SYSTEMS**

Federated systems represent an increased level of complexity. Additional interfaces have to be considered in the design of the test program. A depiction of this architecture is shown in Figure 5-1.

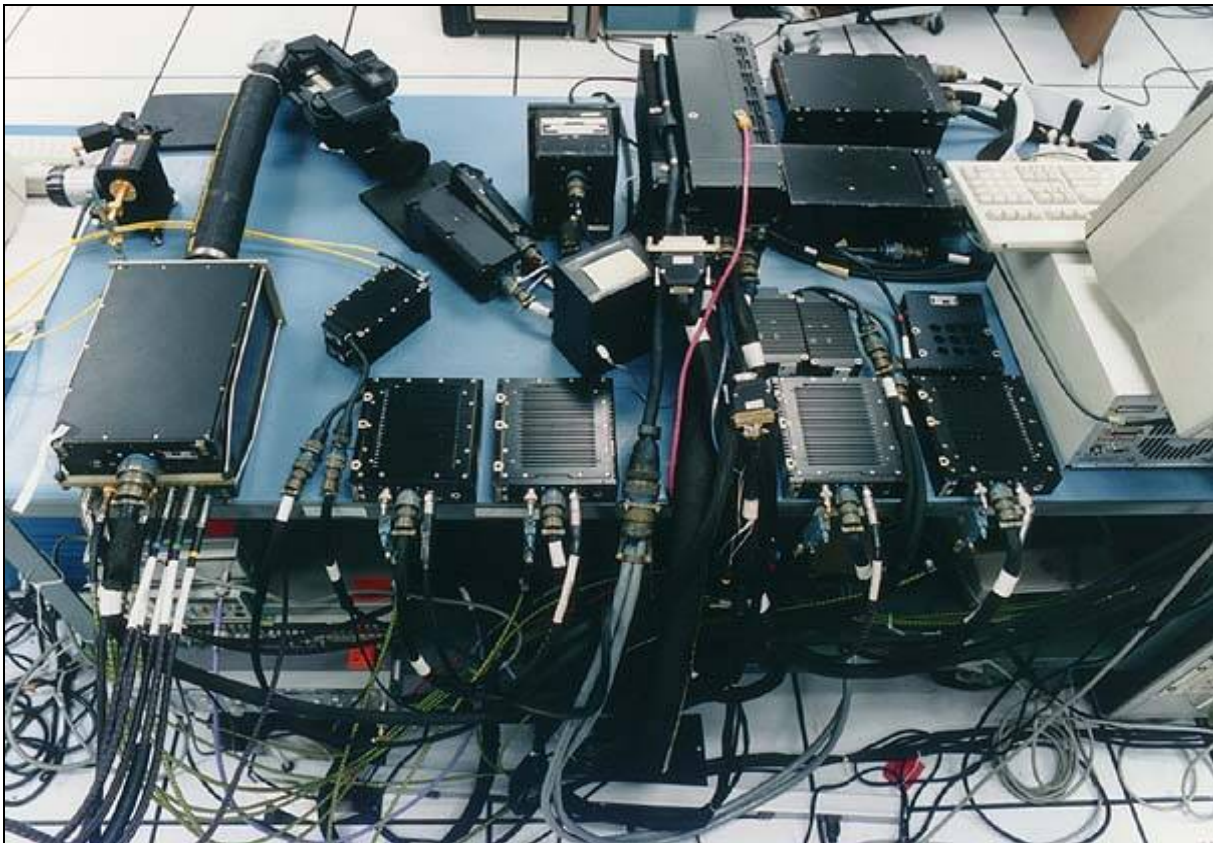

Figure 5-1: Federated System in HITL Test at ECSEL Facility, Pt. Mugu, California.

### 5.3.1 Federated System Description

Federated systems are those systems which maintain their own functional identities or boundaries, but are dependent on data, information, cueing, or other functions from other systems outside of those boundaries. Most avionics and EW systems of the late 1970s through the early 1990s have exhibited this characteristic.

The testing of such systems is considerably more complex than the standalone case previously discussed. The causes of this complexity are best understood by reviewing an example test process for a federated RWR and RF jamming system. Generally, such systems still have their own control panel and displays.

### 5.3.2 Federated System Testing

For this example, consider that the RWR and jammer are installed on the same platform and designed to work against the same set of threats. They share a common threat database or MDF. When the RWR detects a threat it will be displayed on either a dedicated system display or on a MFD in the cockpit. The display will show a unique symbol representing the threat type, azimuth, and estimated lethality. The pilot also receives a warning tone in his headset. Upon command from the pilot, the threat identification and location data are passed to the jammer sub-system. The jammer determines the optimum jamming response for the detected threat, tunes a receiver to the proper frequency, and emits the necessary RF energy. If the jamming is effective, the RWR will detect that the radar is no longer tracking the aircraft. From this scenario the example test program can begin to be structured, the test resource requirements determined, and an evaluation process planned.

Two common MOPs for the example system are:

- Response time for the RWR to detect each threat signal in the MDF.
- Response time to initiate the optimum jamming waveform.

Many other MOPs apply to this type of testing, but these two serve to illustrate the point. While the first MOP appears to focus on the RWR standalone performance, there is a potential for interaction with the jammer through the MDF. If both the jammer and the RWR attempt to access the MDF simultaneously, there may be a delay in the data needed by the RWR. Consequently, testing must be structured to acquire data under various operating conditions for both the RWR and the jammer. The data collected must be categorised to reflect the operating conditions to determine if there is a significant delay imposed by multiple systems sharing a common MDF. The system specification requirement identifies how much delay acceptable. Certainly, the standalone performance of the RWR will be a dominant factor in this objective, but additional testing to ascertain the overall performance of the federated system is of paramount importance to the military end user.

The second MOP clearly implies evaluation of the fully federated system. The RWR, jammer, shared MDF, displays, and the pilot all play an important role in overall system performance and effectiveness. To fully analyse and evaluate the results of this test, insight into the performance of each individual component of the system is necessary. The evaluation should not just assess if improvements are needed, but if so, which part of the system is the best candidate for improvement. This MOP also brings into play the human operator; a component with a high degree of variability. In order to appreciate the operator's effect on overall system performance, data will need to be collected under a wide range of operational conditions, and with a range of operators.

All of this leads to the conclusion that test of federated systems brings about an increased burden on the test planning and analysis processes over that of the standalone systems test. The same facilities will be used, but the number of test runs or flights may increase significantly as the system complexity grows.

## **5.4 INTEGRATED EW SYSTEMS**

Some combat aircraft designs from the late 1990s onward have moved from the relatively simple federated approach to an extensive integration of EW and avionics functions. The U.S. Air Force F-22, shown in Figure 5-2, is an example of this integrated approach. Functional integration offers numerous advantages to system designers while creating complex challenges to testers.





**Figure 5-2: F-22 Employs a Fully Integrated Avionics and EW Suite – (USAF Photo).**

The Eurofighter Typhoon also has an integrated DAS, comprising EuroDASS ‘Praetorian’ (ESM-ECM, TRD, MWS and LWS), as shown in Figure 5-3, Defensive Aids Computer, and flare and chaff dispensers.



**Figure 5-3: Praetorian Components – (© SELEX Galileo 2008).**



### **5.4.1 Integrated System Description**

Integrated EW systems are not just a combination of standalone systems linked together as is the case with the federated approach. Rather, integrated systems tend to have a homogeneous functional identity. There is no discernible boundary between sub-functions such as radar warning, missile warning, jamming, or other EW activities. Most, if not all, components in the system may be shared between the sub-functions on the basis of complex scheduling and resource control algorithms.

Modern highly integrated systems employ a number of apertures, e.g., antennas and IR detectors, to perform a variety of functions. EW and non-EW system designers no longer necessarily treat these apertures as dedicated to a single sub-system. An antenna on a modern fighter aircraft FCR will generally be a high-gain, electronically steered, phased array that can be tasked to support sensing functions for other onboard systems.

### **5.4.2 Testing Integrated EW Systems**

Testing of isolated functionality becomes difficult, if not impossible, with the operational software<sup>1</sup> in place. Flight tests will reveal little of the source of performance problems with integrated systems. ISTF and HITL test facilities that can make large numbers of test runs with precisely controlled conditions and extensive instrumentation are essential to the T&E of integrated systems.

The OAR remains useful in establishing the overall effectiveness of integrated EW systems, as discussed in Section 6.8. However, in order to evaluate the system effectiveness in conditions outside that which can be demonstrated with OAR resources, the tester must rely on digital M&S and ground-based resources. The current trend is to combine digital models with hardware threat and environment simulations to provide controllable, repeatable stimulation of the entire test aircraft in an ISTF.

This capability to immerse the entire aircraft in a controlled and representative EW environment requires that all signals of interest (RF, IR, UV) be simultaneously generated in a coherent manner. Information content must be consistent among and between emissions from both the SUT and the simulated environment. All objects used in the test scenario must appear to exist at the right time and place; that is, coherency must exist in all domains detectable by the SUT.

These requirements drive ISTF signal and scene generation and scenario control software to the far extreme of current technical capability. A simple example serves to help understand this demand on test resources. Assume the integrated EW system being tested can sense RF and IR emissions from a potential threat aircraft and correlate this sensor data with its own radar detections and tracks. The test facility will then be required to generate a radar return representative of the threat aircraft's RCS, an IR scene, and other RF emissions all coming from the intended target position. Looking at this requirement in the time domain, all simulations must present realistic target motion and the resulting changes in physical characteristics of each signal. Radar target returns must be modulated with the correct Doppler, scintillation, and other characteristics to permit a viable test of a coherent processing AI radar.

If, due to minor time or space positioning errors in the simulation, the IR emissions from the target were displaced from the radar target simulation, then the SUT may declare two targets rather than one. Clearly, the eventual outcome of a one-versus-one engagement should be different than a one-versus-two engagement. This difference would invalidate the planned test.

For ISTF testing of modern integrated EW systems, this simple example must be replicated many times to represent realistic threat densities. Very sophisticated and costly threat and signal generation systems, scenario control software, digital models, and instrumentation are needed to accomplish these high-

---

<sup>1</sup> Operational software in this usage means the OFP and the MDF. The terminology varies with Nations and services.

density, high-fidelity simulations. However, in spite of the cost and complexity involved, such test capabilities can pay great dividends in understanding the behaviour of integrated EW systems and isolating hardware and software failures, prior to flight test and combat use.

### 5.5 REFERENCES

- [1] NATO Industrial Advisory Group, Study Group SG-79 'Emitter Location and Data Links to facilitate Suppression of Enemy Air Defence': Final Report. NIAG-D(2006)0009. February 2006.

### 5.6 FURTHER READING

Adamy, D.L. EW 101: "A First Course in Electronic Warfare", Norwood, MA, Artech House, Inc., 2001, (ISBN 1-58053-169-5).

Adamy, D.L. EW 102: "A Second Course in Electronic Warfare", Norwood, MA, Artech House, Inc., 2004, (ISBN 1-58053-686-7).

Encyclopedia of Aerospace Engineering. Edited by Richard Blockley and Wei Shyy. John Wiley & Sons, Ltd. ISBN: 978-0-470-75440-5, October 2010. Volume 7, Chapter 376: *Electronic Warfare and Defensive Aids System Design and Development*, by M. Pywell.

Schleher, D.C., "Electronic Warfare in the Information Age", Norwood, MA, Artech House, Inc., 1999, (ISBN 0-89006-526-8).

## Chapter 6 – EW T&E RESOURCES AND FACILITIES

### 6.1 INTRODUCTION

This chapter provides generic descriptions of ground and flight test resources and facilities commonly utilised in the T&E of EW systems and components. EW T&E capability types are introduced and their primary functional categories explained. Distinguishing factors of facilities are discussed. The chapter concludes with a section on the common use of many of the test facility types for EMC and EMI testing of EW and other systems.

Descriptions of known EW and related test facilities in NATO Nations are given in Annex A. Whilst this annex does not fully describe every resource that a project may wish to utilise, it represents a valuable resource for understanding the range of facilities available to meet the goals of a structured test process.

### 6.2 SCOPE OF EW T&E CAPABILITIES

A number of T&E facilities and resources, or ‘capabilities,’ are required to support:

- EW system design, development and performance verification against its specification;
- Government acquisition agency (‘customer’) and military end user acceptance; and
- Operational use of the platform.

There are various definitions of T&E capabilities across NATO Nations and these are typical:

- ‘A Test and Evaluation (T&E) capability is a combination of facilities, equipment, people, skills and methods, which enable the demonstration, measurement and analysis of the performance of a system and the assessment of the results.’ [1]
- ‘The people, assets and processes to undertake evaluation with sufficient accuracy and timeliness to assure provision of through-life military capability.’ [2]

Throughout this Handbook the human aspect of EW T&E capabilities is considered to be implicit. The operation of many of the facilities described in this chapter depends upon a high degree of specialist engineering knowledge and expertise in the Electromagnetics and Systems Engineering domains.

Facilities and equipment are described with reference to terminology used in the first issue of this Handbook and [3], with commentary and examples. The range of facilities is shown in Figure 1-6 and a non-exhaustive list of strengths and limitations of each is given elsewhere. [3]

Test capabilities are frequently categorised by their primary function, as given below:

- Modelling and Simulation (M&S);
- Measurement Facilities (MF);
- System Integration Laboratories (SIL);
- Hardware-In-The-Loop facilities (HITL);
- Installed Systems Test Facilities (ISTF); and
- Open Air Range (OAR).

In many cases, however, these definitions are overly and inappropriately restrictive. For example, large anechoic chambers are generally classified as ISTFs and yet they often provide excellent support in the role of MFs. The following sections explain the role of each of the above categories but are not meant to imply that facilities otherwise defined should not be utilised in a role outside their primary designation.

Test missions by location are summarised in Table 6-1.

**Table 6-1: Test Missions by Facility Type.**

Test Location	Primary Test Mission
SIL/HITL (Digital, RF and Intermediate Frequency)	R&D and concept development. Note: Often need simulation capability enhancement to be able to develop new or 'next generation' EW receiver systems/upgrades
	Requirements definition and system performance modelling
	HITL: Equipment/sub-system development and qualification
	Uninstalled sub-system performance verification (usually over full range of performance)
	Integration with other platform avionics; further development and sub-system performance verification, conducted in SIL
	ESM-ECM performance optimisation vs. specified threat environment
	Evaluation of new/upgraded threats and countermeasures development
	Development, evaluation and clearance of EW upgrades
ISTF (Anechoic Chamber and Other)	Platform-system integration. Further sub-system and avionics system development
	Installed system performance verification, including SUT irradiation with 'war mode' and other signals now allowed to be transmitted in the open air
	Fault/anomaly investigation, isolation and solution confirmation
	Airframe-systems aspects of EW upgrades' development, evaluation and clearance
Open Air Test Site	Free space, far field, illumination of aircraft-installed SUTs for cases where anechoic chamber tests not viable or unacceptably limited, e.g., antenna polar diagrams and ESM/ECM beam-forming measurements (far-field)
	Whole platform EMC tests
	Platform radar cross-section measurements
OAR and Other Flight Test Facilities	Residual installed performance verification tests for aspects not acceptably testable using above locations and methods
	Development and performance verification of aspects not ground-testable, e.g., combinations of tactics, flare/chaff dispensing, on-board RF jamming and towed RF decoys
	Evaluation/optimisation of EW system man-machine interface under flight conditions
In-Service Support – a.k.a. 'Sustainment' (Laboratories and OARs)	Mission Data Validation prior to and during training, operational evaluation and combat
	EW hardware/firmware and algorithmic software performance optimisation
	Post-maintenance and pre-flight check-out
	Evaluation and resolution of operational problems
	EW and countermeasures/tactics effectiveness evaluation/optimisation
	Mission rehearsal and aircrew/operator/maintainer training

An important distinction, especially relevant to RF EW systems, is the difference between ‘un-installed’ and ‘installed’ sensor and system performance. In the former case the sensor is not mounted on the platform, e.g., a stand-alone RWR antenna. In the latter case the sensor is mounted correctly on the platform, i.e., for the above example the RWR antenna would be mounted in a RAM-lined cavity in a fin-tip pod and covered by a radome made of dielectric material. The EM performance difference between the two cases can be large, in particular where the airframe is non-metallic (e.g., Carbon Fibre Composite), and this can result in system-level performance that requires modification to successfully meet the system’s specification. Such modification can be expensive and time-consuming if not detected until the flight test and production phases. This risk can be adequately managed via validated modelling of installed performance of RF sensors, a topic mentioned in the next section ‘Modelling and Simulation’.

**6.3 MODELLING AND SIMULATION**

M&S, which is also known as Modelling, Simulation and Synthetic Environments (MS&SE), is used to:

- Demonstrate system performance for aspects too complex or too expensive to verify by testing.
- Estimate error bounds where test repeatability is difficult or where tests alone would yield unacceptable error bounds.
- Supplement testing by interpolation between sparse data points or to extrapolate from measured data.
- Prove design concepts prior to final testing.

Most M&S undertaken as part of the design verification process is currently performed by equipment suppliers, who provide outcomes as acceptance evidence to the PSI. An area of promise is Computational EM Modelling (CEM), where modern computing power and innovative codes offer useful design optimisation and risk reduction for RF antenna installations on platforms. Table 6-2 indicates typical example M&S tools used in EW Design and Development (D&D) and T&E.

**Table 6-2: Typical M&S Tools Applicable to EW D&D and T&E.**

<b>MODELS (Examples)</b>		<b>MODELLING LEVEL</b>	<b>TYPICAL MOEs</b>	<b>TYPICAL MOPs</b>	<b>VALIDATION</b>
THUNDER	<b>REFINEMENT OF MODELLING ASSUMPTIONS</b>	Campaign	Campaign length	Aircraft availability	Wartime experience
EADSIM		Mission	Attrition levels	Number of encounters	Wartime experience
AWSEM, SAMOCLES		Engagement	Pk reduction factor	Miss distance	Trials data, including live fire
CEESIM/EGA		System	Jam-to-signal requirements, installed sensor coverage	Pulse characteristics, RF communications link success probability	Experimental data, including whole aircraft test
TLM, GTD/UTD		Sub-system and equipment	Impulse response, uninstalled antenna patterns	Circuit voltages, antenna gain, impedance, RF currents and voltages	Above + EM theory, physics textbooks, standard problems, other validated codes

Notable issues with M&S as relevant to EW T&E are:

- Simulation fidelity and model validation, i.e., how faithfully they represent real threats and EW equipments and their performance.
- Modelling of EW antennas, systems and intra-platform cabling is not sufficiently robust to maximise contribution to acceptance.

There is a continuing US and European thrust to move EW T&E toward ground test and M&S. This work, which requires extensive scenario modelling and the increasing use of EW equipment models, offers great promise in reducing not only the expensive flight testing phase, but also overall EW system development and Mission Data validation timescales and costs. There remains, however, doubt that some aspects, e.g., RF and IR jamming and other countermeasure effectiveness, will ever be fully cleared by M&S alone, i.e., without some residual element of flight trials. This is particularly true of simulations involving a 'man in the loop.' While M&S has become quite good at modelling phenomenology, it doesn't generally handle humans very well.

The topic of M&S, as applied to EW T&E, is expanded in Chapter 7.

### 6.4 MEASUREMENT FACILITIES

MFs establish the character of an EW-related system/sub-system or technology. They provide:

- EW and platform antenna pattern descriptions and platform signature data critical for system design and refinement, computer simulation, and EW equipment/system testing in HITLs, SILs and ISTFs.
- Capabilities to explore and evaluate advanced technologies such as those involved with various sensors and multi-spectral signature reduction. These are used to provide data that cannot be modelled adequately. In some cases, for example antenna pattern measurement, they provide data for validation of M&S used in the Verification and Validation (V&V) process.

Measurement facilities generally fall into the sub-categories:

- Antenna characterisation.
- Signatures measurement: RCS, IR, UV, and laser.
- EMC and EMI, on open air test sites and in anechoic chambers.

Platform-level examples of MF types are given in Figure 6-1.



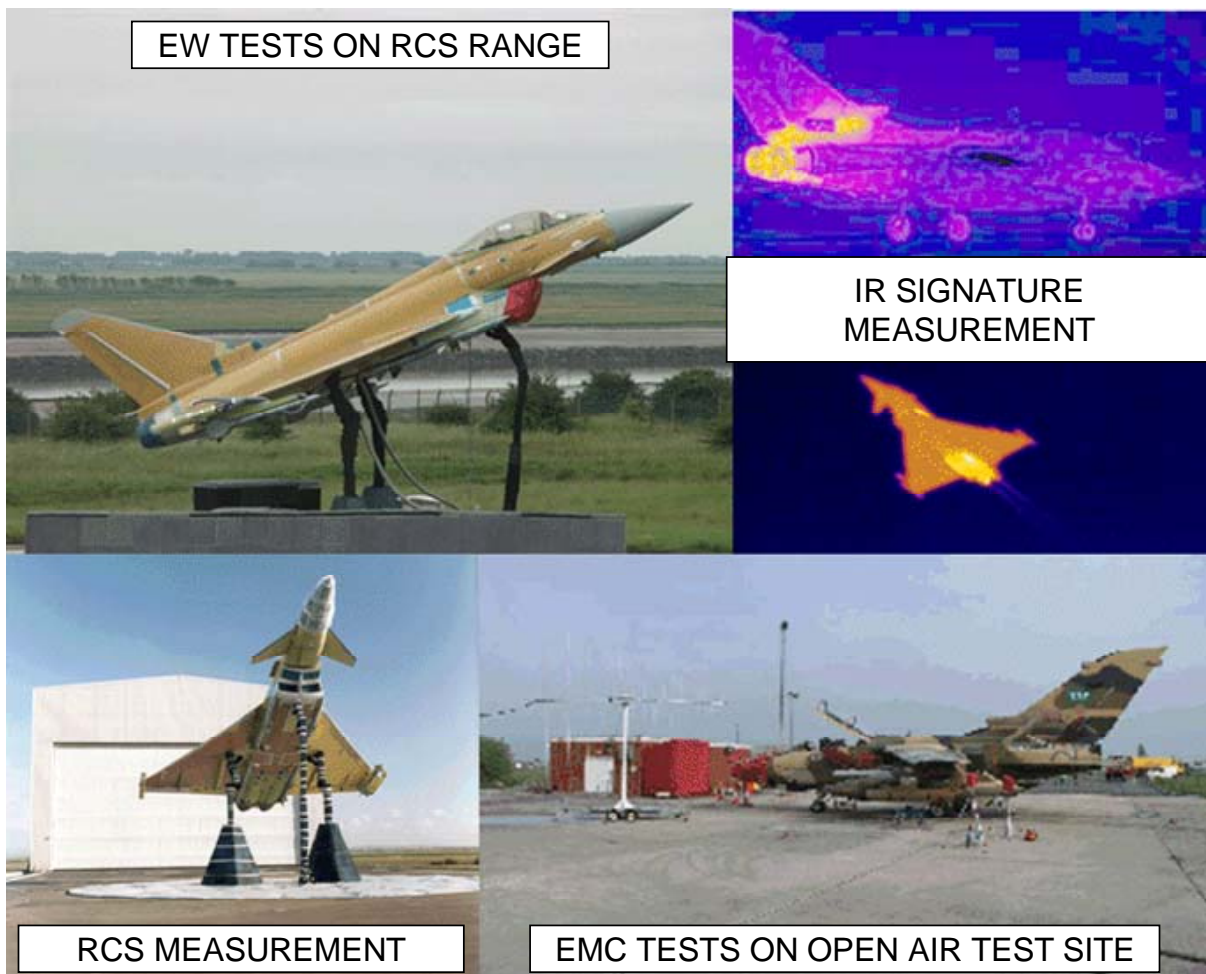

Figure 6-1: Measurement Facility Examples – (© BAE SYSTEMS 2010, All Rights Reserved).

## 6.5 SYSTEM INTEGRATION LABORATORIES

SILs are facilities designed to test the performance and compatibility of components, sub-systems, and systems when integrated with other systems or functions. They are used to evaluate individual hardware and software interactions and, at times, involve the entire weapon system avionics suite. A variety of computer simulations and test equipment are used to generate scenarios and environments to test for functional performance, reliability and safety. SILs are generally weapon system specific and are found in contractor (EW equipment supplier and platform/systems integrator) and Government facilities.

SILs often employ a variety of real-time/near-real-time digital models and computer simulations to generate scenarios and multi-spectral backgrounds. These models are interfaced with brassboard, prototype or actual SUT production hardware and software. SILs are used from the beginning of an EW system’s development through avionics integration and fielding. Moreover, SILs continue to be used throughout an EW system’s operational life to support:

- Investigation and resolution of in-service problems; and
- Testing of hardware and software modifications and updates.

Whilst the term ‘SIL’ is US-originated, equivalents in the UK and elsewhere are:

- Sub-System (SS) Rig, where individual EW equipments are integrated into a sub-system and developed prior to integration with other platform avionics.
- Avionic Integration (AI) or System Integration (SI) Rig, where – prior to release for aircraft use:
  - The EW sub-system is integrated with the rest of the platform’s avionics and other systems; and
  - Those tests of EW sub-system performance required to be conducted by the project’s qualification and verification test plan are executed.

Conventional SILs and SS rigs are usually found at the facilities of EW and DAS equipment supplier’s and Platform and Systems Integrators. AI and SI Rigs are located at Platform and Systems Integrator facilities and, as they mostly have real avionic equipment fitted, are in fact hybrids of the generic SIL and HITL facility categories. EW testing performed in SILs and on SS/AI/SI rigs generally utilise EW/DAS equipments in a laboratory environment on a ‘spread bench,’ as in Figure 6-2, with all other aircraft data supplied via simulations generated by an external control computer. These computers often serve as master test controllers and also provide non-RF data acquisition and analysis, e.g., of data bus traffic.



**Figure 6-2: EW Equipment on Avionics Integration Rig –  
(© BAE SYSTEMS 2010, All Rights Reserved).**

EW Receiver stimulation is performed by RF threat emitter simulators such as the widely used Combat EM Environment Simulator (CEESIM). Characterisation of signals at RF can be executed by the use of various test equipments, e.g., spectrum and pulse domain analysers. However, for optimum measurement, recording and analysis of complex RF jamming waveforms from modern EA systems, EW T&E equipment such as the Signal Measurement System (SMS) is required. CEESIM and SMS<sup>1</sup>, which are shown in Figure 6-3, are but one example of this high performance EW T&E equipment.

<sup>1</sup> CEESIM and SMS are products of Northrop Grumman, Amherst Systems Inc.



**Figure 6-3: RF Threat Emitter Simulator and EA/ECM Signal Measurement System – (BAE SYSTEMS Photograph).**

Once the DAS has reached suitable maturity it is integrated with other sub-systems, e.g., Displays and Controls, on an avionic integration rig. System-level performance verification testing is conducted using the EW equipments once integrated with the other real aircraft equipment on the rig. Once again EW receiver stimulation is performed by a threat simulator but the level of testing is reduced as most of the individual equipment and sub-system performance has already been proven by the earlier verification and qualification phases at the platform/systems integrator and equipment supplier.

All verification tests conducted on these rigs is traceable back to the original customer requirement through the Verification and Validation Requirements Matrix. Integration rigs are continually utilised throughout the platform’s life to prove software and hardware changes and to re-test system fixes prior to release to the aircraft or to the customer.

## 6.6 HARDWARE-IN-THE-LOOP FACILITIES

HITL facilities are ground-based test facilities that provide a controlled and usually secure environment to test EW techniques and hardware against real or simulated threat systems.

- Primary EW HITL facilities contain simulations of hostile weapon system hardware or the actual hostile weapon system hardware. They are used to determine threat system susceptibility and for evaluating the performance and effectiveness of EW systems and countermeasure techniques.
- Some EW HITL facilities contain friendly weapon system hardware. They are used to evaluate and improve the performance of friendly weapon systems in the presence of various hostile and friendly EW activities. These HITL facilities can also be used to test EW systems where the friendly weapon system represents a potential threat technology.

Although SS, AI and SI rigs include, by definition, real hardware-in-the-loop, generally understood HITL facilities are secure (usually screened or anechoic) indoor facilities that enable un-installed testing of EW techniques against simulation of threats or real threat hardware. Whereas sub-system and avionic integration rigs generally do open-loop EW testing, primary HITL facilities have the capability to do



closed-loop testing, where own EW system effectiveness can be assessed and optimised against threat system sensor systems, and the EP of own EW systems and sensors can be assessed against hostile jamming equipment.

Examples of HITLs are shown in Figure 6-4 and Figure 6-5.



**Figure 6-4: EW HITL Facility Example (1): US Navy EC Systems Evaluation Laboratory.**

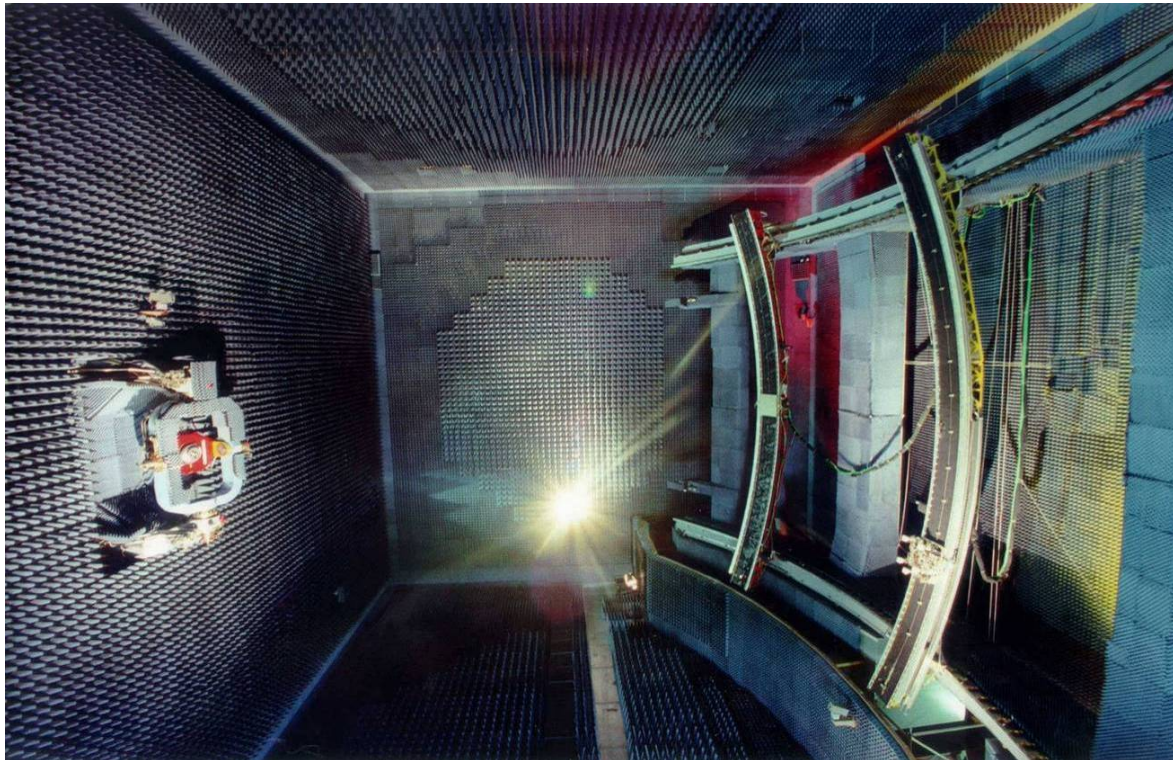

**Figure 6-5: HITL Facility Example (2): UK Dstl Missile Seeker Test Facility – (Defence Science and Test Laboratory Photograph).**

HITL facilities are an important test facility category because they frequently represent the first opportunity to test un-installed system components, for example breadboard, brassboard and pre-production prototypes, in a realistic RF, laser or IR environment. HITL operating environments can provide simulated terrain effects, high signal/threat density and realistic interactive scenarios. Some HITLs offer multi-spectral capability and background noise.

Modern threat representation via closed-loop hybrid threat simulators can be employed for EW effectiveness testing, man-in-the-loop interaction, and Integrated Air Defence System (IADS) networking. Secure (shielded/screened room) operations, test condition repeatability and high capacity data collection and recording are common attributes of the HITL test venue.

HITL testing should be conducted as early in the development process as possible – even if that means using a brassboard configuration. Too often pre-production hardware is developed late in a programme, making identification and correction of problems difficult. EW HITL testing provides repeatable measurements and verification of protection techniques and EW system effectiveness. Results obtained from HITL tests should be compared to predicted results from previous M&S activities. Any differences discovered in this comparison can then be analysed and the appropriate models updated and validated.

## 6.7 INSTALLED SYSTEM TEST FACILITIES

EW ISTFs provide a ground-based capability to evaluate EW systems that are installed on or integrated with host platforms. These test facilities consist of anechoic or shielded chambers in which free-space radiation measurements are made during the simultaneous operation of EW systems and host platform avionics and munitions. Threat signal generators, which are discussed further in Section 6.9, stimulate the EW SUT and its responses are evaluated to provide critical, integrated system performance information.

## EW T&E RESOURCES AND FACILITIES

The purposes of ISTFs are:

- (Primary purpose) Evaluation of integrated avionics systems (e.g., radar, IR, communications, navigation, identification, EW systems or sub-systems, and integrated controls and displays) in installed configurations, to:
  - Test specific functions of complete, full-scale weapon systems; and to
  - Verify specific, platform-level performance against specification.
- Development and evaluation of individual uninstalled EW components, sub-systems or systems in an electromagnetically secure environment.
- Investigation and resolution of any EMI/EMC problems resulting from above.
- Determination of system reactions to EM environments of hostile and/or friendly systems whose signals cannot be radiated in free space on OARs for security reasons.
- Support of flight testing by providing pre-flight checkout and post-flight analysis capabilities (also provided by SILs and HITLs). This ground testing can aid in isolating component, sub-system or system problems not observable in other ground test facilities but crucial to system checkout prior to open-air testing.

Anechoic chamber ISTF cardinal features are indicated in Table 6-3.

**Table 6-3: Cardinal Features of EW Anechoic Chamber Facilities.**

FEATURE	COMMENT
Chamber size	Minimum size around 28 x 18 x 8 m. Largest known chamber is 80 x 76 x 21 m.
Shielding and quiet zones	Usually $\geq 100$ dB over at least 0.5 – 18 GHz. TEMPEST grade. Quiet zones: one or more, dependent on chamber size.
Turntable and crane	Typically in range 30 – 114 tonnes (turntable) and 30 – 40 tonnes (crane).
Below ground room	Most have laboratory, data collection or services room below the chamber.
RF/IR threat simulators	All have RF threat simulators, usually CEESIM, AMES or by EWsT. Some have communications, navigation, IR scene simulators, radar target generator.
ECM response measurement and analysis	All have some capability, from independent equipment (spectrum, vector network, pulse modulation analysers) to comprehensive systems like the SMS.
Data acquisition and simulation	All have some capability, for RF, digital and other signal recording and to provide signals to the platform to enable 'flight' simulation.
Aircraft and other services	<ul style="list-style-type: none"> <li>• Cooling, hydraulics, pressurised air, ground power for aircraft;</li> <li>• Fire suppression, control room, CCTV and video recording;</li> <li>• RAM temperature monitoring; and</li> <li>• Enclosed aircraft preparation area (some).</li> </ul>
Location	Most facilities are adjacent to taxi-way, the flight line or a runway.



ISTFs fall generally into three categories, although some EW test facilities cover more than one:

- **Category I:** End-to-end systems effectiveness testing is performed on installed multi-sensor/multi-spectral EW and other avionics systems under a wide range of realistic threat and operational conditions. These conditions require the appropriate types and numbers of players. Test events range from concept exploration and developmental tests to operational effectiveness testing. Specific tests include EW effectiveness (especially multi-sensor cued countermeasures), platform susceptibility, human factors, EP performance, weapon systems integration performance, ES systems performance, and systems integration testing.
- **Category II:** End-to-end systems integration testing is performed on installed multi-sensor/multi-spectral EW and other avionics systems under conditions necessary to prove system performance. Test events are primarily DT&E oriented with some applications to operational testing. Specific tests include: human factors, EP, avionics systems performance, and systems integration testing.
- **Category III:** Specialised testing is performed such as: RCS measurements, antenna pattern measurements, susceptibility to HPM, EM environmental effects (E3), and limited systems installation and checkout on aircraft, ground vehicles and components.

There are few aircraft-sized EW anechoic chambers in the world. Two examples are shown in Figure 6-6 and Figure 6-7, and others exist within NATO Nations, see Annex A.



**Figure 6-6: ISTF Example 1: Benfield Anechoic Facility – (USAF Photograph).**

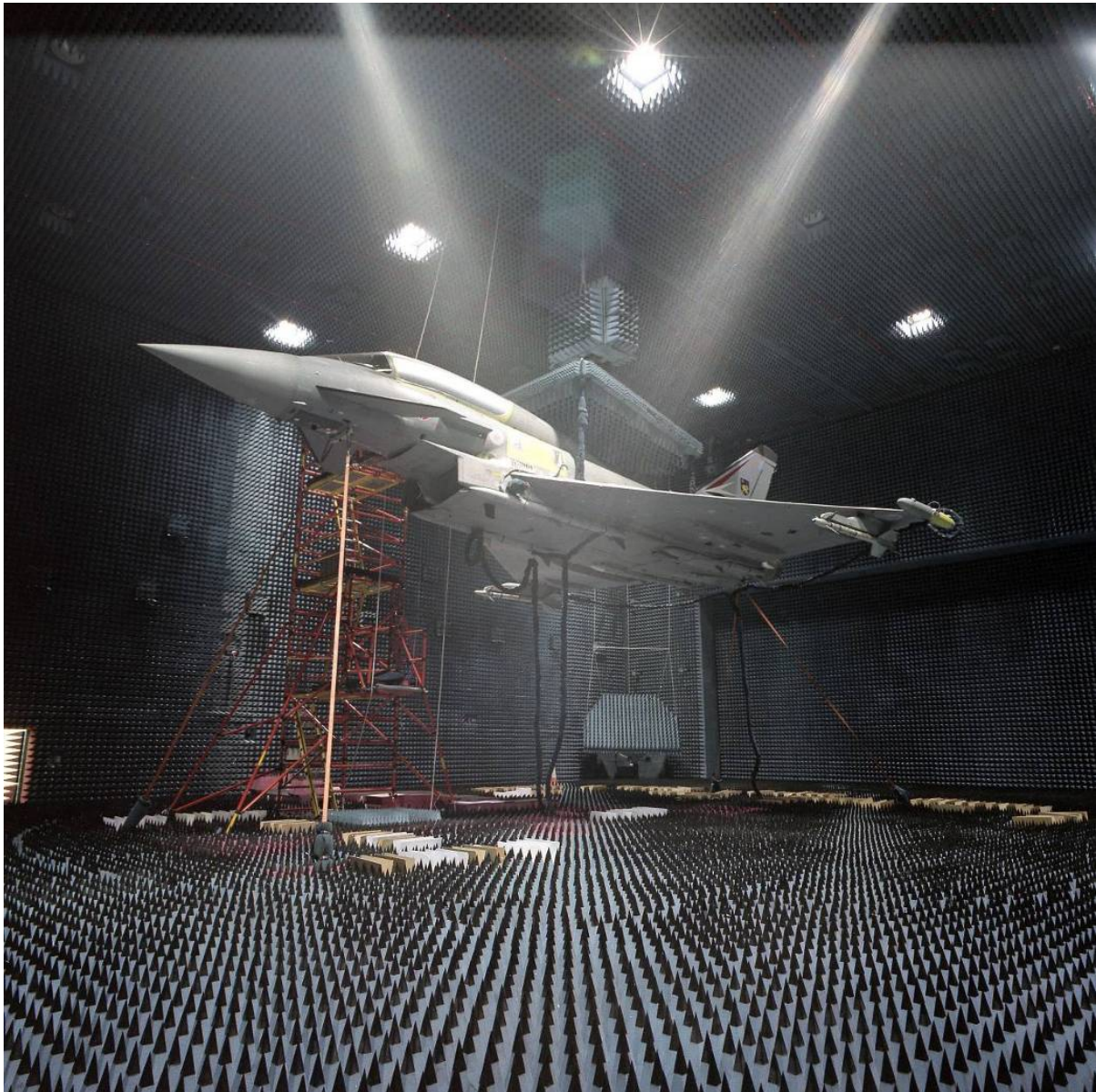

Figure 6-7: ISTF Example 2: EW Test Facility – (© BAE SYSTEMS 2010, All Rights Reserved).

These chambers can also be used:

- For IR/UV/Laser, Lightning Strike, RCS and RF Interoperability (including antenna isolation) testing of installed EW and other RF transmit/receive systems.
- To support evaluation of closed-loop performance against threats in a free-space environment.
- For platform (EW/non-EW) susceptibility testing against HPM and other DE threats.

## 6.8 OPEN AIR RANGES

### 6.8.1 Introduction to OAR Facilities

OARs used for EW and related flight testing are described in this section. Their uses are outlined, and benefits and drawbacks listed. Recognising that flight testing requires a greater level of preparation



and generally costs more if a trial has to be repeated – for whatever reason – than ground-based testing, the topic of ‘Flight Test Planning, Execution and Operations’ is covered separately in Chapter 8.

The increasing complexity of modern avionics and EW systems, along with the growing cost of aircraft operations, has driven most test organisations to reduce the use of OAR testing wherever possible. The extensive capabilities of ground-based test facilities, increased effectiveness of M&S, and improved analytical processes discussed in this Handbook continue to enable this reduced reliance on OARs.

Nevertheless, the OAR remains an important component of the EW system testers’ arsenal:

- EW T&E on these ranges is widely agreed to be the next best thing to war-fighting as this is the only ‘facility’ which provides a wholly realistic flight environment, including multi-spectral background, clutter, and noise.
- It is at the OAR and only the OAR where all elements of the EW system’s operating environment can be accurately and simultaneously exposed to the testers’ scrutiny.

Both DT&E and OT&E are conducted in the OAR environment. All known OARs used for EW T&E are owned and operated by the military, some with civilian contractor support. Most have a combination of multiple real threat systems, manned/un-manned high fidelity threat simulators (‘emulators’ or ‘surrogates’) and other (lower fidelity) simulators.

Figure 6-8 shows a typical OAR used for EW T&E, showing threat simulators.



**Figure 6-8: Typical OAR Used for EW T&E – China Lake Electronic Combat Range – (NAVAIR Ranges Photograph).**

### 6.8.2 OAR Description

OARs are used to support some or all of the following:

- EW system evaluation (DT&E/OT&E and System/Platform Acceptance), in particular of EW systems that cannot be realistically ground-tested, e.g., chaff, flares, towed/expendable/air-launch decoys.
- Initial, advanced and combat readiness training.
- Single and multi-platform force preparation and mission rehearsal. Aircrews can practice manoeuvres and tactics against a variety of threats and targets that they face in combat operations.
- Tactics and countermeasures development and optimisation.
- Development of and input to Concepts Of Operation (CONOPS), in the case of new or upgraded threats or EW systems.
- Research, Development and Engineering in support of new and upgraded EW systems.

OARs focused on EW testing are populated with high fidelity threat simulators in addition to basic range instrumentation. A typical OAR threat simulator is shown in Figure 6-9.



**Figure 6-9: Typical Range Threat Simulator – Joint Threat Emitter (JTE) –  
(© Northrop Grumman Amherst Systems Inc.).**

Some OARs also include real threat systems, both own-side/friendly and opponent. Examples are shown in Figure 6-10.



Figure 6-10: Examples of Actual Threat Systems used on OAR – (China Lake Range – Naval Air Warfare Center Weapons Division Photographs).

## **EW T&E RESOURCES AND FACILITIES**

---

To be useful for most test conditions, these threat simulators are instrumented to establish a record of EW system effects on the threat. This instrumentation must be carefully planned prior to flight testing commencement to ensure that operating modes, pointing angles, receiver and/or transmitter performance, and signal processing features are accurately archived for post-test analysis of EW system performance. In some cases, additional emitter-only threat simulators (a.k.a. signal sources) are provided to create the high signal density characterising typical operational EW environments. These simulators can also be useful for some airborne integration testing where a low fidelity signal is adequate to stimulate the receiver.

OARs vary considerably in the quantity, quality, and flexibility of their threat simulation and other capabilities. The tester must establish precise test objectives and evaluation procedures prior to the selection of an OAR to ensure that these high-cost tests generate meaningful results.

OARs used for EW T&E have some or all of the features indicated in Table 6-4.



**Table 6-4: General Features of OARs Used for EW T&E.**

<b>Capability</b>	<b>Features</b>
<p>Range control and instrumentation</p>	<ul style="list-style-type: none"> <li>• Time space positioning information:               <ul style="list-style-type: none"> <li>• Air Combat Manoeuvring Instrumentation (ACMI) pods</li> <li>• GPS with datalink</li> <li>• Telemetry reception</li> <li>• Range secondary, search/acquisition and tracking/TWS radars</li> <li>• Transponders</li> <li>• Electro-optical (Visual, IR)</li> <li>• Laser range finders (eye-safe)</li> </ul> </li> <li>• Airspace and exercise/test control capabilities:               <ul style="list-style-type: none"> <li>• Interfaces to C2, air traffic control, weapon systems</li> <li>• Audio and visual recording and display/playback</li> <li>• Real-time ‘kill’ notification</li> </ul> </li> <li>• Atmospheric measurement facilities:               <ul style="list-style-type: none"> <li>• Land/maritime – air temperature, humidity, wind, sea state</li> <li>• Visibility (optical, UV, IR)</li> </ul> </li> <li>• Terrain:               <ul style="list-style-type: none"> <li>• Realism (surface characteristics, foliage, obscuration)</li> <li>• Ability to use chaff, flares and other expendables</li> <li>• Ability to use active RF and EO jamming</li> </ul> </li> </ul>
<p>Programmable emitter simulators and emulators</p> <ul style="list-style-type: none"> <li>• Fixed (manned/unmanned)</li> <li>• Mobile</li> <li>• Relocatable</li> <li>• Open loop</li> <li>• Closed loop (reactive)</li> </ul>	<ul style="list-style-type: none"> <li>• Radar (search, track, surveillance)</li> <li>• Communications (analogue, digital, fixed frequency, spread spectrum)</li> <li>• Visual signature (shape, smoke trail, etc.)</li> <li>• Signatures: IRS, UVS, acoustic signature</li> <li>• IR/UV stimulators, which also help pilots become more familiar with the manoeuvres that will optimise DIRCM/flare deployment and effectiveness</li> <li>• Human-In-The-Loop, automatic and remotely controllable</li> <li>• Missile launch indication</li> </ul>
<p>Signature measurement</p>	<ul style="list-style-type: none"> <li>• RCS (platform, towed/expendable decoys, chaff)</li> <li>• Electro-optical (Visual, IR, UV)</li> <li>• RF emissions (radios/radars, EA, communications, navigation systems)</li> <li>• Acoustic</li> </ul>
<p>Databases</p>	<ul style="list-style-type: none"> <li>• EW Systems</li> <li>• Operational procedures</li> <li>• EW emitter parametrics</li> <li>• Signatures (RCS/IRS/UVS, RF emissions, acoustic)</li> <li>• Terrain (local and target)</li> </ul>

### **6.8.3 OAR Uses**

#### **6.8.3.1 Primary Purpose**

The primary purpose of OAR EW testing is to evaluate the system under real-world representative environment and operating conditions. Primary tasks are:

- DT&E flying – The final stage of acceptance testing – covers:
  - Verification that EW system performance characterised in earlier test events is representative of performance in the intended operational environment. Results of OAR tests are compared to results obtained in MFs, SILs, HITLs, and ISTFs to arrive at a complete and consistent evaluation of system performance and predicted effectiveness.
  - Final performance verification undertaken prior to customer delivery. This testing not only examines system performance when installed in the airframe, but also looks at safety in terms of, for example, safe separation of flares, chaff and towed decoys.
- OT&E flying – To validate system operational performance/effectiveness at a high level of confidence.
- Gaining an early understanding of operational features such as supportability, utility, and reliability.

In addition to the above, OARs can be used throughout the test process to establish a consistent threat baseline, act in the role of a HITL or ISTF, or provide initial ‘seed’ data for requirements generation. In these roles the OAR facility descriptor is sub-categorised into test ranges and airborne testbeds, which are described in the remainder of Chapter 6.

#### **6.8.3.2 HITL Testing on the OAR**

Since EW OARs typically possess a variety of threat simulation systems, they may be able to support HITL testing. While the physical configuration of a range differs considerably from the general notion of a HITL facility, see Section 6.6, the equipment available on the OAR frequently meets the tester’s needs for such tests. The SUT may be located in some form of mobile laboratory (a van or trailer is common) and located near the victim hardware against which it is to be evaluated. This approach can yield advantages:

- Duplication of expensive threat simulators at multiple locations is unnecessary.
- Since the same threat hardware is employed in both the HITL and OAR test phases, an important variable is removed.
- An economy of scale is realised; overhead costs are shared between both OAR and HITL tests, and utilisation rates are improved.

#### **6.8.3.3 Correlation of Test Resources**

One of the most troublesome and difficult parts of the EW test process is the correlation of data between different test stages. For instance, if results from a HITL test disagree with results obtained during ISTF testing, the test engineers must understand the cause of the varying observations. The OAR is often viewed as the most authoritative source of test data and so correlation of all subordinate test venues to the OAR is desirable. However, such correlation is often difficult as an OAR will only have one instance of a threat that may or may not represent the combat population. As well as simulating multiple instances of emitters, SILs, HITLs and ISTFs also allow excursions in frequency, PRI, etc., not available on an OAR.

If properly structured, flight testing can be used to validate/calibrate ground test facilities and models. EW components, sub-systems, systems, and entire avionics suites can be installed in either a ground or airborne testbed or in the intended operational platform and tested on OARs.

Real-world phenomena such as terrain effects, multi-path propagation, and EMI from commercial systems (television and radio broadcasts, microwave transmissions, etc.) will be encountered during OAR testing.

The correlation process requires an understanding of each of these effects along with the behaviour of the SUT and any threat or victim systems in play. While such an analysis is technically challenging, time consuming, and costly, it usually leads to a consistent evaluation of the EW system.

#### **6.8.3.4 Airborne Testbeds and Flying Laboratories**

These flying resources are especially useful in the development of EW and sensor systems. Two sub-categories exist, those which:

- Serve as flying laboratories to carry the SUT, test support personnel, and instrumentation into the test environment.
- Include airframe or pod-mounted systems used to simulate an adversary weapon system, armament, or EW capability.

The flying laboratory has become increasingly important as EW/avionics systems have grown in cost and complexity. It offers an in-flight environment to testers and development engineers alike to make first-hand observations of system performance under realistic conditions. When assessing the flying laboratory facility for its applicability to a specific test project, one must consider the space available for installing antennas and sensor apertures, other components of the SUT, and instrumentation sufficient to accomplish the desired testing. Access to the SUT or the ability to modify software in flight may be an important consideration for some tests. In addition, the testbed platform capability to provide adequate power and cooling will always be a factor for consideration.

Airborne testbeds and laboratories range from small aircraft with pod-mounted components or systems, see Figure 6-11, to large aircraft designed for spread-bench installation and testing of EW and avionics systems. They permit flight testing of components, sub-systems, systems, or functions of EW or avionics suites in early development, often before the availability of prototype or production hardware.



**Figure 6-11: Typical Airborne Testbed – (© BAE SYSTEMS 2010, All Rights Reserved).**

### 6.8.3.5 Threat Simulation Testbeds

Threat systems and components may be hosted on range support aircraft to support flight tests and gather data to be used at other test venues. Due to the expense and operational difficulty associated with live fire tests of threat missiles against friendly platforms to evaluate end-game performance of EW techniques, “captive carry” missile seekers are often utilised. In this process a host aircraft carries aloft an actual or simulated threat missile seeker. The pilot follows, to the greatest extent possible, the flight profile commanded by the missile seeker. While very useful, this is a limitation of the capability. It doesn’t follow actual missile guidance and closure rates are not realistic, so analysts need to take this into account.

The actual seeker may be mounted within the host airframe or in a pod to be carried on the wing of the host. This technique permits engineers to access the effectiveness of various EW techniques as the missile closes to close proximity of the target. In some applications multiple seekers may be carried simultaneously so that the net effects of ECM can be compared.

### 6.8.3.6 Tactics Development and Training

There will always be a need for some flight evaluation of EW systems, especially for development of tactics and training in support of operations and exercises. Ranges like the EW Training Facility at RAF Spadeadam (GBR), Electronic Combat Range at China Lake (USA) and Multi-national Aircrew Electronic Warfare Training Facility (MAEWTF) Polygone (USA/FRA/DEU), and the capabilities of NATO’s Joint EW Core Staff, see Figure 6-12, are essential to optimising survivability and mission success probability.



Figure 6-12: NATO JEWCS Training/T&E Capabilities – (NATO JEWCS Photograph).

Some EW OARs can provide the capability for tactics development and training in operationally realistic scenarios. Aircrews can experience a dynamic and complex threat environment, including movable threats, whilst operating with other force components: Time Sensitive Targeting, Close Air Support, Forward Air Control, and Intelligence, Surveillance, Target Acquisition and Reconnaissance.

#### **6.8.4 Benefits and Drawbacks of EW T&E on OARs**

Key benefits:

- The full range of tactics and countermeasures against given threats can be explored, including dynamic closed-loop effectiveness testing against threats.
- OARs provide real-world phenomena that cannot be repeated or is difficult to repeat in the laboratory or chamber environment. These include terrain, inter-platform multi-path, chaff dispersion and realistic civilian communications and radar environments.
- OARs can be used to gather data for validating threat simulators and M&S tools and processes.

Drawbacks:

- Flight testing is expensive, especially when compared to chamber and laboratory testing.
- Range threat densities and mixes are usually very limited compared to war, due to the high through life cycle cost of real threats, emulators and simulators.
- Threat scenario flexibility is limited (governed by the range location) and results are not easily repeatable.
- Flight testing is logistically difficult, especially for NATO Nations using out-of country ranges.
- Range time slots for DT&E are usually limited due to great demand by military users for training and OT&E. This underscores the importance of gaining maximum confidence from ground testing and M&S/SE. The drawback is, in fact, usually double when a test fails: the flight has to be repeated after problem investigation and resolution and, as important, the valuable range slot has been denied to another user.

Notwithstanding aspects that can only be adequately tested in flight, chambers and laboratories are much better capabilities from an optimised T&E cost-effectiveness viewpoint than OARs for (especially RF) EW testing as follows:

- Cheaper and logistically easier than flight testing, when overall trials' costs are considered.
- Operationally representative threat densities, mixes and scenarios are achievable, albeit currently with lower simulation fidelity than real threats (noting that chambers can do some SUT tests using real threats when they are made available).
- Scientifically high test repeatability, due to tightly controlled test environment, especially in anechoic chambers.

As T&E capabilities and processes are developed, it is likely that the balance will continue to shift from EW flight testing further in favour of more ground testing and M&S. In this way residual flight testing can be more focused and have a much higher success probability, as many test points will then be confirmatory rather than experimental in nature.

#### **6.8.5 Other EW T&E Resources for OAR Testing Support**

Although not strictly flight testing or part of OARs, flight line test sets and similar EW T&E equipment are a very useful T&E resource, especially when performing installed system integration testing on an aircraft. Often, for this type of test, only a limited T&E capability is necessary – a device capable of generating a response in a SUT so that its basic integration with other systems can be evaluated. Figure 6-13 provides some examples of this type of equipment.



**EW T&E RESOURCES AND FACILITIES**

**JSECT:** AN/USM-670 Joint Service Electronic Combat Systems Tester: Platform-independent EW system and cable tester.



(© 2010 AAI Corporation. All rights reserved)

**PLM-4:** USAF flight line threat generator (a.k.a. ‘Squirt box’).



(USAF photograph)

**Mallina:** UV missile launch simulator for Missile Warners.



(© ESL Defence Limited 2009)

**ACT:** Aviation Crew Trainer, IR MANPADS trainer, with RF emitter optional capability.



(© 2011 Northrop Grumman Amherst Systems Inc.)

**Figure 6-13: Examples of Flight Line Testers and Other Equipment for EW T&E.**

They are usually limited to confirmatory checks, rather than providing full performance verification, and are designed to increase flight test/trial success probability. A number of them are also used for training and tactics development, e.g., ground-based UV sources for Missile Warner detection and DIRCM/flare dispensing optimisation. Such test sets, dependent upon capability, can also be utilised for system testing but can be limited when compared to, for example, chamber- and laboratory-based threat simulators.



## 6.9 DISTINGUISHING FACTORS OF TEST FACILITIES

While the primary designation of a test facility can be used to describe it at a generic level, the test engineer must consider a number of other characteristics to determine the applicability of the facility to a particular test effort. The test plan should define the approximate characteristics that must be simulated or measured during each phase of testing. This is the starting point for selection of test resources.

As preliminary choices for test resources are made, more specific detail can be included in the test plan and then some refinement of actual tests to be accomplished at each stage or facility is possible. This iterative approach to define, refine and finally confirm test resource utilisation should be expected for most test activities. Some of the key parameters that distinguish one facility from another are discussed in the following paragraphs.

### 6.9.1 Number and Fidelity of Players

The total quantity of friendly and adversary players that can be synthesised during testing is important in assessing SUT performance in conditions of varying density and complexity. The ability of EW T&E facilities described in Sections 6.3 through 6.8 to provide numbers and types of platforms and emitters, especially at RF, is varied and is a key factor in determining the technically best and most cost-effective place to conduct a given test. Table 6-5 indicates player fidelity available on each facility type. Moving from ‘Simulated’ toward ‘Real’ implies increasing fidelity, complexity and cost; whilst at the same time increasing ease of test and reality of training.

**Table 6-5: Player Fidelity vs. Test Facility Type.**

PLAYER FIDELITY		TEST FACILITY TYPE					
		M&S	MF	HITL	SIL	ISTF	OAR
<b>REAL:</b> Real, fully functioning assets, e.g., aircraft, ships, land vehicles and SAMs.	SUT	No	Yes	Yes	Yes	Yes	Yes
	Platforms	No	Yes	No	No	Yes	Yes
	Threat Systems	No	No	Yes	No	Yes	Not Usually
<b>EMULATED:</b> Physical and/or digital models providing real stimulus at SUT. May include part-real platforms/threats.	SUT	Yes	N/A	N/A	N/A	N/A	N/A
	Platforms	Yes	N/A	Yes	Yes	No	No
	Threat Systems	Yes	N/A	Yes	Yes	Yes	Yes
<b>SIMULATED:</b> Digital models of players in ‘virtual’ scenarios. Actual sensor stimulus generated for non-M&S.	SUT	Yes	N/A	N/A	N/A	N/A	N/A
	Platforms	Yes	N/A	Yes	Yes	Yes	Yes
	Threat Systems	Yes	N/A	Yes	Yes	Yes	Yes

Traditionally, in most cases, simulated players were sub-divided into two categories; foreground and background. The foreground players can usually be precisely controlled to follow specific flight paths and have well-defined physical characteristics. Background players were generally of lower fidelity and simply added to the overall scenario density. Nowadays, many-channel RF simulators can produce up to thousands of fully complex emitters at the digital level. Inevitably, the ability to generate these emitters at RF is limited by the number of channels available, the channel pooling capability and the SUT’s sensitivity to dropped pulses. This has enabled significantly better representations of operational RF emitter environments than before. Pre-defined scenarios and man-in-the-loop scenarios can be run,

with pre-scripted threat engagements or ones based on weapon system engagement models within the simulator. It is now also possible to include civilian radar emitters, RF jammers and ‘third party tracking’, where the emitter tracks another platform in the scenario and the SUT rarely or never sees its main beam.

**6.9.2 Fidelity of Digital Models**

Digital models of threats, geography, meteorology, phenomenology and the players in a test scenario can differ greatly in their availability, accuracy and capability to interact with the System Under Test (SUT). Some models may permit interaction with a human operator (operator in the loop); others may be able to accurately account for the effects of ECM/EA (‘EC capable’).

Some models are predicated on extensive analysis and reverse engineering of the threats they represent while others are based on limited intelligence collection. The pedigree of a model is frequently defined through a rigorous process of VV&A. The tester must research the attributes of the models to be used and fully appreciate the implications of various levels of fidelity on the results, conclusions, and recommendations to be reported out of the test process.

Section 5 of [4] contains a useful discussion of this important topic under the heading ‘Simulation Fidelity – the quest for affordable emulation’. A key question regarding simulation fidelity is ‘How good is enough?’ for a specific SUT test, since increasing fidelity generally means increasing whole life cost. This thorny question is discussed in a number of references and the nub of the question is depicted in Figure 6-14. [4],[5]

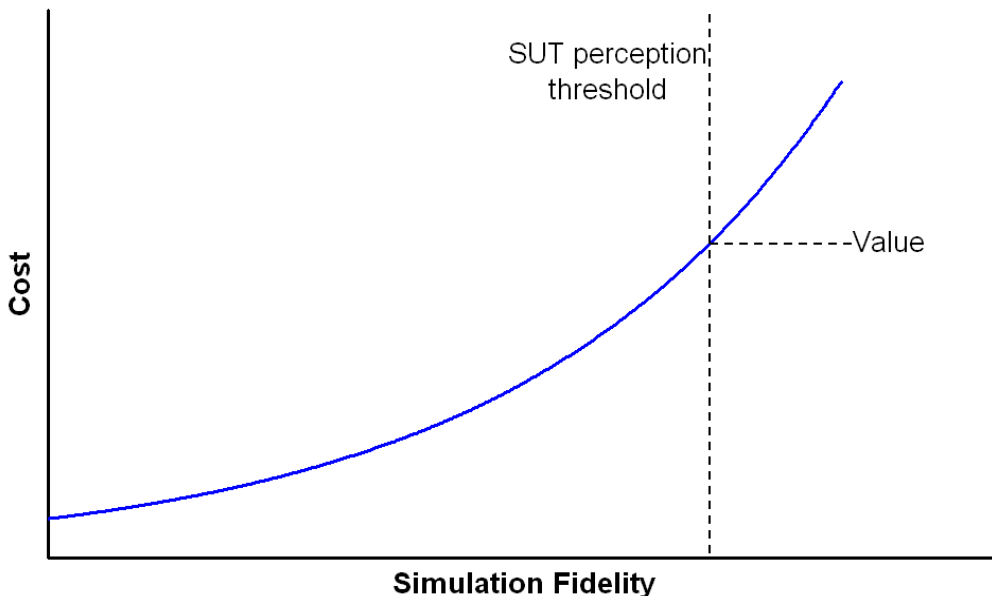

Figure 6-14: Simulation Fidelity – How Good is Enough?

**6.9.3 Time, Space and Frequency Resolution and Accuracy**

From the test planning process the tester should determine what analysis will eventually be accomplished. Data acquired at each stage of testing must be sufficient to support the specified analysis. Data analysis will set the baseline for both the accuracy and resolution of data to be used in evaluation of the SUT. The tester must understand the effects of data inaccuracies and errors in time, space or frequency (and combinations thereof) on the evaluation of system performance and effectiveness.

### 6.9.4 Signal/Scene Generation

A dominant factor in the selection of test facilities will be the capability to generate the various signals (RF) and scenes (IR/UV) to which the SUT must be exposed. This characteristic includes the frequency range, amplitude range and dynamics of the objects included in the signal/scene set. Of equal importance to the generation of signals and scenes is the manner in which these characteristics are imposed upon the SUT. In some cases they must be injected into the SUT electronics while other facilities can actually radiate the signals or scenes through free space. The tester must also consider the importance of the scenario generation process to respond to the SUT (closed loop versus open loop). The importance of these distinctions will be dependent on specific test objectives and SUT architecture.

RF threat simulators and ECM response measurement and analysis systems, see Figure 6-3, are key test facility equipment. The quantity of RF channels in threat simulators, a significant cost driver, governs their ability to generate complex threat environments. Figure 6-15 reports a survey of the quantity of RF channels per simulator. Chamber installations tend to have simulators with at least eight RF channels.

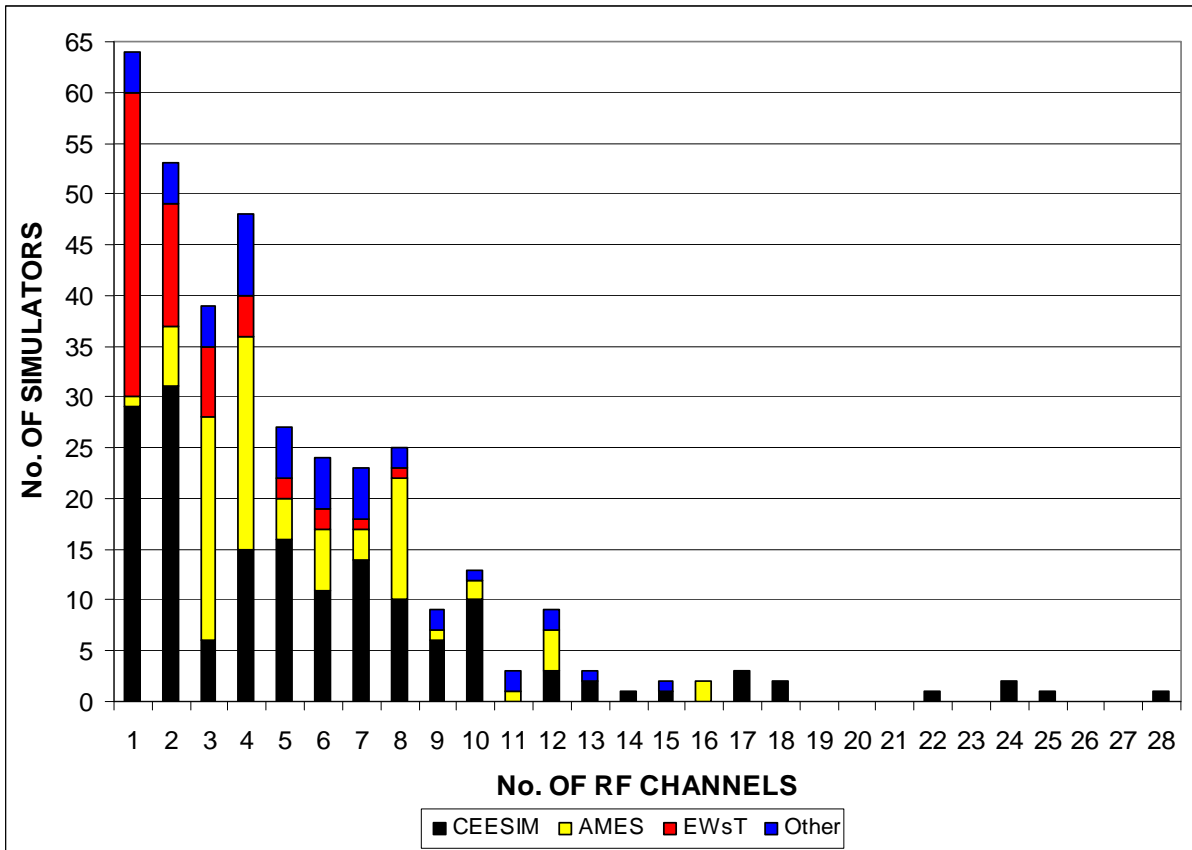

Figure 6-15: Quantity of RF Channels per Simulator – (From [6], with Permission).

Electro-optic/IR/UV scene simulation, by sensor, system or platform irradiation, or by post-sensor ‘direct injection’ into the SUT, is particularly challenging in the ground test environment. The advent of systems like the Real-time Infrared Scene Simulator (RISS), see Figure 6-16, has provided a step up in laboratory and chamber T&E capability – the ability to provide coordinated multi-spectral threat scenarios. [7] Such capabilities are becoming increasingly important as EW systems move toward full integration, where it may not be possible to adequately ground test the SUT in the traditional way of spectral segment by spectral segment (i.e., Radios/Radars, IR, UV, laser separately).



Figure 6-16: Example of RISS Hardware – (© Northrop Grumman Amherst Systems Inc. 2009).

### 6.9.5 Instrumentation

The ability to accurately capture the activities of both the test facility and the SUT during a test is primarily established by the type and amount of test instrumentation available. An important, but often overlooked concern in this area is the undesired (and sometimes unknown) effects that the facility and its instrumentation may have on the test environment. The instrumentation must accurately measure and record what the SUT was actually exposed to, not just what was intended.

### 6.9.6 Security

Some tests may require that all test conditions and resulting data be protected at very high security levels. This requirement may impose special constraints on how test systems are controlled and interconnected or how data acquired during a test is processed. For software intensive facilities, security must be designed into the software, not accommodated as an afterthought. The highest level of RF/EO/IR/UV security control is offered by TEMPEST-grade aircraft-sized anechoic chambers.

### 6.9.7 SUT Support

This characteristic defines what power, cooling, and physical positioning capabilities are offered by the test facility. It is of primary importance in ISTFs and MFs, and Table 6-3 indicates general features required. Annex A contains specific details of support capabilities offered by available test facilities.

## 6.10 ELECTROMAGNETIC COMPATIBILITY AND INTERFERENCE

As mentioned earlier in this section, ISTFs are often used to conduct EMC/EMI tests. While these tests are not uniquely associated with EW systems, they are crucial to overall weapons system performance.



Numerous specifications and standards dictate system design characteristics that must be met to minimise EMI and maximise EMC. To the EW engineer, EMI can result in a vulnerability that can be exploited by EA systems. On the other hand, the EW engineer must be concerned with the compatibility of the EW systems with other aircraft avionics. For instance, if the aircraft jammer produces false alarms on the pilot's RWR, it would be problematic in combat use. The following paragraphs will discuss in some detail some of the types of EMC/EMI tests EW testers should be familiar with.

### 6.10.1 EMC/EMI Tests

There are four types of EMC/EMI tests: Radiated Susceptibility (RS), Radiated Emissions (RE), Conducted Susceptibility (CS), and Conducted Emissions (CE). During RS testing a test antenna is used to transmit RF at the SUT to see if it is susceptible (whether it can be caused to malfunction or break), whereas in RE testing measurement antennas are used to determine whether RF emanations from the SUT exceed specified levels. RS and RE tests require a shielded room/anechoic chamber. CS and CE tests are usually performed in a shielded room but can be performed in SILs. During CS testing a current probe or similar direct coupling device is used to couple RF current down cabling into the SUT. EM energy is injected to characterise the susceptibility of the SUT to this injected RF current. Similarly, the probe or direct connection can be connected to a receiver or laboratory test equipment to measure cable-borne RF currents from the SUT. Figure 6-17 shows avionics equipment undergoing EMC qualification testing.



**Figure 6-17: Typical EMC Testing of EW Equipment –  
(© BAE Systems 2003, All Rights Reserved).**

During emissions testing all modes of the SUT should be exercised. During susceptibility tests, an end-to-end test in addition to exercising BIT should be performed to verify proper operation. For receiver testing



the input should be a mixture of various power levels within the receiver band-pass, the lowest power level being used for the highest priority signals. The goal is to determine if the receiver can process weak input RF signals while interference is being picked up by control and power lines, etc. The emission tests are non-destructive, whereas the susceptibility series of tests always run the risk of causing damage if systems are not properly designed.

During development tests, it is advisable to perform equipment and sub-system EMC/EMI testing as early in the programme as possible. Quite often EMC/EMI tests are delayed to the end because problems in other disciplines are still being resolved. The rationale is to wait and do EMC/EMI tests on the system in its final configuration. EMC/EMI tests are expensive, and there are logistic problems in moving the systems and its interfacing equipment to the EMC laboratory. But if EMC/EMI failures are detected early, they can be fixed at relatively low cost and little impact to the system schedule.

### **6.10.2 Platform-Level EMC Testing**

EMC testing at the platform level can be further defined as Intra-system and Inter-system EMC tests. Intra-system EMC tests are used to evaluate the SUT's ability to operate in the presence of other systems installed on the platform. Inter-system tests are used to evaluate the SUT's ability to operate in the presence of external RF emitters representative of the intended operational environment.

#### **6.10.2.1 Intra-System EMC Tests**

Generally, the SUT's performance will be monitored while each other platform system is cycled through its modes, then all systems are operated together. These tests are generally conducted on an open-air test site (a type of MF), anechoic ISTF or hangar, dependent on the test in question. If the SUT exhibits adverse response to the operation of other onboard systems or vice versa, then an EMC issue has been identified. ISTFs and MFs have an important part to play in aiding testers investigate and isolate such problems, and develop and clear solutions. Whenever the systems being tested include explosive devices such as squibs for chaff and flares, adequate safety margins must be considered. Typical margins for systems containing explosives are ca. 20 dB. A 6 dB safety margin for non-explosive systems is common.

#### **6.10.2.2 Inter-System EMC Tests**

For these tests the SUT performance is monitored while the platform is radiated with RF at power levels and modulations of radar and other RF signals that may be present in the intended operational EM environment. Staircase levels of RF field strengths (power densities) and system performance are usually part of the SUT specification and test programme. Full system performance in the required operational RF environment can be arrived at by a combination of full-threat testing and extrapolation by analysis. An important inter-system EMC test for the EW T&E community concerns formation flying, where each aircraft's radar and RF jamming systems can pose a significant interference hazard to the very sensitive EW and radar receivers on the other platforms in the formation. Figure 6-18 shows a typical MF-based test used to confirm specified performance for formation flying conditions.



**Figure 6-18: Typical Platform-Level Inter-System EMC Test –  
(© BAE SYSTEMS 2010, All Rights Reserved).**

## 6.11 REFERENCES

- [1] UK Defence Industrial Strategy. Defence White Paper, CM 6697, 15 December 2005.
- [2] MoD Defence Test and Evaluation Strategy. 22 July 2008.
- [3] EW Test and Evaluation Process – Direction and Methodology for EW Testing. Air Force Manual 99-112. 27 March 1995.
- [4] Pywell, M. Developments in RF simulator technology – approaching the affordable fidelity limit. *The Aerospace Journal*, Vol. 111, No. 1123, September 2007.
- [5] Anderson, R.B., Bieling, R., Strombo, G., Hunt, D. and Brown, F. Threat correlation to ground test stimulators at the Benefield Anechoic Facility (BAF). US Air Force T&E Days, 6-8 December 2005, Nashville, Tennessee. AIAA 2005-7659.
- [6] Pywell, M. and Midgely-Davies, M. Improved Test Capabilities for Cost-effective Performance Evaluation of Airborne Electronic Warfare Systems. *The Aeronautical Journal*, September 2010, Volume 114, No. 1158, pp. 527-547.
- [7] Jacobs, S.E., Palumbo, P.W., Henderson, S.M. and Makar, R. Installation of an IR/UV Stimulation Test System into the CECOM ISTF. *Technologies for Synthetic Environments: Hardware-in-the-Loop Testing VIII*. Proc. SPIE, Vol. 5092 (2003).

## 6.12 FURTHER READING

Wallace, Wg. Cdr. P.J., (RAF) Modernizing EW Ranges. *Journal of Electronic Defense*, Vol. 33, No. 3. March 2010.

Encyclopedia of Aerospace Engineering. Edited by Richard Blockley and Wei Shyy. John Wiley & Sons, Ltd. ISBN: 978-0-470-75440-5, October 2010. Volume 7, Chapter 376: Electronic Warfare and Defensive Aids System Design and Development, by M. Pywell.

Pywell, M., Alonze, P.M., Hurricks, M.E. and Wellings, I.G. The new Enigma – Increased Survivability with Reduced Cost? NATO RTO SCIP Symp. on 'Flight in a Hostile Environment' (1999). Conf. Proc. RTO-MP-47, AC/323(SCI)TP/22.

## Chapter 7 – MODELLING AND SIMULATION FOR EW T&E

### 7.1 INTRODUCTION

This chapter provides an overview of M&S and emphasises its value to the EW T&E process. A rigorous yet pragmatic approach to its use is necessary to optimise benefits to platform projects. Reference is also made to the topic of threat simulation, a key capability that supports the EW T&E process.

M&S is the representation of ‘reality’ through the use of models and simulations, nowadays mostly hosted on non-specialised PCs. Testing of military systems can be considered to be a ‘simulation’ of their operational use, including combat. Figure 7-1 indicates this scope in the context of M&S – the electromagnetic battlespace, as can be generated by RF and EO/IR threat simulators for EW T&E.

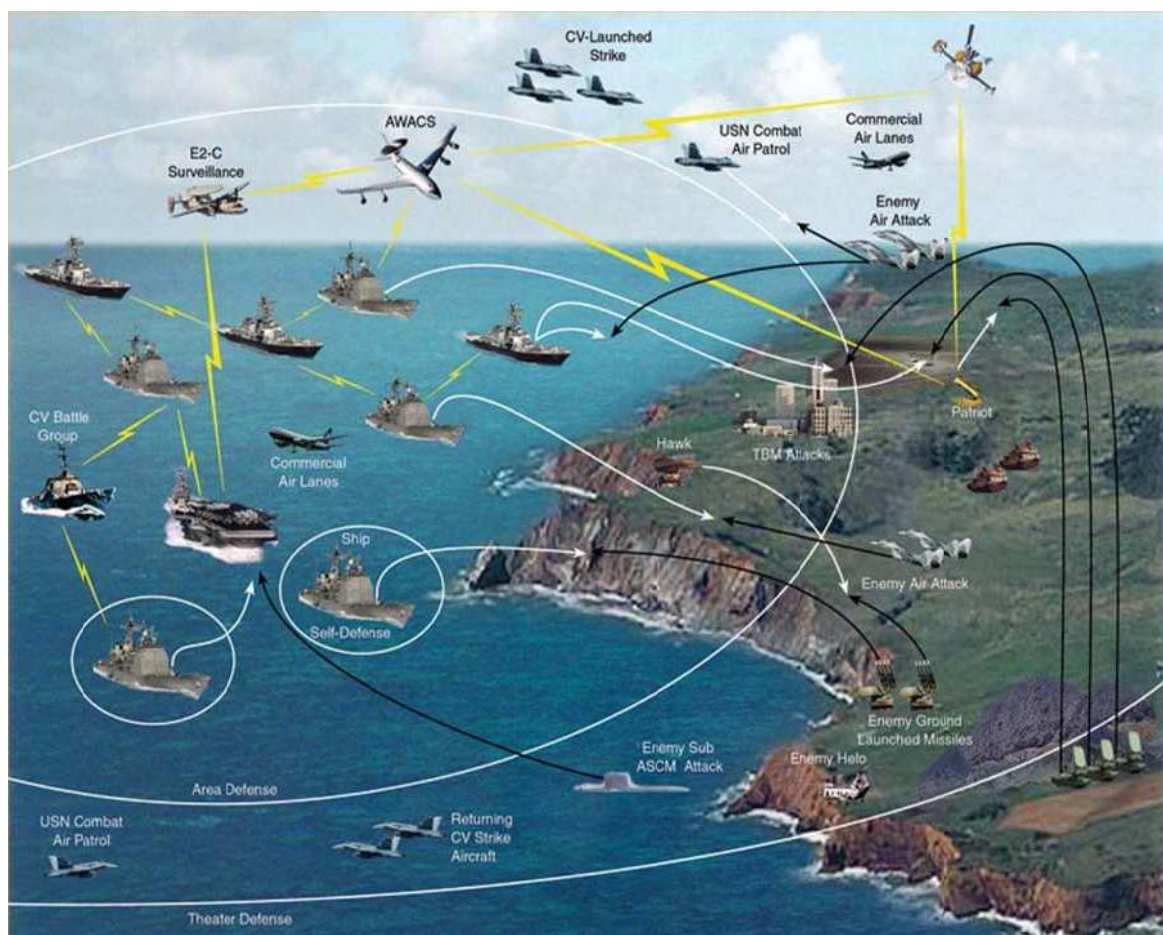

**Figure 7-1: M&S Scope: The Electromagnetic Battlespace – Threat Simulation for EW T&E – (© Northrop Grumman Amherst Systems Inc. 2006).**

M&S is used throughout the platform systems life cycle, from R&D to in-service support and training. Laboratory analysis, experimentation and M&S are playing an increasingly important role in T&E activities. High fidelity simulation enables mission level evaluation in a robust operational environment. Undoubtedly reducing the need to conduct physical equipment and system testing, they are not a complete solution. A shift in the balance between laboratory and physical testing is inevitable, but specialist and dedicated T&E ranges, facilities and supporting personnel will still be required. The challenge is to ensure the optimum mix is delivered and, as importantly, sustained.



The rapid rate of developments in the field of M&S and its sister domain Synthetic Environments (SE) prevents this chapter from being more than an introductory text on the topic. Whilst an overview of the through-life aspect is provided, it focuses on specific uses and benefits of M&S in the EW T&E process.

## **7.2 BACKGROUND, PURPOSE AND DEFINITIONS**

### **7.2.1 Background**

In the EW domain M&S was originally considered solely a tool for determining system requirements from campaign and mission requirements. Formerly also known as ‘Digital M&S,’ M&S now plays a crucial role in the process of acquiring and testing EW systems, and has long been recognised as a critical adjunct to ground and flight test. It is the thread that binds the various phases of the EW T&E Process together to enable a comprehensive conclusion about EW systems’ fitness for purpose and effectiveness. M&S itself improves with use in the EW T&E process as test results fold back into the M&S tools to improve their fidelity and capabilities and users’ confidence in them.

Historically, M&S in its wider context was problematic. The problems’ primary root causes are considered to have been inadequate and/or incomplete:

- Understanding of the required fidelity of simulations/models.
- Verification of simulations/models against their designs and specifications.
- Validation and accreditation of simulations/models against the real world and relevant measured data.
- Computing power limitations (and the resultant cost required) – a significant constraint a decade ago and still a challenge.

All too often models of unverified fidelity have been used. These have led to speculation and confusion and the consequent need for further investigations – often with significant cost and time impact. Box and Draper summarised this critical fidelity factor, which remains valid today, as “*Remember that all models are wrong; the practical question is how wrong do they have to be to not be useful.*” [1]

The increasing strengths and decreasing limitations of M&S are now evident, as enabled by the last decade’s meteoric rise in computing power and greatly improved understanding of the simulation fidelity; VV&A and related M&S topics.

Against a back-drop of severe affordability challenges world-wide, M&S is likely a key enabler for significant improvements in EW systems’ whole life affordability. As noted in Section 6.3, US and European efforts continue apace targeting realisation of the promises that M&S offers to EW T&E.

### **7.2.2 Purpose**

This chapter describes how M&S may provide unique and practical benefits to EW testers, project managers and programme sponsors. The EW T&E Process uses M&S and analysis prior to testing to help design tests and predict test results, and, after testing, to extrapolate test results to other conditions. At each stage of the test process, models in the simulation are replaced with hardware to achieve increasing fidelity to support evaluation. In this way M&S is part of all six resource categories described earlier in this Handbook. M&S is also used to provide frequent feedback for system development and improvement.

Models and computer simulations are used to represent systems, host platforms, other friendly players, the combat environment and threat systems. They can be used to help design and define EW systems and testing with threat simulations and missile fly-out models.



Due to the relatively low cost of exercising these models, this type of activity can be run many times to conduct sensitivity and trend analyses, to check ‘what ifs’ and to explore the widest possible range of system parameters without flight safety concerns. These models may run interactively in real or simulated time and space domains, alongside other combat environment factors, to support the entire T&E process.

### 7.2.3 Definitions

TERM	MEANING AND COMMENT
M&S and SE	<p>It is useful to clarify subtle differences between M&amp;S and SE, which are used extensively within [2] and [3], where both are seen to be enabling capabilities that can add significantly to effectiveness and value. For this chapter the definitions in DoD 5000.59-M, ‘DoD Modeling and Simulation (M&amp;S) Glossary’ are used. [4] These definitions are:</p> <ul style="list-style-type: none"> <li>• M&amp;S is ‘The use of models, including emulators, prototypes, simulators, and stimulators, either statically or over time, to develop data as a basis for making managerial or technical decisions. The terms “modeling” and “simulation” are often used interchangeably.’</li> <li>• SE is: ‘Internetted simulations that represent activities at a high level of realism from simulations of theaters of war to factories and manufacturing processes. These environments may be created within a single computer or a vast distributed network connected by local and wide area networks and augmented by super-realistic special effects and accurate behavioural models. They allow visualization of and immersion into the environment being simulated.’</li> </ul> <p>For the remainder of this chapter, the term ‘M&amp;S’ is taken to include SE.</p>
MS&SE	<p>As often seen with terminology used across Nations and between agencies within those Nations, different views exist on precise meanings of M&amp;S and SE. For example, in the UK’s MoD Acquisition Framework:</p> <ul style="list-style-type: none"> <li>• ‘Modelling, Simulation and Synthetic Environments (MS&amp;SE)’ is used. [5]</li> <li>• A model is defined as a static representation of an object and a simulation is a representation of how that varies through time.</li> <li>• A Synthetic Environment can comprise of those simulations, equipment and people require to represent the problem space defined to the appropriate level of fidelity.</li> </ul>
VV&A	<p>Here are the USAF VV&amp;A definitions from AFI 99-103: [6]</p> <p><b>VV&amp;A</b> – Is a continuous process in the life cycle of a model or simulation as it gets upgraded or is used for different applications.</p> <p><b>Verification</b> – Process of determining that M&amp;S accurately represent the developer’s conceptual description and specifications.</p> <p><b>Validation</b> – Rigorous and structured process of determining the extent to which M&amp;S accurately represents the intended “real world” phenomena from the perspective of the intended M&amp;S use.</p> <p><b>Accreditation</b> – The official determination that a model or simulation is acceptable for use for a specific purpose.</p> <p>There are some subtle but potentially significant differences in national terminology and application, examples of which are given in Section 7.8 and in UK DEF STAN 03-44 ‘A generic process for the Verification and Validation of Modelling and Simulation and Synthetic Environment Systems’. [7] Another critical point, again with national variations, is that the V&amp;V part generally belongs to those developing the models and simulations whilst the Accreditation part is generally the responsibility of the model/simulation user.</p>

Other common M&S terms can be found elsewhere, e.g., UK MoD's Acquisition Operating Framework. [8] Regardless of terminology and definitions, it should be stressed that whoever intends to use a model or simulation to satisfy some purpose, it is their responsibility to understand well enough how the model/simulation works to be able to determine if it will adequately satisfy their requirements.

### 7.3 OBJECTIVES

The objectives of M&S in the EW T&E process are to:

- Prove design concepts prior to final testing.
- Demonstrate system performance:
  - For elements that are either too complex or too expensive to verify by testing.
  - To supplement testing by interpolation between sparse data points.
  - To extrapolate measured test data into un-testable or unavailable regimes.
  - Where test repeatability is difficult or where tests would yield unacceptable error bounds.
- Define safety footprints or limits.
- Increase sample size once confidence in the model is established.
- Define test facility requirements, e.g., number and types of threats, airspace required, control of background noise and emitters, and instrumentation.
- Define and optimise test scenarios.
- Select test points, i.e., successful results would not indicate the need for additional heart-of-the-envelope testing.
- Predict test results for each test objective.

Provide a complex, operationally realistic environment.

### 7.4 M&S CATEGORISATION AND LEVELS OF COMPLEXITY

EW models and simulations are generally categorised and constructed to the levels of technical complexity commensurate with their intended use, as shown in Table 7-1. This Table expands upon Table 6-2 in the introduction to M&S within Chapter 6.

Table 7-1: M&S Categorisation and Levels of Complexity.

LEVEL	TYPICAL APPLICATION	COMMENT	TYPICAL OUTPUTS
Campaign (Operations, Theatre)	<ul style="list-style-type: none"> <li>• Optimum force allocation, force mix studies.</li> <li>• Balance of Investment trades, e.g., Strike vs. ISTAR assets.</li> <li>• Availability analysis, i.e., sortie generation rates, concept reliability and maintainability.</li> <li>• Logistics and spares support and footprint analysis.</li> <li>• Force-on-Force interactions occurring <b>over several days</b>.</li> </ul>	<p>This level incorporates the Command, Control, Communications, Computers and Intelligence (C4I) contributions of joint-Service (i.e., Army-Air Force-Navy) and Allied Forces operations against a combined threat force (force-on-force). It integrates the various missions into regional, day and night, and joint operations, and assesses the input of EW on force effectiveness.</p> <p>Campaign level is similar to mission level except that a campaign is a many-on-many simulation including the impacts of having to sustain the mission for an extended period of time. It evaluates effectiveness and force survivability of friendly, multi-platform composite forces opposing numerous threats, but also includes the issues associated with human factors, logistics (including battle damage repair), and attrition.</p>	<p>Answers to the questions:</p> <ul style="list-style-type: none"> <li>• Did we win the campaign/war?</li> <li>• How long did it take?</li> <li>• At what overall cost?</li> </ul>
Mission and Multi-Mission	<ul style="list-style-type: none"> <li>• Weapon system concepts and CONOPS trade-offs (e.g., survivability).</li> <li>• Force mix / group operations analysis (e.g., value of support jamming).</li> <li>• “Many on Many” interactions <b>over several hours</b>.</li> </ul>	<p>Multiple weapon systems level models (with varying degrees of detail) combined into a simulated mission to analyse mission effectiveness and force survivability of friendly, multi-platform composite forces opposing numerous threats (many on many). Mission level models frequently include the impact of the enemy’s command and control capability on the outcome. Sometimes contractors are tasked by defence ministries to use this level of modelling to evaluate contributions and cost of various configurations. Thus in some cases, the contractor thus defines (for example) required levels of signatures and DAS.</p>	<p>Answers to the questions:</p> <ul style="list-style-type: none"> <li>• How many sorties were required to achieve the given mission objective?</li> <li>• How many engagements did we face?</li> <li>• Probability of successfully completing the mission.</li> </ul>

**MODELLING AND SIMULATION FOR EW T&E**

LEVEL	TYPICAL APPLICATION	COMMENT	TYPICAL OUTPUTS
Engagement	<ul style="list-style-type: none"> <li>Platform level, e.g., weapon system, sensor suite and DAS trades.</li> <li>Tactics exploration and optimisation.</li> <li>Few on Few engagements, <b>over many minutes</b>.</li> </ul>	<p>Weapon system level models are used to evaluate effectiveness, including associated tactics and doctrine, in the context of an integrated weapon system engaged with a single (one-on-one) or a few (one-on-few) enemy threats (e.g., SAM systems) in a simulated scenario.</p>	<ul style="list-style-type: none"> <li>Aircraft ‘state vector’ at end of engagement, i.e., position, speed, fuel, weapons, expendables, etc.</li> <li>Engagement outcome, e.g., in an ‘m vs. n’ air-to-air combat, how many emerge on each side unscathed / needing to return to base.</li> <li>Length of engagement and significant events, e.g., point of detection, recognition, weapon release, threat emitter activity.</li> </ul>
Engineering (System)	<ul style="list-style-type: none"> <li>EW sensor and ECM performance analysis.</li> <li>Alleviating RF interoperability issues.</li> <li>Analysis of system interaction with RF and electro-optical/IR/UV environment, e.g. natural and man-made clutter.</li> <li>One vs. One system interaction <b>over many seconds</b>.</li> </ul>	<p>The main difference between engagement level models and system level models: the former tends to emulate the effect of EW often assuming a lot, whereas the latter simulates ‘the physics’ of the EW interaction and assumes very little. A key element of this level for EW, radar and radio systems is establishing <i>optimal installed performance</i>, as platforms – especially aircraft – invariably preclude achieving theoretical maximum performance.</p>	<ul style="list-style-type: none"> <li>Antenna gain vs. angle tables (for on board ECM, towed decoy, threat radar).</li> <li>Optimal RF/EO/IR/UV sensor and effector (ECM) positions on platforms, to maximise survivability and mission success probability.</li> <li>ECM technique effectiveness vs. given threats.</li> <li>Jammer power, bandwidth and other requirements.</li> <li>Chaff dispersion rated and characteristics.</li> <li>DIRCM cueing accuracy from MW models.</li> <li>RF/IR/UV threat emitter scenarios.</li> </ul>
Engineering (Sub-System)	<ul style="list-style-type: none"> <li>Component R&amp;D.</li> <li>Circuit analysis.</li> <li>Interactions typically occurring in <b>fractions of a second</b>.</li> </ul>	<p>Modelling used to examine technical performance of an individual component or LRI/LRU or sub-system in accordance with their intended designs.</p>	<ul style="list-style-type: none"> <li>Impedance requirements.</li> <li>Power and cooling requirements.</li> <li>Switching speeds.</li> <li>Memory requirements.</li> </ul>

Categorisation schemes vary, although there is significant commonality – the differences largely concern the resolution required of the models and simulations, i.e., how much detail is appropriate for the questions being asked? For example:

- In some schemes the ‘Campaign’ level is called ‘Operations’ and in others ‘Theatre,’ whilst others have Campaign and Theatre as separate levels. In this Table all three are considered to be under the ‘Campaign’ header.
- Likewise some schemes only have an ‘Engineering’ level, whereas others decompose this into ‘System’ and further into ‘Sub-System,’ ‘Equipment’ and ‘Component (or ‘Circuit’). In this Table only two levels are used: ‘Engineering (System)’ and Engineering (Sub-System).

## **7.5 APPLYING M&S IN THE EW TEST PROCESS**

M&S supports EW testing throughout the EW Test Process as shown in Figure 1-6 to plan (predict), conduct (test), and analyse (compare) the test programme and evaluate SUT performance. M&S tools consist of two parts: the battle environment and the SUT. The battle environment includes software representations (models) such as the enemy’s weapon system (threat) and the propagation environment. The SUT (often referred to as the Digital System Model, DSM) includes software representation of the friendly weapon system, such as the aircraft, including any electronics critical to the evaluation.

### **7.5.1 Defining System Requirements**

M&S tools are used to examine theatre, campaign, and mission needs to determine the requirements for new or upgraded EW capabilities. Once a requirement is established, M&S tools are used to determine performance characteristics required in the EW system.

EW system performance requirements are stated as MOEs that are decomposed into MOPs from which test objectives can be derived. M&S plays a key role in the process of defining test requirements based on what information is needed about the EW system. MOEs and MOPs become the basis for planning an EW test programme, and M&S provides the tools to feed back the EW performance observed during testing into the original simulations used for determining EW performance requirements.

### **7.5.2 M&S in the EW Test Process**

With MOEs in hand, the test team begins the test process designed to gain incremental information on the EW system’s performance, increasing confidence the system will perform effectively in combat. Figure 7-2, which is similar to Figure 1-11, shows a logical flow of test activity from left to right.



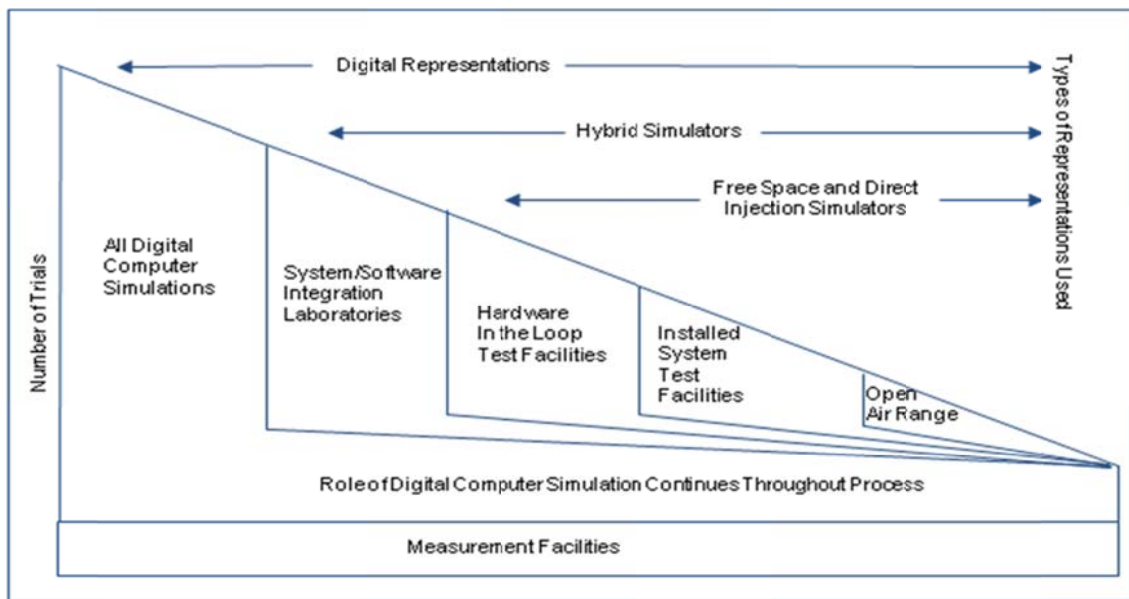

**Figure 7-2: Activities Within the M&S Interface.**

MFs (such as radar cross-section and antenna pattern measurement ranges) support the process continuously as needed. The majority of activity at these facilities occurs early in the process. All computer simulation also begins early in the process. It is used to assist in design, trade-off studies, system integration decisions, and test planning. As this chapter shows, M&S provides support throughout the EW test process. SILs provide the capability of testing individual EW system components (for instance, in ‘brassboard’ configurations) and sub-assemblies in a laboratory environment. HITL facilities allow testing the interactions of assembled EW systems with a simulated environment representing the threat situation. Frequently, the simulated environment at the HITL will include threat hardware integrated with simulation to create the battle environment. Once the EW system is integrated with other avionics on the aircraft, the integrated systems are tested in the ISTF to ensure compatibility of the various systems involved and that the EW system performs as expected when connected with other aircraft systems. The final test phase is flight testing at an OAR.

Figures 1-6 and 1-11 emphasise the continuing role of M&S throughout the EW Test Process. At each test facility, software tools play important roles in supporting test conduct and interpreting results. The roles of M&S at each test phase are very similar. Figure 7-2 graphically depicts how M&S fits in to these test phases. It is not appropriate for all M&S activities to be employed at all test phases, so the functions shown are turned on and off depending on the specific needs of the test.

A ‘seamless’ test process greatly benefits from continuity in the M&S functions shown in Figure 7-2. The M&S tools used for test support should be used to support simulations used at each facility. For instance, the target representation used at the HITL should be traceable to the target representation in the M&S. Models must have the appropriate fidelity to achieve the test objectives for a given phase of testing. The functions shown in Figure 7-2 apply generically to any EW test facility, but the model fidelity required can vary from facility to facility. For instance, in early phases – such as the SIL, a basic model of the SUT may be sufficient for some T&E activities. In subsequent phases, a more detailed and higher-fidelity system model is generally required, depending on the evaluation objectives.

An overview of how M&S facilitates and shapes EW testing is shown in Figure 7-3. The M&S function in each block is briefly explained later in this chapter along with a short example of each. M&S plays key

roles before, during, and following each phase of testing. M&S allows system characteristics measured and reported in engineering units to be translated into terms reflecting overall system effectiveness. Through analysis using M&S, results from one phase of testing can be used to define and optimise testing at subsequent facilities. This makes M&S an excellent risk reduction tool in the development of a friendly weapon system. This is a valuable capability since, in general, the expense of test hours increases as testing progresses from SILs, through HITL facilities and ISTFs to OARs.

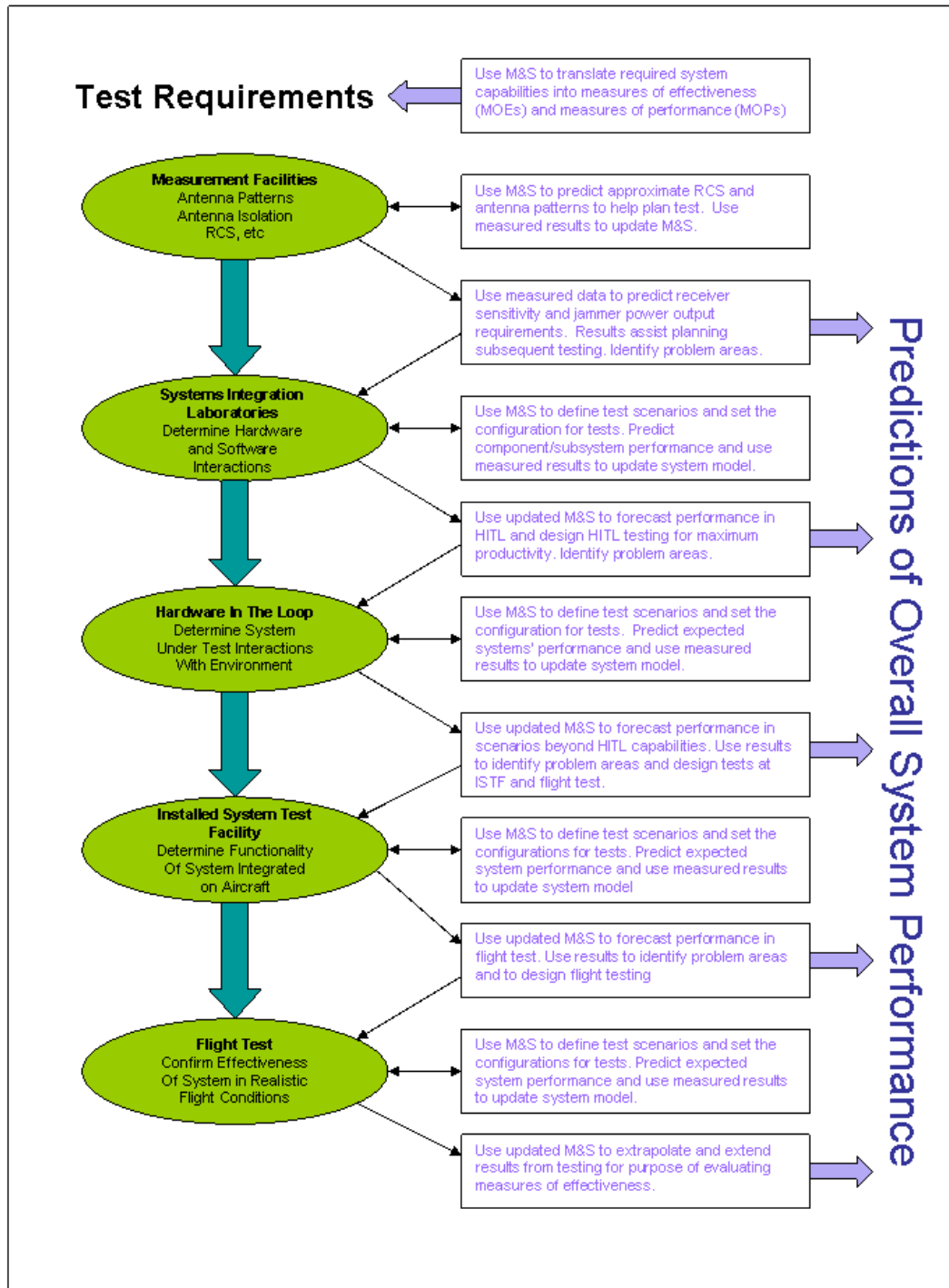
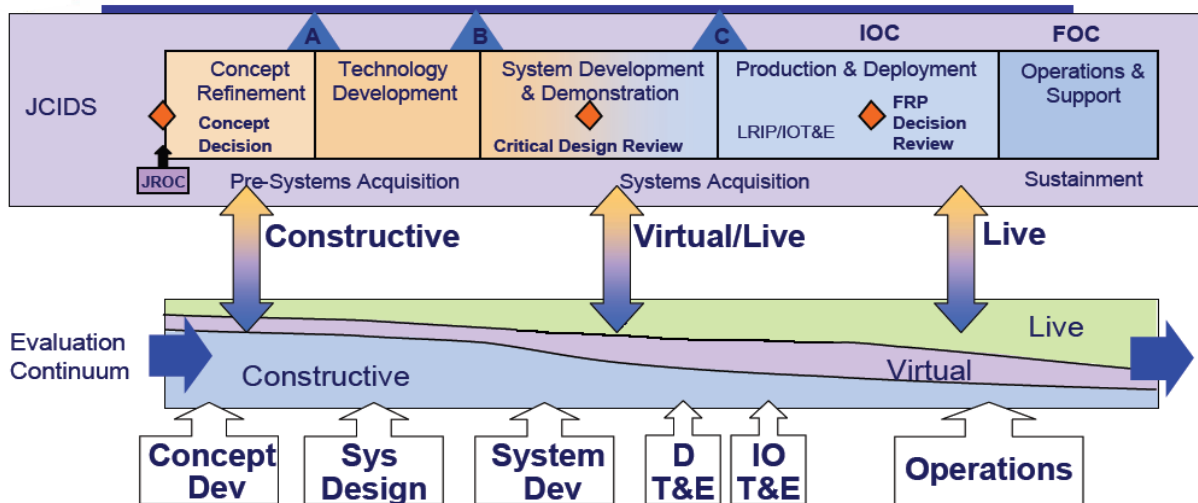

Figure 7-3: M&S Activities at Test Phases.

Figure 7-4 shows the DoD Live Virtual Constructive (LVC) continuum. Within the EW T&E activities there is likely to be mix of simulations and real equipment. The mix of this will differ through the life cycle depending on the maturity of the solution. Within this construct T&E could be performed earlier in the life cycle than it has been done traditionally, but with more simulation-based solutions. As the solution matures, real equipment will gradually replace the simulations providing a gradual de-risking process.



**Figure 7-4: M&S Activities Supporting EW T&E: The DoD LVC Continuum.**

At the conclusion of the ‘test’ phases, M&S plays a major role in extrapolating performance observed in test to operationally realistic scenarios as defined in the requirements document for the system. During the test process, confidence grows in the conclusions concerning the weapon system’s performance. Confidence is also increased in the M&S tools since measured results provide feedback for model refinement and validation. The completed set of M&S tools can then be used to explore the EW system’s performance in conditions that cannot be tested at the various facilities. At completion of testing, the validated M&S tools are available for a wide variety of analysis applications.

## 7.6 M&S ACTIVITIES SUPPORTING EW T&E

The following paragraphs provide generic descriptions of each of the key M&S applications.

### 7.6.1 Quantify Test Conditions

The use of M&S to quantify test conditions provides a firm foundation for subsequent testing using the EW T&E Process. An Analysis of Alternatives (AOA) is conducted to develop mission scenarios and evaluate effectiveness and cost trade-offs. At this stage, there are no detailed system parameters available (for example, known performance in terms of response times, jamming waveforms and the like) nor specific system performance requirements. The AOA first determines if future defence strategies require the development of a new weapon system or sub-system.

The AOA process develops operational mission scenarios including target analysis, threat system deployment, and development of realistic mission profiles. The missions are simulated and analysis of the resulting interactions between the weapon system and the threat quantifies the frequency of occurrence that specific threats engage the aircraft. The parameters of the engagement conditions such as range, offset, and the presence of other threat systems and their emissions are also predicted. The predominant

and most stressing conditions challenging system performance are identified by the M&S analysis. These provide quantified descriptions of candidate test conditions that are used to design test configurations for each of the test facility categories and specific test runs.

### **7.6.2 Design Tests**

Based on the candidate test conditions, M&S is used to design and plan tests which obtain the most usable test points per test hour. The candidate test conditions are refined to account for limitations of the test facilities to define Reference Test Conditions (RTCs). M&S tools are then configured to simulate the RTCs for designing a set of test runs that vary key aspects of the test conditions. These are the Planned Test Conditions (PTCs) which result in the most test points for the test run matrix.

This use of M&S helps the test team to define an efficient test matrix by identifying conditions where MOP values change so no more sample test points than are needed will be planned. This improves overall test efficiency by concentrating test resources productively. Because flight test hours are usually limited based on funding constraints, using M&S for test design will not always reduce flight test hours, but it does help focus the flight test on critical data requirements.

### **7.6.3 Predict Test Results**

The test team can use M&S to predict the expected values for each MOP in the test matrix. The predicted values support 'Quick Look' analysis to detect problems with the test execution if the test results differ significantly from the predictions. Test prediction is not a new concept nor is the use of M&S to help design and predict results. For years, M&S has been used in this fashion for flight performance testing and for space programmes. In their application to the EW Test Process, M&S tools become more detailed and accurate as they are validated with test data. The test team can also use the M&S tools to control the instrumentation and data reduction process by identifying essential data acquisition points. In many cases, data obtained from M&S can be used to test the analysis process to be used for actual test results. This can uncover problems in the analysis processes before actual testing begins.

### **7.6.4 Simulate Elements**

Simulation plays a key role in many phases of testing. For instance, accurate simulations of threat radars and other emitters in the scenario are necessary to provide sources of realistic signals used to test the SUT capabilities in a dense signal environment in the SIL. This topic is discussed later in this chapter.

Another important element often available only in a simulation is the threat missile seeker hardware. For HITL testing of the SUT interaction with seeker-dependent missiles, accurate models of the missile fly-out are necessary to obtain proper seeker geometry and RF/IR/UV conditions for the test. M&S supports these and other requirements to construct meaningful test conditions by providing suitable output representations of threat activity from validated modules representing their hardware counterparts.

### **7.6.5 Quantify Test Results**

M&S provides the link between what can be measured from testing and what must be known about the associated impact on aircraft survivability at all phases of testing. M&S can aggregate measured data from testing and project it into predicted system effectiveness terms that allow more direct evaluation of system capabilities.

### **7.6.6 Compare Predicted and Test Results**

It is important to compare results predicted for the test using M&S with actual results. One reason for doing this is to gain confidence in or refine the M&S. Arguably, a more important reason is to 'sanity

check' test results. In cases where measured results disagree with predictions, there is always a chance that problems with the test setup, execution, or data collection are the cause. Having confidence in the predicted results allows problems with the test to be quickly identified and corrected.

### **7.6.7 Extrapolate Test Results**

For various reasons (cost, time, resource limitations, or safety), testing cannot collect measured data at every possible point in the region of interest. M&S can be used to increase the sample size by simulating those events that could be encountered operationally but could not be included in the test design.

M&S is also used to extrapolate results to higher level MOEs than can be directly tested. For example, tracking error, which is a MOP, is extrapolated to miss distance by simulating the missile fly-out. The miss distance for numerous test runs is then analysed to obtain the Reduction in Lethality MOE (see Annex B).

Validation of the M&S models and extrapolation of results provide the test team with tools to connect the MOPs to system effectiveness, which make test results meaningful to programme management in reaching decisions concerning the programme.

## **7.7 EXAMPLES OF APPLYING M&S DURING TEST PHASES**

This section describes how a test team can use M&S at each test phase. It is not a comprehensive description of M&S throughout the EW T&E Process, just a sampling of how M&S can be used. One example MOP is selected for each process phase to illustrate contributions of M&S at each test phase.

As testing progresses through the process, the test team collects more measured data. As a result, there will be a reduction in remaining MOEs/MOPs to be predicted through simulation. As a specific example of this process, measured installed antenna patterns obtained at the measurement facility will replace the engineering estimated antenna patterns in the DSM. The MOEs/MOPs will be computed or re-computed using the updated model(s).

### **7.7.1 MF Example: Antenna Pattern Measurement for Field-of-View MOP Assessment**

A platform's RWR antennas must provide visibility throughout the required range of azimuth and elevation. If the achieved field-of-view coverage is inadequate, the RWR will not provide warning for threats located outside the achieved field of view.

**Design Test:** The DSM will be used to specify sampling intervals and resolution required in measurements to ensure the resulting collected data are sufficient (but not wasteful 'overkill') for supporting subsequent modelling which uses the measurements as input data.

**Extrapolate Test Results:** The DSM will be stimulated with analytically combined measured antenna pattern data to observe predicted SUT performance in response to frequency and polarisation combinations not actually part of the measurement plan.

### **7.7.2 SIL Example: Detection Range MOP**

The platform's RWR must warn the aircrew at a range from the threat that allows employment of suitable countermeasures. If the achieved detection range is inadequate, warning time will not be adequate to allow effective countermeasures.



**Design Tests:** SAMs and Airborne Interceptor systems, emitters and environment models can be used to generate expected power levels for testing jammer and RWR threat detection capabilities. The corresponding values of power will be used to design the test setup and data collection efforts. In other words, the test team will use this power as the starting point and proceed up or down in the scale as necessary to characterise detection capability.

**Predict Test Results:** The DSM, threat, environment, and aircraft models will be used to predict the range between the aircraft and threat at which the SUT initially detects each threat along the test scenario.

**Extrapolate Test Results:** Validated DSM models will be used to extend the measured results to include assessment of detection range performance against emitters not available in the SIL. This allows follow-on analysis to incorporate newly assessed threat capabilities and opens up the possibility of deployments without re-visiting the SIL facility.

### **7.7.3 HITL Example: Track Error MOP**

Output jamming waveforms must cause sufficient degradation in threat tracking of the aircraft to prevent damage or destruction by a missile or AAA.

**Design Tests:** Threat models capable of predicting threat radar responses to ECM (called 'EC-capable' models) are used to evaluate the capability of the self-protection system to achieve a given degradation in threat tracking performance at various target offsets and altitudes. Resultant effectiveness estimates are used to design the HITL test setup and to specify offsets and altitudes.

**Predict Test Results:** DSM, threat, and environmental models are used to establish expected values of the resultant track error. Threat models used for this must be EC-capable.

**Extrapolate Test Results:** DSM and EC-capable threat models are used to extend results measured in the HITL to include assessment of SUT-threat interactions in conditions not actually measured at the HITL, to show SUT sensitivity to changes in environmental and/or threat factors that influence tracking error.

### **7.7.4 ISTF Example: Pulse Density MOP**

Systems must be capable of collecting and processing all incident pulses expected in the aircraft scenario, subject to the specified tolerable pulse drop-out. If achieved pulse processing capability is inadequate, the system cannot effectively perform when conditions of pulse density are above the achieved capability.

**Design Tests:** Emitter, threat, and environmental models will be used to establish incident signal conditions at representative pulse densities for an operational scenario. These signal conditions will be used to design the test set-up and data collection effort at the ISTF.

**Predict Test Results:** The aircraft, DSM, emitter, threat, and environmental models will be used to predict SUT performance in the presence of the signal conditions derived above.

**Simulate Elements:** Motion of aircraft and other moving platforms of interest is simulated using M&S.

**Extrapolate Test Results:** Full simulation including the aircraft, DSM, emitter, threat, and environmental models can expand the scope of SUT evaluation by extending it to combinations of laydown, scan schedules, mission profiles, and other conditions not actually measured at the ISTF.

### 7.7.5 OAR Example: Reduction in Shots MOP

Jammers must sufficiently decrease the opportunity for missile launches with ECM versus without it. If sufficient shot opportunities cannot be denied, overall jamming effectiveness will be inadequate.

**Design Tests:** Aircraft, DSM, and threat models will be used to design flight tests that provide shot opportunities covering each tested threat system's engagement envelope and the mission envelope of the aircraft. Results of simulation will be used to design data collection, select threat rules of engagement (such as cueing and firing interval), and reference time TSPI coverage requirements.

**Predict Test Results:** Simulations used to design the flight tests will be run using derived test conditions to produce expected shot rates achievable by the threats under ECM and non-ECM conditions.

**Extrapolate Test Results:** M&S is used to extend results achieved at the OAR to include relevant threat density and combinations that are not available at the OAR, and, where necessary and possible, to include effects of tactics that were not employed during flight testing due to test restrictions.

## 7.8 SIMULATION FIDELITY, CREDIBILITY AND FITNESS FOR PURPOSE

### 7.8.1 M&S Fidelity and VV&A – RF Threat Simulation as an Example

This section discusses fidelity and VV&A as applicable to M&S as used in EW T&E. Sections 6.9.1 and 6.9.2 have already touched on fidelity under the topic of distinguishing factors of test facilities. This section expands on the topic with specific reference to RF threat simulators, a mainstay of many EW T&E facility categories. [9] As will be seen in this section, this can be seen as a general case for the consideration of any model or simulation to be used in the EW T&E process.

### 7.8.2 Definitions

There are many views of the meanings of the terms used to describe how faithful a representation of something is provided by a 'model' or a 'simulation'. Many years ago definitions were relatively straightforward: a simulation could have high or low fidelity. At its highest level of fidelity, the simulation became an emulation of the item concerned. As such it was identical to the item in all respects relevant to the emulation's use.

Nowadays terms such as 'model,' 'simulation/simulator,' 'emulation/emulator,' 'replication/replicate,' 'surrogate' and 'hybrid representation' often have multiple meanings, dependent upon Nation, agency, technical sector/domain, topic/aspect/item of concern and stage in the platform/equipment life cycle. In some countries references exist to aid clarity of this multiple usage but these are not international standards per se.

It is thus necessary to define the meaning of specific terms in the context of this section:

- **RF Emitter Simulation:** Imitation, at RF, of the real-world characteristics and behaviour of one or more RF emitters, to a given level of fidelity. Note: Simulations/simulators are usually more cost-effective than using real threat weapon system radars for most test missions.
- **Simulator Fidelity:** The measure of the quality of RF emitter simulation when compared to the real emitter, for all those spectral, spatial and temporal aspects relevant to the simulator's use in EW T&E.
- **Emulation:** Highest fidelity simulation, where a perfect EW receiver could not discriminate between the emulation and the real emitter. Note: Emulations/emulators are useful where the use of the real item is either not necessary or is undesirable.

- **Verification:** The process of determining that an EW receiver system, when tested using a threat simulator incorporating threat emitter models, meets its contractual specification.
- **Validation:** The process of determining whether the:
  - Simulator’s output, when programmed with threat emitter models, is adequate for its intended use in the T&E process.
  - SUT, when programmed with theatre-specific Mission Data, correctly identifies and reacts to real/simulated threat emitters.
- **Accreditation:** The process of determining whether a simulator’s rendition of threat emitters is suitably realistic, robust and credible.

### 7.8.3 Threat Simulation Fidelity

Threat simulation fidelity is dominated by two factors – threat emitter characteristics programmed into a simulator and the simulator’s capability to translate those characteristics into a faithful representation of the RF signals that would be received by the SUT’s antennas when radiated by the real threat under combat conditions. As with any simulation, a threat simulator’s capabilities need to be fully understood in terms of the VV&A processes for M&S, and for SUT performance V&V. [10]

Table 7-2 depicts VV&A from a threat simulator standpoint.

**Table 7-2: Threat Simulators and VV&A.**

PROCESS NAME	OBJECTIVES	KEY QUESTION	PROCESS ACHIEVES	DONE BY
<b>VERIFICATION</b>	Uses simulator to confirm that SUT meets its specification	Was SUT built correctly?	Tests <b>FUNCTION and PERFORMANCE</b>	SUT suppliers and platform/systems integrator
<b>VALIDATION</b>	Confirmation that: <ul style="list-style-type: none"> <li>• Simulator produces adequate representation of emitters</li> <li>• SUT, when programmed with theatre-specific mission data, correctly identifies simulator-generated emitters</li> </ul>	Do simulator-generated emitters look and behave sufficiently like the real thing?	Evaluates <b>FIDELITY</b>	Military, often with Industry support
<b>ACCREDITATION</b>	Certification that [simulator + threat emitter data] is adequate for proving [SUT + mission date] is fit for intended military purpose	Can simulator be used to optimise and validate mission data for EW receiver systems?	Determines <b>CREDIBILITY</b>	Military, often with Industry support

Various methods are used to confirm (or ‘validate’) the fidelity of a simulator’s rendition of threats. National methods vary and a good example is the US CROSSBOW (Construction of a Radar to Operationally Simulate Signals Believed to Originate Worldwide) process, run by a tri-service technical agency established for the common development of EW RF simulators. It assures that simulators and models are consistent with intelligence agency threat estimates and that validation procedures are being followed. It then certifies simulator-model combinations for use for specific EW T&E cases via accreditation tests.

#### **7.8.4 Fidelity, Affordability and the Limits of M&S Utility**

Whilst it is philosophically possible to satisfy all VV&A requirements for any given system by M&S alone, there are significant obstacles that preclude its achievement. The primary reasons are affordability and computing power. Generally a better simulation needs improved fidelity and, generally, increased fidelity equals increased cost of implementation and model/simulation maintenance. It is thus considered unlikely that systems will ever be fully cleared by M&S also, i.e., without some residual element of SUT ground test and flight trials.

Again using the example of RF threat simulators, it has been long recognised that achieving emulation of combat air RF environments using simulators is utopian. The combination of affordability, highly complex electromagnetic interactions experienced in the real world and simulator technology limitations is likely to constrain simulations to limited resemblance to the high-pulse density, confusing electromagnetic ‘mush’ that is often the electronic battlespace in modern conflicts.

However, with reference to the definitions in Section 7.8.2, a perfect EW receiver is unlikely to ever exist. Thus the question is really whether a simulator provides sufficient fidelity for the SUT to be unable to discriminate between its outputs and emitters in the real-world RF environment. This, as for other areas of avionics T&E, is a question of adequacy – there is no need to generate significantly better fidelity than the SUT can measure.

In terms of adequacy, there are a number of rules of thumb that suggest T&E equipment should be able to simulate/generate/measure to an order better than the SUT can measure. Whilst often possible in the digital context, this is less easy in the RF world but modern simulators can, for most parameters, easily exceed the parameter range of the SUT. It is less easy, even given today’s technology, to significantly improve on parameter accuracies and resolutions, though few problems have been reported in this area.

It is clear that much more can be achieved by M&S, but that the affordability boundary between M&S and testing needs to be determined carefully for each function and performance element requiring verification.

This situation has been examined for RF threat simulators, see [9], where a number of enhancements to the then existing state-of-the-art simulator were identified that appeared to promise the fidelity level where more of the T&E currently done by flight testing against real threat emitters could to be executed within the anechoic chamber and laboratory environment – offering cost saving, repeatability and investigation benefits. Once the above simulation fidelity level has been realised, the need for any further fidelity increase will need to be cost-benefit traded to determine whether the required tests might be better conducted via OAR flight trials. This situation is also in line with the US Defense Modeling and Simulation Office’s view on ‘State of the Art in Fidelity’. [11]

#### **7.8.5 Fidelity Description**

When determining fidelity requirements for a model or simulation it is important to provide quantitative fidelity descriptions if the model/simulation must produce critical parameters to specified levels of accuracy. [12] Qualitative (High/Medium/Low) descriptions lack the information content necessary to

support technical decisions about simulation fitness for a particular purpose. Fidelity needs to be characterised in terms of resolution, error/accuracy, sensitivity, precision and capacity.

### 7.8.6 M&S Credibility and Fitness for Purpose

Maximum benefit is reaped from models and simulations when their function and outputs are credible and their fidelity is sufficiently high to be affordably fit for purpose for the task at hand. Much has been written on these topics, too much to individually reference in this Handbook. The interested reader is referred the NATO Modelling and Simulation Working Group, see Section 7.9, and their National M&S agency, for guidance and other sources of information.

M&S credibility is hugely influenced by the overall experiment design process (use the right models together with the right data) and the overarching V&V process applied to that.

There are simulation processes that exist that are aimed at providing transparency and fitness for purpose. These are primarily the Federation Development and Execution Process (FEDEP) and Distributed Simulation Engineering Experimentation Process (DSEEP). [13],[14] Note that FEDEP, although known to still be in use at the time of this Handbook's issue, has been superseded by DSEEP, which was approved as a recommended IEEE standard in January 2011.

The DSEEP process builds on the FEDEP process and is a generic process which is clarified by the following steps, whose content is also outlined below:

- **Define Simulation Environment Objectives (Step 1)**
  - **Identify User and Sponsor Needs:** The requirement to produce an M&S application is started by a specific need. It is important to establish a clear understanding of the User's and Sponsor's goals.
  - **Develop Objectives:** A detailed set of specific objectives are developed and documented. The capability of M&S to be able to address these objectives is assessed in terms of cost, required timescales, risks, availability of personnel, supporting tools, security issues, network constraints, potential solution approaches, and facilities.
  - **Conduct Initial Planning:** Initial planning documentation is produced in terms of the Simulation Environment Development and Execution Plan (SEDEP), incorporating an approximate schedule with identification of major milestones, and addressing such issues as configuration management, test, security and V&V.
- **Perform Conceptual Analysis (Step 2)**
  - **Develop Scenario:** The objectives identified in Step 1 are assessed in terms of how they might be represented in the real-world domain, and from this a prototype scenario is developed. Several vignettes may be produced in order to fully satisfy the objectives. Scenario information should include the number and types of all the main entities, their positions, capabilities and behaviour, and scenario exit criteria. Geographical location and environmental conditions should also be specified. Potential reuse of previously established scenarios should be considered.
  - **Develop Conceptual Model:** From this information, the conceptual model can be established and documented. This is a real-world, implementation-independent representation which transforms the original objectives into a set of functional and behavioural descriptions designed to meet them.
  - **Develop Simulation Environment Requirements:** Detailed requirements for the simulation are established from the conceptual model and extend to consider the simulation environment



specific issues such as exercise control, monitoring, data logging and analysis, networks, test criteria, etc. Documented requirements should be traceable from the conceptual model to the original objectives.

- **Design Simulation Environment (Step 3)**
  - **Select Members:** Components of the Simulation Environment (known within DSEEP as 'members') are selected, and may vary in size from small elements to complete simulation environments in themselves. It is important to determine if pre-existing members can be reused (with the aid of a repository, if available), and to what extent they may need to be modified. Rationale for member selection should be documented.
  - **Prepare Simulation Environment Design:** The design of new members will need to be established, and the complete simulation environment design should be documented, including its overall infrastructure and selection of protocol standards.
  - **Prepare Detailed Plan:** A detailed plan for the established design is put in place. This involves updating and extending the initial SEDEP put in place in Step 1.
- **Develop Simulation Environment (Step 4)**
  - **Develop Simulation Data Exchange Model:** The information exchange data model defines how members within the simulation environment will interact with each other at runtime. This will depend, for example, upon whether an object oriented approach is being taken, or to what extent the simulation is distributed across a number of locations. The data exchange model developed should be fully documented, and must conform to the conceptual model established in Step 2.
  - **Establish Simulation Environment Agreements:** This activity is designed to ensure that all other agreements relating to interoperation are fully established before the simulation is implemented. Issues to be considered may include:
    - The need for any further software modifications to pre-existing members.
    - The need to ensure database and algorithm consistency, where appropriate.
    - Identification of definitive data sources for members and simulation environment databases.
    - Runtime management agreements, synchronisation points and initialisation procedures.
    - The definition of a save and restore strategy.
    - The definition of security procedures.
    - Data publication and subscription responsibilities.
    - Scenario instances required.
  - **Implement Member Application Designs:** During this activity, existing members are modified and member interfaces are constructed, adapted or extended as necessary. New members are implemented along with supporting databases and scenario instances.
  - **Implement Simulation Environment Infrastructure:** At this point, the required network software and hardware infrastructures are created and configured, and the facilities required to support integration and test are fully prepared. This includes availability of hardware, system administration, building air conditioning and power supply; and all other software and hardware configuration necessary. The infrastructures should be fully tested before going on to the next step.

- **Plan, Integrate and Test Simulation Environment (Step 5)**
  - **Plan Execution:** The SEDEP should be updated to take into account all the latest developments, paying particular attention to addressing V&V, test and security issues. All risks and mitigation strategies should be re-assessed, and plans for the detailed execution of the simulation fully documented.
  - **Integrate Simulation Environment:** The purpose of this task is to incorporate all members into their intended locations within the simulation environment infrastructure. Detailed progressive testing should be carried out during this process in accordance with the SEDEP, and software problems encountered should be fixed and re-tested.
  - **Test Simulation Environment:** The fully integrated simulation environment is formally tested to ensure that it can meet all its specified objectives. Test results should be reviewed with both users and sponsors, and any necessary corrective actions carried out.
- **Execute Simulation Environment and Prepare Outputs (Step 6)**
  - **Execute Simulation:** All planned simulation executions take place in accordance with the SEDEP, and all raw data outputs collected. Any problems should be documented.
  - **Prepare Simulation Environment Outputs:** Any pre-processing that is required to be carried out on the raw execution data outputs now takes place to ensure that it is in the appropriate format for subsequent analysis. This data, along with any execution problems encountered, should be reviewed to assess if there may be a need to re-run some of the simulation executions.
- **Analyse Data and Evaluate Results (Step 7)**
  - **Analyse Data:** The processed data from Step 6 is analysed using appropriate tools and methods, and results prepared for feedback to the User and Sponsor.
  - **Evaluate and Feedback Results:** The results are fed back to the User and Sponsor for evaluation, and an assessment made that the objectives of the Simulation Environment have been met. Those products developed or modified during the development process should be archived for subsequent re-use where appropriate. Lessons learned should be captured, and a final report produced.

The V&V process is an overlay over the whole of the above process, not something that is done at the end. Following the above process and learning from the experience outlined in Chapter 9 should ensure appropriate fitness for purpose and credibility, at an optimal cost and with minimum risk.

### **7.8.7 M&S Problems and How Best to Avoid Them**

Various groups have, over the years, performed root cause analyses for problems with M&S across a wide number of domains, not just T&E. One example, given in [15] and Table 7-3, provides a typical 'Top Ten' list of reasons for M&S 'unfitness' for purpose.

**Table 7-3: Top 10 Reasons for M&S 'Unfitness'.**

1	People do not have enough relevant experience.
2	Evidence does not support a fitness argument.
3	Development process is wrong for the purpose.
4	Configuration management is unsuitable for the purpose.
5	Lack of recorded assumption information.
6	Data sets used in the model are inaccurate.
7	Incorrect level of modelling resolution.
8	People do not have enough training.
9	Data set is not coherent with the purpose.
10	Evidence of fitness is missing.

To elevate confidence in M&S and increase the probability of Fitness for Purpose and project success, the above can be turned into a list of recommendations. Maguire reported such a list, the QinetiQ 'Ten Commandments of M&S', see Table 7-4, and this is recommended to the reader. [15]

**Table 7-4: Ten Commandments of M&S.**

1	Understand the purpose of your model or simulation and re-check it often.
2	Train your people to the most appropriate level for their tasking.
3	Keep records of who did what and when.
4	Record your assumptions about reality and your model and simulation during its development.
5	Review the validity of your assumptions as development and use progresses.
6	Ensure data sets are valid, including input sets, testing sets and mathematical constants.
7	Carry out as much Validation and Verification as necessary.
8	Obtain independent checking and peer review of your work (if appropriate).
9	Collect, manage and maintain your evidence in a structured way.
10	Record system development in a Credibility Workbook.

The utility of M&S and SE to the EW T&E process can be greatly assisted by following best practice processes, such as those in the previous section, and being ever mindful of the above problem avoidance measures.

## 7.9 NATO MODELLING AND SIMULATION GROUP

### 7.9.1 Introduction

NATO RTO has a M&S Group, the NMSG, who are custodians of a wealth of information on the topic of M&S. The mission of the NMSG is to promote co-operation among Alliance bodies, NATO Member

Nations and Partners for Peace Nations to maximise the effective utilisation of M&S. They organise Symposia, Specialists Meetings, Workshops and Lecture Series on various aspects of M&S.

The interested reader is strongly recommended to visit their internet site at:

<http://www.rta.nato.int/panel.asp?panel=MSG>.

The remainder of this section provides top-level information on the NMSG from the above site.

### **7.9.2 NATO HLA Compliance Certification**

The High Level Architecture (HLA) is the preferred Simulation Interoperability Standard recognised by NATO as early as 1998. HLA is an international standard as defined in IEEE and also STANAG 4603. To support proper use of HLA, the NMSG has established an HLA Compliance Certification Capability. This capability is distributed between NATO/PfP Nations and offered as a not for profit service to verify the capabilities of models and simulations relevant to being technically compliant with the HLA standard.

### **7.9.3 NATO Simulation Resource Library**

The NATO Simulation Resource Library (NSRL) is a development tool provided by the NMSG and RTA to increase the reusability level of the simulation resources within the RTO community – registration via RTO Web Site.

### **7.9.4 NATO M&S Standards Sub-Group: MS3**

The NMSG Sub-Group MS3 finalised the first edition of the Allied Publication entitled NATO M&S Standards Profile (NMSSP), AMSP-01. [16] This publication provides a comprehensive set of Standards that are applicable in the NATO M&S domain. The document was promulgated by the Director of NATO Standardisation Agency and is included in the NATO Standardisation Documentation Database.

The NMSSP aims to provide guidance to NATO and partner Nations, as well as national and NATO organisations who have requirements to effectively use M&S in support of NATO coalition and national requirements. It maintains information on M&S standards and recommended practices relevant to achieving M&S interoperability and re-use of M&S components, e.g., data, models. It provides a set of standards descriptions for decision making on options for the use of M&S standards for NATO activities, e.g., coalition training and experimentation.

## **7.10 INCREASED USE OF M&S THROUGH-LIFE**

As noted in Chapter 6 and in this chapter's introduction, there is significant potential for greater use of M&S in the EW T&E process. Given the strides made to date in M&S and in the underpinning computing power increases of the last decade, this potential extends to cover the through-life case for EW and other systems. This potential for increased utility is depicted in Figure 7-5. Validated M&S, when used appropriately, can lead to reduced programme risk, schedule and cost.

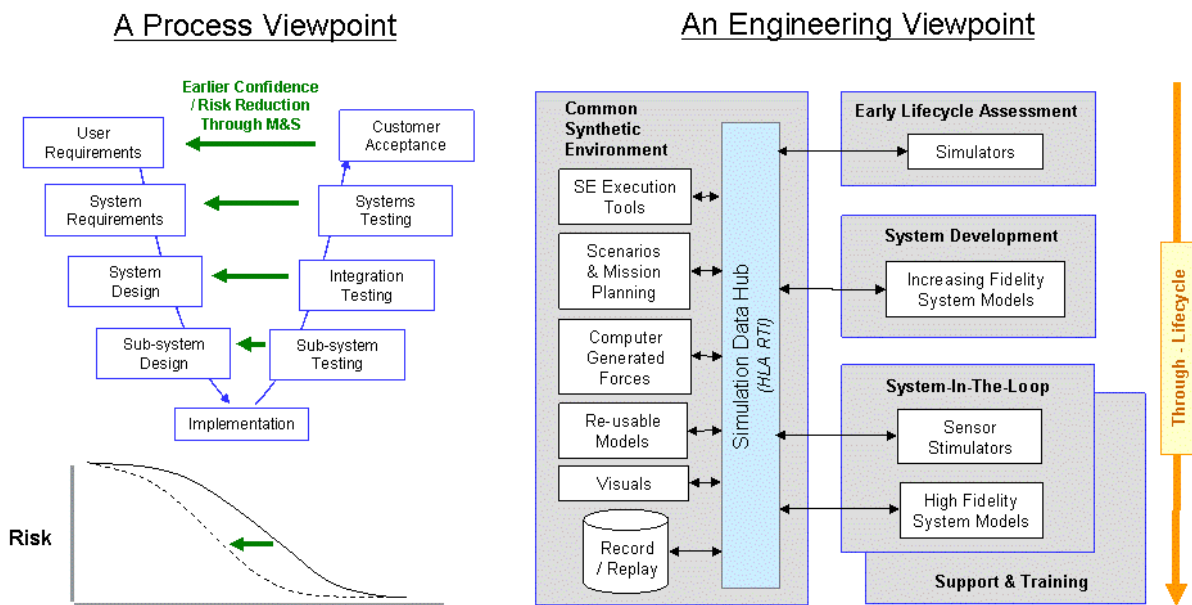

Figure 7-5: Increased Use of M&S Through-Life.

## 7.11 REFERENCES

- [1] Box, G.E.P. and Draper, N.R. (1987). Empirical Model-Building and Response Surfaces, p. 424, Wiley. ISBN 0471810339.
- [2] UK Defence Industrial Strategy. Defence White Paper, CM 6697, 15 December 2005.
- [3] UK Defence Technology Strategy for the demands of the 21<sup>st</sup> century, October 2006.
- [4] USA. Department of Defence (2007) Modeling and Simulation (M&S) Management. DoD Directive 5000.59. [Online]. Available at: <http://www.dtic.mil/whs/directives/corres/pdf/500059p.pdf> (Accessed: 11 May 2011).
- [5] MoD Acquisition Operating Framework. [Online]. Available at <http://www.aof.mod.uk/index.htm> (Accessed 11 May 2011).
- [6] Air Force Instruction 99-103, Change 2, 20 March 2009. Capabilities-Based Test and Evaluation. [Online]. Available at: <http://www.af.mil/shared/media/epubs/AFI99-103.pdf> (Accessed: 11 May 2011).
- [7] DEF STAN 03-44: 'A generic process for the Verification and Validation of Modelling and Simulation and Synthetic Environment systems', 31 March 2008.
- [8] MoD AOF: Common Terms used in Modelling and Simulation (M&S). Available via Internet: [http://www.aof.mod.uk/aofcontent/tactical/mands/content/terms\\_definitions.htm](http://www.aof.mod.uk/aofcontent/tactical/mands/content/terms_definitions.htm) (registration required for internet access.) Last accessed: 7 October 2011.
- [9] Pywell, M. Developments in RF simulator technology – approaching the affordable fidelity limit. The Aeronautical Journal, Vol.111, No.1123, September 2007.



- [10] Navy Modeling and Simulation Management Office: Department of the Navy – Modeling and Simulation Verification, Validation, and Accreditation Implementation Handbook. Vol. I – VV&A Framework, March 2004.
- [11] VV&A Recommended Practices Guide Special Topic: Fidelity, US DoD Defence Simulation and Modeling Office, 30 September 2000.
- [12] Grenier, D.P. Recommendations Regarding Initial Guidelines for the Minimum Requirements Necessary for System Representations Used in the Joint Mission Environment (JME1). Live-Virtual Constructive Conference, 12-15 January 2009, El Paso, TX, USA.
- [13] IEEE 1516.3-2003: Recommended Practice for High Level Architecture (HLA) Federation Development and Execution Process (FEDEP). [Superseded by IEEE 1730-2010]
- [14] IEEE 1730-2010: Recommended Practice for Distributed Simulation Engineering and Execution Process (DSEEP).
- [15] Maguire, R. Ten Commandments for Modelling and Simulation Fitness for Purpose. Paper presented at the RTO NMSG Conference on “Future Modelling and Simulation Challenges”, held in Breda, Netherlands, 12-14 November 2001, and published in RTO-MP-073.
- [16] Allied M&S Publications, AMSP-01(A): NATO Modelling and Simulation Standards Profile. December 2009. [On line]. Available at: <http://www.nato.int/cps/en/natolive/stanag.htm> (Accessed: 11 May 2011).

## **7.12 FURTHER READING**

Adamy, D.L. Introduction to Electronic Warfare Modeling and Simulation. SciTech Publishing: North Carolina, 2006.

East, P. Microwave Design Tools and EW Applications. 2<sup>nd</sup> Ed. Artech House Publications: Massachusetts, 2008.

Eberl, E.G. RF Threat Simulation for a Digital World. 34<sup>th</sup> Annual Dixie Crow Symp., EW Transformation, New Technology for Operational Systems. 22-26 March 2009, Warner Robins AFB, GA, USA.

Encyclopedia of Aerospace Engineering. Edited by Richard Blockley and Wei Shyy. John Wiley & Sons, Ltd. ISBN: 978-0-470-75440-5, October 2010. Volume 7, Chapter 376: Electronic Warfare and Defensive Aids System Design and Development, by M. Pywell.

Schleher, D.C. Electronic Warfare in the Information Age. (1999) ISBN 0-89006-526-8. Appendix A: Radar Jamming Modeling and Analysis Tool.



## Chapter 8 – EW FLIGHT TEST PLANNING, EXECUTION, AND OPERATIONS

### 8.1 INTRODUCTION

Other chapters of this Handbook addressed the technical considerations of EW T&E. This chapter deals with EW flight test execution and operations focusing on large OAR missions; however, many of the underlying principles also apply to other EW flight test operations as well as ground and laboratory testing.

EW flight test missions are complex, expensive, and frequently utilise scarce or shared resources. Disciplined test execution is necessary for test mission success. Test planning should be completed well in advance of the required need date to ensure all technical details are addressed, the required resources will be available, and test methods are applicable and sufficient to evaluate test objectives.

Flight test missions often involve coordinating the activities of multiple aircraft, threat simulators, and dozens of people in multiple locations. Each participant must understand others' roles and responsibilities, as well as their own. Data analysts must also thoroughly comprehend the data acquisition and reduction processes for each data source they will encounter.

### 8.2 TEST PLANNING

Sound test planning is essential to successful test execution. A test plan documents the detailed objectives, MOPs, data requirements, evaluation criteria, success criteria, test procedures, constraints and limitations. The Data Analysis Plan (DAP) details how the collected data will be reduced, processed, analysed, and used to calculate the MOPs. Detailed documentation is important to make certain that test procedures are repeatable and to smooth transitions during personnel changes.

All test plans should be reviewed by qualified engineering and aircrew personnel for technical accuracy. To aid objectivity and completeness, the reviewers should not be affiliated with the test. Test plans should also be reviewed from a safety perspective by similarly unaffiliated parties. Test plans should typically be approved at least 30 days before the first flight, although this may vary by test organisation.

The test team provides a Programme Introduction Document (PID) to the OAR. The PID describes the purpose and scope of the test programme, and documents the expected resource requirements. The test team should normally provide a PID to the OAR at least six months prior to the expected first flight. More complex efforts may require 12 months or longer lead time. The OAR will then respond to the PID with a Statement Of Capability (SOC) detailing the support the OAR can provide, as well as cost and schedule information. Close coordination between the test team and the OAR throughout the PID/SOC development process minimises risk and uncertainty, and ensures all issues and potential problems are thoroughly understood and vetted.

An important purpose of advanced coordination and planning with the OAR is to allow time for the test team to become completely familiar with the test range. Personnel must understand how the threat simulators operate, how they are instrumented, what the available data products and their sources are, and how the OAR communications systems operate.

Some common factors that must be considered in EW flight test planning are:

- **Flight Profiles** – A test plan should document the flight test profiles in such a way that the reader can understand the methodology underlying the profile, i.e., a knowledgeable reader should be able to relate the profile to the data being collected, the MOPs being calculated, and the objectives

being evaluated. If the test range is known, the profile can be drawn very specifically with waypoints identified and altitudes and airspeeds specified. It is important to correctly identify tolerances for specified parameters, such as airspeed and altitude. Tolerances that are too tight reduce flexibility making execution difficult, while tolerances that are too loose risk inability to meet the objective.

- **Airspace Restrictions** – The test team needs to work with OAR personnel to tailor the test profiles to conform to airspace restrictions. Normally, airspace above the OAR’s land range boundaries is restricted and can be dedicated to the test mission if required. However, test requirements frequently necessitate operations outside of restricted airspace. These operations must be coordinated well ahead of time to ensure all test requirements can be met and that objectives or procedures can be modified to accommodate any constraints. Supersonic flight operations and low altitude operations (typically below 500 feet AGL) may also require special coordination.
- **Rules of Engagement** – ROE describe how the ground-based and airborne threat simulators will operate during the test mission. Modern radar systems are extremely complicated and have a variety of operating modes and EP features. It is important to document and communicate what restrictions will be placed on threat simulator operators and the rationale for the ROE. Poorly documented and communicated ROE are a common reason for failing to meet test objectives.
- **Radio Frequency Transmission Coordination** – Radio frequency transmissions from test and support aircraft can disrupt civil and commercial communication and must be coordinated with the OAR’s frequency managers. The frequency spectrum and type of transmissions such as noise or false target EA techniques must be identified. Some types of transmissions may generate geographic, altitude, or time-of-day restrictions.
- **Expendable Countermeasures (EXCM) Separation** – EXCM such as chaff, flares, and towed decoys require advanced coordination. Chaff is designed to disrupt hostile radars and can also affect civilian air traffic control radars. Chaff clouds can persist for a long time and can also be carried by the wind. Flares pose a fire hazard when dispensed at low altitude. Towed decoys typically weigh several pounds and can pose a risk to ground-based personnel and facilities if an inadvertent separation occurs. Test planning must consider where the towed decoy operations will occur to avoid over-flying manned sites or high value assets.
- **Support Aircraft** – Several types of support aircraft are often employed in EW testing. Airborne threat surrogates function similarly to ground-based threat simulators by resembling hostile airborne weapons systems. Safety chase aircraft may be required for some operations, particularly those involving EXCM separation for new systems. Specialised aircraft can perform signature and other measurements of the test aircraft, such as IR radiometric measurements. Refuelling tankers can increase test efficiency by extending a test aircraft’s time on range.
- **Data Products** – Early coordination with OAR data analysts can greatly reduce post-mission data analysis turnaround times. Early coordination ensures that the test team’s data analysis tools are compatible with the OAR data products, either by specifying data format requirements with the OAR or by modifying the analysis tools to make them compatible. Processing sample data products from the OAR before testing begins is an excellent risk mitigation procedure.

### **8.3 FLIGHT TEST EXECUTION**

Successful EW T&E test mission execution on OARs requires the disciplined, concerted efforts of numerous people in multiple locations. Accurate and concise documentation for all participants is essential to effective test mission execution. Test planners must understand the roles and responsibilities of the various participants to ensure efficient and effective test execution.

### **8.3.1 Mission Execution Documentation**

The test plan and DAP provide a comprehensive description of the overall test effort. A sufficiently detailed test plan supports the creation of flight and test mission cards that are thorough, yet concise, organised, and targeted to specific readers. The importance of well-written flight and test mission cards cannot be overstated, as they can mean the difference between mission success and failure.

Flight cards provide aircrews with all of the necessary information about each test point. At a minimum flight cards should contain:

- OAR entry and exit procedures;
- Radio frequencies and call signs;
- Test point numbers;
- Test profile diagrams with waypoints and airspace limitations;
- Altitudes and airspeeds with tolerances;
- Manoeuvre information; and
- SUT configuration details and operating procedures.

Pilots and other aircrew members operate in a high-workload environment and in tight quarters; they need complete information formatted for the quickest reading. Superfluous details, extraneous words and inconsistent styles can cause delays or confusion with detrimental results. During a typical RWR test, for example, the test conductor, SUT analysts, and threat simulator radar operators must know the threat simulator modes, such as frequency, PRI, or scan type. This information is generally unnecessary to the pilot and therefore should be omitted from flight cards.

The Test Director (TD), Test Conductor (TC), system analysts, and threat system operators should have mission cards containing the details required to execute each test point. Events happen quickly in a flight test mission. Just as with flight cards, mission cards should be succinct, well-organised and contain only vital information. For a given test point, the threat simulator operators need to know the ROE for target engagement and how to configure their radars so this information should be included on their mission cards. If they do not need to know how the SUT is configured, then SUT configuration details should not be on their mission cards.

Additional SUT and flight test documentation such as the test plan, safety procedures, flight manuals, etc., should be available in the mission control room for SUT troubleshooting or emergencies.

### **8.3.2 Test Mission Participants and Conduct**

Figure 8-1 illustrates the participants and their interaction in a typical EW OAR flight test.



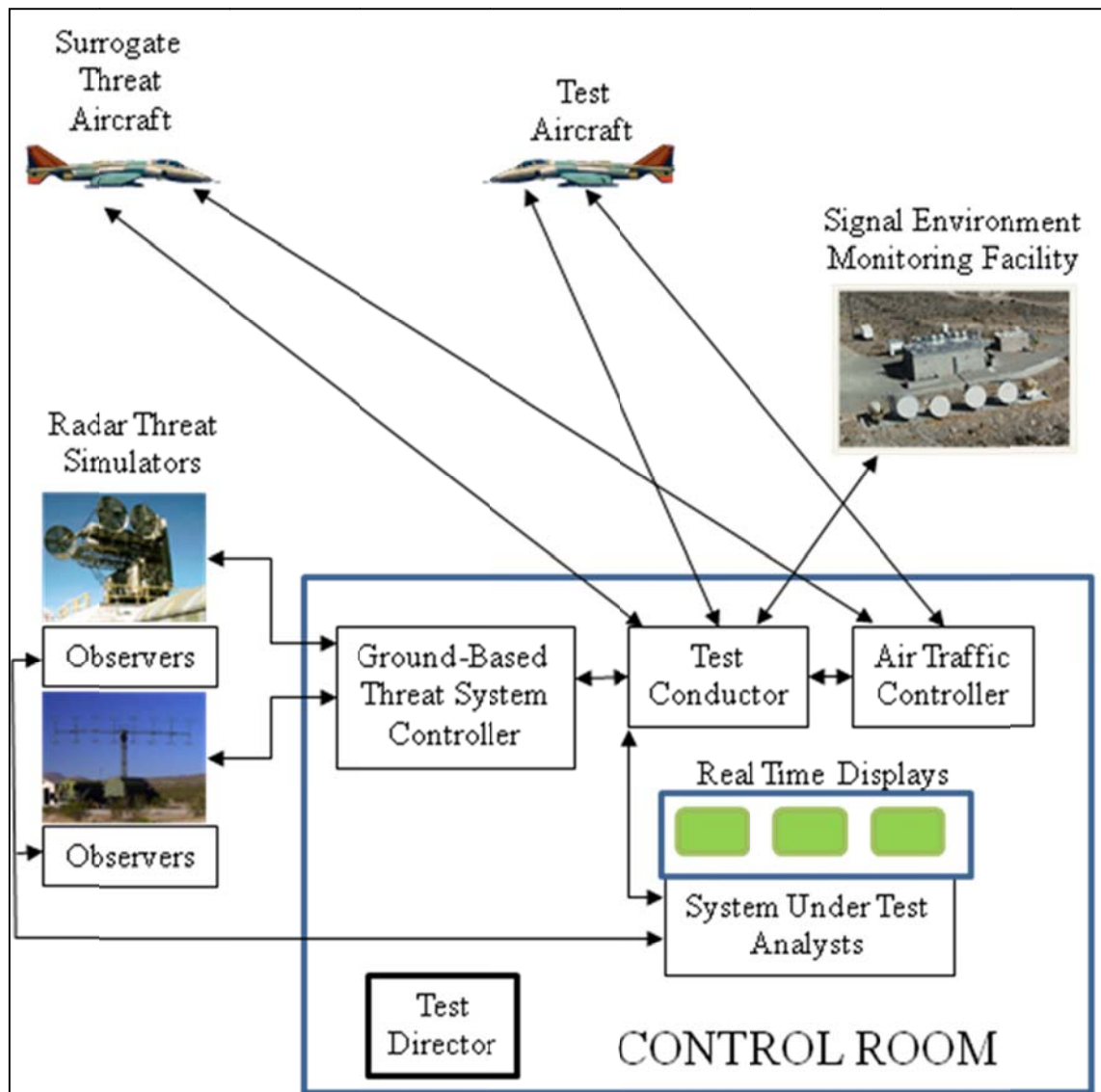

Figure 8-1: Typical EW OAR Mission Participants.

- Test Director** – The TD has overall responsibility for a test mission. The TD is ultimately responsible for safe and efficient mission execution and generally does not get involved in the details of the test point-by-test point conduct of a test mission. The TD must maintain a separation from the mission details to ensure the mission is conducted safely and avoid becoming fixated on the mission details and losing overall perspective. The TD needs to have substantial aircraft and sub-systems knowledge to assist the aircrew in the event of an emergency. The TD also makes real-time decisions when there are planned or unplanned mission changes that could affect mission success or test point completion.
- Test Conductor** – The TC coordinates the step-by-step execution of each test point as documented on the test cards. For safety reasons, the TC has limited discretion to deviate from the approved test procedures documented on the test cards. The TC ensures that all active participants (the test aircrew and air traffic controllers, threat system controllers, and analysts) are ready to perform the

duties associated with the current test plan. In test missions with multi-position aircraft, particularly those with complex EW suites, an airborne test conductor can coordinate the activity within the aircraft. However, an airborne TC should always take mission direction from the TC in the control room, who will always have the most complete knowledge of the overall mission situation, particularly the operational status of the threat simulator systems and their availability to participate on a given test point.

- **SUT Analysts** – The engineers and analysts are experts on the SUT and its performance. They monitor the real-time SUT data as well as data from the threat simulator systems. When the SUT is not operating as expected, these experts advise the TD and the TC regarding how or whether the mission should continue.
- **Ground-Based Threat System Controller** – The ground-based threat system controller communicates the details of each test point to the threat simulator operators who will be participating on a given test point. Typical information details include frequencies, PRIs, modes, and ROE. The ground-based threat system controller also communicates information about threat system maintenance status to the TC and the system analysts, which allows them to react to changes in threat system availability.
- **Air Traffic Controller** – The air traffic controller directs the activity of airborne assets including test aircraft carrying the SUT (or SUTs) and surrogate threat aircraft. The air traffic controller also coordinates the test aircraft range entry and egress process, and handles other air space coordination issues.
- **Test Aircraft Aircrew** – The aircrew fly the test aircraft and operate the SUT(s) and onboard instrumentation. They operate under the direction of the TC and/or the air traffic controller. In multi-crew member aircraft, mission support aircrew can monitor onboard instrumentation systems and provide additional information to system analysts in the control room beyond what telemetry data provide.
- **Test Support Aircrew** – The test support aircrew operate airborne threat surrogate aircraft or airborne measurement aircraft under the direction of the TC and/or the air traffic controller.
- **Signal Environment Monitoring Facility** – The signal environment monitoring facility provides an important resource to analysts during the mission. The facility can monitor threat simulator outputs and the transmissions generated by the SUT(s), including ECM signals. It also monitors the environment for signals that are not part of the test setup, as extraneous signals can interfere with the performance of the SUT.
- **Threat System Observers** – The threat system observers supply information about the effectiveness of a given ECM technique. Many ECM techniques are visually subtle; a knowledgeable observer at a threat site with the radar operators can be an invaluable source of information. Observers need to be familiar with the specific threat system they will be observing, as well as the ECM technique design and its intended effect(s).

## **8.4 OAR DATA COLLECTION**

The purpose of a flight test is to collect data, which is used to calculate MOPs for test objective evaluation. The flight test team must understand what data are available and how the data will be obtained and processed. Figure 8-2 illustrates the various data sources and how they are collected.

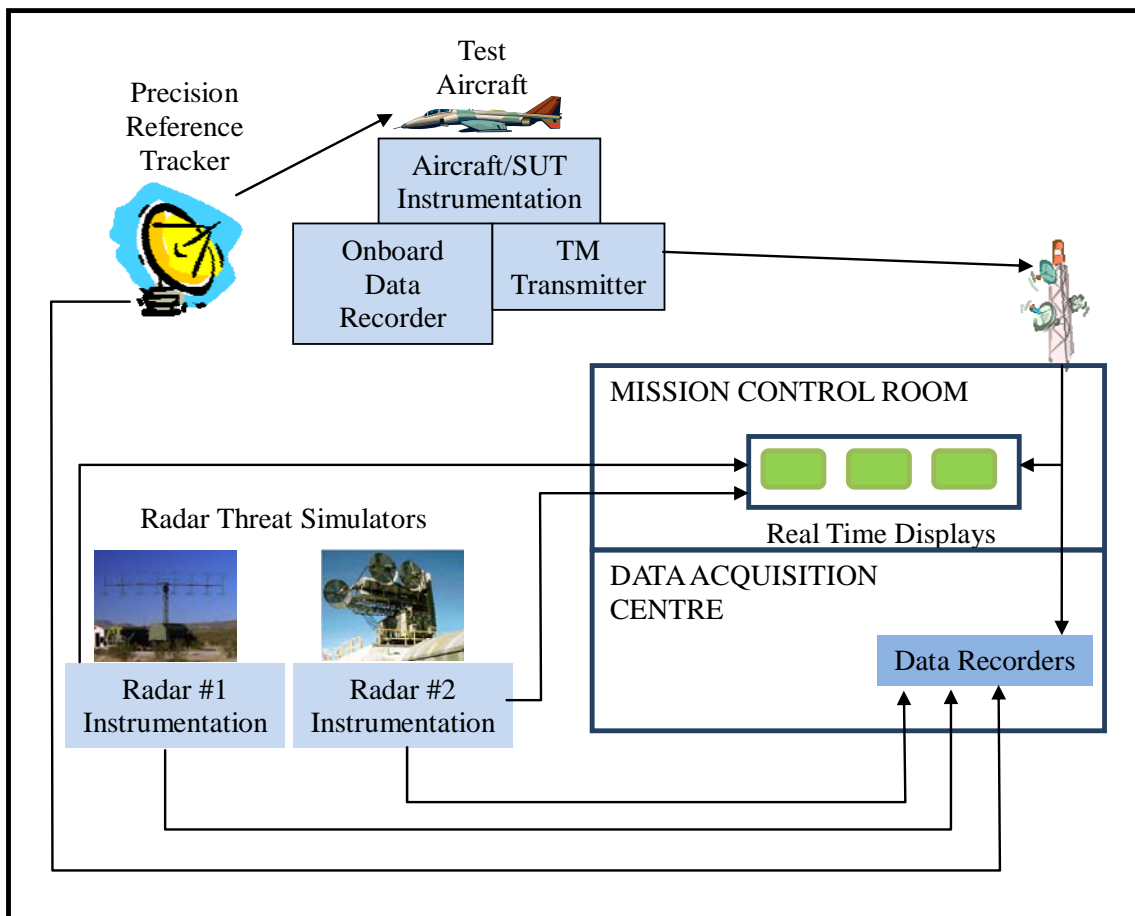

Figure 8-2: EW OAR Test Mission Data Sources and Routing.

There are three primary points of data collection:

- **Test Aircraft** – The SUT(s) will generally have onboard data recorders to capture, store and transmit time-encoded critical test data. Certain aircraft parameters, such as position and attitude, are frequently recorded as well. Modern data recorders are normally solid state devices, although magnetic tape recorders are still common. Video capture devices record the aircraft displays, directly where possible. Telemetry (TM) allows selected critical parameters to be transmitted from the test aircraft for real-time processing and display to analysts in the control room. TM provides analysts with instantaneous data to determine if the system under test is operating as expected.
- **Threat Simulator** – Instrumentation is largely system specific, and should be researched and understood by the data analysts. Common parameters are: system on time, system off time, operating frequency, PRI, and EP modes. These parameters are commonly extracted from the system, time encoded and transmitted to a data acquisition centre where they are recorded. The OAR personnel will normally work with customers to provide data in customer-specified formats and media. During flight testing, video and certain parameters can be extracted and provided to SUT analysts in the control room to support real-time analysis.
- **Precision Reference Tracker** – Precision reference radar trackers are less important than they were in the past due to the increasing availability of GPS-based TSPI sources, although they still are generally available and have applications. A variety of radar types provide TSPI for aircraft. Each OAR can provide information about the radar types they employ. Radar beacon transponders can greatly enhance TSPI radar accuracy.

## Chapter 9 – LEARNING FROM EXPERIENCE

### 9.1 INTRODUCTION

This chapter gives examples of problems encountered during T&E of EW and related avionics systems over more than three decades. For each problem a root cause analysis enabled identification of one or more learning points. With the benefit of experience, most problems that were noted are now avoidable. The EW T&E practitioner wastes less time, effort and money by anticipating and avoiding past problems. This improved efficiency is essential to the T&E process, particularly in an uncertain economic environment.

### 9.2 BACKGROUND AND OTHER SOURCES OF LESSONS LEARNED

Berkowitz, in his paper *EW Testing Lessons Learned*, summarised points with which the authors of this updated AGARDograph fully concur:

‘Electronic Warfare testing provides many challenges and is fraught with dangerous problems. Fortunately, many problems can be anticipated and avoided. [The] secret to EW testing is “Plan, Plan, Plan ...” Yet despite the best laid plans, there will be problems ... that is guaranteed. However, with foresight and planning, at least they won’t be the same old familiar problems.’ [1]

This chapter, in common with similar ‘lessons learned’ publications, actually gives ‘lessons identified’ – better described as ‘learning points’ – rather than ‘lessons learned’. A lesson cannot accurately be described as ‘learned’ until the required action is taken to prevent the problem’s recurrence. This subtle distinction is important to note; unfortunately, experience has shown that it is difficult to achieve lessons learned.

Against this background, this chapter aims to provide novice, experienced and expert EW T&E engineers and programme managers with problem recurrence prevention knowledge to help minimise cost, time, effort and risk on future EW trials on all types of T&E facilities. This knowledge has been gleaned from many contributors, who together have hundreds of years of T&E experience on a multitude of EW systems, on many platform types, and in a number of NATO Nations.

The examples that follow have been collected directly from test engineers in the field. They provide useful insight to the types of failures or anomalies that have been frequently experienced in the course of testing. While some examples are very specific and might seem too unique to be of any help, they are presented here to illustrate the broad range of problems that may occur.

Further examples of learning points are contained in Berkowitz’s *EW Testing Lessons Learned* and Stadler’s *Test and Evaluation Lessons Learned from the Field*. Although these examples are not repeated in this chapter, they contain much useful information for the EW programme manager, test planner and test engineer alike, and their study is recommended. [1],[2]

Readers are invited to add to this knowledge base, for inclusion in this Handbook’s next update, by contributing EW T&E lessons learned. Contact information can be found on Page xxvii.

### 9.3 LEARNING POINTS IDENTIFIED

The following notes apply to the lessons and learning points identified in this chapter.

- All lessons identified in this chapter are offered by the contributors without prejudice, liability or commitment. They are provided in good faith to help reduce the time, cost and risk of EW T&E across NATO and its partner Nations.

## LEARNING FROM EXPERIENCE

---

- The learning points:
  - Are presented in no particular order or priority.
  - Supplement the commentary within Chapter 6 on the strengths and limitations of various types of T&E facilities.
  - Have had most references to specific programmes, projects, platforms, equipment and persons removed.
- The problems and learning points resulted from T&E at various stages of the SUT life cycle, from R&D through D&D to DT&E/OT&E and in-service use. They have resulted from T&E of EW equipment in isolation, from sub-system (Defensive Aids Suite) integration activities, and from systems integration activities and platform-level T&E on the ground and in flight.
- Most lessons, although originating from air platform EW T&E, are considered equally applicable to EW T&E for land and sea platforms.
- Many learning points identified yield suggestions to the EW SUT and air platform specifiers and designers on how to ensure repetition of the problem is prevented.



**Table 9-1: Lessons Learned – An Aid to Problem Recurrence Prevention.**

<b>TOPIC AREA</b>	<b>PROBLEM, ROOT CAUSE AND COMMENT</b>	<b>LEARNING POINT</b>
<p>Know the expected results</p>	<p>During planning for tests, you should identify the expected test results so any differences are readily recognised and, if necessary, more data can be taken. Generally, it is too late after tests are conducted and data are analysed to try to get additional information about a failure. It is good to prepare blank data sheets ahead of time and perhaps make a mental or dry run, as may have been done during college physics laboratory, so critical laboratory test time and/or assets are not wasted. An example is given below.</p> <p>When out-of-band frequency measurements were made on a jammer’s transmission signal, spurious signals at low frequencies with powers exceeding those allowed by the specification were detected. These measurements were discounted since only very low level signals were expected because the band being measured had a waveguide output, which acted as an excellent high pass filter. The tests were repeated with a Low Pass Filter (LPF) inserted, and the spurious signals disappeared. The LPF attenuated the strong in-band signal which was saturating the spectrum analyser. If the expected results were not postulated, extensive measurements would have been recorded on the phantom signals and it may have been erroneously reported that the jammer design didn’t meet specification.</p> <p>Whilst applicable to most avionics T&amp;E, this risk of wasted time and effort is especially so for EW systems, in particular for RWR/ESM-to jammer tests, where the final test result is often not known until post-test analysis has been completed. A problem discovered then often means a full re-run of the test and analysis.</p>	<p>Test time and effort can be wasted if the tester does not have a good idea of what the test result should be.</p> <p>Two items are particularly helpful in reducing T&amp;E time, cost and risk:</p> <ul style="list-style-type: none"> <li>• Pre-test prediction of acceptable results.</li> <li>• Use of Quick Look-See features in test equipment, e.g., QLS in the Northrop Grumman Amherst Systems’ ECM Signal Measurement System. This allows problems to be picked up at the time of the test, enabling further and/or investigative measurements to be quickly taken.</li> </ul>
<p>Know and understand Interface Control Documents</p>	<p>The root cause of a number of problems encountered during EW T&amp;E have been attributed ICDs. Problem recurrence could be prevented if the following clarifications were added to ICDs:</p> <ul style="list-style-type: none"> <li>• Tolerances on leading/trailing edges and widths of digital pulses, especially on blanker (suppression management) systems.</li> <li>• Precise specification of connector type, shell orientation and pins/sockets for equipment and aircraft connector.</li> <li>• Precise identification marking on aircraft connectors/cables and equipment boxes.</li> </ul>	<p>Test engineers need not only to have an intimate knowledge of the specification of the EW SUT(s) they are about to test, but also they need to know and understand the ICD(s) that govern the interconnectivity between the SUT(s) and other avionics and other equipment to which it connects.</p>

**LEARNING FROM EXPERIENCE**

<b>TOPIC AREA</b>	<b>PROBLEM, ROOT CAUSE AND COMMENT</b>	<b>LEARNING POINT</b>
<p>Know and understand Interface Control Documents (cont'd)</p>	<ul style="list-style-type: none"> <li>• Expansion/clarification to prevent problems that cannot be attributed to either ICD or specifications.</li> <li>• Formal review of ICDs are required whenever equipments are modified. Unplanned investigation and solution costs and time delays have been incurred where this has not been done.</li> <li>• Although it has been suggested that equipment specifications be refined to include a better definition of the on-board and external RF environment, there is a case to include this in ICDs. That is, treat the airframe and surrounding atmosphere as an 'interface' between RF transmitters and receivers.</li> </ul>	
<p>Aircraft ground trials problems resolved by use of anechoic chamber facilities</p>	<p>Most problems encountered on aircraft ground test on outside test sites can be prevented or mitigated by running those trials in the weather- and electromagnetically secure environment within anechoic chamber test facilities. Generic problems encountered that can benefit in this way include:</p> <ul style="list-style-type: none"> <li>• RF pollution/interference/security clearance for transmissions, with severe restrictions on the use of frequency agility and 'war' modes: severely limits scope, time and location of tests.</li> <li>• Weather limitations: Between technical (design and operation), natural (weather, environment and limited number of daylight hours) and logistical requirements (need for opening radome, bays and canopy) during such trials, a general observation by Trials Managers has been made that outdoor EW trials in winter should be avoided if possible. Investigations by one PSI have shown that over 15% of aircraft EW ground test programme time was typically lost to weather alone.</li> <li>• Reflections, especially from wet ground and nearby metalwork on radars/radios/ECM/RWR/ESM trials: <ul style="list-style-type: none"> <li>• Microwave and millimetre wave propagation is dependent on atmospheric conditions.</li> <li>• Multi-path effects and the very low grazing angles used with respect to the ground lead to distortion of results and a wholly unrealistic external environment around the aircraft, in many cases leading to problems seen on the ground but not repeatable in flight et vice versa.</li> </ul> </li> </ul>	<ul style="list-style-type: none"> <li>• Avoid executing aircraft ground trials on open air test sites during the winter months, to optimise test programme schedule, risk and cost.</li> <li>• Use anechoic chamber test facilities in preference to outside test sites for aircraft EW ground trials. This will aid minimise time and risk, and maximise the scope of tests possible.</li> </ul>

TOPIC AREA	PROBLEM, ROOT CAUSE AND COMMENT	LEARNING POINT
<p>Aircraft ground trials problems resolved by use of anechoic chamber facilities (cont'd)</p>	<ul style="list-style-type: none"> <li>• Furthermore, the uncontrolled nature of these reflective surfaces makes repeatability of test results almost impossible to attain. This is seen as the dominant factor in the overall poor quality of EW test results other than those in anechoic chambers and has led to the need for much repeat on-aircraft test work.</li> <li>• In many EW receiver cases much test effort has been wasted as a result of using an uncontrolled RF environment. Only an anechoic chamber can provide a suitably controlled environment.</li> </ul>	
<p>EW flight trials problems</p>	<p>A number of generic EW T&amp;E problems have been noted during flight trials, some of which are similar to those noted in this table regarding ground trials:</p> <ul style="list-style-type: none"> <li>• Weather: The impact on trials duration is generally worse than that noted above on ground trials.</li> <li>• Limited number of EW test ranges, and the limited RF emitter scenarios that can be generated (see also Chapter 6).</li> <li>• Logistical difficulties and cost of using airborne EW targets.</li> <li>• Security clearance for use of sensitive ECM/radar modes.</li> <li>• Poor instrumentation of EW systems.</li> <li>• Poorly documented and communicated Rules of Engagement for the operation of ground-based and airborne threat simulators during the test mission. One of the most common reasons for failing to meet test objectives.</li> </ul>	<ul style="list-style-type: none"> <li>• Wherever possible, move EW DT&amp;E/OT&amp;E work from flight to ground test, in anechoic chamber ISTFs, laboratories and via the use of suitably validated M&amp;S.</li> <li>• To minimise cost and time, limit EW flight test to those areas that can only be cleared by flight test.</li> </ul>
<p>Test engineer experience</p>	<p>A prior study showed the importance of having capable, experienced test engineers with a good appreciation of the 'real world' that the EW SUT is required and designed to work in. There is also a clear need for a 'wide-eyed' approach to rig testing. Here emphasis needs to be placed, within financial constraints, on examining system performance against the 'real world', rather than merely testing word for word against the requirements of the equipment specification.</p> <p>The benefits of using such engineers with that approach was seen by comparing the EW problem-finding ratio SIL-to-flight test for one platform variant vs. that of a different variant of the same</p>	<p>Use experienced RF and EW test engineers if a minimum risk, cost and duration rig and aircraft trials are required.</p>

**LEARNING FROM EXPERIENCE**



TOPIC AREA	PROBLEM, ROOT CAUSE AND COMMENT	LEARNING POINT
<p>Test engineer experience (cont'd)</p>	<p>platform. The SIL with the experienced RF and EW engineers found four times as many problems than the lesser experienced team on the second SIL, resulting in many less problems being left to be found during flight trials.</p> <p>The study also showed that there is a definite requirement for feed-forward of SIL test expertise to aircraft ground and flight test, in the form of systems ‘specialists’ who move with the SUT through its development life cycle. Failure to do this resulted in a large number of problems being re-found, re-investigated and re-raised as problem reports during the aircraft ground and flight test phases.</p>	
<p>Importance of formally reporting problems</p>	<p>Formal system/avionic problem reports are part of a closed-loop process that ensures problem fixes or adequate and acceptable explanations result. Unfortunately, these reports have not always been raised during EW/avionic trials on rigs, during aircraft ground test and flight test. Sometimes this has allowed real problem to get past DT&amp;E and OT&amp;E only to be then be reported from operational use by the air force(s) concerned. Some have even had adverse operational impact.</p> <p>The reasons for this are varied, with some examples here:</p> <ul style="list-style-type: none"> <li>• Test engineers do not recognise there is actually a problem present. This is most usually caused by either unfamiliarity with the SUT and its specification (see separate ‘Know your SUT’ lesson) or inexperience or a combination of these.</li> <li>• The problem is ‘covered’ in the test report for the trial concerned, but has then lain dormant and un-progressed for a considerable period of time or not followed up at all.</li> <li>• Reluctance to report problems from aircraft ground and flight test for fear of slowing, lengthening or having to stop the trial.</li> <li>• The view of some engineers that if a problem cannot be repeated it is therefore not a problem – see separate lesson learned on this topic.</li> <li>• Test engineer enthusiasm to “get on with testing”.</li> </ul>	<ul style="list-style-type: none"> <li>• Always raise system/avionic problems when something does not or does not appear to operate correctly. It will never get fixed if you don’t report it!</li> <li>• Even if the SUT meets its specification, if – as a professional engineer – you believe there is a problem that will adversely affect its successful operation by the end user, then raise a problem report.</li> <li>• In this way there can be a reasoned examination of whether the specification itself may have shortfalls or ambiguities – a common occurrence.</li> <li>• At best you will have prevented a problem being passed to the platform’s operational phase and optimised the time and cost of fixing it; at worst you will have spent a relatively small amount of time getting clarification of what the SUT should and should not do.</li> </ul>

<b>TOPIC AREA</b>	<b>PROBLEM, ROOT CAUSE AND COMMENT</b>	<b>LEARNING POINT</b>
<p>RF threat simulation capability and use</p>	<p>Many problems encountered during T&amp;E of EW receiver systems (RWR/ESM/ECM) have been traced to inadequacy of, or problems with the use of RF threat simulators. Points of note are:</p> <ul style="list-style-type: none"> <li>• Test engineers should check that emitter data programmed into the threat simulator is compatible with that programmed into Mission Data in the EW SUT. Much time has been wasted due to data/database errors and differences between these or between one or both of these and the parameters of the real threat emitter.</li> <li>• To maximise the potential for conducting as much of RF EW system testing on sub-system and systems integration rigs rather than on aircraft, a fairly substantial RF threat simulation capability is required. The ‘rule of thumb’ 1.0 Mega-Pulses Per Second capability, whilst adequate for testing some RWR systems, is considered less than adequate for modern ESM.</li> <li>• Unless the threat simulator has intra-pulse high fidelity modulation (pulse shaping) capability, the test engineer should remember that simulators generate signals that can have considerable differences to the real-world emitters they are simulating. Consequently, EW SUTs may react differently in the rig/chamber environment to how they will on an open air range against a real threat emitter.</li> <li>• Emitter and scenario construction and validation prior to use in T&amp;E is complex and can be prone to human error. Appropriately thorough checking is essential to prevent problems. The use of emitter validation tools such as the Northrop Grumman Amherst Systems Inc. Environment Graphical Analysis (EGA) tool can help the test engineer visualise what is happening in the scenario with time and does not tie up the threat simulator whilst the emitter and scenario construction and validation takes place. Such tools also allow the T&amp;E engineer to double check that the test scenario being constructed can actually be catered for by the digital and RF resources of the threat simulator. Without this level of care in the construction and use of threat simulators it can be very difficult to see, investigate and resolve a problem. Indeed, it is wise, when using complex RF scenarios, to examine both the SUT and the test set-up when a problem is first encountered.</li> </ul>	<p>T&amp;E engineers need to understand the capabilities and limitations of the RF and other threat simulators they use. These are highly specialised items of test equipment and specialist advice should be sought as necessary.</p>

**LEARNING FROM EXPERIENCE**



TOPIC AREA	PROBLEM, ROOT CAUSE AND COMMENT	LEARNING POINT
<p>On-board and external RF environment</p>	<p>Some of the more subtle, problematic and operationally serious problems encountered concern the performance of RF EW systems when exposed to the on-board and/or external RF environments, including the formation flying case. This item can be broken down into two aspects:</p> <ul style="list-style-type: none"> <li>• EMC of the EW systems themselves: To assure problem-free operation the EMC specification of the EW equipment must adequately cover the operational air RF environment the platform has to operate in. This is not always adequately covered by standard EMC qualification tests and unexpected problems have been experienced during aircraft ground and flight test.</li> <li>• The performance of RWR/ESM/ECM systems in the presence of a given external RF environment: In this case, receiver front-end overload has been seen on a number of occasions. How this manifests itself and the immediate and subsequent warnings to aircrew of system performance degradation have been the subject of a number of problem reports.</li> </ul>	<ul style="list-style-type: none"> <li>• Develop an accurate definition of the operational air RF environment the SUT has to operate in. This needs to include formation flying aircraft RF emitters, the on-board RF environment, reflections of own emitters from the ground and other aircraft, surface/sea emitters and other airborne RF sources.</li> <li>• Use M&amp;S tools to develop robust predictions of this environment where measured power density profiles are not available.</li> <li>• Provide the RF EW equipment supplier with an accurate picture of the total air RF environment.</li> </ul>
<p>RF inter-operability, antenna coupling and RF compatibility</p>	<p>Confusion about the specific meaning of the terms ‘RF Interoperability’ and ‘RF compatibility’ in aircraft EW ground trials has led to duplication of on-aircraft test work under the guise of first EW performance verification, and then EMC clearance of platform. Whilst the definitions vary across Nations and their agencies, a common view is:</p> <ul style="list-style-type: none"> <li>• <b>Interoperability tests</b> involve the EW systems’ antennas with the receivers and the rest of the RF EW system connected. It addresses how RWR/ESM/ECM equipments perform when subjected to the actual RF environment generated by one or a combination of other transmitters on the host aircraft. Encompassed in this is demonstration of adequate RF suppression management to ensure that RWR/ESM/ECM systems can perform their respective tasks adequately.</li> <li>• <b>Antenna coupling</b>, which has by far been one of the biggest problem areas during EW systems integration on military air platforms, is a function of the transmit/receive antennas, their installation, the airframe and the RF power density generated by each transmitting antenna.</li> </ul>	<p>Ensure an all-party understanding exists of these terms at the outset and thus tailor test programme to minimise duplication.</p>



TOPIC AREA	PROBLEM, ROOT CAUSE AND COMMENT	LEARNING POINT
RF inter-operability, antenna coupling and RF compatibility (cont'd)	<p>It involves the determination of installed antenna polar diagrams and the quantification of energy coupling between antennas or groups of antennas anywhere on the aircraft. This coupling is to be determined for all stores configurations to be used, especially where large reflective surfaces are added, e.g., external fuel tanks. The coupling can be measured by connecting a suitable RF signal generator/amplifier to the transmitting antenna and a spectrum analyser to the receiving antenna. Antenna coupling is essentially an EMC test and numerous examples have been seen over the years. Antenna coupling power measurements can be used by EW/radar/radio equipment manufacturers to optimise receiver performance and suppression management strategies.</p> <ul style="list-style-type: none"> <li>• <b>RF Compatibility Matrix demonstration</b> is an EMC test and comprises the operation of each aircraft transmitter singly and in combination, whilst monitoring for any interference caused to the aircraft's receivers.</li> </ul>	
RF inter-operability of installed radar and RWR	<p>When carrying out flight testing shortly before a new RWR capability was due to be cleared for operational use, it was found that when the FCR was in certain frequency agile modes, the RWR intermittently displayed false threats at around 7 o'clock. The Government Customer had placed 3 separate contracts for the systems involved:</p> <ul style="list-style-type: none"> <li>• Government Furnished Equipment (GFE) contract for the radar from a system supplier.</li> <li>• GFE contract for the RWR from a different division of the same system supplier.</li> <li>• System installation by the fighter aircraft company.</li> </ul> <p>For "need to know" reasons, the engineers in the aircraft company and in the RWR division had not been given the details of certain FCR modes. When the problem was pinpointed to the interaction between the FCR and the RWR, the Customer was frustrated that none of the 3 companies/divisions involved would accept liability (i.e., pay for) fixing the problem, despite high level pressure from the Customer. Owing to operational urgency, the RWR was accepted for entry to service with a known problem that took a considerable amount of time and effort (commercial and engineering) to fix retrospectively.</p>	<ul style="list-style-type: none"> <li>• Ensure that someone has clear contractual responsibility for platform system integration, including RF Interoperability.</li> <li>• Ensure that the engineers involved in designing and testing the RF Interoperability of the installed systems are recognised as having a "need to know" for the detailed transmit characteristics of all of the radar modes to be used operationally.</li> <li>• Conduct installed RF interoperability testing of classified modes in an anechoic chamber as early as practical in the project.</li> </ul>

**LEARNING FROM EXPERIENCE**



TOPIC AREA	PROBLEM, ROOT CAUSE AND COMMENT	LEARNING POINT
<p>Ensure EW SUT serviceability prior to test commencement</p>	<p>Always run a complete I-level repair test on the SUT (including sensitivity and power levels) before it is tested on an aircraft, and repeat the diagnostic after taking aircraft data. If a SUT fails part of the second I-level test, it may explain why that SUT failed aircraft tests. For example, an RWR missed identifying emitters in a certain quadrant during an operational test. After repeating an I-level test, it was later determined that a hardware failure had occurred and there was not a design deficiency with the RWR.</p>	<p>Use appropriate processes to ensure that the SUT is fully serviceable prior to commencement of testing.</p>
<p>Where are the problems in an EW equipment likely to be?</p>	<p>It is rare that a completely new EW or other technology is introduced to a platform. Consequently, in general terms, another test engineer, somewhere in the world has already ‘walked the path’ that you are about to walk when designing an EW SUT or planning and conducting T&amp;E on that EW SUT on a particular platform.</p> <p>Despite this, international experience has shown that many engineers, of all disciplines, have appeared to think that they were the first to design, install, integrate, rig-test, aircraft ground/flight test an equipment of a particular genre, e.g., a radar, a flare/chaff dispensing system, a RWR. SUT designs and test plans have been generated from scratch and few, if any lessons have been learned. In this way many problems and inefficiencies have been re-encountered project after project, within and across Nations.</p> <p>It is beneficial and relatively easy to investigate what problems have been encountered on prior projects introducing or upgrading EW systems on platforms. These problems comprise problems with the SUT itself and T&amp;E problems. For example, understanding where problems are most likely exist on a new towed RF decoy by investigating where problems occurred on prior TRDs, and with the T&amp;E of those TRDs enables:</p> <ul style="list-style-type: none"> <li>• Problem prevention (by SUT/platform design or modification); and</li> <li>• Tailoring, focusing and optimising of T&amp;E philosophy and methodology, procedure and facilities.</li> </ul>	<p>Focus the T&amp;E plan by:</p> <ul style="list-style-type: none"> <li>• Investigating what problems were experienced by others when testing an EW equipment of the type and/or genre you are about to test.</li> <li>• Wherever possible, talk face-to-face with the designers and testers of the prior systems.</li> <li>• If accessible, use prior problem reports on a given EW equipment type to indicate where problems might be.</li> <li>• At the start of a new project, a run-through of all previous problem reports (closed or otherwise) for EW equipment of a similar genre is highly likely to save considerable time and effort in the overall T&amp;E programme.</li> </ul>

TOPIC AREA	PROBLEM, ROOT CAUSE AND COMMENT	LEARNING POINT
<p>Verification via 'read across'</p>	<p>Function and performance verification of a project's deliverables was managed via Specification Verification Matrices, which used the generic verification evidence classes: Inspection, Analysis, Test and Demonstration. This project benefited greatly from realising the opportunity of read across of relevant verification evidence from prior projects, reducing both overall project cost and risk. Some read across was defined/assumed at project outset and more was identified and realised via the risk and opportunity management process.</p> <p>Two issues were encountered that, with hindsight, could have been prevented:</p> <ul style="list-style-type: none"> <li>• Some verification evidence from a prior project was found to have been incomplete and/or incorrect. This project's Factory Acceptance Test process and procedure trapped these few issues.</li> <li>• Adequacy of prior project testing for read across: On one major deliverable it was assumed that the recent prior project had adequately checked out their almost identical deliverable. This proved not to be the case and significantly more testing and problem investigation was required than anticipated, adding considerable risk and duration to this project.</li> </ul>	<ul style="list-style-type: none"> <li>• Minimise project cost and schedule via identification of maximum read across of verification evidence at project outset.</li> <li>• Ensure all read across evidence is appropriately reviewed prior to use, especially items in the 'Test' and 'Analyses' verification categories.</li> <li>• Continually watch out for further read across opportunities, as it is generally easy to realise the cost / time / risk benefits.</li> </ul>
<p>Don't forget multi-path!</p>	<p>During the development phase of a RWR it was thoroughly tested using an open-loop radar environment simulator in a HITL laboratory. The RWR utilised a four-port amplitude comparison system, and the antenna pattern values measured from actual antennas tested at an antenna measurement facility were programmed into the simulator as a function of angle and frequency.</p> <p>Dynamic test scenarios were developed to exercise the system to its specification limits. The test scenarios were put into a digital model that predicted the display for the entire 6 minute scenario.</p> <p>The system was designed to only look for six different kinds of threats. Threat frequency ranges and scan and PRI values were varied over the radar limits. When the display presented something different than the digital model, the contractor was allowed to change the system algorithms until the system was optimised. This took 3 weeks of extensive laboratory test time. The system software was then "frozen" and parametric data were recorded on the capability of the RWR.</p>	<ul style="list-style-type: none"> <li>• Create ground and inter-platform multi-path representative of the planned flight trajectory during SIL/HITL testing by coupling a sample of the signal with the anticipated delay and reflection/diffraction loss. Adding random amplitude and phase modulations increases the fidelity of the multi-path simulation.</li> <li>• Be mindful that, especially for aircraft ground tests, RF energy reflections around the aircraft itself can substantially change test results when compared to anechoic chamber and SIL/HITL trials.</li> </ul>

TOPIC AREA	PROBLEM, ROOT CAUSE AND COMMENT	LEARNING POINT
<p>Don't forget multi-path! (cont'd)</p>	<p>When the system left the laboratory everyone felt the system would perform outstanding during flight test. However, during the first flight when only one threat was radiating, the RWR displayed two and sometimes three symbols at greatly varying angles and ranges! After analysis it was determined that the radar signals were not only going directly into the antenna to be processed but the antennas were receiving the signal reflected off various parts of the aircraft body. The antennas were receiving the same signal from multiple paths! Since the signals were received at slightly different times and amplitudes, the system processed them as separate signals. A great deal of time and money was spent fixing the algorithms to correlate the signals to a single emitter.</p>	<ul style="list-style-type: none"> <li>• The aircraft's stores configuration, including fuel tanks, weapons, jammer pods, etc., significantly alters the number of reflective surfaces involved. Reflection/diffraction in some cases is further complicated by the non-metallic materials some stores are made from.</li> <li>• Computation Electromagnetic Modelling can help predict test results and investigate any problems encountered. CEM can also assist in clearing EW SUT performance against different stores configurations – aircraft test programme durations and budgets usually prohibit EW SUT testing for every stores and aircraft configuration.</li> </ul>
<p>M&amp;S credibility and fitness for purpose</p>	<p>Problems encountered are discussed in Chapter 7, Section 7.8.7.</p>	<p>See Section 7.8.7.</p>
<p>The high value of video recording during aircraft and rig trials</p>	<p>The lack of suitable video recording of EW system and other displays during rig and aircraft ground/flight trials has hampered many trials over the years and made investigation of some of the trickiest problems encountered difficult and time-consuming.</p> <p>Video recording is a well-established diagnostic tool. Where it has been available and been used, it has helped test engineers quickly home in on the root cause of problems and has aided the identification of solution options.</p>	<p>Always consider the use of video recording of key aircraft displays during EW ground and flight trials.</p>

TOPIC AREA	PROBLEM, ROOT CAUSE AND COMMENT	LEARNING POINT
Simulation vs. Stimulation of RF EW SUTs	<p>The simulation/stimulation issue is important to EW, radio and radar systems. The [Platform A] EW SIL experience has shown that most of the RF interface problems that could have been found on the rig using the techniques and test equipment available in fact were found. The bulk of this work was done by low power irradiation of receiver antennas, with a lesser amount of direct, cable-connected transmitter to receiver injection of RF signals. Although some investigation was conducted into direct signal injection at Intermediate Frequencies it was decided that the End-to-End concept should apply – i.e., test the system out as it would be in the aircraft. This investigation has shown that the end-to-end concept is robust for EW systems, with some confidence that many of the RF interface problems would have got through to aircraft had it not been for this approach.</p> <p>There has been a marked reluctance to consider the use of SILs in this area, probably stemming from an incomplete understanding of the power of the rigs as investigative and diagnostic tools for RF problems. For example, the [Platform C] radar-RWR interoperability problem entailed extensive aircraft ground/flight trials for some three years. Although it is accepted that airframe effects could only have been examined on aircraft, it is believed that most of the optimisation of RF ‘windows’ in the RWR could have been carried out using a real radar on the [Platform C] SIL. Thus it is concluded that much time and effort could have been saved in this area.</p>	<p>Use real RF systems on SILs and in anechoic chambers to:</p> <ul style="list-style-type: none"> <li>• Minimise RF interface problems getting to aircraft trials.</li> <li>• Cost-effectively investigate and diagnose RF interface problems.</li> </ul>
Bypassing a platform’s SIL causes problems	<p>As a result of deliberately bypassing tests on a platform’s SIL, problems that could have been discovered on that SIL have subsequently been discovered during EW on-aircraft trials, resulting in a higher cost-to-find and cost-to-fix.</p> <p>In three cases this occurred on the EW systems of [Platforms A and B]: ECM, blanker (RF suppression management unit) and CMDS. The reasons are varied why this problematic short-cut was taken in each case. Some aspects include:</p> <ul style="list-style-type: none"> <li>• SUT cleared for aircraft on the basis of tests with the manufacturer’s test set only.</li> <li>• Prior testing, done years before on a much earlier variant of same platform type, was done by “trial and error”. In retrospect the trials manager concerned described the earlier results as “totally wrong”.</li> <li>• Failure to recognise that SILs have a powerful role to play in RF system testing.</li> </ul>	<p>New or upgraded EW equipments, or those previously fitted to other platforms/variants, should not be introduced to an aircraft type without going through normal system integration tests in the SIL for that type.</p>

TOPIC AREA	PROBLEM, ROOT CAUSE AND COMMENT	LEARNING POINT
<p>Set time limits on troubleshooting</p>	<p>When a problem is encountered during part of a test, set a prudent amount of time to investigate, then continue the original test procedure because if the initial problem cannot be readily understood, subsequent testing and results may provide a clearer understanding or solution of the original problem.</p> <p>As an example, weeks were spent trying to uncover a problem which was caused by an avionics system contractor tying one side of a multiplex bus to a pin labelled ‘no connection’ at the systems, and the airframer grounding the wire going to the ‘no connection’ pin at the airframe end. When the cable was attached to both connectors, the bus was being shorted to ground. All testing was stopped until the problem was found. It would have been better to have spent a day or so, then continue with the original tests, and try to solve the problems in parallel.</p>	<p>To maximise test timescale success probability, especially on aircraft ground trials:</p> <ul style="list-style-type: none"> <li>• Set a limited time for investigation of a problem after encountering it, prior to returning to execute the next test in the planned sequence. A rule of thumb is up to 4 hours.</li> <li>• Conduct further investigation of problems discovered during a test sequence once the entire planned sequence has been completed.</li> </ul>
<p>Understand timing relationships, measurements, and uncertainty</p>	<p>Data analysts must understand what is being measured as well as the precision and accuracy of the measurement. Response time is a common measure of performance in EW RF receiver testing and makes a good example. The response time calculation requires the analyst to know the initial time, i.e., when the radar began to transmit and the time when the event of interest occurred, e.g., the RWR displayed the related symbol.</p> <p>The OAR post-mission test data will include the “ON” times for the subject radar. Analysts must understand exactly what this means. Radars are instrumented in a number of ways. Three common methods and their associated shortcomings are:</p> <ul style="list-style-type: none"> <li>• <b>Switch Position</b> – the instrumentation records the time when the switch is engaged. Instrumenting the switch position tells the analyst when the operator commanded the transmitter to turn on, it does not represent the time that the transmitter actually began radiating. This is a potential error source, since there will be a time difference between the time that the switch was engaged and the time that the transmitter began radiating. This time difference will vary by system and can even vary within a system, for example, a transmitter that is warmed up may come up to full power more quickly than a cold one.</li> </ul>	<p>It is critical that data analysts understand what is being measured, how the MOPs are specifically defined, how accurately the data will allow the MOPs to be calculated, and how these relate to the specified system requirements.</p>



TOPIC AREA	PROBLEM, ROOT CAUSE AND COMMENT	LEARNING POINT
<p>Understand timing relationships, measurements, and uncertainty (cont'd)</p>	<ul style="list-style-type: none"> <li>• <b>Data Bus Message</b> – modern radars and simulators employ software controlled elements and can record when the message commanding the transmitter to engage was sent on the data bus. In this case the initial time will be after the operator commanded the transmitter to turn on. There will be a lag until the command is sent on the data bus. As is the case of instrumenting the switch position, the instrumentation system only records the time that the transmitter was commanded to radiate.</li> <li>• <b>Radio Frequency Transmitted Signal Power Level</b> – a RF detector measures the signal output power level at the transmit antenna. When the signal level exceeds a predetermined threshold the instrumentation records the time of the event. This method can at times actually induce an unusual anomaly: a negative response time, i.e., the SUT receiver detects the RF signal before the instrumentation system records that the radar is transmitting. This can occur because the transmitted power ramps up in amplitude and takes additional time to exceed the reporting threshold. This is most likely to occur when SUT receiver is fast and very sensitive and the radar has a relatively long ramp up time.</li> </ul> <p>Each of these methods can introduce errors and measurement uncertainty.</p>	
<p>Record SUT details and test configuration</p>	<p>Record serial equipment being tested along with the time and date of test. It is amazing how quickly measurement data becomes worthless when a question arises later and the exact test configuration cannot be ascertained or recreated.</p> <p>Although simple, obvious and begging the question “Why is this even in a lessons learned list?”, international experience has shown this to be an intermittently recurrent and fully preventable problem for over 30 years.</p>	<ul style="list-style-type: none"> <li>• All test engineers need to be very disciplined in this regard and treat their test configuration like that for an academic research trial.</li> <li>• All necessary data must be recorded to enable a third party, at some later date, to exactly replicate the test and its results.</li> </ul>

**LEARNING FROM EXPERIENCE**



TOPIC AREA	PROBLEM, ROOT CAUSE AND COMMENT	LEARNING POINT
<p>Monitor the power line during tests</p>	<p>Fluctuations on the power line due to other laboratory equipment being turned on or off may affect the performance of the system being tested. If the surges are outside the permitted limits of MIL-STD-704 or the particular SUT specification, full SUT performance is probably not required and it shouldn't be classified as a test failure. The same is true when ground tests are performed on an aircraft using an auxiliary power unit versus running the aircraft engines. If the power isn't automatically monitored using external equipment, the wrong conclusions about the system's performance may result. Also, ensure that monitoring equipment works.</p> <p>A disturbance analyser was flown in a military aircraft to try to determine why the on-board jammer and RWR were occasionally resetting. After 20 minutes, extensive transients were recorded on phase C of the aircraft power. Since some of the transients seemed too high, the disturbance analyser was tested on the ground. After letting it run for 20 minutes with nothing connected to the input, it started dispensing a tape documenting all kinds of erroneous "transients" on phase C. The disturbance analyser had an overheating problem and we were back to square one on identifying the aircraft problem.</p>	<ul style="list-style-type: none"> <li>• Monitor power lines in the laboratory and during aircraft trials, as voltage interrupts and transients, and spurious and harmonic signals have been the root cause of a number of problems with EW and other avionic equipments.</li> <li>• Be ever mindful that test equipment can be as problematic as the SUT under test. Never discount T&amp;E equipment, especially if containing software, as a SUT problem contributor until you are doubly sure this is true.</li> </ul>
<p>Effects of component response time</p>	<p>A number of problems have been experienced whose root cause was the apparently innocuous change of an internal component's response time. Three examples are provided:</p> <ul style="list-style-type: none"> <li>• A component manufacturer made an assembly change that resulted in an Integrated Circuit (IC) having a faster response time. The static discharge that occurs during airborne refuelling was now sensed by the IC and caused system susceptibility. Therefore, units with the same part number worked differently due to a subtle change in a replacement component.</li> <li>• A comparison path in the receiver of a jammer would occasionally have inconsistent results. The problem was traced to a manufacturing change made by a supplier on an IC that resulted in a faster response time. Therefore, signals from one path were arriving at the comparison circuit too soon to be compared with signals from another path.</li> <li>• An aircraft's new blanker box worked less well than its predecessor. The newer components operated significantly quicker than the older components. The original blanker box specification only stipulated the maximum delay through the circuitry; there was no minimum delay requirement because the "state of the art" at the time of the original design would not allow a problem to occur.</li> </ul>	<p>Always suspect a changed component if timing problems appear on an upgraded SUT and platform installation that previously worked correctly with the earlier version of SUT.</p>

TOPIC AREA	PROBLEM, ROOT CAUSE AND COMMENT	LEARNING POINT
<p>Determination of test point limits</p>	<p>As part of acceptance testing a HPM signal was applied to a system and no damage occurred. When a low power signal was input into the system, normal system operation was observed. However, during middle-level power testing the system suffered damage. The reason was that a Sub-Miniature A (SMA) elbow connector between the system’s antenna and receiver caused the HPM signal to arc. This arcing dissipated the high amplitude energy before it reached the receiver. A middle power level did not arc across the SMA elbow connector, but the power was high enough to burn out electronic components in the receiver.</p> <p>In another instance, the ability of the automatic recovery circuitry of a system to respond to the loss of power for short intervals was tested for losses of aircraft power for a duration of one microsecond and 1 and 10 ms. The system continued to operate properly through the short microsecond dropout of power. Its operation ceased during the 10 ms dropout of power but it automatically recovered when power was reapplied. The system never recovered after a 1 ms dropout of power. The reason was that the system logic was programmed to handle one thing at a time and it was still sequencing through its powering down routine when it received a signal to power up; the logic was not in place to accept this command so the system just hung up. During the 10 ms power drop out test, the system had already completed its power down cycle when the command was received to power up, so it properly followed the command.</p>	<ul style="list-style-type: none"> <li>• Test points should be selected carefully and, where possible, should be chosen to probe the correct operation of a particular element of function or performance.</li> <li>• Avoid selecting ‘maximum and minimum only’, as experience shows this often hides problems that emerge later.</li> </ul>
<p>Radomes – characterisation and post-repair testing</p>	<p>Radomes are used on aircraft nose radars, jammers, RWR/ESM antennas and other RF transmitting/receiving antennnas. Various problems affect their use and effectiveness, most of which impact all types of radomes, and some – such as described below – are particular to nose radar radomes.</p> <p>A nose radar radome serves several purposes. First, it provides an aerodynamically correct shape to the aircraft nose. Second, it shields the internal radar and other avionics from the effects of weather such as rain, sand, etc. It must perform these tasks and remain electrically transparent to radar energy, whilst transmitting and while receiving. The measure of this ‘transparency’ is known as transmission efficiency. The radome must be designed for the particular radar frequency by matching the cross-section structure, thickness, dielectric constant, and materials. Final testing is performed in an anechoic chamber with and without the radome. If a radome is poorly designed or is</p>	<ul style="list-style-type: none"> <li>• Radomes should be fully characterised after damage repair.</li> <li>• When newer radars are fitted into older aircraft, the radomes need to be checked to ensure proper transmission of the new RF energy and the new radiation pattern.</li> </ul>

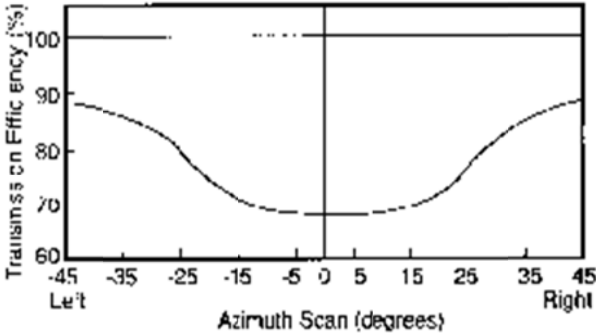
TOPIC AREA	PROBLEM, ROOT CAUSE AND COMMENT	LEARNING POINT
<p>Radomes – characterisation and post-repair testing (cont’d)</p>	<p>damaged, and then is repaired without using proper procedures or testing, the transmission efficiency may be impaired. Figure 9-1 shows the transmission of a radome which had been improperly repaired in the nose area. The “curve” should normally be flat.</p>  <p style="text-align: center;"><b>Figure 9-1: Transmission Efficiency.</b></p> <p>As can be seen, the area directly ahead has a worse transmission efficiency. This can have a major operational impact because an aircraft could be flown into a bad storm, thinking that better weather (weaker return) was in the direction straight ahead. It is postulated that this is what caused at least one aircraft accident several years ago.</p> <p>In addition to not ‘seeing’ weather or targets in selected directions, an improperly designed or repaired radome can create false targets as shown in Figure 9-2. In this particular case, ground return may depict a false ‘storm’ ahead which is at a distance that the aircraft is above ground level.</p>	

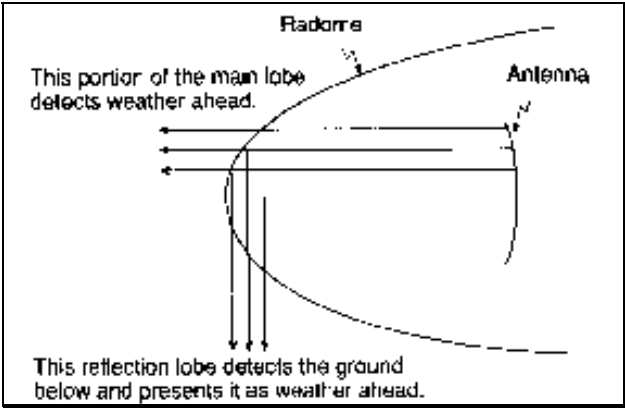
TOPIC AREA	PROBLEM, ROOT CAUSE AND COMMENT	LEARNING POINT
<p>Radomes – characterisation and post-repair testing (cont'd)</p>	<div data-bbox="636 363 1258 772" data-label="Diagram">  </div> <p data-bbox="736 804 1151 831"><b>Figure 9-2: Radome Ground Return.</b></p> <p data-bbox="349 890 1503 954">Note: Figures and background material contributed by Ben MacKenzie, Director, Technology and Engineering, Norton Performance Plastics Corp., Ravenna, Ohio.</p>	
<p>Look at data cross-over regions</p>	<p data-bbox="349 999 1518 1129">During testing, data are frequently taken with several test setups (or layouts) in order to accommodate different measurement scales or instruments covering a different frequency range (or some other variable parameter). It is wise to ensure that data points overlap the ranges of data measurements and that the results in this cross-over region are similar, if not identical.</p> <p data-bbox="349 1145 1518 1347">In cases where different bandwidths are used in the amplitude measurement of pulsed signals, there may be a loss in amplitude since one bandwidth may be narrower, but the difference should be explainable. If there is an unexplained difference in the cross-over region, the spectrum analyser may be saturated by a strong out-of-band signal. If an external 10 dB attenuator is inserted, all data should drop by 10 dB. If not, an RF filter needs to be added to reject the interfering out-of-band signal to get valid measurements.</p>	<p data-bbox="1563 999 2096 1235">Sub-banding of tests, for a variety of reasons, is commonly required to fully cover a particular SUT performance measure. In this case ensure that data is measured to enable verification that data elements in adjacent sub-bands are identical (within measurement error) or fully and satisfactorily explainable.</p>

TOPIC AREA	PROBLEM, ROOT CAUSE AND COMMENT	LEARNING POINT
<p>Don't make assumptions when reporting problems</p>	<p>The system/avionic problem report is the primary method of getting SUT problems fixed. To aid speedy resolution without the need for subsequent investigations, it is important that the test engineer provide as comprehensive and complete a record of the problem, with supporting evidence, as is possible. The report should also be accurate – two examples follow where an incorrectly made assumption hindered rather than helped resolution of the problem:</p> <ul style="list-style-type: none"> <li>• When a RFCM system was initially deployed on an aircraft, it was reported to have transmitted on the carrier deck while in the receive mode. What actually occurred was the transmit light illuminated when the RFCM system was in the receive mode. The witness assumed that since the transmit light was on, the RFCCM system was transmitting. The RFCM system was found to have circuitry for the transmit light that would inadvertently illuminate in either the presence of certain high power RF or certain types of vibration.</li> <li>• In another case, test personnel reported a jammer continued to transmit long after the input signal was withdrawn. What actually occurred was the system would go into a ring-around condition after the signal was withdrawn, and instead of transmitting a high level signal, only low level noise was transmitted. The transmit light illuminated the same but the output power was significantly different. Finding the solution to the problem was delayed due to assuming the transmission was the same because the light didn't change intensity.</li> </ul>	<ul style="list-style-type: none"> <li>• Ensure system/avionic problem reports are accurate, precise, comprehensive and complete. In general, the better the problem report, the quicker the solution.</li> <li>• Provision of photos, figures and other evidence that might help the equipment/software supplier to pinpoint the problem's root cause is strongly recommended.</li> <li>• Don't make assumptions – double check the facts.</li> </ul>
<p>On-aircraft RF coupling (interference) may not be symmetrical</p>	<p>Symmetry of RF coupling, based on a simple view of transmit and receive antennas' placement on an aircraft, is often and reasonably used to justify clearance of a full performance envelope based on extrapolation of a sub-set of physical measurements on that aircraft. For example if RWR antennas are identically mounted at the top extremities of both wings, then coupling from an in-band RF transmitting antenna on the top centre of the fuselage to any of the RWR antennas will be very similar, if not identical.</p> <p>There are cases, unfortunately, where this RF coupling is asymmetric to a greater or lesser degree. For example RF coupling, which may cause interference, from the radar in the nose of the aircraft to symmetrically located EW (or other) antennas on each wing, may not be identical. If the radome for the radar is hinged on one side, the radome material will be thicker on that side and will cause more</p>	<ul style="list-style-type: none"> <li>• Symmetry of on-aircraft RF coupling paths should not be assumed, especially when attempting to justify a reduced T&amp;E programme based on that symmetry.</li> <li>• Antenna pattern modelling should be used to predict the level of symmetry likely to occur on a given platform, which should then be validated by a limited set of measurements.</li> </ul>



TOPIC AREA	PROBLEM, ROOT CAUSE AND COMMENT	LEARNING POINT
On-aircraft RF coupling (interference) may not be symmetrical (cont'd)	attenuation to the backlobe of the radar signal that could couple to other aircraft antennas. If measurements are only performed on that side, no interference or reduced interference could be measured whereas the “mirror image” antenna on the other wing could be receiving more signal and therefore more interference.	
EW man-machine interface	<p>Sub-optimal MMI is a common theme running through many of the problems previously seen during EW T&amp;E. In some cases there has been scathing criticism by aircrew and engineer alike concerning EW display presentation, usefulness and confusion caused when trying to use it ‘in anger’.</p> <p>The execution of MMI assessments early in the design life-cycle, as is more often the case nowadays, helps prevent this type of problem reaching the aircraft, where it is more costly and time-consuming to fix.</p>	Engage EW T&E engineers and aircrew in MMI assessments during the design phase, to minimise problems at the rig and aircraft test phase.
How to know if the problem is the avionics system or the platform	<p>When a SUT passes Intermediate-level (I-level) tests, then fails in an aircraft, and fails a repeat I-level test, suspect aircraft wiring if this sequence occurred in the same aircraft. For example, on one aircraft carrier, seven jammers were tried in an aircraft and none of them passed self-test. All failed subsequent I-level tests. Finally, aircraft wiring was checked and a short was found which was damaging the jammer interface circuitry.</p> <p>When a system passes I-level tests, and fails in an aircraft, then re-passes I-level tests, suspect aircraft wiring, physical or environmental considerations:</p> <ul style="list-style-type: none"> <li>• In one case, a keying connector wasn’t connected and the extra sensitivity that was supposed to be activated in this installation wasn’t obtained. Consequently the jammer failed flight tests against a certain radar.</li> <li>• In another case, the system power supply coolant was low; so when the jammer was flown, the sloshing, shifting coolant uncovered high voltage electronic components that arced thereby causing a failure. In the I-level test facility, the jammer was always tested in a level position and no failure occurred. As a result, test preparation instructions were changed to include testing with one end slightly elevated if a sloshing fluid noise is heard during handling.</li> </ul>	<ul style="list-style-type: none"> <li>• If a serviceable EW SUT is fitted to an aircraft for the first time and it fails, immediately suspect and investigate the aircraft wiring.</li> <li>• Unless unavoidable, <b>do not</b> fit a replacement SUT until the faulty original unit has been investigated and the aircraft and its wiring cleared of involvement in causing the fault.</li> <li>• If a serviceable SUT is off-aircraft re-confirmed as still being serviceable after failing on the aircraft, initially suspect broken wires or incorrect, faulty or mis-connected connectors.</li> </ul>

<b>TOPIC AREA</b>	<b>PROBLEM, ROOT CAUSE AND COMMENT</b>	<b>LEARNING POINT</b>
<p>Try to arrange measurements so measurement errors are obvious</p>	<p>The test engineer can help him/herself by designing tests that include an element of ‘self-checking’. Two examples are given here:</p> <ul style="list-style-type: none"> <li>• When multiple frequency measurements were made of a jammer’s frequency spectrum, three measurements were necessary, i.e., in-band, out-of-band at higher frequencies, and out-of-band at lower frequencies. To preclude saturation of the spectrum analyser when lower power measurements were made at the lower frequencies, it was necessary to use a Low Pass Filter (LPF) to attenuate the strong in-band signal. To preclude measurement data being used when the filter was inadvertently not inserted, the frequency measurement range was extended high enough to include part of the roll-off portion where the LPF was starting to filter. Therefore, all valid measurements showed a decreasing slope in the jammer’s thermal noise at the upper limit of the measurement range.</li> <li>• When antenna-to-antenna isolation tests were performed on jammer antennas on an aircraft, the engineer always performed the test twice. The first test had the energy sent directly into the spectrum analyser. During the second test an external 10 dB attenuator was attached to the analyser. Therefore, if the analyser’s noise floor was being measured in the first set of data (without an attenuator), there wouldn’t be a 10 dB difference with the second set (with the attenuator), i.e., data were invalid and the isolation was greater than measured.</li> </ul>	<p>Where possible, design tests that enable the test engineer to quickly identify if measurement errors are present.</p>
<p>SUT instrumentation and data recording</p>	<p>Even if you have done a very good job under the T&amp;E period with a lot of defined test cards, there will always be situations during flight test operations that the SUT does not behave in a correct way and which was not defined in test cards and perhaps situations that are difficult to recreate. To make it possible to analyse that type of problem it is necessary to have a recording system running all the time.</p>	<p>It is very important to have a very “powerful” internal recording system dedicated for EW purposes in every military aircraft, especially those going in harm’s way.</p>

TOPIC AREA	PROBLEM, ROOT CAUSE AND COMMENT	LEARNING POINT
<p>Airframers need to know what the avionics contractor is thinking</p>	<p>The following examples, although really design and ICD issues, are typical of the more subtle installation problems that can get through to aircraft to be found by the astute test engineer:</p> <ul style="list-style-type: none"> <li>• In one case, the jammer manufacturer assumed that the system’s cooling exhaust fans would not be engaged in a ram air-cooled aircraft because a fan disable switch would be depressed when the cooling plenum was attached to the front of the jammer. The airframe manufacturer didn’t know that and designed the cooling plenum with a cut-out to leave the switch alone. The jammer contractor didn’t realise it until one technical representative reported hearing the fans running while the aircraft was on the ground.</li> <li>• In another case, an older jammer relied on the external coupling of the jammer output to the receiver to completely fill the internal loop delay line with RF energy. The jammer installation only specified the minimum external ring-around attenuation and delay but not the maximum values; therefore, some airframers thought that more attenuation/delay was better and none of the transmitted signal filled up the delay line. As a result, the transmitted signals had gaps between each recirculated segment used to build up the transmitted pulse. It should be noted that in this case, even if the optimum attenuation and delay had been obtained, the combining of out-of-phase pulses/pulse segments caused spreading. Nevertheless, the airframer needs the complete information from the system designer when the characteristics of the aircraft installation affect the system design.</li> </ul>	<ul style="list-style-type: none"> <li>• Before testing on SIL/HITL rigs and on aircraft, engineers should become familiar with the SUT specification and relevant ICDs.</li> <li>• Attention should be paid to the operation of on-aircraft, free-space RF feedback loops as used on many RWR/ESM/ECM systems. These should be replicated or simulation on SIL/HITL rigs.</li> <li>• These rigs should include the same number and type of interlocks and switches as are installed on the aircraft. Test procedures should correctly cover their operation.</li> <li>• Particular attention should be paid to the function and operation of ‘Weight-on-Wheels’ (‘Aircraft-on-Ground’) switches, problems with which has been at the root of many past EW SUT and T&amp;E problems.</li> </ul>
<p>Multiple reporting of EW/Avionic problems</p>	<p>An investigation of DAS T&amp;E rig and aircraft ground/flight trials during a many-year development programme on each of two platform types showed that – with the benefit of hindsight – many more system/avionic problem reports had been raised than was necessary. This resulted in the two programmes being longer and more costly than they could have been.</p> <p>This experience is known anecdotally to be generic across the EW T&amp;E community, although process and procedure enhancements in recent years have improved the situation. The reason for duplicated problem reports fell into three categories, those:</p>	<p>To minimise the risk and number of repeat or duplicate problem reports on a programme:</p> <ul style="list-style-type: none"> <li>• Always adopt an Integrated Test and Evaluation Approach.</li> <li>• Where the same or similar variant of EW equipment is fitted on one or more platforms/variants and is to be fitted to another, always screen open and closed</li> </ul>

**LEARNING FROM EXPERIENCE**



TOPIC AREA	PROBLEM, ROOT CAUSE AND COMMENT	LEARNING POINT
<p>Multiple reporting of EW/Avionic problems (cont'd)</p>	<ul style="list-style-type: none"> <li>• Initially raised on SIL/HITL facilities that were re-investigated and re-raised on aircraft ground and/or flight trials. Sometimes the exact same problem is raised at the rig, aircraft ground test and flight test, with the latter two duplicate reports adding nothing to the original one.</li> <li>• Raised on EW equipment on one platform type then re-raised on the same or very similar equipment fitted on another platform type at a later date.</li> <li>• Which are different facets of the same problem.</li> <li>• The single root cause identified is inadequate visibility to ALL involved departments/agencies of the existence and latest status of problem reports.</li> </ul>	<p>problem reports that were raised on the earlier platform/variant.</p>
<p>Use and limitation of video recording during aircraft RF EW trials</p>	<p>Much EW T&amp;E work in the last two decades has been in the area of relatively high power on-board transmitters interfering with sensitive on-board receivers. Measurement of interference has often been subjective, i.e., by aircrew/engineer comment on displays and/or post-trial analysis of video recordings of EW and other RF equipment displays.</p> <p>Whilst video recording is a powerful development tool and has been used on SILs for many years with great success, it has had a number of shortcomings when considered in the on-aircraft EW context. These are:</p> <ul style="list-style-type: none"> <li>• Subjective and qualitative, rather than quantitative measurement of results of jamming and/or RF interference.</li> <li>• Often poor quality video, caused by the use of cockpit mounted TV camera(s) rather than direct recording of display surface video signals.</li> <li>• Substantial time and effort overhead in post-trial analysis, including the necessity to use experienced EW engineering effort.</li> </ul>	<p>Use direct video recording of display surfaces for T&amp;E investigations of jamming and other interference on on-board EW and other radar frequency receivers.</p>

TOPIC AREA	PROBLEM, ROOT CAUSE AND COMMENT	LEARNING POINT
<p>Conformance to Specification vs. 'Fit for Purpose'</p>	<p>The primary emphasis of Industry T&amp;E engineers in earlier times was to confirm that the platform and EW SUTs met the functional and performance requirements defined in their contract specifications – the basis of being paid by their defence ministry and armed forces customers. This led to some problems encountered on rig and aircraft trials being declared as 'Meets the specification, this is not a problem.'</p> <p>There is now a wider recognition that <i>Fit For Purpose</i> does not mean, as was historically the case, <i>Meets the specification</i>. The combination of specifications, ICDs, and an associated '<i>Capability and Limitations</i>' document provides a clear view of what is and, as important, what is not being provided under a contract. This enables proactive and early resolution of any items that might not be acceptable to the customer. Customer and military end-user agreement to this latter document provides a consistent, all-stakeholder definition of <i>Fit For Purpose</i>.</p> <p>In addition there is an implicit understanding that the SUT needs to be free of serious 'bugs' at the point of delivery to service and during its operational life. This adds a dimension to the above – to approximately quote an American systems engineer "Proving conformance to specification does not prove the absence of faults". It has been observed over many years that a substantial element of the overall T&amp;E effort on EW and other avionics systems has been spent on finding and fixing software/hardware bugs rather than on merely demonstrating conformance to specification.</p>	<ul style="list-style-type: none"> <li>• Produce at contract outset a Capability and Limitations document for a given EW SUT or DAS, agreed by all stakeholders. Update as appropriate during the contract.</li> <li>• Use this document in conjunction with SUT specifications and ICDs to guide and optimise the scope, duration and cost of the EW T&amp;E Plan.</li> </ul>
<p>Tape recordings can help pinpoint audio interference</p>	<p>When audio interference was heard on an aircraft internal communication set, a tape recorder with high frequency metallic tape capability was used to record the sounds with the interfering system on and with it off. The recording was then played back into a spectrum analyser with the 'max hold' function selected. By comparing the two spectrum analyser presentations, the frequency of the interference was calculated, which then enabled engineers to determine the specific circuits causing the interference.</p>	<p>As with video recordings, see other lessons learned, high quality audio recordings can be very useful when investigating on-aircraft interference.</p>

**LEARNING FROM EXPERIENCE**



TOPIC AREA	PROBLEM, ROOT CAUSE AND COMMENT	LEARNING POINT
<p>Unexplained EW SUT effects during testing</p>	<p>During rig and aircraft ground and flight trials sensitive EW receivers have, on a number of occasions, suffered from display freezes, software re-starts and stoppages, and/or inaccurate/ambiguous fault indications. Many have, upon investigation been either ‘unexplained’, ‘unrepeatable’, ‘not understood’ or considered (usually by the equipment supplier) as ‘unrepresentative test’.</p> <p>Some have been traced to sensitivity to supply voltage transients when other, high current aircraft equipments are turned on or between off, standby and on modes, i.e., an EMC/EMI problem.</p> <p>Others are thought to fall into a category of ‘catching’ the EW computing hardware/software at some time-critical point in its processing cycle. This type of problem is generic to computer systems and can be extremely difficult to repeat, fully diagnose and solve. Despite this, it is thought from the circumstantial evidence gathered over the years that many may, in the final analysis, have been caused by noise/voltage transients on signal or earth lines either within the EW system or at the interface with the aircraft supplies.</p>	<p>To aid replication, investigation and resolution of any such problems:</p> <ul style="list-style-type: none"> <li>• Use video recording during tests.</li> <li>• Monitor power lines into and out of the EW receiver system’s own power supply unit.</li> </ul>
<p>‘Subjective’ investigation of RF coupling problems</p>	<p>Much EW T&amp;E work in the last two decades has been in the area of relatively high power on-board transmitters interfering with sensitive on-board receivers. Investigations of such problems, especially when involving ECM systems, have been lengthy, some have been inconclusive, and a number have been very cost-ineffective – resulting in little or no improvement. This resulted from one of more of these reasons:</p> <ul style="list-style-type: none"> <li>• No modelling of ECM to RF antenna/receiver coupling, which would immediately identify the type of interference (in-band transmitters affecting in-band receivers, or out-of-band interference).</li> <li>• No in-depth assessment of the problem and its causes, or review of equipment design to establish if potential solutions were capable of offering required level of improvement.</li> <li>• A minimum of antenna coupling measurements, necessary to confirm those predictions.</li> <li>• Subjective assessment of interference seen (“better than before” – even if it is still considered unacceptable).</li> <li>• Limited quantitative measurements of victim SUT-received interference power/frequency.</li> </ul>	<p>To minimise technical risk and RF interoperability test timescales:</p> <ul style="list-style-type: none"> <li>• Prior to aircraft tests use M&amp;S (Computational EM) to establish whether there is likely to be any inter-system interference.</li> <li>• Confirm correct RF interoperability via whole aircraft tests in an anechoic chamber ISTF.</li> <li>• Conduct a minimum of on-aircraft investigations when/if unexpected interference is encountered. Then go back to the M&amp;S models to investigate the problem and potential solutions prior to returning to the aircraft for further testing.</li> </ul>



TOPIC AREA	PROBLEM, ROOT CAUSE AND COMMENT	LEARNING POINT
‘Subjective’ investigation of RF coupling problems (cont’d)	<ul style="list-style-type: none"> <li>• Somewhat un-scientific approach to possible solutions: stick a bit of RAM here, then there; swap ECM from one wing to the other; RAM paint application.</li> </ul>	
The utility of ‘Confirmatory’ testing	<p>Prior investigations have shown that in most cases each successive stage of tests, (Supplier CoC, Platform Supplier Acceptance Test, SIL Pre-Integration/Integration, aircraft ground test and flight test), is broadly a sub-set of the earlier one, but with much repeat test work being conducted.</p> <p>If this situation is inspected logically from a cost effectiveness point of view, no test should be repeated unless it either demonstrates an aspect of conformance to specification or is specifically requested by the Customer in the contract. This request, if it is present at all, is likely to be more of a Public Relations exercise – giving him ‘confidence’ – rather than a technical necessity.</p>	<ul style="list-style-type: none"> <li>• Screen existing test plans and procedures to remove redundant and costly ‘confirmatory’ tests. Avoid their use in future plans and procedures.</li> <li>• In this way the SUT supplier’s tests should be the most technically exhaustive followed, in decreasing order of duration and complexity by avionics rig, aircraft ground and aircraft flight testing.</li> </ul>
Problems with RF connectors	<p>Two primary problems have been experienced repeatedly over the years and across a wide variety of platforms:</p> <ul style="list-style-type: none"> <li>• Aircraft RF cables, when connected to EW equipments, have not always been torqued up correctly. In some cases they have only been connected ‘finger tight’. For correct EW SUT performance it is essential that all RF connectors are correctly torqued up. Failure to do so can lead to degraded performance – sometimes not bad enough for the SUT’s BIT system to detect but bad enough to adversely affect overall threat direction finding, detection and identification performance. Sometimes the BIT will indicate a faulty LRU when, in fact, there is no problem with the LRU. This can lead to lost test time, nugatory investigation and the availability impact of LRU ‘No Fault Found’.</li> </ul>	<ul style="list-style-type: none"> <li>• When connecting aircraft RF cables to EW black boxes always correctly torque up RF connectors to assure performance and prevent problems.</li> <li>• Double check RF cable connections to EW RF receiver LRUs/LRIs on SIL/HITL avionics rigs and aircraft.</li> <li>• Check for the RF cable swapping problem on RWR/ESM installations by conducting a simple, walk-around quadrant check using a RF signal source.</li> </ul>

**LEARNING FROM EXPERIENCE**



TOPIC AREA	PROBLEM, ROOT CAUSE AND COMMENT	LEARNING POINT
Problems with RF connectors (cont'd)	<ul style="list-style-type: none"> <li>Aircraft RF cables to RWR/ESM antennas and/or receivers being accidentally swapped over due to lack of connector keying or difficulty seeing connector idents on the LRU when installed in the aircraft. An often result of this is that emitters in two quadrants appear in the opposite quadrants. This kind of mis-connection can be trapped by a walk-round test of the aircraft using a hand-held RF emitter simulator.</li> </ul>	
Use of SIL and HITL facilities for EMC testing and investigations	<p>Generally, the aircraft is the only real place where full system EMC can be confirmed. The risk of EMI and other EMC-related problems is minimised by robust design practice and EMC qualification of individual LRUs/LRIs.</p> <p>Historically, avionics rigs with SIL and HITL facilities were not designed or suitable for EMC testing. Nowadays many modern avionics rigs use aircraft grade cable with representative lengths, they utilise aircraft screening/earthing/bonding schemes, and have 'cockpits' with aircraft equipment laid out as they are in the aircraft. Whilst predominantly designed this way from an integrated avionics system testing standpoint, this has made them more electromagnetically representative of the aircraft.</p> <p>Some limited, system-level EMC risk reduction work can be conducted on the SUT on such rigs. Pulsed and CW RF Bulk Current Injection tests have been shown to have good correlation with on-aircraft test results. This can aid early identification of problems, prior to aircraft use, and provides an off-aircraft investigative tool for EW and other avionics EMC/EMI problems.</p>	Consider the use of avionics rigs in SIL/HITL facilities for EMC/EMI testing and investigations.
'Parallel' SIL and aircraft flight testing	<p>A few examples of 'parallel' testing have been seen. This is where a software and/or hardware update or new package is delivered to the SIL and aircraft at the same time. A bare minimum switch-on clearance test is conducted then the aircraft ground/flight trials are allowed to proceed in parallel with full SIL integration/assessment activities.</p> <p>Whilst this approach can theoretically be used in an attempt to save time or recover development programmes experience shows this to be a high risk, poor payback option in practice. All that happens is the problems, some of which are major, which should have been found on the rig, are instead first found in flight with a much higher cost and timescale penalty. In one case a two-aircraft flight trial and associated post-trial investigations were totally wasted.</p>	<ul style="list-style-type: none"> <li>Ensure optimal use of SIL (sub-systems and avionics integration) facilities by following the Integrated Test and Evaluation and Acceptance process.</li> <li>Do not take the risk of jumping straight to flight test without passing EW and other avionics through the SIL process.</li> </ul>

TOPIC AREA	PROBLEM, ROOT CAUSE AND COMMENT	LEARNING POINT
<p>‘Un-repeatable’ test problems</p>	<p>There are occasions where a problem has been seen once during EW rig and aircraft trials with the SUT and/or with test equipment being used in the T&amp;E process, but which cannot at that time be repeated. In the past some have either:</p> <ul style="list-style-type: none"> <li>• Chosen to ignore the occurrence (“It’s not repeatable, so cannot be a problem.”);</li> <li>• Attempted to repeat the problem a small number of times as part of the ongoing trial, after which it is declared not to be a problem; or</li> <li>• Decided not to record/progress any definitive action to reproduce it beyond that briefly conducted during the ongoing trial.</li> </ul> <p>Some such problems have only re-surfaced again once the platform has been in operational use for some time. Some of these have had unacceptably adverse operational impact and a significant amount of time and effort has then had to be expended ‘hunting gremlins’ – usually with some success. Some problems have been repeatable and on more than one occasion the problem has been repeated, but only when an out of the ordinary (but allowable) sequence of keyboard or other ‘button’ pushes has been effected.</p> <p>A phrase often encountered over the years when sharing experiences on such problems with other users of the SUT and/or platform and/or test facility/equipment is “We’ve seen that!” – accompanied with the information that they also haven’t formally recorded the problem either, for the same reasons as above.</p>	<ul style="list-style-type: none"> <li>• Record all problems seen during trials using the system/avionic problem reporting process, then move any un-repeatable problem to a ‘Watch List’ if not re-encountered within a reasonable period of time.</li> <li>• Ensure all relevant stakeholders in the platform and SUT (as appropriate) are aware that there is a risk of such problems recurring at some point during the SUT’s operational life.</li> <li>• Optimise problem early fix potential by sharing such information with the manufacturer of the test equipment, SUT or platform.</li> </ul>
<p>Investigate test response when SUT is not connected</p>	<p>A test result may not be what you expect when a system is not connected. For example, while evaluating the effectiveness of I-level tests of a jammer on a piece of Ground Support Equipment (GSE), the tests were run on the GSE without the jammer connected. Surprisingly, five of the 100+ tests passed! It turned out that the noise floor of the measurement instruments in the GSE was being measured and its power level was within the limits of these tests for the jammer. Therefore, these particular tests could never fail and they needed to be changed.</p>	<ul style="list-style-type: none"> <li>• Be mindful that test equipment is not perfect. This includes GSE, COTS (e.g., spectrum analysers) and other Special-To-Type Equipment.</li> <li>• Some can, under certain conditions, provide indications or give measurements that incorrectly suggest a ‘Pass’.</li> <li>• Familiarity with the test equipment is the best defence against this type of problem.</li> </ul>

**LEARNING FROM EXPERIENCE**



TOPIC AREA	PROBLEM, ROOT CAUSE AND COMMENT	LEARNING POINT
Commonality of test tools and training	<ul style="list-style-type: none"> <li>• Cases have been encountered where different sites/divisions of the same company have obtained different results from testing due to the use of different measurement equipment and/or procedures and/or training.</li> <li>• This is especially relevant when considering RF EW tests conducted at different sites, divisions, agencies and companies, where different RF threat simulators and other emitter generation equipment has been used.</li> </ul>	<ul style="list-style-type: none"> <li>• At the T&amp;E planning stage, ensure appropriate levels of test tools and training commonality across the test engineering stakeholders irrespective of their agency.</li> <li>• If adequate commonality cannot be determined at that point, factor in how the differences will be taken into account during the T&amp;E process.</li> </ul>
Microwave testing problems	<p>A number of typical problems have been encountered during microwave testing at various levels, from EW component, box and system testing in the laboratory, via SIL/HITL to aircraft testing in ISTF and in support of flight test and trials. Learning points for a few are presented at right.</p>	<ul style="list-style-type: none"> <li>• Always use isolators in any microwave test set-up, to minimise risk of damage to unprotected components.</li> <li>• Always take a transmission and reception measurement before starting to test: this will provide the tester with the current equipment set-up losses which can be taken into account.</li> <li>• Ensure that component, sub-system and system tolerance coning is correctly carried out prior to commencement of practical T&amp;E.</li> <li>• Always check that the antenna under test is on boresight before commencing initial radiation pattern measurements. The non-use of a simple VSWR meter to obtain this is common practice and lends itself to poor results being gained.</li> </ul>

<b>TOPIC AREA</b>	<b>PROBLEM, ROOT CAUSE AND COMMENT</b>	<b>LEARNING POINT</b>
Microwave testing problems (cont'd)		<ul style="list-style-type: none"> <li>• Check that antenna radiation patterns do not show signs of bifurcation on the main lobe: there are times when such a feature is so small that it is easily overlooked. It is at this point that judgement needs to be made as to whether reposition, or continue testing.</li> </ul>
Basic test set-up	<p>The use of basic test set-ups is good practice. Too often have engineers used previous test set-ups only to find at a crucial point that their results are invalid because a small but important item of test equipment was missing.</p>	<ul style="list-style-type: none"> <li>• Have a basic test configuration thought out and always return the equipment to this state following the completion of a phase of testing.</li> <li>• Have basic test set-ups detailed in block diagram format and available to non-RF engineers. This enables seconded personnel to set-up equipment by themselves. It was then checked by engineers familiar with RF before test commencement.</li> </ul>
Test equipment calibration	<p>Test equipment being found out of calibration at the start or during a test phase remains a problem that is intermittently encountered. Another facet is when an item goes out of calibration just after the originally planned test completion date – but is now a problem as the aircraft trial has been extended.</p>	<ul style="list-style-type: none"> <li>• Ensure all required test equipment for a given test phase will be inside calibration for the duration of the trial.</li> <li>• Ensure sufficient schedule reserve on the calibration past the planned completion of the test phase. If this is not possible, arrange loan or hire of a replacement equipment to minimise risk to the test programme.</li> </ul>

TOPIC AREA	PROBLEM, ROOT CAUSE AND COMMENT	LEARNING POINT
<p>Adequacy of ‘problem’ and ‘equipment failure’ time</p>	<p>Invariably test and/or SUT failures are encountered during T&amp;E programmes. Problems are also usually encountered during the testing, which require investigation – some at the time and more at a later point during or at the end of the tests. Often the planned programme schedule does not allow sufficient time to cater adequately for these realities of T&amp;E.</p>	<ul style="list-style-type: none"> <li>• Plan testing thoroughly: build in problem investigation time and equipment failure time.</li> <li>• Plan which test elements have priority 1, 2 and 3, should such problems and failures occur during a given test phase. Agree this with the customer before beginning. Have a mid-test meeting to discuss progress and problems. Hold an end-of-test wash-up meeting.</li> </ul>
<p>Airframe harmonic effects</p>	<p>The energy radiated by higher order harmonics of a high power transmitter on an aircraft interfered with the operation of other onboard systems. To solve the problem two changes were made. A low-pass filter was incorporated into the system output design and the system’s antenna was designed to minimise the generation of second, third, etc., harmonics.</p> <p>Anechoic chamber tests indicated the design objectives were met, but when the system was installed on the airframe, interference was still seen on other onboard systems. The problem was determined to be that the dissimilar metal surfaces of the airframe acted as non-linear devices and induced harmonics onto the reflected signal. In an initial attempt to change the characteristics of the reflections, the wing surface was pounded with a rubber mallet! The harmonics disappeared but shortly thereafter they reappeared.</p>	<ul style="list-style-type: none"> <li>• Transmit and receive antenna function and placement is best optimised using Computational Electromagnetic Modelling (CEM).</li> <li>• This includes maximising isolation between in-band and harmonically related antenna pairs, and maximising coverage (polar patterns) in required directions.</li> <li>• CEM is beneficial when introducing or re-locating antennas.</li> <li>• CEM’s benefit is multiplied when dealing with antennas on airframes made of dissimilar materials, e.g., Carbon Fibre Composites, titanium and aluminium.</li> </ul>



## **9.4 REFERENCES**

- [1] Berkowitz, P.H., “EW Testing Lessons Learned”, Track: SOS/DST 16 June 1998. Report: A302553. Internet: <http://dodreports.com/pdf/ada355203.pdf>. Last accessed: 12 October 2011.
  
- [2] Stadler, K.M., “Test and Evaluation Lessons Learned from the Field”, Defense Acquisition Journal, September 2007, pp. 396-408. Internet: [http://www.dau.mil/pubscats/PubsCats/ARJ45\\_Stadler.pdf](http://www.dau.mil/pubscats/PubsCats/ARJ45_Stadler.pdf). Last accessed 12 October 2011.

## **9.5 FURTHER READING**

Conference Proceedings for the annual U.S.A.F. T&E Days, organised by the American Institute of Aeronautics and Astronautics. Internet: <http://www.aiaa.org/content.cfm?pageid=320> Last accessed 25 November 2011.



## **Annex A – ELECTRONIC WARFARE T&E FACILITY DESCRIPTIONS**

### **A.1 INTRODUCTION**

This annex provides descriptions of known EW and related T&E facilities in NATO Nations. Whilst it does not fully describe every resource that a project may wish to utilise, it represents a valuable resource for understanding the range of facilities available to meet the goals of a structured test process.

### **A.2 FACILITIES LISTING**

This annex was compiled by the authors with the help of the national representatives on SCI FT3, and it is the most current available at the point of issue. All information has been provided by the respective facilities. It is non-exhaustive; for new and/or upgraded facilities information, check with your national representative. To assure the latest information on any facility or resource, engage with the Point of Contact given at the end of each listing.

<b>NATION</b>	<b>FACILITY/RESOURCE NAME</b>	<b>ORGANISATION/LOCATION</b>	<b>PRIMARY DESIGNATION</b>
GBR	Electromagnetic Modelling Group	BAE Systems, Lancashire	M&S
ITA	Antenna Design and Testing Group	Alenia Aeronautica S.p.A., Turin	M&S
DEU	Cassidian Computational Electromagnetics	Cassidian, Manching	M&S
USA	Integration Facility for Avionic Systems Testing	USAF, Edwards AFB, California	SIL
USA	Portable Seeker/Sensor/Signature Evaluation Facility	USAF, Eglin AFB, Florida	SIL
USA	ECSEL	USN, Point Mugu, California	HITL
USA	Benfield Anechoic Facility (BAF)	USAF, Edwards AFB, California	ISTF
GBR	EW Test Facility (EWTF)	BAE Systems, Lancashire	ISTF
USA	Air Combat T&E Facility (ACETEF)	USN, Patuxent River, Maryland	ISTF
GBR	Electromagnetic Test Capability	BAE Systems, Lancashire	ISTF
ITA	Anechoic Shielded Chamber	Alenia Aeronautica S.p.A., Turin	ISTF
ITA	Electromagnetic Open Area Test Sites	Alenia Aeronautica S.p.A., Turin	ISTF
USA	J-PRIMES	USAF, Eglin AFB, Florida	ISTF
DEU	Cassidian EME Test Facility	Cassidian, Manching	ISTF
USA	Electronic Combat Range (ECR)	USN, China Lake South Range, California	OAR
SWE	Vidsel EW Test Range	Swedish Defence Materiel Administration, Vidsel	OAR
USA	Center for Countermeasures (CCM)	US DoD, White Sands Missile Range, New Mexico	OAR
GBR	Joint EW Core Staff	NATO, RNAS Yeovilton	OAR
USA	T&E Support for Aircraft Survivability	USAF, Eglin AFB, Florida	OAR
GBR	Trials/Test Support Group	ESL Defence Systems, Hampshire	OAR

## ANNEX A – ELECTRONIC WARFARE T&E FACILITY DESCRIPTIONS

---

In addition to the above, some Nations also maintain a catalogue of T&E capabilities, some of which are applicable to EW. Examples include:

NATION	CATALOGUE TITLE/REFERENCE	CONTACT
GBR	UK Test and Evaluation Catalogue D/Wpns/TEST/03/02/07/CatalogueV6 dated July 2011	<a href="mailto:DESWpnsTEST-TECC2@mod.uk">DESWpnsTEST-TECC2@mod.uk</a>

### A.3 MODELLING AND SIMULATION RESOURCES

#### A.3.1 Electromagnetic Modelling Group

##### TEST RESOURCE CATEGORY

Primary: M&S / Other: (Not Applicable).

##### LOCATION

BAE Systems, Military Air Solutions, Warton, Lancashire, UK.

##### NARRATIVE DESCRIPTION

The Group has access to a suite of Computational Electromagnetic Modelling (CEM) codes covering all the major frequency and time domain modelling techniques (see Capability Summary). These are used on a 512 core parallel processing supercomputer capable of 1.5 TFLOPS with 1.5 TBytes of core memory, which is dedicated to electromagnetic modelling.

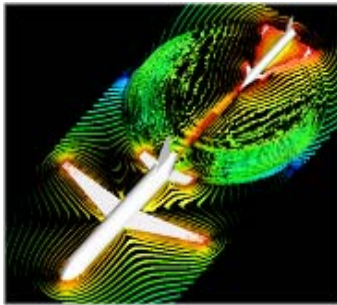
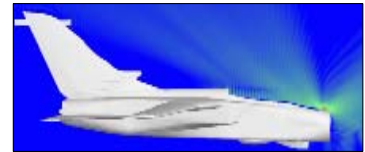

The Group can import design data (structure, cabling and pipework, including material properties), directly from Computer-Aided Design (CAD) systems and, with a minimum of intervention, automatically create suitably gridded geometries. Thus 1 billion cell models are regularly created and analysed. For microwave frequencies the ray tracing codes are available.

This computational facility is utilised by the Group's experienced, specialist engineers to provide solutions to a wide range of electromagnetic problems

including installed antenna performance, in terms of polar diagrams, antenna coupling and RF systems performance. The latter uses the installed antenna modelling output in modelling tools which enable assessment of communications link performance in different scenarios and platform, RF interoperability analysis.

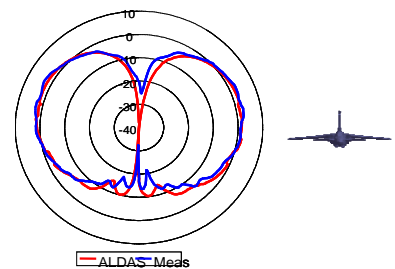

The capability is also used to simulate the interaction of lightning, Electro-Static Discharge (ESD), Electromagnetic Pulse (EMP) and High Intensity Radiated Fields (HIRF) with systems internal and external to any platform, including cable currents and equipment electromagnetic environment.

It is used throughout the design and support life-cycle to establish concepts, carry out design optimisation and risk reduction through to design verification and supporting qualification of 'first of type' and upgrades during in-service support.

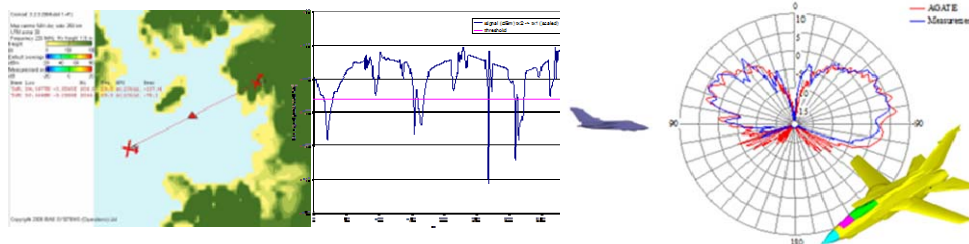

(Images © BAE Systems 2011, All Rights Reserved)

**CAPABILITY SUMMARY****Electromagnetic Software Tools**

Most of the applications software has been developed and maintained within BAE Systems to meet general requirements across a broad range of products and design solutions. A key aspect of these facilities is the link to CAD generated geometry accommodating all major CAD systems.

All major electromagnetic modelling codes/methods are represented including:

- Transmission Line Method (TLM)
- Finite Difference Time Domain (FDTD)
- Boundary Element (BE)
- General and Uniform Theory of Diffraction (GTD/UTD)
- Fast Multi-Pole Method (FMM)
- Hybrid finite element / finite difference
- Antenna communications link modelling software
- Antenna coverage modelling software

**Applications**

The engineers are experienced in applying our modelling tools to address a wide range of electromagnetic threats, interactions and issues seen on vehicles, systems and other structures including:

- Installed antenna interoperability (coupling)
- RF systems performance, including the propagation path
- Un-installed and installed antenna coverage (polar diagrams)
- Antenna/system range
- Lightning strike (direct and indirect effects)
- Electromagnetic Pulse (EMP)
- Electrostatic Discharge (ESD)
- Electromagnetic Compatibility (EMC) and High Intensity Radiated Field (HIRF) threats

Our engineers have wide experience using electromagnetic modelling on many practical products (now certified and in service) in all parts of the product life-cycle, including concept, design, certification and through-life support.

**Computational Electromagnetics High Performance Computing**

Large parallel super-computers are required for the grand-challenge scale of processing required for whole vehicle, high fidelity simulations. The facilities are dedicated to electromagnetic computer analyses as these tend to involve long run-times which are incompatible with multi-user shared resource environments. The most powerful facility currently available is:

**HP/Quadrics Cluster:**

- 64 compute nodes each containing dual AMD Athlon 64 -bit quad core processors giving a total of 512 cores
- 1.5 TByte core memory
- Quadrics QSNNet II high performance interconnect

**POINT OF CONTACT**

Mr. Paul Baker  
Group Leader, EM Computation  
BAE Systems, Military Air Solutions (W423A)  
Warton Aerodrome, Warton, Preston  
Lancashire, PR4 1AX, UK  
Tel: +44 (0)1772 853571  
Fax: +44 (0)1772 855262  
Email: [paul.baker@baesystems.com](mailto:paul.baker@baesystems.com)



### A.3.2 Antenna Design and Testing Group

#### TEST RESOURCE CATEGORY

Primary: M&S / Other: N/A.

#### LOCATION

Alenia, E3 -Avionic Systems and Laboratories, Turin, ITALY.

#### NARRATIVE DESCRIPTION

The Group is involved in the analysis of the antenna performance installed on Alenia platform, using the commercial state-of-art computational tools based on the principal frequency and time domain techniques to solve Maxwell's Equations. Electromagnetic problems are solved with a dedicated network of nine 64-bit workstations, with 640 GBytes of core memory that can manage multi-processor computations.

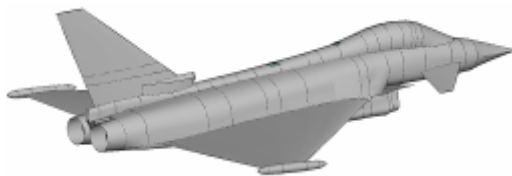
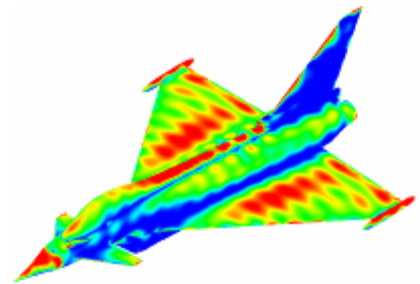

The tools are able to import directly the Computer-Aided Design (CAD) files, including cable routing and material properties, that the engineer experts will correct in an accurate and reliable model, from an Electromagnetic (EM) point of view. The main activity of the group deals with aircraft EM design: antenna siting aiming to ensure properly

positioning of antennas on platform fuselage and to minimize/control unwanted EM interference between on-board transmitters and receivers, taking into account all aircraft mechanical constraints. Antenna to Antenna Coupling values, Antenna Radiation Patterns and Antenna Near Field Iso-Surface values can be numerically calculated, visualized and exported for further post-processing analysis. During and after design phase,

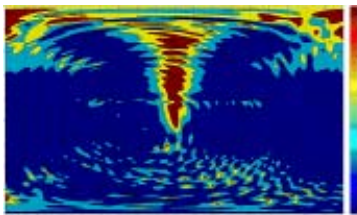
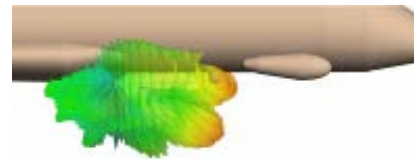

confidence and accuracy of computational results can be assessed by performing only a small set of representative measurements, using computational predictions as a starting point for informed and efficient measurement preparation and planning. The HW computational capability allows the performance of parallel processing for overcoming all of the most demanding electromagnetic problems, such as evaluation of Radar Cross-Section at air vehicle level.

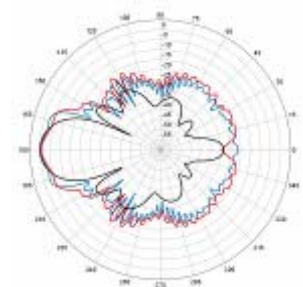
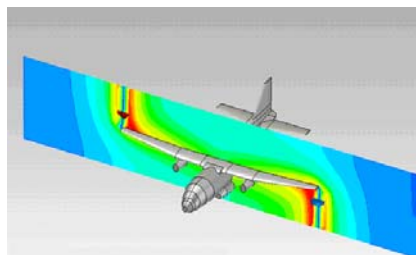
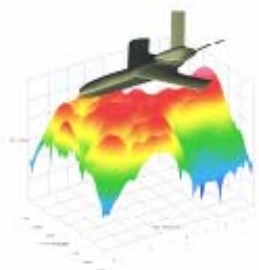

**CAPABILITY SUMMARY****Electromagnetic Software Tools:**

Almost all of the state-of-art EM numerical tools are available for Antenna Design and Testing group. Electromagnetic techniques/codes available are reported in the following:

- Method of Moment (MoM)
- Multi-Level Fast Multiple Method (MLFMM)
- Finite Element Method (FEM)
- Boundary Element Method (BEM)
- Finite Differential Time Domain (FDTD)
- Approximate EM formulations such as Physical Optical (PO), Geometrical Optical (GO), Uniform Theory of Diffraction (UTD), Physical Theory of Diffraction (PTD), Large Element PO (LEPO)
- Hybrid formulations such as MoM/PO, MoM/GO, MoM/UTD, MoM/PTD, MLFMM/LEPO, FEM/MLFMM, MoM/MLFMM
- Shooting Bouncing Ray (SBR) and incremental length diffraction coefficient algorithms for radar cross-section analysis

**Applications**

Antenna engineering expert use the HW and SW facilities to solve a wide variety of electromagnetic problems

- Antenna design
- Antenna placement (coverage)
- Antenna-to-antenna coupling
- RF interoperability analysis
- Lightning strike (direct and indirect effects)
- Bidirectional cable field co-simulation
- Electromagnetic Compatibility (EMC) and High Intensity Radiated Field (HIRF)

The available computational tools and the know-how engineers acquired in several years allow to adequately solve complex electromagnetic problems: in the last years the major activity has been the antenna placement. Now, group is able to predict global electromagnetic aircraft environment.

**Computational Electromagnetic Computing**

Dedicated network of 64-bit workstations are used to solve electromagnetic problems, guaranteeing good accuracy and confidence between calculated results and measured value. The most powerful facility currently available is:

**HP/Dell Network:**

- Eight 64-bit workstations, dual-quad core Intell, with a total of 64 processor and 512 GByte of core memory
- One 64-bit workstation, dual-quad core Intell, with 128 GByte of core memory

**POINT OF CONTACT**

Mr. Ilario Bertino  
Engineering, Avionic Systems and Laboratories – ASYS  
Electromagnetic Environmental Effects Manager  
Alenia Aeronautica S.p.A.  
Strada Malanhero  
10072 Caselle Torinese (TO) – ITALY  
Tel: +39 011 9960446; Fax: +39 011 9960502  
Mobile: +39 366 6813929  
Email: [ibertino@alenia.it](mailto:ibertino@alenia.it)  
A Finmeccanica Company

### A.3.3 Cassidian Computational ElectroMagnetics

#### TEST RESOURCE CATEGORY

Primary: CEM.

#### LOCATION

CASSIDIAN, Manching, GERMANY.

#### NARRATIVE DESCRIPTION

Cassidian has a custom 3D numerical simulation capability, for the full spectrum of electromagnetic applications, including antenna design and integration, for military, space and civil applications.

In support of this, a highly professional EM numerical tool set and high performance simulation computer hardware are available.

Computational EM Analysis is useful when measurements are not possible or practical with respect to time or costs, or when EMC tests (e.g., RE, CE, RS, CS) have FAILED and no solution was found, or when extremely high requirements exist with respect to Radiated or Conducted Emissions, as well as when EMC confidence is required to show compliance before prototyping.

CEM is also useful when Antenna performance needs be optimised for maximum operating distances, or for assessing whether commercially available antennas are suitable for specific applications, or when the antenna measuring equipment and/or expertise is not locally available.

Cassidian has substantial experience in 3D numerical simulations on advanced fighter A/C and other systems, in the prediction of very complex electromagnetic coupling behaviour.

Programs already supported include the Eurofighter TYPHOON, the Panavia TORNADO, the C-160 TRANSALL, and the P-3C ORION CUP.

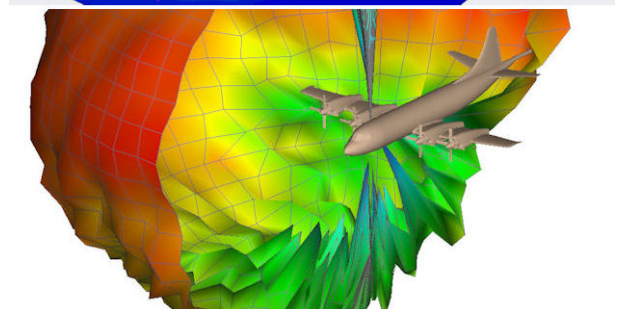
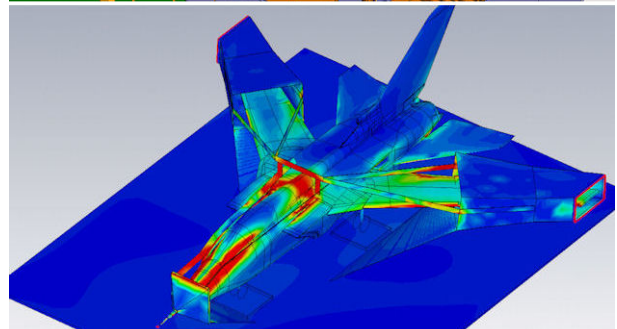
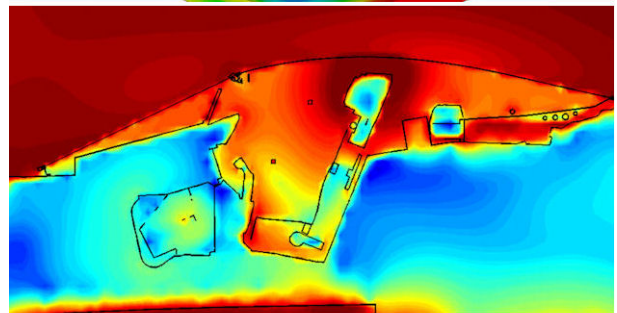
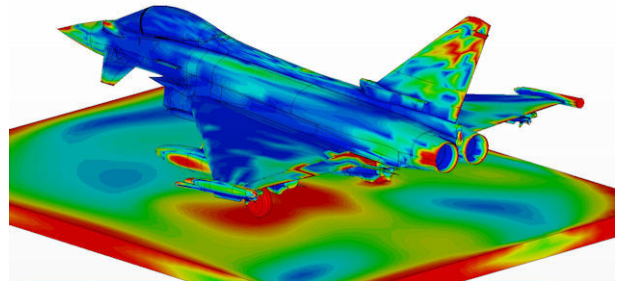

**CAPABILITY SUMMARY****Application Examples**

- Radiated emissions from electronic equipment
- Shielding effectiveness
- Lightning analysis for direct and indirect effects
- Lightning zoning of all kind of vehicles
- Determination of unknown electromagnetic resonances based on current distribution analysis, with all kinds of materials, e.g., metal, carbon, composites, plastics.
- Verification of protection measures against all kinds of EMC related threats, such as conducted susceptibility (CS-XX), radiated susceptibility (RS-XX), LEMP and NEMP
- Antenna design, e.g., thin-film conformal annular slot antennas
- Antenna modelling of the radiation characteristics where measurements are not practical
- Access to non-destructive, 3D X-ray scanning
- Human safety: Definition of safety zones for high-power transmitters
- Disguised antennas: Adaptation of antenna designs to hide them in structural parts
- Performance simulation in specific environments, e.g., behind a radome
- Co-site interference analysis, decoupling and spectrum management
- Link predictions based on 3D wave propagation analysis

**Electromagnetic Software Tools**

- FEKO – Method of moments, MLFMM, FEM, GO, PO, UTD
- CST Microwave Studio – Finite Integration Technique and other EM solvers
- ASERIS BE/FD – Boundary Element Method with GUI, Finite Difference Time Domain with GUI, Mesher
- Wireless Insite – Uniform Theory of Diffraction + empirical models for wave propagation analysis
- Hypermesh – CAD Meshing
- E3-Expert – Interference analysis tool

**High Performance Computational Electromagnetics Computing Facilities**

- 2-Node High-Performance Cluster (4 x Xeon Hexa-Core CPUs, 24 Cores @ 2.7 GHz, 384 GB RAM, ≈ 400 GFLOPS)
- 4-Node High Performance Cluster (8 x Xeon Quad-Core CPUs, 32 Cores @ 3 GHz, 284 GB RAM, ≈ 600 GFLOPS)
- 4-Node Cluster (4 x Xeon Dual-Core CPUs, 16 Cores @ 3 GHz, 64 GB RAM)

**POINT OF CONTACT**

CASSIDIAN  
Rechliner Straße  
85077 Manching  
GERMANY  
Tel: +49 (0) 84 59. 81 – 6 41 34  
Email: [harald.werner@cassidian.com](mailto:harald.werner@cassidian.com)



## **A.4 SYSTEM INTEGRATION LABORATORY**

### **A.4.1 Integration Facility for Avionic Systems Testing**

#### **TEST RESOURCE CATEGORY**

Primary: SIL / Other: M&S, HITL.

#### **LOCATION**

Edwards Air Force Base, California, USA.

#### **NARRATIVE DESCRIPTION**

The System Integration Laboratory (SIL) is a flyable F-16 cockpit and simulation dome with significant Hardware-In-The-Loop (HITL) environment and open-air capability. This spread bench test environment provides Test Pilots and Engineers with a safe and effective environment for system evaluation and training. This unique capability also supports integration of new development items such as targeting pods, tactical data links, weapons, sensors and other items. Available spectral environments include Radio Frequency (RF), Electro-Optic (EO), Infrared (IR), and Electromagnetic Support Measures (ESM). The SIL supports Developmental Test (DT), Operational Test (OT) and other special test activities as determined by its customers.

Manned Flight Simulation (MFS) provides pilots and engineers capabilities to train and assess weapon systems during initial development, or in sustainment and modernization activities. Aircraft representative cockpits and displays are mechanized with aircraft Operational Flight Profile (OFP) software, driven by functional simulations to provide flight dynamics and/or avionics stimulation. High resolution and 360 degree horizontal / 240-degree vertical field of regard out-the-cockpit video provide a realistic environment to exercise weapon system capabilities. MFS provides the USAF and its contractors with a safe and effective environment for familiarization, develop flight profiles and test event timing, develop detailed test card procedures, and develop and debug aircraft systems, mature flight test procedures and timing, and assess weapon system performance. MFS supports Developmental Test (DT), Operational Test (OT) and other special test activities as determined by its customers.

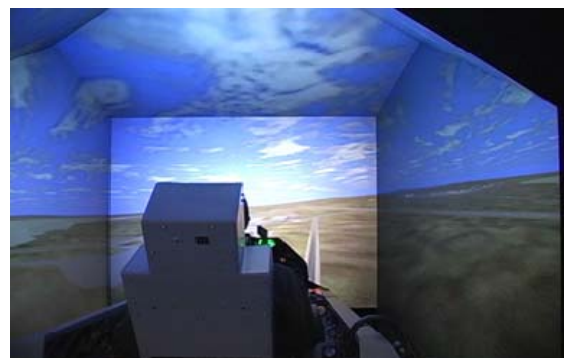

## ANNEX A – ELECTRONIC WARFARE T&E FACILITY DESCRIPTIONS

### CAPABILITY SUMMARY

<p><b>SIL Capabilities</b></p> <ul style="list-style-type: none"> <li>• Human factor interface</li> <li>• Flight safety evaluations (i.e., ground collision avoidance)</li> <li>• Mission development and rehearsal</li> <li>• Full avionics system test <ul style="list-style-type: none"> <li>• Avionics suite integration/testing</li> <li>• Line replaceable unit level testing</li> <li>• Anomaly investigation</li> <li>• Communications, navigation, ID</li> </ul> </li> <li>• Sensor integration</li> <li>• EW blue/red man-in-the-Loop stations</li> <li>• Weapons simulation, integration, and testing</li> <li>• Digital bus and video data retrieval</li> <li>• Crewmember/engineer familiarization/training</li> <li>• Distributed linking (situational awareness)</li> <li>• Tactical data links: Link-16, SADL, IDM</li> </ul>	<p><b>SIL Configurations</b></p> <ul style="list-style-type: none"> <li>• F-16 Cockpits (complete avionics hardware suite supporting Blocks 30, 40, 50, M3 and M4 architectures)</li> <li>• APG-68 Radar operators console</li> <li>• Link-16 landline or open-air</li> </ul> <p><b>Environmental Simulations</b></p> <ul style="list-style-type: none"> <li>• Fog</li> <li>• Time-of-day</li> <li>• Pressure/temperature altitude variations</li> <li>• Flat or spherical earth coordinate system</li> </ul>
<p><b>Mission Threat Environment</b></p> <p>The SIL can be linked with the Digital Integrated Air Defence (DIADs) simulation to provide an enemy air defence threat environment. The DIADs includes air interceptors, radar posts, GCI positions, filter centers and command post simulations with real operator in the loop capability.</p> <p>Other threat capability features include:</p> <ul style="list-style-type: none"> <li>• Graphically displayed air-to-air and air-to-ground targets and threats</li> <li>• Synthetic target sensor models to support Targeting Pod (TGP) and Fire Control Radar (FCR)</li> <li>• Synthetic RF target generation for stimulating actual radar systems</li> <li>• Combat Electromagnetic Environment Simulator (CEESIM) RF threat generation</li> </ul>	
<p><b>MFS Capabilities</b></p> <p><b>Flight Sciences</b></p> <ul style="list-style-type: none"> <li>• Envelope expansion</li> <li>• Flight control failure</li> <li>• Flight dynamics</li> <li>• Human factors with integration studies</li> <li>• Emergency procedures</li> <li>• Sensitivity analysis</li> <li>• Mission rehearsal</li> </ul>	<p><b>Environment Conditions M&amp;S</b></p> <ul style="list-style-type: none"> <li>• Ownship winds</li> <li>• Fog/clouds</li> <li>• Rain/snow</li> <li>• Lighting with communication degradation</li> <li>• Time-of-day with sun/star positions</li> <li>• Sea states</li> <li>• Pressure/temperature altitude variations</li> <li>• Flat or spherical earth coordinate system</li> </ul>

### POINT OF CONTACT

412<sup>th</sup> EW Group  
30 Hogle Avenue  
Edwards AFB, CA 93524-8210, USA  
Tel: 661-275-7615 (DSN 525)



**A.4.2 Portable Seeker/Sensor/Signature Evaluation Facility****TEST RESOURCE CATEGORY**

Primary: SIL / Other: N/A.

**LOCATION**

Eglin Air Force Base, Florida, USA.



**NARRATIVE DESCRIPTION**

The Portable Seeker/Sensor/Signature Evaluation Facility (PSSSEF) provides several different flexible airborne and ground instrumentation platforms that can host an interchangeable mix of instrumentation that allows full characterization of surface and airborne targets. Hi-fidelity target signatures are critical for seeker/sensor development, guided weapons evaluation via simulated engagements, and live fire target validation. Measured target signatures are used to develop and validate digital signature models for hi-fidelity simulated weapons engagements. For example, IR and EO models can be provided in SPIRITS, CHAMP, and Real-Time CHAMP (RTC). The PSSSEF can collect and provide data in a wide variety of test scenarios including: simultaneous multi-spectral measurements of ground, sea, and airborne targets; measurement and characterization of aircraft flares and decoys; measurement of transmission, attenuation and backscatter of aerosols, obscurants and chaff; radar cross-section measurements of sub- or full-scale vehicles; characterization of radar absorbing material performance; background clutter measurements; antenna gain pattern measurement; and the effects of battlefield smoke, dust and chaff on C3I systems. PSSSEF provides signature measurements across the full operational spectrum including infrared, ultraviolet, visible, RF/millimeter wave, acoustic, seismic, and magnetic and can perform a full complement of measurements providing temporal, spatial, spectral, SAR/ISAR, LADAR, and calibration data. Several airborne carriage platforms are available including an F-15 for sub-sonic and supersonic carriage, a UH-1N Helicopter, and a Beech 18 aircraft. Ground facilities include the 300 ft Santa Rosa Island tower for land, sea, and air measurements, the 300 ft Seeker Test and Evaluation Facility (STEF) tower, and various test vans and trailers.



## ANNEX A – ELECTRONIC WARFARE T&E FACILITY DESCRIPTIONS

### CAPABILITY SUMMARY

 <p>300 ft Open-Air Simulation Tower on Santa Rosa Island</p>	 <p>Seeker Test and Evaluation Facility</p>
<p><b>IR/UV/Visible Measurements</b></p> <ul style="list-style-type: none"> <li>• Temporal, spatial, spectral</li> <li>• 1.5 – 3 microns</li> <li>• 3 – 5 microns</li> <li>• 8 – 12 microns</li> <li>• 263 – 281 nm (UV)</li> <li>• Visible</li> </ul>	<p><b>RF and Millimeter Wave (MMW)</b></p> <ul style="list-style-type: none"> <li>• Ground, tower, and airborne-based systems</li> <li>• 10, 35, 95 GHz</li> </ul>
<p><b>Key IR/UV/Visible Instruments</b></p> <ul style="list-style-type: none"> <li>• STIRRS – Staring IR Radiometric System</li> <li>• ABSTIRRS – Airborne Staring IR Radiometric System</li> <li>• CIGARS – Calibrated IR Ground/Airborne Radiometric System</li> <li>• ASIMS Airborne Spectral IR Measurement System</li> <li>• TELOPS – 320 x 256 Ft Imaging Spectrometer (3 – 5 microns)</li> <li>• FLIR Systems SC6000 Imaging Radiometers (640 x 480 long wave, mid wave, short wave, and near IR)</li> </ul>	<p><b>Key RF and MMW Instrumentation</b></p> <ul style="list-style-type: none"> <li>• AMIRS (Advanced MMW Imaging Radar System): 7, 10, 17, 35, and 95 GHz</li> <li>• MROCS-2 – (MMW Obscurant Characterization Sys): 10, 35, and 95 GHz</li> <li>• Lynx: Ku-Band Synthetic Aperture Radar (SAR) on B-18</li> <li>• MERAJS (MMW Emitters, Radars, and Jamming Sys)</li> <li>• MMS (MMW Materials Measurement Sys)</li> <li>• DEWSIM (Directed Energy Weapons Simulator) consisting of various high-power microwave sources</li> </ul>

### POINT OF CONTACT

Mr. Jerry Griffith  
 Technical Director 782d Test Squadron  
 Tel: 850-882-9819, DSN 872-9819  
 Fax: 850-882-9929  
 Email: [jerry.griffith@eglin.af.mil](mailto:jerry.griffith@eglin.af.mil)

## **A.5 HARDWARE-IN-THE-LOOP**

### **A.5.1 ECSEL**

#### **TEST RESOURCE CATEGORY**

Primary: Hardware-In-The-Loop Ground Facility.

#### **LOCATION**

Naval Air Warfare Center Weapons Division, Pt. Mugu, California, USA.

#### **NARRATIVE DESCRIPTION**

Occupying 10,000 square feet of high security Radio Frequency (RF) shielded space, the ECSEL houses threat simulation, instrumentation, and computer resources required to perform developmental test and evaluation of new EW systems and techniques, integration of EW components and sub-systems, and testing of new software revisions for EW systems presently deployed. Commonality between simulations on the ECR range and in the ECSEL make the ECSEL an efficient facility for troubleshooting EW system problems revealed during flight test.



The test approach used in the laboratory is one that incorporates actual EW system hardware interacting with the threat simulator. The threat simulators operate in real time at actual frequencies and receiver power levels. Open-loop RF environment simulators provide high signal densities which model emitter characteristics of threat systems such as airborne, land-based, and shipboard radars, as well as active command guidance signals for missile systems. Closed-loop simulators provide high fidelity replication of complete radar directed weapons systems such that the effectiveness of active jamming responses can be measured. Closed-loop simulations also include missile hardware simulation for semi-active threat systems. A scenario control computer, with associated aircraft cockpit and flight controls, provides the means to coordinate the simulators and incorporate realistic flight dynamics in the test process. This allows the EW system to be “flown” in laboratory scenarios that represent the electromagnetic environment encountered in actual combat or scenarios that will stress the EW system to its limits.

## **ANNEX A – ELECTRONIC WARFARE T&E FACILITY DESCRIPTIONS**

---

### **POINT OF CONTACT**

NAWCWPNS

Brad Coler

Code 454310E

Pt. Mugu, CA 93042, USA

Tel: 805-989-3401

Fax: 805-989-3408



## A.6 INSTALLED SYSTEMS TEST FACILITIES

### A.6.1 Benefield Anechoic Facility (BAF)

#### TEST RESOURCE CATEGORY

Primary: ISTF / Other: MF, SIL, HITL.

#### LOCATION

Edwards Air Force Base, California, USA.



#### NARRATIVE DESCRIPTION

The Benefield Anechoic Facility (BAF) provides the installed system ground Test and Evaluation (T&E) element of the EW T&E process. This facility offers customers cost effective comprehensive ground test capabilities to thoroughly evaluate current and future complex, highly integrated, software-intensive avionics suites and EW systems installed on host aerospace platforms as well as ground-based platforms.

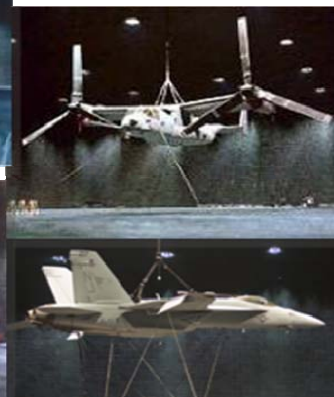
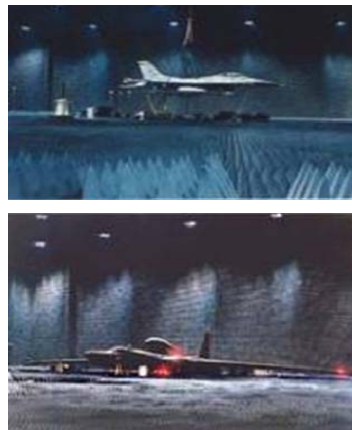

The primary purpose of the BAF is to test integrated avionics systems in a secure, controlled, and repeatable electromagnetically quiet environment using state-of-the-art simulation and stimulators that closely duplicate real combat mission environments. The test team also has collected, modeled, and generated high fidelity threat waveforms that are representative of the Open Air Range (OAR). It is also an ideal installed system test facility to evaluate performance and investigate anomalies associated with ground and airborne EW and avionics systems and tactical missiles and their host platforms.



Capabilities include simulation of airborne and ground-based threat radar, Communication, Navigation, Identification (CNI) simulation; radar target generator, GPS and GPS jamming; electromagnetic interference and compatibility testing and antenna pattern measurement and system of systems testing in a secure, dense environment.

The size of the large chamber also allows for far field RF radiation, thereby making most simulations much more accurate. The BAF is ideal for interoperability testing between multiple aircraft placed in the chamber simultaneously. The BAF supports Network Centric Operations testing with its ability to provide an electromagnetically dense threat environment coordinated with high bandwidth Link 16 test scenarios. The facility includes monitoring and instrumentation, two man-rated hoists, a turntable, interconnecting networks, a test control room, presentation rooms, and office space, and a small anechoic chamber for component tests. These laboratories can work autonomously or collectively to provide varying levels of test and analysis capabilities. All the laboratories are connected via a fiber optic network for communication, instrumentation, and data collection, monitoring and recording.

The Radio Frequency (RF) signal acquisition system provides independent measurement of all intentionally radiated RF emissions seen during testing. The signal acquisition system can provide both a

## ANNEX A – ELECTRONIC WARFARE T&E FACILITY DESCRIPTIONS

near real-time analysis and a record of time sensitive, event driven, emitter activities and responses. These records include high resolution power, precision pulse-width, and accurate pulse interval measurements. The system is versatile enough to capture free space threat emissions or provide input ports to perform direct injections for source calibration or troubleshooting.

### CAPABILITY SUMMARY

<p><b>Benefield Anechoic Facility</b></p> <ul style="list-style-type: none"> <li>• Anechoic chamber and several shielded test laboratories</li> <li>• Offices, conference rooms</li> <li>• Secure facilities (tailored to program requirements)</li> </ul>	<p><b>Chamber Dimensions</b></p> <ul style="list-style-type: none"> <li>• Shield: 264 ft long x 250 ft wide x 70 ft high</li> <li>• Flight line door: 196 ft wide x 66 ft high</li> <li>• Three man doors</li> </ul>
<p><b>Support Services</b></p> <ul style="list-style-type: none"> <li>• 175 ton 80 ft diameter turntable can rotate the system under test +/- 180 degrees at a 0.1 – 0.6 deg/sec.</li> <li>• Two 40-ton hoists</li> <li>• Aircraft electrical power: <ul style="list-style-type: none"> <li>• 400 Hz, 115 VDC, 3Ø (General)</li> <li>• 270 VDC (Supports F-22 and JSF)</li> <li>• Support multiple aircraft simultaneously</li> </ul> </li> <li>• Instrumentation power: 28 VDC, etc.</li> <li>• Cooling air: 6,600 CFM @ 10 PSI @ 30°F</li> <li>• Hydraulic system: 4,000 PSI MIL-H-5606 and 83282</li> <li>• Two Polyalphaolefin (PAO) Systems</li> </ul>	<p><b>Shielding</b></p> <ul style="list-style-type: none"> <li>• Isolation: 100 dB 0.5 – 18 GHz</li> <li>• Quiet zone: 15 – 55’ height x 209’ x 180’ <ul style="list-style-type: none"> <li>• -72 dB @ -0.5 GHz</li> <li>• -84 dB @ 1 GHz</li> <li>• -96 dB @ 2 GHz</li> <li>• -100 dB @ 3 – 18 GHz</li> </ul> </li> <li>• Anechoic frequency range: 0.4 – 18 GHz</li> </ul>
<p><b>RF Transmission and Reception</b></p> <ul style="list-style-type: none"> <li>• Both free space radiation and direct injection capabilities are available</li> <li>• Free space radiation has 20 RF generation carts arranged in the chamber to provide the desired sector and angle of arrival density</li> <li>• Travelling Wave Tube (TWT) and solid-state amplifier configurations available</li> <li>• Programmable, with control over all simulation and hardware functions. Scenario simulations are fully dynamic, providing for static or moving threats</li> <li>• Direct injection capability provides various combinations of signal density and injection ports</li> <li>• RF signal reception configuration: <ul style="list-style-type: none"> <li>• All RF generation carts output monitored continuously</li> <li>• Chamber environment continuously monitored for SUT emissions and spurious signals</li> <li>• ECM response measurement</li> <li>• Threat simulator output verification</li> <li>• Chamber RF environment characterization</li> <li>• Integration of jammer pod response waveforms with a radar target return</li> </ul> </li> </ul>	<p><b>Instrumentation</b></p> <ul style="list-style-type: none"> <li>• Free space: 24-channel CEESIM MkN</li> <li>• Surface and airborne radars &gt; 1000 simultaneous emitters</li> <li>• Dense threat environment (&gt; 2 M pulses/sec)</li> <li>• High Fidelity Intrapulse Modulation (HFIM)</li> <li>• Provides pulse shaping capability every 15 ns</li> <li>• 21 channels with fast tuning synthesizers</li> <li>• 3 channels with slow tuning synthesizers</li> <li>• 2 amplifier configurations TWTA and SSA</li> <li>• Fiber optic connectivity to 20 carts which can be placed anywhere on the chamber floor</li> <li>• Frequency band 100 MHz – 18 GHz</li> <li>• Direct inject: 6 channels (amp and phase) CEESIM MkN</li> <li>• Designed for multiple port and channels configuration</li> <li>• Fast tuning synthesizers or digitally tuned oscillators</li> <li>• Frequency band 100 MHz – 18 GHz</li> <li>• Portable: 5 channels CEESIM MkN</li> <li>• Fast tuning synthesizers or digitally tuned oscillators</li> <li>• Frequency band 100 MHz – 18 GHz</li> <li>• Joint communication simulator system</li> <li>• Scenario based, complex RF signal generation system</li> <li>• Capable of creating a realistic, simulated RF environment comprised of thousands of CNI emitters/data links on thousands of platforms</li> </ul>





**POINTS OF CONTACT**

Mr. Mario Dorado  
Technical Director  
772 TS/CT  
30 Hoglan Avenue, Building 1030  
Edwards AFB, CA 93524, USA  
Tel: 661-277-8352  
Fax: 661-277-7768  
Email: [Mario.Dorado@edwards.af.mil](mailto:Mario.Dorado@edwards.af.mil)

Mr. Steven Louton  
Technical Director  
772 TS/CT  
30 Hoglan Avenue, Building 1030  
Edwards AFB, CA 93524, USA  
Tel: 661-277-7538  
Fax: 661-277-7768  
Email: [Steven.Louton@edwards.af.mil](mailto:Steven.Louton@edwards.af.mil)

**A.6.2 EW Test Facility (EWTF)**

**TEST RESOURCE CATEGORY**

Primary: ISTF / Other: MF, SIL, HITL.

**LOCATION**

BAE SYSTEMS, Military Air Solutions, Warton, Lancashire, UK.

**NARRATIVE DESCRIPTION**

The EWTF complex comprises an aircraft-sized, RF- and laser-shielded anechoic chamber, shielded rooms, and an EW Sub-System Test Laboratory, all TEMPEST grade. It is co-located with the Division’s Electromagnetic Engineering Department, who run the EWTF and other related M&S, MF, HTIL and SIL capabilities. Together, this whole-domain Electromagnetics Capability provides a flexible and reliable whole-life design and T&E service to military and other platforms. With EW T&E resources including state-of-the-art Combat Electromagnetic Environment Simulator (CEESIM) and Signal Measurement System (SMS)<sup>1</sup> for RF threat simulation and ECM response and analysis, other standard laboratory test equipment, and all necessary support infrastructure, the EWTF supports:

Free space chamber ‘*electronic battlefield*’ testing of un-installed EW equipment, sub-systems, systems, and of installed EW systems on combat-sized aircraft and other platforms of similar size, in total electromagnetically secure conditions.

Direct signal injection and measurement testing of EW systems in a SIL/HITL environment.

The figure shows a selection of aircraft tested in the EWTF. The platform is immersed in a virtual battlefield for EW testing. Whilst primarily a ‘drive in, drive out’ EW ISTF, it is also used as an EW MF for installed antenna performance measurements, high intensity radiated field EMI/EMC testing, and full threat lightning testing. These are usually whole aircraft tests in the chamber, and the EWTF is simultaneously an EW MF and an Electromagnetics ISTF. The EWTF houses Computational Electromagnetics super-computers, the department’s primary M&S capability. 1 – 18 GHz RCS measurements are also conducted in the chamber. These are described elsewhere in Annex A.



**Selection of Aircraft Tested in EWTF**  
 (© BAE Systems 2011, all rights reserved)

<sup>1</sup> CEESIM and SMS are Northrop Grumman Amherst Systems products.

**CAPABILITY SUMMARY**

<p><b>EWTF Complex</b></p> <ul style="list-style-type: none"> <li>• Anechoic chamber and sub-system test laboratory</li> <li>• Offices, conference rooms, visiting team room</li> <li>• Secure vault (up to top secret; multi-Nation partitioned)</li> <li>• Peritrack access from EWTF to nearest runway</li> </ul>	<p><b>Anechoic Chamber Dimensions</b></p> <ul style="list-style-type: none"> <li>• Shield: 30 m long x 23.8 m wide x 13.5 m high</li> <li>• RAM-tip to RAM-tip: 29.1 m x 22.9 m x 12.5 m</li> <li>• Main door: 16 m wide x 12.5 m high</li> <li>• Two human-sized access doors, one double door</li> </ul>
<p><b>Shielding</b></p> <ul style="list-style-type: none"> <li>• Shielding &gt; 100 dB from 10 kHz to 40 GHz</li> <li>• TEMPEST grade, fully welded shield</li> <li>• Quiet zone 18.2 m diameter, 9.5 m high</li> <li>• Two quiet zone locations: centre and 4.7 m offset toward main door</li> <li>• Quiet zone performance (up to 40 GHz): <ul style="list-style-type: none"> <li>• Monostatic: -90 dB</li> <li>• Bistatic: -80 dB</li> </ul> </li> <li>• Laser/electro-optic/IR/UV testing: Class 4 laser-tight, double safety door interlocks</li> </ul>	<p><b>Support Services</b></p> <ul style="list-style-type: none"> <li>• 70 tonne static capability</li> <li>• 30 tonne crane and 30 tonne turntable: independent and synchronised operation, 0.1 – 1.0°s<sup>-1</sup> rotation rate</li> <li>• Sub-turntable laboratory and services room</li> <li>• Power: single/3Ø UK, 115/200 V 400 Hz 3Ø aircraft</li> <li>• Hydraulics: Max 280 bar, 180 litres/minute</li> <li>• Compressed air: &gt; 10 bar, 22 m<sup>3</sup>/minute</li> <li>• Static and mobile CCTV and video recording</li> <li>• Multi-zone fire detection and suppression: <ul style="list-style-type: none"> <li>• Smoke/heat, thermal cameras (RAM temperature)</li> <li>• Water deluge: 1 ton/second for 3 minutes</li> </ul> </li> </ul>
<p><b>RF Transmission and Reception</b></p> <ul style="list-style-type: none"> <li>• Six threat site multi-antenna stacks: <ul style="list-style-type: none"> <li>• Four corners, at floor level; one at centre of wall opposite door; one at top of that wall</li> <li>• Steerable stacks, with laser pointer</li> <li>• Multiple transmit/receive antennas per stack</li> </ul> </li> <li>• Threat simulation configurations: <ul style="list-style-type: none"> <li>• Basic: 21 TWTAs (microwave/millimetre wave)</li> <li>• Variety of other amplifiers, up to 1 – 18 GHz 1 kW CW and 9 kW pulsed (4%)</li> </ul> </li> <li>• Basic RF signal reception configuration: <ul style="list-style-type: none"> <li>• ECM response measurement</li> <li>• Threat simulator output verification</li> <li>• Chamber RF environment characterisation</li> </ul> </li> </ul>	<p><b>Instrumentation</b></p> <ul style="list-style-type: none"> <li>• 11 channel CEESIM MkN: <ul style="list-style-type: none"> <li>• Microwave/millimetre wave channels</li> <li>• 2 high speed synthesiser channels, 6 others available to be fitted as needed by test</li> <li>• 256 emitters, 256 platforms, simultaneous at RF</li> <li>• Modes: stand-alone, close-coupled and fully controlled by external control computer</li> </ul> </li> <li>• SMS / Time synchronisation system: <ul style="list-style-type: none"> <li>• Wide-band, digitized IFM receiver</li> <li>• Dual-channel, 80 MHz instantaneous bandwidth</li> <li>• Extensive real-time/post-processing capability</li> <li>• Event-driven signal capture</li> </ul> </li> <li>• EW measurement system: <ul style="list-style-type: none"> <li>• Microwave/millimetre wave, 10 MHz bandwidth</li> <li>• 25 MHz sampling ADC, 90 minute recording</li> </ul> </li> <li>• Other: Microwave laboratory analysers, data</li> </ul>

Further information: Pywell, M. and Midgley-Davies, M. Improved Test Capabilities for Cost-effective Performance Evaluation of Airborne Electronic Warfare Systems, J.RAeS, V.114, No.1158, September 2010.

**POINT OF CONTACT**

Mr. Stuart Richmond  
EWTF Group Leader, Building W423A (EWTF)  
BAE Systems, Military Air Solutions, Warton Aerodrome  
Warton, Lancashire PR4 1AX, UK  
Tel. +44-(0)1772-858436  
Email: [Stuart.Richmond@baesystems.com](mailto:Stuart.Richmond@baesystems.com)

**A.6.3 Air Combat Environment Test and Evaluation Facility (ACETEF)****TEST RESOURCE CATEGORY**

Primary: ISTF.

**Location**

Naval Air Warfare Center Aircraft Division (NAWCAD), Patuxent River, Maryland, USA.

**NARRATIVE DESCRIPTION**

The Integrated Battlespace Simulation and Test (IBST) Department, within NAVAIR, owns and operates the Air Combat Environment Test and Evaluation Facility (ACETEF). This fully integrated ground test facility supports Test and Evaluation (T&E) of highly integrated aircraft, weapon systems, and ground vehicles in a secure, controlled and electromagnetically quiet environment. ACETEF provides cost-efficient ground-testing capabilities for a multitude of programs across the DoD, commercial systems and aircraft.



ACETEF supports installed systems testing in a warfare environment using state-of-the-art stimulation and simulation technology. It also has a combination of laboratories that offer risk-reduction, compliance check and system performance for aircraft, their systems, and the warfighter. These laboratories provide realistic open-loop and/or closed-loop multi-spectral environment stimulation to Electronic Warfare (EW), sensor, communications, navigation and identification systems during both developmental and operational testing.

ACETEF is the T&E center of excellence for Modeling and Simulation (M&S) of the modern Battlespace environment behaviors and interactions. It provides credible, repeatable models of highly complex, interactive and reactive environments as well as scenario development and UAS expertise. The facilities utilize and support multiple warfare environment models and is the developer of two government-owned, license-free, mission-level models that support acquisition decision, warfare analysis, aircraft/aircraft systems, ground testing evaluation, and training.

ACETEF has the flexibility to create custom, real-time data displays and data gathering systems to aid customers in extracting the data they require from ground test events. The team's capabilities range from performing system simulation, providing ground-test support and stand-alone testing on installed aircraft Electronic Warfare (EW), Navigation (NAV), and Communication (COM) systems.

ACETEF operates a number of shielded and anechoic test facilities on the East and West Coast which provide a secure, uncontaminated RF environment to perform testing on installed avionics and handheld equipment. From a Boeing 707 sized aircraft to microchips, the facilities accommodate test vehicles at any size.

**CAPABILITY SUMMARY**

<b>Shielded Hangar</b> <ul style="list-style-type: none"><li>• Has surrounding labs that provide uninterrupted realistic signals to systems under test</li><li>• Provides a controlled, secure and realistic test environment for system stimulation</li><li>• Accommodates multiple platforms</li><li>• Built to accommodate multiple large aircraft</li><li>• Wire mesh covered doors and walls, enabling Electromagnetic Environmental Effects (E3) testing, TEMPEST and COMSEC certification, and electronic warfare suite integration</li><li>• Provides a secure and realistic test environment for system stimulation</li><li>• Has access to three major runways</li></ul>
<b>Aircraft Anechoic Test Facility (AATF)</b> <ul style="list-style-type: none"><li>• 100'L x 60'W x 40'H</li><li>• Designed for tactical size aircraft and helicopters</li><li>• Overall signal attenuation in the chamber is greater than 100 dB over a frequency range of 140 kHz to 40 GHz</li><li>• Has surrounding labs that provide uninterrupted realistic signals to systems under test</li></ul>
<b>Advanced Systems Integration Laboratory (ASIL)</b> <ul style="list-style-type: none"><li>• Anechoic Chamber test Area: 180'L x 180'W x 60'H (32,000 square feet of floor testing area)</li><li>• Can accommodate two tactical aircraft (up to 40 tons) or one E-6 or Boeing 707 sized aircraft.</li><li>• Chamber isolation (15 kHz – 40 GHz) is specified as 100 dB. Maximum reflectivity of the RAM varies from -3 dB at 30 MHz, to -45 dB at 37 GHz.</li><li>• “U-shaped” pit under the chamber floor for stimulation equipment; signal cables are passed through ports in the floor</li><li>• Preparation area between chamber door and weather door keeps temperature on chamber door steady to prevent warping and provides additional area for testing</li><li>• The Operations Control Center (OCC) provides an area where tests can be controlled and viewed and is accessible to networks, simulator displays and SUT cameras</li></ul>
<b>Electromagnetic Interference (EMI) Chambers</b> <ul style="list-style-type: none"><li>• 3 full anechoic chambers<ul style="list-style-type: none"><li>• 20' x 15' x 10'</li><li>• 24' x 20' x 10'</li><li>• 24' x 15' x 10'</li></ul></li><li>• 1 mode stir chamber</li><li>• 20' x 16' x 10'</li></ul>

**POINT OF CONTACT**

NAWCAD Business and Partnership Office (BPO)  
Building 505, Room 117  
22473 Millstone Road  
Patuxent River, MD 20670-5304, USA  
Email: [NAWCAD.NBO@Navy.mil](mailto:NAWCAD.NBO@Navy.mil)  
Tel: 301-342-1133  
[WWW.NAVAIR.NAVY.MIL/IBST](http://WWW.NAVAIR.NAVY.MIL/IBST)



**A.6.4 Electromagnetic Test Capability**

**TEST RESOURCE CATEGORY**

Primary: ISTF / Other: MF.

**LOCATION**

BAE SYSTEMS, Military Air Solutions, Warton, Lancashire, UK.

**NARRATIVE DESCRIPTION**

The Electromagnetic Test Capability spans the disciplines of EM Hazards (EMC/EMI), Lightning strike simulation, Signatures (RCS/IRS) and Installed Antenna Testing. To allow realistic full threat testing of whole aircraft platforms the ISTF includes a dedicated outdoor High Intensity RF (HiRF) Radio Environment Generator (REG) facility, a low power CW swept illumination facility for platform characterisation, a RF- and laser-shielded anechoic chamber (used for both HiRF and lightning strike testing), along with an outdoor RCS range. Additionally a range of smaller laboratories, some RF screened, are available for component and sub-systems testing.



(Images © BAE Systems 2011, all rights reserved)

The key benefit of most of the facilities is the ability to ‘drive in’ fully integrated platforms, from small UAVs to large combat aircraft. In particular the ability for many of the facilities to support platforms fully powered with ‘live’ Flight Control Systems and engines on, provides the most representative ground test environment. The figures show tests being performed in the various test facilities. The majority of the test capability has been developed with mobility in mind and testing has been performed around the World. With this mobility it is possible to test larger platforms on open field sites, customer bases and in hangars.

With this mobility it is possible to test larger platforms on open field sites, customer bases and in hangars.



**CAPABILITY SUMMARY**

<p><b>EM Hazards EMH/EMI</b></p> <p><b>REG Facility Equipment</b></p> <p>16 kW solid state 10 kHz – 200 MHz CW amplifier          1 kW solid state 100 – 1000 MHz CW amplifier</p> <ul style="list-style-type: none"> <li>• Up to 50 V/m 5 – 30 MHz (at 15 m)</li> <li>• &gt; 200 V/m 30 – 200 MHz (at 5 m)</li> <li>• &gt; 450 V/m 200 MHz – 1 GHz (at 1 m)</li> <li>• Targets up to 15 m</li> </ul> <p><b>Microwave Test Capability</b></p> <table border="1" style="width: 100%; border-collapse: collapse;"> <thead> <tr> <th colspan="4">Minimum CW Capability</th> </tr> <tr> <th>Frequency (GHz)</th> <th colspan="3">Minimum Field Strength Level (V/m)</th> </tr> </thead> <tbody> <tr> <td align="center">1 – 18</td> <td align="center" colspan="3">614</td> </tr> </tbody> </table> <table border="1" style="width: 100%; border-collapse: collapse;"> <thead> <tr> <th colspan="4">Minimum Pulsed RF Capability</th> </tr> <tr> <th>Frequency (GHz)</th> <th>Peak Field (V/m)</th> <th>PRF (kHz)</th> <th>Pulse Width (µs)</th> </tr> </thead> <tbody> <tr> <td align="center">1 – 2</td> <td align="center">2000</td> <td align="center">1</td> <td align="center">30</td> </tr> <tr> <td align="center">2 – 4</td> <td align="center">3883</td> <td align="center">1</td> <td align="center">25</td> </tr> <tr> <td align="center">4 – 8</td> <td align="center">3883</td> <td align="center">1</td> <td align="center">25</td> </tr> <tr> <td align="center">8 – 12.4</td> <td align="center">5000</td> <td align="center">1</td> <td align="center">30</td> </tr> <tr> <td align="center">12.4 – 18</td> <td align="center">2000</td> <td align="center">1</td> <td align="center">30</td> </tr> </tbody> </table> <ul style="list-style-type: none"> <li>• Low Level Swept Characterisation (LLSC) 2 MHz – 400 MHz</li> <li>• Bulk Current Injection (BCI) 2 – 400 MHz</li> <li>• Bay attenuation 200 MHz – 18 GHz</li> </ul>	Minimum CW Capability				Frequency (GHz)	Minimum Field Strength Level (V/m)			1 – 18	614			Minimum Pulsed RF Capability				Frequency (GHz)	Peak Field (V/m)	PRF (kHz)	Pulse Width (µs)	1 – 2	2000	1	30	2 – 4	3883	1	25	4 – 8	3883	1	25	8 – 12.4	5000	1	30	12.4 – 18	2000	1	30	<p><b>Signatures (RCS/IRS)</b></p> <p><b>RCS Measurement Range</b></p> <ul style="list-style-type: none"> <li>• 2 – 18 GHz frequency coverage</li> <li>• Full polarisation H, V and cross-polar</li> <li>• Absolute RCS data, 1D and 2D imagery</li> <li>• Platforms/targets up to 35 tonnes</li> <li>• Targets up to 15 m in extent</li> <li>• 7 m tall, 12 tonne Az/EI low-RCS positioner</li> </ul> <p><b>Mobile RCS Measurement System</b></p> <ul style="list-style-type: none"> <li>• 2 – 18 GHz frequency coverage</li> <li>• Test articles from component to whole body targets of 12 m in size</li> <li>• Measure target in early and mid lifecycle, production stage and in service</li> </ul> <p><b>IRS Measurements</b></p> <ul style="list-style-type: none"> <li>• MWIR (1.5 – 5.5 µm) and LWIR (7 – 11.5 µm) thermal imaging cameras</li> <li>• Measurements from -20°C to +1500°C</li> <li>• Ground-to-ground, ground-to-air, air-to-ground and air-to-air capabilities</li> <li>• Building/industrial equipment thermal surveys</li> </ul> <p><b>Installed Antenna Pattern Measurements</b></p> <ul style="list-style-type: none"> <li>• Use of outdoor RCS range</li> <li>• 360 degrees turntable</li> <li>• Performance verification of:             <ul style="list-style-type: none"> <li>• Direction of Arrival (DoA)</li> <li>• Effective Radiated Power (ERP)</li> </ul> </li> </ul>
Minimum CW Capability																																									
Frequency (GHz)	Minimum Field Strength Level (V/m)																																								
1 – 18	614																																								
Minimum Pulsed RF Capability																																									
Frequency (GHz)	Peak Field (V/m)	PRF (kHz)	Pulse Width (µs)																																						
1 – 2	2000	1	30																																						
2 – 4	3883	1	25																																						
4 – 8	3883	1	25																																						
8 – 12.4	5000	1	30																																						
12.4 – 18	2000	1	30																																						
<p><b>Lightning Strike Simulation</b></p> <ul style="list-style-type: none"> <li>• Any arbitrary shot amplitude from 200 kA full threat down to 20 kA sub-full threat</li> <li>• Aircraft return conductor solutions up to 40 m x 40 m</li> <li>• Anechoic chamber solution for platforms up to 16 m wide and 12.5 m high</li> </ul>	<p><b>Microwave Materials Measurement</b></p> <ul style="list-style-type: none"> <li>• 100 MHz – 20 GHz frequency coverage</li> <li>• Co- and cross-polarisations, complex relative permeability and permittivity, reflectivity</li> <li>• S-parameters and surface wave attenuation</li> <li>• 7 mm co-axial, free-field focussed beam, open-ended co-axial probe and NRL arch</li> </ul>																																								

**POINT OF CONTACT (EMH/EMI)**

Mr. Neil Ritchie  
 EMTG Group Leader  
 Building W423A  
 BAE Systems, Military Air Solutions  
 Warton Aerodrome  
 Warton, Lancashire PR4 1AX, UK  
 Tel: +44-(0)1772-855177  
 Fax: +44-(0)1772-855262  
 Email: [Neil.Ritchie@Baesystems.Com](mailto:Neil.Ritchie@Baesystems.Com)

**POINT OF CONTACT (RCS/IRS)**

Mr. Allan Brown  
 Electromagnetic Signatures Group Leader  
 Building W423A  
 BAE Systems, Military Air Solutions  
 Warton Aerodrome  
 Warton, Lancashire PR4 1AX, UK  
 Tel: +44-(0)1772-855570  
 Fax: +44-(0)1772-855262  
 Email: [Allan.D.Brown@baesystems.com](mailto:Allan.D.Brown@baesystems.com)

**A.6.5 Anechoic Shielded Chamber**

**TEST RESOURCE CATEGORY**

Primary: ISTF / Other: MF.

**LOCATION**

Alenia Aeronautica S.p.A., Caselle South Plant, Turin, ITALY.

**NARRATIVE DESCRIPTION**

The Anechoic Shielded Chamber (ASC) is the Alenia Aeronautica state-of-the-art testing facility designed to perform Electromagnetic Compatibility measurements and High Radio Frequency (RF) Sensitivity tests in a protected environment from both RF external noise and adverse weather conditions.

The Anechoic Shielded Chamber is a fully anechoic facility that allows to perform, in a controlled environment, both Intra- and Inter-system, such as EMC and High Intensity Radiated Field verification, in a representative environment of free-space, i.e., equivalent to actual flight conditions, and according to applicable civil and military standards.

The ASC is also provided with equipment for performing Antenna Radiation Pattern measurements and is suitable for Electronic Warfare (EW) tests.

The Anechoic Shielded Chamber is included in the same Host Building with another major facility: the Sky Light Simulator, the most advanced aerospace lighting laboratory in the world.

The Anechoic Shielded Chamber is composed of four shielded environments: an Anechoic Shielded Chamber (ASC), a Shielded Control Room/Amplifier Room 1 (SCR/AR1), an Electronic Warfare Chamber (EWC) and a Reverberating Chamber.

A Preparation Room located in front of the ASC Main Access Door, represents a protection against atmospherics and a comfortable area for aircraft setting up before the test campaign.

Remote management of the Anechoic Shielded Chamber is possible inside the Shielded Control Room (SCR) where the test execution in comfortable, automatic and safe condition is assured by: HIRF power generation control and monitoring system, CCTV system equipped with five cameras installed at different height and an infrared camera.

The Anechoic Shielded Chamber is designed to perform EMC/HIRF and RF testing on fighter aircraft as Eurofighter, Tornado, M-346 but it is also suitable for: small civil aircraft, rotorcraft, spacecraft, EW pod



and weapon system such as missile, ground vehicle and system. Moreover, the Anechoic Shielded Chamber is approved by the IT NSA as a TEMPEST test facility for platform/system.

**CAPABILITY SUMMARY**

<p><b>Anechoic Shielded Chamber</b></p> <ul style="list-style-type: none"> <li>• Anechoic chamber and several shielded test laboratories</li> <li>• Offices, conference rooms</li> <li>• Secure facilities (tailored to program requirements)</li> </ul>	<p><b>Chamber Dimensions</b></p> <ul style="list-style-type: none"> <li>• Shield: 30 m long x 30 m wide x 20 m high</li> <li>• RAM-tip to RAM-tip: 26 m x 26 m x 16 m</li> <li>• Main door: 18 m wide x 8.5 m high</li> <li>• One 2.5 m wide x 2.5 m access door</li> <li>• One human-sized access door</li> </ul>
<p><b>Shielding</b></p> <ul style="list-style-type: none"> <li>• Shielding &gt; 100 dB from 200 kHz to 18 GHz</li> <li>• TEMPEST grade, fully welded shield</li> <li>• Quiet zone 10 m diameter, 6 m high</li> <li>• Anechoic frequency range: 30 MHz -18 GHz</li> </ul>	<p><b>Support Services</b></p> <ul style="list-style-type: none"> <li>• 30 ton 10 m diameter turntable can rotate the system under test +/- 180 degrees up to 1 deg/sec.</li> <li>• One 25-ton hoist</li> <li>• Aircraft electrical power: <ul style="list-style-type: none"> <li>• 400 Hz, 115 VDC, 3Ø (General)</li> </ul> </li> <li>• Instrumentation power: 28 VDC, etc.</li> <li>• Cooling air system</li> <li>• Hydraulic system</li> </ul>
<p><b>EMI/HIRF</b></p> <ul style="list-style-type: none"> <li>• 10 kW solid state 9 kHz – 100 MHz CW amplifier</li> <li>• 4 kW solid state 100 MHz – 1000 MHz CW amplifier</li> <li>• 1 kW solid state 1 – 18 GHz CW amplifiers</li> <li>• 2 kW TWT 1 – 18 GHz PW amplifiers</li> <li>• Low Level Swept Characterisation (LLSC) 30 MHz – 400 MHz</li> <li>• Bulk Current Injection (BCI) 10 kHz – 400 MHz</li> <li>• Low level swept field/bay attenuation 30 MHz – 40 GHz</li> <li>• Emission radiated and conducted test 2 MHz – 18 GHz</li> </ul>	<p><b>Installed Antenna Pattern Measurements</b></p> <ul style="list-style-type: none"> <li>• NF-FF test facility using spherical</li> <li>• Performance verification of: <ul style="list-style-type: none"> <li>• Effective Radiated Power (ERP)</li> </ul> </li> </ul> <p><b>Microwave Materials Measurement</b></p> <ul style="list-style-type: none"> <li>• 100 MHz – 20 GHz frequency coverage</li> <li>• Co- and cross-polarisations, complex relative permeability and permittivity, reflectivity</li> <li>• S-parameters and surface wave attenuation</li> </ul>

**POINT OF CONTACT**

Mr. Ilario Bertino  
Engineering, Avionic Systems and Laboratories – ASYS  
Electromagnetic Environmental Effects Manager  
Alenia Aeronautica S.p.A.  
Strada Malanthero, 10072 Caselle Torinese (TO) – ITALY  
Tel: +39 011 9960446; Fax: +39 011 9960502  
Mobile: +39 366 6813929  
Email: [ibertino@alenia.it](mailto:ibertino@alenia.it)  
A Finmeccanica Company

**A.6.6 Electromagnetic Open Area Test Sites**

**TEST RESOURCE CATEGORY**

Primary: ISTF / Other: MF.

**LOCATION**

Alenia Aeronautica S.p.A., Caselle South Plant, Turin, ITALY.

**NARRATIVE DESCRIPTION**

The **Electromagnetic Test Centre** is mainly involved in ElectroMagnetic Compatibility / High Intensity Radiated Field (**EMC/HIRF**) qualification and certification of aircraft products that Alenia Aeronautica designs autonomously, such as the last generation of UAV technological demonstrators Sky-X and Sky-Y or, more frequently, in partnership with other national or international aerospace industries. The most recent aircraft like C-27J Spartan, Eurofighter Typhoon and Alenia Aermacchi M-346 have been tested and certified by Alenia’s Electromagnetic Test engineers using the **Open Area Test Sites** with proprietary test instrumentation.

The main activities of the Alenia Aeronautica **Electromagnetic Test Centre** are: to evaluate the electromagnetic compatibility and susceptibility aspects in system integration, to test and verify the satisfaction of EMC and HIRF requirements of complex platform, to perform final tests to demonstrate the fulfilment of International Standard requirements for Certification purposes, to test and check the RF performance of sub-systems integrated into air vehicle (e.g., navigation aids equipment), to test and check the performance of emitter devices directly installed on the aircraft (e.g., antenna radiation pattern), to support the testing activities defining the appropriate test instrumentation and facilities based on new testing requirements, to deal with EMC issues developing dedicated test instrumentation, new facilities and/or testing methods, with the aim to keep the technical know-how updated at the state-of-the-art.

The **EMC Test Range** is a dedicated open area (around 5,400 m<sup>2</sup>) including two circular test areas of 15 m diameter for vertical and horizontal polarization HF radiation; the **EMC Test Range** is equipped with a turntable platform that allows full 360° aircraft rotation.

The **Transport Test Area** was built at the beginning of 2001 specifically for the certification of the C-27J transport





aircraft. The result is a dedicated open area (50 m x 50 m), in which it was possible to perform the EMC tests with and without engines running that supported the civil certification of the C-27J in June 2001.

Various **Mobile Test Stations** are working in both OATS, each provided with RF instrumentation, tools and PCs to conduct EMC/HIRF testing in flexible, comfortable and safe manner.

Both Open Area Test Site are equipped with all the necessary ancillary system to provide electrical and hydraulic feed to air vehicles during the measurement campaign.

**CAPABILITY SUMMARY**

<p><b>Open Area Test Site:</b></p> <ul style="list-style-type: none"> <li>• Three testing locations for both horizontal and vertical polarization</li> <li>• Offices, conference rooms</li> </ul>	<p><b>Test Site Dimensions:</b></p> <ul style="list-style-type: none"> <li>• EMC Test Range: 5400 m<sup>2</sup> with two testing locations</li> <li>• Transport test aircraft range: 50 m x 50 m</li> </ul>
<p><b>EMI/HIRF:</b></p> <ul style="list-style-type: none"> <li>• 20 kW solid state 1 – 30 MHz CW amplifier</li> <li>• 10 kW solid state 9 kHz – 100 MHz CW amplifier</li> <li>• 4 kW solid state 100 MHz – 1000 MHz CW amplifier</li> <li>• 1 kW solid state 1 – 18 GHz CW amplifiers</li> <li>• 2 kW TWT 1 – 18 GHz PW amplifiers</li> <li>• Low Level Swept Characterisation (LLSC) 1 MHz – 400 MHz</li> <li>• Bulk Current Injection (BCI) 10 kHz – 400 MHz</li> <li>• Low level swept field / bay attenuation 1 MHz – 40 GHz</li> <li>• Emission radiated and conducted test 2 MHz – 18 GHz</li> </ul>	<p><b>EMC Test Range Support Services</b></p> <ul style="list-style-type: none"> <li>• 30 ton 8 m diameter turntable can rotate the system under test +/- 180 degrees up to 1 deg/sec.</li> <li>• One 25-ton hoist</li> <li>• Aircraft electrical power: <ul style="list-style-type: none"> <li>• 400 Hz, 115 VDC, 3Ø (General)</li> </ul> </li> <li>• Instrumentation power: 28 VDC, etc.</li> <li>• Hydraulic system</li> <li>• Ground plane</li> <li>• Wooden platform (h 3.0 m)</li> <li>• Fixed antennas (5 ÷ 30 MHz)</li> <li>• Mobile antennas (30 MHz ÷ 40 GHz)</li> <li>• Shielded test stations</li> </ul> <p><b>Transport Test Range Support Services</b></p> <ul style="list-style-type: none"> <li>• Aircraft electrical power: <ul style="list-style-type: none"> <li>• 400 Hz, 115 VDC, 3Ø (General)</li> </ul> </li> <li>• Instrumentation power: 28 VDC, etc.</li> <li>• Hydraulic system</li> <li>• Dedicated trolley for aircraft rotation</li> <li>• Fixed antennas (2 ÷ 30 MHz)</li> <li>• Mobile antennas (30 MHz ÷ 40 GHz)</li> <li>• Shielded test stations</li> </ul>

**POINT OF CONTACT**

Mr. Ilario Bertino  
Engineering, Avionic Systems and Laboratories – ASYS  
Electromagnetic Environmental Effects Manager, Alenia Aeronautica S.p.A.  
Strada Malanghero, 10072 Caselle Torinese (TO) – ITALY  
Tel: +39 011 9960446; Fax: +39 011 9960502; Mobile: +39 366 6813929  
Email: [ibertino@alenia.it](mailto:ibertino@alenia.it)  
A Finmeccanica Company

## ANNEX A – ELECTRONIC WARFARE T&E FACILITY DESCRIPTIONS

### A.6.7 USAF Joint Pre-Flight Integration of Munitions and Electronic Systems (J-PRIMES)

#### TEST RESOURCE CATEGORY

Primary: Installed Systems Test Facility (ISTF).

#### LOCATION

Eglin AFB, FL, USA.

#### NARRATIVE DESCRIPTION

The J-PRIMES anechoic chamber, as an Installed Systems Test Facility (ISTF), provides testing of air-to-air and air-to-surface munitions and electronics systems on full-scale aircraft and land vehicles prior to open air testing. Through simulation and modelling, vast amounts of performance data can be obtained at a fraction of the time and cost of conventional flight test programs alone.



(Image: USAF/Samuel King Jr.)



**CAPABILITY SUMMARY****J-PRIMES Provides The Following Major Test Areas:****RF Anechoic Chamber**

- 100 dB RF-isolated anechoic chamber with a hoist lift capacity of 40 tons and capable of testing all current USAF, USA, and USN fighter aircraft and helicopters, a variety of ground combat vehicles, and numerous commercial platforms

**Outdoor Ramp**

- Open-air flight line area for testing of large aircraft, with access to all facility simulation and instrumentation

**Test Stations**

- Shielded laboratories for sub-system level testing of fighter and bomber electronics and weapon systems

**EMI/EMC Chamber**

- Semianechoic shielded enclosure for testing of MIL-STD 461/462 and many other EMI/EMC commercial specifications

**J-PRIMES Instrumentation Includes:**

- AMES II for simulation of threat radar signals
- Four target, closed loop radar target simulator with dynamic radar cross-section, jet engine modulation, electronic countermeasures, and clutter signatures used to simulate threat engagement scenarios
- MIL-STD-1760 weapons and aircraft simulator for interfacing with aircraft systems
- Two 10-channel differential GPS constellation and GPS jammers

**POINT OF CONTACT**

J-PRIMES

46 RANG/TSPA

401 W. Choctawhatchee Avenue, Suite 263

Eglin AFB, FL 32542-5724, USA

Tel: 850-882-8472 or 850-882-8102

DSN: 872-8472 or 872-8102

Fax: 850-882-8162

**A.6.8 CASSIDIAN EME Test Facility**

**TEST RESOURCE CATEGORY**

Primary: ISTF: Whole System EM Testing.

**LOCATION**

CASSIDIAN, Manching, GERMANY.

**NARRATIVE DESCRIPTION**

The Cassidian EME Test Facility is a full threat level, 5 – 30 MHz HIRF test facility and provides individually tailored testing for EME qualification, verification and certification support for military and civil customers, for large and operational systems.

EME testing is performed according to national, international, military, NATO and civil standards, as well as customer defined requirements. Supporting activities such as test definition, test vehicle monitoring and data evaluation are available.

An RF transparent, rotatable, heavy duty wooden lifting platform is available to eliminate ground effects and to ensure a large and homogeneous test volume. Additionally, mobile HIRF test facilities up to 18 GHz are available, to support on site testing at customer locations. The facility has excellent antenna decoupling and interference measurement capabilities. State-of-the-art Test Equipment is used throughout.

EM Testing is typically performed when the certification authorities require re-testing due to modifications on a system (e.g., due to changes in cabling, new electronic/electrical equipment, changes due to obsolescence), or when a type certification of a system or sub-system is required by the certification authorities, or when an engineering test is required to reduce the risk due to EMC related failures, as well as when EMC failures have occurred during normal operation.

Some of the systems already tested include the Eurofighter TYPHOON, the Panavia TORNADO, the F-4F PHANTOM, the C-160 TRANSALL, the P-3C ORION CUP, as well as the NH90 TTH and the CH53GA helicopters.

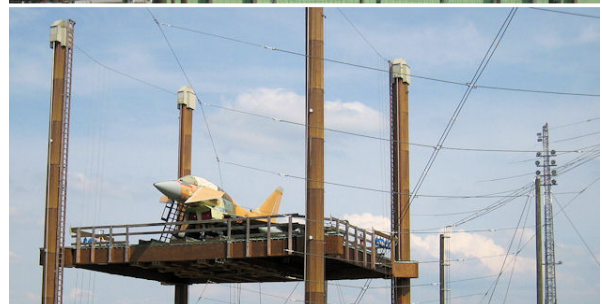

**CAPABILITY SUMMARY****Application Examples**

- Small to large system testing, with mobile test equipment
- Type certification for German flight clearance authorities (ML)
- Shielding effectiveness measurement of all kinds of objects
- Conducted and radiated emission measurements of all kinds of objects, including with running engines
- Antenna pick up, noise, phase decoupling and installed performance measurements
- Direct (DCI) or indirect current injection into all kinds of structures

**Electromagnetically Transparent Wooden Elevation Platform:**

- Raising of test objects up to 20 m into the homogenous zones of horizontal polarized EM fields
- Platform load max. 30 t, turn range  $\pm 182^\circ$
- Large test volume: Vertical polarised (40(l) x 35(b) x 12(h) m); Horizontal polarised 20 x 15 x 6 m

**HIRF Test Capabilities**

- 5 – 30 MHz up to 250 V/m (100 kW)
- 30 – 500 MHz up to 250 V/m (2 – 5 kW)
- 0,5 – 1 GHz up to 650 V/m (2 kW)
- 0,8 – 18 GHz up to 1000 V/m (350 W)

**Direct Current Injection (DCI)**

- To support low frequency HIRF testing on complex systems

**Low Level Swept Current (LLSC) Testing**

- 1 – 400 MHz, 64 current probes in parallel, ultra fast measurement technique

**Low Level Swept Field (LLSF) Testing**

- 5 MHz – 18 GHz, up to 12 field probes in parallel

**Bulk Current Injection (BCI)**

- 10 kHz – 400 MHz, multi-injection

**Enhanced Level Injection into onboard sensors**

- 10 kHz – 18 GHz, all modulation types

**Standards**

- All IEC, EN, DIN standards
- All MIL-STDs
- All VG standards
- All STANAG standards
- Customer specific

**POINT OF CONTACT**

CASSIDIAN  
Rechliner Straße  
85077 Manching  
GERMANY  
Tel: +49 (0) 84 59 81 – 6 41 34  
Email: [harald.werner@cassidian.com](mailto:harald.werner@cassidian.com)

## **A.7 OPEN AIR RANGES, INCLUDING EW T&E FLIGHT TEST CAPABILITIES**

### **A.7.1 Electronic Combat Range**

#### **TEST RESOURCE CATEGORY**

Primary: OAR / Other: HITL.

#### **LOCATION**

China Lake, California, USA.

#### **NARRATIVE DESCRIPTION**

The Electronic Combat Range (ECR) is physically located in California at China Lake's South Range and provides a realistic electronic combat environment. ECR provides threat systems; operations and range control; instrumentation; Time, Space, Position Information (TSPI), telemetry, optical and communications; data processing and display systems; and signal monitoring, calibration systems and assessment and repair facilities for test and evaluation and training customers. The ECR is the Navy's principle open-air range for test and evaluation of electronic combat systems.

#### **Threat Simulations**

The ECR offers a wide variety of threat simulations, surrogates and actual systems, providing a threat-rich environment. The 1,200 square miles of restricted airspace overlying 900 square miles of Navy land offer ample room for either single- or multi-platform events.

Open-air hardware-in-the-loop testing at the ECR helps bridge the gap between laboratory and open-air testing. Long before a system is ready for flight testing, the hardware can be tested against an assortment of threat systems and advanced technology simulators.



Multiple threat systems are available: actual, surrogate and simulated. A broad range of EW technologies are offered: pulse, continuous wave, Doppler, multi-spectral, and Blue and Gray systems. Test emitter spectrums include radio frequency, electro-optical and millimeter wave. All systems use audio and video instrumentation to collect extensive digital flight test data.

#### **Test Support**

At ECR, aircrew have the opportunity in a single mission to combat both an air-to-air threat and a surface-to-air threat as well as complete an air-to-ground strike mission.

Top secret and special-access level security is available with minimum electromagnetic interference. ECR supports a combination of land and naval systems (littoral threat). The ECR provides engineering support, developmental and operational test and evaluation, analysis, and training resources for users of systems that counter or penetrate air defences.

**CAPABILITY SUMMARY**

<p><b>Types of Events</b></p> <ul style="list-style-type: none"> <li>• Electronic Countermeasures (ECM) effectiveness testing</li> <li>• Radar Warning Receiver (RWR) testing</li> <li>• Unmanned Aerial Systems (UASs)</li> <li>• Expendables – chaff and flare effectiveness</li> <li>• Towed and air launch decoy testing</li> <li>• Anti-Radiation Missile (ARM) flight testing to evaluate seekers and avionics</li> <li>• Tactics development</li> <li>• Training</li> </ul>	<p><b>Technologies</b></p> <ul style="list-style-type: none"> <li>• Pulse systems</li> <li>• Continuous wave systems</li> <li>• Pulse Doppler systems</li> </ul>
<p><b>Data Outputs</b></p> <ul style="list-style-type: none"> <li>• Scope video</li> <li>• Boresight video</li> <li>• Display video</li> <li>• Radio recordings</li> <li>• Crew hot mike recordings</li> <li>• Digital data</li> <li>• Raw unprocessed data</li> <li>• Sorted corrected data (wild point flags and sorted by time)</li> </ul>	<p><b>Systems Provided</b></p> <ul style="list-style-type: none"> <li>• Advanced threat simulations</li> <li>• Surrogates</li> <li>• Red, blue, and gray threat assets</li> </ul>

**POINT OF CONTACT**

Electronic Threat Systems  
 7000 Randwash Road  
 China Lake, CA 93555, USA  
 Tel: 760-939-5303  
[www.navair.navy.mil/ranges](http://www.navair.navy.mil/ranges)



### **A.7.2 Vidsel EW Test Range**

#### **TEST RESOURCE CATEGORY**

Primary: OAR / Other: EW-Training Range.

#### **LOCATION**

Vidsel Test Range is located in the northern part of Sweden, almost on the Arctic Circle and close to Vidsel Airbase (ESPE).

#### **NARRATIVE DESCRIPTION**

Vidsel Test Range is operated by the Swedish Defence Materiel Administration (FMV) and is best known for its large overland capability and for its weapon employments. At Vidsel Test Range it is possible to undertake Air-to-Air firing with large stand-off weapons, to employ various live bombs and also to operate UAV flights.



In recent years EW has become a key factor in the development of the range. During the NATO Loyal Arrow exercise (2009) and in other international air exercises Vidsel Test Range has provided realistic EW threats. Since Vidsel Test Range and the surrounding Restricted Area is so large, vertically and horizontally, it's very well suited for large scale training or for tests that require large space.

The Swedish Armed Forces have performed tactical testing at Vidsel of their equipment and flight crews against IR/UV threat simulators.

Foreign air forces have conducted a tactical EW-training course with helicopters at Vidsel Test Range using generic RF threats as well as IR/UV simulators.

The Swedish aircraft industry has also used IR/UV simulators to do tests of Missile Approach Warning Systems (MAWS).



**CAPABILITY SUMMARY**

<p><b>Range Area</b></p> <ul style="list-style-type: none"> <li>The total range area where we can employ weapons is approximately 35 x 70 km and this area can be evacuated if needed.</li> </ul>	<p><b>Airspace</b></p> <ul style="list-style-type: none"> <li>The Airspace (Restricted Area / ESR02) surrounding the range area is approximately 70 x 120 km laterally and unlimited vertically. Vidsel Test Range ‘owns’ the airspace which makes it possible to use the air very flexibly.</li> </ul>
<p><b>Infrastructure</b></p> <ul style="list-style-type: none"> <li>Vidsel Test Range has excellent infrastructure with fibre and RF links, networks, road networks, electrical power networks, airfield, range instrumentation systems and much more. There is also a structure in which different kinds of threat systems can be connected in many various locations. This structure is connected to a real-time control system, VIEWS by CAS, UK, in the main mission control center. Post mission evaluation (quick feedback to air crews) is also done in/with this system.</li> </ul>	<p><b>Airbase</b></p> <ul style="list-style-type: none"> <li>Vidsel Test Range is supported by Vidsel Airbase (ESPE) located approximately 30 km from the southeast corner of the Range Area. The airbase is fully operational with a 7300 ft runway equipped with an arresting cable.</li> </ul>
	<p><b>IR/UV</b></p> <ul style="list-style-type: none"> <li>Vidsel Test Range has two Mallina systems which simulate IR/UV threats (SA-7). These simulators are very flexible for use as tactical threats and can also be used to verify MAWS and flare systems.</li> </ul>
<p><b>RF</b></p> <ul style="list-style-type: none"> <li>Vidsel Test Range can offer three tracking radar units as generic RF-emitters for testing or tactical training.</li> </ul>	<p><b>Flares</b></p> <ul style="list-style-type: none"> <li>Vidsel Test Range allows the use of flares at all levels in the range area (depending on the level of fire hazard).</li> </ul>
<p><b>Chaff</b></p> <ul style="list-style-type: none"> <li>Vidsel Test Range allows the use of chaff.</li> </ul>	<p><b>EW-Jamming/GPS-Jamming</b></p> <ul style="list-style-type: none"> <li>Vidsel Test Range allows EW and GPS jamming (subject to approval from the authorities).</li> </ul>

**POINT OF CONTACT**

Mr. Per Nilsson  
 EW Co-ordinator, Vidsel Test Range  
 Vidsel  
 Lapland SE-94295  
 SWEDEN  
 Tel: +46 929 37103  
 Email: [pelle.nilsson@fmv.se](mailto:pelle.nilsson@fmv.se)

**ANNEX A – ELECTRONIC WARFARE T&E FACILITY DESCRIPTIONS**

**A.7.3 Center for Countermeasures (CCM)**

**TEST RESOURCE CATEGORY**

Primary: OAR / Other: N/A.

**LOCATION**

White Sands Missile Range, New Mexico, USA.

**NARRATIVE DESCRIPTION**

The Center for Countermeasures (CCM) directs, coordinates, supports and conducts independent Countermeasure (CM) / Counter-Countermeasure (CCM) test and evaluation activities for U.S. and foreign weapon systems, sub-systems, sensors and related components. We are a tenant organization at White Sands Missile Range and report to and receive guidance and funding from the Office of the Secretary of Defense, Director, Operational Test and Evaluation.

The Center supports all of the Services and other federal agencies in their test activities by having world-class organization for open air IRCM T&E, providing Survivability Equipment (SE) with an emphasis on rotary and fixed wing platforms, providing Hostile Fire (HF) data collection and activity coordination, and offering threat injection during pre-deployment events.

The Center provides many unique capabilities including mobile, self-sufficient T&E equipment; zero labor cost providing significant savings to the program; independent CM/CCM assessments at anytime in the program’s acquisition cycle; and establish and maintain US-NATO survivability memorandums of agreement.

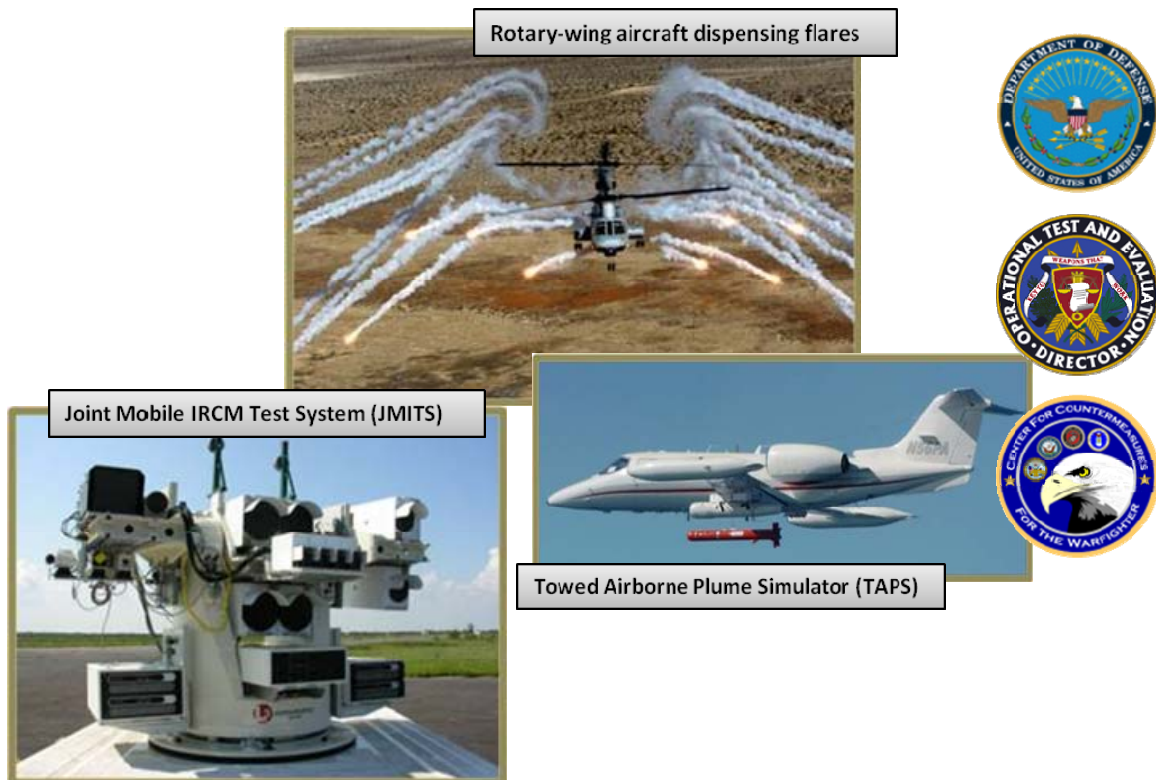

**CAPABILITY SUMMARY**

<p><b>Types of Events:</b></p> <ul style="list-style-type: none"> <li>• Independent counter-countermeasure test and evaluation</li> <li>• Zero labor cost providing significant savings to the program</li> <li>• Independent CM/CCM assessments at anytime in the program’s acquisition cycle</li> <li>• Establish and maintain US-NATO survivability memorandums of agreement</li> </ul>	<p><b>Technologies:</b></p> <ul style="list-style-type: none"> <li>• Threat injection during pre-deployment events</li> </ul>
<p><b>Data Outputs:</b></p> <ul style="list-style-type: none"> <li>• Hostile fire data collection</li> </ul>	<p><b>Systems Provided:</b></p> <ul style="list-style-type: none"> <li>• Mobile, self-sufficient T&amp;E equipment</li> <li>• Survivability equipment with an emphasis on rotary and fixed wing platforms</li> </ul>

**POINT OF CONTACT**

Center for Countermeasures  
Tel: 575-678-7200

## ANNEX A – ELECTRONIC WARFARE T&E FACILITY DESCRIPTIONS

### A.7.4 NATO Joint Electronic Warfare Core Staff

#### TEST RESOURCE CATEGORY

Primary: OAR / Other: N/A.

#### LOCATION

Main Operating Base is at RNAS Yeovilton, UK; however all assets are mobile and deployable as required throughout the NATO AOR.

#### NARRATIVE DESCRIPTION

NATO Joint Electronic Warfare Core Staff (JEWCS) has a number of functions including provision of a hostile EW environment in which to conduct training at the tactical and operational levels in the land, maritime and air environments for all NATO standing and assigned forces. (This includes a remit to support EW trials and experimentation). It also supports Operations, provides the NATO Emitter Database (NEDB) and provides NATO's core EW staff function, EW policy and doctrine.

The JEWCS EW training capability is applicable to EW T&E Flight Testing and can provide: Radar and communications emitter simulation, Radio communications intercept, jamming and deception, Radar jamming and deception, Datalink jamming and EMCON and COMSEC monitoring. These capabilities are provided by assets operating in the air sea and land environments, any of which could be utilised in Flight Testing. The fundamental difference between the JEWCS assets and those on a more traditional EW range is that the assets are all mobile or transportable and routinely deploy to the location required throughout the NATO AOR. It should be noted however that because of equipment limitations and training artificialities the power levels of the equipments are not calibrated and are not usually representative of operational systems.



A brief description of the EW assets is as follows:

- **EW Pods** – ALQ-167 pods which can be carried on contractor business jet type aircraft such as DA-20 Falcon or Learjet, or on suitably certified fast jets, currently only F18, F4 and Hawker Hunter. 8 radar simulation pods and 24 Jamming pods. Effective for both air to air and air to ground jamming and Simulation.
- **TRACSVANs** – (TV) Transportable Radar and Communications Jamming and Simulation Vans TV. Optimised for maritime EW but also usable in other scenarios. They are capable of simultaneous radar jamming, radar simulation, datalink jamming and communications jamming/deception. The TV can be deployed at sea on host-ships or can deploy on land operating off a transporter. Capable of ground to air, although for radar jamming and simulation it has very limited capabilities for optically tracking fast moving (airborne) targets.
- **MINI-RADARVAN (MRV)** – Vehicle capable of radar simulation and jamming, including DRFM. Capable against surface or airborne targets; however it is primarily intended for use against fixed surface targets, tracking capability is very limited.



- **SHORT RANGE AIR DEFENCE SITE SIMULATOR (SAD)** – Capable of simulating radars associated with Surface-to-Air Missile systems or Anti-Aircraft-Artillery systems. Targets are acquired and tracked visually through binoculars.
- **UV MALLINA SYSTEM (MALLINA)** – Capable of short range stimulation of UV Missile Warning Systems.
- **NATO EW VANS (NEWVAN – NV)** – Optimised for Land EW, but also usable for amphibious and air exercises. Provides Comms ESM, jamming and deception.
- **NI NEWVAN (MNV)** – Landrover-based capabilities similar to NV.
- **MOBILE INTERCEPT JAMMING ASSETS (MIJA)** – Off-road capable communications assets which can provide ESM intercept, jamming and deception.



**CAPABILITY SUMMARY**

- ALQ-167 pods.
- Simulation:
  - Banded frequency range: 7.8 to 17.5 GHz, PRF 200 – 6000, PW 0.1 to 2.0  $\mu$ Sec, stable, jittered and staggered PRF modes. Jamming: noise and coherent (DRFM) techniques. Banded frequency range: 0.85 to 17.2 GHz.
  - MRV radar simulation and jamming (non-coherent and coherent techniques) 0.85 GHz – 18 GHz. V/UHF comms.
  - SAD. Bands 7.8 – 8.5, 8.5 – 9.5 and 14.5 – 15.2 GHz. PRF 200 – 5500 (stable or random jitter or stagger).
  - UV Mallina. Library modes for test MAWS/DASS (AN/AAR-47, AN/AAR-54, AN/AAR-57, AN/AAR-60, MAW-200)
  - NEWVAN, Mini NEWVAN and MIJA. Surveillance/DF 2 – 1000 MHz, Jamming 2 – 1000 MHz (capabilities vary)

**POINT OF CONTACT**

Lt. F. Godot  
 Deployment Officer  
 NATO JEWCS  
 RNAS Yeovilton  
 Yeovil BA22 8HT  
 Somerset, UK  
 Tel: +44 (0)1935 842109  
 Fax: +44 (0)1935 841928  
 Email: [f.godot@jewcs.nato.int](mailto:f.godot@jewcs.nato.int)



## ANNEX A – ELECTRONIC WARFARE T&E FACILITY DESCRIPTIONS

### A.7.5 T&E Support for Aircraft Survivability

#### TEST RESOURCE CATEGORY

Primary: OAR / Other: N/A.

#### LOCATION

Eglin Air Force Base, Florida, USA.

#### NARRATIVE DESCRIPTION





The 46th Test Wing (46 TW) provides complete end-to-end Test and Evaluation (T&E) capability for aircraft self-protection systems and threat system performance in support of aircraft survivability and vulnerability studies.

Extensive target signature measurement capability provides calibrated data across the full electromagnetic spectrum and operational environment. Flexible airborne and ground instrumentation platforms allow measurement of all surface and airborne targets. These target signatures are used to develop and validate digital signature models for virtual missile to target engagements. For example, simulated Infrared (IR) and Electro-Optical (EO) target models can be developed using Spectral and In-band Radiometric Imaging of Targets and Scenes (SPIRITS), Composite Hard-body and Missile Plume (CHAMP), and Real-Time CHAMP (RTC) software. Red and blue missiles seekers can engage these virtual targets in a non-destructive HITL simulation. With extensive land and water ranges and a wide variety of test instrumentation assets, the 46 TW provides a unique open-air capability to evaluate sensors and seekers against real-world targets in realistic air, land, and sea background test and training scenarios. Open-air assets include the Missile Warning Sensor Stimulator, the Seeker Test Van, the STEF, and a variety of flight certified pod-based platforms. The 46 TW has a great deal of experience planning and conducting tests of aircraft self-protection systems against heat-seeking missiles, and has been an instrumental team member in almost all major IR protection programs including: the Large Aircraft IR Countermeasure System (LAIRCM), the Directed IR Countermeasure System (DIRCM), Advanced Threat IR Countermeasures System (ATIRCM), and Advanced Strategic Tactical Expendable Program (ASTE). These programs span self-protection applications across many diverse types of aircraft and operational users.

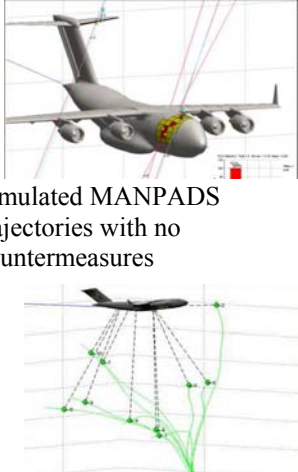

**CAPABILITY SUMMARY**

<p><b>SEEKER TEST VAN (STV)</b></p> <p>The Seeker Test Van (STV) is an aid in the development and exploitation of the Guidance and Control Units (GCUs) of ground-to-air and air-to-air missiles, the assessment of countermeasures effectiveness, techniques, and tactics in an open-air test environment.</p> <ul style="list-style-type: none"> <li>• Collects data on up to six GCUs simultaneously</li> <li>• Three seeker control stations (each controlling two seekers)</li> <li>• A data acquisition station, a video and data recording station, a data reduction station, and a mission control station</li> <li>• KTM has five mounting surfaces for seekers, visible cameras, Infrared (IR) cameras/radiometers, and a Mallina Missile Warning System (MWS) stimulator/simulator</li> <li>• Employs a missile roll fixture to create a realistic test scenario for rolling airframe missiles</li> </ul>	 <p>Typical instrumentation suite for testing aircraft missile warning systems</p>
<p><b>GUIDED WEAPONS EVALUATION FACILITY (GWEF)</b></p> <p>The GWEF provides multi-spectral simulations for test and evaluation of precision-guided weapons, threat systems, and countermeasure systems. A complete range of T&amp;E capability is available including digital simulation, HITL simulation, parametric measurements, countermeasure testing, and performance characterization assessment. The GWEF is the only facility of its kind able to test the complete spectrum of weapon seekers and sensors under one roof.</p> <ul style="list-style-type: none"> <li>• Digital and Hardware-In-The-Loop (HITL) simulations of air armament munitions</li> <li>• Parametric measurements</li> <li>• Countermeasure (CM) testing</li> <li>• Directed Energy (DE) countermeasure effectiveness testing against MANPADS</li> <li>• HITL testing incorporates full imaging capability of aircraft targets via leading edge technology of resistor arrays</li> <li>• Provides virtual test range for multi-mode sensors including millimeter wave, imaging infrared, and semi active laser</li> </ul>	 <p>Simulated MANPADS trajectories with no countermeasures</p> <p>Simulated MANPADS trajectories with active countermeasures</p>
<p><b>EGLIN MOBILE MISSILE LAUNCHER SYSTEM (EMMLS)</b></p> <p>EMMLS provides live launch capability for Man-Portable Air-Defence Systems (MANPADs) against real or simulated aircraft.</p> <ul style="list-style-type: none"> <li>• EMMLS consisting of a positioner, a control vehicle and a generator to power the system</li> <li>• EMMLS is capable of firing both foreign and domestic MANPADS</li> <li>• EMMLS operates both a generic positioner on a portable trailer for testing shoulder-fired MANPADS, and a simulated threat Transporter/Erector/Launcher (TEL) for larger surface-to-air missiles</li> <li>• The control van operates the launchers and can record missile diagnostic signals, position information, video (infrared and visible), referenced to IRIG time</li> </ul>	 <p>Live MANPADS launch from EMMLS</p>

**POINT OF CONTACT**

Mr. Jerry Griffith  
 Technical Director 782d Test Squadron  
 Tel: 850-882-9819, DSN 872-9819  
 Fax: 850-882-9929  
 Email: [jerry.griffith@eglin.af.mil](mailto:jerry.griffith@eglin.af.mil)

## ANNEX A – ELECTRONIC WARFARE T&E FACILITY DESCRIPTIONS

### A.7.6 Trials/Test Support Group

#### TEST RESOURCE CATEGORY

Primary: OAR / Other: Equipment and Personnel.

#### LOCATION

ESL Defence Ltd, 16 Compass Point, Ensign Way, Hamble, Southampton, Hampshire, UK.

#### NARRATIVE DESCRIPTION

The Trials/Test Support Group has extensive experience in operating long range Electro-Optical/Infrared (EO/IR) threat simulators to perform test and evaluation of Aircraft Survivability Equipment (ASE). This support is provided by Subject-Matter Experts to assist with the planning and operation of the threat emitters either those deployed on the open-range or leased as part of the support exercise.



The Trials/Test Support Group can also provide the service of data collection and data analysis and provide a Final Report from this data. One of the major contributors to the success of performing a test and evaluation exercise is to ensure that the probability of declaration from the various ASE sensors threat is high and if possible 100 percent. To achieve this high probability with today's high technology sensors requires a combination of representative missile signatures and operator experience in the understanding of the limitations of the threat emitter when fired at a moving target. The Trials/Test Support Group Engineers with their many years of international experience of stimulating many different types of missile warning system can provide the required expertise.



In addition, and perhaps of equal importance, is the performance of the EO/IR threat emitters. ESL has developed a comprehensive range of high fidelity long range threat emitters. These threat emitters include both UV and IR Emitters, known as Mallina and Phoenix, for the test and evaluation of UV and IR missile warners, laser warning receivers and for providing simulation of muzzle flash for the simulation of Hostile Fire Indicators. Further, by combining these threat emitters with additional EO/IR modules, including an IR Detector to measure the output from the DIRCM countermeasure, an end-to-end evaluation of a DIRCM system can be performed by what is known as the Mallina DIRCM Cluster. Further, the Trials/Test Support Group can provide a comprehensive set of flight line test sets that can test the aircraft just prior to the test and evaluation flight to ensure that the system under test is operating correctly.



UV LED Mallina



IR Phoenix



DIRCM Mallina Cluster

**CAPABILITY SUMMARY****Trials/Test Support Activities**

- The Trials Support Group comprises a number of subject-matter experts in simulation of missile and hostile fire for the simulation of aircraft survivability equipment. This support can be provided to operate either the open-range legacy equipment or ESL's comprehensive portfolio of threat emitters that can be provided on a lease basis. The support includes:
  - Pre-test and evaluation programme planning
  - Aircraft flight test path planning
  - Development of optimised missile profiles for use in the threat emitters
  - Operation of the threat emitters
  - Training of range operational staff
  - Trails data collection
  - Analysis of trials data
- In addition to the above, ESL can provide flight line test equipment to test the System Under Test (SUT) to establish just prior to the test flight, on a "Go/No-Go" basis, that the SUT is functioning correctly. The flight line test equipment portfolio comprises:
  - Solent – to test omni directional IR Jammer
  - UV and IR Baringa – to test UV and IR missile warners respectively
  - Hydra – to test laser warning receivers
  - MEON to perform an end-to-end test of a DIRCM system
  - Multi-spectral test set – to test ASE equipment that requires simultaneous multi-spectral stimuli

**Support Hardware and Software**

- The EO/IR threat emitters simulators available for lease comprise:
  - UV and IR Griffen – to stimulate UV and IR missile signatures at ranges in excess of 5 km
  - UV LED Mallina – to simulate UV missile warners and UV hostile fire indicators (muzzle flash only) at ranges in excess of 8 km
  - Red and Blue HP Phoenix – to simulate IR missile warners and IR hostile fire indicators (muzzle flash only) at ranges in excess of 3 km
  - IRM-16 IR Beacon and Detector Module – to provide an IR beacon for the DIRCM fine tracking system to lock on to and measure the characteristics of the DIRCM countermeasure beam
  - Mallina Laser Range Finder Module – to provide a means to establish the range of the SUT and if selected auto-selection of the appropriate profile for that range
  - Tripod Legs and Head – to support the threat emitters.
  - Threat Emitter Management Software Tools – to download profiles into the threat emitter and remotely operate the threat emitters from a Desk-top PC or Laptop
  - Missile Signature Development Tools – to provide missile signatures based on public domain missile data

**POINT OF CONTACT**

Mr. Keith Dalley  
Business Development Manager, ESL Defence Limited  
16 Compass Point, Ensign Way  
Hamble, Southampton  
Hampshire SO31 4RA, UK  
Tel: +44 (0) 2380 744272  
Fax: +44 (0) 2380 744200  
Email: [keith.dalley@esldefence.co.uk](mailto:keith.dalley@esldefence.co.uk)



## Annex B – MEASURES OF PERFORMANCE (MOPs)

### B.1 INTRODUCTION

This Handbook focuses on EW Developmental Test & Evaluation (DT&E) and consequently MOPs are the central metrics. It is important, however to understand how MOPs fit into the overall hierarchy of test requirements, objectives, and associated measures. It is also important to understand what a measurement is and what information it conveys. Finally, this annex discusses some common MOPs. It is not intended to be definitive or an exhaustive compilation. It is intended to make the reader think about what details need to be addressed and documented in the planning stages to avoid disagreements later in the programme when they are much more difficult to resolve.

### B.2 REQUIREMENTS, OBJECTIVES, AND MEASURES

Test requirements ultimately derive from operational needs identified by the military end user. These requirements are expressed as Critical Operational Issues (COI) and are defined as: “A key Operational Effectiveness (OE) and/or Operational Suitability (OS) issue (not a parameter, objective, or threshold) that must be examined in Operational Test and Evaluation (OT&E) to determine the system’s capability to perform its mission. A COI is normally phrased as a question that must be answered in order to properly evaluate OE (e.g., “Will the system detect the threat in a combat environment at adequate range to allow successful engagement?”) or OS (e.g., “Will the system be safe to operate in a combat environment?”). A COI may be decomposed into a set of Measures Of Effectiveness (MOE) and/or Measures Of Performance (MOP), and Measures of Suitability (MOS).” [1] Furthermore, the MOE, MOP, and MOS are defined as:

- **MOE:** Measure designed to correspond to accomplishment of mission objectives and achievement of desired results. MOEs may be further decomposed into Measures of Performance and Measures of Suitability. [2]
- **MOP:** Measure of a system’s performance expressed as speed, payload, range, time on station, frequency, or other distinctly quantifiable performance features. Several MOPs and/or Measures of Suitability may be related to the achievement of a particular Measure Of Effectiveness (MOE). [3]
- **MOS:** Measure of an item’s ability to be supported in its intended operational environment. MOSs typically relate to readiness or operational availability, and hence reliability, maintainability, and the item’s support structure. [4]

MOPs are most commonly encountered as contractual specification requirements or other DT&E requirements. Some examples include: response times, Angle Of Arrival (AOA) measurement error, maximum detection range, etc.

### B.3 MEASUREMENTS

One of the most important axioms in T&E is that system requirements must be testable. This means that the test must produce a meaningful answer to the questions asked. Whether or not a system meets its requirements will usually be determined by a measurement or series of measurements.

Measurement theory and statistics are complex fields and detailed treatments are beyond the scope of this Handbook. A measurement, by one definition, “in the broadest sense, is defined as the assignment of numerals to objects or events according to rules.” [5] While there is controversy among statisticians

## ANNEX B – MEASURES OF PERFORMANCE (MOPs)

regarding the four scales or classifications of measurement shown in Table B-1, they serve as a good starting point for a discussion of MOPs.

**Table B-1: Measurement Scales [6].**

Scale	Attributes	Permissible Statistics (Examples)	Common Examples
Nominal	Classification only.	Number of Cases, Mode	First Names
Ordinal	Rank ordered – the differences between the values are not meaningful.	Median, Percentile	Hardness of Minerals, Quality of Leather
Interval	Uses a scale with an arbitrary zero point (can have numbers less than zero) – differences between values are meaningful, but ratios of values are not meaningful, i.e., 60°F is not twice as “hot” as 30°F.	Mean, Standard Deviation, Correlation, Regression, Analysis of Variance	Fahrenheit or Celsius Temperature Scales
Ratio	Uses a scale with a non-arbitrary zero point (cannot have numbers less than zero) – ratios of values are meaningful, i.e., a weight of 20 lbs. is twice as much as 10 lbs.	All statistics permitted for interval scales plus the following: geometric mean, harmonic mean, coefficient of variation, logarithms	Rankin or Kelvin Temperature Scales

The individuals charged with generating specification requirements should consult with experienced testers and analysts. This ensures that types of measurements are appropriate to the task and that the required data can be collected in sufficient quantities and at sufficient rates. Proper consideration of the measurements and associated analysis techniques will not only help answer the question of whether or not a System Under Test (SUT) meets its specification requirements, but will also support a broader characterization of SUT performance.

Data analysts should strive to choose the measurement scale that retains the maximum amount of information. Information retention can be illustrated using bombing MOPs as an example. Consider a specification where a hit or miss is determined by a specified bomb miss distance (a nominal measurement). A significant amount of information is lost by just evaluating whether or not each bomb produces a hit or a miss. By focusing the analysis on vector miss distances (a ratio measurement); analysts can determine much about the system by analyzing the range and direction of the errors.

### B.4 MOP CONSIDERATIONS

Test designers must consider MOPs in light of how a SUT functions. As an example, consider the objective of evaluating the performance of a Radar Warning Receiver (RWR). The evaluation needs to address several different MOPs. The specification requirements will be expressed as MOPs.

In a perfect world, the system contractual specification requirements document would define not only the specific MOPs to be evaluated but also:



- The specific conditions under which the data will be collected.
- The data reduction, analysis, evaluation process, including statistical treatments.

Failure to address these considerations can cause unexpected variability in the results and possibly incorrect measurements and inaccurate results. The simplified case shown Figure B-1 illustrates how this can occur. The dwell structure shown could have a significant effect on the ability of the RWR to detect and identify radar A. If radar A is operating between 9.0 and 10.0 GHz the RWR doesn't need to make any decisions when a signal is detected; the measured frequency and Pulse Repetition Interval (PRI) are sufficient to make a unique identification. If, however, radar A is operating at 8.5 GHz the Mission Data File (MDF) has two other radars with which to contend. Assume that Radar B is ambiguous in frequency and PRI with radar A then the RWR will need to do additional processing to resolve the ambiguity; perhaps by determining scan type or rate or by a more detailed pulse analysis.

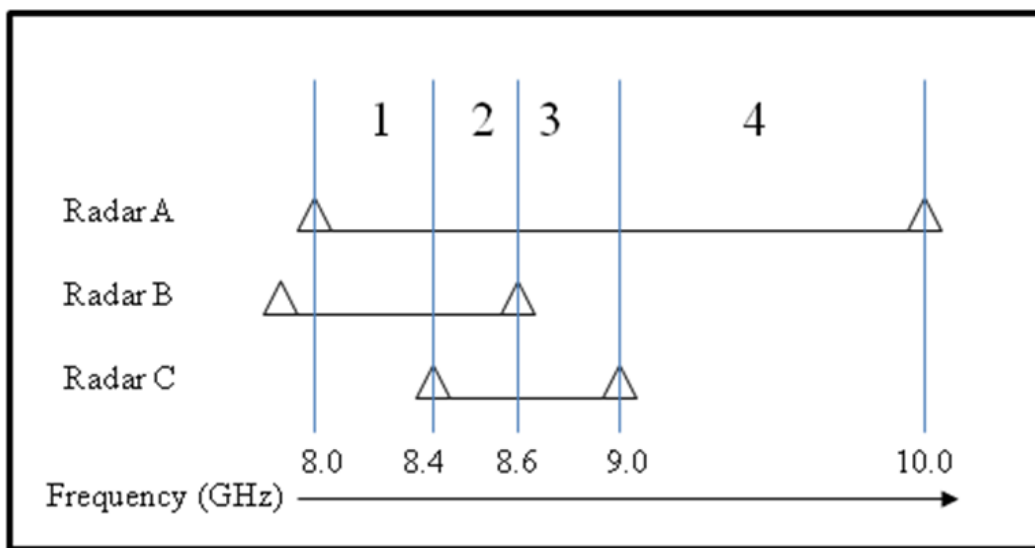

Figure B-1: Notional RWR Dwell Structure.

Therefore, it is likely that when radar A is operating at 8.5 GHz the response time will increase due to the additional processing required to resolve the ambiguity with radar B and the likelihood of a misidentification also increases. If a test team elected to conduct a majority of the testing using radar A operating in frequency region 4, the RWR performance could be radically different than if it occurred in regions 1, 2, or 3. Test designers need to be aware of conditions such as this and consider them when designing test matrices.

## B.5 SELECTED MOPs

### B.5.1 Receiver MOPs

This section addresses receiver MOPs by focusing on their applicability to RWRs, although they may also be applied to other receiver applications.

#### B.5.1.1 Response Time

Response time is one of the most important MOPs. It is a ratio measurement since there is an absolute zero reference. Generically, it is the elapsed time between two events. A federated or integrated EW suite may

## ANNEX B – MEASURES OF PERFORMANCE (MOPs)

have several response times associated with its performance. Figure B-2 shows some of the response times associated with the simple case of a federated EW system with an RWR serving as the EW data bus controller and a mission computer serving as the avionics data bus controller. In this case, the two most important response times are, from a military utility viewpoint, the time between the illumination by a hostile radar and the time that the system warns the aircrew and the time of the CMDS dispense. However, from a T&E and systems engineering standpoint each of the intermediate time intervals are also critical.

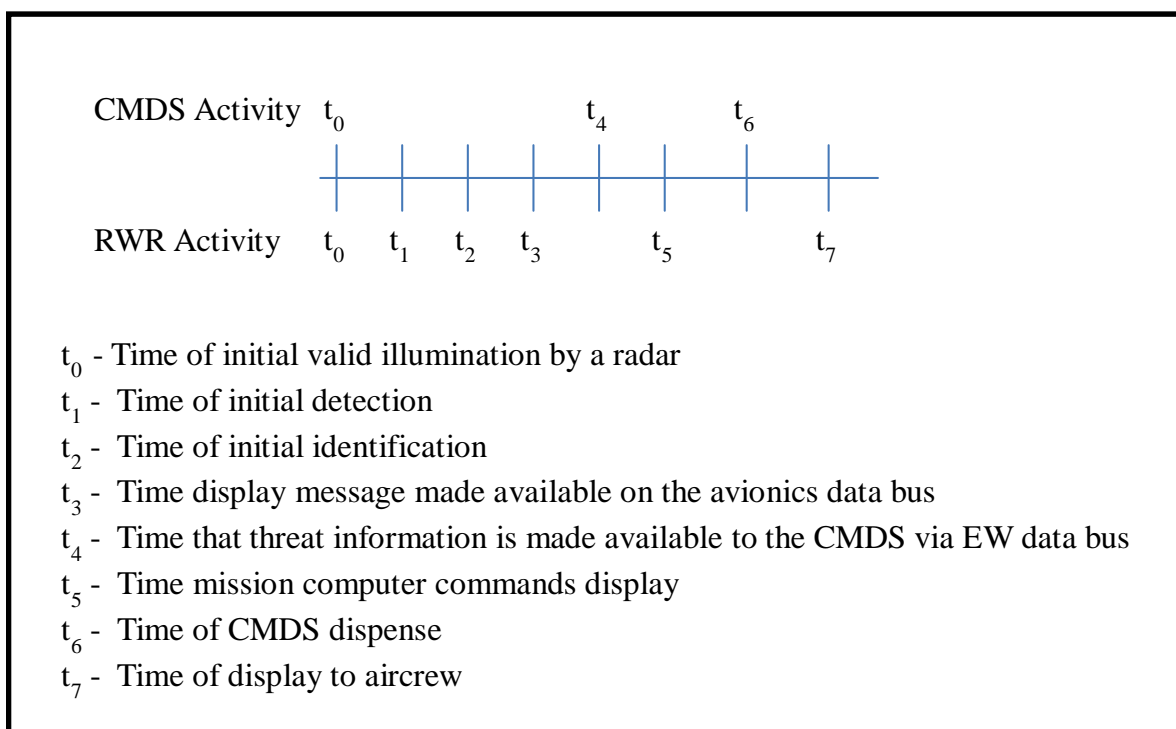

**Figure B-2: Response Times.**

Contractual system specification requirements should clearly identify the system response time budgets that support the overall mission requirements such as the time to display a warning to the aircrew or generate a CMDS dispense. The simple case described above could involve up to three separate contractors: the RWR manufacturer, the CMDS manufacturer, and the airframe integration contractor.

When there is a deficiency in the overall system performance it is important to be able to identify the specific deficiency and who is responsible. The RWR manufacturer only controls the sequence of events leading up to making a display message available on the avionics data bus. The time between the message availability and the mission computer processing it, sending it to the display generator, and generating the display is under the control of the avionics integration contractor. Similarly, the CMDS manufacturer only controls the activity subsequent to receiving data bus messages.

Note that the response time MOP does not necessarily require a correct identification. Although not ideal, if the RWR displays an incorrect symbol and generates an audible warning tone in a timely manner the aircrew still has an opportunity to react. It is better to have an incorrect symbol displayed rapidly than to display the correct symbol when it is too late. If a system incorrectly identifies a threat radar it will be penalized using other MOPs such as percent correct identification.

Response time data, as with other data, can be described by the central tendency and the spread of the data. They are rarely normally distributed and usually skewed to the right. Each individual response time

must be greater than zero, while occasionally, the system will fail to generate a warning and the response time will be effectively infinite.

An average response time value must be treated carefully. First, consider using the mean. When a system fails to generate a warning, a mean cannot be calculated directly. One method of computing a mean when a data sample includes non-response is to transform the data.

Take a simple case with three samples: 2.0 second, 4.0 seconds, and no response. A mean value can be determined by transforming the data by taking the inverse of each value: 0.5, 0.25, and 0.0. The mean of the transformed data is 0.25. Transforming the data again produces a mean value of 4.0 seconds. Non-responses do not pose a problem for computing the median. In any case the test team must agree on the data analysis methods.

The skewed distribution poses a problem for evaluating the spread of the data. For this reason, RWR response time specifications are commonly expressed as percentiles, for example: 90% of the responses shall be less than X seconds. This method has the advantage of being easy to compute and gives some insight into both the central tendency and the spread of the data. Figure B-3 shows a hypothetical data set for a threat system with an acquisition radar, a target tracking radar, and a missile guidance radar; each with its own specification requirement. The box and whiskers plot is an effective way of presenting the data. In Figure B-3, if the response time specifications are 90% less than X seconds, then the RWR meets specifications for the missile guidance and acquisition radars, but does not meet specification for the target tracking radar.

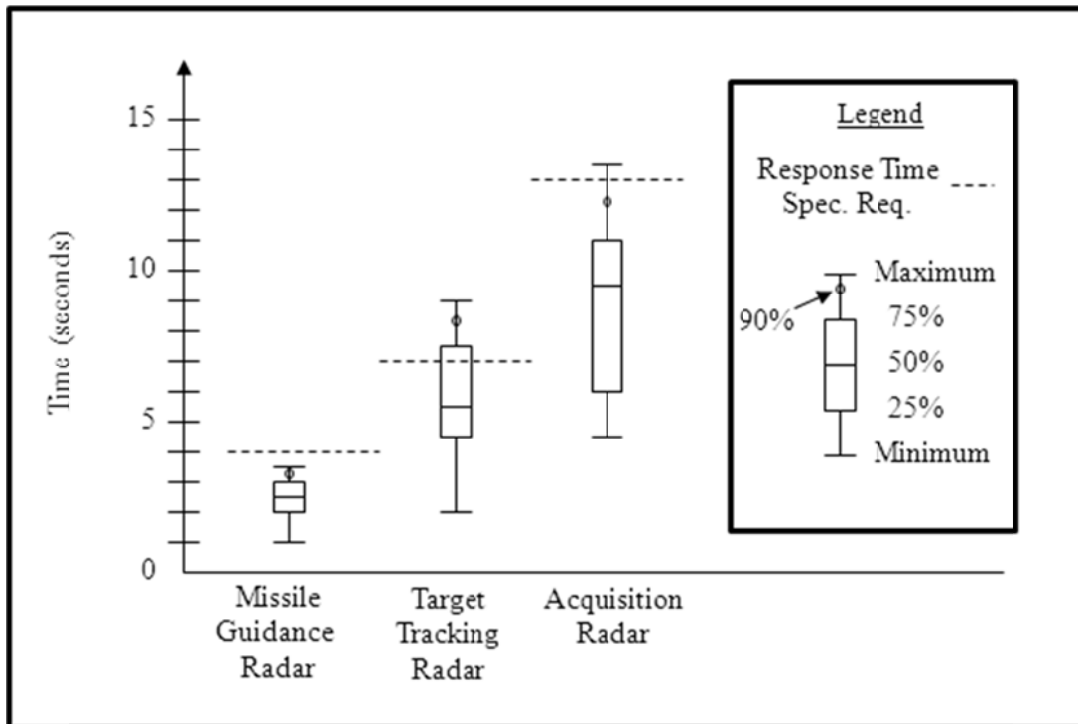

Figure B-3: Percentile Specification for a Hypothetical RWR (Not Real Data).

**B.5.1.2 Correct Initial Identification Percentage**

Radar directed threat systems are often composed of multiple beams. Each time an RWR is presented with a radar beam the system has an opportunity to correctly identify the beam. The correct identification

## **ANNEX B – MEASURES OF PERFORMANCE (MOPS)**

---

percentage is simply the ratio of the number of correct identifications to the number of identification opportunities multiplied by 100.

### **B.5.1.3 Correct Beam Correlation Percentage**

When multiple beams are present the RWR should internally identify each beam individually and correlate them such that only a single symbol associated with the most lethal operating condition of the threat radar is displayed. Anytime more than one beam is present the system has an opportunity to correctly correlate them or to not correlate them if they are from different radar systems. The correct correlation percentage is simply the ratio of the number of correct beam correlations to the number of correlation opportunities multiplied by 100.

### **B.5.1.4 Correct Mode Change Percentage**

Some radars, such as airborne fire control radars, only have a single beam with which to perform multiple functions. A common engagement sequence of events would be for the radar to transition from a search mode, to target tracking mode, and ultimately to a missile launch mode. An RWR should detect each mode change by the radar and update its track files. Every time that a radar transitions modes there is an opportunity for the RWR to correctly detect and process the change. The correct mode change percentage is simply the ratio of the number of correct mode changes to the number of mode change opportunities multiplied by 100. Each mode transition also presents opportunities to collect response time and identification data.

### **B.5.1.5 Maximum Detection Range**

Receivers are typically required to detect specific signals at a specified maximum detection ranges. The measure can be accomplished in flight but it is time consuming to collect enough data to support a statistically meaningful assessment. This is particularly true in the case when a scanning receiver is attempting to detect a scanning radar. Hence, maximum detection range is a measure best evaluated analytically. In reality, the maximum detection range will be described by a statistical distribution. The power density associated with a given signal at the maximum detection range can easily be calculated and compared with the installed sensitivity to determine if the signal will be detected at that range. The installed sensitivity of a receiver is the product of the receiver sensitivity, transmission line losses, amplifier gain (if present in the installation), and the antenna gain and can be easily calculated. The receiver sensitivity and amplifier gain can be measured in a laboratory, the RF transmission line losses can be measured on the aircraft, and the antenna gain patterns can be obtained.

### **B.5.1.6 Angle Of Arrival (AOA) Measurement Accuracy**

EW receiver systems have widely varying AOA accuracy requirements and depend on the purpose of the system, although most specify angular fields of regard. RWRs typically specify a 360 degree azimuth field of regard and are bounded by elevation bands.

The AOA accuracy is determined by analyzing the AOA measurement errors, where AOA error is defined as the difference between the AOA calculated by the system and the true AOA. The error data are often presented by angular bins; commonly as a Root-Mean-Squared (RMS) error versus angular bins.

AOA data can be complicated to analyze. If each measurement is an independent sample the analysis is relatively straightforward. However, most EW systems don't present raw AOA measurements; they typically filter or smooth the data before it is presented or applied. When AOA data are filtered or smoothed, they are no longer independent and care must be taken when performing statistical analyses. Professional statisticians should be consulted when dealing with non-independent data.

### B.5.1.7 Geolocation Accuracy

Some EW systems need to determine the location of ground-based emitters. These systems commonly measure the AOA to the emitter and based on successive measurements and triangulation algorithms produce an error ellipse that should contain the emitter's location as shown in Figure B-4. The speed with which a system can accurately locate an emitter is a function of geometry; it takes longer to locate an emitter off the nose of the aircraft than one off the beam due to the less rapid change in absolute bearing to the emitter.

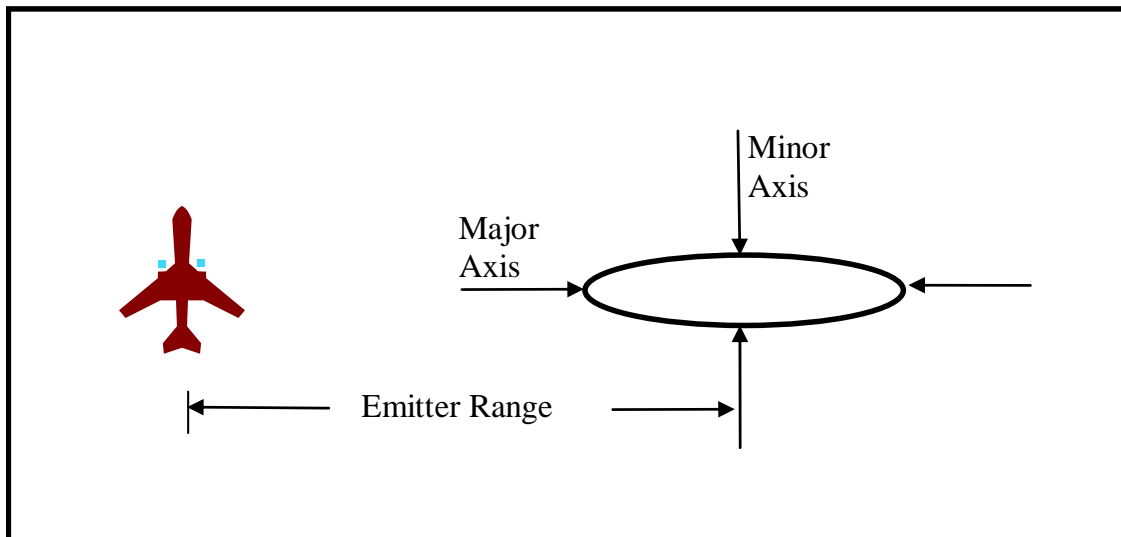

Figure B-4: Geolocation Error Ellipse.

Geolocation systems typically work in one of two ways. The first method is to track the calculated major and minor axes of the error ellipse until they collapse to a specified percentage of the estimated emitter range and when this occurs the system assigns the emitter a location at the centre of the error ellipse. The second method works the same way as the first method, but it does not stop computing the error ellipse and continues to update the computed position as long as the emitter is transmitting. The relevant difference from an analysis standpoint is that if the system determines a single location of an emitter, each location produces a discrete location error. While, if the system continuously computes emitter location the data will consist of a time-based series of emitter location errors.

One means of evaluating the performance of a system that continuously computes emitter location is a version of response time. The performance of the system is evaluated by determining the time for the major ellipse axis to collapse to a specified percentage of the range to the emitter; the time is a function of the geometry. Since there are many considerations consultation with a professional statistician is recommended.

### B.5.2 Jammer MOPs

The ultimate measure of a jammer's utility is whether or not it can protect the aircraft it is designed to protect. This is exceedingly difficult to quantify, particularly in a flight test environment. Aircraft survivability presents a complex evaluation with many combinations and permutations, where jammer effectiveness is only one variable. Each engagement is unique and is a function of the specific conditions of the engagement. Other considerations include manoeuvres, tactics, and other countermeasures such as support jamming or chaff.

Some measures are relatively easy to quantify. Guided weapons or weapons direction systems must maintain an angular track on a target. Radar directed weapons also track targets in range and/or velocity. A means of evaluating the performance of a countermeasures system is to record the tracking error data associated with a target under non-jamming conditions, a condition known as dry and comparing them to the tracking error data collected under the same conditions with the countermeasures system operating, a condition known as wet. Another measure is to evaluate whether or not the jammer selected the correct technique.

While wet-to-dry track error comparisons are useful MOPs for analyzing EA technique effectiveness, they need to be used with caution, as different weapon systems have varying degrees of tolerance to track errors. Some systems can incur very large tracking errors and still successfully complete an engagement. Other MOPs that attempt to address more operationally relevant aspects of a jammer's performance are: cumulative missile miss distance comparisons, reduction in shot opportunities, and Reduction in Lethality (RiL). Each of these has strengths and weaknesses as well.

Simulated missile or projectile fly outs underlie a number of jammer MOPs. These simulations can be purely digitally modelled or use some combination of flight test generated radar data and modelled missile or projectile fly outs. EW data analysts need to fully understand the limitations of the models they use. One of the main EP features of modern radar systems is a well-trained operator in the loop. Understanding how the operator is represented in the model is vital to understanding its utility.

Historically, one of the major problems with using flight test data to support missile fly out modelling has been the inability to precisely and accurately know the location of the target aircraft. While OAR reference radars are good enough for many purposes, their accuracy imposed significant limitations on missile fly out simulations that attempted to determine hits or misses. The TSPI location errors for the test aircraft were often on the order of the warhead lethal radius, particularly for smaller missiles. This problem has been somewhat alleviated by the use of very accurate Global Positioning System (GPS) data as a Time-Space-Position Information (TSPI) source. Testers should remain aware of the importance of precise and accurate target TSPI data.

No single MOP comprehensively addresses the performance of an EA system; however, every good MOP indicates something about the performance of an EA system. A prudent analyst will examine as many MOPs as practical to evaluate the system performance.

### **B.5.2.1 Tracking Errors**

Dry versus wet tracking errors are commonly presented in a range versus tracking error format; with the range separated into bins. Median errors are most commonly presented. Data are presented by threat system and test conditions and normally consist of a compilation of several individual passes. Figure B-5 shows an example of median range tracking error plot. Median is more commonly used than mean as an average since a small number of very large errors can cause misleadingly large errors if the mean is used.



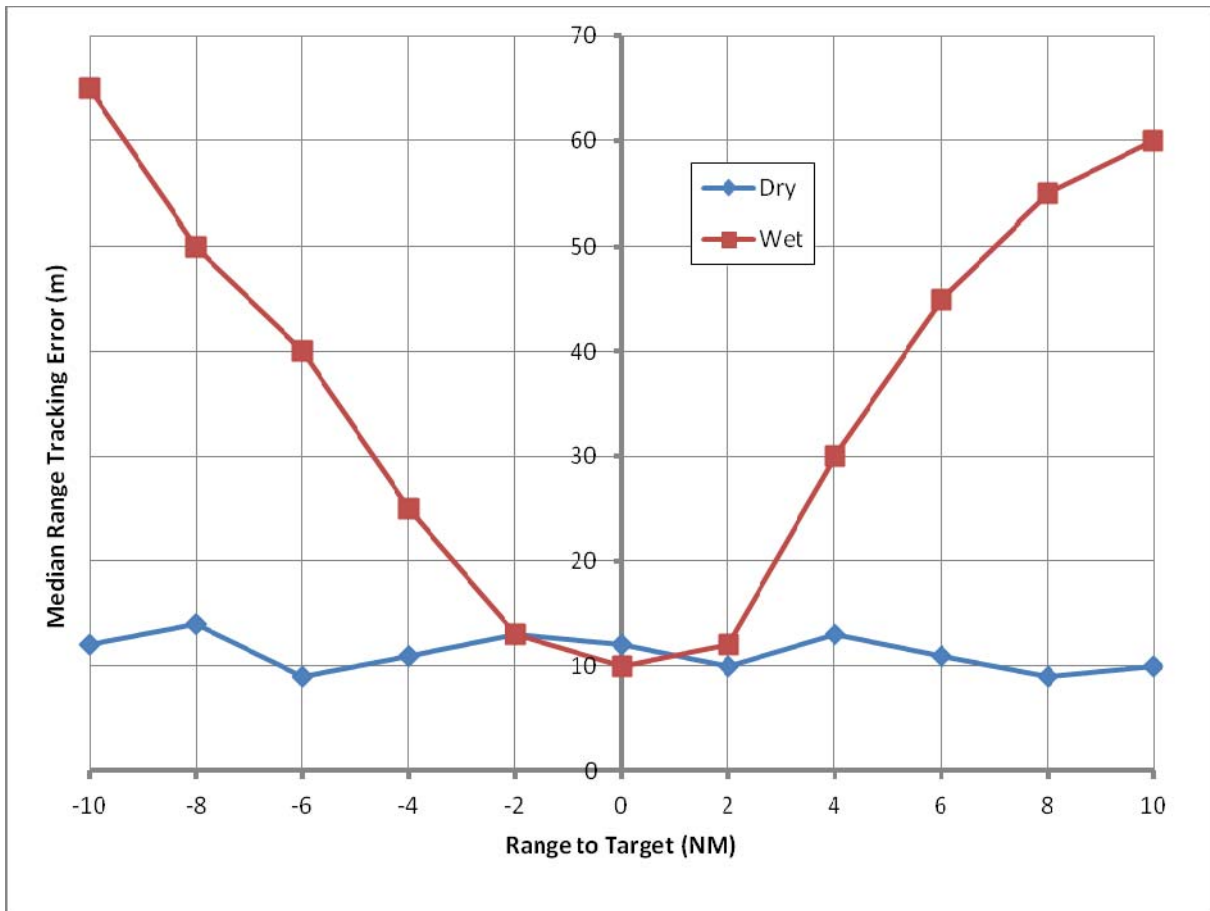

Figure B-5: Sample Median Range Tracking Error Plot (For a Given Threat Radar and Test Condition).

**B.5.2.2 Cumulative Missile Miss Distances**

Cumulative missile miss distance plots present the results of simulated missile fly outs as a comparison of dry versus wet results. Figure B-6 shows a sample graph. The graph indicates that jamming has increased the missile miss distance. Ninety percent of the dry run miss distances were within 10 meters while only 10 percent of the wet run miss distances were within 10 meters. The data should be collected to the maximum extent possible under the same conditions for both dry and wet runs.

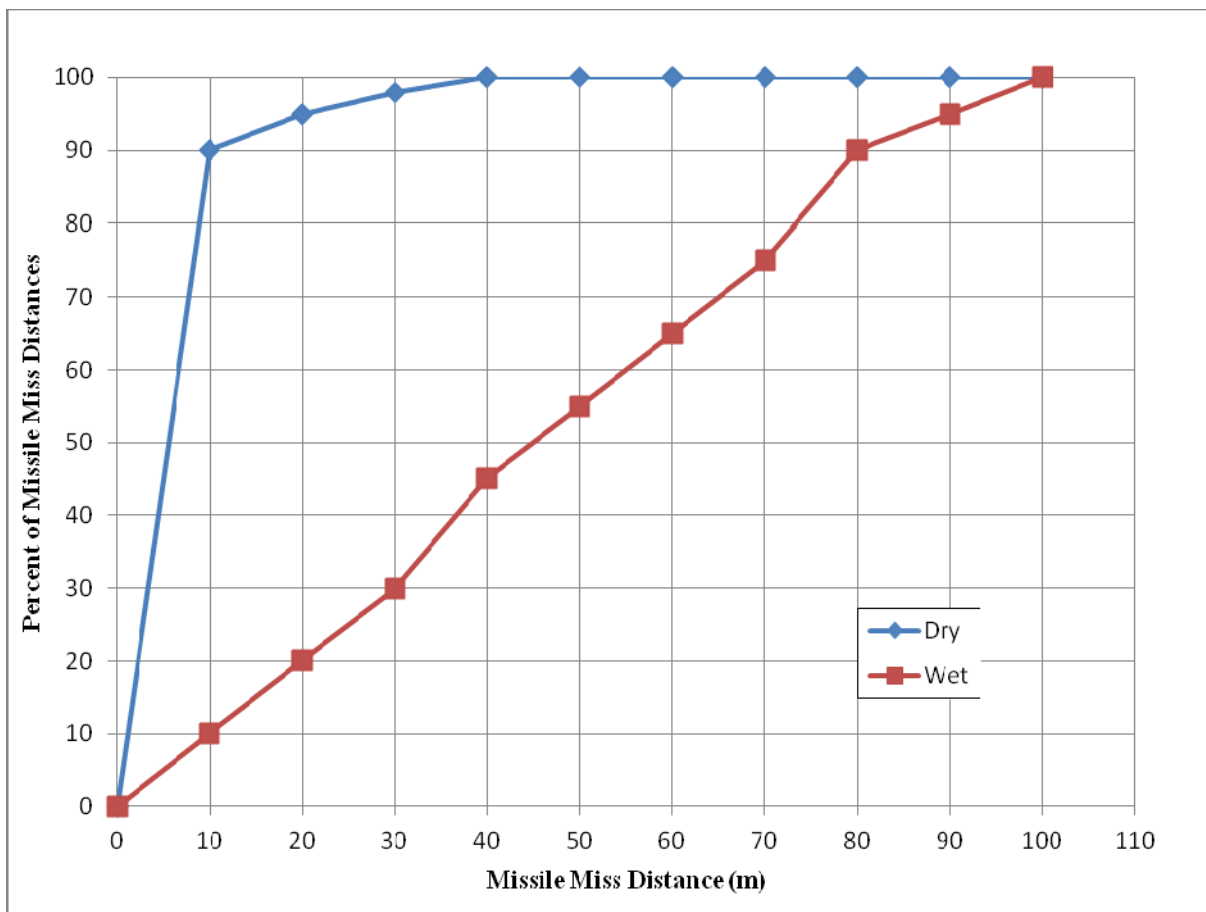

Figure B-6: Example of a Missile Miss Distance Cumulative Percentage Plot.

### B.5.2.3 Reduction in Shot Opportunities

One of the benefits of effective self protection jamming is that the EA technique will disrupt the threat system and deny the threat system operators shot opportunities. Reduction in Shot Opportunities (RiS) can be expressed as:

$$RiS = \left[ 1 - \frac{\frac{\text{Number of Shots (Wet)}}{\text{Number of Passes (Wet)}}}{\frac{\text{Number of Shots (Dry)}}{\text{Number of Passes (Dry)}}} \right] \times 100$$

### B.5.2.4 Reduction in Lethality

Reduction in Lethality (RiL) is a measure that attempts to quantify the effectiveness of the jammer. It is defined as follows:

$$RiL = \left[ 1 - \frac{\frac{\text{Number of Hits (Wet)}}{\text{Number of Passes (Wet)}}}{\frac{\text{Number of Hits (Dry)}}{\text{Number of Passes (Dry)}}} \right] \times 100$$

RiL has two main advantages: it is easy to compute and it focuses on whether or not the threat system successfully engaged the protected aircraft. However, it has a number of disadvantages. The primary

shortfall comes from determining the definition of a “hit”. Hits are commonly determined by comparing the calculated or simulated missile miss distance to a predetermined miss distance from the aircraft. This distance is often based on the largest dimension of the aircraft (for example, half of the wing span) plus some fixed number representing the lethal radius of the warhead. This considerably oversimplifies the warhead-target interaction, particularly for missiles with small warheads. Another shortfall is that the term RiL is a misnomer; the expression defined above might more properly be termed a Reduction in Susceptibility, since it address hits and misses instead of kills or lethality. Additionally, when RiL is based on flight test data the previously discussed problem of target location accuracy and precision must be considered.

## **B.6 REFERENCES**

- [1] Defense Acquisition University, “Glossary of Defense Acquisition Acronyms and Terms”, 12<sup>th</sup> edition, Defense Acquisition University Press, Fort Belvoir, Virginia 22060-5565, July 2005, p. B-40.
- [2] DAU, p. B-103.
- [3] DAU, p. B-103.
- [4] DAU, p. B-103.
- [5] Stevens, S.S., “On the Theory of Scales of Measurement”, Science, Vol. 103, No. 2684, 7 June 1946, p. 677.
- [6] Stevens, pp. 678-679.

## **B.7 FURTHER READING**

Huber, A.F., Timmerman, T.J. and Gibbons, J., “Testing and Evaluating the Military Worth of Electronic Warfare Systems”, Society of Flight Test Engineers, 28<sup>th</sup> Annual Symposium Proceedings, August 1997.

Sproles, N., “Avoiding Confusion – A Case for Establishing Standards for Measures of Effectiveness”, ITEA Journal, September/October 1998, pp. 26-30.

Sproles, N., “Coming to Grips with Measures of Effectiveness”, Systems Engineering, 1998, pp. 1-8.

## ANNEX B – MEASURES OF PERFORMANCE (MOPs)

---



## Annex C – JAMMING-TO-SIGNAL RATIO

### C.1 INTRODUCTION

J/S is one of the most important measures in EA technique design and performance analysis. It is defined as the ratio of the jamming signal strength  $J$  within the victim receiver's bandwidth to the desired signal strength  $S$ . To be effective, a jamming technique must insert sufficient jamming energy into the receiver's pass band to produce a desired effect on the victim system. There are a number of different applications and EA techniques and the required J/S varies widely. Some techniques may be effective with less than 0 dB (1:1) while others may require 30 dB (1000:1) or more.

This annex shows the development of the J/S expression for two of the most common forms: defensive EA (SPJ) against a ground-based radar and offensive EA (SOJ) against a ground-based radar. Other cases such as defensive EA against a semi-active missile and communication jamming can be developed in a similar manner and are left to the reader.

### C.2 J/S FOR DEFENSIVE EA AGAINST A GROUND-BASED RADAR

Figure C-1 illustrates the defensive EA case. A ground-based radar is tracking a target aircraft carrying a defensive EA system and the defensive EA system is jamming it. The main beam of the EA system is pointing toward the victim radar.

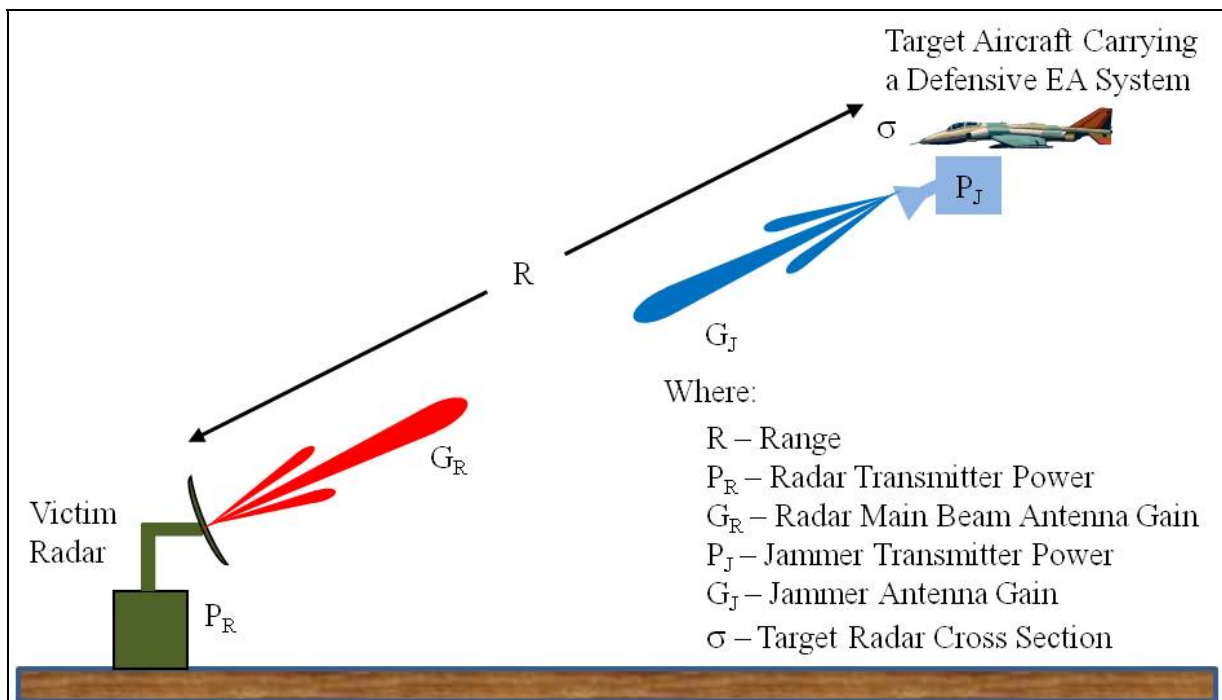

**Figure C-1: J/S for Defensive EA Against a Ground-Based Radar.**

The first step is to determine the signal power  $S$  returned from the target at the victim radar receiver.

If the power generated by the radar transmitter  $P_R$  is distributed isotropically (uniformly in all directions as over the surface area of a sphere) the power density, in Watts per unit area, at a given range  $R$  can be determined by the equation:

$$\text{Power density from an isotropic antenna} = \frac{P_R}{4\pi R^2} \quad (C1)$$

Radars, however, employ directive antennas to focus the transmitted energy in a desired direction, thereby multiplying the isotropic power density by the gain  $G_R$  of the radar antenna; therefore:

$$\text{Power density from an directive antenna} = \frac{P_R G_R}{4\pi R^2} \quad (C2)$$

A certain portion of that energy intercepting the target at range  $R$  is backscattered toward the radar. The amount of backscattered energy is related to the Radar Cross-Section (RCS)  $\sigma$  of the target. The RCS has units of area and is a function of the electrical properties of the target. The incident energy returning from the target to the radar also incurs a  $1/4\pi R^2$  spreading loss. Therefore:

$$\text{Power density of the returning signal at the radar} = \frac{P_R G_R}{4\pi R^2} \frac{\sigma}{4\pi R^2} \quad (C3)$$

The radar antenna will capture a portion of returning signal. The amount of energy captured by the antenna is determined by its effective aperture  $A_e$ . The effective aperture, as with the RCS, has units of area and is also a function of the electrical properties of the antenna. The desired signal power  $S$  returned from the target is:

$$S = \frac{P_R G_R}{4\pi R^2} \frac{\sigma}{4\pi R^2} A_e = \left[ \frac{P_R G_R \sigma A_e}{(4\pi)^2 R^4} \right] \quad (C4)$$

The relevant characteristic of this expression in the J/S discussion is that the desired signal power  $S$  at the radar varies as a function of  $R^{-4}$ .

The jammer power  $J$  at the victim radar can be derived in a similar manner using the jammer's transmitter power  $P_J$  and the jammer's antenna gain  $G_J$ . The power density transmitted by the jammer is:

$$\text{Power density from a directive jammer antenna} = \frac{P_J G_J}{4\pi R^2} \quad (C5)$$

The jammer energy entering the radar antenna will encounter the same effective aperture as the radar signal. Therefore, the jamming power produced at the radar antenna output is:

$$J = \frac{P_J G_J}{4\pi R^2} A_e \quad (C6)$$

Note that, unlike the expression for the desired radar signal  $S$ , which varies as a function of  $R^{-4}$ , the expression for jammer power at the victim radar varies as a function of  $R^{-2}$ . This is because the radar signal is a two-way path while the jammer transmission is only a one-way path.

J/S can then be described as:

$$J/S = \frac{P_R G_R 4\pi}{P_J G_J \sigma} R^2 \quad (C7)$$

The  $R^2$  term dominates the equation and the somewhat counterintuitive effect is that J/S decreases exponentially as the jammer gets closer to the radar it is jamming. The extreme result is that when the range approaches zero, J/S also approaches zero.



Figure C-2 illustrates an example of how the jamming and signal powers vary as functions of range. Note that both signals are increasing in power as the range to the target decreases, but the target return signal is increasing at a faster rate, eventually equalling it and overtaking it. [1]

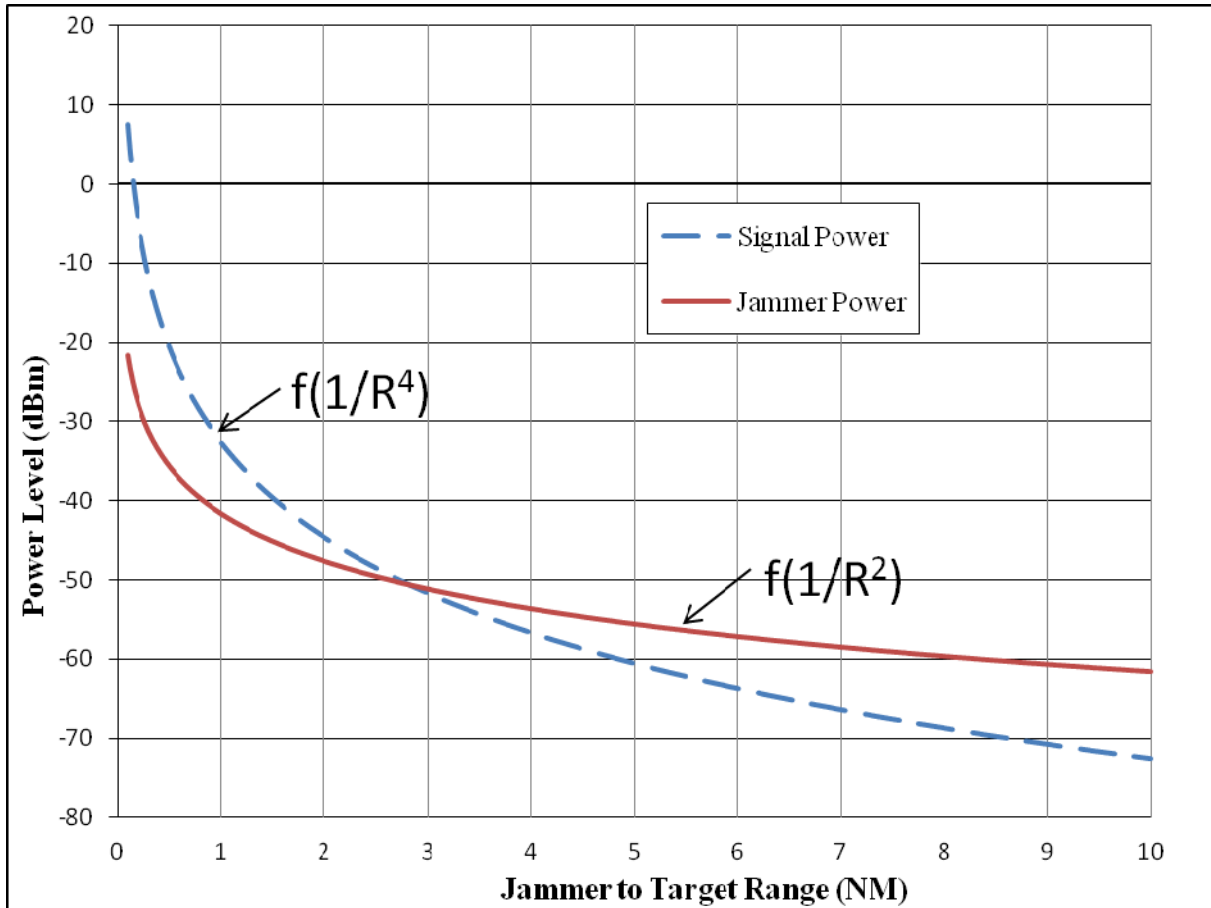

Figure C-2: Jamming and Target Return Signal Power Variation.

Figure C-3 shows the same data presented in terms of J/S. A hypothetical EA technique requires a minimum J/S of 4:1 (6 dB) to be effective. The J/S falls below 4 at approximately 5.7 Nautical Miles (NM). This range is often called the burnthrough range, i.e. the range at which the EA system no longer has enough of a power margin over the target signal return to be effective. In practice it is difficult to identify a specific burnthrough range as factors such as radar operator skill and target RCS variation can affect the ability of the radar system to engage a target.

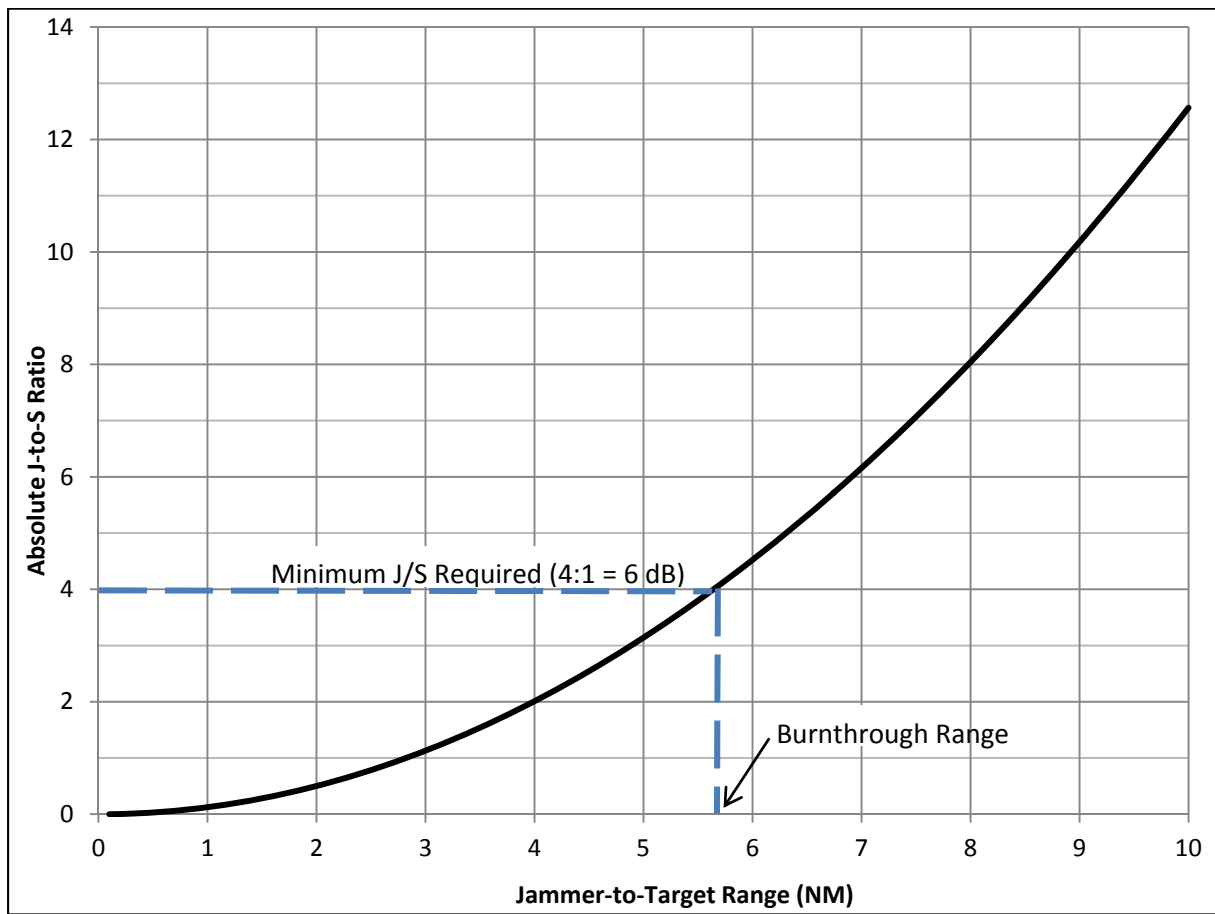

Figure C-3: J/S and Burnthrough Range.

### C.3 J/S FOR OFFENSIVE EA AGAINST A GROUND-BASED RADAR

The J/S computation is different for the offensive EA case. The geometry is illustrated in Figure C-4. The stand-off jamming is performed by a support EA aircraft with the intent of protecting other aircraft. The radar signal return power S is calculated the same way as in the defensive EA case; however, the J calculation will be different since the aircraft carrying the jammer may be offset in angle from the protected aircraft and will be operating at a different range ( $R_j$ ).

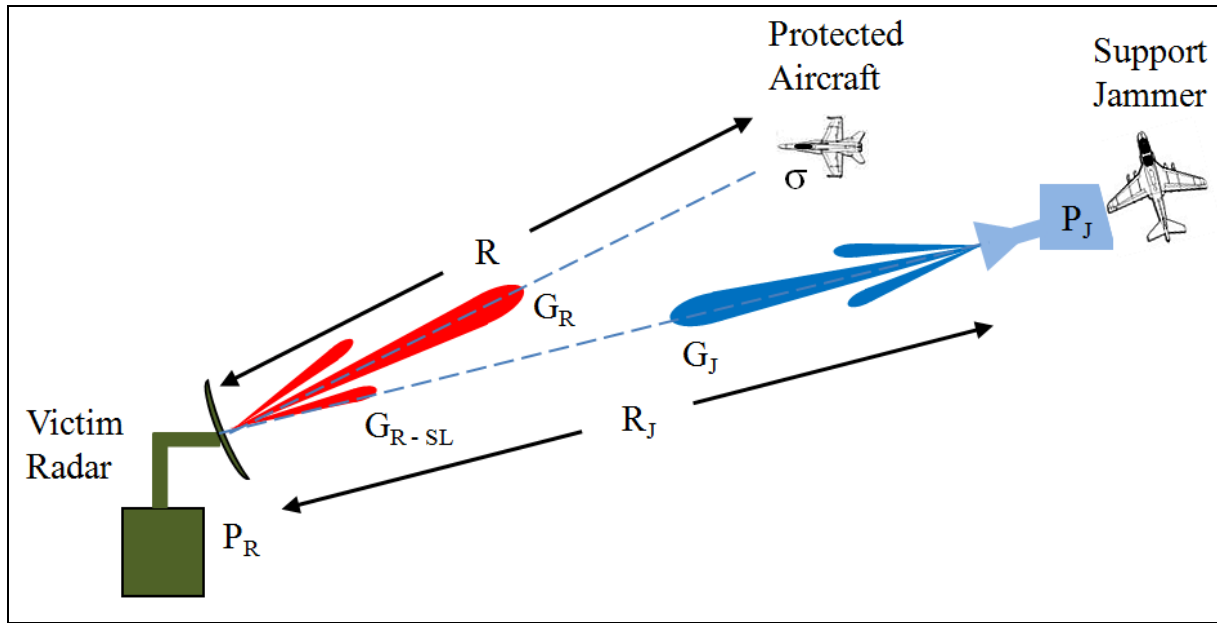

Figure C-4: J/S for Offensive EA Against a Ground-Based Radar.

Offensive EA is frequently directed against azimuth-scanning surveillance radars. Often the support jamming aircraft will be operating at a different azimuth than the protected aircraft. This means that when the protected aircraft is in the main beam of the surveillance radar, the jamming energy from the support jammer is entering the radar through a sidelobe with a different gain  $G_{R-SL}$  than the radar antenna main lobe  $G_R$ . This also means that unlike in the defensive EA scenario shown in Figure C-4, the effective aperture will be different ( $A_e'$ ). In practice, as the antenna rotates, the jammer will jam over the entire radar antenna pattern.

For the scenario shown, jammer power density at the victim radar is:

$$J = \frac{P_J G_J}{4\pi R_J^2} A_e' \tag{C8}$$

The resultant expression for J/S is:

$$J/S = \frac{P_J G_J R^4}{P_R G_R R_J^2} \frac{4\pi}{\sigma} \frac{A_e'}{A_e} \tag{C9}$$

### C.4 REFERENCES

[1] Stimson, G.W., “Introduction to Airborne Radar”, Raleigh, NC, SciTech Publishing Inc., 1998, (ISBN 1-891121-01-4).

### C.5 FURTHER READING

Adamy, D.L., EW 101: “A First Course in Electronic Warfare”, Norwood, MA, Artech House, Inc., 2001, (ISBN 1-58053-169-5). Chapter 9, Jamming.

Chrzanowski, E.J., “Active Radar Electronic Countermeasures”, Norwood, MA, Artech House, Inc., 1990, (ISBN 0-89006-290-0).

## **ANNEX C – JAMMING-TO-SIGNAL RATIO**

---

Van Brunt, L.B., “Applied ECM”, Dunn Loring, VA, EW Engineering, Inc., Vol. 1 (1978, ISBN 0-931728-00-2); Vol. 2 (1982, ISBN 0-931728-01-0); Vol. 3 (1995, ISBN 0-931728-03-7).

Weigand, R.J., “Radar Electronic Countermeasures System Design”, Artech House, Norwood, MA, 1991, ISBN 0-89006-381-8.

## Annex D – GLOSSARY

**Airborne Testbeds** – Ranging from small aircraft with pod-mounted components or systems to large aircraft designed for spread-bench installation and testing of EW and avionic systems. They permit the flight testing of EW components, sub-systems, systems, or functions of avionic suites in early development and modification, often before the availability of prototype or production hardware.

**Amplitude Modulation (AM)** – Modulation of the amplitude of a radio carrier wave in accordance with the strength of the audio or other signal. A radar angle tracking method using the time varying amplitude of the returning target signal to generate an error signal to correct the boresight position of the antenna.

**Angle Of Arrival (AOA)** – The direction of arrival of a signal normally referenced to the aircraft body coordinate system.

**Antenna Gain** – The dimensionless ratio of the intensity of an antenna in a given direction to the intensity that would be produced by a hypothetical ideal antenna that radiates equally in all directions (isotropically) and has no losses.

**Anti-Radiation Missile (ARM)** – An air-to-surface missile with an RF seeker designed to track and home on threat radar transmission.

**Aperture** – An EM opening through which energy can pass.

**Beamwidth (half-power)** – In a plane containing the direction of the maximum of a beam, the angle between the two directions in which the radiation intensity is one-half the maximum intensity of the beam.

**Blanker** – A device that manages RF suppression management in a platform. Also called a Central Suppression Unit.

**Burn-through Range** – The range at which a jamming technique is no longer effective. The point where the target skin return energy exceeds the jamming energy by a sufficiently large margin to negate the EA technique's effectiveness.

**Chaff** – A form of EA in which aircraft or other targets spread a cloud of small, thin pieces of aluminium, metallised glass fibre or plastic, which either appears as a cluster of secondary targets on radar screens or swamps the screen with multiple returns.

**Closed-Loop** – A system in which the output has an effect on the input quality in such a manner as to maintain the desired output.

**Communications Intelligence (COMINT)** – Technical information and intelligence derived from foreign communications by other than the intended recipients.

**Continuous Wave (CW)** – An EM transmission that is continuously operating, as opposed to pulsed operation.

**Countermeasures** – That form of military science that, by the employment of devices and/or techniques, has as its objective the impairment of the operational effectiveness of enemy activity.

**Countermeasures Dispensing System (CMDS)** – A system that dispenses expendable countermeasures, such as chaff and flares.

## ANNEX D – GLOSSARY

---

**Data Analysis Plan (DAP)** – A document that details how the collected test data will be reduced, processed, analysed, and used to calculate the MOPs.

**Data Reduction** – The process of converting recorded data to engineering units and the data analysis process to produce a data set that can be evaluated.

**Deceptive Jamming** – An EA technique focused on deceiving an operator or the automatic detection and processing functions of a radar; also called false target jamming.

**Digital RF Memory (DRFM)** – Technology employed in RF countermeasures systems. DRFM-based techniques allow a jammer to produce very high quality false targets. They do this by sampling the incoming pulses and storing them. The stored pulses retain the nuances of the received pulses, such as phase coherency or intrapulse modulation. These stored pulses can then be modulated and retransmitted back toward the victim radar.

**Directed Energy (DE)** – An umbrella term covering technologies that produce a beam of concentrated EM energy or atomic or sub-atomic particles. A DE weapon is a system using DE primarily as a direct means to damage or destroy adversary equipment, facilities, and personnel. DE warfare is military action involving the use of DE weapons, devices, and countermeasures to either cause direct damage or destruction of adversary equipment, facilities, and personnel, or to determine, exploit, reduce, or prevent hostile use of the EM spectrum through damage, destruction, and disruption.

**Dry** – A test condition where the EA system is not operating, i.e., in standby mode or off.

**Developmental Test & Evaluation (DT&E)** – 1. Any testing used to assist in the development and maturation of products, product elements, or manufacturing or support processes. 2. Any engineering-type test used to verify status of technical progress, verify that design risks are minimised, substantiate achievement of contract technical performance, and certify readiness for initial Operational Testing (OT). Development tests generally require instrumentation and measurements and are accomplished by engineers, technicians, or soldier operator-maintainer test personnel in a controlled environment to facilitate failure analysis.

**Dynamic Range** – The input signal amplitude range that the receiver can process properly. The lower limit is the receiver sensitivity (MDS is commonly used). There is no universally accepted definition for the lower or the upper limit of the input signal level.

**Effective Radiated Power (ERP)** – The power transmitted by a system; the product of the transmitter power, transmission line losses, and antenna gain.

**Effectiveness** – The extent to which the goals of the system are attained, or the degree to which a system can be elected to achieve a set of specific mission requirements. Also, an output of a cost-effectiveness analysis.

**Electromagnetic Wave** – One of the waves that are propagated by simultaneous periodic variations of the electric and magnetic field intensity and that include radio waves, infrared, visible light, ultraviolet, X rays, and gamma radiation.

**Electromagnetic Compatibility (EMC)** – The ability of systems, equipment, and devices that utilise the EM spectrum to operate in their intended operational environments without suffering unacceptable degradation or causing unintentional degradation because of EM radiation or response. It involves the application of sound EM spectrum management; system, equipment, and device design configuration that ensures interference-free operation; and clear concepts and doctrines that maximise operational effectiveness.



**Electromagnetic Hardening** – Action taken to protect personnel, facilities, and/or equipment by filtering, attenuating, grounding, bonding, and/or shielding against undesirable effects of EM energy.

**Electromagnetic Interference (EMI)** – Any EM disturbance that interrupts, obstructs, or otherwise degrades or limits the effective performance of electronics and electrical equipment. It can be induced intentionally, as in some forms of electronic warfare, or unintentionally, as a result of spurious emissions and responses, intermodulation products, and the like.

**Electromagnetic Pulse (EMP)** – The EM radiation from a strong electronic pulse, most commonly caused by a nuclear explosion that may couple with electrical or electronic systems to produce damaging current and voltage surges.

**Electromagnetic Spectrum** – The range of frequencies of EM radiation from zero to infinity. It is divided into 26 alphabetically designated bands.

**Electronic Attack (EA)** – The use of EM energy, Directed Energy (DE), or anti-radiation weapons to attack personnel, facilities, or equipment with the intent of degrading, neutralising or destroying enemy combat capability and is considered a form of fires.

**Electronic Protection (EP)** – Actions taken to protect personnel, facilities, and equipment from any effects of friendly or enemy use of EM spectrum that degrade, neutralise, or destroy friendly combat capability.

**Electronic Warfare (EW)** – The use of EM or directed energy (DE) to control the EM spectrum or to attack the enemy.

**Electronic Warfare Support (ES)** – Actions taken by, or under direct control, of an operational commander to search for, intercept, identify and locate, or localise sources of intentional and unintentional radiated EM energy for the purpose of immediate threat recognition, targeting, planning, and conduct of future operations.

**Electro-Optical (EO)** – Of or relating to a branch of technology involving components, devices and systems which operate by modification of the optical properties of a material by an electric field.

**Electronic Intelligence (ELINT)** – Technical and geolocation intelligence derived from foreign non-communications EM radiations emanating from other than nuclear detonations or radioactive sources.

**Emission Control (EMCON)** – The selective and controlled use of EM, acoustic, or other emitters to optimise command and control capabilities while minimising, for operations security: a. detection, by enemy sensors; b. mutual interference among friendly systems; and/or c. enemy interference with the ability to execute a military deception plan.

**Escort Jamming** – A form of support jamming where the jamming aircraft flies along with the aircraft it is protecting.

**False Alarm** – A warning generated when no threat is present.

**False Alarm Rate** – The rate at which false alarms occur, normally expressed in false alarms per hour.

**Flares** – Expendable pyrotechnic defensive EA devices designed to capture the seeker of an IR-guided missile and seduce it away from the targeted aircraft.

**Frequency Selectivity** – A measure of the ability of a receiver to distinguish between two signals of different frequencies.

**Geolocation** – The process of determining the position of a ground-based emitter.

**Hardware In The Loop (HITL)** – Indoor test facilities that provide a secure environment to test EW techniques and hardware against simulators of threat systems. Primary EW HITL facilities contain simulations of hostile weapon system hardware or the actual hostile weapon system hardware. They are used to determine threat system susceptibility and to evaluate the performance of EW systems and techniques.

**High-Energy Laser (HEL) Weapon** – A system that directs light energy at targets using the properties of coherent EM radiation. HEL systems are often categorised by the method of excitation, cooling, or the gain material. Some HELs are gas-dynamic lasers. These lasers are pumped by combustion or an energetic chemical reaction. Some lasers have a liquid gain medium or are liquid-cooled. SSLs have a crystalline or glass gain medium. SSLs have recently become viable contenders for HEL applications. All lasers can be formed into a tight beam because of the property of coherence, meaning that the phase relationship is preserved to the point that interference of the waves can occur.

**High-Power Microwave (HPM)** – HPM weapons are systems that emit RF energy at high peak power levels and are often categorised by the bandwidth-to-frequency ratio of their waveforms. These are typically very large ratios. They have been divided into narrowband, wideband, and ultra wideband. HPM devices have a smaller effective range than the EMP effects of a nuclear weapon. Narrowband devices tend to operate on specific electronic vulnerabilities in the target and therefore, require knowledge of enemy systems to be effective. Ultra-wideband devices tend to be simpler and cheaper, using powerful transient waveforms, and requiring less knowledge of the target. A few HPM weapons function by making use of psycho-sensory or neural phenomena, rather than just high power levels, to deter human actions or cause confusion among attacking troops.

**Infrared (IR)** – EM radiation with a wavelength between 0.7 and 300 micrometres.

**Infrared Countermeasures (IRCM)** – EA techniques directed against IR-guided weapons.

**Installed Receiver Sensitivity** – A measure of how the receiver transmission line including the antenna and amplifiers (if present) affects the receiver system's MDS. If the transmission line has positive gain, the system sensitivity will increase and if it has negative gain it will decrease.

**Installed System Test Facility (ISTF)** – Facilities that provide a secure capability to evaluate EW systems that are installed on, or integrated with, host platforms. These test facilities consist of anechoic chambers in which free-space radiation measurements are made during the simultaneous operation of EW systems and host platform avionics and munitions.

**Isolation** – The amount of signal loss between a transmitting antenna and a receiving antenna. Sufficient isolation between antennas prevents EMI.

**Intermediate Level (I-Level) Maintenance** – That level of maintenance/repair of items that do not have to go to depot level for major work and are incapable of maintenance/repair at the organizational level.

**Jamming-to-Signal (J/S)** – The ratio of the jamming signal strength J within the victim receiver's bandwidth to the desired signal strength S. To be effective, a jamming technique must insert sufficient jamming energy into the receiver's pass band to produce a desired effect on the victim system.

**Kinematics** – The study of the geometry of motion; relates displacement, velocity, acceleration and time, without reference to the cause of the motion.

**Laser Warning System (LWS)** – An ES system designed to detect the laser energy associated laser range finders or beam riding missiles and warn the aircrew.

**Line Replaceable Unit (LRU)** – An essential support item removed and replaced at field level to restore an end item to an operationally ready condition. (Also called Weapon Replacement Assembly (WRA) and Module Replaceable Unit.)

**Low Observable (LO)** – LO platforms are characterised by reduced signatures, most prevalently in the RCS and IR realms.

**Man Portable Air Defence System (MANPADS)** – Short-range normally infrared guided (heat-seeking) SAMs.

**Measure Of Effectiveness (MOE)** – Measure designed to correspond to accomplishment of mission objectives and achievement of desired results. MOEs may be further decomposed into Measures of Performance and Measures of Suitability.

**Measure Of Performance (MOP)** – Measure of a system's performance expressed as speed, payload, range, time on station, frequency, or other distinctly quantifiable performance features. Several MOPs and/or Measures of Suitability may be related to the achievement of a particular Measure of Effectiveness (MOE).

**Measurement Facilities (MF)** – Facilities that establish the character of an EW related system/sub-system or technology. They provide capabilities to explore and evaluate advanced technologies such as those involved with various sensors and multi-spectral signature reduction.

**Military End User** – The military organisation using the weapons systems in combat.

**Minimum Discernable Signal (MDS)** – The lowest power signal that can be discerned from the noise, i.e., the point where the signal power is equal to the noise power in the receiver.

**Missile Warning System (MWS)** – An ES system that warns aircrew of attacks by passive homing missiles (most commonly IR-guided) by detecting the IR and/or UV signature of a missile rocket motor plume.

**Mission** – The objective or task, together with the purpose, which clearly indicates the action to be taken.

**Mission Data** – The compilation of threat system parametric data, such as frequency ranges, PRI, scan rates, scan types, etc., along with threat system identifications and priority. Mission data sets are normally tailored to meet the requirements for a specific theatre of operations.

**Mission Data File (MDF)** – The file containing the mission data sets that is loaded into an EA or ES system; analogous to computer application.

**Model** – A representation of an actual or conceptual system that involves mathematics, logical expressions, or computer simulations that can be used to predict how the system might perform or survive under various conditions or in a range of hostile environments.

**Modelling and Simulation (M&S)** – Used to represent systems, host platforms, other friendly players, the combat environment, and threat systems. They can be used to help design and define EW systems and

## ANNEX D – GLOSSARY

---

testing with threat simulations and missile fly-out models. Due to the relatively low cost of exercising these models, this type of activity can be run many times to check ‘what ifs’ and explore the widest possible range of system parameters without concern for flight safety. These models may run interactively in real or simulated time and space domains, along with other factors of a combat environment, to support the entire T&E process.

**Noise Jamming** – An EA technique designed to prevent target detection by raising the noise level in a victim receiver to the point that the jamming energy exceeds the target energy.

**Open Air Range (OAR)** – Test facilities used to evaluate EW systems in background, clutter, noise and dynamic environments. Typically these resources are divided into sub-categories of test ranges and airborne testbeds. Open Air Range EW flight test ranges are instrumented and populated with high-fidelity manned or unmanned threat simulators. Additional emitter-only threat simulators are also used to provide the high signal density characterising typical operational EW environments.

**Open-Loop** – A system in which the output has no effect on the input signal.

**Operational Flight Program (OFP)** – The software performing the executive functions of a system; analogous to a computer’s operating system.

**Operational Security (OPSEC)** – Protection of military operations and activities resulting from identification and subsequent elimination or control of indicators susceptible to hostile operations.

**Operational Test & Evaluation (OT&E)** – The field test, under realistic conditions, of any item (or key component) of weapons, equipment, or munitions for the purpose of determining the effectiveness and suitability of the weapons, equipment, or munitions for use in combat by typical military users; and the evaluation of the results of such tests.

**Probability of Kill ( $P_K$ )** – The product of susceptibility and vulnerability.

**Program Introduction Document (PID)** – A document provided by a test customer to a test facility identifying technical and schedule requirements. See Statement of Capability (SOC).

**Pulse Width (PW)** – The duration in time of an EM pulse.

**Pulse Repetition Frequency (PRF)** – The number of pulses per second.

**Pulse Repetition Interval (PRI)** – The time duration between the beginning of successive pulses.

**Pulse-Doppler Radar** – A type of radar that uses a high PRF coherent waveform to detect and track targets in the frequency domain. The technique also permits look-down, shoot-down operations by airborne radars.

**Radar Cross-Section (RCS)** – Is a measure of how detectable a target is by a radar. A larger RCS indicates that an object is more easily detected.

**Radar Warning Receiver (RWR)** – A system that detects, identifies, locates, and determines the relative lethality of radar directed threat systems. It serves to warn aircrew of hostile radar activity and provides cueing information to other countermeasures systems such as chaff dispensers.

**Radio Frequency (RF)** – Is a rate of oscillation in the range of about 30 kHz to 300 GHz, which corresponds to the frequency of electrical signals normally used to produce and detect radio waves.

**Regression Testing** – Testing conducted following a hardware, software, or mission data change to determine if the changes have inadvertently affected other aspects of system performance.

**Role** – A function or part performed in a particular operation or process.

**Rules Of Engagement (ROE)** – Describe how the ground-based and airborne threat simulators will operate during the test mission. ROE detail what restrictions the test requirements place on the threat simulator operators, particularly addressing target acquisition and reacquisition procedures and the use of EP features.

**Scenario** – A specific description of the many parameters characterising an encounter between one or more aircraft and a hostile air defence system or elements of that system.

**Self-Protection Jammer (SPJ)** – An EA system that protects the host platform.

**Sidelobes** – The lobes of the far field antenna radiation pattern that are not the main beam.

**Signals Intelligence (SIGINT)** – A category of intelligence comprising either individually or in combination all communications intelligence, electronic intelligence, and foreign instrumentation signals intelligence, however transmitted or intelligence derived from communications, electronic, and foreign instrumentation signals.

**Simulation** – A simulation is a method for implementing a model. It is the process of conducting experiments with a model for the purpose of understanding the behaviour of the system modelled under selected conditions or of evaluating various strategies for the operation of the system within the limits imposed by developmental or operational criteria. Simulation may include the use of analogue or digital devices, laboratory models, or “testbed” sites. Simulations are usually programmed for solution on a computer; however, in the broadest sense, military exercises, and wargames are also simulations.

**Simulator** – A system that can represent relevant characteristics of an actual threat system.

**Spectral** – Of or relating to the EM frequency characteristics of a signal.

**Stand-In Jamming** – A form of support jamming normally performed by Unmanned Aerospace Vehicles (UAV) operating within the engagement range of hostile air defence systems.

**Stand-Off Jamming (SOJ)** – A form of support jamming normally performed by manned aircraft operating outside the engagement range of hostile air defence systems.

**Statement Of Capability (SOC)** – A test facility’s response to a customer’s PID, documenting the cost, availability, and technical considerations or limitations.

**Stimulator** – A low fidelity piece of test equipment that can induce a desired response in a SUT without necessarily simulating the behaviour of an actual threat system.

**Suitability** – The degree to which a system can be placed and sustained satisfactorily in field use with consideration being given to availability, compatibility, transportability, interoperability, reliability, wartime usage rates, maintainability, safety, human factors, habitability, manpower, logistics supportability, natural environmental effects and impacts, documentation, and training requirements.

**Support Jamming** – Jamming conducted by one platform to protect another.

**Susceptibility** – The probability that an aircraft will be hit by a damage causing mechanism.

**Synthetic Environment** – Internetted simulations that represent activities at a high level of realism from simulations of theaters of war to factories and manufacturing processes. These environments may be created within a single computer or a vast distributed network connected by local and wide area networks and augmented by super-realistic special effects and accurate behavioural models. They allow visualization of and immersion into the environment being simulated.

**System Integration Laboratories (SIL)** – Facilities designed to test the performance and compatibility of components, sub-systems and systems when they are integrated with other systems or functions. They are used to evaluate individual hardware and software interactions and, at times, involve the entire weapon system avionics suite. A variety of computer simulations and test equipment are used to generate scenarios and environments to test for functional performance, reliability, and safety. SILs are generally weapon system specific and are found in both contractor and Government facilities.

**System Under Test (SUT)** – The test article. This can be a component, equipment, sub-system, system or whole platform with installed systems.

**Technology Readiness Level (TRL)** – One level on a scale of one to nine, e.g., “TRL 3,” signifying technology readiness pioneered by the National Aeronautics and Space Administration (NASA), adapted by the Air Force Research Laboratory (AFRL), and adopted by the Department of Defense as a method of estimating technology maturity during the acquisition process. The lower the level of the technology at the time it is included in a product development program, the higher the risk that it will cause problems in subsequent product development.

**TEMPEST** – Originally a codeword (hence capitalisation), since declassified. It is not an acronym. It refers to investigations and studies of compromising emissions. These are defined as unintentional intelligence-bearing signals which, if intercepted and analyzed, may disclose the information transmitted, received, handled, or otherwise processed by any information-processing equipment. NATO requirements defined in SDIP-27.

**Temporal** – Of or relating to the time domain.

**Test and Evaluation (T&E)** – Process by which a system or components are exercised and results analysed to provide performance related information. The information has many uses including risk identification and risk mitigation and empirical data to validate models and simulations. T&E enables an assessment of the attainment of technical performance, specifications, and system maturity to determine whether systems are operationally effective, suitable and survivable for intended use, and/or lethal.

**Test Conductor** – The individual responsible for the test point-by-test point execution of a test mission.

**Test Director** – The individual with overall responsibility for executing a test mission.

**Time, Space, Position Information (TSPI)** – Location data referenced to a coordinate system as a function of time.

**Towed Decoy** – A defensive EA system towed behind the host aircraft with the intent of providing a more seductive target to a threat system and one that creates an angle tracking error in the threat sensor system.

**Type I Error** – Rejecting null hypothesis when it is true.

**Type II Error** – Failing to reject a null hypothesis when it is false.

**Ultraviolet (UV)** – EM radiation with a wavelength shorter than that of visible light, but longer than X-rays, in the range 10 nm to 400 nm.



**Unmanned Aerospace Vehicles (UAV)** – An aerospace vehicle that is either remotely piloted or operates autonomously.

**Unmanned Aerospace Systems (UAS)** – UAS, which also means Unmanned Autonomous Systems, include UAVs and UCAVs (Unmanned Combat Air Vehicles).

**Vulnerability** – The conditional probability that an aircraft will be killed when struck by a damage causing mechanism.

**Wet** – A test condition where an EA SUT is operating in a transmitting mode.

**Wild Weasel** – An aircraft equipped with specialised receivers designed to detect, identify, and locate the source of hostile radar transmissions and ARMs to engage them.



## **Annex E – AGARD and RTO Flight Test Instrumentation and Flight Test Techniques Series**

### **1. Volumes in the AGARD and RTO Flight Test Instrumentation Series, AGARDograph 160**

Volume Number	Title	Publication Date
1.	Basic Principles of Flight Test Instrumentation Engineering (Issue 2) Issue 1: Edited by A. Pool and D. Bosman Issue 2: Edited by R. Borek and A. Pool	1974 1994
2.	In-Flight Temperature Measurements by F. Trenkle and M. Reinhardt	1973
3.	The Measurements of Fuel Flow by J.T. France	1972
4.	The Measurements of Engine Rotation Speed by M. Vedrunes	1973
5.	Magnetic Recording of Flight Test Data by G.E. Bennett	1974
6.	Open and Closed Loop Accelerometers by I. McLaren	1974
7.	Strain Gauge Measurements on Aircraft by E. Kottkamp, H. Wilhelm and D. Kohl	1976
8.	Linear and Angular Position Measurement of Aircraft Components by J.C. van der Linden and H.A. Mensink	1977
9.	Aeroelastic Flight Test Techniques and Instrumentation by J.W.G. van Nunen and G. Piazzoli	1979
10.	Helicopter Flight Test Instrumentation by K.R. Ferrell	1980
11.	Pressure and Flow Measurement by W. Wuest	1980
12.	Aircraft Flight Test Data Processing – A Review of the State of the Art by L.J. Smith and N.O. Matthews	1980
13.	Practical Aspects of Instrumentation System Installation by R.W. Borek	1981
14.	The Analysis of Random Data by D.A. Williams	1981
15.	Gyroscopic Instruments and Their Application to Flight Testing by B. Stieler and H. Winter	1982
16.	Trajectory Measurements for Take-off and Landing Test and Other Short-Range Applications by P. de Benque D'Agut, H. Riebeek and A. Pool	1985

17.	Analogue Signal Conditioning for Flight Test Instrumentation by D.W. Veatch and R.K. Bogue	1986
18.	Microprocessor Applications in Airborne Flight Test Instrumentation by M.J. Prickett	1987
19.	Digital Signal Conditioning for Flight Test by G.A. Bever	1991
20.	Optical Air Flow Measurements in Flight by R.K. Bogue and H.W. Jentink	2003
21.	Differential Global Positioning System (DGPS) for Flight Testing by R. Sabatini and G.B. Palmerini	2008
22.	Application of Fiber Optic Instrumentation by L. Richards, A.R. Parker Jr., W.L. Ko, A. Piazza and P. Chan	2012

## 2. Volumes in the AGARD and RTO Flight Test Techniques Series

Volume Number	Title	Publication Date
AG237	Guide to In-Flight Thrust Measurement of Turbojets and Fan Engines by the MIDAP Study Group (UK)	1979
The remaining volumes are published as a sequence of Volume Numbers of AGARDograph 300.		
1.	Calibration of Air-Data Systems and Flow Direction Sensors by J.A. Lawford and K.R. Nippres	1988
2.	Identification of Dynamic Systems by R.E. Maine and K.W. Iliff	1988
3.	Identification of Dynamic Systems – Applications to Aircraft Part 1: The Output Error Approach by R.E. Maine and K.W. Iliff	1986
	Part 2: Nonlinear Analysis and Manoeuvre Design by J.A. Mulder, J.K. Sridhar and J.H. Breeman	1994
4.	Determination of Antenna Patterns and Radar Reflection Characteristics of Aircraft by H. Bothe and D. McDonald	1986
5.	Store Separation Flight Testing by R.J. Arnold and C.S. Epstein	1986
6.	Developmental Airdrop Testing Techniques and Devices by H.J. Hunter	1987
7.	Air-to-Air Radar Flight Testing by R.E. Scott	1992
8.	Flight Testing under Extreme Environmental Conditions by C.L. Henrickson	1988
9.	Aircraft Exterior Noise Measurement and Analysis Techniques by H. Heller	1991
10.	Weapon Delivery Analysis and Ballistic Flight Testing by R.J. Arnold and J.B. Knight	1992
11.	The Testing of Fixed Wing Tanker & Receiver Aircraft to Establish Their Air-to-Air Refuelling Capabilities by J. Bradley and K. Emerson	1992
12.	The Principles of Flight Test Assessment of Flight-Safety-Critical Systems in Helicopters by J.D.L. Gregory	1994
13.	Reliability and Maintainability Flight Test Techniques by J.M. Howell	1994
14.	Introduction to Flight Test Engineering Issue 1: Edited by F. Stoliker Issue 2: Edited by F. Stoliker and G. Bever	1995 2005
15.	Introduction to Avionics Flight Test by J.M. Clifton	1996

16.	Introduction to Airborne Early Warning Radar Flight Test by J.M. Clifton and F.W. Lee	1999
17.	Electronic Warfare Test and Evaluation <sup>‡</sup> by H. Banks and R. McQuillan	2000
18.	Flight Testing of Radio Navigation Systems by H. Bothe and H.J. Hotop	2000
19.	Simulation in Support of Flight Testing by D. Hines	2000
20.	Logistics Test and Evaluation in Flight Testing by M. Bourcier	2001
21.	Flying Qualities Flight Testing of Digital Flight Control Systems by F. Webster and T.D. Smith	2001
22.	Helicopter/Ship Qualification Testing by D. Carico, R. Fang, R.S. Finch, W.P. Geyer Jr., Cdr. (Ret.) H.W. Krijns and K. Long	2002
23.	Flight Test Measurement Techniques for Laminar Flow by D. Fisher, K.H. Horstmann and H. Riedel	2003
24.	Precision Airdrop by M.R. Wuest and R.J. Benney	2005
25.	Flight Testing of Night Vision Systems in Rotorcraft by G. Craig, T. Macuda, S. Jennings, G. Ramphal and A. Stewart	2007 <sup>†</sup>
26.	Airborne Laser Systems Testing and Analysis by R. Sabatini and M.A. Richardson	2010
27.	Unique Aspects of Flight Testing Unmanned Aircraft Systems by A.E. Pontzer, M.D. Lower and J.R. Miller	2010
28.	Electronic Warfare Test and Evaluation by M. Welch and M. Pywell	2012

At the time of publication of the present volume, the following volumes are in preparation:

Reduced Friction Runway Testing

Safety and Risk Management

Aircraft Stores Compatibility Testing

---

<sup>‡</sup> Superseded by Volume 28.

<sup>†</sup> Volume 25 has been published as RTO AGARDograph AG-SCI-089.



<b>REPORT DOCUMENTATION PAGE</b>			
<b>1. Recipient's Reference</b>	<b>2. Originator's References</b>	<b>3. Further Reference</b>	<b>4. Security Classification of Document</b>
	RTO-AG-300 AC/323(SCI-203)TP/471 Volume 28	ISBN 978-92-837-0172-9	UNCLASSIFIED/ UNLIMITED
<b>5. Originator</b>	Research and Technology Organisation North Atlantic Treaty Organisation BP 25, F-92201 Neuilly-sur-Seine Cedex, France		
<b>6. Title</b>	Electronic Warfare Test and Evaluation		
<b>7. Presented at/Sponsored by</b>	The Systems Concepts and Integration Panel.		
<b>8. Author(s)/Editor(s)</b>	Mr. Martin Welch and Mr. Mike Pywell	<b>9. Date</b>	December 2012
<b>10. Author's/Editor's Address</b>	Multiple	<b>11. Pages</b>	314
<b>12. Distribution Statement</b>	There are no restrictions on the distribution of this document. Information about the availability of this and other RTO unclassified publications is given on the back cover.		
<b>13. Keywords/Descriptors</b>	Electronic attack Electronic protection Electronic warfare Electronic warfare support Flight test Hardware-in-the-loop Installed system test facilities Learning from experience	Lessons learned Measurement facilities Modelling and simulation Open air ranges System integration laboratories Test and evaluation Threat simulation	
<b>14. Abstract</b>	<p>Electronic Warfare (EW) Test and Evaluation (T&amp;E) is a complex and expensive undertaking. Practitioners must understand the subject matter to efficiently apply available test resources and cost effectively meet their test objectives. This revised EW T&amp;E handbook provides an overview of various types of EW systems and basic test methodologies. It also describes various test resources and discusses their associated strengths and limitations. Some typical problems are identified and discussed in a Learning from Experience section. A brief overview of some test resources and facilities across NATO and Partnership for Peace countries are provided along with points of contact to aid potential customers.</p>		





BP 25

F-92201 NEUILLY-SUR-SEINE CEDEX • FRANCE  
Télécopie 0(1)55.61.22.99 • E-mail [mailbox@cso.nato.int](mailto:mailbox@cso.nato.int)



**DIFFUSION DES PUBLICATIONS**  
**RTO NON CLASSIFIEES**

Les publications de l'AGARD et de la RTO peuvent parfois être obtenues auprès des centres nationaux de distribution indiqués ci-dessous. Si vous souhaitez recevoir toutes les publications de la RTO, ou simplement celles qui concernent certains Panels, vous pouvez demander d'être inclus soit à titre personnel, soit au nom de votre organisation, sur la liste d'envoi.

Les publications de la RTO et de l'AGARD sont également en vente auprès des agences de vente indiquées ci-dessous.

Les demandes de documents RTO ou AGARD doivent comporter la dénomination « RTO » ou « AGARD » selon le cas, suivi du numéro de série. Des informations analogues, telles que le titre et la date de publication sont souhaitables.

Si vous souhaitez recevoir une notification électronique de la disponibilité des rapports de la RTO au fur et à mesure de leur publication, vous pouvez consulter notre site Web ([www.sto.nato.int](http://www.sto.nato.int)) et vous abonner à ce service.

### CENTRES DE DIFFUSION NATIONAUX

#### ALLEMAGNE

Streitkräfteamt / Abteilung III  
Fachinformationszentrum der Bundeswehr (FIZBw)  
Gorch-Fock-Straße 7, D-53229 Bonn

#### BELGIQUE

Royal High Institute for Defence – KHID/IRSD/RHID  
Management of Scientific & Technological Research  
for Defence, National RTO Coordinator  
Royal Military Academy – Campus Renaissance  
Renaissancelaan 30, 1000 Bruxelles

#### CANADA

DSIGRD2 – Bibliothécaire des ressources du savoir  
R et D pour la défense Canada  
Ministère de la Défense nationale  
305, rue Rideau, 9<sup>e</sup> étage  
Ottawa, Ontario K1A 0K2

#### DANEMARK

Danish Acquisition and Logistics Organization (DALO)  
Lautrupbjerg 1-5, 2750 Ballerup

#### ESPAGNE

SDG TECIN / DGAM  
C/ Arturo Soria 289  
Madrid 28033

#### ESTONIE

Estonian Ministry of Defence  
Estonian National Coordinator for NATO RTO  
Sakala 1, Tallinn 15094

#### ETATS-UNIS

NASA Center for AeroSpace Information (CASI)  
7115 Standard Drive  
Hanover, MD 21076-1320

#### FRANCE

O.N.E.R.A. (ISP)  
29, Avenue de la Division Leclerc  
BP 72, 92322 Châtillon Cedex

#### GRECE (Correspondant)

Defence Industry & Research General  
Directorate, Research Directorate  
Fakinos Base Camp, S.T.G. 1020  
Holargos, Athens

#### HONGRIE

Hungarian Ministry of Defence  
Development and Logistics Agency  
P.O.B. 25, H-1885 Budapest

#### ITALIE

General Secretariat of Defence and  
National Armaments Directorate  
5<sup>th</sup> Department – Technological  
Research  
Via XX Settembre 123, 00187 Roma

#### LUXEMBOURG

*Voir Belgique*

#### NORVEGE

Norwegian Defence Research  
Establishment, Attn: Biblioteket  
P.O. Box 25  
NO-2007 Kjeller

#### PAYS-BAS

Royal Netherlands Military  
Academy Library  
P.O. Box 90.002  
4800 PA Breda

#### POLOGNE

Centralna Biblioteka Wojskowa  
ul. Ostrobramska 109  
04-041 Warszawa

#### PORTUGAL

Estado Maior da Força Aérea  
SDFCA – Centro de Documentação  
Alfragide, P-2720 Amadora

#### REPUBLIQUE TCHEQUE

LOM PRAHA s. p.  
o. z. VTÚLaPVO  
Mladoboleslavská 944  
PO Box 18  
197 21 Praha 9

#### ROUMANIE

Romanian National Distribution  
Centre  
Armaments Department  
9-11, Drumul Taberei Street  
Sector 6  
061353, Bucharest

#### ROYAUME-UNI

Dstl Knowledge and Information  
Services  
Building 247  
Porton Down  
Salisbury SP4 0JQ

#### SLOVAQUIE

Akadémia ozbrojených síl gen.  
M.R. Štefánika, Distribučné a  
informačné stredisko RTO  
Demänová 393, Liptovský Mikuláš 6  
031 06

#### SLOVENIE

Ministry of Defence  
Central Registry for EU and  
NATO  
Vojkova 55  
1000 Ljubljana

#### TURQUIE

Milli Savunma Bakanlığı (MSB)  
ARGE ve Teknoloji Dairesi  
Başkanlığı  
06650 Bakanlıklar  
Ankara

### AGENCES DE VENTE

**NASA Center for AeroSpace  
Information (CASI)**  
7115 Standard Drive  
Hanover, MD 21076-1320  
ETATS-UNIS

**The British Library Document  
Supply Centre**  
Boston Spa, Wetherby  
West Yorkshire LS23 7BQ  
ROYAUME-UNI

**Canada Institute for Scientific and  
Technical Information (CISTI)**  
National Research Council Acquisitions  
Montreal Road, Building M-55  
Ottawa K1A 0S2, CANADA

Les demandes de documents RTO ou AGARD doivent comporter la dénomination « RTO » ou « AGARD » selon le cas, suivie du numéro de série (par exemple AGARD-AG-315). Des informations analogues, telles que le titre et la date de publication sont souhaitables. Des références bibliographiques complètes ainsi que des résumés des publications RTO et AGARD figurent dans les journaux suivants :

#### Scientific and Technical Aerospace Reports (STAR)

STAR peut être consulté en ligne au localisateur de ressources  
uniformes (URL) suivant: <http://ntrs.nasa.gov/search.jsp>  
STAR est édité par CASI dans le cadre du programme  
NASA d'information scientifique et technique (STI)  
NASA Langley Research Center, STI Program Office, MS 157A  
Hampton, Virginia 23681-0001  
ETATS-UNIS

#### Government Reports Announcements & Index (GRA&I)

publié par le National Technical Information Service  
Springfield  
Virginia 2216  
ETATS-UNIS  
(accessible également en mode interactif dans la base de  
données bibliographiques en ligne du NTIS, et sur CD-ROM)



BP 25

F-92201 NEUILLY-SUR-SEINE CEDEX • FRANCE  
Télécopie 0(1)55.61.22.99 • E-mail [mailbox@cs0.nato.int](mailto:mailbox@cs0.nato.int)



**DISTRIBUTION OF UNCLASSIFIED  
RTO PUBLICATIONS**

AGARD & RTO publications are sometimes available from the National Distribution Centres listed below. If you wish to receive all RTO reports, or just those relating to one or more specific RTO Panels, they may be willing to include you (or your Organisation) in their distribution.

RTO and AGARD reports may also be purchased from the Sales Agencies listed below.

Requests for RTO or AGARD documents should include the word 'RTO' or 'AGARD', as appropriate, followed by the serial number. Collateral information such as title and publication date is desirable.

If you wish to receive electronic notification of RTO reports as they are published, please visit our website ([www.sto.nato.int](http://www.sto.nato.int)) from where you can register for this service.

**NATIONAL DISTRIBUTION CENTRES**

**BELGIUM**

Royal High Institute for Defence – KHID/IRSD/RHID  
Management of Scientific & Technological Research  
for Defence, National RTO Coordinator  
Royal Military Academy – Campus Renaissance  
Renaissancelaan 30  
1000 Brussels

**CANADA**

DRDKIM2 – Knowledge Resources Librarian  
Defence R&D Canada  
Department of National Defence  
305 Rideau Street, 9<sup>th</sup> Floor  
Ottawa, Ontario K1A 0K2

**CZECH REPUBLIC**

LOM PRAHA s. p.  
o. z. VTÚLaPVO  
Mladoboleslavská 944  
PO Box 18  
197 21 Praha 9

**DENMARK**

Danish Acquisition and Logistics Organization  
(DALO)  
Lautrupbjerg 1-5  
2750 Ballerup

**ESTONIA**

Estonian Ministry of Defence  
Estonian National Coordinator for NATO RTO  
Sakala 1, Tallinn 15094

**FRANCE**

O.N.E.R.A. (ISP)  
29, Avenue de la Division Leclerc  
BP 72, 92322 Châtillon Cedex

**GERMANY**

Streitkräfteamt / Abteilung III  
Fachinformationszentrum der Bundeswehr (FIZBw)  
Gorch-Fock-Straße 7  
D-53229 Bonn

**GREECE (Point of Contact)**

Defence Industry & Research General  
Directorate, Research Directorate  
Fakinos Base Camp, S.T.G. 1020  
Holargos, Athens

**HUNGARY**

Hungarian Ministry of Defence  
Development and Logistics Agency  
P.O.B. 25, H-1885 Budapest

**ITALY**

General Secretariat of Defence and  
National Armaments Directorate  
5<sup>th</sup> Department – Technological  
Research  
Via XX Settembre 123, 00187 Roma

**LUXEMBOURG**

See Belgium

**NETHERLANDS**

Royal Netherlands Military  
Academy Library  
P.O. Box 90.002  
4800 PA Breda

**NORWAY**

Norwegian Defence Research  
Establishment, Attn: Biblioteket  
P.O. Box 25  
NO-2007 Kjeller

**POLAND**

Centralna Biblioteka Wojskowa  
ul. Ostrobramska 109  
04-041 Warszawa

**PORTUGAL**

Estado Maior da Força Aérea  
SDFA – Centro de Documentação  
Alfragide, P-2720 Amadora

**ROMANIA**

Romanian National Distribution  
Centre  
Armaments Department  
9-11, Drumul Taberei Street  
Sector 6, 061353, Bucharest

**SLOVAKIA**

Akadémia ozbrojených síl gen.  
M.R. Štefánika, Distribučné a  
informačné stredisko RTO  
Demänová 393, Liptovský Mikuláš 6  
031 06

**SLOVENIA**

Ministry of Defence  
Central Registry for EU & NATO  
Vojkova 55  
1000 Ljubljana

**SPAIN**

SDG TECIN / DGAM  
C/ Arturo Soria 289  
Madrid 28033

**TURKEY**

Milli Savunma Bakanlığı (MSB)  
ARGE ve Teknoloji Dairesi  
Başkanlığı  
06650 Bakanlıklar – Ankara

**UNITED KINGDOM**

Dstl Knowledge and Information  
Services  
Building 247  
Porton Down  
Salisbury SP4 0JQ

**UNITED STATES**

NASA Center for AeroSpace  
Information (CASI)  
7115 Standard Drive  
Hanover, MD 21076-1320

**SALES AGENCIES**

**NASA Center for AeroSpace  
Information (CASI)**

7115 Standard Drive  
Hanover, MD 21076-1320  
UNITED STATES

**The British Library Document  
Supply Centre**

Boston Spa, Wetherby  
West Yorkshire LS23 7BQ  
UNITED KINGDOM

**Canada Institute for Scientific and  
Technical Information (CISTI)**

National Research Council Acquisitions  
Montreal Road, Building M-55  
Ottawa K1A 0S2, CANADA

Requests for RTO or AGARD documents should include the word 'RTO' or 'AGARD', as appropriate, followed by the serial number (for example AGARD-AG-315). Collateral information such as title and publication date is desirable. Full bibliographical references and abstracts of RTO and AGARD publications are given in the following journals:

**Scientific and Technical Aerospace Reports (STAR)**

STAR is available on-line at the following uniform resource

locator: <http://ntrs.nasa.gov/search.jsp>

STAR is published by CASI for the NASA Scientific  
and Technical Information (STI) Program

NASA Langley Research Center, STI Program Office, MS 157A  
Hampton, Virginia 23681-0001  
UNITED STATES

**Government Reports Announcements & Index (GRA&I)**

published by the National Technical Information Service

Springfield

Virginia 2216

UNITED STATES

(also available online in the NTIS Bibliographic Database  
or on CD-ROM)