

AN INNOVATIVE 6-DOF PLATFORM FOR TESTING A SPACE ROBOTIC SYSTEM TO PERFORM CONTACT TASKS IN ZERO-GRAVITY ENVIRONMENT

Ou Ma

**New Mexico State University
Department of Mechanical and Aerospace Engineering
1620 Standley Dr.
Las Cruces, NM 88003-1239**

21 Oct 2013

Final Report

APPROVED FOR PUBLIC RELEASE; DISTRIBUTION IS UNLIMITED.



**AIR FORCE RESEARCH LABORATORY
Space Vehicles Directorate
3550 Aberdeen Ave SE
AIR FORCE MATERIEL COMMAND
KIRTLAND AIR FORCE BASE, NM 87117-5776**

DTIC COPY NOTICE AND SIGNATURE PAGE

Using Government drawings, specifications, or other data included in this document for any purpose other than Government procurement does not in any way obligate the U.S. Government. The fact that the Government formulated or supplied the drawings, specifications, or other data does not license the holder or any other person or corporation; or convey any rights or permission to manufacture, use, or sell any patented invention that may relate to them.

This report is the result of contracted fundamental research deemed exempt from public affairs security and policy review in accordance with SAF/AQR memorandum dated 10 Dec 08 and AFRL/CA policy clarification memorandum dated 16 Jan 09. This report is available to the general public, including foreign nationals. Copies may be obtained from the Defense Technical Information Center (DTIC) (<http://www.dtic.mil>).

Qualified requestors may obtain copies of this report from the Defense Technical Information Center (DTIC) (<http://www.dtic.mil>).

**AFRL-RV-PS-TR-2013-0125 HAS BEEN REVIEWED AND IS APPROVED FOR
PUBLICATION IN ACCORDANCE WITH ASSIGNED DISTRIBUTION STATEMENT**

//SIGNED//
KHANH PHAM
Program Manager

//SIGNED//
PAUL HAUSGEN
Technical Advisor, Spacecraft Component Technology Branch

//SIGNED//
BENJAMIN M. COOK, Lt Col, USAF
Deputy Chief, Spacecraft Technology Division
Space Vehicles Directorate

This report is published in the interest of scientific and technical information exchange, and its publication does not constitute the Government's approval or disapproval of its ideas or findings.

REPORT DOCUMENTATION PAGE

Form Approved
OMB No. 0704-0188

Public reporting burden for this collection of information is estimated to average 1 hour per response, including the time for reviewing instructions, searching existing data sources, gathering and maintaining the data needed, and completing and reviewing this collection of information. Send comments regarding this burden estimate or any other aspect of this collection of information, including suggestions for reducing this burden to Department of Defense, Washington Headquarters Services, Directorate for Information Operations and Reports (0704-0188), 1215 Jefferson Davis Highway, Suite 1204, Arlington, VA 22202-4302. Respondents should be aware that notwithstanding any other provision of law, no person shall be subject to any penalty for failing to comply with a collection of information if it does not display a currently valid OMB control number. **PLEASE DO NOT RETURN YOUR FORM TO THE ABOVE ADDRESS.**

1. REPORT DATE (DD-MM-YYYY) 21-10-2013		2. REPORT TYPE Final Report		3. DATES COVERED (From - To) 15 Sep 2011 -15 Aug 2013	
4. TITLE AND SUBTITLE An Innovative 6-DOF Platform for Testing a Space Robotic System to Perform Contact Tasks in Zero-Gravity Environment				5a. CONTRACT NUMBER FA9453-11-1-0306	
				5b. GRANT NUMBER	
				5c. PROGRAM ELEMENT NUMBER 62601F	
6. AUTHOR(S) Ou Ma				5d. PROJECT NUMBER 8809	
				5e. TASK NUMBER PPM00013332	
				5f. WORK UNIT NUMBER EF005646	
7. PERFORMING ORGANIZATION NAME(S) AND ADDRESS(ES) New Mexico State University Department of Mechanical and Aerospace Engineering 1620 Standley Dr. Las Cruces, NM 88003-1239				8. PERFORMING ORGANIZATION REPORT NUMBER	
9. SPONSORING / MONITORING AGENCY NAME(S) AND ADDRESS(ES) Air Force Research Laboratory Space Vehicles Directorate 3550 Aberdeen Ave., SE Kirtland AFB, NM 87117-5776				10. SPONSOR/MONITOR'S ACRONYM(S) AFRL/RVSV	
				11. SPONSOR/MONITOR'S REPORT NUMBER(S) AFRL-RV-PS-TR-2013-0125	
12. DISTRIBUTION / AVAILABILITY STATEMENT Approved for public release; distribution is unlimited.					
13. SUPPLEMENTARY NOTES					
The specific aim of the project was to design and make a demonstration prototype of an innovative zero-gravity 6 degrees of freedom (6-DOF) test platform for experimentally studying and verifying the control technology for optimal space contact tasks and other future research along the same line. In the project, we designed a zero-gravity space robotics and satellite test platform based on a spring-based passive gravity compensation technology. The basic technology was developed by an NMSU multidisciplinary research team led by Dr. Ma with the support of a National Science Foundation (NSF) grant. This new satellite test platform is an actual application of the underlying gravity compensation technology. The major advantages of the technology are: it can passively compensate any amount of the gravity force as needed (adjustable from 0% to 100% compensation) in a full 3D or 6-DOF space, so that the tested object such as a satellite mockup attached to the platform will be completely free floating and rotating in all axes just like in the real space environment. Since the gravity compensation is done passively, the resulting system is reliable, inexpensive, easy to maintain and easy to operate. A hardware prototype of the platform has been built.					
15. SUBJECT TERMS Microgravity, zero gravity, test platform, simulation, gravity offloading					
16. SECURITY CLASSIFICATION OF:			17. LIMITATION OF ABSTRACT	18. NUMBER OF PAGES	19a. NAME OF RESPONSIBLE PERSON
a. REPORT Unclassified	b. ABSTRACT Unclassified	c. THIS PAGE Unclassified			Khanh Pham
			Unlimited	24	19b. TELEPHONE NUMBER (include area code)

(This page intentionally left blank)

TABLE OF CONTENTS

List of Figures.....	ii
List of Tables.....	ii
1 Summary.....	1
2 Introduction	2
3 Methods, Assumptions, and Procedures	3
3.1 Description of the Platform	3
3.2 Concept Design and Top Requirements	4
3.3 Principle of Gravity Offloading	5
4 Results and Discussion	7
4.1 Results	7
4.2 Conclusion and Discussion	11
5 Conclusions	12
References.....	13
APPENDIX: Education Efforts	14
List of Symbols, Abbreviations and Acronyms	15

LIST OF FIGURES

Figure 1. Concept design of the 6-DOF zero-gravity test platform	4
Figure 2. Assembly drawing of the 6-DOF zero-G test platform (perspective view).....	7
Figure 3. Assembly drawings of the test platform with annotations of main components	8
Figure 4. Exploded assembly of the 6-DOF zero-G test platform design	9
Figure 5. A hardware prototype of the 6-DOF 0-G test platform	11

LIST OF TABLES

Table 1. Top level design requirement of the test platform	5
--	---

ACKNOWLEDGEMENT AND DISCLAIMER

This material is based on research sponsored by Air Force Research Laboratory under agreement number FA9453-11-1-0306. The U.S. Government is authorized to reproduce and distribute reprints for Governmental purposes notwithstanding any copyright notation thereon.

The views and conclusions contained herein are those of the authors and should not be interpreted as necessarily representing the official policies or endorsements, either expressed or implied, of Air Force Research Laboratory or the U.S. Government.

(This page intentionally left blank)

1 SUMMARY

This is the final technical report of the Small University Research Project titled “An Innovative 6-DOF (Degrees of Freedom) Platform for Testing a Space Robotic System to Perform Contact Tasks in Zero-Gravity Environment”. The project was awarded to New Mexico State University (NMSU) in October 2011 and its goal was to develop enabling technologies for future robotic operations in space, such as a spacecraft with a robotic arm to rendezvous with and capture a non-cooperative flying object for on-orbit servicing. The research addresses the Air Force’s strategic needs for superior space situation awareness and space asset protection. The specific aim of the project was to design and manufacture a demonstration prototype of an innovative zero-gravity (0-G) test platform for experimentally studying and verifying the control technology for optimal space contact tasks and any future research along the same line. The project has been completed which includes the design, analysis, and the physical prototyping of the 6-DOF (6 degrees of freedom) zero-gravity test platform. Due to the uniqueness and many potential applications, a patent application of the design of this platform has been submitted to the US Patent Office.

2 INTRODUCTION

All the space systems designed for missions requiring physical interception with another flying object, such as space robots or servicing satellites, have to be thoroughly tested and verified regarding their contact dynamics performance in a simulated zero- or reduced-gravity environment before they can be launched to space. However, ground-based testing of contact dynamics of space systems is a very difficult problem because all the existing zero- or reduced-gravity test technologies are either too complicated and expensive or unsuitable for such testing. For example, the technology of using aircraft to fly a parabolic trajectory offers too short (about 20 seconds only) and non-smooth microgravity condition as well as very limited cargo space for setting up test system. The neutral buoyancy approach [1] suffers viscous drag, nonequivalent inertia, and sealing issues. Such a facility is also very difficult to access and expensive to operate. The counterweight based suspension method [2] does not allow free motion in all the 6-DOF and is also dynamically inaccurate because of too much extra inertia from the counterweights. The most popular technology widely used in industry is to use air-bearings on a flat floor to simulate free floating in space [3]. But that is only a 2D (2-dimension) testing method failing to simulate 3D (3-dimension) or 6-DOF zero-gravity contact dynamics. The virtual reality-based approach [4] emphasizes visual effect only and its motion portion is not real. The recently developed, robotics-based hardware-in-the-loop simulation systems such as the NASA's space shuttle docking simulator [5], Canadian Space Agency's (CSA's) Special Purpose Dexterous Manipulator (SPDM) Task Verification Facility (STVF) [6] and the German Space Agency's (DLR's) European Proximity Operations Simulator (EPOS) [7-8] can actively simulate 6-DOF contact dynamics behavior of spacecraft or space robots performing contact operations. However, these advanced systems are very complicated and thus, they are not only very expensive to develop and maintain but also highly concerned about the possibility of altering the contact dynamics behavior of the tested system (i.e., resulting in false test results). Hence, there exists a need to develop an innovative, zero-gravity contact dynamics simulation technology which is not only accurate but also inexpensive and easy to use. The proposed research addresses this need.

The aim of this research project is to design an innovative zero-gravity (0-G) 6-DOF test platform, as shown in Figure 1, for experimentally studying and demonstrating the advanced space robotics technologies. The design will emphasize the 0-G condition and full 6-degrees-of-freedom motion in 3D space as well as high reliability and low initial and operational costs. Due to the time and funding limitations of the project, we will focus only on the design and fabrication of a small-scale prototype of the test platform. Sufficient evidence will be generated to show the feasibility and fidelity of the designed test system.

3 METHODS, ASSUMPTIONS, AND PROCEDURES

This section describes the design of the 6-DOF platform for testing a free-floating spacecraft or space object in a zero-gravity environment.

3.1 Description of the Platform

The aim of this part of the research work is to design an innovative zero-gravity (0-G) test system for experimentally studying and demonstrating the advanced space robotics technologies developed in Sections 5 and 6 of this report as well as future research along the same line. The design emphasizes the 0-G condition and full 6-degrees-of-freedom motion in 3D space as well as high reliability and low initial and operational costs. Due to the time and funding limitations of the project, we are focusing only on the design and simulation-based analysis and demonstration of the new test system using a simplified prototype. Sufficient evidence will be generated to show the feasibility and fidelity of the designed test system. Physical prototyping of a full-scale experimental system will be planned for the next phase of the research project.

The 6-DOF test platform is being designed based on a spring-based passive gravity compensation technology which is currently being developed by an NMSU multidisciplinary research team led by Dr. Ma under an NSF (National Science Foundation) grant [9]. The platform being developed in this project is an application of the new gravity compensation technology. The major advantages of the technology are: it can compensate any amount of the gravity force (adjustable from 0% to 100% compensation) in a full 3D space, so that the tested object such as a satellite mockup in this case would experience a 0-G free floating condition just like in the space. The gravity compensation is done using a spring-based passive mechanism (without any actuators) and thus the system is reliable, inexpensive, and easy to maintain. It should be emphasized that, because the system is intended to test robot contact tasks (grasping, docking, touching, etc.) which occurs always in a very close range and thus the limited motion space (i.e., workspace of the mechanism) of the 0-G platform should not be a concern.

For instrumentation of the test system, joint encoders can be installed to measure the detailed motion state of the mechanism. A 3D Cartesian motion capture system (expensive but already available in Dr. Ma's lab) will be used to capture the 3D motion data of the tested objects. A force-moment sensor can be installed between the platform and the tested object to measure the resultant contact force and moment applied to the tested object during a capture process. A load cell or potentiometer can be attached to each spring for indirect force measurement. These sensor data can be integrated and analyzed to provide a good characterization and performance of the space robot for the intended tasks or applications with or without interception.

The test platform has advantages over the traditional 0-G test technologies because it can test 6-DOF motion in a full 3D space. Further, it is a passive system and thus very reliable and inexpensive to maintain and operate. In the project, the research team will design this new 0-G space robotics test system in detail and perform a simulation based analysis of the dynamics characteristics and performance of the system. The questions to be answered by the study are: 1) what level of fidelity can the test system provide in terms of 0-G condition and full 6-DOF dynamics? 2) How much workspace is available with the test system for simulating satellite

interception? 3) Are there any singularities which need to be dealt with during operation of the 0-G mechanisms? 4) What is the impact to the intended application from the joint friction and possible structure vibrations of the mechanisms? 5) What are the limitations of the new test system?

3.2 Concept Design and Top Requirements

Since the zero-gravity platform is used to test a satellite (hardware mockup) free floating in the space, it has to provide a full 6-DOF maneuverability and be fully compensated for the weight of the satellite in all the 6 DOFs. Based on these two fundamental requirements, we propose a concept design of the prototype, as shown in Figure 1. The mechanism consists of four major sections, namely, an inner arm, an outer arm, a gimbal and a satellite, as marked with different colors in the figure. The mechanism has many rotational joints but only 6 of them are independent, which provides a 6-DOF motion of the satellite at its far end (tip). The rotational angles of the 6 independent 1-DOF joints are denoted by $\theta_1, \theta_2, \dots, \theta_6$, respectively. The key geometric dimensions are described by l_i, r_i , and d_i ($i = 1, 2, \dots, 6$). Note that, if a dimension is zero or irrelevant to our design analysis, it will not be marked in the concept diagram. Further, the masses of the individual sections are marked as m_1, m_2, \dots, m_6 where m_6 is the mass of the satellite. It is further assumed that the mass center of the satellite is coincident with the pivoting center of the 3D gimbal.

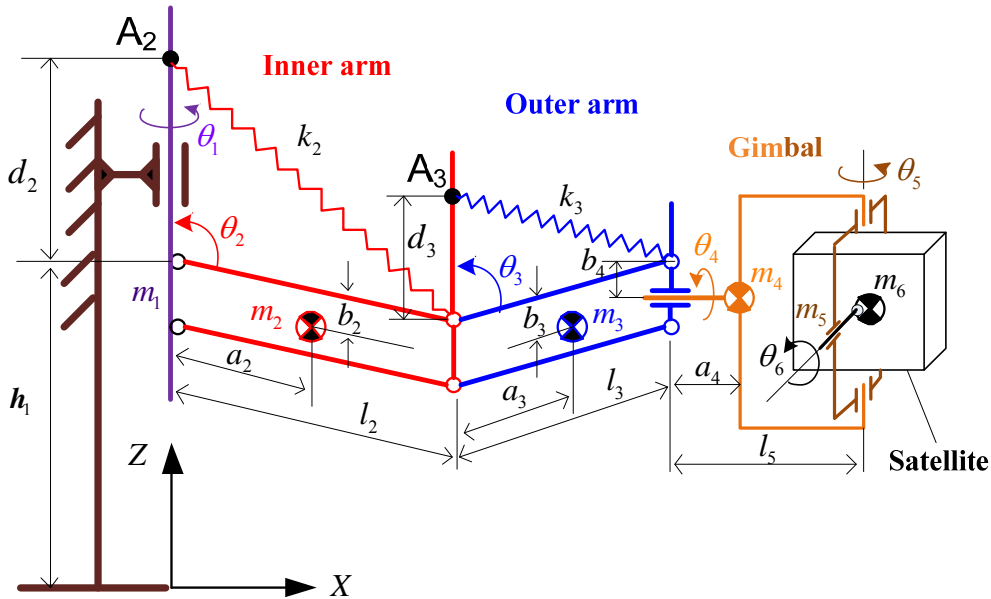

Figure 1. Concept design of the 6-DOF zero-gravity test platform

Since the scale prototype is designed for desktop demonstration of the zero-gravity test platform only, we have proposed a set of top-level design requirements (in Table 1) as the basis for our design of the hardware prototype.

Table 1. Top level design requirement of the test platform

Requirements	Specifications	Remarks
Total Degrees of Freedom	6-DOF	3-DOF Stand and 3-DOF Gimbal
Horizontal Motion Range	12 ~ 16 inches	3-DOF Stand
Vertical Motion Range	12 ~ 16 inches	3-DOF Stand
Rotational Motion Range	360°	3-DOF Stand
Satellite Pitch	360°	3-DOF Gimbal
Satellite Roll	360°	3-DOF Gimbal
Satellite Yaw	90° (minimum)	3-DOF Gimbal
Scale Satellite Weight Range	2 ~ 5 pounds	See Note 1
Scale Satellite Length	4 ~ 6 inches	Hexagon Shape
Scale Satellite Height	4 ~ 6 inches	Hexagon Shape
Scale Satellite Width	28 ~ 32 inches	Including Solar Panels
Maximum System Height	36 ~ 48 inches	Based on Extended Spring Length
Maximum System Length	36 ~ 48 inches	Satellite at Maximum Horizontal Displacement
Gravity offloading level	Zero gravity	All the weight is offloaded

3.3 Principle of Gravity Offloading

To achieve the zero gravity condition of the test satellite, the platform mechanism including the test satellite must be statically balanced. This means that the total potential energy of the mechanism contributed by both the gravity field and the springs remains constant for all the working configurations of the mechanism in its workspace [10]. This can be mathematically described as

$$V_{Total} = V_m + V_s = \text{Constant} \quad (1)$$

where, V_m and V_s represent the potential energies of the mechanism including the satellite and the springs in the system, respectively. Under the condition given by Eq. (1), all the gravity effect should be reduced to zero. The total potential energy of a general 6-DOF statically balanced mechanism can be expressed in terms of the joint angles, θ_i , ($i=1,2,\dots,6$), as follows [11]:

$$V_{Total} = V_M + V_S = C_0 + \sum_{i=1}^6 C_i \cos \theta_i = \text{constant} \quad (2)$$

where C_0 is a constant and all the other coefficients C_1, C_2, \dots, C_6 must be zero.

Based on the concept design shown in Figure 1, the total potential energy can be expressed as follows:

$$\begin{aligned}
V_{Total} = & (h_1 + a_2 \cos \theta_2 - b_2)m_2g + (h_1 + l_2 \cos \theta_2 + a_3 \cos \theta_3 - b_3)m_3g \\
& + (h_1 + l_2 \cos \theta_2 + l_3 \cos \theta_3 - b_4)(m_4 + m_5 + m_6)g \\
& + \frac{1}{2}k_2(d_2^2 + l_2^2 - 2d_2l_2 \cos \theta_2) + \frac{1}{2}k_3(d_3^2 + l_3^2 - 2d_3l_3 \cos \theta_3)
\end{aligned} \tag{3}$$

where g is the gravity acceleration and all the other parameters have been defined in Figure 1. Comparing equations (2) and (3), we can easily find the coefficients of equation (2):

$$\begin{aligned}
C_0 = & (h_1 - b_2)m_2g + (h_1 - b_3)m_3g + (h_1 - b_4)(m_4 + m_5 + m_6)g + \frac{1}{2}k_2(d_2^2 + l_2^2) + \frac{1}{2}k_3(d_3^2 + l_3^2) \\
C_2 = & a_2m_2g + l_2m_3g + l_2(m_4 + m_5 + m_6)g - k_2d_2l_2 \\
C_3 = & a_3m_3g + l_3(m_4 + m_5 + m_6)g - k_3d_3l_3 \\
C_1 = & C_4 = C_5 = C_6 = 0
\end{aligned} \tag{4}$$

Based on equation (2) for full gravity offloading, C_2 and C_3 must be zero, from which we can determine the stiffness values of the two springs of the mechanism

$$\begin{aligned}
k_2 = & \frac{a_2m_2 + l_2m_3 + l_2(m_4 + m_5 + m_6)}{d_2l_2} g \\
k_3 = & \frac{a_3m_3 + l_3(m_4 + m_5 + m_6)}{d_3l_3} g
\end{aligned} \tag{5}$$

Clearly, such a set of springs will keep the total potential energy of the system constant for any configuration of the mechanism, because now the total potential energy is independent of the configuration variables. In other words, the gravity effect on the mechanism itself and the attached satellite will be fully compensated.

Note that the set of springs defined by Eq. (5) is only capable of reducing the gravity for a particular satellite because the determined spring stiffness values are dependent on the specific mass of the satellite, i.e., the parameter m_6 . This means, when the platform is used to test a different satellite, a new set of springs with different stiffness values has to be installed. Obviously, this is inconvenient in practice. A solution to this problem is to use the same set of springs for every satellite but leave the springs' attachment points adjustable, namely, to change the d_2 and d_3 values for a different satellite. For example, one can vertically adjust the spring attachment points A_2 and A_3 , as indicated in Figure 1, based on the mass property of the satellite attached to the platform. The amount of adjustment is based on the same conditions given by Eq. (4), which can be found to be

$$\begin{aligned}
d_2 = & \frac{a_2m_2 + l_2m_3 + l_2(m_4 + m_5 + m_6)}{k_2l_2} g \\
d_3 = & \frac{a_3m_3 + l_3(m_4 + m_5 + m_6)}{k_3l_3} g
\end{aligned} \tag{6}$$

where the spring stiffness k_2 and k_3 are fixed values. These relations also allow us to adjust the mechanism to compensate any small errors in the known mass of the satellite.

4 RESULTS AND DISCUSSION

4.1 Results

Based on the concept design shown in Figure 1 and the design requirements specified in Table 1, we designed a prototype of the test platform. Figures 2, 3 and 4 show the assembly drawings of the design in two different views. We will not present all the detailed component drawings in the report because they will take up too much space while not contributing to the description of the design innovation.

The mechanical system is comprised of off-the-shelf items along with custom fabricated components. For this prototype we choose as many off-the-shelf items as possible that could be used as designed or modified to fit our particular application.

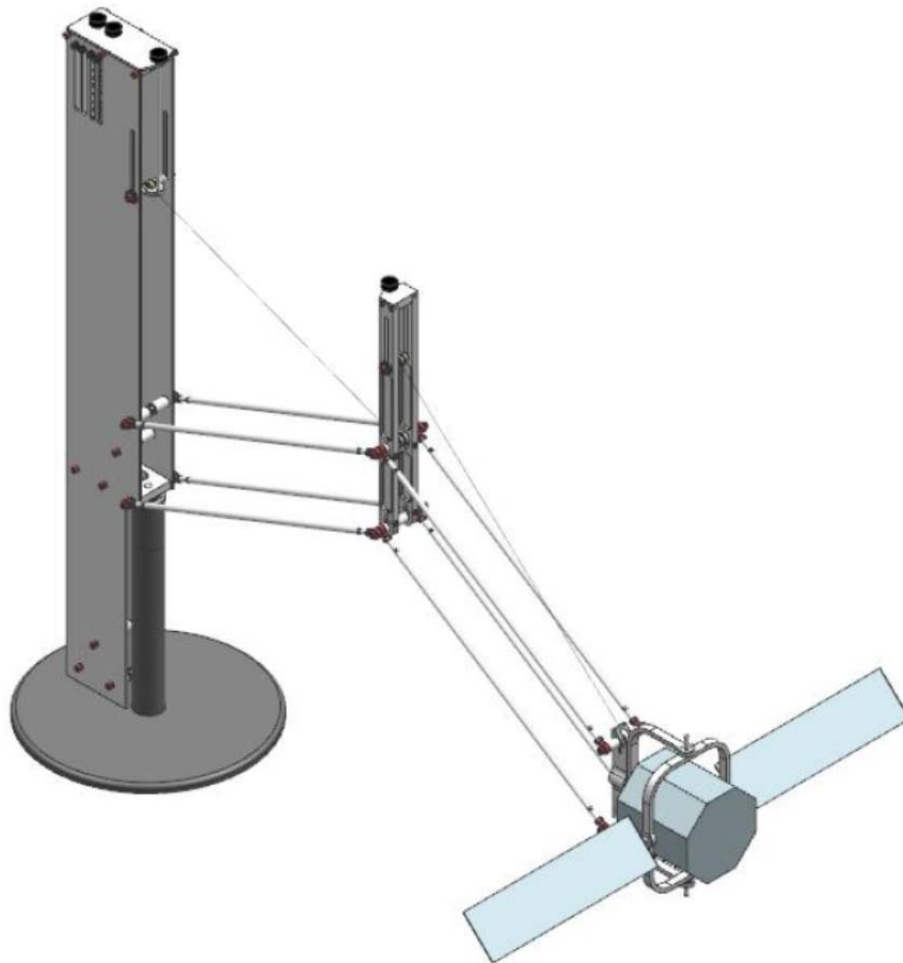

Figure 2. Assembly drawing of the 6-DOF zero-G test platform (perspective view)

Mounting the satellite to the system will have to be based on the customer recommendations. On the prototype we used the shafts that attach the simulated solar panels to the main body as this is a convenient point that is coaxial to one of the pivot axis.

The selection of the springs is first determined through analysis as described in the design phase: $k_2 = 0.414$ lb/in and $k_3 = 1.006$ lb/in . These calculated data must be adjusted by hardware experiment in the integration phase. The latter step is necessary because the analysis was based on a theoretical model of the system and perfect design data, which do not perfectly match the manufactured hardware. For example, the theoretical analysis cannot include all the manufacturing tolerances, friction, component deflections, etc. and thus, the analytically computed spring parameters have to be finalized after the hardware components are made and assembled. Once the spring parameters (the dimensions and stiffness values) were determined, we purchased the best matching spring products in the market (we could not order customer-built springs for this small phase-I project). Two spring adjustment knobs (see Figure 3 or 4) are designed to adjust the stretch and thus the initial force of the springs which will take care of the slight mismatch of the expected springs and the ones we purchased from the market.

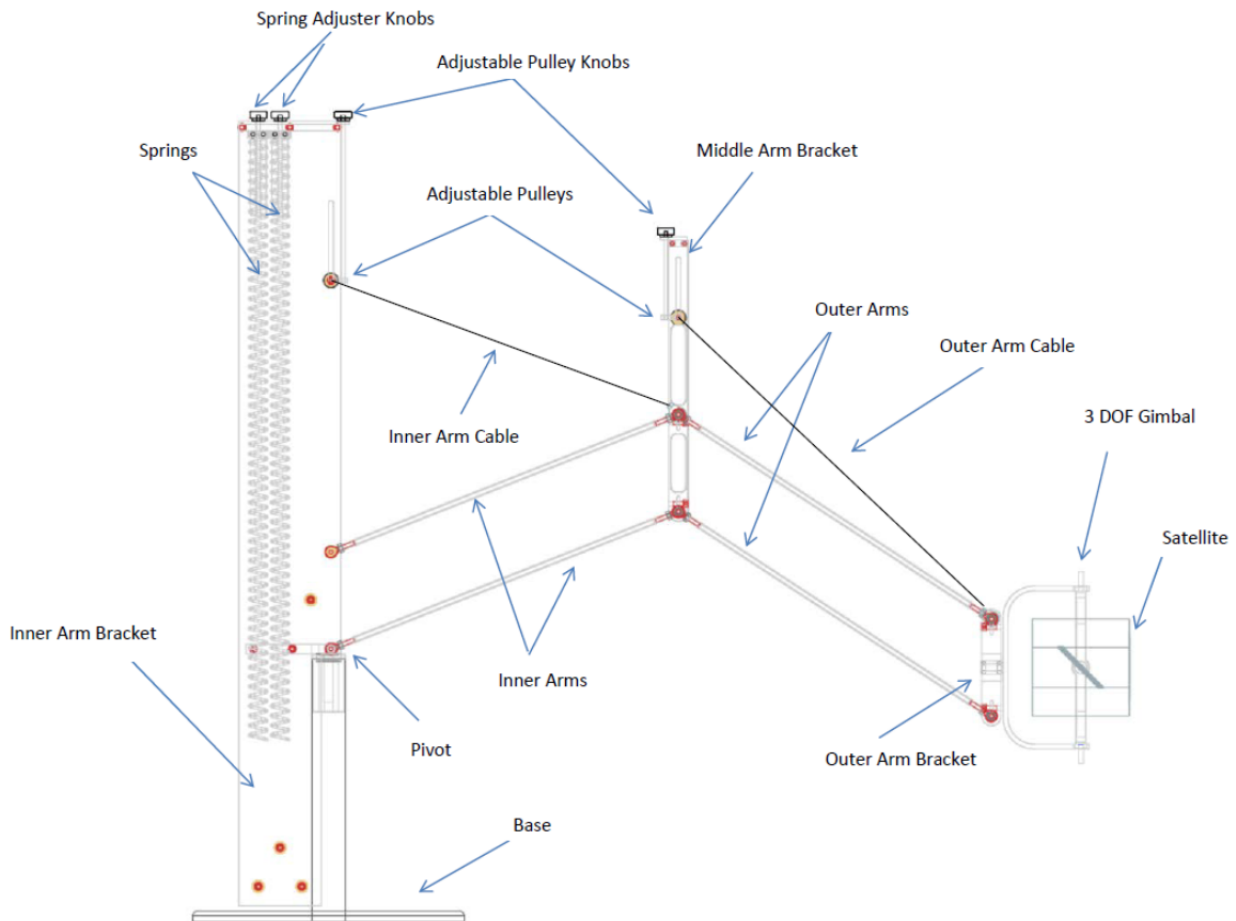

Figure 3. Assembly drawings of the test platform with annotations of main components

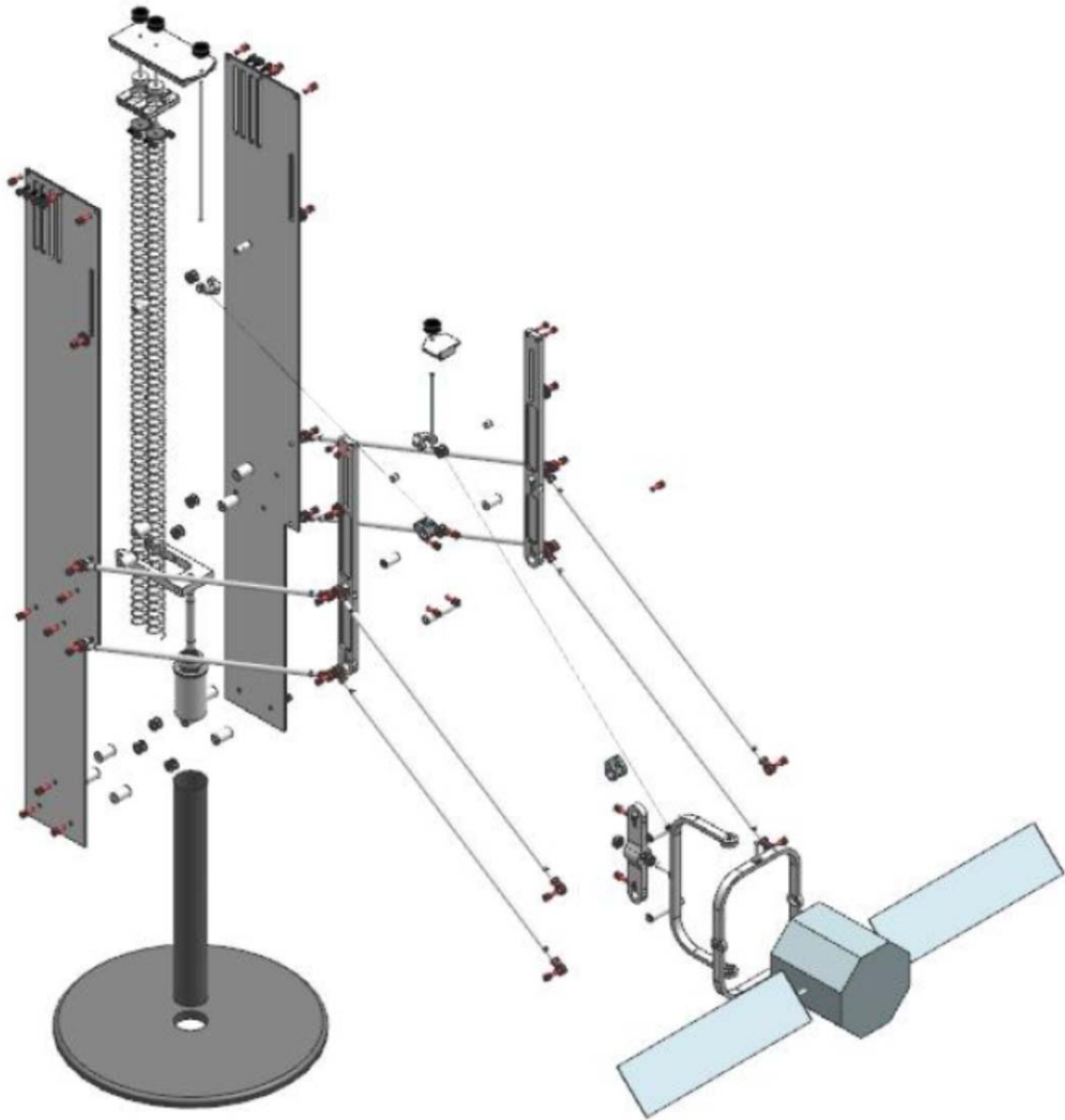

Figure 4. Exploded assembly of the 6-DOF zero-G test platform design

Other than the two spring adjustment knobs, another two adjusting knobs (see Figure 3) are designed to adjust the pulley positions. The pulley adjustment knobs adjust the positions of the pulleys for the inner and outer arms.

All the above-mentioned knobs in the scale prototype are to be manually adjusted. They are mechanically locked once the right adjustment positions have been reached. Should we design and build a full-scale prototype in the future, these spring and pulley adjustments will be automatically controlled by a mechatronic system.

Based on a preliminary design, we found that the highest tension force on the system is 17.9 lbf, being applied by the outer arm spring with the lowest D-distance geometry. The longest spring stretch that the system will see is 28.73 in. to balance the system with the full workspace of the mechanism. This indicates that the system will need to be greater than 30 in. in height to house the springs throughout the workspace of the mechanism.

On the scale prototype the satellite mass center adjustments are built into the mock-up satellite. This allows the operator to adjust the mass center of the satellite to coincide with the common pivot point of all the three axes of the 3-DOF gimbal. Should we design and build a full-scale prototype in the future, we will have to determine how to make such adjustment automatically. The mass center adjustments will be incorporated into the interface mount that attaches the satellite to the 3-DOF gimbal.

Based on the design described in Section 3, we manufactured a hardware prototype of the platform, as shown in Figure 5. After the system is tuned to be fully balanced, it can freely rotate in all the three axes. Our testing indicates that the satellite mockup of 1-kg on the platform requires an applied force of no more than 0.4 N on the payload to make it start moving in the vertical or radial direction and a force of less than 0.04 N to make it start moving in the lateral direction. This force reflects a combination of the joint friction torques and the inertia force of the mechanism. Since this force is caused by the joint friction and the system inertia, the lower the joint friction and the platform mass are, the higher the simulation fidelity of the system will have. Therefore, in the design of such a 0-G simulation platform, one should select joint bearings with low friction and make the mechanism as lightweight as possible. Regarding the rotation, a much smaller force, such as a tiny air flow in the room can cause the payload to rotate. Without interruption, the satellite can keep rotating for several minutes before it stops.

Since the system is completely passive, it is particularly suitable for simulating a free floating or tumbling object such as an inactive satellite to be served or a piece of orbital debris to be captured by a space robot on an on-orbit service mission. If the floating or tumbling motion of the payload requires it to be regulated for a specific application, the payload can be actuated by installing six small actuators on six independent joints of the mechanism. Only small actuators are required to control the motion of the payload because all the weight of the system has been compensated and only six actuators are needed because the system has only six degrees of freedom. Making the system actively actuated and controlled has the advantage of compensating the joint friction torques. However, an active simulation platform must use a sophisticated control strategy to guarantee the natural impedance of the tested payload when the payload encounters physical interaction with an external system such as in a capture or docking operation scenario [12]. A passive simulation system does not have such an issue.

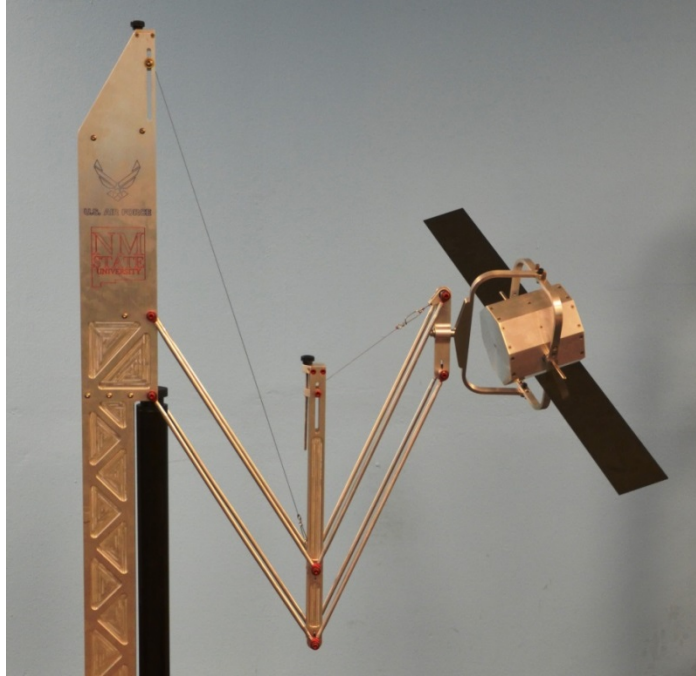

Figure 5. A hardware prototype of the 6-DOF 0-G test platform

4.2 Conclusion and Discussion

A new and low-cost zero-gravity (microgravity) simulation technology was developed, which allows 6-DOF testing of a free floating and tumbling satellite or another space object. A simulation platform designed based on the technology can compensate both its own weight and its payload's weight at all working configurations of the system, such that the payload can freely move and rotate in the simulated weightless condition. The gravity balancing is done by properly selecting the stiffness values or the attachment locations of the springs of the mechanism. A hardware prototype of the simulation platform has been designed, fabricated and tested. The tests demonstrated that a payload (a satellite mockup) on the platform can be kept free floating until it reaches the limit of the mechanism's workspace and free rotating for several minutes before it stops. The system can also be easily turned into an active system by installing six small actuators because all the weight of the system has been fully compensated. It can be used to test free floating and tumbling of a satellite or another space object in 3D space for scientific studies or engineering tests of various on-orbit service technologies such as target tracking, motion-state estimating, rendezvousing and docking, robotic capturing, or other service tasks. The current system requires manual tuning for the gravity balancing after assembly. This can be made automatic when an actuator and controller are installed at one end of each spring but this additional feature is out of the scope of this project.

5 CONCLUSIONS

We have accomplished the proposed objective of this project that is to design and manufacture a small-scale prototype of an innovative, 6-DOF, zero-gravity test platform for (physically) simulating free floating and free rotating of a satellite. The prototype has been demonstrated at AFRL/RV and we have received very positive feedbacks from the AFRL researchers who saw the prototype. Many interesting potential applications of the prototype for future research have been suggested, such as the study of visual tracking of satellites, the investigation of fuel sloshing and the testing of robotic capturing technology. A patent application of the design of this unique platform has been submitted in order to protect the intellectual property produced by this research work.

REFERENCES

- [1] Griffin B.N., "Zero-G Simulation Verifies EVA Servicing of Space Station Modules," *AIAA Space Station in the Twenty-First Century*, AIM-86-2312, Reno, Nevada, 1986.
- [2] Fujii H., Uchiyama K., Yoneoka H., and Maruyama T., "Ground-based simulation of space manipulators using test bed with suspension system," *Journal of Guidance, Control, and Dynamics*, Vol. 1997, No. 5, pp. 985-991.
- [3] Schwartz, J.L., Peck, M.A., and Hall, C.D., "Historical review of airbearing spacecraft simulators," *AIAA J. Guidance, Ctrl, Dyn.*, Vol.26(4), 2002, pp. 513-522.
- [4] Homan, D.J. and Gott, C.J., "An integrated EVA/RMS virtual reality simulation, including force feedback for astronaut training," *Proceedings of the AIAA Flight Simulation Technologies Conference*, San Diego, CA, Technical Papers (A96-35001 09-01), Reston, VA, 1996.
- [5] Roe F.D., Howard R.T., and Murphy L., "Automated rendezvous and capture system development and simulation for NASA," *Proc. SPIE*, Vol. 5420; doi:10.1117/12.542529, 2004.
- [6] Ma, O., Wang J., Misra S., and Liu M., "On the validation of SPDM task verification facility," *Journal of Robotic Systems*, Vol. 21, No. 5, 2004, pp. 219-235.
- [7] Boge T., Wimmer T., Ma O., Tzschichholz T., "EPOS – using robotics for RvD simulation of on-orbit servicing missions," *Proc. of the 2010 AIAA Simulations Technologies Conf.*, Aug. 2-5, 2010, Toronto, Paper #AIAA-2010-7788.
- [8] Ma, O., Flores-Abad, A. and Boge, T., "Control of Industrial Robots for Hardware-in-the-Loop Simulation of Satellite Docking," *Acta Astronautica*. Vol. 81, 2012, pp. 335-347.
- [9] Ma, O., Lu, Q., McAvoy, J., and Ruble, K., "Concept study of a passive reduced-gravity simulator for training astronauts," *Proc. ASME 2010 Intl. Design Eng. Tech. Conf. (IDETC)*, Aug. 15-18, Montreal, Canada, 2010.
- [10] Lu, Q., Ortega, C. and Ma, O., "Passive Gravity Compensation Mechanisms: Technologies and Applications," *Recent Patents on Engineering*, Vol. 5, Issue 1, 2011, pp. 32-44.
- [11] Ma, O., Ruble, K., Tessier, R., and Krech, E., "A New Technology for Physically Simulating 3D Free Floating and Rotating of an Object in Zero-Gravity Environment," *Proc. AIAA Modeling and Simulation Technologies Conference*, Aug. 19-22, 2013, Boston, MA, Paper #AIAA-2013-4677.
- [12] Ma, O., Flores-Abad, A. and Boge, T., "Use of industrial robots for hardware-in-the-loop simulation of satellite rendezvous and docking," *Acta Astronautica*, Vol. 81(1), 2012, pp. 335-347.

APPENDIX: EDUCATION EFFORTS

Although the project was relatively small in scope, Dr. Ma made special efforts to train as many students as possible through the project. He formed a research team consisting of an engineer and several students at different levels from high school all the way to Ph.D. as described next.

Staff and Student Participants:

- 1) Ken Ruble: Research engineer, Department of Mechanical and Aerospace Engineering, NMSU. Mr. Ruble was responsible for the design, manufacturing, and testing of the hardware prototype.
- 2) Samuel King, undergraduate student, Department of Mechanical and Aerospace Engineering, NMSU. Mr. King assisted in the mechanical design and manufacturing of the hardware components.
- 3) Jason Wright, undergraduate student, Department of Mechanical and Aerospace Engineering, NMSU, who assisted with the mechanical design and testing of the hardware prototype.
- 4) Bandon Mee, Santa Fe Community College, assisted Ken Ruble with mechanical drawings of the components of the hardware prototype.
- 5) Rachel Tessier, high school student, Las Cruces Mayfield High School, assisted Ken Ruble with mechanical drawings of the components of the hardware prototype.

All the team members worked on the project on a part-time basis because of their other education and research commitments at their schools. The mix of students in graduate, undergraduate and high school levels provided an excellent educational platform to train students which is mutually beneficial to all the participants. For example, the lower level students gained knowledge and skills from the help of the higher level students. On the other hand, the higher level students gained experience from their supervising, organizing and coordinating the research work with the lower level students. Further, in most times their knowledge, skills and training were complementary to the project and thus, they were synergetic when working together as a team.

Recruited Students:

Both Brandon Mee and Rachel Tessier have been recruited to the College of Engineering of NMSU after they worked on this project. They are both NMSU students right now.

List of Symbols, Abbreviations and Acronyms

CSA: Canadian Space Agency.

DOF: Degree of Freedom

DLR: German Space Agency

EPOS: European Proximity Operations Simulator

NMSU: New Mexico State University

NSF: National Science Foundation

SPDM : Special Purpose Dexterous Manipulator

STVF: SPDM Task Verification Facility

0-G: Zero-gravity.

2D: 2-Dimensions.

3D: 3-Dimensions.

θ_i : Rotational angles, $i=1, 2, 3, \dots, 6$.

l_i, r_i and d_i : Key geometric dimensions, $i=1, 2, 3, \dots, 6$.

m_i : Mass of i -th body, $i=1, 2, 3, \dots, 6$.

V : Potential Energy.

k_i : Stiffness Constant of Spring i , $i=1, 2, 3$.

DISTRIBUTION LIST

DTIC/OCP 8725 John J. Kingman Rd, Suite 0944 Ft Belvoir, VA 22060-6218	1 cy
AFRL/RVIL Kirtland AFB, NM 87117-5776	2 cys
Official Record Copy AFRL/RVSV/Khanh Pham	1 cy