

MODELING AND SIMULATION OF CARBON NANOTUBE ANTENNAS – COMPUTATIONAL CHALLENGES

George W. Hanson, Ruilian Li
Department of Electrical Engineering
University of Wisconsin-Milwaukee
Milwaukee, Wisconsin 53211

Dawei Wang, John Huang, Zhen Yu, and Steffen McKernan
RF Nano Corporation
4311 Jamboree Rd. Ste. 150
Newport Beach, CA 92660

Christopher Rutherglen, Peter Burke
Department of Electrical and Computer Engineering
University of California-Irvine
Engineering Gateway 2232
Irvine, CA 92697-2625

Dan McCarthy
United States Air Force Research Laboratory
525 Brooks Road
Rome, NY 13441

ABSTRACT

Carbon nanotube antennas and antenna arrays are discussed as possible nanoantennas in the GHz frequency range. Due to their exceedingly small radius, carbon nanotubes present unique measurement and simulation challenges, unlike those encountered in ordinary antenna applications. In this paper, we present preliminary results for measurement and simulation of carbon nanotube based antennas.

Keywords: carbon nanotube, nanoantenna, antenna array

1. Introduction

Fundamental properties and potential applications of nanoscopic and mesoscopic systems are of great current interest. An important consideration is establishing a wireless communication link, and/or wireless power transfer, to nanoscopic circuits and devices. Obviously, for interfacing with a nanoscale device, a similarly physically small antenna would be desirable. Potential applications are to inter- and intra-chip communications, and to ultra-small autonomous electrical-mechanical devices.

Particularly important components in emerging electronic applications are carbon nanotubes (CNs). Single-wall

carbon nanotubes (SWCNTs) are hollow tubes with the tube wall being a mono-atomic layer of hexagonally-bonded carbon atoms [1]. Carbon nanotubes have typical radius values of 1-2 nanometers, and lengths into the centimeter range. They have very desirable mechanical and electrical properties; carbon nanotubes have the highest tensile strength and thermal conductivity of any known material, and can be metallic or semiconducting. Carbon nanotubes can support much higher current densities than ordinary metals, and are stable and resistant to electromigration. The conductivity of metallic carbon nanotubes is much larger than metal wires at similar radius sizes (in general, sub-50 nanometer radius metal wires have much lower conductivity compared to bulk material, due to grain boundary scattering, surface scattering, and fabrication difficulties, and these problems are particularly severe below 10 nm). Some resistance measurements on SWCNTs are reported in [2]-[3].

Given the possibility of centimeter lengths, carbon nanotubes are natural candidates for wire-like antennas in the GHz-THz range. Wave velocities tend to be approximately 100 times slower on carbon nanotubes (and on other nano-radius conductors) than on macro-radius wire antennas, leading to shorter resonant devices. However, their extremely small radius leads to large input impedances, large resistive losses, and very low radiation efficiencies. Dense arrays of carbon nanotubes or other

Report Documentation Page

Form Approved
OMB No. 0704-0188

Public reporting burden for the collection of information is estimated to average 1 hour per response, including the time for reviewing instructions, searching existing data sources, gathering and maintaining the data needed, and completing and reviewing the collection of information. Send comments regarding this burden estimate or any other aspect of this collection of information, including suggestions for reducing this burden, to Washington Headquarters Services, Directorate for Information Operations and Reports, 1215 Jefferson Davis Highway, Suite 1204, Arlington VA 22202-4302. Respondents should be aware that notwithstanding any other provision of law, no person shall be subject to a penalty for failing to comply with a collection of information if it does not display a currently valid OMB control number.

1. REPORT DATE 2009		2. REPORT TYPE		3. DATES COVERED 00-00-2009 to 00-00-2009	
4. TITLE AND SUBTITLE Modeling and Simulation of Carbon Nanotube Antennas - Computational Challenges				5a. CONTRACT NUMBER	
				5b. GRANT NUMBER	
				5c. PROGRAM ELEMENT NUMBER	
6. AUTHOR(S)				5d. PROJECT NUMBER	
				5e. TASK NUMBER	
				5f. WORK UNIT NUMBER	
7. PERFORMING ORGANIZATION NAME(S) AND ADDRESS(ES) University of Wisconsin-Milwaukee, Department of Electrical Engineering, Milwaukee, WI, 53211				8. PERFORMING ORGANIZATION REPORT NUMBER	
9. SPONSORING/MONITORING AGENCY NAME(S) AND ADDRESS(ES)				10. SPONSOR/MONITOR'S ACRONYM(S)	
				11. SPONSOR/MONITOR'S REPORT NUMBER(S)	
12. DISTRIBUTION/AVAILABILITY STATEMENT Approved for public release; distribution unlimited					
13. SUPPLEMENTARY NOTES 30th Antenna Measurement Technique Association Annual Symposium, Boston, MA USA Source: 30th Antenna Measurement Technique Association Annual Symposium Pages: 77-81 (2009). U.S. Government or Federal Rights License					
14. ABSTRACT Carbon nanotube antennas and antenna arrays are discussed as possible nanoantennas in the GHz frequency range. Due to their exceedingly small radius, carbon nanotubes present unique measurement and simulation challenges, unlike those encountered in ordinary antenna applications. In this paper, we present preliminary results for measurement and simulation of carbon nanotube based antennas.					
15. SUBJECT TERMS					
16. SECURITY CLASSIFICATION OF:			17. LIMITATION OF ABSTRACT	18. NUMBER OF PAGES	19a. NAME OF RESPONSIBLE PERSON
a. REPORT	b. ABSTRACT	c. THIS PAGE			
unclassified	unclassified	unclassified	Same as Report (SAR)	5	

nanotube-based structures may lead to higher efficiencies, and could lead to practical nanoradius antennas in the GHz-THz frequency range.

In this work, we will present work-in-progress simulation results and measurements on both single tubes and tube arrays, and discuss challenges in measurement and simulation of these antennas.

2. NanoRadius Wire Antennas

The radiation efficiency (power radiated divided by power input) of a typical half-wavelength dipole antenna is excellent, usually above 98% for frequencies in the microwave regime [4]-[5]. This assumes that the antenna is constructed using high-conductivity metals, and that wire radius values are in the typical (macroscopic) range. However, in the range 1 GHz to 1 THz, wavelength varies from 10^8 to 10^5 nanometers, and an electrically very short, extremely thin wire nanoscale dipole has exceedingly small radiation efficiency. For example, at 1 GHz a 200 nm long, 50 nm radius copper wire dipole antenna has radiation efficiency $\epsilon_{\text{rad}} \sim 10^{-6}$ %, and $\epsilon_{\text{rad}} \sim 10^{-2}$ % at 1 THz [5]. Even a half-wavelength dipole has very poor radiation efficiency when the radius falls below several hundred nanometers, as shown in Fig. 1.

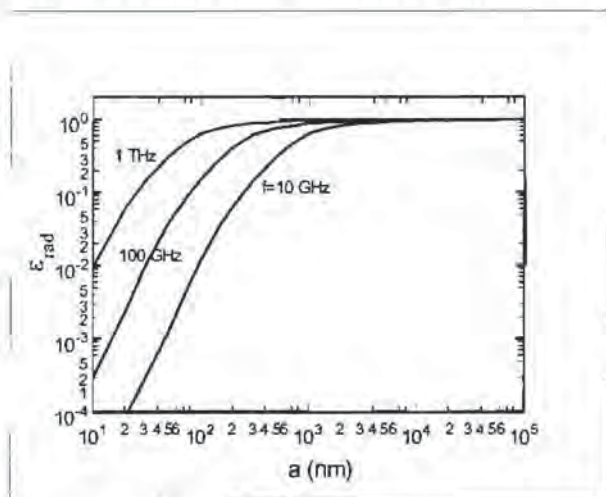

Fig. 1. Radiation efficiency for a half-wavelength copper dipole at $f=10$ GHz, 100 GHz, and 1 THz, as a function of wire radius. Reprinted from [5].

However, if the conductivity (or effective conductivity) can be increased, good radiation efficiencies can be obtained even at nanoscale radius values, as shown in Fig. 2.

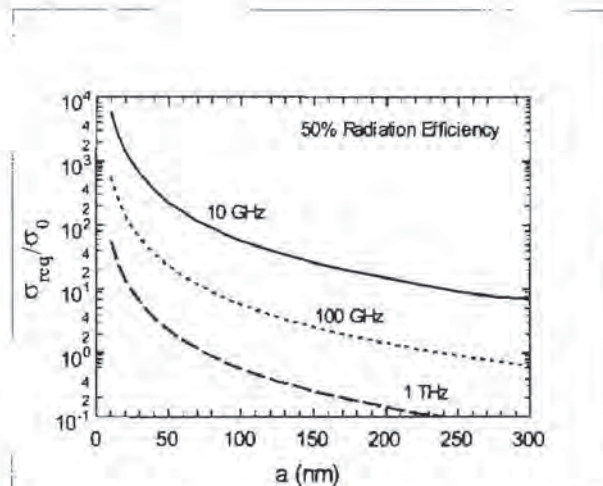

Fig. 2. Required conductivity to achieve 50% radiation efficiency for a half-wave dipole antenna as a function of radius at $f=10$ GHz. σ_0 is the bulk conductivity of copper. From [5].

The question remains as to how to achieve such high effective conductivities, and/or high radiation efficiencies for nanoscale antennas.

3. Carbon Nanotubes

Some fundamental properties of carbon nanotube antennas were discussed in [6]-[7]. Fig. 3 depicts a carbon nanotube dipole antenna, where the cross between the feed arms depicts where the tube would be cut to form a dipole.

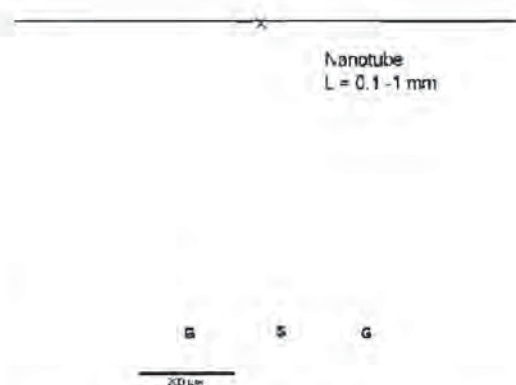

Fig. 3. Carbon nanotube dipole antenna.

The CN dipole is fed through ground-signal-ground (GSG) contact pads via a probe station. The experimental set-up is shown in Fig. 4.

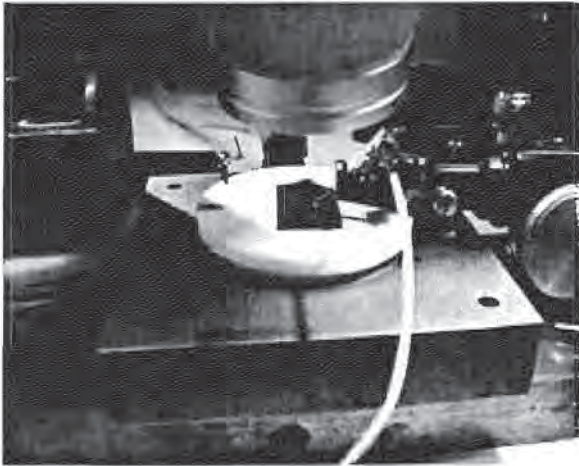

Fig. 4. Experimental set-up showing transmit dipole, carbon nanotube antenna wafer, and probe station (connected to a network analyzer acting as the receiver).

Fig. 5 shows an image of the electrodes and contact pads, with a few carbon nanotubes lying across the electrodes.

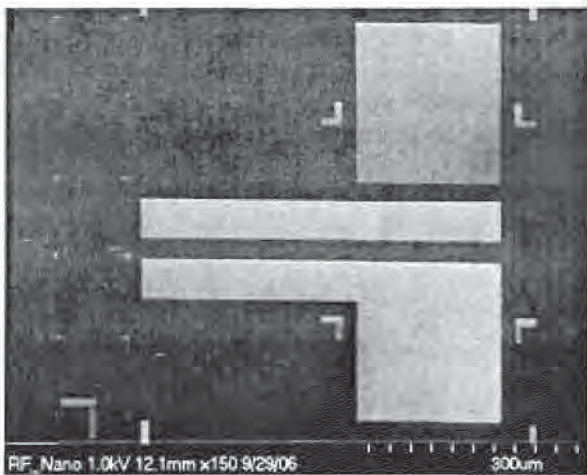

Fig. 5. Image of electrodes and GSG contact pads, and a few carbon nanotubes forming a dipole antenna.

In Fig. 6 we show the measured S_{21} between a transmit dipole and the carbon nanotube receive antenna. We see tantalizing differences between the dummy (without nanotubes) and nanotube devices. However, the low signal expected from a single nanotube antenna, and the potential influence of the metallic pads and surrounding structures evident in Fig. 4, lead us to worry that these differences are not due to the nanotube.

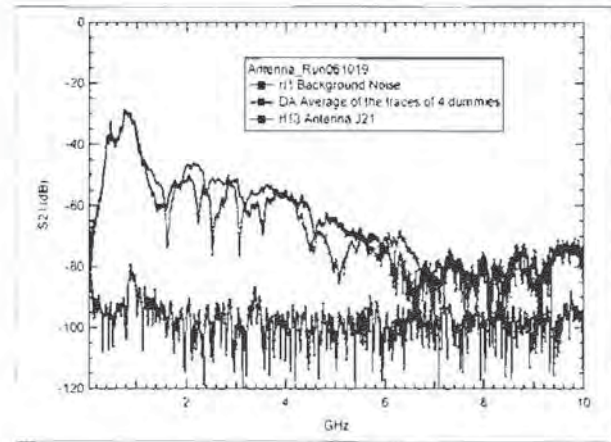

Fig. 6. Measurement of carbon nanotube antenna test structure with nanotubes and without (dummy).

This is consistent with simulation, which predicted that the response of the carbon nanotubes would be below the noise floor of the measurement. However, simulation using Ansoft HFSS of the electrode-contact pad structure (without nanotubes) did show fairly good agreement with measurement, as shown in Fig. 7. We feel that the difference between measurement and simulation at the lower frequencies is due to objects in the near field of the device (see Fig. 4), since, e.g., at 1 GHz wavelength is 30 cm, and there are clearly many metallic objects within 30 cm of the device.

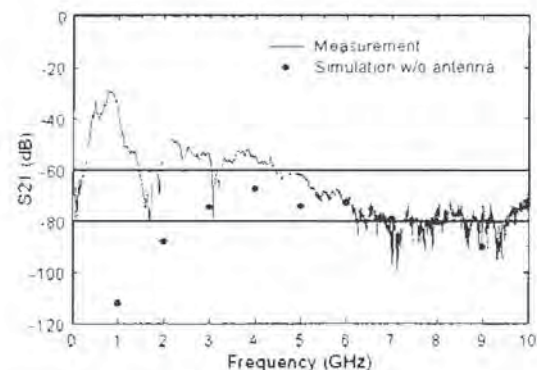

Fig. 7. Comparison between simulation and measurement for the dummy antenna structure.

Note that Fig.'s 6 and 7 show raw data (S_{21}), which is dependent on transmit-receive distance and properties of the transmit dipole, as well as properties of the device-under-test. It would be better to perform a gain measurement of the carbon nanotube antenna, but this has not been done yet.

4. Measurement and Simulation Difficulties

At this point, a brief discussion of the challenges of performing experiments and simulations of these antennas is warranted. Setting aside the obvious fabrication problems, which are beyond the scope of this paper, performing measurements at these size scales is quite difficult. Since the entire antenna structure is on the order of microns in dimensions, a probe station and microscope must be used. This introduces measurement artifacts into the results due to objects being present in the near-field, especially at lower frequencies. Furthermore, due to the low efficiencies of the antennas it is very difficult to obtain a measurable signal from the devices, since the pickup of the much larger metallic electrodes and contact pads corrupts the results.

Significant challenges are also encountered in performing simulations of nanoscale antennas. Peripheral metallic structures such as contact pads and electrodes may be on the order of several hundred microns, substrate thicknesses may be on the order of millimeters, and transmit-receive distances may be on the order of centimeters. Given the nanometer radius values of carbon nanotubes, the ratio of largest dimension to smallest dimension in the computational domain can be 10^7 or larger, and most finite-element and finite-difference codes can not perform accurate simulations at this ratio. For example, Ansoft HFSS, which is an industry-standard finite-element code, can supposedly handle ratios up to 10^6 , but we were unable to obtain reliable results even at this ratio. We have found that for carbon nanotubes it is better to use integral-equation methods, but even these are severely-taxed to accommodate the size disparities encountered in the considered devices. Simplified array geometries shown below were simulated using Wipl-d, which is a commercial thin-wire integral-equation based method.

5. Carbon Nanotube Arrays

Given the poor response of single carbon nanotube dipole antennas, it is natural to examine the performance of carbon nanotube arrays, as depicted in Fig. 8.

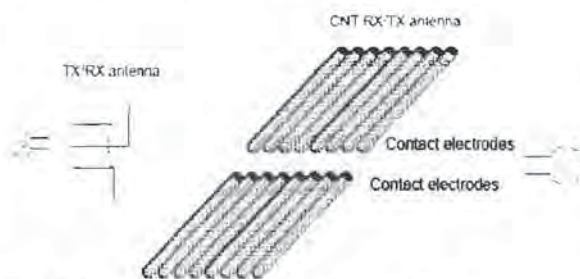

Fig. 8. A carbon nanotube array antenna.

A close up of a fabricated array structure is shown in Fig. 9, where the horizontal lines are catalyst pads for carbon nanotube growth (the nanotubes are perpendicular to the electrodes and catalyst pads).

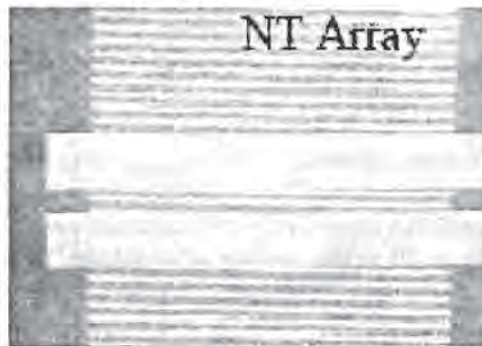

Fig. 9. Carbon nanotube array antenna.

To predict array performance, simulations were performed for a simplified structure, depicted in Fig. 10. Wire electrodes were assumed, and contact pads were ignored.

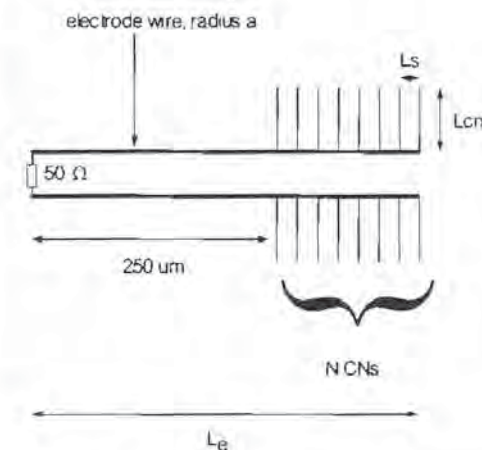

Fig. 10. Carbon nanotube antenna array geometry for simulation.

Simulation results are shown in Fig. 11 at $f=10$ GHz, predicting that as the number of nanotubes in the array increases, the response of the array to incident radiation should increase, at least for nanotubes having lengths $L=L_{cn}$ suitably large. Unfortunately, at this point only short ($L \sim 10$ μm) tube arrays have been measured, which, consistent with simulation, have not shown an increase in received signal as the number of tubes becomes large. We are currently working on increasing the length of the nanotubes in the array.

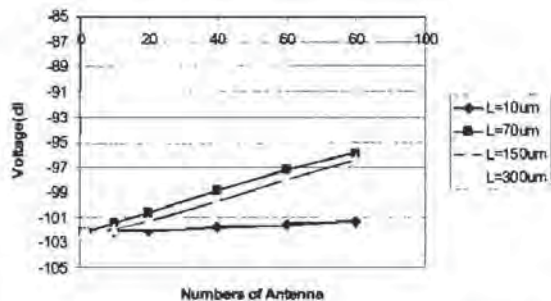

Fig. 11. Simulation results at $f=10$ GHz showing received voltage in dB as the number of nanotubes in an array is increased. L is the length of the nanotubes.

6. Summary

Communication with nanoscale circuits and devices is an important emerging antenna application. Carbon nanotubes are one possible method of fabricating nanoscale antennas. However, single nanotubes exhibit extremely low radiation efficiencies. High density carbon nanotube arrays may offer improved efficiencies, although research is still at an early stage.

7. REFERENCES

- [1] R. Saito, G. Dresselhaus, and M.S. Dresselhaus, *Physical Properties of Carbon Nanotubes*, Imperial College Press: London, 2003.
- [2] J.J. Plombon, K.P. O'Brien, F. Gstrein, and V.M. Dubin, High-frequency electrical properties of individual and bundled carbon nanotubes, *Appl. Phys. Lett.* V. 90, pp. 063106 (1-3), 2007.
- [3] Z. Yu, and P. J. Burke, Microwave transport in metallic single-walled carbon nanotubes, *Nano Letters*, v. 5, pp. 1403-1406, 2005.
- [4] W.L. Stutzman, and G.A. Thiele, *Antenna Theory and Design*, 2nd Edition, John Wiley & Sons, New York, 1998.
- [5] G.W. Hanson, Radiation Efficiency of Nanoradius Dipole Antennas in the Microwave and Far-Infrared Regime, *IEEE Antennas Propagat Magazine*, v. 50, no. 3, June 2008.
- [6] G.W. Hanson, Fundamental Transmitting Properties of Carbon Nanotube Antennas, *IEEE Trans. Antennas Propagat.*, v. 53, pp. 3426-3435, Nov. 2005.
- [7] P. J. Burke, S. Li, and Z. Yu, Quantitative theory of nanowire and nanotube antenna performance, *IEEE Trans. Nanotechnol.*, v. 5, pp 314-334, 2006.

8. ACKNOWLEDGMENTS

The authors wish to thank Dr. Dwight Woolard, U.S. Army Research Office, for his support, and the support of the Air Force Research Laboratory SBIR program.