



**NAVAL
POSTGRADUATE
SCHOOL**

MONTEREY, CALIFORNIA

THESIS

**DIGITAL SEMAPHORE: TECHNICAL FEASIBILITY OF
QR CODE OPTICAL SIGNALING FOR FLEET
COMMUNICATIONS**

by

Andrew R. Lucas

June 2013

Thesis Advisor:
Second Readers:

Don Brutzman
Ray Buettner
Jeff Weekley

Approved for public release; distribution is unlimited

THIS PAGE INTENTIONALLY LEFT BLANK

REPORT DOCUMENTATION PAGE			<i>Form Approved OMB No. 0704-0188</i>
Public reporting burden for this collection of information is estimated to average 1 hour per response, including the time for reviewing instruction, searching existing data sources, gathering and maintaining the data needed, and completing and reviewing the collection of information. Send comments regarding this burden estimate or any other aspect of this collection of information, including suggestions for reducing this burden, to Washington headquarters Services, Directorate for Information Operations and Reports, 1215 Jefferson Davis Highway, Suite 1204, Arlington, VA 22202-4302, and to the Office of Management and Budget, Paperwork Reduction Project (0704-0188) Washington, DC 20503.			
1. AGENCY USE ONLY (Leave blank)	2. REPORT DATE June 2013	3. REPORT TYPE AND DATES COVERED Master's Thesis	
4. TITLE AND SUBTITLE DIGITAL SEMAPHORE: TECHNICAL FEASIBILITY OF QR CODE OPTICAL SIGNALING FOR FLEET COMMUNICATIONS		5. FUNDING NUMBERS	
6. AUTHOR Andrew R. Lucas			
7. PERFORMING ORGANIZATION NAME(S) AND ADDRESS(ES) Naval Postgraduate School Monterey, CA 93943-5000		8. PERFORMING ORGANIZATION REPORT NUMBER	
9. SPONSORING /MONITORING AGENCY NAME(S) AND ADDRESS(ES) N/A		10. SPONSORING/MONITORING AGENCY REPORT NUMBER	
11. SUPPLEMENTARY NOTES The views expressed in this thesis are those of the author and do not reflect the official policy or position of the Department of Defense or the U.S. Government. IRB Protocol Number NPS.2011.0071-AMDI-EP7			
12a. DISTRIBUTION / AVAILABILITY STATEMENT Approved for public release; distribution is unlimited		12b. DISTRIBUTION CODE A	
13. ABSTRACT In recent decades, optical LOS communications such as flag semaphore or flashing light have atrophied to the point where, if they are required, U.S. Naval forces are at a distinct disadvantage. RF communications have become critical to nearly all operations, but this capability comes at the cost of disclosing the location of operations. Depending on the platform, these RF communications can become a critical vulnerability. EMCON attempts to minimize this vulnerability through the elimination of any RF emissions from a ship, but communication requirements in recent years have essentially prevented a complete suppression of RF emissions. This work proposes mitigating emissions vulnerability by utilizing a new method of optical communications at LOS visual ranges reminiscent of flag semaphore. Tactical QR code communications streaming digital data through optical signaling has the potential to provide tactical communications at a moderate range, allowing critical communications to be relayed to and from off-ship platforms. Additional technological advances can be used to overcome current range, security, reliability, and throughput barriers. This project demonstrates how a combination of essential technical capabilities can be used to establish a QR code communications system as a potentially useful approach for tactical operations.			
14. SUBJECT TERMS QR, barcode, 2D, adaptive optics, optical communication, EMCON, LOS, data stream, semaphore, flashing light, obfuscation, steganography.			15. NUMBER OF PAGES 157
			16. PRICE CODE
17. SECURITY CLASSIFICATION OF REPORT Unclassified	18. SECURITY CLASSIFICATION OF THIS PAGE Unclassified	19. SECURITY CLASSIFICATION OF ABSTRACT Unclassified	20. LIMITATION OF ABSTRACT UU

THIS PAGE INTENTIONALLY LEFT BLANK

Approved for public release; distribution is unlimited

**DIGITAL SEMAPHORE: TECHNICAL FEASIBILITY OF QR CODE OPTICAL
SIGNALING FOR FLEET COMMUNICATIONS**

Andrew R. Lucas
Lieutenant Commander, United States Navy
B.S., North Carolina State University, 2001

Submitted in partial fulfillment of the
requirements for the degree of

**MASTER OF SCIENCE IN SYSTEMS TECHNOLOGY
(COMMAND, CONTROL & COMMUNICATIONS)**

from the

**NAVAL POSTGRADUATE SCHOOL
June 2013**

Author: Andrew R. Lucas

Approved by: Don Brutzman
Thesis Advisor

Ray Buettner
Second Reader

Jeff Weekley
Second reader

Dan Boger
Chair, Department of Information Sciences

THIS PAGE INTENTIONALLY LEFT BLANK

ABSTRACT

In recent decades, optical LOS communications such as flag semaphore or flashing light have atrophied to the point where, if they are required, U.S. Naval forces are at a distinct disadvantage. RF communications have become critical to nearly all operations, but this capability comes at the cost of disclosing the location of operations. Depending on the platform, these RF communications can become a critical vulnerability. EMCON attempts to minimize this vulnerability through the elimination of any RF emissions from a ship, but communication requirements in recent years have essentially prevented a complete suppression of RF emissions.

This work proposes mitigating emissions vulnerability by utilizing a new method of optical communications at LOS visual ranges reminiscent of flag semaphore. Tactical QR code communications streaming digital data through optical signaling has the potential to provide tactical communications at a moderate range, allowing critical communications to be relayed to and from off-ship platforms. Additional technological advances can be used to overcome current range, security, reliability, and throughput barriers. This project demonstrates how a combination of essential technical capabilities can be used to establish a QR code communications system as a potentially useful approach for tactical operations.

THIS PAGE INTENTIONALLY LEFT BLANK

TABLE OF CONTENTS

I.	INTRODUCTION.....	1
	A. PROBLEM STATEMENT	1
	B. SOLUTION OVERVIEW.....	1
	C. MOTIVATION AND PURPOSE	2
	D. BENEFITS OF STUDY.....	3
	E. HYPOTHESIS.....	4
	F. THESIS ORGANIZATION.....	4
II.	BACKGROUND AND RELATED WORK.....	7
	A. OVERVIEW.....	7
	B. ENHANCING THE RECOGNITION RATE OF TWO-DIMENSIONAL BARCODE IMAGES AND APPLICATIONS	7
	C. IMAGING CONSIDERATIONS	8
	1. Digital Imaging Devices.....	8
	2. Adaptive Optics.....	12
III.	PROBLEM DESCRIPTION	13
	A. LOS COMMUNICATIONS OVERVIEW.....	13
	1. HF.....	13
	2. VHF.....	14
	3. UHF.....	14
	4. Flag Communications.....	14
	5. Flashing Light.....	15
	6. Other Methods	16
	B. QR SIGNALING DATAFLOW.....	17
	1. End-to-end Technology Blocks	19
	<i>a. Data Input</i>	<i>20</i>
	<i>b. Message Encoding</i>	<i>20</i>
	<i>c. Message Segmenting.....</i>	<i>20</i>
	<i>d. QR Code Images.....</i>	<i>21</i>
	<i>e. Image Display.....</i>	<i>21</i>
	<i>f. Line of Sight (LOS).....</i>	<i>23</i>
	<i>g. Image Capture.....</i>	<i>24</i>
	<i>h. Image Processing.....</i>	<i>25</i>
	<i>i. Message Decoding.....</i>	<i>25</i>
	<i>j. Data Output.....</i>	<i>26</i>
	C. RESEARCH QUESTIONS.....	26
	D. SCOPE OF RESEARCH	26
	E. CHAPTER SUMMARY.....	27
IV.	ONE-DIMENSIONAL (1D) BAR CODES, TWO-DIMENSIONAL (2D) BAR CODES, AND QR CODES.....	29
	A. CHAPTER OVERVIEW	29
	B. HISTORY OF BAR CODES AND QR CODES.....	29

C.	CHARACTERISTICS AND GENERATION OF QR CODES	30
D.	READING QR CODES.....	34
1.	Mobile Devices.....	34
2.	Specialized Cameras	34
3.	Software Implementations	34
E.	QR CODE SECURITY CONSIDERATIONS.....	35
1.	General-Purpose Data Channel.....	35
2.	Encryption	36
3.	Camouflage.....	36
4.	Obfuscation.....	36
5.	Steganography.....	37
6.	Vulnerabilities	38
F.	QR CODES FOR TACTICAL COMMUNICATIONS	38
1.	Advantages.....	38
2.	Disadvantages.....	39
G.	CHAPTER SUMMARY.....	41
V.	RESEARCH METHODS.....	43
A.	CHAPTER OVERVIEW	43
B.	SIMULATION	43
1.	Baseline Distance Simulation	43
2.	Angle Simulation.....	45
3.	Image Preparation	47
C.	FIELD EXPERIMENTATION	49
1.	Range Determination.....	50
2.	Satellite Capability Demonstration	53
3.	Limited Camp Roberts UAV Test.....	57
D.	CHAPTER SUMMARY.....	60
VI.	EXPERIMENTAL RESULTS AND ANALYSIS.....	61
A.	CHAPTER OVERVIEW	61
1.	Maximum Range Capabilities	61
2.	Equipment Variances	61
3.	Result Categories	61
4.	Analysis Tools.....	62
B.	ANALYSIS METHODS.....	62
C.	SIMULATION RESULTS.....	63
1.	Distance Simulation	63
2.	Angle Simulation.....	68
D.	FIELD EXPERIMENT (FX) RESULTS.....	69
1.	Range Determination.....	69
2.	Aircraft and Satellite Demonstration.....	71
3.	UAV Testing	73
E.	RESULTS ANALYSIS.....	73
1.	Simulation Analysis	73
2.	Field Experiment Validation.....	75
3.	Minimum QR Code Sizes	77

4.	QR Code Reconstruction.....	80
F.	QUALITATIVE RESULTS.....	82
G.	CHAPTER SUMMARY.....	83
VII.	CONCLUSIONS AND RECOMMENDATIONS.....	85
A.	FINDINGS AND CONCLUSIONS.....	85
B.	RECOMMENDATIONS FOR FUTURE WORK.....	86
1.	Simulation and Testing.....	86
a.	<i>Angle Validation</i>	86
b.	<i>Realistic Environment Testing</i>	86
c.	<i>Aircraft QR Code Detection</i>	87
d.	<i>Streaming QR Code Communication</i>	88
2.	Software	88
a.	<i>QR Code Detection Capabilities</i>	88
b.	<i>Metadata and Cataloging</i>	89
c.	<i>Software Interface Development</i>	89
3.	Technology.....	89
4.	Security	89
	APPENDIX A—QR CODE WIKIPEDIA.....	91
	APPENDIX B—KEY EQUIPMENT SPECIFICATIONS.....	105
A.	IPHONE 4S 8 MEGAPIXEL CAMERA	105
B.	CANON POWERSHOT SD880 IS 10 MEGAPIXEL CAMERA	106
C.	CANON EOS 5D MARK II.....	107
D.	JVC GY-HD200 720P VIDEO CAMERA	108
E.	JVC GY-HM750 1080P VIDEO CAMERA	109
F.	DIGITALGLOBE WORLDVIEW-1	110
G.	DIGITALGLOBE WORLDVIEW-2.....	111
H.	INSTANTEYE STANDARD CAMERA, SHENZHEN 520TVL.....	112
I.	INSTANTEYE FLIR CAMERA, QUARK 336	113
J.	CANON DC420	113
K.	GOPRO HERO3 BLACK.....	114
L.	ASTRO DESIGN 4K CAMERA SYSTEM, AH-4413.....	115
	APPENDIX C—EXPERIMENT SCHEDULE OF EVENTS	117
A.	BASELINE DISTANCE SIMULATION	117
B.	BASELINE DISTANCE VALIDATION EXPERIMENT	117
C.	BASELINE ANGULAR SIMULATION.....	117
D.	BASELINE ANGULAR VALIDATION EXPERIMENT	117
E.	PROBABILITY OF DETECTION SIMULATION.....	117
F.	PROBABILITY OF DETECTION VALIDATION EXPERIMENT	118
G.	AIRCRAFT/UAV QR CODE DETECTION	118
H.	SATELLITE IMAGERY QR PIXEL AND QR CODE DETECTION..	118
I.	USV TWO-WAY QR CODE DETECTION	118
	APPENDIX D—SIMULATION AND EXPERIMENT DATA.....	119
	LIST OF REFERENCES	125

INITIAL DISTRIBUTION LIST127

LIST OF FIGURES

Figure 1.	High-level operational concept graphic for the tactical employment of optical LOS communications methods including QR codes (From Richter, 2013).	2
Figure 2.	Image processing flowchart for the detection and decoding of a QR code (After Liao et al., 2011).	8
Figure 3.	Generic block diagram showing the functions of a solid state camera (From Holst, 1998).....	10
Figure 4.	Categories of noise introduced from image sensor array subsections (From Holst, 1998).....	11
Figure 5.	Ideal dataflow for a tactical QR code communications system considering end-to-end technology factors (From Digital Semaphore, 2012).	19
Figure 6.	Side by side comparison of commonly used 2D barcodes, to include matrix and stacked bar code styles.....	30
Figure 7.	General characteristics of a 2D QR code compared to a 1D traditional barcode (From Sutheebanjard & Premchaiswad, 2010).	31
Figure 8.	Key structural features of a QR code symbol (From International Organization of Standards, 2006, September 01).	31
Figure 9.	Comparison of version 1 and 2 QR code symbols (From International Organization of Standards, 2006, September 01).	32
Figure 10.	Characteristics of a version 14 QR code symbol (From International Organization of Standards, 2006, September 01).	32
Figure 11.	An artist’s rendering of a QR code reading, “http://qr.nps.edu” with the traditional finder patterns replaced by alternate patterns.	36
Figure 12.	As an example of obfuscation, a valid QR code reading, “http://qr.nps.edu” is placed within a complex background. Note that in this image, the required white quiet zone surrounding the valid QR code is not present, but can be regenerated based on the reference points provided by the finder patterns.	37
Figure 13.	Capturing a digitally displayed 35% QR code image during simulation.....	44
Figure 14.	Capturing a print displayed 80% QR code image during simulation.	45
Figure 15.	Capturing a digitally displayed 56 degree off-perpendicular QR code image during simulation.	46
Figure 16.	Capturing a print displayed 80 degree off-perpendicular QR code image during simulation.	46
Figure 17.	X3D image simulation tool displaying “http://qr.nps.edu” at an angle of 36 degrees from a perpendicular viewpoint.	47
Figure 18.	Test QR code image: “From technical to tactical.” Version 2, ECC L (7%), 25 x 25 QR bits. Note the necessary standards-compliant inclusion of the quiet zone 4 QR bits wide.....	48
Figure 19.	Field testing QR display stand constructed of basic lumber and plywood. Test QR code image: “From technical to tactical.” Version 2, ECC L(7%), 25 x 25 QR bits, 37.5 inches x 37.5 inches.	50

Figure 20.	NPS LOS Location: 215 yards available between the Hermann Hall circle and the main gate (After http://maps.google.com).	51
Figure 21.	Test Image Placement at NPS in the Spruance courtyard next to Spanagel Hall facing the Hermann Hall Circle.	51
Figure 22.	Fort Ord LOS Location: 650 yards available diagonally across the asphalt lot at the motor pool (After http://maps.google.com).	52
Figure 23.	Test image placement at the Northwest corner of the motor pool lot at Fort Ord.	53
Figure 24.	Bushnell Elite 1600 ARC laser range finder used for distance determination during all field testing. Capable of determining distances of 6 to 1600 yards. (From http://www.bushnell.com).	53
Figure 25.	Complete view of King Hall QR code from atop Spanagel Hall.....	54
Figure 26.	Conceptual aerial View of King Hall QR Code using commercial open-source overhead imagery (After http://maps.google.com).	55
Figure 27.	Aerial view of King Hall QR code using commercial overhead imagery captured from DigitalGlobe Worldview-1 dated 14 April, 2013.....	55
Figure 28.	Safety setup at the work area entry point atop King Hall.	56
Figure 29.	Safety setup atop King Hall showing the complete work area including visual safety barriers and entry point.	57
Figure 30.	PSI Corp. InstantEye quad rotor UAV.	58
Figure 31.	InstantEye HD video capture of the test QR image on the runway at McMillan Field, Camp Roberts.	58
Figure 32.	InstantEye LWIR video capture of the test QR image on the runway at McMillan Field, Camp Roberts.	59
Figure 33.	Artist’s depiction of potential QR code locations at McMillan airfield using commercial open-source overhead imagery (After http://maps.google.com).	59
Figure 34.	Range extrapolation of simulation data from still image cameras captured from a digitally displayed QR code.	64
Figure 35.	Range extrapolation of simulation data from video cameras captured from a digitally displayed QR code.	64
Figure 36.	Range extrapolation of simulation data from still image cameras captured from a print displayed QR code.	65
Figure 37.	Range extrapolation of simulation data from video cameras captured from a print displayed QR code.	65
Figure 38.	Range extrapolation of simulation data from still image cameras captured from both digital and print displayed QR codes.	66
Figure 39.	Range extrapolation of simulation data from video cameras captured from both digital and print displayed QR codes.	66
Figure 40.	Range extrapolation of simulation data from both still image and video cameras captured from a digitally displayed QR code.	67
Figure 41.	Range extrapolation of simulation data from both still image and video cameras captured from both a print and digitally displayed QR code.	67
Figure 42.	Maximum ranges of successfully read QR codes from images captured from still image cameras.	69

Figure 43.	Maximum ranges of successfully read QR codes from images captured from video cameras.....	70
Figure 44.	Maximum ranges of successfully read QR codes from images captured from both still image and video cameras.....	70
Figure 45.	Process steps showing the iterative improvements of a raw captured image resulting in a readable QR code.....	71
Figure 46.	WorldView-1 satellite demonstration imagery (0.5 meter pixel resolution). Not readable.....	72
Figure 47.	WorldView-2 satellite demonstration imagery (0.46 meter pixel resolution). Not readable.....	72
Figure 48.	Extrapolation curves from still image camera simulation.....	73
Figure 49.	Extrapolation curves from video camera simulation.....	74
Figure 50.	Extrapolation curves from still image and video camera simulations.....	74
Figure 51.	Maximum ranges of successfully read QR codes from images captured from still image cameras superimposed on expected ranges extrapolated from simulation data.....	76
Figure 52.	Maximum ranges of successfully read QR codes from images captured from video cameras superimposed on expected ranges extrapolated from simulation data.....	76
Figure 53.	Maximum ranges of successfully read QR codes from images captured from both still image and video cameras superimposed on expected ranges extrapolated from simulation data.....	77
Figure 54.	Statistical distribution of QR bit size data from primary evaluation of simulated data ranges.....	78
Figure 55.	Statistical distribution of QR bit size data from secondary evaluation of simulated range images.....	78
Figure 56.	Statistical distribution of QR bit size data from primary evaluation of experimental range images.....	79
Figure 57.	Statistical evaluation of QR bit size data from secondary evaluation of experimental range images.....	80
Figure 58.	Demonstration of single QR bit reconstruction using 4K video camera image of a 100 inch x 100 inch QR code captured at 750 yards.....	81
Figure 59.	Apple iPhone 4S with 8 Megapixel Digital Camera (From http://www.apple.com).....	105
Figure 60.	Canon PowerShot SD880 IS Digital Camera (From http://www.canon.com).....	106
Figure 61.	Canon EOS 5D Mark II DSLR Camera (From http://www.canon.com).....	107
Figure 62.	JVC GY-HD200 720P HD Video Camera (From http://www.jvc.com).....	108
Figure 63.	JVC GY-HM750 1080P HD Video Camera (From http://www.jvc.com).....	109
Figure 64.	WorldView-1 with BHRC 60 Imager (From http://www.janes.com).....	110
Figure 65.	WorldView-2 with WorldView 110 Imager (From http://www.janes.com).....	111
Figure 66.	Shenzhen 520TVL Video Camera (From http://www.alibaba.com).....	112
Figure 67.	Quark 336 LWIR Camera (From http://www.flir.com).....	113
Figure 68.	Canon DC420 Digital Camcorder (From http://www.canon.com).....	113
Figure 69.	GoPro Hero3 Black 4K Video Camera (From http://www.gopro.com).....	114

Figure 70. Astro AH-4413 4K Camera Head (From <http://www.astrodesign.co.jp>).115

LIST OF TABLES

Table 1.	QR code error correcting capability levels (After Sutheebanjard & Premchaiswad, 2010).....	33
Table 2.	QR code capacity (After International Organization of Standards, 2006, September 01).	33
Table 3.	Imaging equipment characteristics for simulation and field experimentation.....	44
Table 4.	Test QR code image parameters.	47
Table 5.	Maximum distances, in yards, at which a QR code was successfully captured and decoded for each camera.	61
Table 6.	Range extrapolation from simulation.....	63
Table 7.	Maximum off-perpendicular angles of successfully read QR images.	68
Table 8.	Field experiment maximum range results.	69
Table 9.	Simulation prediction equations.	75
Table 10.	QR bit size, in pixels, from the smallest readable QR code images digitally displayed.	77
Table 11.	QR bit size, in pixels, from the smallest readable QR code images print displayed.	78
Table 12.	QR bit size, in pixels, from highest-range readable QR code images	79
Table 13.	Simulation and Field Experiment Results Legend.....	119
Table 14.	Digital Display Simulation Data.....	120
Table 15.	Printed Display Simulation Data	121
Table 16.	Still Image Camera Field Experiment Data	122
Table 17.	Video Camera Field Experiment Data.....	123

THIS PAGE INTENTIONALLY LEFT BLANK

LIST OF ACRONYMS AND ABBREVIATIONS

2D	Two Dimensional
AIM	Association for Automatic Identification and Mobility (http://www.aimglobal.org)
ARSENL	Advanced Robotic Systems Engineering Laboratory
C4ISR	Command, Control, Communications, Computers, Intelligence, Surveillance, and Reconnaissance
CCD	Charge-Coupled Device
CCF	Camera Capability Factor
CID	Charge-Injection Device
CMOS	Complementary Metal Oxide Semiconductor
COTS	Commercial off the Shelf
CRUSER	Consortium for Robotics and Unmanned Systems Education and Research (http://www.nps.edu/research/cruser)
DPI	Dots per Inch
DR	Dynamic Range
ECC	Error-Correcting Code
EM	Electromagnetic
EM ²	Electromagnetic Maneuver
EMCON	Emissions Control
FEC	Forward Error Correction
FOV	Field of View
FPGA	Field Programmable Gate Array
FPS	Frames per Second
HERO	Hazards of Electromagnetic Radiation to Ordnance

HD	High Definition
HF	High Frequency
IPR	Intellectual Property Rights
ISO	International Organization for Standards (http://www.iso.org)
JIS	Japanese Industrial Standard
JPEG	Joint Photographic Experts Group (digital image format; http://www.jpeg.org)
LED	Light Emitting Diode
LOS	Line of Sight
LPD	Low Probability of Detection
LPE	Low Probability of Exploitation
LPI	Low Probability of Intercept
LWIR	Long-Wave Infrared
MMOWGLI	Massive Multiplayer Online War Game Leveraging the Internet (http://mmowgli.nps.edu)
MOVES	Modeling, Virtual Environments and Simulation (http://www.movesinstitute.org)
MP	Megapixel
NEE	Noise Equivalent Exposure
OS X	Operating System X
PNG	Portable Network Graphics (digital image format)
QR	Quick Reaction
RGB	Red Green Blue
RF	Radio Frequency
RMS	Root Mean Square
SEE	Saturation Equivalent Exposure

SNR	Signal-to-Noise Ratio
TCP/IP	Transmission Control Protocol/Internet Protocol
TDA	Tactical Decision Aid
UAV	Unmanned Aerial Vehicle
UHF	Ultra High Frequency
URL	Uniform Resource Locator
VHF	Very High Frequency
WIW	Warfare Innovation Workshop
X3D	Extensible 3D (graphics international standard)

THIS PAGE INTENTIONALLY LEFT BLANK

GLOSSARY

1/f Noise. Also known as pink noise or flicker noise; noise containing a mixture of frequencies, but excluding higher frequencies.

Adaptive Optics. The use of technology to improve the performance of optical systems by compensating for wave front distortions caused by atmospheric turbulence.

Alignment Pattern. Fixed reference pattern in defined positions in a matrix symbology, which enables the decode software to re-synchronize the coordinate mapping of the image modules in the event of moderate amounts of linear and non-linear optical distortion of the image.

Anti-Access/Area Denial (A2AD). Enemy actions which inhibit military movement into a theater of operations, and activities that seek to deny freedom of action within areas under the enemy's control.

Anti-Aliasing. The software process for removing or reducing the jagged distortions in curves and diagonal lines so that the lines appear smooth or smoother

Charge-Coupled Device (CCD). A charge-transfer device used as an image sensor in which the image-representing electrical charge is moved, usually from within the device to an area where the charge can be manipulated.

Charge-Injection Device (CID). A charge-transfer device used as an image sensor in which the image points are accessed by reference to their horizontal and vertical coordinates.

CMOS image sensor. An image sensor consisting of an integrated circuit containing an array of pixel sensors, each pixel containing a photodetector and an active amplifier capable of on-chip processing.

De-Bayering. The use of a 50% green, 25% red and 25% blue pattern to reconstruct image sensor data into a viewable, color image.

Dynamic Range (DR). The ratio between the largest (maximum signal) and smallest (RMS noise) possible values of a changeable quantity, such as in signals like sound and light.

Emissions Control (EMCON). The control of all electromagnetic and acoustic radiations, including communications, radar, EW and sonar with the intent of safeguarding essential elements of friendly information. During its imposition, no electronic emitting device within designated bands, including personal communication devices, will be operated unless absolutely essential to the mission.

Encryption. A process to ensure data or information is read or used only by its intended readers or users and denied to all unauthorized entities.

Error-Correcting Code (ECC). A method of inserting redundant information prior to digital storage, recording or transmission, and processing that information upon subsequent playback or reception, so that recording or transmission errors can be detected (and in some cases, perfectly corrected).

Field Programmable Gate Array (FPGA). An integrated circuit designed to be configured by a customer or a designer after manufacturing.

Finder Pattern. The three identical Position Detection Patterns located at the upper left, upper right and lower left corners of the symbol respectively. They are preferentially encoded so that similar patterns have a low probability of being encountered elsewhere in the symbol and enable the rapid identification of a possible QR Code symbols in the field of view. They also unambiguously define the precise location and orientation of the symbol.

Focal Length. The distance in millimeters from the optical center of a lens to the imaging sensor when the lens is focused at infinity.

Forward Error Correction (FEC). A technique for controlling errors in transmitted data. The use of redundant error-correcting codes for FEC allows a limited number of errors to be corrected without retransmission (Hamming, 1950).

f-stop. The ratio of the lens's focal length to the diameter of the entrance pupil which determines how much light is allowed to enter through the lens aperture to the image sensor.

Hazards of Electromagnetic Radiation to Ordnance (HERO). The program concerned with prevention of accidental ignition of electrically initiated devices in ordnance due to RF electromagnetic fields.

Interlaced Scan. A scanning standard in which alternate raster lines of a frame are displaced vertically by half the scan-line pitch and displaced temporally by half the frame time to form a first field and a second field.

Line of Sight (LOS). A direct propagation path that does not go below the radio horizon.

Long Wave Infrared (LWIR). electromagnetic radiation with longer wavelengths than those of visible light, extending from the nominal red edge of the visible spectrum at 0.74 μm to the border of the microwave region at 0.3 mm.

Low Probability of Detection (LPD). Pertaining to a signal that minimizes the probability that its presence can be detected by an unauthorized party. The result of measures put in place to disguise or hide intentional electromagnetic transmissions.

Low Probability of Exploitation (LPE). Preventing the exploitation of a signal by denying the adversary knowledge of the system, its modulation characteristics, its use and its users.

Low Probability of Intercept (LPI). Pertaining to a signal that minimizes the probability that the intelligence contained in the signal can be intercepted by an unauthorized party.

Noise Equivalent Exposure (NEE). The input signal that produces a sensor signal-to-noise ratio of one; minimum signal.

Obfuscation. The hiding of intended meaning in communication, making communication confusing, willfully ambiguous, and harder to interpret.

Pixel. The smallest unit of a video display screen image.

Progressive Scan. The capture of all pixels of an image simultaneously. A scanning standard in which spatially adjacent picture lines are associated with consecutive periodic (or identical) instants in time.

QR Bit. The smallest structure within a QR code representing a one (black) or zero (white).

QR Code. A two dimensional barcode developed by the Denso Wave corporation in the 1990s for the Japanese automotive manufacturing industry. See Appendix A for full details.

Reed-Solomon Error Correction. An error-correcting code that oversamples a polynomial constructed from the data and the polynomial is evaluated at several different points. This oversampling causes the polynomial to be over-determined, which allows the receiver to recover the original polynomial with enough points received correctly. Each input symbol is from a set of size greater than 2 to enable a receiver to recover the k source symbols from any set of k received symbols.

Resolution. 1. Generally, a measure of the ability to delineate picture detail. 2. In computing, the count of columns and rows of pixels in a device or in an image.

Red Green Blue (RGB) Color Model. An additive color model in which red, green, and blue tristimulus components (linear-light) are added together in various ways to reproduce a broad array of colors.

Saturation Equivalent Exposure. The input level that produces full sensor charge wells; maximum signal.

Semaphore Signaling. Visual signaling in which the positions of the hands each holding a flag are used to represent letters of the alphabet, numerals, punctuation, and certain procedure words and prosigns that are used for the transmission of messages.

Signal-to-Noise Ratio (SNR/ $E_B N_0$). A measure used in science and engineering that compares the level of a desired signal to the level of background noise. It is defined as the ratio of signal power to the noise power in which a ratio higher than 1:1 indicates more signal than noise.

Steganography. The art or practice of concealing a message, image, or file within another message, image, or file

Transmission Control Protocol/Internet Protocol (TCP/IP). A specification or software that bundles and unbundles data into packets, manages network transmission of packets, and checks for errors.

Timing Pattern. Alternating sequence of dark and light modules enabling module coordinates in the symbol to be determined.

THIS PAGE INTENTIONALLY LEFT BLANK

ACKNOWLEDGMENTS

First and foremost, I would like to thank my loving wife, Erica, for her unwavering support. Her encouragement, enthusiasm, patience, and understanding were, in no small part, integral to my successful completion of this thesis.

This thesis would not have been possible without the assistance and support of my advisors, Dr. Don Brutzman and Dr. Ray Buettner. Their expertise and encouragement made it possible for me to grow and their experience and guidance helped to ensure success when I strayed. Mr. Jeff Weekley, Mr. Mike Bailey, and Mr. Jeff Malnick spent countless hours assisting with experiments and developing processes to one day make this study a reality.

I gratefully acknowledge the initial concept generation by participants in the CRUSER 2012 Warfare Innovation Workshop. Captain (ret.) Jeff Kline, thank you for providing such a robust topic and backing the work herein to ensure it received the visibility and funding necessary to continue to fruition.

Naval Warfare Development Command (NWDC) conduct of the Electromagnetic Maneuver (EM2) wargame using the Office of Naval Research (ONR) sponsored Massive Multiplayer Online Wargame Leveraging the Internet (MMOWGLI) platform allowed expert consideration of the principles explored in this thesis.

To all of the support staff here at NPS, thank you for helping me get through the difficult paperwork and regulations that often accompany work within the government. You helped me alleviate that burden so that I could focus on my work.

Thank you to my family members from afar who have always supported me through the worst and best times of my career. Without that support, I sincerely doubt I would have achieved the success I enjoy today.

Finally, thank you Lieutenant Phil Richter for taking on this daunting project with me. You have been an invaluable partner both with contributions and helping me keep my wits about me during the most frustrating times. You have made this experience

memorable, but more importantly, I am glad to be finishing my time here at NPS with such a good friend.

I. INTRODUCTION

A. PROBLEM STATEMENT

HF, UHF, and VHF LOS communications are common throughout the world and an adversary can easily acquire equipment to intercept or disrupt naval communications. This has significant implications for communication between naval ships, naval aircraft and unmanned systems.

Further, Emissions Control (EMCON) and Hazards of Electromagnetic Radiation to Ordnance (HERO) restrict the ability for Naval Vessels to communicate using traditional radio frequency communications. Improved approaches are needed.

B. SOLUTION OVERVIEW

Line-of-sight optical communications using Quick (QR) codes is a potential solution to the vulnerabilities of Radio Frequency (RF) LOS communications. With sufficient technological support and under the right conditions, communications of this fashion may occur over significantly long distances. Figure 1 depicts a high-level view of the tactical employment of optical signaling using QR codes. The solid yellow lightning bolts represent RF communications. The dashed lines marked DFL represent digital flashing light communications, and the solid green arrows with the eyeball superimposed represent optical QR code communications. It is important to note that in an idealized situation such as this with the sole exception of signaling between high-altitude aircraft and satellites, optical communications essentially remove RF communications from the critical battlefield environment.

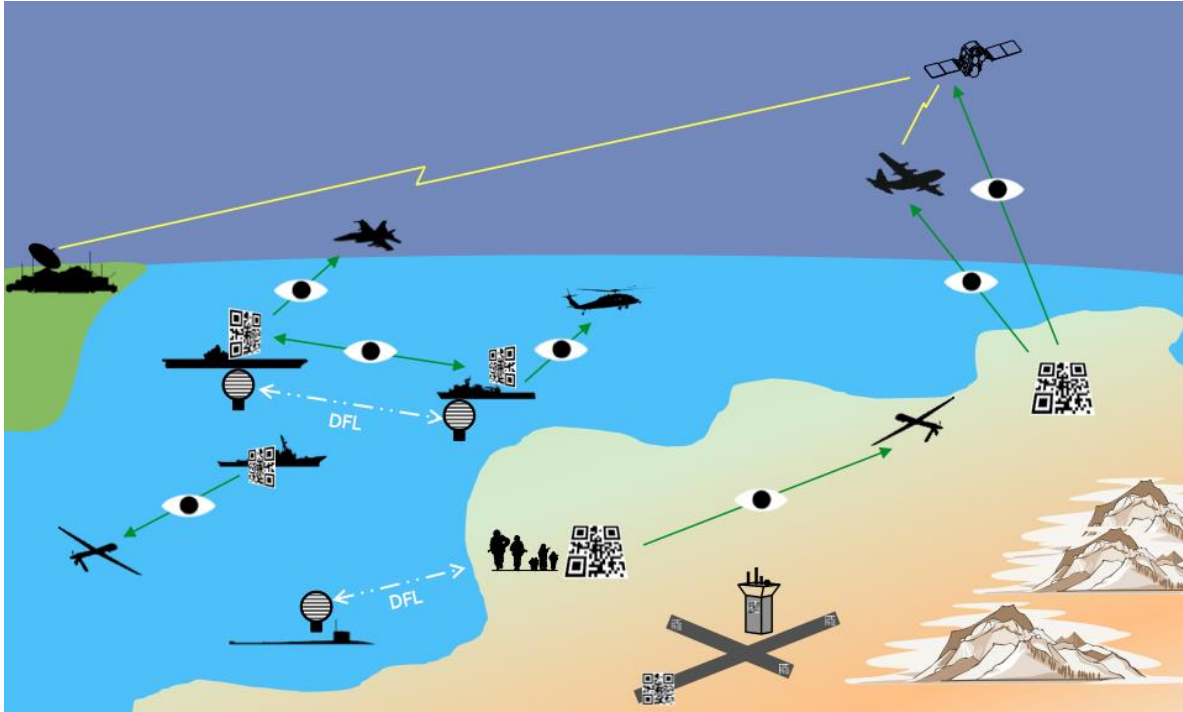

Figure 1. High-level operational concept graphic for the tactical employment of optical LOS communications methods including QR codes (From Richter, 2013).

C. MOTIVATION AND PURPOSE

Optical communication techniques for naval coordination, such as flag semaphore or blinking light, have proven beneficial in naval victories throughout history. With the advent of RF communications, most cases of visual communications have become obsolete or excessively expensive, limiting LOS tactical communications to systems vulnerable to jamming or interception. Additionally, under the most restrictive conditions limiting RF emissions, tactical communications may be non-existent without optical capabilities.

This QR code research needs to be conducted in order to ensure the future communications between tactical units are more discrete, more difficult to jam, and can be conducted in an emissions-denied environment. This type of digital communication can also allow for the military to communicate quickly and effectively as an alternative to LOS voice communications.

In an ever-constrained budgetary environment, lower-priced alternatives are often presented and selected to satisfy requirements. In the case of video technology, 720 high-definition (HD) imagery has become the standard for C4ISR collection assets. With QR code technology forming from the ground up, it should be noted that the difference in price from 720 HD resolution to current technologies such as 4K or 8K is minimal, especially when compared to the cost-savings had by eliminating upgrades in the near future. 4K and beyond are being widely adopted in commercial video production and prices continue to trend downward with broad acceptance (Digital Semaphore, 2012).

D. BENEFITS OF STUDY

The ultimate benefit of this thesis is to provide an alternative and jam-resistant form of fast and reliable optical LOS communications to the fleet that can augment the current RF communications suite. This system is able to leverage many existing commercial-off-the-shelf (COTS) technologies in the form of QR code reading and generation software. Additionally, QR-code transmissions are platform agnostic, preventing adversaries from inferring information about the source based on the characteristics of the transmission itself.

Using QR code as a form of optical communication may be vulnerable to non-permissible environments such as hazy conditions, fog, heavy seas, excessive background lighting or insufficient illumination. Unless exclusive equipment is used, any unencrypted transmissions may be vulnerable to intercept by an adversary.

This thesis will recommend the purchase of the technology required for the Naval fleet to implement digital semaphore as a reliable, jam-resistant form of communication to be used in conjunction with existing RF technologies.

This work has fundamental implications for naval warfare. Literature review to date has not revealed any industry or academic efforts that are exploring these possibilities. Patent applications have been initiated to ensure that the Navy's long-term Intellectual Property Rights (IPR) are protected.

E. HYPOTHESIS

Sufficiently advanced technologies are available to develop a tactical QR code communications system commensurate with the visual LOS capability deficit currently in the fleet.

F. THESIS ORGANIZATION

This thesis discusses the feasibility and benefits of introducing optical communications using QR codes tactically between naval units. It will discuss the infrastructure support required and the benefits gained over existing LOS communication methods.

Experiment descriptions and results will be included to establish a technology versus capability baseline. From this baseline, further experimental results discuss current capabilities based on commonly available commercial technology.

Throughout, many applications for tactical QR code communications will be discussed. For extensive study, refer to *Digital Semaphore: Tactical Implications of QR Code Optical Signaling for Fleet Communications* (Richter, 2013). This document collaboratively explored much of the research herein and shares several chapters. Specifically, Chapter IV, One-Dimensional (1D) Bar Codes, Two-Dimensional (2D) Bar Codes, and QR Codes, Chapter V, Research Methods, and Chapter VI, Experimental Results and Analysis are co-authored for both theses. Appendix A, QR Code Wikipedia, Appendix C, Experiment Schedule of Events, and Appendix D, Simulation and Experiment Data are shared as well.

The chapters and appendices of this thesis are organized as follows. Chapter I introduces the QR code communications topic and the motivation for further study. Chapter II provides a brief summary of previous work with relevant QR code communications. Chapter III discusses, in detail, the need for the development of an optical QR code communications system. Chapter IV provides a history of barcodes and an overview of QR codes. Chapter V describes the simulation and experimentation completed with this study. Chapter VI collects and analyzes the results of the aforementioned research. Chapter VII draws final conclusions and provides

recommendations for further work. Appendix A is a detailed synopsis of QR codes intended for reader familiarization. Appendix B lists the key specifications for the equipment used during simulations and experimentation. Appendix C outlines the completed schedule of simulations and experiments. Appendix D contains the complete data sets from simulation and experiment.

THIS PAGE INTENTIONALLY LEFT BLANK

II. BACKGROUND AND RELATED WORK

A. OVERVIEW

This chapter summarizes a study by the national Formosa University that discusses methods for increasing the recognition of QR codes within an image. Additionally, the supporting technology from digital imaging devices and adaptive optics are discussed.

B. ENHANCING THE RECOGNITION RATE OF TWO-DIMENSIONAL BARCODE IMAGES AND APPLICATIONS

Normally 2D barcodes are deciphered using software, but this study examines increased reliability of QR detection through the use of image matching (Liao et al., 2011).

Several previous studies were considered, all of which discussed various methods for identifying the boundaries of a QR code. One such example is the use of the Moore-Neighbor Contour Tracing Algorithm to establish the boundaries of the QR code followed by the Hough Transform (line detection technique) to extend the lines estimating the barcode region. The key consideration from this review was that if the finder patterns of a QR code are not found, the code is either not recognized or mistakenly read (Liao et al., 2011).

The focus of the article was in development of the image processing using software to recognize and process QR codes. To flow identified for image processing includes: Color Mode Conversion, Detection of the Finder pattern, Bilinear Transformation, Image-capturing, Image Ratio Transformation, and Image Matching (Liao et al., 2011).

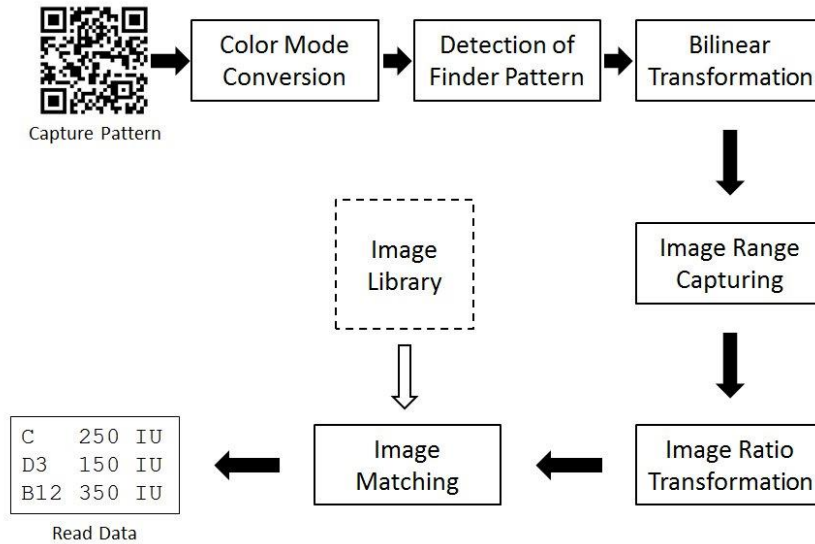

Figure 2. Image processing flowchart for the detection and decoding of a QR code (After Liao et al., 2011).

Color Mode Conversion consists of converting a RGB color image to greyscale followed by a transformation to binary for further processing. Detection of the Finder Patten occurs when the binary image is processed and the 1:1:3:1:1 ratio patterns are found to identify the finder patterns. Bilinear Transformation corrects for image rotation and distortion to provide a perfectly square QR code for further analysis. Image Range Capturing utilizes the known good positions of the finder patterns to determine the boundaries of the QR code. Image Ratio Transformation standardized the image to fixed pixel sizes for further comparison. Image Matching compares the captured QR image with catalogued images in a library to determine the data contained (Liao et al., 2011).

C. IMAGING CONSIDERATIONS

1. Digital Imaging Devices

In 1970, charge-coupled devices (CCDs) were invented by Boyle and Smith. Combined with optical systems, these devices have since revolutionized imaging systems. Modern cameras are more likely to contain charge-injection devices (CIDs) or complementary metal-oxide semiconductors (CMOS) as detectors, but because CCDs were the first solid-state detectors, the term is commonly used for all solid-state cameras (Holst, 1998).

With a CCD camera, array specifications, capabilities and limitations are the physical characteristics set during the manufacturing process that ultimately determine the capability of producing quality images. If the interpretation of image quality is performed by an observer, then that observer becomes a component of the imaging system (Holst, 1998).

With a CCD, three basic functions are performed to capture an image: charge collection, charge transfer, and the conversion of charge into a measurable voltage. Metal-oxide-semiconductor capacitors using varying gate voltages are used to store or transfer charges. In modern devices, CMOS technology allows a camera to use active pixels. This allows multiple transistors integrated into each pixel providing on-chip image processing (Holst, 1998).

For the purposes of this study, we are interested in the benefits of leveraging this technology with military applications in mind. Traditionally, the military is interested in detecting, recognizing, and identifying targets at long distances. In this case the same is true, but with QR codes as the targets. Initially, a human can determine whether a QR code is present and the minimum resolvable contrast can be used to determine if the code is readable (Holst, 1998). With the current state of modern technology, solid-state cameras of small stature and high quality and capability are readily available for military use.

In a digital camera, the optical lenses focus the visible light onto the CCD array. In some cameras, an infrared filter eliminates the visible portions of the light spectrum prior to any light reaching the CCD array. An analog-to-digital converter may provide additional on-board digital processing following the CCD array. This processing helps account for the disparity caused by the various sampling frequencies inherent with the unequal number of red, green and blue detectors in the CCD array. Gamma correction presents a linear transformation from a scene to an observer compensating for a monitor's nonlinear response. The post-reconstruction portion of the system removes the stair-step appearance from the digital-to-analog converter and creates a smooth analog signal (Holst, 1998).

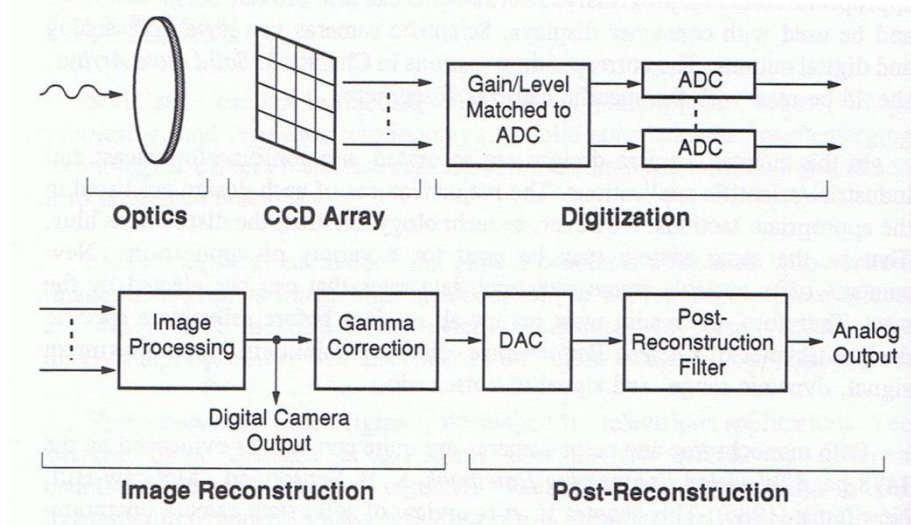

Figure 3. Generic block diagram showing the functions of a solid state camera (From Holst, 1998).

The CCD array is one of the components of an optical imaging system that can have the largest effects on its performance for the purposes of this research. The most common array performance measures are noise, charge well capacity, and responsivity. From these, the minimum signal, maximum signal, signal-to-noise ratio (SNR), and dynamic range (DR) can be calculated. Responsivity is the output as a function of the incident flux density or energy density averaged over the spectral response of the array. The minimum signal, synonymous with the Noise Equivalent Exposure (NEE), is the exposure that produces a SNR ratio of one. The maximum signal is the input signal that saturates the charge well. Also known as the Saturation Equivalent Exposure (SEE). The dynamic range is the maximum signal (peak) divided by the RMS noise ($DR=SEE/NEE$). Noise appears in a multitude of types including shot noise, reset noise, on-chip amplifier noise, off-chip amplifier noise, quantization noise, pattern noise. Although the origins of each of these noises are different, they all appear as variations in the image intensity (Holst, 1998).

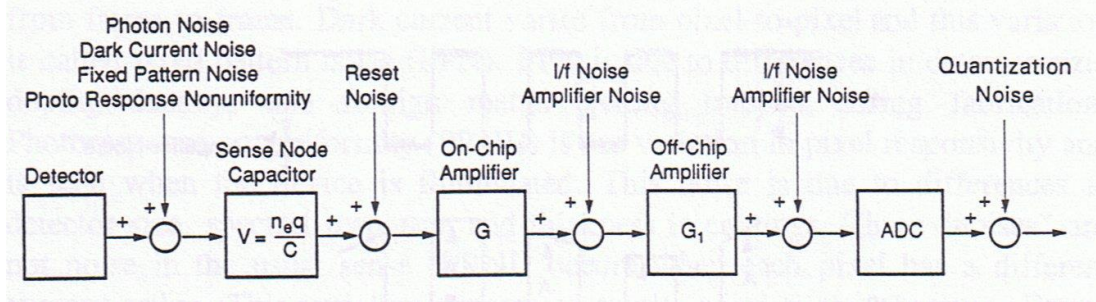

Figure 4. Categories of noise introduced from image sensor array subsections (From Holst, 1998).

The number of pixel sensor wells in array on a CMOS sensor used in digital imaging varies according to sensor size and density. Higher resolution cameras have larger sensors, but also smaller (denser) pixel sensor wells. The Astro Design 4K camera system has a 1.25-inch CMOS sensor, yielding approximately 8.3 megapixels, as compared to approximately 2 megapixels for an HD (1080p) sensor.

When a photon hits a sensor well, it charges a gate capacitor. The charge generated varies with the amount of photons hitting the sensor well and according to the color mosaic of red, green and blue filters in a layer above the wells. There is one filter for each well and the pattern is 50% green, 25% red and 25% blue. Known as a Bayer pattern, this allows data from the sensor to be reconstructed into a viewable, color image. This is known as de-Bayering. The transformation formula is weighted to favor a luminance signal, as this is used to construct the luma of each color channel (e.g., dark blue versus light blue).

When considering an image capture device for our purposes, it is important to consider all of these attributes. A wide DR allows for the use of the imager in the wide variety of environments common in tactical situations. It is apparent that a quality device with minimal associated noise is important to ensure the images captured are as close to true representations of to QR codes as possible.

2. Adaptive Optics

“Adaptive optics is a scientific and engineering discipline whereby the performance of an optical signal is improved by using information about the environment in which it passes. It’s a method of automatically keeping light focused when it gets out of focus” (Tyson, 1998). Two basic solutions exist when light is encountered out of focus. The first option is to move the sensor to the location where the light is focused. The second is to apply a correction to bring that beam into focus.

The sources of intensity variations of light that cause a need for adaptive optics are many. They are due to turbulence, optical manufacturing tolerances, equipment misalignments, thermal effects, and fluid properties. As the potential ranges for QR code communications increase, the primary mechanism that causes optical aberrations is atmospheric perturbations resulting in optical turbulence.

Small, naturally occurring changes in temperature along the path of the optics cause small changes in wind velocity. These changes result in small changes in atmospheric density thus altering slightly the index of refraction. Each of these small changes has an inconsequential effect as the optical wave front passes through. Cumulatively, however, over a long distance these changes can have some measure of effect (Tyson, 1998). While this study has not reached a distance where these effects can be expected, as the capability progresses, effort must be taken to ensure the QR images are received as intended. When QR code communications reach maturity, very small QR bits will be detected over very long distances—even the slightest distortion of the image could mean the difference between the successful relay of a message or complete failure.

There are many ways that optical aberrations can be overcome in an imaging system. Conventional approaches use wave front sensors, electronic controls and corrections optics. Passive methods involve reconstruction of known distorted images by centering around positively identifiable non-distorted portions. Unconventional methods use the nonlinear properties of specific optical materials to make corrections (Tyson, 1998). There is no true need for adaptive optics at this point in the development of QR code communications. As ranges are increased however, it is important to consider implementation of these techniques to ensure reliable long-haul optical communications.

III. PROBLEM DESCRIPTION

A. LOS COMMUNICATIONS OVERVIEW

Naval LOS communications have a critical role in tactical operations among naval units. These communications are supported by three segments, HF, VHF and UHF, each having their own strengths and weaknesses. To better understand how QR code communications fit into tactical naval operations, we must first understand in which areas it can provide benefits over LOS communications and in which situations it is simply not practical.

RF communications are inherently less secure due to their energetic nature, which allows an adversary to detect, intercept, and potentially exploit. Optical LOS communications are significantly more difficult to detect because they require an adversary to be in specifically the right place at the right time. In addition, if the streaming of QR codes comes to fruition, the refresh rate on the display will be high enough that most will be unable to capture a single, complete QR image. As with RF LOS communications, an added layer of cryptography can be added for more secure QR code transmissions.

Visual communications historically have provided the primary means for the local tactical operation and administration of the fleet. In modern naval operations, there is a natural tendency to depend more and more upon radio with a constant neglect and inefficiency of visual communications. Before RF technology provided the primary means for communications in the fleet, no messages were authorized to be sent via radio if it could be sent by land wire or visual means. The positive necessity for radio silence on the part of vessels engaged in naval operations during war was absolute. For these reasons the importance of adequate and proficient visual communications was apparent (Lewis, 1928).

1. HF

HF communications are those RF communications that occur between the frequencies of 2 MHz and 30 MHz. HF communications can be used over distances up to

8000 km given ideal environmental conditions. HF communications can provide data transfer up to 4800 bps. The HF spectrum is a limited resource, so effective use of the spectrum is especially important (Starling, 2008).

2. VHF

VHF communications are those RF communications that occur between 30 MHz and 300 MHz. The military specifically uses several bands depending on the application. The 30 MHz to 88 MHz and 108 MHz to 156 MHz bands are used for communications. 156 MHz to 174 MHz is used for maritime radiophones. 225 MHz to 300 MHz is used for tactical LOS communications. The propagation of VHF communications, unlike HF, is not affected by the environment; therefore the range of VHF is limited to the LOS. LOS can be extended by increasing the height of the antenna. Multipath interference is an issue due to signal reflection over water (Starling, 2008).

3. UHF

Similar to VHF, the military uses two specific bands for communications. 300 MHz to 400 MHz is used for tactical LOS communications and 950 MHz to 1150 MHz is used for protected (anti-jam) radios. Multipath interference is an issue due to signal reflection over water (Starling, 2008).

4. Flag Communications

For centuries flags were the only form of communication between ships too distant to hail one another, and between ships and the shore. The language of flags was developed to express several different kinds of information to overcome this shortfall. In the 19th century, signaling with special flags developed into a system capable of passing elaborate messages between any two ships. One major benefit to this type of communication was that even if the crews had no common language they could still understand one another. Though RF communications are the primary means in today's environment, flashing light is not completely obsolete (Wilson, 1986).

Political and dynastic events over several centuries affected the history of the varied flags used by British and other ships. Naval tactics, seaborne trade, and ship

communications technology has shaped their use at sea so significantly that the history of sea flags is inseparable from general maritime history itself (Wilson, 1986).

Flag Semaphore was used primarily for dispatch work. During the daylight hours was the most rapid means of visual communication for this purpose making its use universal (Lewis, 1928).

Flag hoists were and still are employed during daylight, when visibility conditions permit. Signals are transmitted using various combinations of flags and pennants each with specific meaning. With minimum effort, a large amount of dispatch work can be transmitted by means of flag hoist signals (Lewis, 1928).

5. Flashing Light

Flashing light communications are very efficient for transmitting messages over long visual distances under appropriate conditions. Similar to flag communications, coded light signals can be used to pass standardized messages across a language barrier. Unlike flag communications, signal communications can be used both in daylight and under the cover of darkness. Flashing light communications in the modern Navy hold significant value but have largely been driven to obsolescence by RF communications. Following, are several examples of flashing light communications historically used by the U.S. and other navies.

Searchlights are used during darkness and at long range or under conditions of low visibility during daylight to transmit visual signals. Even though ships are unable to see one another during periods of reduced visibility, it is possible to transmit signals using high-powered searchlights (Lewis, 1928).

Yardarm blinker communications offer a rapid, economical and very convenient method for passing information at night over moderate ranges. It was common practice in the fleet to use yardarm blinker generally for night dispatch work at sea and in port, and to use searchlight for maneuvering signals. Yardarm blinkers are faster and much more efficient than high-powered signal searchlights, and for those reasons were typically preferred if conditions were permitting.

Blinker tubes were designed for use as a flashing signal light with an extremely narrow FOV. They were intended for use when the fleet was darkened in order to prevent disclosing its presence of the locations of the individual ships. The construction of the tubes restricted the light to a very small arc allowing them to regulate intensity to prevent light from being visible beyond the desired message recipient.

The Aldis lamp was a hand signal lamp with a pistol grip. The trigger on the lamp tilted a p[arabolic mirror to bring the light beam to coincide with the LOS through the sighting glass mounted on the barrel. This mechanism was used to create the Morse code dots and dashes comprising the desired message. The Aldis lamp was adopted during WWI, but at the time, its usefulness to the fleet was widely unknown. The lamp was small and lightweight, therefore it was especially useful on small vessels, submarines, and patrol craft where hard mounted mechanism were not available (Lewis, 1928).

6. Other Methods

Wigwag was used very seldom in the Navy, but was not without its merits. It was readable at much greater distances than the semaphore but was a slower means of communication. Principally, it was used to communicate with shore stations (Lewis, 1928).

The following types of pyrotechnic signals have been used: star rockets, shower rockets, smoke rockets, Very's starts, rifle lights, blue lights, red lights and flares. Pyrotechnics were used principally as recognition signals, contact signals, night emergency signals, special signals during maneuvers, special aircraft signals and distress signals and are often used today to send standardized messages (Lewis, 1928).

Dayshapes are typically not used by the Navy for purely signal transmission purposes. They are used, however, to provide the status of a vessel to other units in the area. For example, dayshapes can convey when a vessel is at anchor or restricted in its ability to maneuver.

B. QR SIGNALING DATAFLOW

The 2011 CRUSER Warfare Innovation Workshop (WIW) provided the genesis for the concept of using QR codes as a means of tactical communications. Excerpts follow.

Concept generation is one of CRUSER's basic design tenets, and this workshop's primary goal. The mission directive given to the teams was to generate ideas and concepts for employing UxS in dangerous and dirty environments to accomplish specific missions. They were asked to emphasize current or programmed systems where incremental or evolutionary technical changes could have revolutionary operational effects. What follows is a summary of their resulting out-briefs. (WIW, 2011, p. 9)

Specifically, the members of Team Piranha identified this potential capability and coined the term: Digital Semaphore.

Simple data matrices like quick response (QR) codes or bar codes can be displayed on digital screens (or use physical panels that flip over from white to black). The message recipient uses a high resolution camera (a satellite, airplane, UAV, etc.) to view the image and process the code into usable data. The message sender could be a semi-submersible UUV that can get to the surface but does not want to expose itself. The concept could also be used for sending messages between ships, ship to shore, shore to ship, etc.

This concept's benefits include: a low observable signature because the message sender is not actively transmitting a signal, low power required because there is no active signal, potential for long range because it would only be limited by the camera's power, applicability to many platforms (e.g. UxS, ships, aircraft, satellites, shore sites, covert embedded assets, etc.), a relatively high data rate compared to many other passive communications systems, and it could be used not only in the visual spectrum, but also with IR if heated panels are used, or radar if panels with different radar reflectance are used.

The drawbacks to this concept include: it is limited by environmental conditions such as line of sight, visibility, haze, clouds, dust, etc.; it is potentially difficult to receive a message from non-steady platform such as a USV at long distances; if two-way communications are desired, a high resolution camera on both platforms to receive messages is required. (WIW, 2011, pp. 23–24)

As demonstrated through a follow-on CRUSER-sponsored workshop, the ability to create and display QR codes can be achieved easily. The increasing use of online and offline QR code creation applications in industry and the availability of digital signage allow users to find, encode and decode these two-dimensional (2D) barcodes with few barriers to success. This research has shown that eventual QR code use in a tactical environment will require specialized equipment, signal processing, and specific procedures in order to fully implement the technology (Digital Semaphore, 2012).

The QR workshop identified eight major concepts that make up the complete chain of events for data transfer via QR code. Each concept is required for success and has many factors that contribute. These factors are: message encoding, message segmenting, QR code images, image display, LOS, image capture, image processing, and message decoding. These concepts are bounded by data input and data output (Digital Semaphore, 2012).

An Electro Magnetic Maneuver Massive Multiplayer Online War Game Leveraging the Internet (EM² MMOWGLI) was conducted to explore the vulnerability that exists inherent to the technological nature of modern warfare (<https://mmowgli.nps.edu/em2>). The three phases of the game were:

- Know the EM Environment: Understanding EM Energy
- Be Agile: C2 in the EM Environment
- Paradigm Change: Tactical Employment of EM Weapons

As a result of the EM² MMOWGLI, five action plans focused on QR code and other means of visual communications emerged:

Action plan 25 was titled QR Code Characteristics for Optical Signaling and Streaming Transmission. This plan introduced the idea of using QR codes for optical communications between tactical environments. Action plan 27 was titled DFL for Unjammable LOS Signaling Between Navy Ships. This plan looked beyond the limitations of QR code by coupling existing light display capabilities with a system from controlling those lights for tactical communications. Action Plans 26, 39, and 40 demonstrated sound tactical applications for the use of QR codes in communications. These plans are titled: Tactical QR Code Streaming: High-Speed Optical Signaling for

Fleet and Unmanned-System Communications, QR Code IFFN: Identification Friend, Foe or Neutral, and Vertical QR Message to Aircraft and Spacecraft.

The EM2 war game provided valuable input from the MMOWGLI community assessing the validity of this research (EM2 MMOWGLI, 2013)

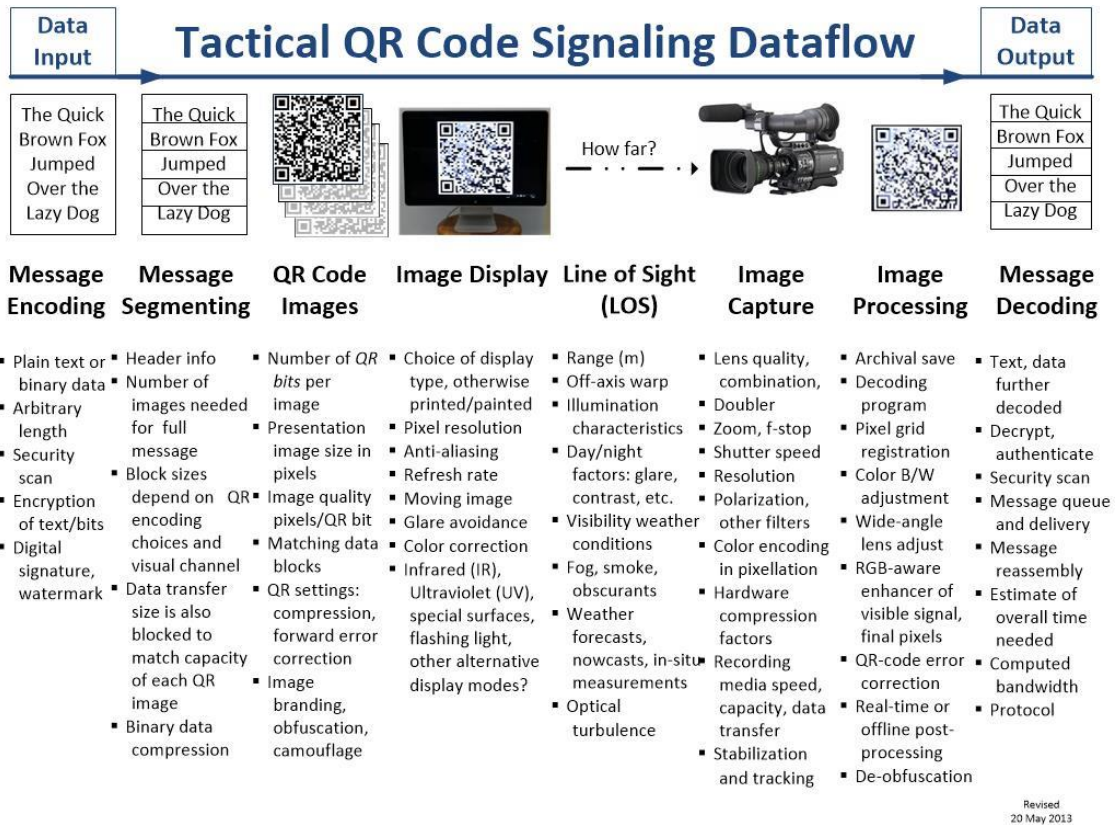

Figure 5. Ideal dataflow for a tactical QR code communications system considering end-to-end technology factors (From Digital Semaphore, 2012).

1. End-to-end Technology Blocks

As seen in Figure 5 and in the sections below, there is a general symmetry from one end of the dataflow to the other. Examples of this symmetry include security scans during both message encoding and decoding and color adjustments as images are displayed and captured.

a. Data Input

The input into the QR code communication system varies in nature, but in all cases, it is data in a particular form that must be transmitted to a separate entity. For the purposes of this study, these data are tactical in nature, but future implementation of such a system is not limited in such a fashion. Future work might connect this data channel to any message stream or communications system.

b. Message Encoding

The data sent in a QR code is typically textual in nature and various character sets are supported. The potential exists to transfer large images or other non-text files exists, but the data may need to first be converted to alphanumeric, binary, hexadecimal (0-F), or some other text-based character set (e.g., base-64). A strictly numerical (0–9) character set can allow the largest amount of data to be included in a given QR code. The content of each message itself is arbitrary and is ultimately determined by the source code used in the QR code application.

Several security features are easily built in at this stage using various methods. Security scans typical to most computer systems can be used to ensure any entered data is free of malicious software. Though it consumes a measure of overhead, National Security Agency (NSA) approved or public key encryption standards can be incorporated to ensure privacy in the case the QR code is intercepted and decoded. Digital signatures and watermarks can also be incorporated as part of the binary data stream to ensure non-repudiation and authenticity.

c. Message Segmenting

To transmit large amounts of data, a single message is divided into multiple segments similar to transmission control protocol (TCP) packets. Each QR message segment might also contain a header specifying further characteristics such as the number of QR images needed for the full message and any other information of interest. The size (QR version) of each QR code image is driven by QR encoding choices and physical system capabilities. The data size in each segment is blocked to match the

capacity of each QR image. When applicable, binary data compression can allow for a greater amount of information to be encoded into a given QR code. If a binary data compression algorithm is added, it needs to be applied prior to any segmentation occurring to achieve the best results.

Higher versions of QR codes can hold larger amounts of data, thus reducing the overall number of segments required for a large message. In most cases though, data transfer size is controlled by a larger number of smaller QR codes. When a smaller QR code is fit into the equivalent space of a larger code, each QR bit is physically larger and the likelihood of a successful capture at the receiving end is increased.

d. QR Code Images

Matching data blocks, required pixel size of QR bits, QR quality, QR compression and QR forward error correction (FEC) all factor into the generated QR code for a given transmission. Each of these characteristics is used to determine the QR version and thus the number of QR bits in each image and the size of the presentation image, in pixels (International Organization of Standards, 2006, September 01). These settings are built into the QR code standard (an interesting detail is that no official option is provided for zero FEC). Further information regarding the format of QR codes can be found in Chapter IV, Appendix A, and the ISO standard for QR codes.

It is in this stage that additional methods to optically enhance or alter the QR code are implemented. Image branding is a special case that deliberately sacrifices some of the data QR bits to insert an instantly identifiable logo. FEC allows this QR code to remain functional despite the missing QR bits. Obfuscation and camouflage may also be used insert additional data or to hide the QR code in plain sight such that intended recipients can find it while all other parties remain oblivious.

e. Image Display

The image display is a critical portion of the technology chain, but the specifications can vary greatly with little impact to success. Key factors to consider with a digital display are pixel resolution, anti-aliasing, refresh rate, and color correction.

Resolution is typically not a significant factor because most optics are not able to resolve QR bits anywhere near the size of a single pixel on the display unless the QR code is small and the receiver is in close proximity. The extent to which resolution should be considered is to ensure clean transitions between QR bits of 1 and 0 (black and white respectively). Brightness and contrast, however, are significant on a display so that the capture device is able to distinguish between those QR bits.

Anti-aliasing, when used conservatively can be beneficial if optical effects result in distortions in the transitions between QR bits. If applied too liberally, however, QR bit patterns could be mistaken for jagged edges and inappropriately altered.

The refresh rate of an image display is critical when displaying streaming data. It is important to synchronize the image capturing device with the refresh rate to ensure that whole images are captured rather than partial images caught in transition between frames. Progressively scanned displays are greatly preferred since they are much more forgiving for image capture because they display all pixels of each frame simultaneously. Conversely, an interlaced display tends to produce jagged displays as alternating lines of the image are refreshed. This distinction becomes incredibly important when streaming QR data or the display and capturing device are moving relative to each other.

If color QR codes are implemented, color correction is important to assist the capture device with distinguishing each color. The introduction of only a few differing colors sometimes requires only simple color correction, but a large range of colors requires sophisticated (and error prone) correction to ensure each color is distinctly represented.

Physical printouts of QR codes can be used as well, but message transmissions in this case are limited to the data amount that can be contained in one QR image. Additionally, specialized equipment must be available to print any QR code larger than a standard sheet of paper. As with resolution on a digital display, the dots per inch (dpi) of a printed display are not critical except when ensuring a clean transition between QR bits of 1 and 0 and when communicating over short distances with small codes.

In cases of both digital and printed displays, glare is an important factor to consider and eliminate. Glare can block portions of an image and cause data to wash out rendering the image unusable. Mitigation techniques include discrete image placement considering environmental factors and physical treatment of the display with glare-reducing materials. In addition, display durability is important to consider to ensure a QR code image is shown free of residue or corrosion.

Methods other than just traditional digital and printed displays should be considered depending on the communications requirements. Infrared and ultraviolet technologies have the potential to display a QR code array without the requirement of daylight, whereby the code would not be readily apparent to anyone not expecting it. Special adaptive coatings have the potential to integrate a display into existing structures. Large flat panels could potentially accommodate these coatings without sacrificing existing space for a specialized display. LED strings in motion (such as under the wings of an aircraft) can be used to generate QR codes when timing is synchronized with the receiving party. If spun in a circular pattern, polar 2D barcodes can be used with minimal programming and physical space.

f. Line of Sight (LOS)

This category includes all factors that are external to the dataflow process. Typically these are the same factors controlling maximum effective range.

For a successful QR code transmission, a clear LOS must exist between the image display and the capture device. Some obstruction may exist, not to exceed the error-correcting code (ECC) level of the QR code, without preventing success. Factors to consider are: range, off-axis warp, contrast, fog, smoke, etc.

Range is the most manageable, yet most significant factor that can prevent successful decoding of a QR code. At extreme distances, high-end cameras with large optics must be used in order to capture quality images. At these distances optical turbulence may exist and adaptive optics must be employed to account for wave front perturbations. As it turns out, optical turbulence becomes the dominant limiting factor as range capability is achieved at distances as near as 1000 yards.

Weather forecasts are important to consider when planning operations that employ QR code communications. Aside from limiting operations between sunrise and sunset, forecasts may predict when visibility conditions are favorable. When conditions are not favorable, nowcasts and in-situ measurements may help determine if conditions will clear or if other methods of communications should be explored.

LOS communications can be divided into two categories: omnidirectional LOS and directional LOS. QR codes in nature are directional, but with a setup displaying the code in multiple directions, near-omnidirectional QR code communications can be achievable.

g. Image Capture

Multiple types of devices can be used to capture QR images from a display. Still cameras can be used to capture single images and high definition (or better) video cameras can be used to capture QR image streams. Factors to consider with capturing equipment are: resolution, optical sensor capability, lens combinations, zoom, f-stop, shutter speed, polarization, color encoding in pixilation, compression, and recording characteristics.

Sensor capability and lens selection are the two characteristics that must be at the center of system design. Once these two items have demonstrated the capability to capture images at the required range for tactical employment, the remainder of the system can be designed to increase reliability and flexibility.

Many of the other listed factors are configurable after fielding. Software can assist in selecting ideal settings for a given configuration by considering the communication geometry and environmental factors.

In general, because of the higher resolution of a still image camera when compared to a single frame from a video, a still image camera is better suited to capture images at longer distances. The capture frame rate of high-end video cameras makes them better suited to capture images that change frequently. Image recording data rates can be extremely high. Stabilization and tracking must be included in a final QR code communications solution in order to fully account for relative motion between the sender and receiver.

h. Image Processing

Image processing has many factors to consider: decoding program, pixel grid registration, color adjustment, RGB-aware enhancer of visible signal final pixels, QR code error correction, and online real-time or offline post-processing. Though narrow field of view (FOV) lenses are typically used, if a wide angle lens is employed, optical distortions must be corrected for.

Following the capture device, a field programmable gate array (FPGA) might also be used for internal camera processing of the video. In situations where required corrections to compensate for environmental conditions are known, this processing is completed independent of the data contained in the image. The FPGA can be configured with many tasks such as QR code distinction, de-obfuscation, and meta data tagging. Computational photography techniques hold great promise and are an important area for future work.

i. Message Decoding

A data processor follows the FPGA to further process the data based on the contents of the image (i.e., decryption and authentication) and queue the code for decoding and delivery. In the case of streaming data, post processing should use the information in the QR code headers to reassemble the series of images back to the original state.

Once the QR portion of the image is identified, the QR algorithm is applied in reverse to convert the QR bits back to the original text. If any of the formatting data are pertinent to the message itself, it can be made available at this point. In addition, formatting data can be used to estimate the overall time needed for transmission. In the case of streaming data, header history can be used to determine current bandwidth rates and predict bandwidth required for continued communications.

Malicious QR codes may appear and be read by the system because of the non-discriminating nature of QR decoding software. Security scanning at this point is critical to reject foreign QR codes and ensure malicious code is not given access to the system.

j. Data Output

Following decoding, the useful information is available for the receiver. This information may be input for another system or a message for a user.

Decoded single-image QR codes can easily be displayed as necessary using either a video display screen or a physical printout. In many cases, a graphical user interface is appropriate to allow users to appropriately interpret and use the data.

A recorder may be used to archive or store a QR code at any point following image capture. If timely analysis of the data is not required, the raw material from the capture device may be stored. For images that are used in a short time period but not immediately, data following the FPGA are stored. Following the decoding processor, data may be archived for later use.

It is worth noting that the QR data channel can be fully standardized such that it can be applied for use with any communications system.

C. RESEARCH QUESTIONS

Which individual technologies (high resolution displays, high frame rate cameras, adaptive optics, etc.) most efficiently contribute to the end-to-end success of the system as a whole for transmitting messages via QR code?

How can equipment technology be used to mitigate the barriers to QR code communications (e.g., environmental obstructions to LOS, angular distortions, extreme ranges)?

How and in what situations is QR code communication superior to RF LOS communication?

D. SCOPE OF RESEARCH

This research includes experiments to validate the use of QR codes in a tactical environment. Initial testing establishes a baseline for performance expectations using standard COTS optical equipment and software to generate, capture and decode static QR

images. Further experimentation places these static QR codes into more dynamic situations to verify the baseline expectations hold consistent in changing conditions.

E. CHAPTER SUMMARY

LOS communications have been integral to naval operations for centuries and have significant impact even today. QR codes should be considered and developed to augment current LOS communication techniques. This chapter discussed the origins of QR code communications work at NPS and in detail, the concepts necessary for its successful design and implementation into a tactical system.

THIS PAGE INTENTIONALLY LEFT BLANK

IV. ONE-DIMENSIONAL (1D) BAR CODES, TWO-DIMENSIONAL (2D) BAR CODES, AND QR CODES

A. CHAPTER OVERVIEW

Over time, one-dimensional bar codes evolved into two-dimensional barcodes, which then led to the creation of quick response codes. QR codes were ultimately developed due to the fact that there was a growing need to be able to more effectively track inventory and the requirement to have the ability to store more data within these barcodes. This chapter will discuss the many features of QR codes that could allow them to be effective for optical communications.

B. HISTORY OF BAR CODES AND QR CODES

Bar codes have been used for many years and are versatile in their use. They are limited though in their data capacity and tend to require larger displays to be read reliably. Originally developed for cataloging railroad cars in the 1960s, one-dimensional barcodes were not commercially prolific until they were used to automate retail checkout systems in the mid-1970s. In the years to follow, the Universal Product Code (UPC) format became the standard method for representing products throughout the retail industry (Fox, 2011).

A QR code is a two dimensional bar code designed to work similarly to a one dimensional bar code but with significantly more data capability. QR codes were originally developed for Denso Corporation in 1994 (Kieseberg et al., 2010). Ultimately, these QR codes were a solution to the growing need for the ability to effectively track inventory in the automotive manufacturing industry and to have the ability to store larger amounts of data within the barcodes themselves. QR codes have been approved as AIM, JIS and ISO standards and are fast becoming a mainstream technology (Sutheebanjard & Premchaiswad, 2010). Aside from QR codes, other examples of two dimensional matrix codes are Aztec, DataMatrix, Code One, Semacode, SPARQ, MicroQR, and MaxiCode. Similarly, two dimensional bar codes can exist as stacked one dimensional bar codes such as PDF417 and Code 16K.

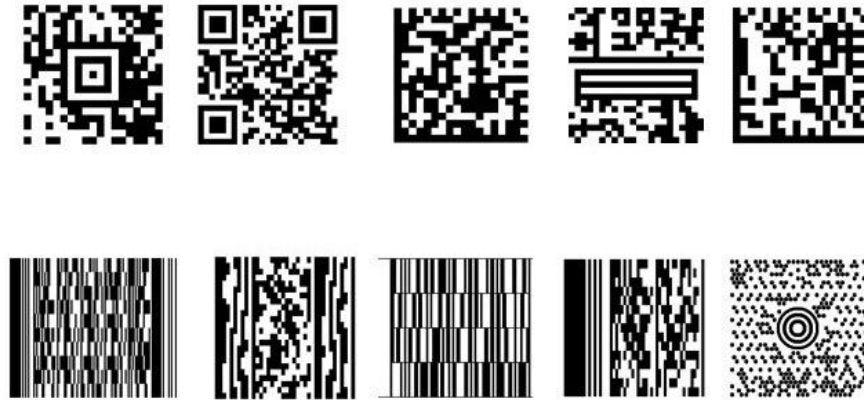

Figure 6. Side by side comparison of commonly used 2D barcodes, to include matrix and stacked bar code styles.

A common use for QR codes is to conveniently provide mobile phone users with URLs to promote websites and advertisements. As evidence to the increasing use of QR codes, URL shortening services such as Goo.gl and Bit.ly now exist. Additionally, there are countless web-based services that can be used to generate and read QR codes.

C. CHARACTERISTICS AND GENERATION OF QR CODES

The details provided in these sections provide a simple overview of the key characteristics of QR codes. The Wikipedia article on QR codes (http://en.wikipedia.org/wiki/QR_Code) is a primary resource necessary for understanding the potential capabilities and design choices presented in this work. It is provided as a ready reference in Appendix A.

A QR code is a two-dimensional binary representation of data structured using black and white patterns. The represented data can consist of numeric, alphanumeric, binary and kanji characters. Since a two-dimensional code adds data in the vertical direction as well as the traditional horizontal direction of a one-dimensional barcode, it is capable of representing magnitudes greater of data.



Figure 7. General characteristics of a 2D QR code compared to a 1D traditional barcode (From Sutheebanjard & Premchaiswad, 2010).

The patterns are comprised of black QR bits overlaid on a field of white. Each black QR bit represents a binary 1 while the white spaces or the absence of a bit represents a binary 0. Three finder patterns that look like a square bullseye are located at the corners with timing bits located between each. Because the finder patterns are always present and in the same configuration, a QR code can be detected and decoded regardless of its orientation within the plane. An added benefit of the three finder patterns is identification of the QR symbol in a complex background environment. An additional alignment pattern is added in QR codes version 2 and greater to assist in resolving codes with optical distortion.

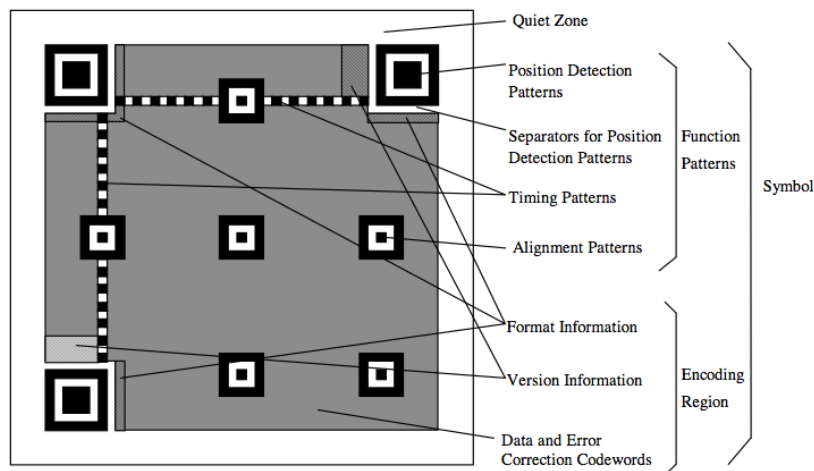

Figure 8. Key structural features of a QR code symbol (From International Organization of Standards, 2006, September 01).

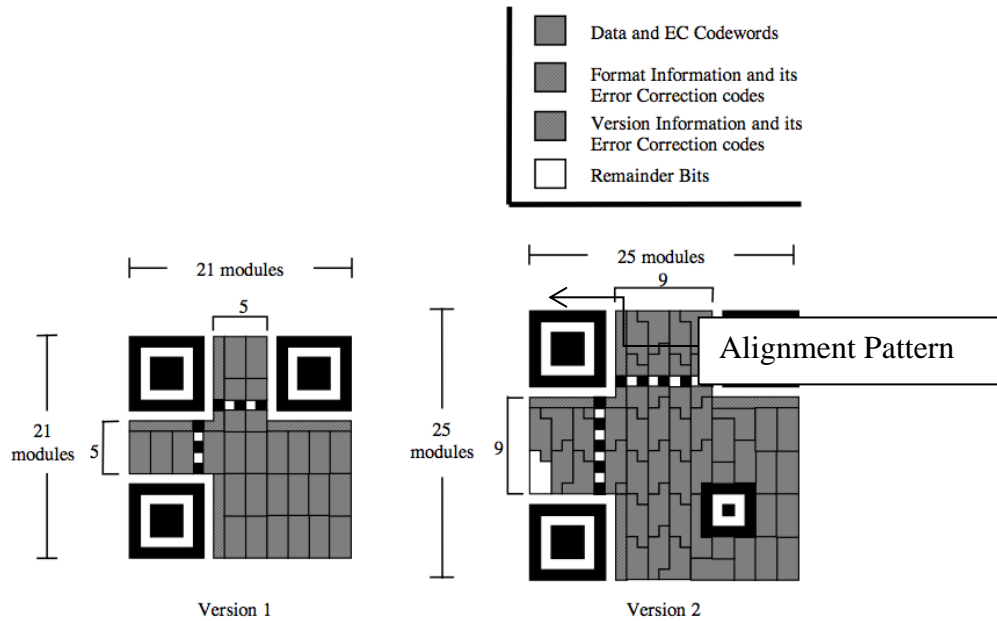

Figure 9. Comparison of version 1 and 2 QR code symbols (From International Organization of Standards, 2006, September 01).

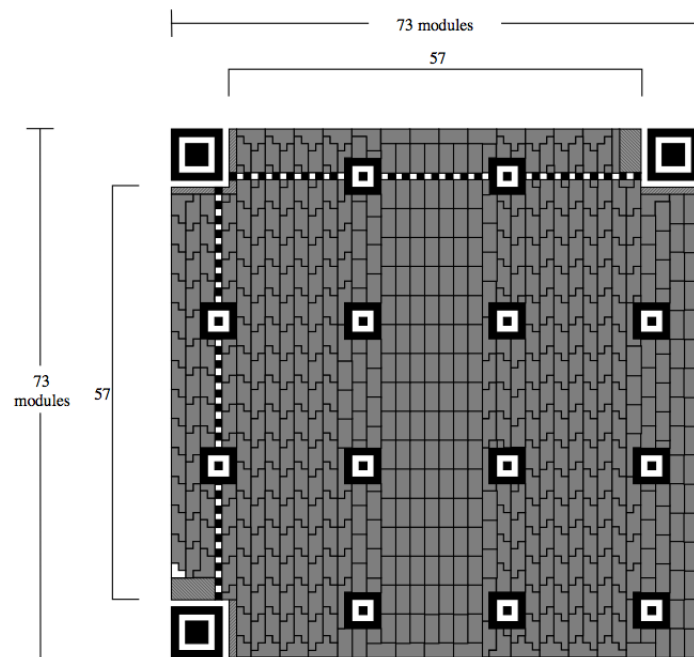

Figure 10. Characteristics of a version 14 QR code symbol (From International Organization of Standards, 2006, September 01).

Inherent in every QR code is error correcting code (ECC) to compensate for misreading a QR bit or accommodating for a portion of the image missing or unreadable. Reed-Solomon error correction provides this capability, similar to nearly all other forms of 2D barcodes. The drawback of having a larger ECC is a reduced data capacity within the code. The error correction levels are as follows (Sutheebanjard & Premchaiswad, 2010):

Level	Maximum Correction Capability
L	7%
M	15%
Q	25%
H	30%

Table 1. QR code error correcting capability levels (After Sutheebanjard & Premchaiswad, 2010).

Forty versions of QR codes exist each representing a unique amount of data that can be encoded and represented. Each version has a set capacity based on the available space in the code following the finder, timing and alignment patterns, and the version and format data (Sutheebanjard & Premchaiswad, 2010). A few capacity examples based on data types and a 7% ECC are shown below:

QR Code Version	Numeric Data	Alphanumeric Data	Binary Data	Kanji Symbols
1	41	25	17	10
2	77	47	32	20
3	127	77	53	32
5	255	154	106	65
10	652	395	271	167
20	2061	1246	858	528
40	7089	4296	2953	1817

Table 2. QR code capacity (After International Organization of Standards, 2006, September 01).

D. READING QR CODES

QR Codes can be read from a variety of readers available on the Internet and as applications for mobile phones. In addition to these readers, there are many open-source and proprietary programs that can be installed on a desktop or laptop for reading directly from files or through a webcam.

1. Mobile Devices

Nearly all modern mobile devices have the ability to scan and decode QR codes. Many free and inexpensive QR-reading mobile applications (apps) are available in the iPhone App Store and the Android Market. A few examples are NeoReader, QRReader, Scan, Quick Scan, AT&T Code Scanner, Scanner Pro, and QR Droid. A few mobile apps have the ability to create QR codes such as Qrafter, Quick Scan, QR Generator, and Market QR. Not all QR reading apps perform at the same level, but all do include the basic functionality required to read QR codes at a reasonably close distance.

2. Specialized Cameras

With the current mobile technology market it is not likely that a device will be developed dedicated solely to generating, reading, and processing QR codes or barcodes in general. If this capability were requested by a specific entity, such as the military, it would be reasonable to expect technology developers to easily develop such a product.

3. Software Implementations

Many websites exist that serve to assist with QR code functions. RACO (racoindustries.com) maintains a robust catalog one and two-dimensional barcode generators as does ZXing (zxing.org). Other websites, such as INVX (invx.com) offer simple and limited generators that are effective and simple to use. Some websites, such as Kaywa (kaywa.com), work only with QR codes, but provide detailed control when creating the codes.

Three common mechanisms currently exist with software applications that read QR codes. The first is to enter the URL of a page containing a QR code, and the service

returns the decoded version of any QR codes found on that page. ZXing (zxing.com) and MiniQR (miniqr.com) offer this service. Second, a locally running software application may be allowed to interface with a computer's webcam to capture the image of a QR code and will return the decoded version. MiniQR uses this method. Third, and the most common, a website or software application may allow a user to upload a file containing a QR image for decoding. websites that offer this functionality are Online Barcode Reader (onlinebarcodereader.com), Patrick Wied QR (Patrick-wied.at) and QR Code Generator and Recovery (esponce.com).

E. QR CODE SECURITY CONSIDERATIONS

Before QR code communications can be seriously considered for tactical military applications, proper security matching or exceeding the capability of current communication systems must be proven. While a standards-compliant QR code contains a measure of security in its current design, current security mechanisms are not sufficient to ensure the protection of the data it will carry.

1. General-Purpose Data Channel

The algorithms currently used to encode a QR code clearly prevent the data from being man-readable. These algorithms however, are derived from open-source libraries available to anybody with common Internet access. For increased security at this level, private encoding algorithms must be developed for communications among authorized users and protected from all potential adversaries.

Further security can be obtained by developing a proprietary 2D barcode format similar to QR codes or by modifying the existing format. For instance, the finder patterns can be omitted and replaced by unique patterns unrecognizable by open-source QR readers. Another option is to invert all or a portion of the QR bits such that only an intended recipient knows to recognize and account for this change.

This technique might be considered a simple Caesar cipher. Indeed, an important area for future work is to perform a comparative survey of all encryption methods and then consider what corresponding visual encryption techniques might be relevant.

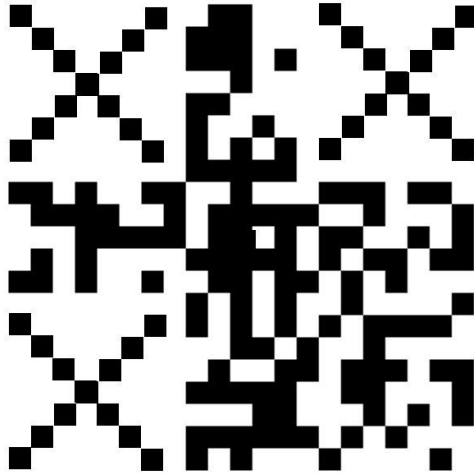

Figure 11. An artist's rendering of a QR code reading, "http://qr.nps.edu" with the traditional finder patterns replaced by alternate patterns.

2. Encryption

Traditional methods of data encryption can also be used to add a layer of security. Once a QR code communication system is implemented, in-line encryption (ILE) devices or algorithms can be used to encrypt data before it is transformed to a QR code format. With such security in place, an intercepted and decoded QR code remains meaningless to unintended recipients.

3. Camouflage

Camouflage is a viable option for obscuring a QR code from the view of unauthorized users. If the camouflage material will be directly between the display and the recipient, however, modifications to the system must be in place. The normal visible spectrum can be replaced with infrared or ultraviolet displays in order to pass through the camouflage.

4. Obfuscation

Obfuscation may also be key to ensuring communication security with a QR code system. If a QR code is placed within a complex background, human interpretation may not detect its presence. With the appropriate finder patterns in place, only an optical scanner feeding imagery into an obfuscation-aware data processing algorithm can

recognize the existence of the QR code, determine its boundaries, and extract the encoded data. Other standardized QR tools simply fail to read the image. In Figure 12, note the valid QR code identified by the finder patterns located in the center of the image.

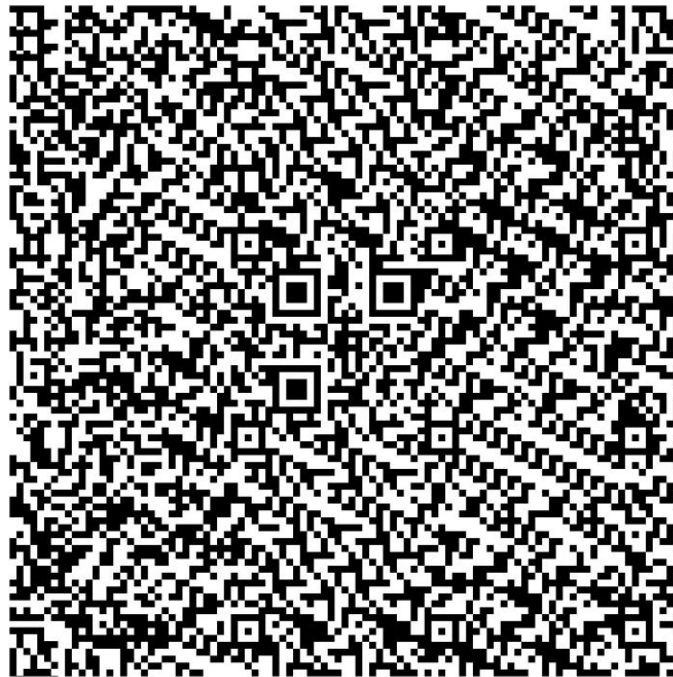

Figure 12. As an example of obfuscation, a valid QR code reading, “<http://qr.nps.edu>” is placed within a complex background. Note that in this image, the required white quiet zone surrounding the valid QR code is not present, but can be regenerated based on the reference points provided by the finder patterns.

5. Steganography

Steganography is the practice of hiding information within a message, image or file. The difference between visual steganography and obfuscation in this context is that the message in steganography is much more difficult to “stumble” upon. In Figure 12, if an observer happens to scan the image, the hidden message will likely decode since some readers are forgiving about the white quiet zone. With steganography, the hidden data is in such deliberately modified format, that only the recipient will know to expect it and know how to extract.

An example of information steganography is the use of intentional error bits in a series of QR codes to build a hidden data set. Most QR readers dismiss error bits and produce only the decoded message. Following successful message receipt, however, it is possible to deliberately construct a secondary message from the decoded text and then produce a list of erroneous QR bits by comparing the two images. Reconstruction of data can then occur by using the error bits such that when all of these bits are combined, they decode to a separate message. For example, a 1 might be deliberately changing a QR bit from white to black, and a 0 might be changing a black QR bit to white. Other variations are possible based on spatial or numeric locations in the image. Of note is that separate encryption schemes can be used in these hidden messages.

6. Vulnerabilities

URL shortening services (e.g., <http://bitly.com>) are enticing to allow a user to encode lengthy web addresses into small QR codes. Unless this shortening is performed by a known reliable and trusted source, increased vulnerabilities are increased into the system. A nefarious third party can use these services to implement malicious code through shortened URLs.

F. QR CODES FOR TACTICAL COMMUNICATIONS

1. Advantages

Arguably the most significant advantage of QR code LOS communications is the fact that they can be conducted without emitting energy in the RF spectrum. In an emissions controlled (EMCON) environment, this will provide a critical ability to communicate between ships without increasing the possibility of position detection.

This form of communication also revitalizes historical means for LOS communications such as flag semaphore or blinking light. This capability will be imperative in a communications-denied anti-access area denial (A2AD) environment.

QR codes are easily generated, easily read, and are simple to use, therefore they are much easier to support with common and available technology. Thus, the

infrastructure for deployment ashore or within a ship is already available and in place. This ready availability also reduces the need for extensive training of personnel using the technology.

A significant characteristic of QR codes is the ability to encode large amounts of data within one QR image. This allows for lengthy messages to be communicated through a QR code, which greatly reduces the time required to decode the message compared to the traditional ways of encoding and transmitting a tactical signal. A QR code is capable of containing a maximum of up to 4,296 characters if the message is alphanumeric, which is more than enough for any tactical signal. If a series of QR codes are transmitted and coupled, this opens a significantly sized data stream between two users.

QR codes are also capable of storing data in both the horizontal and vertical directions, making them an ideal platform to create and transmit messages in a timely fashion.

Because QR codes are largely unidirectional and short-range, the area in which an adversary must be stationed to detect a QR code transmission is small. This creates a significantly low probability of detection (LPD) and in turn low probabilities of interception and exploitation (LPI/LPE). As discussed above, multiple options for encrypting QR codes provide an elevated level of security against any adversary.

Beyond those reasons stated here, there are many other advantages for the use of QR codes for communications. As QR code supporting and leveraging technology continues to evolve, many other advantages will emerge that have yet to be used or discovered.

2. Disadvantages

Although the use of QR code technology as digital semaphore provides many advantages, it is also necessary to mention possible associated disadvantages associated with this type of communication.

The proper environment is essential to the success of QR communications. Sufficient lighting required to capture a QR code and have the ability to decode it is important to ensure the proper contrast between QR bits for decoding. The different types of QR code readers may react differently to changes in lighting, which can pose an issue for transmitting these signals at night or in low light situations. In a shipboard environment, where this type of communications is ultimately desired, other issues such as sea state, extreme reflections from the sun, the presence of fog or sea spray and the various different angles at which ships operate in reference to one another can all contribute to communication failures.

Angular performance must be studied in order to determine acceptable maximum angles at which QR codes can be successfully read and decoded using various sensors. It is likely that ship movements from high seas and ship positioning will all affect the angle at which a QR display is presented significantly enough to reduce the reliability of the communication channel.

With current technology, range performance for QR codes is still poor. This limits the use of QR communications to very close quarters. In a maritime environment, operations in close proximity come with significant risk and are only performed when necessary (i.e., replenishment at sea).

In the case when an adversary is located in close proximity and near perpendicular to a QR code display, the possibility of detection, interception and exploitation of the signal is elevated. Current QR code reading technology is readily available to the public and many QR reading solutions are free to smart phone users. If encryption of the QR code is weak or absent, an adversary positioned as such can easily intercept and decode the communications. In addition, an adversary can effectively jam these communications by establishing a smoke screen in the vicinity of the transmitting platform.

As technology matures, it is likely that many of these disadvantages can be overcome. It is also likely that disadvantages that have not been considered or do not yet exist will emerge.

G. CHAPTER SUMMARY

Quick response codes are capable of storing more data than one or two-dimensional horizontal bar codes in a much smaller space. Multiple versions of QR codes allow for varying amounts of data to be encoded based upon the situation. QR codes are omnidirectional, which means that they are capable of being read at any orientation. For all these reasons, using QR codes for communications is feasible, provided that an uninhibited LOS exists and each unit is equipped with the proper equipment.

THIS PAGE INTENTIONALLY LEFT BLANK

V. RESEARCH METHODS

A. CHAPTER OVERVIEW

Baseline distance and angle simulation used during the research of QR codes are described and documented in this chapter. An accurate baseline will allow prediction of the performance of any given image capturing technology. In addition, field experimentation to include distance validation, satellite experimentation, and UAV experimentation are described.

B. SIMULATION

Simulation was conducted by varying QR code size to simulate various distances in order to predict maximum distances at which various optical devices could resolve a QR code for decoding. The outcome of this simulation are the charts in section VI.E.1 (Figure 48, 49, and 50), which correlates the image device configuration to the size of the image captures, resulting in the ability to predict the performance of any sensor/lens combination. The chart, based on the size of the image predicts with relative certainty the maximum distance at which a device can resolve a QR code based on the pixel density of its sensor, the focal length of the lens and the physical size of the QR code.

Critical characteristics that factor into this simulation are broken into two categories, digital array performance and camera performance characteristics. The most common array performance measures are read noise, charge well capacity, and responsivity. Minimum signal, maximum signal, SNR and dynamic range can be derived from these measures (Holst, 1998).

1. Baseline Distance Simulation

This test simulated the reading of QR codes from various distances by using a proven distance at which the test QR code image could be decoded while varying the size of the displayed image. For each device tested, the maximum simulated distance for QR code resolving was determined and plotted against the pixel densities listed below. A controlled indoor environment was used in which light levels and capture distances were held constant.

Model	Resolution (Megapixels)	Sensor Size (mm x mm)	Sensor Well Density (Megapixels per mm ²)
iPhone 4S	8	4.54 x 3.42	0.51
Canon Powershot SD880	10	6.2 x 4.6	0.35
Canon 5D MkII	21.1	36 x 24	0.024
JVC GY-HD200 720p	0.9	6 x 4.8	0.032
JVC GY-HM750 1080p	2.1	6 x 4.8	0.072
Canon DC420	1.07	2.4 x 1.8	0.247
GoPro HERO3	8.3	6.17 x 4.55	0.295
WorldView-1 Imager	24.9	Unknown	Unknown
WorldView-2 Imager	33.6	Unknown	Unknown

Table 3. Imaging equipment characteristics for simulation and field experimentation.

Four categories of simulation occurred: Still image capture of digital image display, still image capture of printed image display, video capture of digital image display, and video capture of printed image display. For digital image display, the test image was initialized at 17 inches wide by 17 inches tall (100%) and varied in 1% decrements to a minimum size of 0.85 inches by 0.85 inches (5%). For printed image display, the test image was printed in 1% increments starting from 0.32 inches by 0.32 inches (5%) to 8 inches by 8 inches (100%).

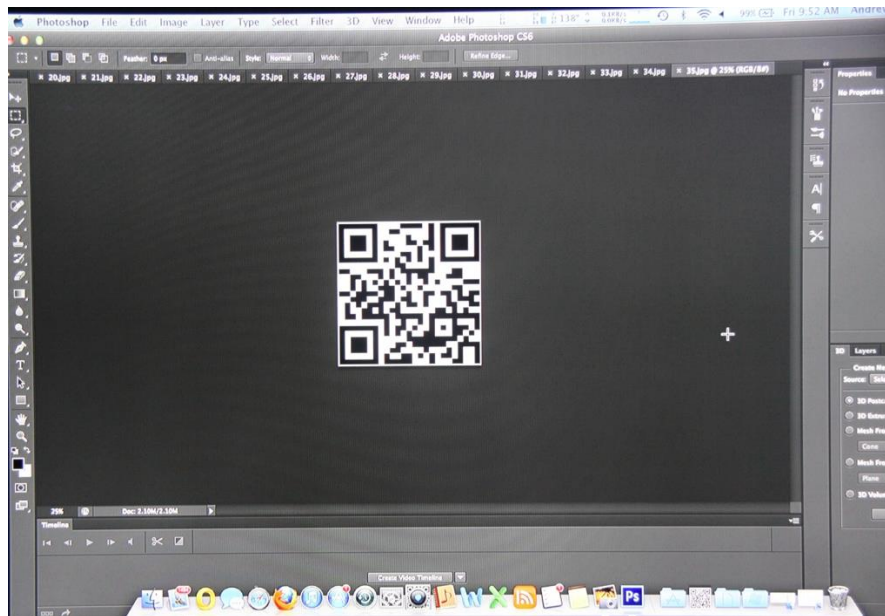

Figure 13. Capturing a digitally displayed 35% QR code image during simulation.



Figure 14. Capturing a print displayed 80% QR code image during simulation.

2. Angle Simulation

This test simulated the reading of QR codes from various angles by using a proven distance at which the test QR code image could be decoded while simulating various angles of the displayed image. For each device tested, the maximum simulated angle (measured against the perpendicular) for QR code resolving was determined. A controlled indoor environment was used in which light levels and capture distances were held constant.

Four categories of simulation occurred: Still image capture of digital image display, still image capture of printed image display, video capture of digital image display, and video capture of printed image display. For digital image display, the test image was initialized at 13.25 inches wide by 13.25 inches tall and varied in 1 degree increments off-perpendicular to a maximum angle of 85 degrees. For printed image display, a 4 inch tall by 4 inch wide test image was varied from 0 degrees off-perpendicular to 85 degrees.

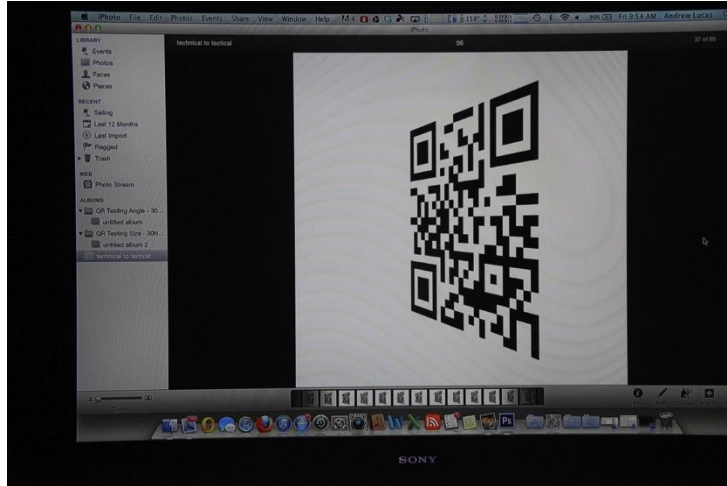

Figure 15. Capturing a digitally displayed 56 degree off-perpendicular QR code image during simulation.

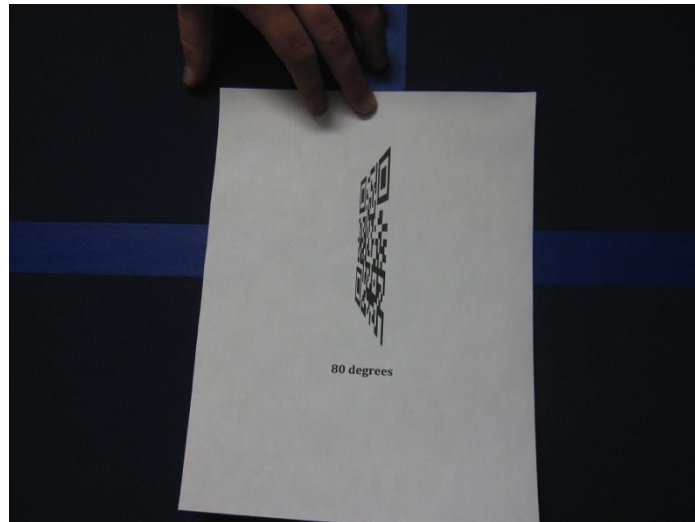

Figure 16. Capturing a print displayed 80 degree off-perpendicular QR code image during simulation.

Figure 17 shows an extensible 3D (X3D) tool useful for displaying a QR code at various angles. This tool allows a user to easily simulate angles as much as 90 degrees off perpendicular and makes further angular simulation testing simple. Compared to the manual methods used in the angular simulation discussed, the X3D simulator greatly reduces image preparation time and discretely displays any specific angle.



Figure 17. X3D image simulation tool displaying “<http://qr.nps.edu>” at an angle of 36 degrees from a perpendicular viewpoint.

3. Image Preparation

For all simulations, a QR code generated from the RACO Industries’ QR Code Barcode Generator was used (<http://www.racoindustries.com/barcodegenerator/2d/qr-code.aspx>). This generated code has the following parameters:

Version	2
Error Correcting Code	L (7%)
Size	25 X 25
Max Alphanumeric Capacity	47 characters
Value	From technical to tactical

Table 4. Test QR code image parameters.

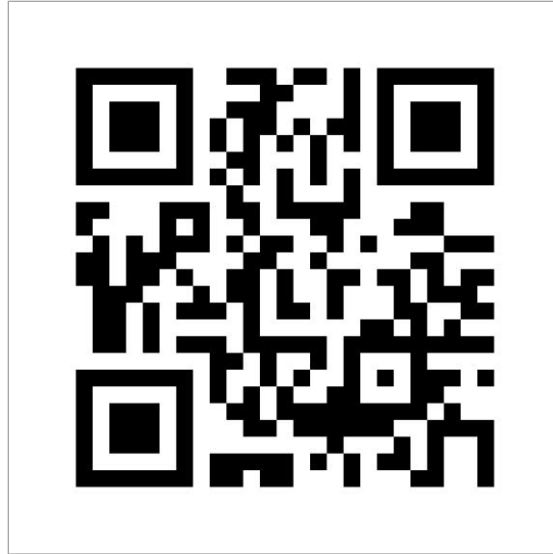

Figure 18. Test QR code image: “From technical to tactical.” Version 2, ECC L (7%), 25 x 25 QR bits. Note the necessary standards-compliant inclusion of the quiet zone 4 QR bits wide.

For digital display, the QR code was resized so that it was as large as possible yet still fit on the screen of the test display. This initial QR code was considered 100% for digital display purposes. Using Adobe Photoshop, the 100% image was decreased in size in 1% increments down to the smallest size of 5%. Each sized increment was saved as its own image test file. For the angular simulation, an initial QR code was saved and labeled as zero degrees representing a straight-on view of the code or a view from the perpendicular of the plane it occupies. Again, using Adobe Photoshop, the image was rotated about the Z-axis in one degree increments to a maximum simulated angle of 85 degrees. Each angled increment was saved as its own image test file.

For the printed displays, the QR code was resized so that it was as large as possible yet still fit on a single sheet of 8.5” x 11” paper. This initial QR code was considered 100% for printed display purposes. Using Adobe Photoshop, the 100% image was decreased in size in 1% increments down to the smallest size of 5%. Each sized increment was printed. For the angular simulation, the angular QR codes used for digital display were each printed on individual sheets of 8.5” x 11” paper.

C. FIELD EXPERIMENTATION

Field experimentation was conducted from October 2012 through April 2013 to analyze the benefits of the various technologies in an end-to-end assessment of the QR code communication chain. Specifically, equipment was assessed based on image sensor resolution and optical focal length. This will help identify the ideal technologies to enable QR code communications with acceptable tactical performance parameters.

Range testing was used to validate the distance simulation by recreating the simulated events using actual distances. A large version of the test QR code measuring 37.5 inch x 37.5 inch was constructed on a plywood stand for longer range testing. The plywood was painted white to provide the QR code background and 1.5 inch x 1.5 inch QR bits were glued to represent the test pattern.



Figure 19. Field testing QR display stand constructed of basic lumber and plywood. Test QR code image: “From technical to tactical.” Version 2, ECC L(7%), 25 x 25 QR bits, 37.5 inches x 37.5 inches.

1. Range Determination

Initial range determination testing took place in the Spruance courtyard next to Spanagel Hall at NPS. At this location, a maximum possible LOS for testing of approximately 220 yards was achievable. Images of the test QR code were collected using the iPhone 4S, Canon SD880, Canon 5D, Canon DC420, JVC GY-HD200 and JVC GY-HM750. With each camera, images were captured at approximately 10 yard intervals from 20 to 200 yards.

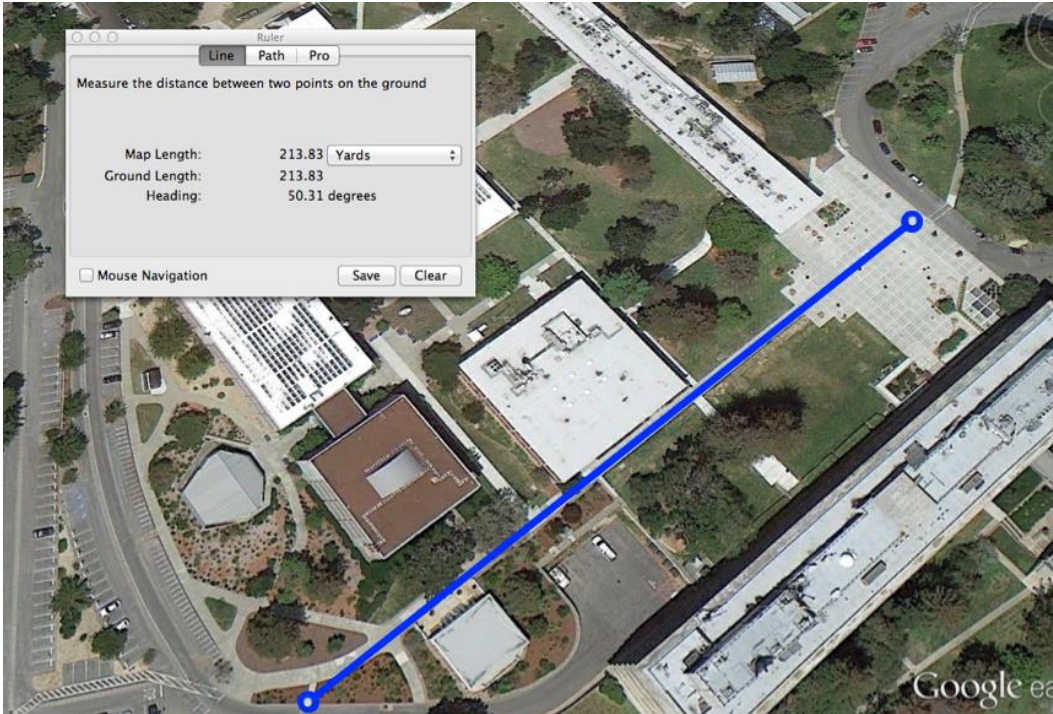

Figure 20. NPS LOS Location: 215 yards available between the Hermann Hall circle and the main gate (After <http://maps.google.com>).

Distances of from the point of each captured image to the test QR code were measured using a Bushnell Laser Range finder. In Figure 21, the planter on the right was 16 yards and the picnic table on the left was 38 yards from the QR code.



Figure 21. Test Image Placement at NPS in the Spruance courtyard next to Spanagel Hall facing the Hermann Hall Circle.

Range determination testing beyond 200 yards took place at the Fort Ord Motor Pool lot. At this location, a maximum possible LOS for testing of approximately 650 yards was achievable. Images of the test QR code were collected using the iPhone 4S, Canon SD880, Canon 5D, Canon DC420, JVC GY-HD200, JVC GY-HM750, and GoPro HERO3. With each camera, images were captured at approximately 10-yard intervals from 200 to 500 yards.

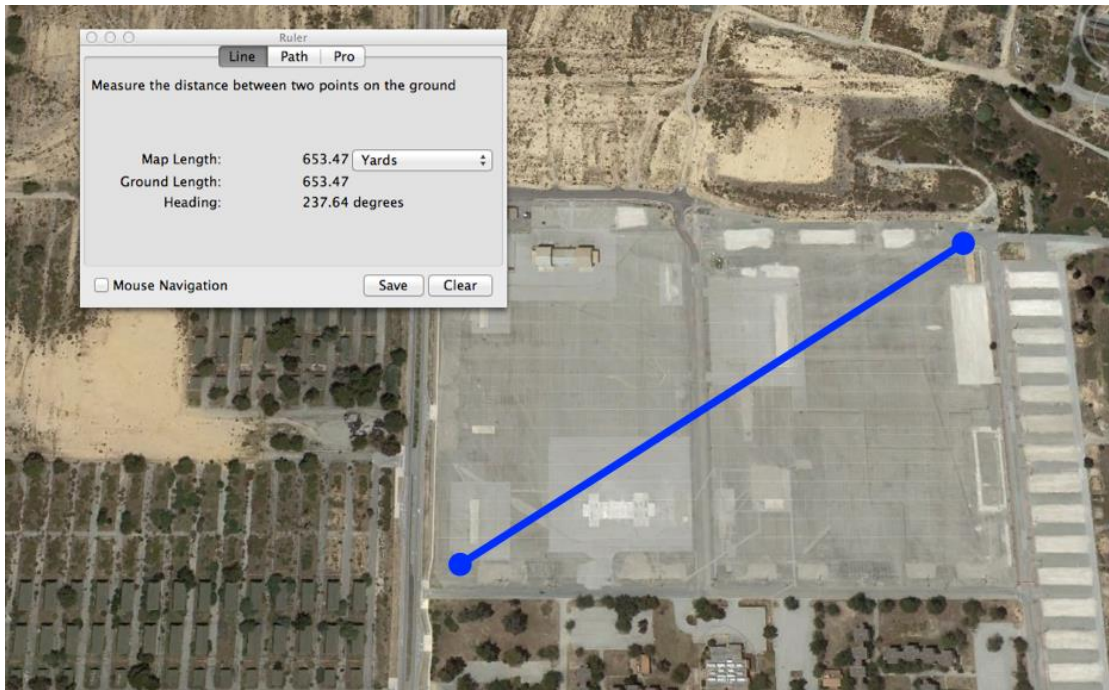

Figure 22. Fort Ord LOS Location: 650 yards available diagonally across the asphalt lot at the motor pool (After <http://maps.google.com>).



Figure 23. Test image placement at the Northwest corner of the motor pool lot at Fort Ord.

As with the range testing at NPS, the distances from camera to test image were measured using a Bushnell Laser Range Finder.



Figure 24. Bushnell Elite 1600 ARC laser range finder used for distance determination during all field testing. Capable of determining distances of 6 to 1600 yards. (From <http://www.bushnell.com>).

2. Satellite Capability Demonstration

To demonstrate the ability to send data to high altitudes either to aircraft or spacecraft, a large QR code was painted on the roof of King Hall. A field of white exterior latex paint was applied with a sprayer to the rooftop in a square pattern approximately 45 feet by 45 feet. Within the background, black 1.64 foot QR bits were

masked and sprayed to match the test QR code pattern. 1.64 foot QR bits were selected based on the anticipated resolution of the overhead sensors available to capture images.



Figure 25. Complete view of King Hall QR code from atop Spanagel Hall.



Figure 26. Conceptual aerial View of King Hall QR Code using commercial open-source overhead imagery (After <http://maps.google.com>).



Figure 27. Aerial view of King Hall QR code using commercial overhead imagery captured from DigitalGlobe Worldview-1 dated 14 April, 2013.

Official safety procedures were observed while working aloft on King Hall, with corresponding setup and teardown labor costing approximately \$1000. Costs included labor to provide roof access, setup of visual safety barriers and worker safety training. The NPS Public Works department provided an industrial paint sprayer and operational training.



Figure 28. Safety setup at the work area entry point atop King Hall.



Figure 29. Safety setup atop King Hall showing the complete work area including visual safety barriers and entry point.

3. Limited Camp Roberts UAV Test

A site survey was conducted at Camp Roberts to determine the feasibility of various field tests at that location. During the site survey, the intent was to affix a 16 inch by 16 inch QR code to the underside of the UAV from the ARSENL lab and capture images of opportunity based solely on the set flight plan. ARSENL did not fly, so the opportunity was lost. PSI Corporation was present the same day and was flying their multi-rotor UAV presenting another opportunity for imagery collection. A 16 inch by 16 inch QR code was affixed to the runway and the InstantEye UAV completed several

passes over top collecting video. The UAV provided video from three cameras: stock, GoPro, and LWIR. The stock video camera provided standard definition interlaced video. The GoPro camera provided high definition interlaced video. The LWIR camera provided high definition progressive video.



Figure 30. PSI Corp. InstantEye quad rotor UAV.



Figure 31. InstantEye HD video capture of the test QR image on the runway at McMillan Field, Camp Roberts.

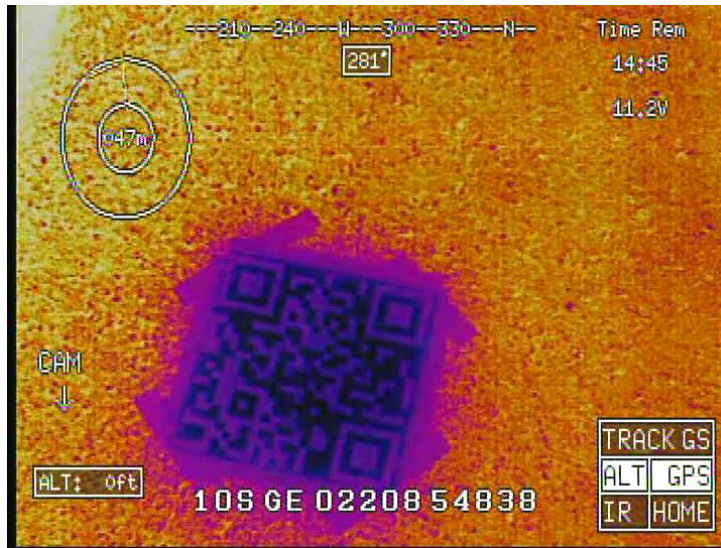

Figure 32. InstantEye LWIR video capture of the test QR image on the runway at McMillan Field, Camp Roberts.

Much more testing is needed. Important future work includes placing a permanent marker on the McMillan airfield runway to support test and calibration during UAV operations conducted as part of ongoing NPS field experiments.



Figure 33. Artist's depiction of potential QR code locations at McMillan airfield using commercial open-source overhead imagery (After <http://maps.google.com>).

D. CHAPTER SUMMARY

Nine different video and still image cameras were used during the simulation and field experimentation portions of this research including commercial satellite imagers. Results for each type of camera were documented following the baseline simulations, field experiment validations, and satellite and UAV demonstrations.

VI. EXPERIMENTAL RESULTS AND ANALYSIS

A. CHAPTER OVERVIEW

1. Maximum Range Capabilities

Table 5 shows the maximum distance for each camera, in yards, that the QR Code test image was successfully captured and decoded. In all cases, with the exception of the iPhone 4S, digital image magnification was required for success. For the iPhone 4S, secondary evaluation provided no range increase over direct evaluation of the raw image.

Still Image Cameras		Video Cameras	
iPhone 4S	67	Canon DC420	284
Canon SD880IS	85	JVC GY-HD200	345
Canon 5D MkII	428	JVC GY-HM750	457
		GoPro HERO3	40

Table 5. Maximum distances, in yards, at which a QR code was successfully captured and decoded for each camera.

2. Equipment Variances

It is important to note that comparisons between differing equipment are general, but each camera and each lens has its own inherent variations based on construction and manufacturing tolerances. These variations are not controlled for in our experimentation.

Because two apparent variables emerged when classifying the image capture equipment, a Camera Capability Factor (CCF) was defined to more appropriately organize the data. The capabilities of each imaging device are mainly dependent on the image sensor resolution and the size of the lens. To combine these into a single variable, the CCF was defined as follows:

$$CCF = Resolution \times Focal Length$$

where the resultant number is measured in MegaPixels X mm.

3. Result Categories

In all cases, image performance results in one of three categories: direct evaluation, secondary evaluation, or unsuccessful evaluation. Direct evaluation is the

successful decoding of a QR code using QR Sight, a desktop application, directly from raw image data. Secondary evaluation is the successful decoding of an enhanced QR code using a mobile app (Google Goggles or QRReader) following unsuccessful primary evaluation. Enhancement was simply in the form of displaying the captured image on a computer monitor and increasing it in size. No complex processing occurred in this method. Unsuccessful evaluation was declared if neither of the above two methods resulted in a decoded QR code.

4. Analysis Tools

Multiple tools were used for the analysis of captured data in both still image and video formats. MPEG Streamclip (<http://www.squared5.com>) and VLC Player (<http://www.videolan.org>) were used to extract single frames for analysis from videos. MPEG Streamclip produced JPEG and VLC Player produced PNG images, both in the original resolution of the raw video.

Gnu Image Manipulation Program (GIMP; <http://www.gimp.org>) and Adobe Photoshop (<http://www.adobe.com>) were used for post collection image manipulation where necessary. QR Sight (<http://www.appvetica.com>), QRReader (<http://www.tapmedia.co.uk>), Google Goggles (<http://www.google.com/mobile/goggles>), and NeoReader (<http://www.neoreader.com>) were all used for QR decoding. QR Sight is an OS X-based drag and drop QR reading program. QRReader, Google Goggles, and NeoReader are mobile apps for reading QR codes.

B. ANALYSIS METHODS

Simulation and modeling results will compare traditional RF detection and interception probabilities to QR code transmissions to determine the extent to which QR codes are superior. Field experimentation results will be used to compare various technologies to determine the most efficient end-to-end equipment chain in terms of capability, reliability, effectiveness, and cost.

During experimentation, it must be noted that the recognition and decoding of images is dependent on the medium with which it is being displayed. If the QR code is

physically printed, the resolution of the QR code is based on dots per inch (dpi) of the equipment used to print the image. If the QR code is digitally displayed, the resolution of the QR code is based upon the technical specification of that display (i.e. 1080p).

One expected result of the baseline experimentation is a formula to predict successful QR code decoding based on the “crispness” of the display. This will be determined by pixels or dots (dpi) per QR bit.

C. SIMULATION RESULTS

1. Distance Simulation

Distance simulation images were captured as discussed in Chapter V.B.1. The full results are listed in Appendix D. The simulation results show the smallest QR images successfully decoded by each optical device. Each of these values was extrapolated to an equivalent distance based on the size QR code used for field experimentation. Using a reference size of 37 inches by 37 inches and a reference distance of 60 inches, the following ratio relates the simulation results to the extrapolated distance:

$$\text{extrapolated distance} = \frac{\text{reference size}}{\text{simulated size}} \times \text{reference distance}$$

Based on the simulation data, the maximum extrapolated ranges for each imaging device are as follows:

	Still Image Cameras			Video Cameras		
	CCF	Primary Evaluated Range	Secondary Evaluated range	CCF	Primary Evaluated Range	Secondary Evaluated range
	MP x mm	yards	yards	MP x mm	yards	Yards
Digital QR Code Displays	34.2	10.5	24.5	5.0	18.4	24.5
	50.0	13.6	24.5	11.6	21.6	26.3
	1055.0	24.5	61.3			
Printed QR Code Displays	34.2	33.4	52.5	5.0	36.8	52.5
	50.0	33.4	61.3	11.6	36.8	61.3
	506.4	26.3	52.5			

Table 6. Range extrapolation from simulation.

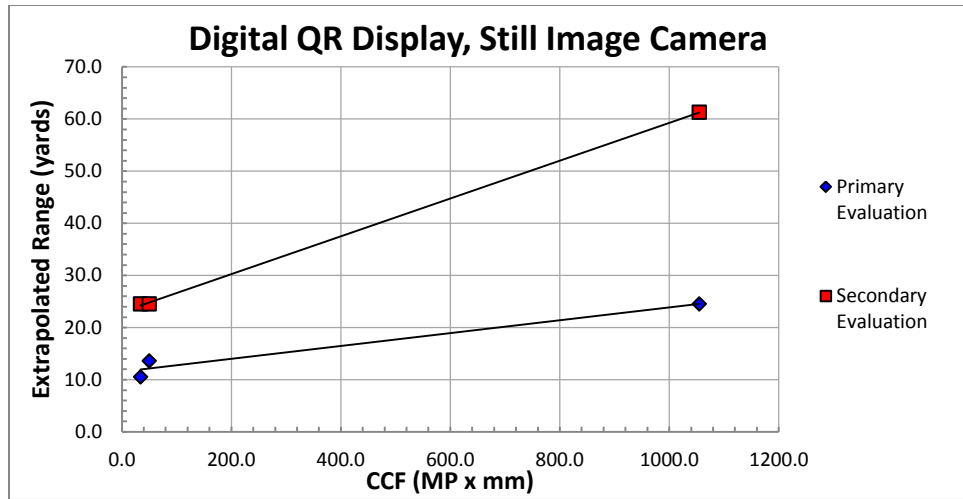

Figure 34. Range extrapolation of simulation data from still image cameras captured from a digitally displayed QR code.

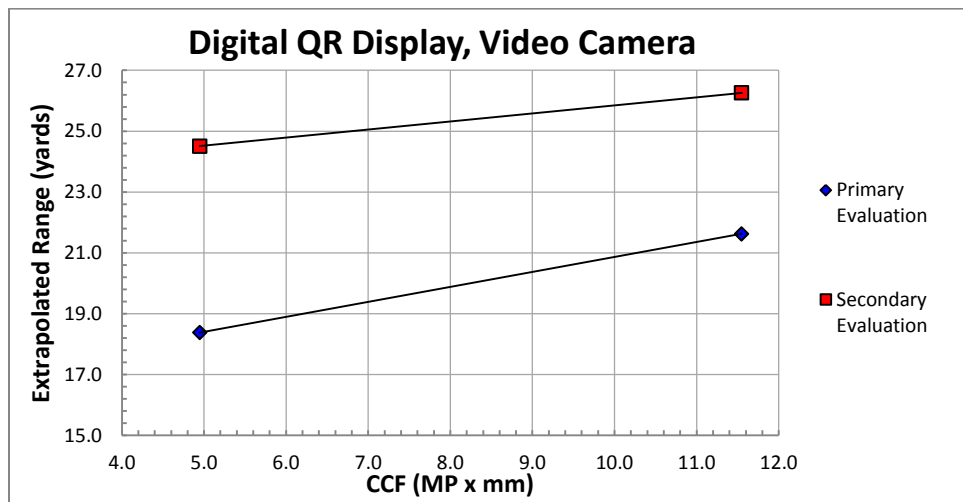

Figure 35. Range extrapolation of simulation data from video cameras captured from a digitally displayed QR code.

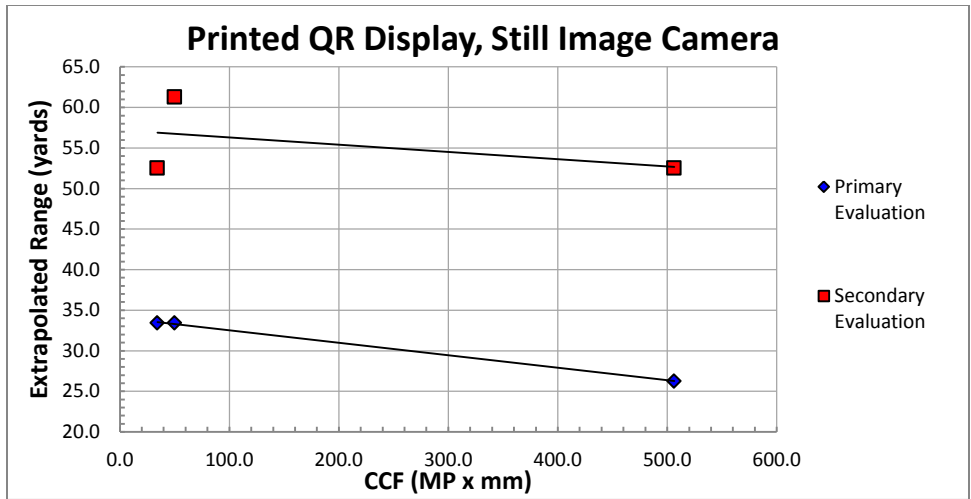

Figure 36. Range extrapolation of simulation data from still image cameras captured from a print displayed QR code.

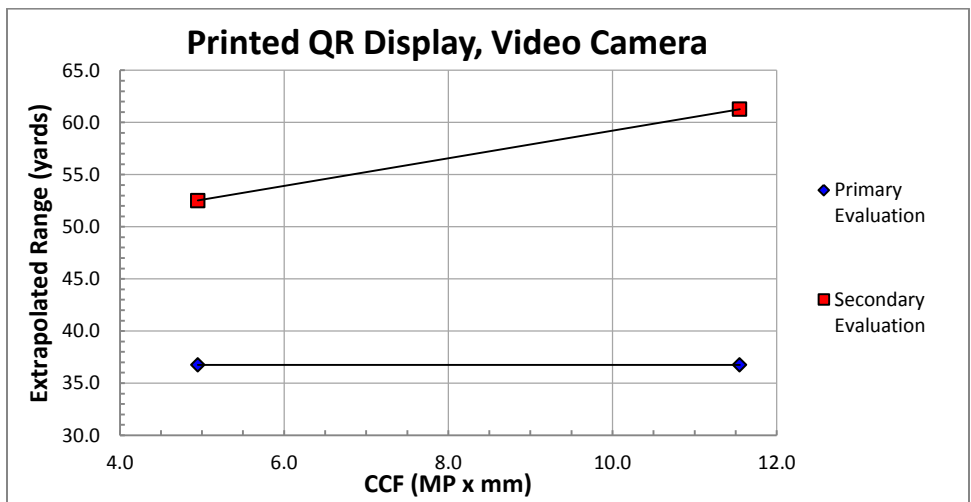

Figure 37. Range extrapolation of simulation data from video cameras captured from a print displayed QR code.

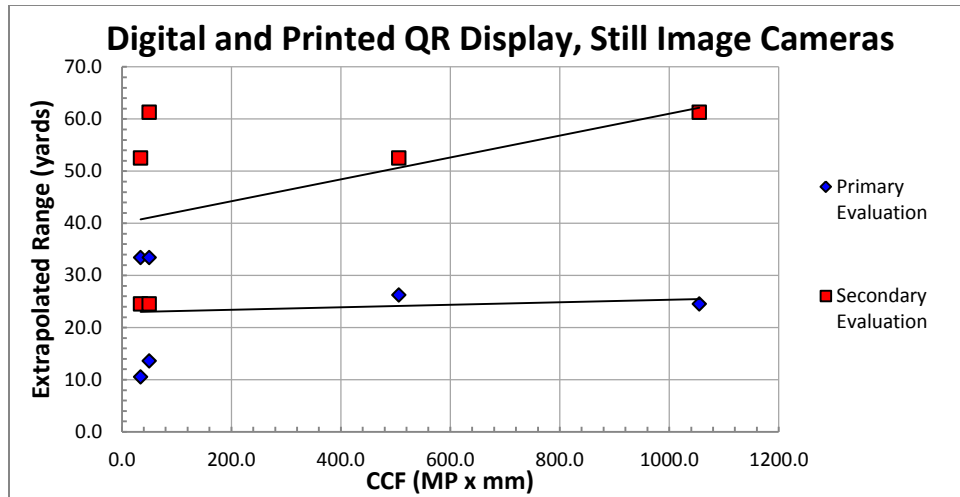

Figure 38. Range extrapolation of simulation data from still image cameras captured from both digital and print displayed QR codes.

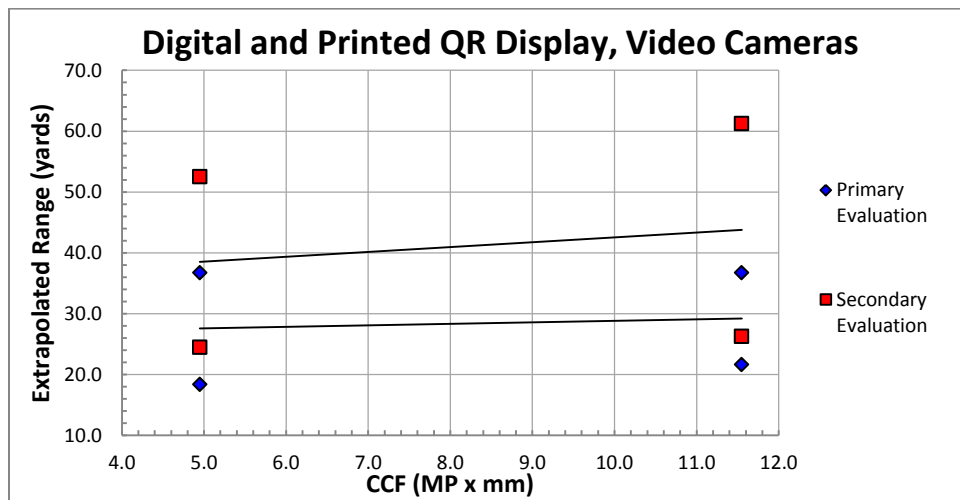

Figure 39. Range extrapolation of simulation data from video cameras captured from both digital and print displayed QR codes.

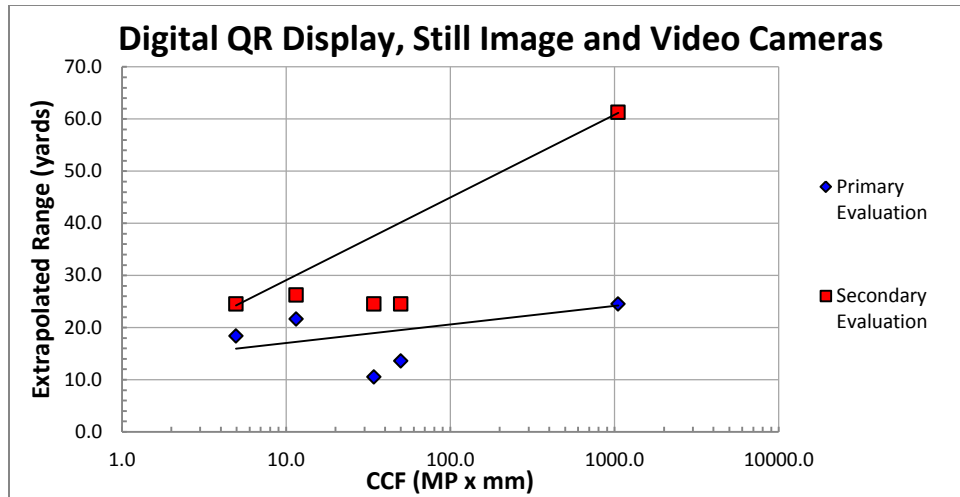

Figure 40. Range extrapolation of simulation data from both still image and video cameras captured from a digitally displayed QR code.

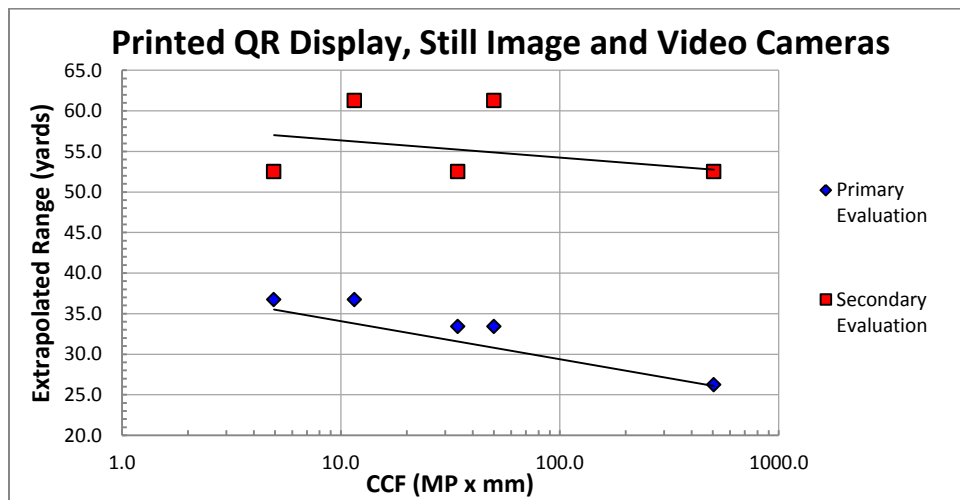

Figure 41. Range extrapolation of simulation data from both still image and video cameras captured from both a print and digitally displayed QR code.

2. Angle Simulation

Angle simulation images were captured as discussed in Chapter V.B.2. The results are as follows:

	Still Image Cameras			Video Cameras		
	CCF	Primary Evaluated Angle	Secondary Evaluated Angle	CCF	Primary Evaluated Angle	Secondary Evaluated Angle
	MP X mm	Degrees	Degrees	MP X mm	Degrees	Degrees
Digital QR Code Displays	34	75	76	5	65	75
	50	60	70	12	68	74
	1055	78	78			
Printed QR Code Displays	34	60	70	5	73	74
	50	55	70	12	42	72
	506	64	70			

Table 7. Maximum off-perpendicular angles of successfully read QR images.

Due to time constraints, full follow-on experimentation of angle analysis was not possible. Because of the implications of field of view (FOV) restrictions on QR code detection, it is important that future work on this research include full angle analysis.

D. FIELD EXPERIMENT (FX) RESULTS

1. Range Determination

Range determination images were captured as discussed in Chapter V.C.1. The full field experiment results are listed in Appendix D. Based on the field experiment data, the maximum ranges for each imaging device are as follows:

Still Image Cameras			Video Cameras		
CCF	Primary Evaluated range	Secondary Evaluated Range	CCF	Primary Evaluated range	Secondary Evaluated Range
MP x mm	yards	yards	MP x mm	yards	yards
34.24	33	67	11.55		42
200	85	85	49.2	22	26
506.4	81	105	52.91	241	284
1793.5	127	207	79.2	130	345
4220	199	428	99.6	34	40
			184.8	442	457

Table 8. Field experiment maximum range results.

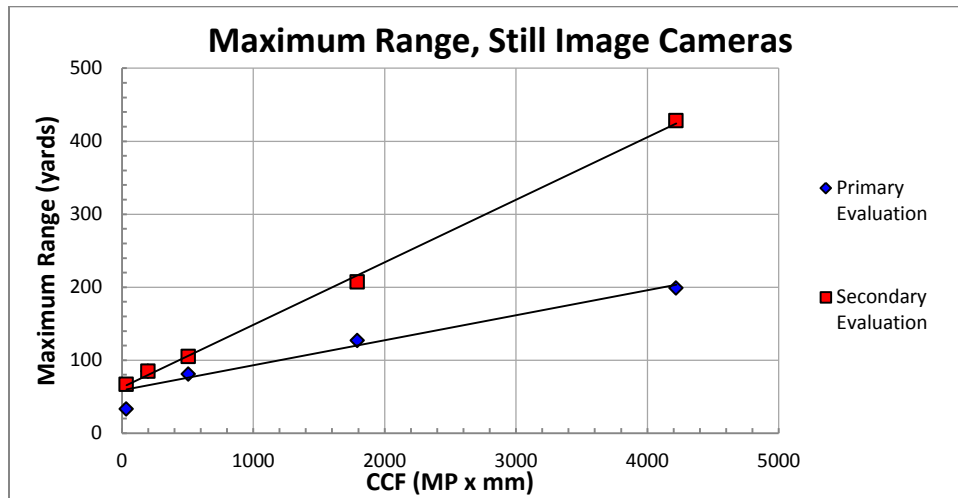

Figure 42. Maximum ranges of successfully read QR codes from images captured from still image cameras.

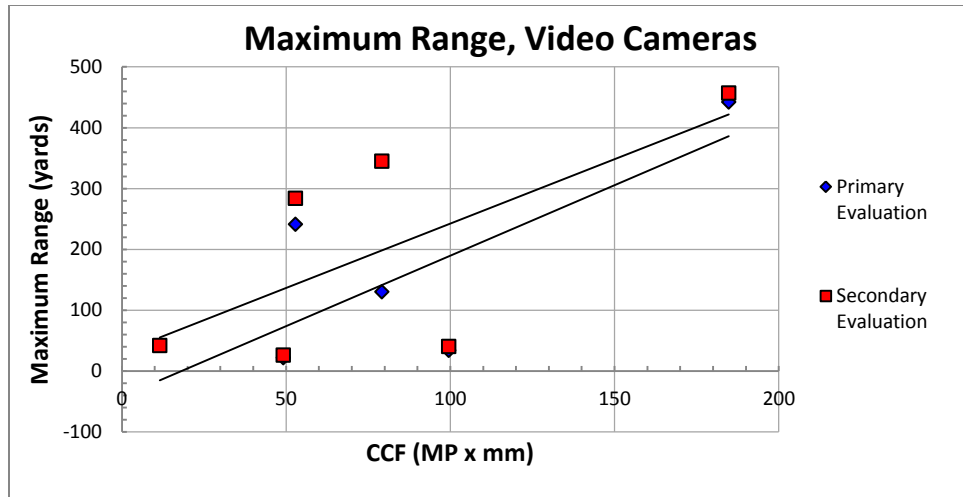

Figure 43. Maximum ranges of successfully read QR codes from images captured from video cameras.

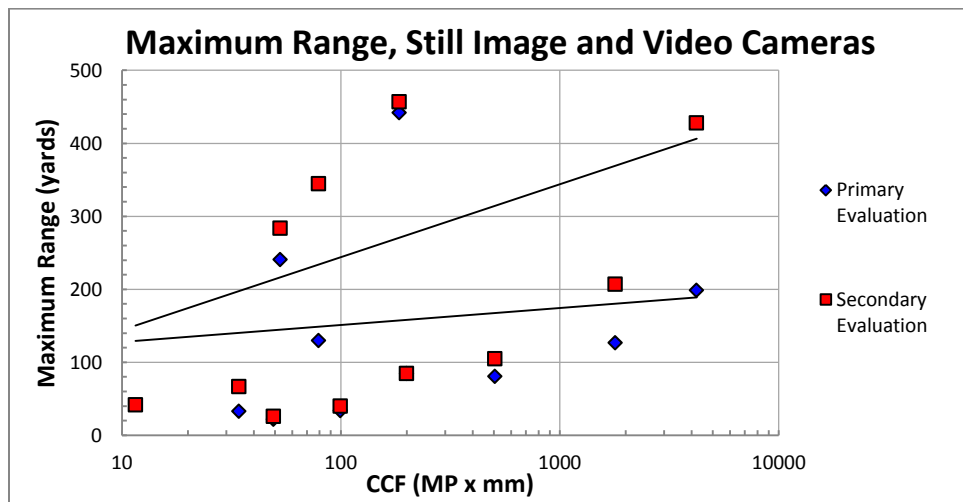

Figure 44. Maximum ranges of successfully read QR codes from images captured from both still image and video cameras.

Extended range testing enabled range evaluation of images captured with a 4K cinematic video camera. This additional field experimentation provided an opportunity to develop an initial image enhancement process as illustrated in Figure 45.



Figure 45. Process steps showing the iterative improvements of a raw captured image resulting in a readable QR code.

In general, if a human can reconstruct a precise QR code from a distorted image, then image-processing software can do as well or better. The unprocessed image is that of a 100 inch X 100 inch QR code displayed at a distance of 750 yards. The transform step simply rotates the QR code to place the finder patterns on the top right, top left and bottom left corners of the image. The white balance stem applies color correction and adjustment to darken the black QR bits and lighten the white space. The warp/perspective step adjusts full and partial image space for any orthogonal inconsistencies restoring the QR code to its known original square state. Edge detection uses a Photoshop and the increased contrast from the white balance step algorithm to discretely define all transitions from black to white. Finally, the difference map is a validation technique that compares the final image to the source image to verify the enhancement process sufficiently reconstructs the QR code.

2. Aircraft and Satellite Demonstration

To date, no images taken by aircraft of the King Hall rooftop QR code have been received. This remains an important area of future work.

Satellite images were captured as discussed in Chapter V.C.2. The resolution of both WorldView-1 and 2 was insufficient to capture imagery of the rooftop QR code with enough clarity for processing by a QR reader. In the case of WorldView-1, reflective light from the white portions of the code washed out the majority of the black portions

making the QR code unrecognizable in general. In the case of WorldView-2, the QR code is distinguishable and the 3 QR bit by 3 QR bit portions of the finder pattern appear clearly in the image. It is presumable, from this data that if 3 x 3 image pixels were captured as a single QR bit, the QR code is likely to be readable. It is possible that if the orientation of the QR bits were aligned with the flight path and sensor patterns of the optical imagers on the satellites, then the individual QR bits appear more distinctly (without aliasing errors) and post-processing image enhancement is more likely to recover the original QR code.

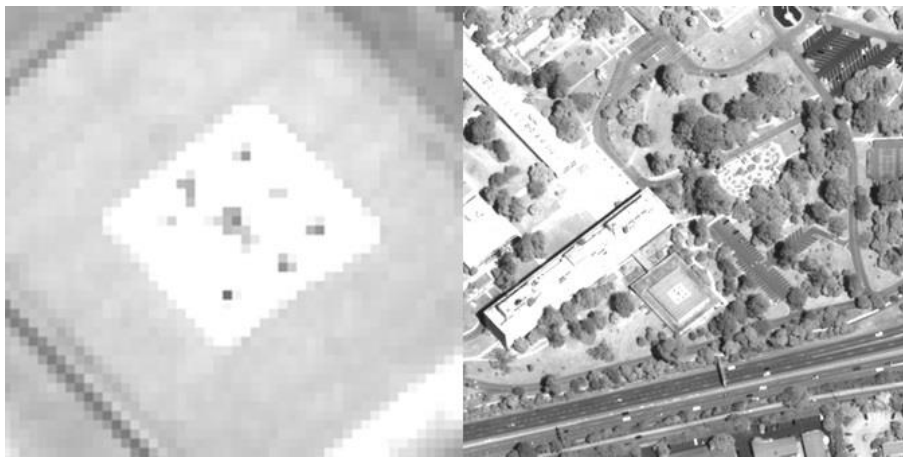

Figure 46. WorldView-1 satellite demonstration imagery (0.5 meter pixel resolution).
Not readable.



Figure 47. WorldView-2 satellite demonstration imagery (0.46 meter pixel resolution).
Not readable.

3. UAV Testing

UAV testing images were captured as discussed in Chapter V.C.3. Because this experiment was a target of opportunity, it was not controlled similarly to the previous experiments. The video captured demonstrated the ability to locate QR codes from a UAV; however the quality was insufficient to provide any readable images without significant image manipulation

E. RESULTS ANALYSIS

1. Simulation Analysis

Figures 48, 49, and 50 represent the predictions of QR code performance based on any combination of resolution and optics in an imaging device. In the case of the still image camera, both prediction lines rise as expected, indicating an increase in performance as the product of sensor resolution and lens size increases. In the case of the video camera, both prediction lines decrease as CCF increases. This is likely due to an insufficient amount of simulated data collected. When both still image and video camera simulation data are combined, the primary prediction line decreases and the secondary prediction line increases as the CCF increases.

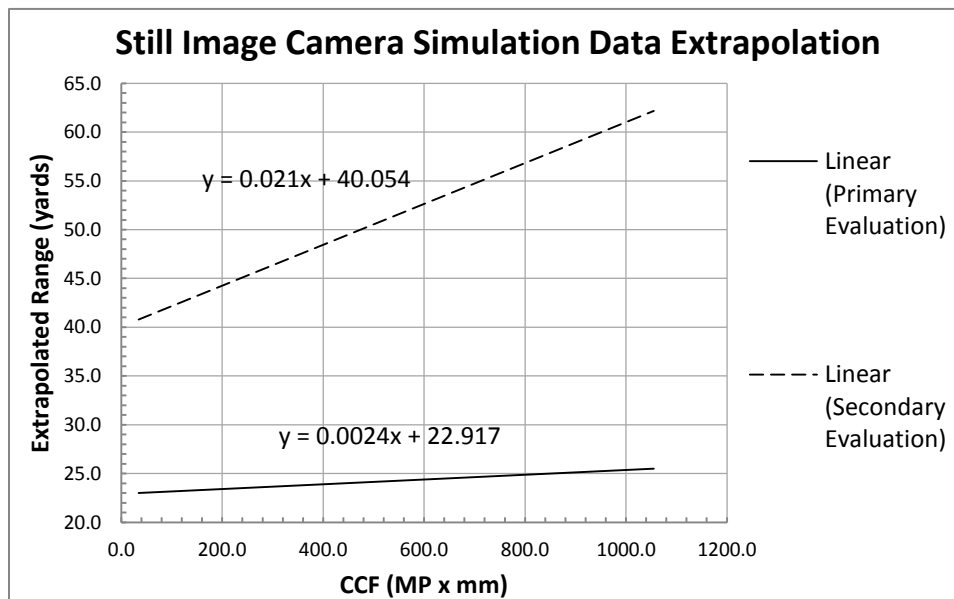

Figure 48. Extrapolation curves from still image camera simulation.

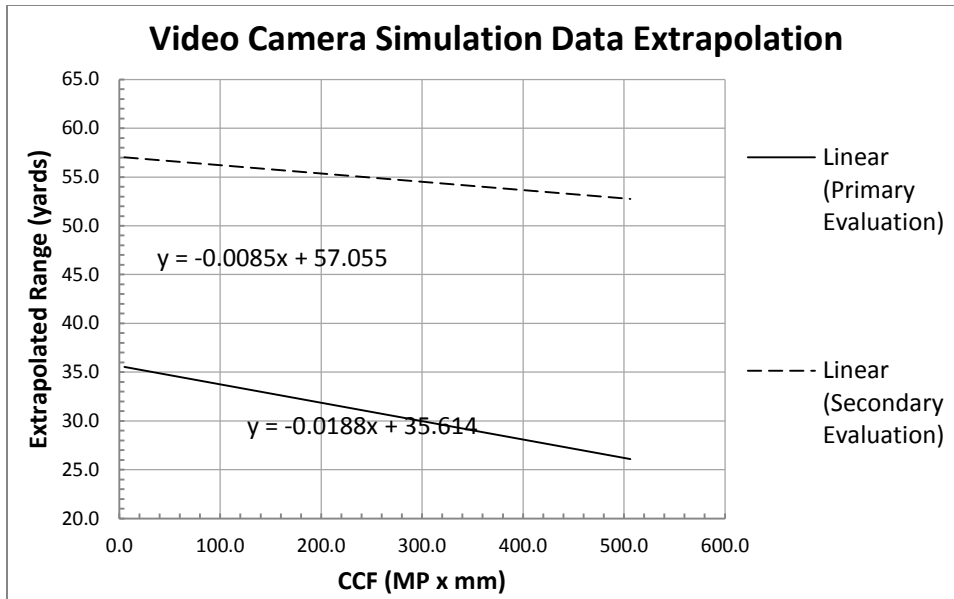

Figure 49. Extrapolation curves from video camera simulation.

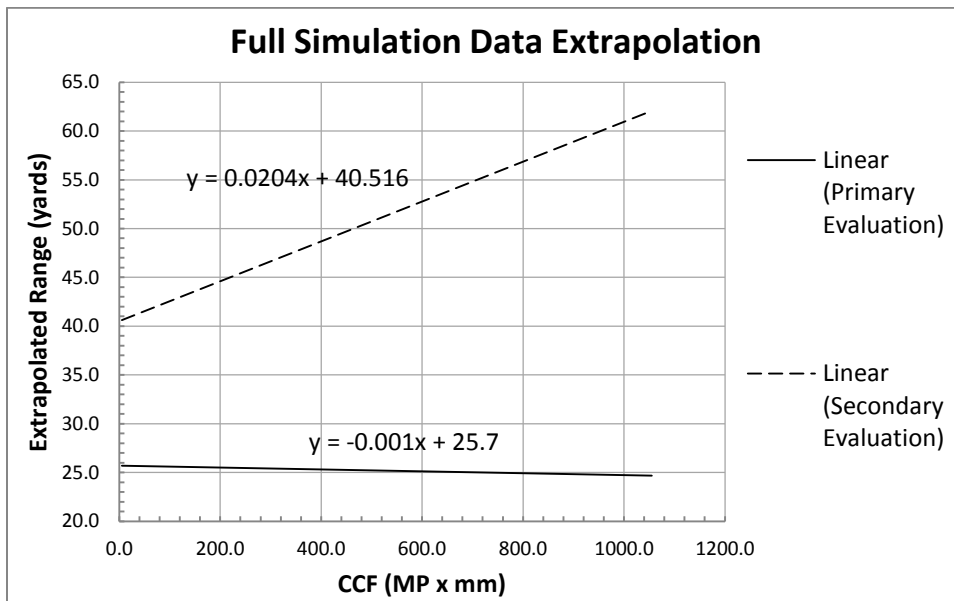

Figure 50. Extrapolation curves from still image and video camera simulations.

In all cases, these prediction curves will benefit from further data collection. In the current state, it is likely that predictions based on these curves will be largely inaccurate. The prediction curves provide the following equations to anticipate the performance of any given lens and sensor combination:

	Primary analysis equation	Secondary analysis equation
Still Image Cameras	$y = 0.021x + 40.054$	$y = 0.0024x + 22.917$
Video Cameras	$y = -0.0085x + 57.055$	$y = -0.0188x + 35.614$
Still Image and Video Cameras	$y = 0.0204x + 40.516$	$y = -0.001x + 25.7$

Table 9. Simulation prediction equations.

2. Field Experiment Validation

The following charts shows extrapolated ranges for all simulation data superimposed on field experiment results. In the case of the still image cameras, the simulation predicted the trends of the field experiment results accurately, but at a differing slope. In the case of the video cameras, the field experiment results were too dispersed to discern a reliable trend. Again, no discernible trends are apparent when both still image and video camera results are combined.

It is important to note, that in all cases, secondary evaluation of QR code images from a given optical device resulted in successful decoding from further distances. Nearly all experimental data met or exceeded preliminary estimates of expected maximum range.

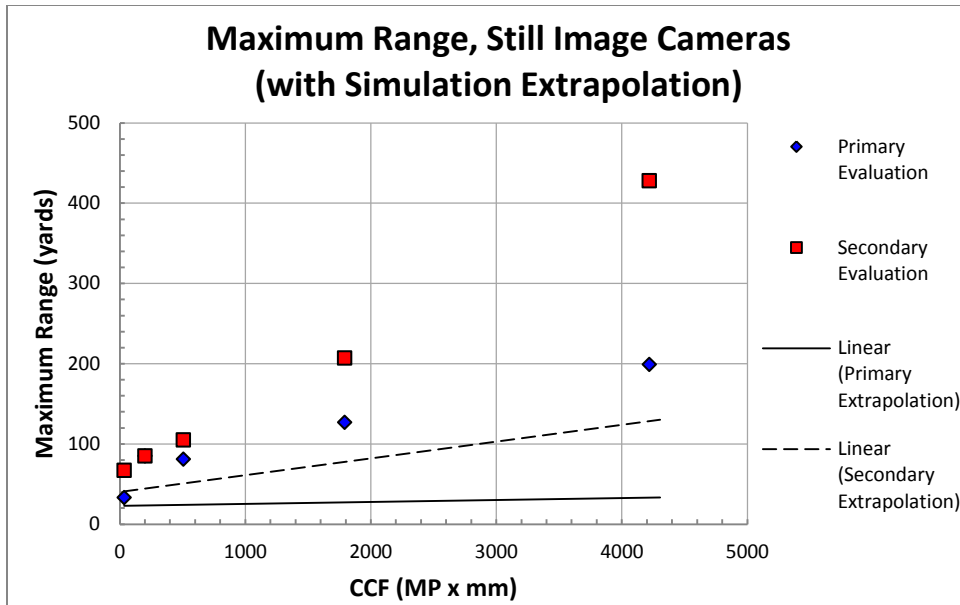

Figure 51. Maximum ranges of successfully read QR codes from images captured from still image cameras superimposed on expected ranges extrapolated from simulation data.

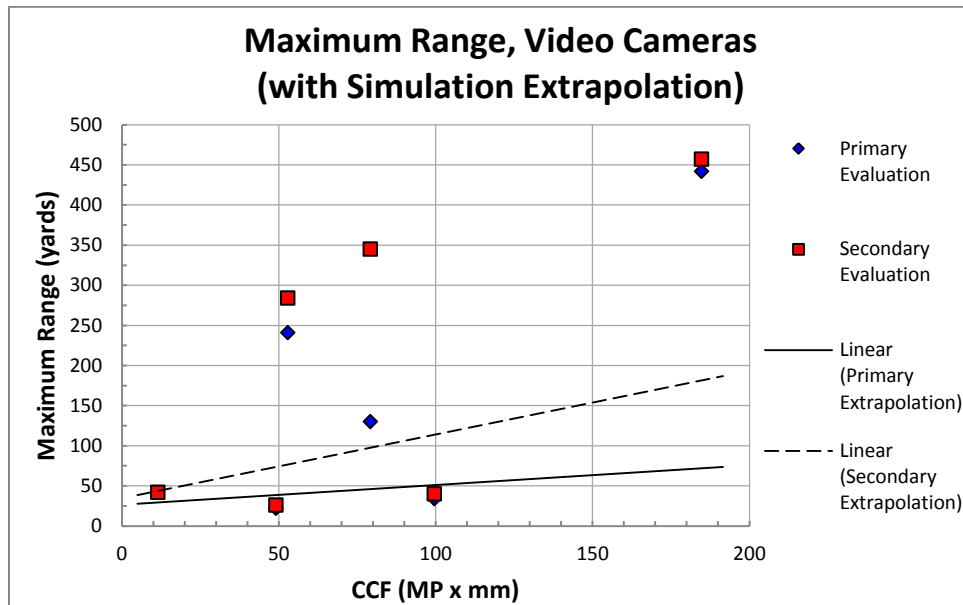

Figure 52. Maximum ranges of successfully read QR codes from images captured from video cameras superimposed on expected ranges extrapolated from simulation data.

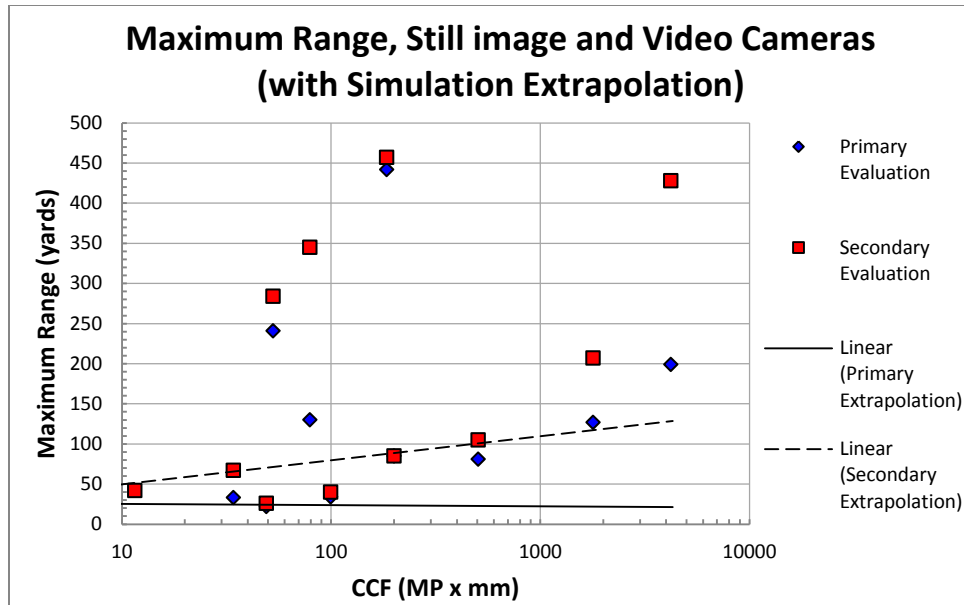

Figure 53. Maximum ranges of successfully read QR codes from images captured from both still image and video cameras superimposed on expected ranges extrapolated from simulation data.

3. Minimum QR Code Sizes

The following charts show the size, in pixels, of the QR bits from images determined to be at the limits of readability. Measurements were taken for both primary evaluation of the raw images by QR Sight and secondary evaluation of the images by mobile QR readers.

Digital Display					
		Primary Evaluation		Secondary Evaluation	
	Camera	Finder Pattern Diagonal (pixels)	QR Bit Size (pixels)	Finder Pattern Diagonal (pixels)	QR Bit Size (pixels)
Still Image Cameras	iPhone 4S	101.9	10.3	44.6	4.5
	Canon SD880	84.9	8.6	45.3	4.6
	Canon 5D MkII	115.3	11.6	38.2	3.9
Video Cameras	JVC HD200	36.1	3.6	26.2	2.6
	JVC HD750	45.3	4.6	35.4	3.6

Table 10. QR bit size, in pixels, from the smallest readable QR code images digitally displayed.

Printed Display					
		Primary Evaluation		Secondary Evaluation	
	Camera	Finder Pattern Diagonal (pixels)	QR Bit Size (pixels)	Finder Pattern Diagonal (pixels)	QR Bit Size (pixels)
Still Image Cameras	iPhone 4S	43.9	4.4	26.9	2.7
	Canon SD880	43.1	4.4	21.2	2.1
	Canon 5D MkII	55.2	5.6	26.9	2.7
Video Cameras	JVC HD200	23.3	2.4	17.0	1.7
	JVC HD750	33.9	3.4	21.2	2.1

Table 11. QR bit size, in pixels, from the smallest readable QR code images print displayed.

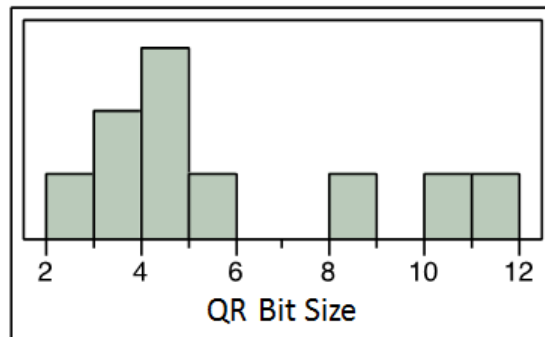

Figure 54. Statistical distribution of QR bit size data from primary evaluation of simulated data ranges.

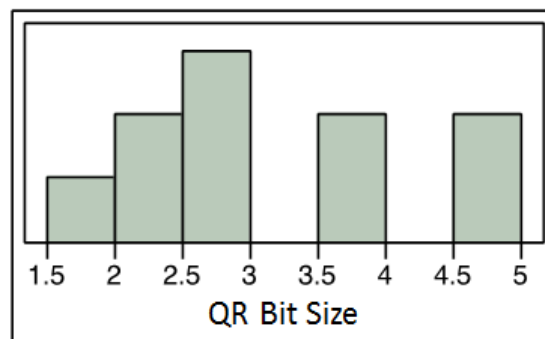

Figure 55. Statistical distribution of QR bit size data from secondary evaluation of simulated range images.

The mean of the primary evaluation results of the simulation data is 5.89 and the mean of the secondary evaluation results of the simulation data is 3.05. This predicts that these values are the minimum sizes, in pixels, of a QR bit in a QR code that can be decoded using QR sight for primary evaluation and mobile QR reader applications for secondary evaluation. The imaging device sample size is small, therefore it is likely that these numbers are inaccurate until more simulation data points can be collected.

	Camera	Primary Evaluation		Secondary Evaluation	
		Finder Pattern Diagonal (pixels)	QR Bit Size (pixels)	Finder Pattern Diagonal (pixels)	QR Bit Size (pixels)
Still Image Cameras	iPhone 4S	38.2	3.9	19.8	2.0
	Canon SD880	55.2	5.6	none	none
	Canon 5D MkII	65.8	6.6	49.5	5.0
		42.8	4.3	26.6	2.7
		61.6	6.2	28.0	2.8
Video Cameras	Canon DC420	27.6	2.8	25.5	2.6
	JVC HD200	78.5	7.9	24.8	2.5
	JVC HD750	none	none	22.6	2.3
		31.1	3.1	28.3	2.9
	HERO3 2.7K	22.6	2.3	19.1	1.9
	HERO3 4K	21.2	2.1	19.1	1.9

Table 12. QR bit size, in pixels, from highest-range readable QR code images

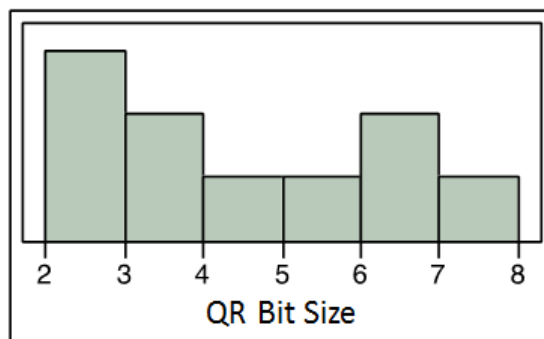

Figure 56. Statistical distribution of QR bit size data from primary evaluation of experimental range images.

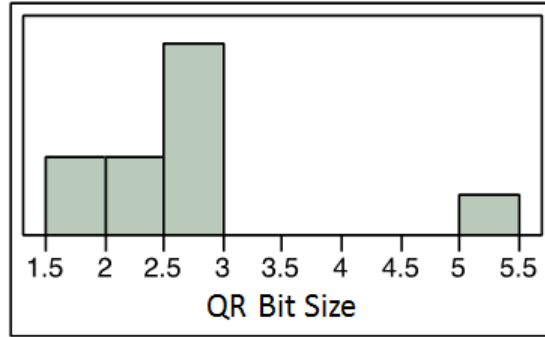

Figure 57. Statistical evaluation of QR bit size data from secondary evaluation of experimental range images.

The mean of the primary evaluation results of the field experiment data is 4.48 and the mean of the secondary evaluation results of the field experiment data is 2.55. The outlier seen in the secondary evaluation of the field results is most likely due to the poor quality of captured images. When compared to the above simulation data, it shows that the simulation estimate provides a more conservative value and that actual results are measurable better than simulated results. Again, the data sample size is small and it is likely that these numbers are inaccurate until more simulation data points can be collected.

One recommendation for QR signaling to satellites is to align the code to be parallel to the expected satellite track direction for maximum overhead resolution when seen from nadir.

Similar to the decoding capability seen with range, in all cases, minimum QR bit size in pixels is smaller when comparing secondary to primary evaluations.

4. QR Code Reconstruction

In Figure 58, an original 4K image is cropped to a single QR bit, revealing that each QR bit occupies a pixel array of 16 x 16. This easily satisfies the minimum requirement of 3 x 3 image pixels. The cropped image is then scaled by 50% in each dimension using a common nearest neighbor (edge preserving) algorithm, and so forth until an approximation of a signal from a standard definition (NTSC VHS) is reached. In the 960 x 480 sample, the pixels that would clamp to black roughly equal the pixels that

would clamp to white, so it is indeterminate. Images below that resolution could not be used to reconstruct a QR bit and therefore not useful to reconstruct a QR code.

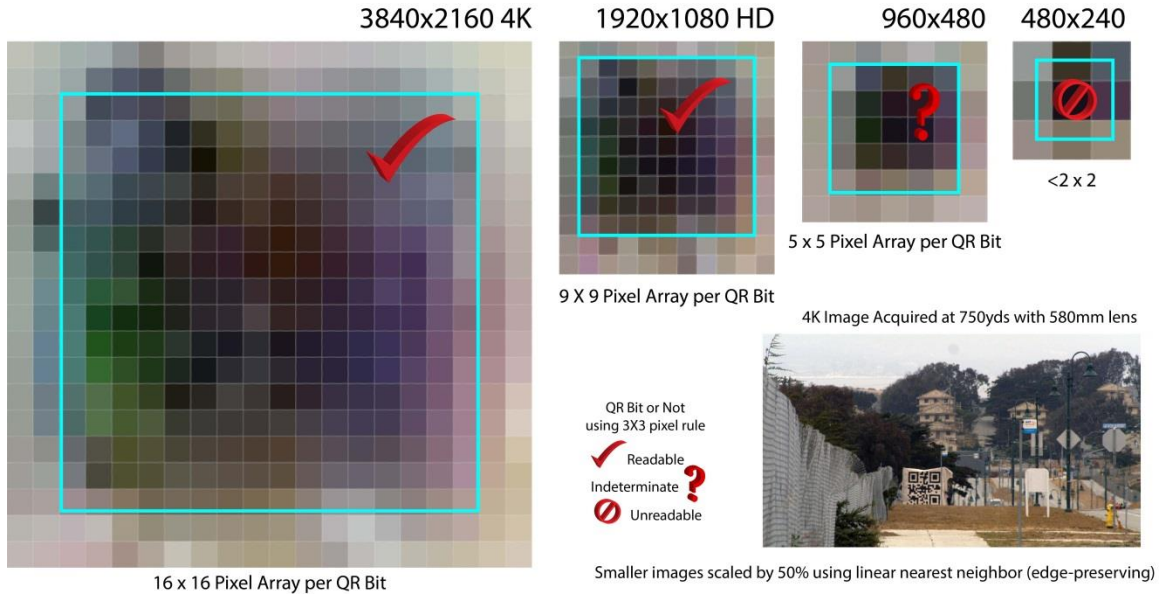

Figure 58. Demonstration of single QR bit reconstruction using 4K video camera image of a 100 inch x 100 inch QR code captured at 750 yards.

QR bits read from 2000 yards returned an approximate 5 x 5 image pixel matrix, though because of optical turbulence, the image is noisy. However, it also satisfies the 3 x 3 image pixel rule. Since optical turbulence is much less of a factor over large bodies of water, it is conceivable that transmission would be successful given focal length (580mm) and 4K sensor size at 2000 yards or more (Frehlich, 1992).

It should be noted that since QR codes are generally constructed of black QR bits on a white background, the de-Bayering, or reconstruction of the signal into a color image is likely unnecessary. Pixels are known to be black in Figure 58; yet because of sensor noise or ambient conditions, they are returned as dark brown or grey. Simple image processing such as clamping values below 50% luma as black and above 50% luma as white would compensate for these anomalies. Other, simple image processing steps are illustrated in Figure 45. Advanced, but still common techniques used in computer vision, such as deriving a histogram of gradient vectors could reconstruct a QR

code from even very noisy images. This is possible because the QR code itself is constructed so that gradient vectors would be highly predictive of QR bit arrangements.

F. QUALITATIVE RESULTS

Based on the vast amount of images captured, it is clear that a rigorous accountability system must be established in order to usefully organize collected data. The initial cataloging proposal for imagery was to superimpose telemetry data over the image. In a tactical environment, however, there may be no way to control the location of the QR code within the captured image. If the code is positioned in the same location as the telemetry data, there is a good chance that the code would be unreadable. Two cataloging alternatives are available: filename structure and embedded meta data.

With filename structure, in-situ image processing would name the image in the file system with appropriate labels to uniquely identify each image as it is captured and stored in memory. Basic labels will be mandatory such as imager identification, geo-location, date and time. A user can then add additional informational tags such as imager resolution, environmental descriptions, operation name, etc. While this method is thorough, long filenames may become cumbersome.

Meta data simplifies complex labeling by appending each file with encoded data that uniquely describes the image. The labeling structure is identical to the filename method, but the labels themselves are stored within the file itself. The filenames then become arbitrary and the internally recorded label data remains unreadable until extracted by an appropriate software interface.

Field experimentation has shown that there is a significant increase in capability when images are processed and enhanced prior to analysis by a QR pattern decoding program. In most cases ranges nearly doubled when images were simply increased in size, displayed on a computer monitor and evaluated with a mobile QR reader application. Further capability increases occurred when the images are enhanced digitally by sharpening the boundaries and increasing the contrast between the black and white QR bits. This is often necessary when lighting conditions are not ideal as the white QR bits tend to shift in color based on the environment. Custom decoding algorithms could be

programmed to incrementally decrease the contrast threshold required for detecting QR codes when a code is not initially detected in an image.

G. CHAPTER SUMMARY

This chapter discussed the results of both simulation and field experiments in order to determine the effectiveness of the various technologies available for detection and decoding of QR codes at longer distances. The most common trend encountered is that of increased capability as the focal length and or resolution of the imaging device increases. Additionally, the introduction of post processing of QR code images drastically increased decoding performance.

THIS PAGE INTENTIONALLY LEFT BLANK

VII. CONCLUSIONS AND RECOMMENDATIONS

A. FINDINGS AND CONCLUSIONS

The results of this research show that there is significant merit to determining the threshold of the capability of current camera technology to read QR codes at distance. The trends established show that it is likely that QR codes can be read at distances great enough to make them useful for a tactical situation. When considering the technical factor, it is clear that its increase, either through resolution or lensing, can increase the range capability of that equipment. These two technologies, image sensor resolution and lensing, have the largest effect on QR code performance. One item that was clear regardless of sensor resolution and optics employed is that a progressively-displayed QR code always produced a superior image for decoding when compared to an interlaced image.

While the range barrier to success is still significant, secondary analysis methods assist greatly in mitigating this deficit. A digital increase in size alone significantly increases the range capability of a given imaging device. Software enhancement of image characteristic pushes this capability even further. For example, software can increase the contrast between QR bits and eliminate angular distortion. The option of replacing a full size QR code with a MicroQR may help extend the range of success by increasing the size of an individual QR bit for a given display space (International Organization of Standards, 2006, September 01).

Further experimentation and software development is warranted and remains quite promising. Once a full tactical decision aid (TDA) is completed, it can enable deployed military personnel and systems to confidently select field technology without rigorous experimentation.

With the extent of this research, tactical applications of QR code communications are limited. Range is limited to approximately 500 yards and both the QR code display and the camera must remain still. As further technology is tested, it is likely that the viable maximum range is increased significantly and a measure of relative motion between the display and the imager becomes acceptable.

Immediate future work should refine the simulation charts by testing a larger number of imaging sensors with a wider variety of lenses. Following this, the simulation must be validated by collecting field data to confirm the expected capability ranges. If the field results and simulation results correspond, performance values need to be predicted for imager/lens combinations not included in the simulation or experiment in order to further validate the simulation.

B. RECOMMENDATIONS FOR FUTURE WORK

1. Simulation and Testing

a. Angle Validation

Validate data collected during angle simulation experiment. This validation experiment attempts to determine at which angles the QR code can be read without image enhancement or extra processing. Additional angular experiments need to be conducted to determine if distance has an effect on the maximum angle at which a QR code can be read and decoded.

Digital displays have a non-linear drop-off response when viewed from an angle off of the perpendicular axis and are therefore difficult to see when viewed from extreme angles. This is especially true for older technologies. This experiment might be best performed using both a digital display and a printed display in an attempt to determine if angular viewing is affected by the characteristics of a digital display.

b. Realistic Environment Testing

Assuming an appropriate range for QR code communications can be achieved for tactical employment, additional testing must occur to ensure it is suitable in the various environments in which it may be used. During this research, many of the captured images were blurry or distorted due to relative motion between the QR code display and the imaging device, rendering them unusable. High-frame-rate progressive-scanning equipment need to be tested to verify that motion in a tactical environment can be accounted for. Cameras that debayer (or reconstruct a viewable image from sensor data) as full frames in a progressive, line-by-line fashion with no interlacing of scan lines

(e.g. 1080i), no inter-frame compression, no intra-frame compression, and when combined with an electronic shutter provide a major advantage. Such camera systems can *freeze-frame* fast-moving objects, thus removing motion blur induced by camera movement or by fast-moving objects. When the electronic shutter operates at multiples of the progressive frame scan, this also nearly eliminates camera blur induced by the shutter, providing clear images at extremely high frame rates. Thusly, digital cinema cameras are more suitable for exploitation as they have progressive scan, provide full frames and employ electronic shutters at varying speeds. The advantage provided by these cameras is significant and testing should concentrate on these devices.

The following are a few examples of environments that should be examined. Ship-to-ship QR code communications during a high sea state must account for relative motion between the code and the camera in all three dimensions and occasional obstruction due to swells and wave splash. Underwater QR code communication might be possible at short ranges and must overcome low light intensities and potential scintillation due to suspended particulate matter. Tagging of mine-like objects with QR codes might provide usefully detailed marking. Aircraft QR code communications and close proximity must account for a high transverse rate of speed between the code and the imager. Tactical ground units in a desert environment may have to use QR codes in a dust or sand storm which causes obstruction much of the time.

Further environmental testing with respect to airport safety operations can be conducted in order to reduce aircraft incidents prior to takeoff (Sokol, 2013).

c. Aircraft QR Code Detection

Experiments should be conducted to ensure that a QR code affixed to the bottom of an aircraft wing can be read from a ground station and that the aircraft can read a fixed QR code on the ground. It is likely that a QR code on an aircraft body that is dark relative to its background will not have sufficient contrast to QR code reading software for successful detection and decoding.

This area of study is ideal to develop synthetic aperture QR displays in which a matrix is progressively constructed over a finite period of time. For instance, a

single row of pixels may be affixed to the underside of an aircraft wing and programmed to display each row of a QR code at fixed intervals. As this row of pixels crosses the FOV of an imaging device, the timing of each frame is synchronized such that the full QR code is constructed in the final image.

d. Streaming QR Code Communication

The ability to stream QR codes immensely increases the amount of data that can be communicated via QR codes. Continuing experiments need to be conducted to test the ability to link together QR codes in a streaming fashion, capture streaming QR codes, and fully decode the data stream.

2. Software

a. QR Code Detection Capabilities

Many open-source QR reading programs lose all functionality if the finder patterns for multiple QR codes exist in a single image. Software should be developed such that it can detect and distinguish between all valid QR codes in a single image.

Dynamic scanning routines should be developed so that a QR code image can be detected in a complex environment. If obfuscation methods are implemented in tactical environments, it is critical for the detection routine to be able to distinguish the QR code from the rest of the image. Current QR code readers search for the QR finder pattern, but alternate patterns may prove to be more recognizable and thus reliable.

Image-enhancing programs sharpen, color correct, and increase contrast levels in images. Adaptive QR code detection and reading refers to the image characteristic requirements for detecting codes. For instance, if a system requires a sharp contrast between black and white QR bits and does not detect a code, the contrast requirement may be relaxed until a code is found or until a minimum threshold is reached. The further such requirements are relaxed, however, the lower the confidence in a decoded message becomes.

b. Metadata and Cataloging

Due to the anticipated large volume of image files that are collected by a QR code communication system, a rigorous method for naming, storing and accessing files must be established. The tactical and technical requirements must be determined for meta data and name-value pairs must be implemented into the system.

Data collection plans must be defined in which file naming and storage plans are specified. The file structure must include unambiguous locations for grouped images and must be able to identify post-processed files that correspond to each raw image.

c. Software Interface Development

A complete interface must be designed and developed to provide the user full control over transmitted and received messages. All factors in the Tactical QR Code Signaling Dataflow diagram (Figure 5) must be accounted for.

Primary functionality must provide the user with an operating envelope in which successful QR code communications is anticipated. This operating envelope is generated using multiple inputs such as visibility, sea state, equipment details and illumination.

3. Technology

How do various technologies impact the ability to achieve superior performance in QR code communications? When considering cameras, it should be determined whether certain types of cameras perform better, such as CMOS, CCD, CID and analog. When considering displays, studies should focus on the difference between types such as liquid-crystal, light-emitting diode, and plasma. Printed displays should be considered for comparison as well as the Kindle Paperwhite technology.

4. Security

Methods of obfuscation to prevent unauthorized users for detecting or reading QR codes should be thoroughly explored. While encryption can never be eliminated from

classified transmission, lower levels of encryption would reduce the overhead required to secure a message.

Removal or replacement of standard finder patterns with proprietary patterns renders all open-source QR readers ineffective with respect to this system of communications.

Intentional errors can be placed within a code that, when removed from the code can be reconstructed to form the message truly intended to be sent.

All or a portion of the QR bits can be inverted such that the intended recipient is the only user who knows where to revert the bits back to their original state for decoding.

APPENDIX A—QR CODE WIKIPEDIA

Wikipedia is an online open-content collaborative encyclopedia; that is, a voluntary association of individuals and groups working to develop a common resource of human knowledge. The structure of the project allows anyone with an Internet connection to alter its content. Please be advised that nothing found here has necessarily been reviewed by people with the expertise required to provide you with complete, accurate or reliable information.

That is not to say that you will not find valuable and accurate information in Wikipedia; much of the time you will. However, Wikipedia cannot guarantee the validity of the information found here. The content of any given article may recently have been changed, vandalized or altered by someone whose opinion does not correspond with the state of knowledge in the relevant fields. (Wikipedia, n.d.)

The remainder of this appendix is taken directly from the QR Code Wikipedia page (http://en.wikipedia.org/wiki/QR_code, 14 May 2013). It is a non-standard reference and is included in the interest of completeness for the reader to understand the capabilities of QR code technology. By no means is this intended to be a de-facto reference for the development, implementation, or operation of an optical QR code communication system. It is provided here as a user reference.

QR code

QR code (abbreviated from **Quick Response Code**) is the trademark for a type of matrix barcode (or two-dimensional barcode) first designed for the automotive industry in Japan; a barcode is an optically machine-readable label that is attached to an item and that records information related to that item: The information encoded by a QR code may be made up of four standardized types ("modes") of data (numeric, alphanumeric, byte / binary, Kanji) or, through supported extensions, virtually any type of data.^[1]

Recently, Wikipedia:Manual of Style/Dates and numbers#Chronological items the QR Code system has become popular outside the automotive industry due to its fast readability and greater storage capacity compared to standard UPC barcodes; applications include product tracking, item identification, time tracking, document management, general marketing, and much more.^[1]

A QR code consists of black modules (square dots) arranged in a square grid on a white background, which can be read by an imaging device (such as a camera) and processed using Reed-Solomon error correction until the image can be appropriately interpreted; data is then extracted from patterns present in both horizontal and vertical components of the image.^[1]

Invention

The QR code system was invented in 1994 by Toyota's subsidiary, Denso Wave. Its purpose was to track vehicles during manufacture; it was designed to allow high-speed component scanning.^[1] It has since become one of the most popular types of two-dimensional barcodes.^[1]

Standards

There are several standards that cover the encoding of data as QR codes:^[1]

- October 1997 – AIM (Association for Automatic Identification and Mobility) International^[2]
- January 1999 – JIS X 0510
- June 2000 – ISO/IEC 18004:2000 *Information technology – Automatic identification and data capture techniques – Bar code symbology – QR code*^[3] (now withdrawn)

Defines QR code models 1 and 2 symbols.



QR code for the URL of the English Wikipedia Mobile main page, "<http://en.m.wikipedia.org>"



Telephone directory with QR code on the cover

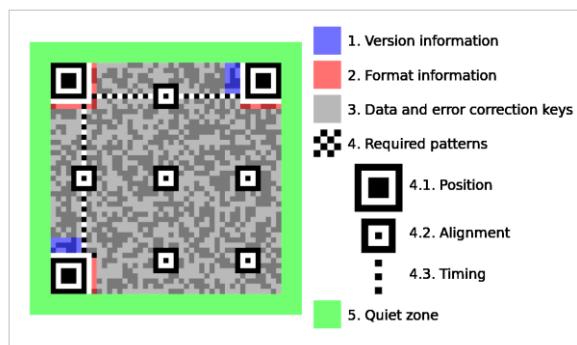

- 1 September 2006 – ISO/IEC 18004:2006 *Information technology – Automatic identification and data capture techniques – QR code 2005 bar code symbology specification*^[4]
Defines QR code 2005 symbols, an extension of QR code model 2. Does not specify how to read QR code model 1 symbols, or require this for compliance.

At the application layer, there is some variation between most of the implementations. Japan's NTT DoCoMo has established de facto standards for the encoding of URLs, contact information, and several other data types.^[5] The open-source "ZXing" project maintains a list of QR code data types.^[6]

Uses

Originally designed for industrial uses, QR codes have become common in consumer advertising. Typically, a smartphone is used as a QR-code scanner, displaying the code and converting it to some useful form (such as a standard URL for a website, thereby obviating the need for a user to type it manually into a web browser).

"In the shopping industry, knowing what causes the consumers to be motivated when approaching products by the use of QR codes, advertisers and marketers can use the behavior of scanning to get consumers to buy, causing it to have the best impact on ad and marketing design."^[7] As a result, the QR code has become a focus of advertising strategy, since it provides quick and effortless access to the brand's website.^{[8][9]} Beyond mere convenience to the consumer, the importance of this capability is that it increases the conversion rate (that is, increases the chance that contact with the advertisement will convert to a sale), by coaxing qualified prospects further down the conversion funnel without any delay or effort, bringing the viewer to the advertiser's site immediately, where a longer and more targeted sales pitch may continue.

Although initially used to track parts in vehicle manufacturing, QR codes are now (as of 2012^[10]) used over a much wider range of applications, including commercial tracking, entertainment and transport ticketing, product/loyalty marketing (examples: mobile couponing where a company's discounted and percent discount can be captured using a QR code decoder which is a mobile app, or storing a company's information such as address and related information alongside its alpha-numeric text data as can be seen in Yellow Pages directory), and in-store product labeling. It can also be used in storing personal information for use by government. An example of this is Philippines National Bureau of Investigation (NBI) where NBI clearances now come with a QR code. Many of these applications target mobile-phone users (via mobile tagging). Users may receive text, add a vCard contact to their device, open a Uniform Resource Identifier (URI), or compose an e-mail or text message after scanning QR codes. They can generate and print their own QR codes for others to scan and use by visiting one of several pay or free QR code-generating sites or apps. Google has a popular API to generate QR codes,^[11] and apps for scanning QR codes can be found on nearly all smartphone devices.^[12]

QR codes storing addresses and Uniform Resource Locators (URLs) may appear in magazines, on signs, on buses, on business cards, or on almost any object about which users might need information. Users with a camera phone equipped with the correct reader application can scan the image of the QR code to display text, contact information, connect to a wireless network, or open a web page in the telephone's browser. This act of linking from physical world objects is termed *hardlinking* or *object hyperlinking*. QR codes also may be linked to a location to track where a code has been scanned. Either the application that scans the QR code retrieves the geo information by using GPS and cell tower triangulation (aGPS) or the URL encoded in the QR code itself is associated with a location.^[1]

In June 2011, The Royal Dutch Mint (Koninklijke Nederlandse Munt) issued the world's first official coin with a QR code to celebrate the centennial of its current building and premises. The coin was able to be scanned by a smartphone and link to a special website with contents about the historical event and design of the coin.^[14] In 2008, a Japanese stonemason announced plans to engrave QR codes on gravestones, allowing visitors to view information about the deceased, and family members to keep track of visits.^[15]



Mobile operating systems

QR codes can be used in Google's Android operating system and iOS devices (iPhone/iPod/iPad), as well as by using Google Goggles, 3rd party barcode scanners, and the Nintendo 3DS. The browser supports URL redirection, which allows QR codes to send metadata to existing applications on the device. mbarcode^[16] is a QR code reader for the Maemo operating system. In Apple's iOS, a QR code reader is not natively included, but more than fifty paid and free apps are available with both the ability to scan the codes and hard-link to an external URL. Google Goggles is an example of one of many applications that can scan and hard-link URLs for iOS and Android. With BlackBerry devices, the App World application can natively scan QR codes and load any recognized Web URLs on the device's Web browser. Windows Phone 7.5 is able to scan QR codes through the Bing search app.

URLs

URLs aided marketing conversion rates even in the pre-smartphone era but during those years faced several limitations: ad viewers usually had to type the URL and often did not have a web browser in front of them at the moment they viewed the ad. The chances were high that they would forget to visit the site later, not bother to type a URL, or forget what URL to type. Friendly URLs decreased these risks but did not eliminate them. Some of these disadvantages to URL conversion rates are fading away now that smartphones are putting web access and voice recognition in constant reach. Thus an advert viewer need only reach for his or her phone and speak the URL, at the moment of ad contact, rather than remember to type it into a PC later.^[1]

Virtual stores

During the month of June 2011, according to one study, 14 million mobile users scanned a QR code or a barcode. Some 58% of those users scanned a QR or barcode from their homes, while 39% scanned from retail stores; 53% of the 14 million users were men between the ages of 18 and 34.^[17] The use of QR codes for "virtual store" formats started in South Korea,^[18] and Argentina,^[19] but is currently expanding globally.^[20] Big companies such as Walmart, Procter & Gamble and Woolworths have already adopted the Virtual Store concept.^[21]

Code payments

QR codes can be used to store a bank account information or a credit card information, or they can be specifically designed to work with particular payment provider applications. There are several trial applications of QR code payments across the world.^{[22][23]}

In November 2012, QR code payments were deployed on a larger scale in the Czech Republic when an open format for payment information exchange - a Short Payment Descriptor - was introduced and endorsed by the Czech Banking Association as the official local solution for QR payments.^[24]

Website login

QR codes can be used to log in into websites: a QR Code is shown on the login page on a computer screen, and when a registered user scans it with a verified smartphone, they will automatically be logged in on the computer. Authentication is performed by the smartphone which contacts the server. A QR code login method called "Sesame" was trialled by Google in January 2012.^[25]

Design

Unlike the older, one-dimensional barcode that was designed to be mechanically scanned by a narrow beam of light, a QR code is detected by a 2-dimensional digital image sensor and then digitally analyzed; the analyzer locates the three distinctive squares at the corners of the QR code, using a smaller square near the fourth corner to normalize the image for size, orientation, and angle of viewing. The small dots throughout the QR code are then converted to binary numbers and validated with an error-correcting code.

Storage

The amount of data that can be stored in the QR code symbol depends on the datatype (*mode*, or input character set), version (1, ..., 40, indicating the overall dimensions of the symbol), and error correction level. The maximum storage capacities occur for 40-L symbols (version 40, error correction level L).^{[1][26]}

Maximum character storage capacity (40-L)

character refers to individual values of the input mode/datatype

Input mode	max. characters	bits/char	possible characters, default encoding
Numeric only	7,089	3 $\frac{1}{8}$	0, 1, 2, 3, 4, 5, 6, 7, 8, 9
Alphanumeric	4,296	5 $\frac{1}{2}$	0–9, A–Z (upper-case only), space, \$, %, *, +, -, ., /, :
Binary/byte	2,953	8	ISO 8859-1
Kanji/kana	1,817	13	Shift JIS X 0208

Here are some sample QR code symbols:



Encryption

Encrypted QR codes, which are not very common, have a few implementations. An Android app,^[27] for example, manages encryption and decryption of QR codes using the DES algorithm (56 bits).^[28] The Japanese immigration system uses encrypted QR codes when issuing visa in passports^[29] as shown in the figure here.



Error correction

Codewords are 8 bits long and use the Reed–Solomon error correction algorithm with four error correction levels. The higher the error correction level, the less storage capacity. The following table lists the approximate error correction capability at each of the four levels:



Damaged but still decodable QR code

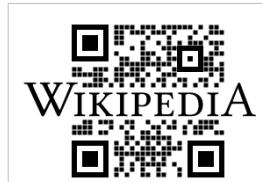

Example of a QR code with artistic embellishment that will still scan correctly thanks to error correction.

Level L (Low)	7% of codewords can be restored.
Level M (Medium)	15% of codewords can be restored.
Level Q (Quartile) ^[30]	25% of codewords can be restored.
Level H (High)	30% of codewords can be restored.

In larger QR symbols, the message is broken up into several Reed–Solomon code blocks. The block size is chosen so that at most 15 errors can be corrected in each block; this limits the complexity of the decoding algorithm. The code blocks are then interleaved together, making it less likely that localized damage to a QR symbol will overwhelm the capacity of any single block.

Thanks to error correction, it is possible to create artistic QR codes that still scan correctly, but contain intentional errors to make them more readable or attractive to the human eye, as well as to incorporate colors, logos, and other features into the QR code block.^{[31][32]}

Encoding

The format information records two things: the error correction level and the mask pattern used for the symbol. Masking is used to break up patterns in the data area that might confuse a scanner, such as large blank areas or misleading features that look like the locator marks. The mask patterns are defined on a grid that is repeated as necessary to cover the whole symbol. Modules corresponding to the dark areas of the mask are inverted. The format information is protected from errors with a BCH code, and two complete copies are included in each QR symbol.^[1]

The message data is placed from right to left in a zigzag pattern, as shown below. In larger symbols, this is complicated by the presence of the alignment patterns and the use of multiple interleaved error-correction blocks.

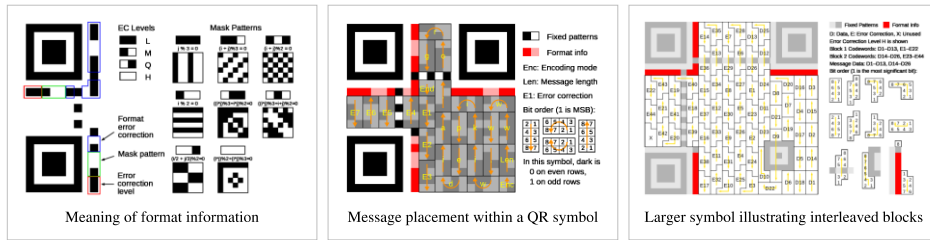

Four-bit indicators are used to select the encoding mode and convey other information. Encoding modes can be mixed as needed within a QR symbol.

Encoding modes

Indicator	Meaning
0001	Numeric encoding (10 bits per 3 digits)
0010	Alphanumeric encoding (11 bits per 2 characters)
0100	Byte encoding (8 bits per character)
1000	Kanji encoding (13 bits per character)
0011	Structured append (used to split a message across multiple QR symbols)
0111	Extended Channel Interpretation (select alternate character set or encoding)
0101	FNC1 in first position (see Code 128 for more information)
1001	FNC1 in second position
0000	End of message

After every indicator that selects an encoding mode is a length field that tells how many characters are encoded in that mode. The number of bits in the length field depends on the encoding and the symbol version.

Number of bits per length field

Encoding	Ver. 1–9	10–26	27–40
Numeric	10	12	14
Alphanumeric	9	11	13
Byte	8	16	16
Kanji	8	10	12

Alphanumeric encoding mode stores a message more compactly than the byte mode can, but cannot store lower-case letters and has only a limited selection of punctuation marks, which are sufficient for most web addresses. Two characters are coded in an 11-bit value by this formula:

$$V = 45 \times C_1 + C_2$$

Alphanumeric character codes

Code	Character	Code	Character	Code	Character	Code	Character	Code	Character
00	0	09	9	18	I	27	R	36	SP
01	1	10	A	19	J	28	S	37	\$
02	2	11	B	20	K	29	T	38	%
03	3	12	C	21	L	30	U	39	*
04	4	13	D	22	M	31	V	40	+
05	5	14	E	23	N	32	W	41	-
06	6	15	F	24	O	33	X	42	.
07	7	16	G	25	P	34	Y	43	/
08	8	17	H	26	Q	35	Z	44	:

Decoding example

The following images offer more information about the QR code.

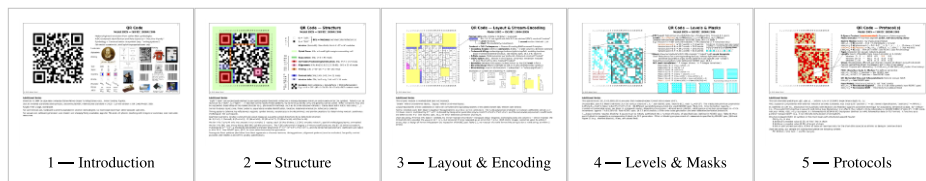

License

The use of QR codes is free of any license. The QR code is clearly defined and published as an ISO standard.

Denso Wave owns the patent rights on QR codes, but has chosen not to exercise them.^[1] In the USA, the granted QR code patent is US 5726435^[33], and in Japan JP 2938338^[34]. The European Patent Office granted patent "EPO 0672994"^[35] to Denso Wave, which was then validated into French, British, and German patents, all of which are still in force as of November 2011.

The word **QR code** itself is a registered trademark of Denso Wave Incorporated.^[1] In UK, the trademark is registered as E921775, the word "QR Code", with a filing date of 03/09/1998.^[1] The UK version of the trademark is based on the Kabushiki Kaisha Denso (DENSO CORPORATION) trademark, filed as Trademark 000921775, the word "QR Code", on 03/09/1998 and registered on 6/12/1999 with the European Union OHIM (Office for Harmonization in the Internal Market).^[1] The U.S. Trademark for the word "QR Code" is Trademark 2435991 and was filed on 29 September 1998 with an amended registration date of 13 March 2001, assigned to Denso Corporation.^[1]

Variants

Micro QR code is a smaller version of the QR code standard for applications with less ability to handle large scans. There are different forms of Micro QR codes as well. The highest of these can hold 35 numeric characters.^[36]

Model 1 QR code is an older version of the specification. It is visually similar to the widely-seen model 2 codes, but lacks alignment patterns.

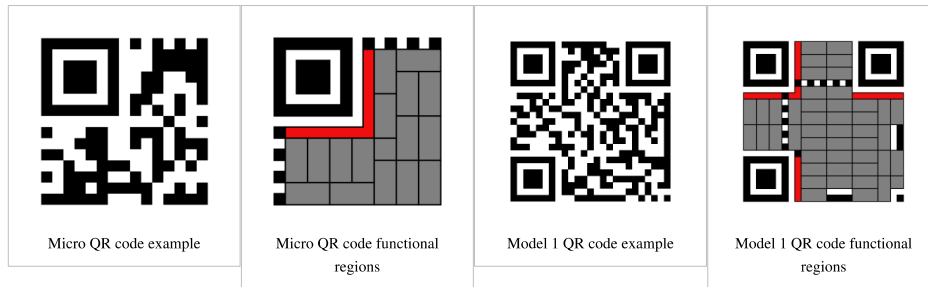

Risks

Malicious QR codes combined with a permissive reader can put a computer's contents and user's privacy at risk. This practice is known as "attagging", a portmanteau of "attack tagging".^[37] They are easily created and can be affixed over legitimate QR codes.^[38] On a smartphone, the reader's permissions may allow use of the camera, full Internet access, read/write contact data, GPS, read browser history, read/write local storage, and global system changes.^{[39][40][41]}

Risks include linking to dangerous web sites with browser exploits, enabling the microphone/camera/GPS, and then streaming those feeds to a remote server, analysis of sensitive data (passwords, files, contacts, transactions),^[42] and sending email/SMS/IM messages or DDOS packets as part of a botnet, corrupting privacy settings, stealing identity,^[43] and even containing malicious logic themselves such as JavaScript^[44] or a virus.^{[45][46]} These actions could occur in the background while the user is only seeing the reader opening a seemingly harmless web page.^[47] In Russia, a malicious QR code caused phones that scanned it to send premium texts at a fee of US\$6 each.^[37]

References

- [3] http://www.iso.org/iso/catalogue/catalogue_ics/catalogue_detail_ics.htm?csnumber=30789
- [4] http://www.iso.org/iso/catalogue/catalogue_tc/catalogue_detail.htm?csnumber=43655
- [10] http://en.wikipedia.org/w/index.php?title=QR_code&action=edit
- [30] — TEC-IT
- [33] <http://worldwide.espacenet.com/textdoc?DB=EPODOC&IDX=US5726435>
- [34] <http://worldwide.espacenet.com/textdoc?DB=EPODOC&IDX=JP2938338>
- [35] http://worldwide.espacenet.com/publicationDetails/biblio?DB=EPODOC&II=0&ND=3&adjacent=true&locale=en_EP&FT=D&date=19950920&CC=EP&NR=0672994A1&KC=A1
- [36] Information technology — Automatic identification and data capture techniques — QR Code 2005 bar code symbology specification, ISO/IEC 18004:2006 cor. 2009, pages 3, 6.
- [37] .
- [46] QR Codes hold up to 2.9 KB whereas the smallest known computer virus is about one-tenth that size

Bibliography

- *BS ISO/IEC 18004:2006. Information technology. Automatic identification and data capture techniques. Bar code symbology. QR Code* (<http://www.worldcat.org/title/information-technology-automatic-identification-and-data-capture-techniques-bar-code-symbology-qr-code-technologies-de-info-oclc/60816353?lang=en>). Geneva: ISO/IEC. 2000. p. 114.
- *BS ISO/IEC 18004:2006. Information technology. Automatic identification and data capture techniques. QR Code 2005 bar code symbology specification* (<http://shop.bsigroup.com/en/ProductDetail/?pid=00000000030201420>). London: BSI. 2007. p. 126. ISBN 978-0-580-67368-9.

External links

- Official website (<http://www.qrcode.com/en/index.html>)
- Reed Solomon Codes for Coders (http://en.wikiversity.org/wiki/Reed_Solomon_codes_for_coders) – an elaborate tutorial on Wikiversity, covering both QR code structure and the Reed Solomon codes used to encode the data.
- J. D. Biersdorfer (2 March 2011). "Q&A: how to Make a Quick Response Code" (<http://www.nytimes.com/2011/03/03/technology/personaltech/03askk.html>). *The New York Times*. Retrieved 11 December 2012. Information on converting a URL into a QR code

Article Sources and Contributors

QR code *Source:* http://en.wikipedia.org/w/index.php?title=QR_code&oldid=554986222 *Contributors:* 100percentrecord, Iexce1, 24fan24, 28bytes, 83d40m, Aandrew22, Aborelli, Absconded Northerner, AbsolutDan, Addshore, Adolushanov, AirWalk009, AircraftWorld, Alan Liefving, Alambach, AlastairIrvine, Alchemy pete, Alex0987, Alfpooh, Alhasgiantongue, Alice160190, AlstairMcMillan, Amicaveritas, Anaxial, Andres, AndrewRH, Antaeus Feldspar, Anthony morgan peters, Apoc2400, Arichmad, Arisa, Arjun01, Atclered, Auntof6, Auric, Autopilot, Avoided, AxelBoldt, Bagworm, Basseg, Bataviaship, Beoffuth, Bert490, BillyBuggy, Black-Velvet, Blehfu, Blobglob, Blumin, Bmusician, Bobmath, Bonadea, Bookchie831, Brakspear, Brandmeister, Brdall, BrianStevenson, Brjodo, Bruce89, Bsadowski1, Bubba73, Buffavento, BurritoBazooka, C.Fred, CHawke, CL, CRobClark, Calvin 1998, CapitallaterBeginning, Carlozbt, Cdezeign, Ceejayoz, Cekli829, Charles Matthews, Charlotte Boersma, Chip123456, Chrisp900, Chrisp900, Closedmouth, Codetesuki, CommonsDelinker, Complicated1, Conny, CoolAmp, Crazycomputers, CredoFromStart, Criskruiff, Crissov, Curb Chain, CustomQRCodes, Cybercobra, D0762, DVTB, Daev, Dancter, Dandy, Daniel Mietenchen, Dankarran, Daschilling, Dave Punktilo, Davidelit, Davidprior, Dbfirs, DePiep, Denisarona, Denso BHT, Dforest, Diego Moya, Dissolve, Djembayz, Di2000, DocWatson42, Dogman15, Donnalibra, Dororai, Download, Eneville, Eddyuzit, Edu82, Elektron, EoGuy, Eprh123, Ergotius, Eric Wester, Erick880, Espejitosdecolores, Ess292, Ewulp, Excirial, Explicit, Eyreland, Fasel, Fhudez, FisherQueen, Fjorden, Flapdragon, Fluffemutter, Fr33dbr33d, Fram, Francisco Paiva Junior, Francyll, FrankMazza, Frankk74, Fe, GPHensley, GVOLTT, Gary King, GaryGolden, Garygoh884, Gelu, Georgfondue, Gimmetoo, Gje238, Glrx, Gmlandsdowne, Goens, Gogo Dodo, GoingBatty, Golbez, Golden herring, GraemeL, Graf von Moltke, Greensburger, GregorB, Gronky, Guillerodiguez, Gütz, Halsteadk, Hankwang, Hanky27, Harddavid, Hardwick, Hawthorn2008, Hel1023, HeseD9, HiDNick, Hippo.69, Hires an editor, Holizz, Hontogaichiban, Hopsta, Horoporo, Hughesjp, Hurmata, HybridBoy, Hydrargyrum, ISBN, Iamjamiq, Igodard, Immanuel Giel, Impressionsplymouth, Inking, Inmonaranja, Ionutmovie, Isharoval, Isnow, Itsallup, IvanLanin, Jackedacker, JamesD Alexander, Jamesnpoe, Jandalhandler, Janswer, Jcevallos, Jchor, Jeallison, Jediknightelectro1997, Jeff G., Jeff Song, Jegan11, JenSullivan, Jeremy A, Jerichbryled, Jerryobject, JesseYUNY, Jgotty, Jhamak, Jheiv, JimBoff, Jimw338, Jiovanmelendez, Joebigwheel, John Behind The Curve, John of Reading, Jordiherandez, Jorge005, Joshis.wiki, Jsgott, Juhachi, Juled, Jun-Dai, Junai.baloch, Justpersona, Kacela, Kakurady, Kallag, Kalone1, Katimawan2005, Kaywa, Keyakins, KelvinMo, Kerrick Staley, Kilopi, KingJ, Kitsunegami, Koo, Koavf, Kocio, Komano90, Kjoze, Kosmtr, Kriplozoik, Krisuy, Kronos, Krugdm, Lambiam, Larryscala, Ldinallo, Legendoftheband, Legoktm, Lele287, Leopicioli, Lester, Lew424, Lightgunner, Lockeevz00, Locoococoloco, Loew Galtz, Lopifalko, Lt2dat, Luccas, Luqmanmaat, Lyla1205, MER-C, Marek69, Marius.radu85, Martin H., Mathsgeek, Mauls, Maurice Carbonaro, Mayalld, Mbarbier, Mbonetri, McGeddon, Memaster3, Merloh, MesserWoland, Metakalyanmita, Mfwitten, Michael Barera, Michael Hardy, MichaelBillington, Mikeay, Miltoncontact, Mindmatrix, MinorProphet, Miserlou, Misterandrade, Mlearning, Mnguru1, Mobilead, Mobiryder, Mono, MontyLov, Mord3n, Mortense, Mrchaotica, Mseguin, Muzikman2787, Myscrmm, N5lin, NFG, NapoliRoma, Nasa-verve, Nathan, Ndenison, Ned Scott, NeilQR, Netalarm, Neurolysis, Nicolas1981, Nifky?, Ninly, Niteowineils, Nloth, Nonaeoroterraqueous, Nopetro, Nurg, O.Kosiowski, OekoIWm, Omoitsjamie, Opjwilliams8, Oliverkeenan, Orangemike, Oren0, OsamaBinLogin, Paberaufai, Paladin656, Panicum, Partizan XXI, PatrikR, Pavel Vozenilek, Pe7er, Pengo, Penguin tki, Pewwer42, Pezzo, Pe.richard, Philip Trueman, Philipjamesbarnes, Pierredecoubertin, Pisonstewing, Pisteuomen, Pwiawika, Pinkyedit, Polluks, Portillo, Portland99, Posidif, Primabaker, Princess Lirin, PumaReest, Puma, Python eggs, Qrc-designer, Qrcodemia, Qrme, Quaeler, RHaworth, RVJ, Rakerman, Randowiki, Repedtor, Remotelysensed, Renart.fox, Renaissance, Rhythmcandy, Rich Farnbrough, Rjwilmsi, Rob392, RobertoVaick, Rotlink, Rrburke, Rsrkanth05, Ryan032, SEKIUCHI, SF007, SSSidorenko, Samsyousewell, Sander123, SchmidJJ, Schnoatbx, Schvorak, Scott Martin, Scribeofargos, Sculptorjones, Seb7, SeymourScamore, Shaddack, ShayaWiki, Shb0, Sheridan, ShizzelFizzle, Siddhan2010, Simerical, Skizzik, Slightsmile, Smwgeek, Socialmaven11, Spike0xFF, Squash, Srice13, Srowen, Staka, SteelMariner, Steffan.stringer, StephenDowling, StevenMcCoy, SudoGhost, SudoGhost (Away), SusanLesch, Svick, Sweeek, SwiflingSpeed, Sxs957, T.O. Rainy Day, T3h, Taminim101, Tcoffin88, Tedder, TerrHikaru, Tesakibeingfree, Textorus, The Anonymouse, The Obento Musubi, The Rambling Man, TheChampionMan1234, Theopolisme, Thewatchdog2012, Thorwald, Thosp, Threc-quarter-cen, Thumperward, TiagoTiago, Tinifakes, TimmmmmCam, Tobias Bergemann, ToddPurgason, TomNor, Tomning357, Tommy2010, TonyBorelli, Toowocoppins, Tototutu, Trivialist, Trounce, Truthamado, Tweisbach, UncleDouggie, Ufofabury, Uriel Peleel, Vasco Bonifacio, Vasco bonifacio, Versageek, Victor Engel, VishalB, Vox Radonis, Vrenator, Wadlck, Walldr, Webapplications, Whatsjshgalt, WhosAsking, Wibbble, Wikidemon, Wikipedantry, Wikipelli, Wikiswatcher1, Will Beback Auto, William Graham, Wla2000, Woodsokitty, Woufu, Writerfound, Wuwvell, WurmWoode, Wwrhr, Xpelient, Xygenlxx, Yerpo, Ynalaka, Yoreciv, Zarcadia, Zeimusu, Zephyris, Zlophi, Zhoulikan, Zinjixmagin, Zubari, 976, 777 anonymous edits

Image Sources, Licenses and Contributors

File:Wikipedia mobile en.svg *Source:* http://en.wikipedia.org/w/index.php?title=File:Wikipedia_mobile_en.svg *License:* Public Domain *Contributors:* brdall, Original uploader was Brdall at en.wikipedia. Later version(s) were uploaded by Serfion, Johndrinkwater, Ke4roh at en.wikipedia.

File:Lista-telefonica.png *Source:* <http://en.wikipedia.org/w/index.php?title=File:Lista-telefonica.png> *License:* Creative Commons Attribution-Sharealike 3.0 *Contributors:* Fernandodosantos

File:QR Code Structure Example 3.svg *Source:* http://en.wikipedia.org/w/index.php?title=File:QR_Code_Structure_Example_3.svg *License:* Creative Commons Attribution-Sharealike 3.0 *Contributors:* User:Bobmath

File:Z80-Tianjin-Beijing.jpg *Source:* <http://en.wikipedia.org/w/index.php?title=File:Z80-Tianjin-Beijing.jpg> *License:* Creative Commons Attribution-Sharealike 3.0 *Contributors:* User:Yaohua2000

File:Qr-1.png *Source:* <http://en.wikipedia.org/w/index.php?title=File:Qr-1.png> *License:* Creative Commons Attribution-Sharealike 3.0 *Contributors:* User:Autopilot

File:Qr-2.png *Source:* <http://en.wikipedia.org/w/index.php?title=File:Qr-2.png> *License:* Creative Commons Attribution-Sharealike 3.0 *Contributors:* User:Autopilot

File:Qr-3.png *Source:* <http://en.wikipedia.org/w/index.php?title=File:Qr-3.png> *License:* Creative Commons Attribution-Sharealike 3.0 *Contributors:* User:Autopilot

File:Qr-4.png *Source:* <http://en.wikipedia.org/w/index.php?title=File:Qr-4.png> *License:* Creative Commons Attribution-Sharealike 3.0 *Contributors:* User:Autopilot

File:QR-code-ver-10.png *Source:* <http://en.wikipedia.org/w/index.php?title=File:QR-code-ver-10.png> *License:* Creative Commons Zero *Contributors:* Bobmath

File:QR-code-ver-40.png *Source:* <http://en.wikipedia.org/w/index.php?title=File:QR-code-ver-40.png> *License:* Creative Commons Attribution-Sharealike 3.0 *Contributors:* User:Bobmath

File:Japan Visa with QR code.jpg *Source:* http://en.wikipedia.org/w/index.php?title=File:Japan_Visa_with_QR_code.jpg *License:* GNU Free Documentation License *Contributors:* Horoporo

File:QR Code Damaged.jpg *Source:* http://en.wikipedia.org/w/index.php?title=File:QR_Code_Damaged.jpg *License:* Creative Commons Zero *Contributors:* Wikipedia_mobile_en.svg: brdall, Original uploader was Brdall at en.wikipedia. Later version(s) were uploaded by Serfion, Johndrinkwater, Ke4roh at en.wikipedia. derivative work: Bobmath (talk)

File:Extreme QR code to Wikipedia mobile page.png *Source:* http://en.wikipedia.org/w/index.php?title=File:Extreme_QR_code_to_Wikipedia_mobile_page.png *License:* Creative Commons Attribution-Sharealike 3.0 *Contributors:* User:Qrc-designer

File:QR Format Information.svg *Source:* http://en.wikipedia.org/w/index.php?title=File:QR_Format_Information.svg *License:* Creative Commons Zero *Contributors:* User:Bobmath

File:QR Character Placement.svg *Source:* http://en.wikipedia.org/w/index.php?title=File:QR_Character_Placement.svg *License:* Creative Commons Zero *Contributors:* User:Bobmath

File:QR Ver3 Codeword Ordering.svg *Source:* http://en.wikipedia.org/w/index.php?title=File:QR_Ver3_Codeword_Ordering.svg *License:* Creative Commons Zero *Contributors:* User:Bobmath

File:QRCode-1-Intro.png *Source:* <http://en.wikipedia.org/w/index.php?title=File:QRCode-1-Intro.png> *License:* Public Domain *Contributors:* Bobmath, Dobie80, Will Pittenger, Wuwvell

File:QRCode-2-Structure.png *Source:* <http://en.wikipedia.org/w/index.php?title=File:QRCode-2-Structure.png> *License:* Public Domain *Contributors:* Bobmath, Will Pittenger, Wuwvell

File:QRCode-3-Layout.Encoding.png *Source:* <http://en.wikipedia.org/w/index.php?title=File:QRCode-3-Layout.Encoding.png> *License:* Public Domain *Contributors:* Bobmath, Will Pittenger, Wuwvell

File:QRCode-4-Levels.Masks.png *Source:* <http://en.wikipedia.org/w/index.php?title=File:QRCode-4-Levels.Masks.png> *License:* Public Domain *Contributors:* Bobmath, Will Pittenger, Wuwvell

File:QRCode-5-Protocols.png *Source:* <http://en.wikipedia.org/w/index.php?title=File:QRCode-5-Protocols.png> *License:* Public Domain *Contributors:* Bobmath, Will Pittenger, Wuwvell

File:Micro QR Example.svg *Source:* http://en.wikipedia.org/w/index.php?title=File:Micro_QR_Example.svg *License:* Creative Commons Zero *Contributors:* User:Bobmath

File:Micro QR Version 3M Layout.svg *Source:* http://en.wikipedia.org/w/index.php?title=File:Micro_QR_Version_3M_Layout.svg *License:* Creative Commons Zero *Contributors:* User:Bobmath

File:QR Code Model 1 Example.svg *Source:* http://en.wikipedia.org/w/index.php?title=File:QR_Code_Model_1_Example.svg *License:* Creative Commons Zero *Contributors:* User:Bobmath

File:Model 1 QR Version 2 Layout.svg *Source:* http://en.wikipedia.org/w/index.php?title=File:Model_1_QR_Version_2_Layout.svg *License:* Creative Commons Zero *Contributors:* User:Bobmath

License

Creative Commons Attribution-Share Alike 3.0 Unported
//creativecommons.org/licenses/by-sa/3.0/

THIS PAGE INTENTIONALLY LEFT BLANK

APPENDIX B—KEY EQUIPMENT SPECIFICATIONS

This appendix provides technical details for the equipment used in this thesis.

A. IPHONE 4S 8 MEGAPIXEL CAMERA



Figure 59. Apple iPhone 4S with 8 Megapixel Digital Camera
(From <http://www.apple.com>).

- 8-megapixel camera, 3264x2448
- Sensor size: 1/3.2 inch (4.54 x 3.42 mm)
- Video recording, HD (1080p) up to 30 frames per second with audio
- High dynamic range
- Full specifications can be found at:
<http://www.apple.com/iphone/iphone-4s/specs.html>

B. CANON POWERSHOT SD880 IS 10 MEGAPIXEL CAMERA



Figure 60. Canon PowerShot SD880 IS Digital Camera (From <http://www.canon.com>).

- Resolution: 10.0 megapixel, 1/2.3-inch (6.2s x 4.6 mm) type CCD
- Total pixels: 10.3 megapixels
- Effective Pixels: 10.0 megapixels
- Lens Focal length: 5.0–20.0mm f/2.8–5.8 (35mm film equivalent: 28–112mm)
- Digital zoom: 4x
- Focusing Range: normal: 1.6ft/50cm-infinity; Macro: 0.8in-1.6ft/2–50cm (W), 1.0–1.6ft/30–50cm (T); Digital Macro: 0.8in-1.6ft/2–50cm (W)
- Maximum Aperture: f/2.8 (W) - f/5.8 (T)
- Shutter Speed: 15–1/1600 sec
- Number of recording pixels: Still image: 3648x2736 (Large), 2816x2112 (Medium 1), 2272x1704 (Medium 2), 1600x1200 (Medium 3/Date Stamp), 640x480 (Small), 3648x2048 (Widescreen); Movie: 640x480 (30 fps), 320x240 (30 fps) available up to 4GB or 60 minutes per clip
- Full specifications can be found at:
http://www.usa.canon.com/cusa/support/cons/umer/digital_cameras/powershot_sd_series/powershot_sd880_is_silver#Specifications

C. CANON EOS 5D MARK II



Figure 61. Canon EOS 5D Mark II DSLR Camera (From <http://www.canon.com>).

- Camera type: Digital, single-lens reflex, AF/AE camera
- Image sensor type: CMOS
- Image sensor effective pixels: Approx 21.10 megapixels
- Image sensor size: Approx 36 x 24 mm
- Image type: JPEG, RAW (14-bit Canon original)
- Recorded pixels: Large: approx. 21.00 megapixels (5616 x 3744); Medium: approx. 11.10 megapixels (4080 x 2720); Small: approx. 5.20 megapixels (2784 x 1856); RAW: approx. 21.00 megapixels (5616 x 3744); sRAW1: approx. 10.00 megapixels (3861 x 2574); sRAW2: approx. 5.20 megapixels (2784 x 1856).
- Shutter speeds: 1/8000 sec to 30 sec, bulb (Total shutter speed range. Available range varies by shooting mode.) X-sync at 1/200 sec
- Full specifications can be found at:
<http://web.canon.jp/imaging/eosd/eos5dm2/specifications.html>

D. JVC GY-HD200 720P VIDEO CAMERA



Figure 62. JVC GY-HD200 720P HD Video Camera (From <http://www.jvc.com>).

- Image pickup device: 1/3" interline-transfer CCDs
- Number of pixels: Total: 1,110,000 pixels
- Electronic Shutter:
- Standard value: 59.94 Hz
- Fixed Values: 7.5–10,000 Hz
- Variable scan: about 60 to 10,000 Hz
- Video recording format: 720/24p, 720/25p, 720/30p, 720/50p, 720/60p, 480/24p, 480/60i
- Video format:
- Video signal recording format: HDV1 format, 8-bit, 19.7MP/s
- Compression: MPEG-2 video
- Sampling frequencies: 720/60p: 74.25/1.001 MHz, 720/50p: 74.25 MHz, 1080/60i: 74.25/1.001 MHz, 1080/50i: 74.25 MHz
- Full specifications can be found at:
http://pro.jvc.com/prof/attributes/features.js p?model_id=MDL101623

E. JVC GY-HM750 1080P VIDEO CAMERA



Figure 63. JVC GY-HM750 1080P HD Video Camera (From <http://www.jvc.com>)

- Image pickup device: 1/3" Progressive IT CCD
- Electronic shutter: 1/6 to 1/10000, EEI
- Video recording file format: QuickTime File Format, MP4 File Format, AVI File Format
- HD video signal (HQ mode): MPEG-2 Long GOP VBR, 35 Mbps (Max) MPEG-2 MP@HL
- HD video signal (SP mode): MPEG-2 Long GOP CBR, 25 Mbps (1440x1080i)/19Mbps (1280x720p) MPEG-2 MP@H14
- HD video format (HQ mode): 1920x1080/59.94i, 29.97p, 23.98p, 1440x1080/59.94i (MOV only), 1280x720/59.94p, 29.97p, 23.98p
- HD video format (SP mode): 1440x1080/59.94i, 1280x720/59.94p, 29.97p, 23.98p
- Full specifications can be found at:
http://pro.jvc.com/prof/attributes/specs.jsp?model_id=MDL102066&feature_id=03

F. DIGITALGLOBE WORLDVIEW-1



Figure 64. WorldView-1 with BHRC 60 Imager (From <http://www.janes.com>).

- Image Device: BHRC 60
- Aperture: 60 cm
- Focal length: 8.8 m
- Resolution: 50 cm GSD at nadir, 29 cm at 25 degrees off nadir, 24.9 megapixels
- Orbit: 496 km sun synchronous
- Full specifications can be found at:
https://janes.ihs.com.libproxy.nps.edu/CustomPages/Janes/DisplayPage.aspx?DocType=Reference&ItemId=+++1384808&Pubabbrev=JSD_#WorldView-1

G. DIGITALGLOBE WORLDVIEW-2



Figure 65. WorldView-2 with WorldView 110 Imager (From <http://www.janes.com>).

- Image Device: Worldview 110
- Aperture: 1.1 m
- Focal length: 13.3 m, f/12
- Resolution: 46 cm GSD at nadir, 52 cm at 20 degrees off nadir, 33.6 megapixels
- Orbit: 770 km sun synchronous
- Full specifications can be found at:
https://janes.ihs.com.libproxy.nps.edu/CustomPages/Janes/DisplayPage.aspx?DocType=Reference&ItemId=+++1384808&Pubabbrev=JSD_#WorldView-1

H. INSTANTEYE STANDARD CAMERA, SHENZHEN 520TVL

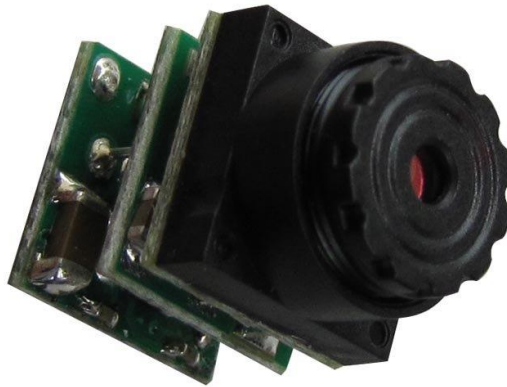

Figure 66. Shenzhen 520TVL Video Camera (From <http://www.alibaba.com>).

- Image device: 1/3 inch color CMOS
- Horizontal resolution: 520TVL
- Minimum illumination: 0.008 Lux
- Effective Pixels: 656 x 492
- Scanning system: 525 lines, 60 frames per second
- SNR: >48dB
- Electronic shutter: 1/60 to 1/100,000, auto
- Lens focal length: 8 mm
- Full specifications can be found at:
<http://www.ecvv.com/product/4046372.html>

I. INSTANTEYE FLIR CAMERA, QUARK 336



Figure 67. Quark 336 LWIR Camera (From <http://www.flir.com>).

- Thermal imager: VOx Microbolometer
- FPA/Digital video display format: 336 x 256
- Analog video display format: 640 x 480
- Pixel pitch: 17 μm
- Spectral band: 7.5–13.5 μm
- Full frame rates: 30/60 Hz
- Exportable frame rates: 7.5 Hz
- Lens focal length: 13 mm
- Full specifications can be found at:
<http://www.flir.com/cvs/cores/view/?id=51266>

J. CANON DC420



Figure 68. Canon DC420 Digital Camcorder (From <http://www.canon.com>).

- Image sensor: 1/6 inch CCD
- Resolution: 1.07 Megapixels
- Effective Pixels: 0.55 Megapixels
- Lens focal length: 2.6–96.2 mm
- Full specifications can be found at:
http://www.usa.canon.com/cusa/support/cons umer/camcorders/dvd_camcorders/dc420#Specifications

K. GOPRO HERO3 BLACK



Figure 69. GoPro Hero3 Black 4K Video Camera (From <http://www.gopro.com>).

- 4K frame rate: 15 fps
- 4K screen resolution: 3840 x 2160
- 2.7K frame rate: 30 fps
- 2.7K screen resolution: 2704 x 1524
- Lens focal length: 12 mm
- Full specifications can be found at: <http://gopro.com/cameras/hd-hero3-black-edition#specs>

L. ASTRO DESIGN 4K CAMERA SYSTEM, AH-4413



Figure 70. Astro AH-4413 4K Camera Head (From <http://www.astrodesign.co.jp>).

- Resolution: 4K, 8.9 Megapixels, 3840 x 2160
- Sensor: Single plate CMOS
- Frame Rate: 60p
- Dynamic Range: F8
- Shutter Speeds: 60 (off), 1/100, 1/120, 1/240, 1/480, 1/960, 1/1920 seconds
- Full specifications can be found at:
http://www.astrodesign.co.jp/english/product/ah-4413_ap-4414_am-4412

THIS PAGE INTENTIONALLY LEFT BLANK

APPENDIX C—EXPERIMENT SCHEDULE OF EVENTS

The following experiments were initially planned for this research. Due to time and resource constraints, only experiments B, C, D, and I were completed. The remainder of experiments should be completed as future work.

A. BASELINE DISTANCE SIMULATION

Date: 26 – 30 November 2012

Objective: Determine the most distant readable QR code for each image capturing device through lab simulation.

B. BASELINE DISTANCE VALIDATION EXPERIMENT

Date: 26 – 30 November 2012

Objective: Determine the most distant readable QR code for each image capturing device through field experimentation.

C. BASELINE ANGULAR SIMULATION

Date: 3 – 7 December 2012

Objective: Determine the widest off-perpendicular angle at which a QR code can be read through lab simulation.

D. BASELINE ANGULAR VALIDATION EXPERIMENT

Date: 3 – 7 December 2012

Objective: Determine the widest off-perpendicular angle at which a QR code can be read through field experimentation.

E. PROBABILITY OF DETECTION SIMULATION

Date: 9 – 15 December 2012

Objectives: Determine optimal positioning and initial probabilities for QR code detection through lab simulation.

F. PROBABILITY OF DETECTION VALIDATION EXPERIMENT

Date: 9 – 15 December 2012

Objectives: Determine optimal positioning and initial probabilities for QR code detection through field experimentation.

G. AIRCRAFT/UAV QR CODE DETECTION

Date: 7 – 11 January 2013

Objective: Validate baseline simulation data and demonstrate ability to read a QR code from an aircraft.

H. SATELLITE IMAGERY QR PIXEL AND QR CODE DETECTION

Date: 13 – 19 January 2013

Objective: Validate baseline simulation data and demonstrate ability to read a QR code from an orbiting spacecraft.

I. USV TWO-WAY QR CODE DETECTION

Date: 20 – 26 January 2013

Objective: Validate baseline simulation data and demonstrate ability to read a water vessel mounted QR code in a realistic environment.

APPENDIX D—SIMULATION AND EXPERIMENT DATA

This data represents both simulation and field experiment results. The tables are interpreted with the following legend:

Legend
Decoded by direct evaluation with QR Sight
Decoded only by secondary evaluation despite further range points successfully decoded by direct evaluation
Decoded by secondary evaluation with Google Goggles or QRReader
Not Decoded by any means

Table 13. Simulation and Field Experiment Results Legend

Associated with each imaging device is:

- The focal length of the optics used during the experiment measured in mm.
- The resolution of each image sensor measured in megapixels.
- The CCF allowing the results to be related to both the focal length and the resolution of the equipment used for each experiment. The CCF is the product of the focal length and the resolution.

Digital Display					
	Still Camera Images			Video Camera Images	
Sensor	iPhone 4S	Canon SD880	Canon 5D MkII	JVC GY-HD200	JVC GY-HD750
Focal Length (mm)	4.28	5	50	5.5	5.5
Megapixels	8	10	21.1	0.9	2.1
CCF	34.2	50.0	1055.0	5.0	11.6
Image Size (% of 17 in X 17 in)	66	66	66	66	66

	35	35	35	35	35
	34	34	34	34	34
	33	33	33	33	33

	28	28	28	28	28
	27	27	27	27	27
	26	26	26	26	26
	25	25	25	25	25

	21	21	21	21	21
	20	20	20	20	20
	19	19	19	19	19
	18	18	18	18	18
	17	17	17	17	17
	16	16	16	16	16
	15	15	15	15	15
	14	14	14	14	14
	13	13	13	13	13

7	7	7	7	7	
6	6	6	6	6	
5	5	5	5	5	

Table 14. Digital Display Simulation Data

Printed Display					
	Still Camera Images			Video Camera Images	
Sensor	iPhone 4S	Canon SD880	Canon 5D MkII	JVC GY-HD200	JVC GY-HD750
Focal Length (mm)	4.28	5	24	5.5	5.5
Megapixels	8	10	21.1	0.9	2.1
CCF	34.24	50	506.4	4.95	11.55
Image Size (% of 13.25 in X 13.25 in)	14	14	14	14	14
	13	13	13	13	13
	12	12	12	12	12
	11	11	11	11	11
	10	10	10	10	10
	9	9	9	9	9
	8	8	8	8	8
	7	7	7	7	7
	6	6	6	6	6
	5	5	5	5	5

Table 15. Printed Display Simulation Data

Range Analysis						
Still Camera Images						
Sensor	iPhone 4S	Canon SD880IS		Canon 5D MkII		
Focal Length (mm)	4.28	5	20	24	85	200
Megapixels	8	10	10	21.1	21.1	21.1
CCF	34.2	50.0	200.0	506.4	1793.5	4220.0
Range (yds)	19	85	85	3	85	84
	27	93	93	15	93	94
	33	100	100	24	100	105
	41	108	108	34	108	118
	50	114	114	46	114	130
	59	127	127	59	127	143
	67	136	136	71	136	157
	75	143	143	81	143	176
	81	201	201	84	148	189
	89			85	158	199
	95			94	167	207
	100			96	175	222
				105	185	235
					196	249
					201	263
					207	275
						289
						303
						311
						321
						335
						347
						356
						368
						379
					390	
					402	
					413	
					428	
					442	
					457	
					470	
					482	
					495	
					505	

Table 16. Still Image Camera Field Experiment Data

Video Camera Range Analysis					
Sensor	Canon DC420	JVC HD200	JVC HD750	GoPro 2.7K	GoPro 4K
Focal Length (mm)	96.2	88	88	12	12
Megapixels	0.55	0.9	2.1	4.1	8.3
CCF	52.9	79.2	184.8	49.2	99.6
Range (yds) Note: Range values are not correlated between columns	43	84	42	6	3

	84	130	207	22	7
	97	143	217	26	8
	109	157	227	30	9
	120	...	237	35	14
	134	334	...	40	19
	143	345	257	45	24
	156	355	258		29
	165	367	266		34
	178	377	269		40
	189	387	275		45
	200	397	279		51
	202	408	285		
	213	418	289		
	227	428	294		
	241	441	298		
	255	453	303		
	270	464	...		
	284	476	402		
	302	486	413		
		497	428		
		503	442		
	505	457			
		470			
		482			
		495			
		505			

Table 17. Video Camera Field Experiment Data.

THIS PAGE INTENTIONALLY LEFT BLANK

LIST OF REFERENCES

- Bushnell. (n.d.). Laser range-finder elite 1600 ARC [Image]. Retrieved from <http://www.bushnell.com/all-products/laser-rangefinders/more/elite-1600-arc>
- Digital semaphore: QR codes for tactical signaling*. (2012). Retrieved from NPS Savage Defense website: <https://savagedefense.nps.navy.mil/qr/index.php/Report>
- EM2 MMOWGLI: Massive Multiplayer Online Wargame Leveraging the Internet*. (2013). Retrieved from Naval Postgraduate School website: <https://mmowgli.nps.edu/em2>
- Fox, M. (2011, June 15). Alan Haberman, who ushered in the bar code, dies at 81. *New York Times*. Retrieved from <http://www.nytimes.com>
- Frehlich, R. (1992). Laser scintillation measurements of the temperature spectrum in the atmospheric surface layer. *Journal of Atmospheric Science*, 49, 1494–1509. doi: [http://dx.doi.org/10.1175/1520-0469\(1992\)049<1494:LSMOTT>2.0.CO;2](http://dx.doi.org/10.1175/1520-0469(1992)049<1494:LSMOTT>2.0.CO;2)
- Hamming, R. W. (1950). Error detecting and error correcting codes. *The Bell System Technical Journal*, 29(2), 147–160.
- Holst, G.C. (1998). *CCD arrays cameras and displays* (2nd ed.). Winter Park, FL: JCD Publishing.
- International Organization for Standards (ISO). (2006, September 01). *Information technology—automatic identification and data capture techniques—QR code 2005 bar code symbology specification* (ISO/IEC 18004:2006(E)). Retrieved from ISO website: http://www.iso.org/iso/iso_catalogue/catalogue_tc/catalogue_detail.htm?csnumber=43655
- Kieseberg, P., Leithner, M., Mulazzani, M., Munroe, L., Schrittwieser, S., Sinha, M., & Weippl, E. (2010). QR code security. *Eighth International Conference on Advances in Mobile Computing and Multimedia*. 430–435. doi: 10.1145/1971519.1971593.
- Kline, J., & Englehorn, L. (2011). *Consortium for Robotics and Unmanned Systems Education and Research (CRUSER): Warfare innovation workshop (WIW) 2011 after action report*. Naval Postgraduate School, Monterey, CA. Retrieved from: <http://libguides.nps.edu/loader.php?type=d&id=767993>
- Lewis, J.M. (1928). *A digest of naval communications*. Annapolis, MD: The United States Naval Institute.
- Liao, Y., Lin, C. Sheih, J., & Zhang, J. (2011). Enhancing the recognition rate of two-dimensional barcodes, images, and applications. *Fourth International Congress*

- on Image and Signal Processing (CISP), Volume 3.* 1567–1571. doi: 10.1109/CISP.2011.6100506.
- QR barcode generator.* (n.d.) Retrieved from RACO Industries website: <http://www.racoindustries.com/barcodegenerator>
- Richter, S. P. (2013). *Digital Semaphore: Tactical Implications of QR Code Optical Signaling for Fleet Communications* (Master's thesis, Naval Postgraduate School, Monterey, CA).
- Sokol, C. R. (2013). *A study on using quick response codes in airport surface operations to reduce accidents and incidents while taxiing* (Unpublished master's thesis). Embry-Riddle Aeronautical University, Daytona Beach, FL.
- Starling, H. D. (2008). *Naval telecommunications procedures (NTP 4(E))*. Retrieved from https://wwwa.nko.navy.mil/gear/library/download?document_id=v4doc112900088.
- Sutheebanjard, P., & Premchaiswadi, W. (2010). QR-code generator. *Eighth International Conference on ICT and Knowledge Engineering*. 89–92. doi: 10.1109/ICTKE.2010.5692920.
- Wikipedia: General Disclaimer. (n.d.). In *Wikipedia*. Retrieved May 15, 2013, from http://en.wikipedia.org/wiki/Wikipedia:General_disclaimer
- Wilson, T. (1986). *Flags at sea*. Greenwich: National Maritime Museum.

INITIAL DISTRIBUTION LIST

1. Defense Technical Information Center
Ft. Belvoir, Virginia
2. Dudley Knox Library
Naval Postgraduate School
Monterey, California