

REPORT DOCUMENTATION PAGE			<i>Form Approved</i> OMB No. 0704-0188	
Public reporting burden for this collection of information is estimated to average 1 hour per response, including the time for reviewing instructions, searching existing data sources, gathering and maintaining the data needed, and completing and reviewing this collection of information. Send comments regarding this burden estimate or any other aspect of this collection of information, including suggestions for reducing this burden to Department of Defense, Washington Headquarters Services, Directorate for Information Operations and Reports (0704-0188), 1215 Jefferson Davis Highway, Suite 1204, Arlington, VA 22202-4302. Respondents should be aware that notwithstanding any other provision of law, no person shall be subject to any penalty for failing to comply with a collection of information if it does not display a currently valid OMB control number. PLEASE DO NOT RETURN YOUR FORM TO THE ABOVE ADDRESS.				
1. REPORT DATE (DD-MM-YYYY) 16-07-2008		2. REPORT TYPE Final Performance Report		3. DATES COVERED (From - To) From 16-07-2008 To 23-02-2012
4. TITLE AND SUBTITLE (DEPSCOR FY08) SELF-ENCODED SPREAD SPECTRUM MODULATION FOR ROBUST ANTI-JAMMING COMMUNICATION			5a. CONTRACT NUMBER	
			5b. GRANT NUMBER FA9550-08-1-0393	
			5c. PROGRAM ELEMENT NUMBER	
6. AUTHOR(S) Dr. Lim Nguyen			5d. PROJECT NUMBER	
			5e. TASK NUMBER	
			5f. WORK UNIT NUMBER	
7. PERFORMING ORGANIZATION NAME(S) AND ADDRESS(ES) UNIV OF NEBRASKA - LINCOLN Computer And Electronics Engineering 6100 West Doodge Street Omaha, NE 68182-0000			8. PERFORMING ORGANIZATION REPORT NUMBER	
9. SPONSORING / MONITORING AGENCY NAME(S) AND ADDRESS(ES) AFOSR / RSE 875 North Randolph Street, Suit 325 Room 3112 Arlington, Virginia 22203-1768			10. SPONSOR/MONITOR'S ACRONYM(S) AFOSR/RSE	
			11. SPONSOR/MONITOR'S REPORT NUMBER(S) AFRL-OSR-VA-TR-2012-0505	
12. DISTRIBUTION / AVAILABILITY STATEMENT 1) DISTRIBUTION STATEMENT A: Approved for public release; distribution is unlimited				
13. SUPPLEMENTARY NOTES This PI was lost; the final is a compilation of his previous reports				
14. ABSTRACT This research investigates a novel self encoded spread spectrum (SESS) technique to provide signal protection and maintain reliable communication in the presence of interference and hostile jamming that exist in the modern battlefield environment. Military communications must be jam-resistant, or anti-jamming (AJ), and are subjected to the fading and multipath nature of wireless channels. Pseudo-random noise (PN) spread spectrum technique was developed in the mid-1950 for AJ capability and have found applications in tactical communication systems ranging from point-to-point communications to satellite links and multiple access networks. This technique has been the technology for advance mobile telephony and Global Positioning Systems (GPS). The performance of a PN spread spectrum system, however, can be severely degraded by intelligent signal jammers. The goal of our proposed research is to develop and demonstrate innovative SESS modulation techniques that significantly enhance AJ capability. The proposed techniques eliminate the PN codes employed in conventional spread spectrum systems, thereby can potentially provide robust AJ performance due to the stochastic nature of the unique spectrum spreading and de-spreading processes. Initial works have shown that SESS modulation is extremely robust in fading channels without the explicit need for diversity and error control coding. Preliminary results have also demonstrated that the SESS waveforms also yield significant performance improvement in multiple inputs-multiple outputs systems. The principal significance of this project will be its breakthroughs in AJ technology that advance AJ communication capability in a tactical environment. Additional major outcome of the research includes information theoretic spread spectrum communications that opens new research frontiers and potential applications in GPS and satellite communications.				
15. SUBJECT TERMS Novel Self Encoded Spread Spectrum (SESS), SESS technique, Jam-Resistant or Anti-Jamming (AJ), Pseudo-Random Noise (PN)				
16. SECURITY CLASSIFICATION OF:			17. LIMITATION OF ABSTRACT UU	18. NUMBER OF PAGES
a. REPORT U	b. ABSTRACT U	c. THIS PAGE U		
				19b. TELEPHONE NUMBER (include area code) 703.696.6564

**Defense Experimental Program to Stimulate
Competitive Research (DEPSCoR)**

**Self-Encoded Spread Spectrum Modulation
for Robust Anti-Jamming Communication**

Annual Report

30 June, 2009

Submitted to U.S. Air Force Office of Scientific Research

Award No. FA9550-08-1-0393

Program Manager: Dr. Jon A. Sjogren, AFOSR/NE

**Principle Investigator: Lim Nguyen
Co-Principle Investigator: Won Mee Jang**

**Department of Computer & Electronics Engineering
The Peter Kiewit Institute of Information Sciences, Technology, and Engineering
University of Nebraska-Lincoln
Email: lnguyen1@unl.edu**

Table of Contents

Abstract	3
1. Background	4
2. Research Issues	5
3. Scientific Progress and Accomplishments	6
3.1 Coded-Sequence Self-Encoded Spread Spectrum Communications	6
3.2 Synchronization of Self-Encoded Spread Spectrum System	9
3.3 Self Encoded Spread Spectrum Communications using FH-MFSK	11
3.4 Self Encoded Spread Spectrum Multiple-Input Multiple-Output System	13
3.5 Multi-Code Self Encoded Spread Spectrum Multiple-Input Multiple-Output System	16
3.6 Cooperative SESS in Fading Channels	18
3.7 Self-Encoded Multiple Access and Convolutional Codes	18
4. Conclusions	19
Appendix	20

Abstract

This research investigates a novel self encoded spread spectrum (SESS) technique to provide signal protection and maintain reliable communication in the presence of interference and hostile jamming that exist in the modern battlefield environment. Military communications must be jam-resistant, or anti-jamming (AJ), and are subjected to the fading and multipath nature of wireless channels. Pseudo-random noise (PN) spread spectrum technique was developed in the mid-1950 for AJ capability and have found applications in tactical communication systems ranging from point-to-point communications to satellite links and multiple access networks. This technique has been the technology for advance mobile telephony and Global Positioning Systems (GPS). The performance of a PN spread spectrum system, however, can be severely degraded by intelligent signal jammers.

The goal of our proposed research is to develop and demonstrate innovative SESS modulation techniques that significantly enhance AJ capability. The proposed techniques eliminate the PN codes employed in conventional spread spectrum systems, thereby can potentially provide robust AJ performance due to the stochastic nature of the unique spectrum spreading and de-spreading processes. Initial works have shown that SESS modulation is extremely robust in fading channels without the explicit need for diversity and error control coding. Preliminary results have also demonstrated that the SESS waveforms also yield significant performance improvement in multiple inputs-multiple outputs systems.

The principal significance of this project will be its breakthroughs in AJ technology that advance AJ communication capability in a tactical environment. Additional major outcome of the research includes information theoretic spread spectrum communications that opens new research frontiers and potential applications in GPS and satellite communications.

1. Background

The research team consists of Professors Lim Nguyen and Won Mee Jang who are faculty members from the Department of Computer and Electronics Engineering with the Peter Kiewit Institute of Information Science, Technology, and Engineering at the University of Nebraska-Lincoln. Together, the principal investigators for this project have extensive industrial and academic experience in both theoretical and experimental aspects of RF and optical communications, multi-user CDMA systems, transmitter precoding and code modulation, as well as multi-path channels.

The goal of the project is to develop and demonstrate self-encoded spread spectrum (SESS) modulation techniques that can significantly improve AJ capability. The approach is based on the unconventional SESS techniques that we have invented at the University of Nebraska for the modulation and detection of spread spectrum signals. Self encoding employs the random digital information itself to generate the spreading sequences, thereby eliminating the traditional pseudo-noise (PN) code generators altogether and can potentially provide robust AJ performance due to the stochastic nature of the unique spectrum spreading and de-spreading process.

The specific objectives of this project is to determine the performance of DS- and FH-SESS modulation in the presence of worst-case jamming, develop innovative SESS schemes that further exploit time and spatial diversities for enhanced AJ performance, and to construct a proof of concept prototype to demonstrate robust AJ performance.

The fundamental results from this research will inspire new system architectures and stimulate new advance in spread spectrum communications. The potential applications of the knowledge and innovations developed from this project include terrestrial wireless systems, GPS and satellite communications. One of the critical GPS applications in the United States Air Force is the timing accuracy required for the operation of precision guided-munitions and weapons. The GPS receiver signal is low power and therefore susceptible to jamming and interference. The nano-second level timing accuracy can be corrupted by the jamming signals. Similarly the effect of scintillations can degrade GPS timing accuracy. The proposed SESS can provide improved AJ capability and will secure and enhance the timing accuracy achievable with current GPS receiver technology.

This report describes the specific accomplishments for the past year from 1 July, 2008 through 30 June, 2009. During this period the project team has written 5 journal papers that have been published or accepted for publication, presented 1 conference paper and completed 5 manuscripts that have been submitted to peer-reviewed conferences. Also during this period, Professor Lim Nguyen received the 3-year Hollings Family Distinguished Engineering Educator appointment in the College of Engineering (2009 – 2012) at the University of Nebraska-Lincoln. Professor Nguyen was also selected to be a Program Evaluator for Electrical and Computer Engineering programs by the Accreditation Board for Engineering and Technology (ABET). One graduate student received his Ph.D. degree in August 2008, and one graduate student received her M.S. degree in December 2008.

A summary of the primary research advances made during the past year is provided in the following sections. A more detailed description of the results can be obtained from the referenced papers and submitted manuscripts in the Appendix.

2. Research Issues

In considering the application of SESS as a robust communication technique in a jamming and fading wireless environment, a fundamental research issue is to determine the optimum performance of SESS under pulsed noise, multi-tone and partial band jamming. As in the fading environment, we wish to develop receiver that exploits the inherent SESS time diversity to achieve robust performance in the presence of jamming. The jamming performance of SESS is quantified by the available processing gain and anti-jamming margin from the optimum and sub-optimum SESS detectors.

The project activities focus on three areas: analytical modeling and theoretical analysis, simulation study, and experimental prototype development. Specifically, the project goal and objectives will be achieved through the execution of the following tasks.

- Task 1: Determine BER and AJ performance of the feedback and iterative detectors in DS-SESS under pulsed-noise and multi-tone jamming
- Task 2: Develop a scheme for FH-SESS and determine its performance under multi-tone and partial band jamming
- Task 3: Analyze the performance of DS- and FH-SESS under the combined jamming and channel fading
- Task 4: Develop a theoretical framework for MIMO-SESS (multiple-input multiple-output) and determine the performance of under jamming and channel fading
- Task 5: Investigate SESS structures and waveforms to achieve additional gain beyond 3dB and enhance the inherent time diversity
- Task 6: Develop an experimental prototype system to verify the analytical and simulation results, and to demonstrate the theoretical principles
- Task 7: Investigate multi-carrier self-encoded multiple access (MC-SEMA) and GPS applications
- Task 8: Investigate cooperative SESS in fading channels to improve the system performance significantly over conventional cooperative systems.
- Task 9: Investigate SEMA and convolutional codes to provide fewer cross-correlation among users and thereby to reduce multiple access interference.

During the first annual performance period that ends 30 June, 2009, the project team has commenced broad research activities across these tasks. Some research efforts, notably on tasks 2, 4, 5, 8 and 9 have produced results that are further along than others. Their scientific progress and accomplishments are described in the next section.

3. Scientific Progress and Accomplishments

3.1 Coded-Sequence Self-Encoded Spread Spectrum Communications

SUMMARY OF ACCOMPLISHMENTS (PI Lim Nguyen, Student Poomathi Duraisamy)

We have invented the CS-SESS scheme as shown by the block diagram in Figure 1 and analyzed its BER performance in AWGN channel. Our results, plotted in Figure 2, showed that there is essentially no performance degradation in CS-SESS with feedback detection under nominal conditions when $N > 64$ and $\text{SNR} > 4\text{dB}$. Furthermore, since the modulation memory depth of CS-SESS is $2N$ compared to N in SESS, additional performance gain beyond the 3dB in SESS is possible with CS-SESS without a bandwidth expansion.

We have also developed the iterative detector that exploits the modulation memory to achieve the additional gain. Since the computation complexity of the iterative detector grows linearly with the spreading length N , it has a practical advantage over the optimum MLSE detector based on the Viterbi algorithm that has an exponential complexity and therefore is impractical given the long constraint length $(2N+1)$ of CE-SESS modulation. Our results demonstrated that iterative detection can significantly improve the system performance at $\text{SNR} > 4\text{dB}$ even with a modest spreading length of only 16. Figure 3 shows that the iterative detector for CS-SESS can achieve the maximum possible gain of 4.7dB at 10^{-5} BER for $N > 32$.

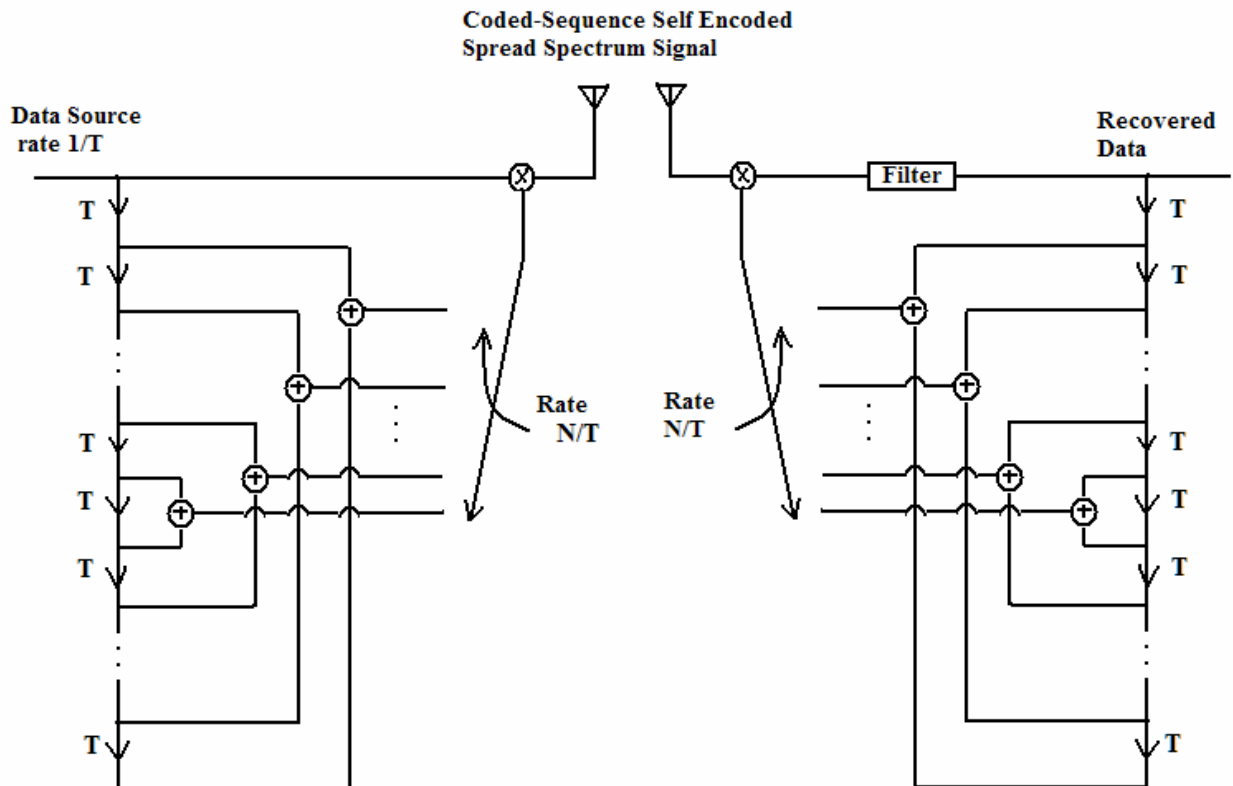

Figure 1. Block diagram of CS-SESS.

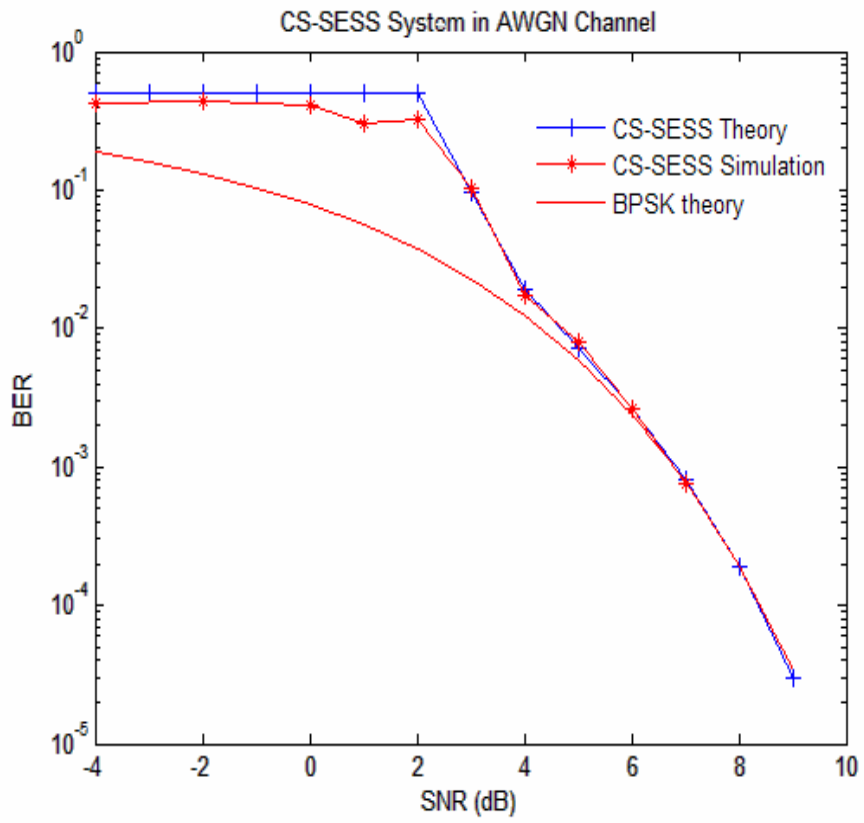

Figure 2. BER performance of feedback detector.

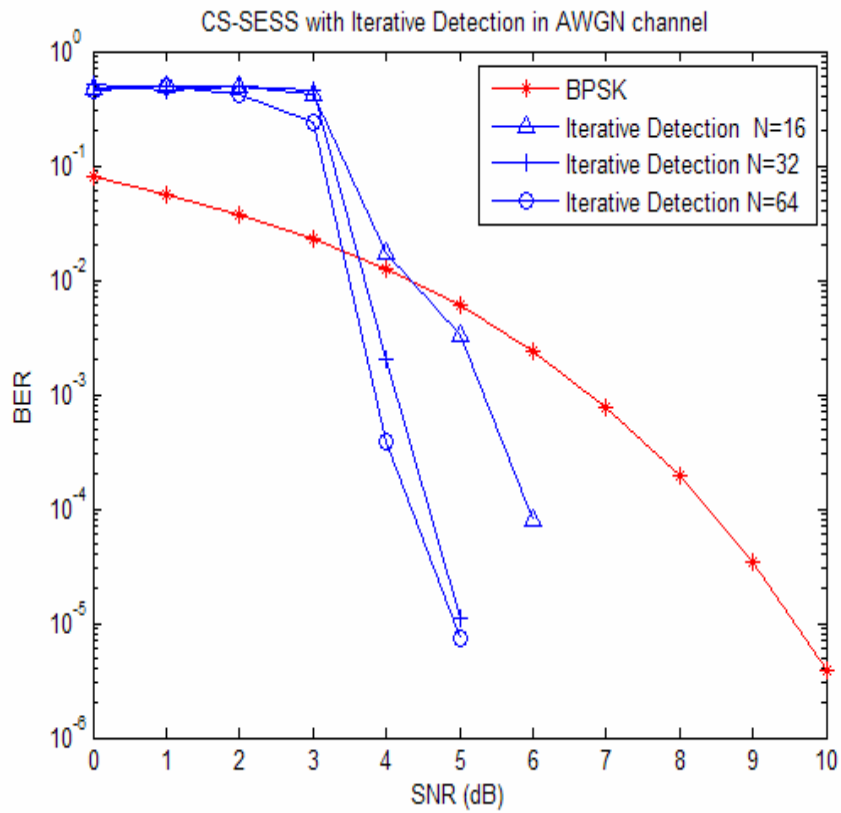

Figure 3. BER performance with iterative detection.

We have also derived the analytical performance of the feedback detector in Rayleigh fading channels. Figure 4 shows that the theoretical calculations agree very well with the simulation results. We also verified that the iterative detector can exploit the inherent time diversity in CS-SESS modulation signal. The performance gain is about 27dB to 29dB at 10^{-4} BER depending on whether chip interleaving is employed. The results in Figure 5 demonstrated that CS-SESS is extremely robust in fading environments, achieving a BER performance of 10^{-4} at 6dB SNR.

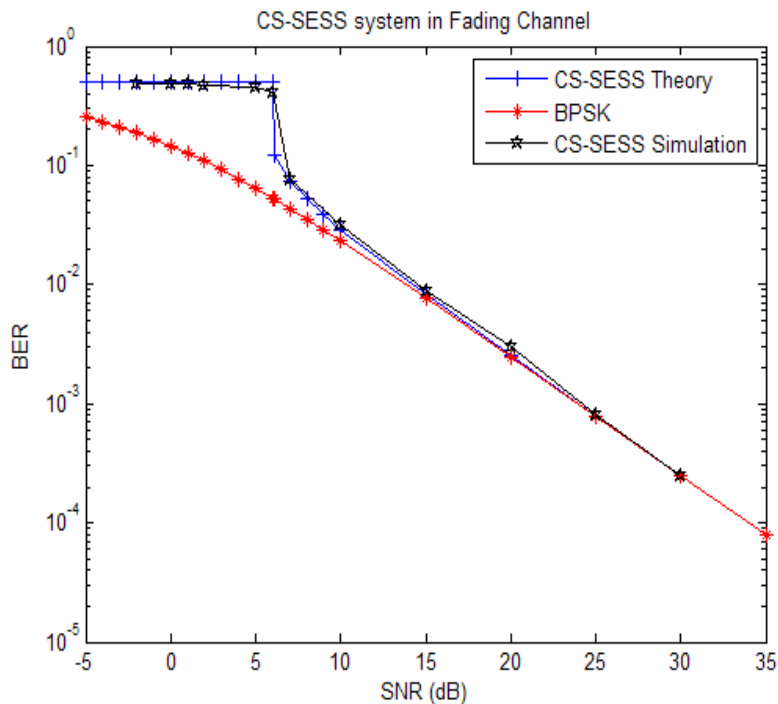

Figure 4. Feedback detector performance under flat fading.

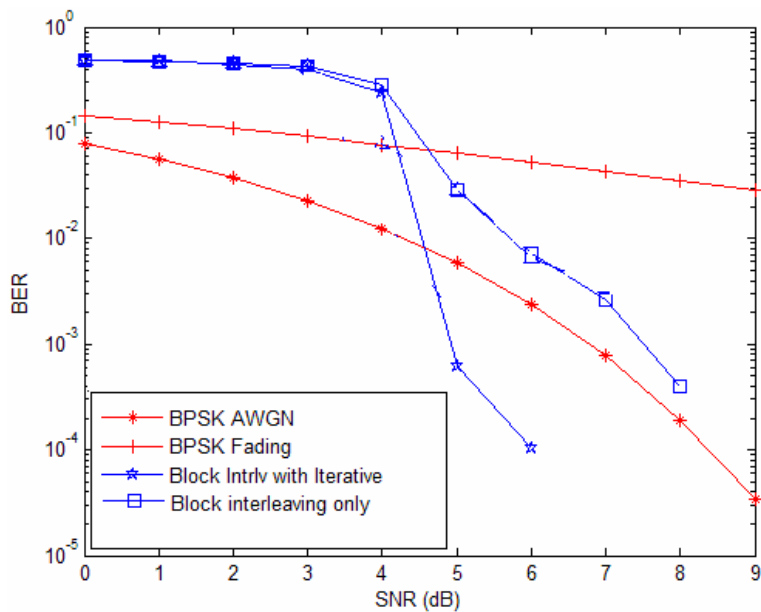

Figure 5. Performance of iterative detector under flat fading.

3.2 Synchronization of Self-Encoded Spread Spectrum System

SUMMARY OF ACCOMPLISHMENTS (PI Lim Nguyen, Student Kun Hua)

We have analyzed SESS synchronization by means of a genetic model and Markov chain. This approach employs genetic search algorithm in the sequence generation and revision. Initial acquisition is achieved when the transmitter spreading sequence has been reproduced at the receiver to within an acceptable number of initial chip errors m . In tracking, the reproduced sequence with initial chip errors is then transited into the error-free state. We have obtained the analytical and simulation results to demonstrate the veracity of genetic model and Markov chain analysis for SESS synchronization. We have shown that for a given SNR, there is a minimum synchronization time that can be obtained by selecting an optimum acquisition threshold. The SESS synchronization performance was demonstrated with simulation results for an example spreading length of 64.

Figure 6 compares the theoretical acquisition time to the simulation results of the genetic algorithm with different SNR. As would be expected, the results show that the acquisition time decreases as the acquisition chip error m increases. Also, as the SNR increases from 4dB to 8dB, the simulation results approach the theoretical calculation which represents a lower bound. Figure 7 plots the example tracking time based on Markov chain analysis and simulation. As also expected, the tracking time increases significantly with m .

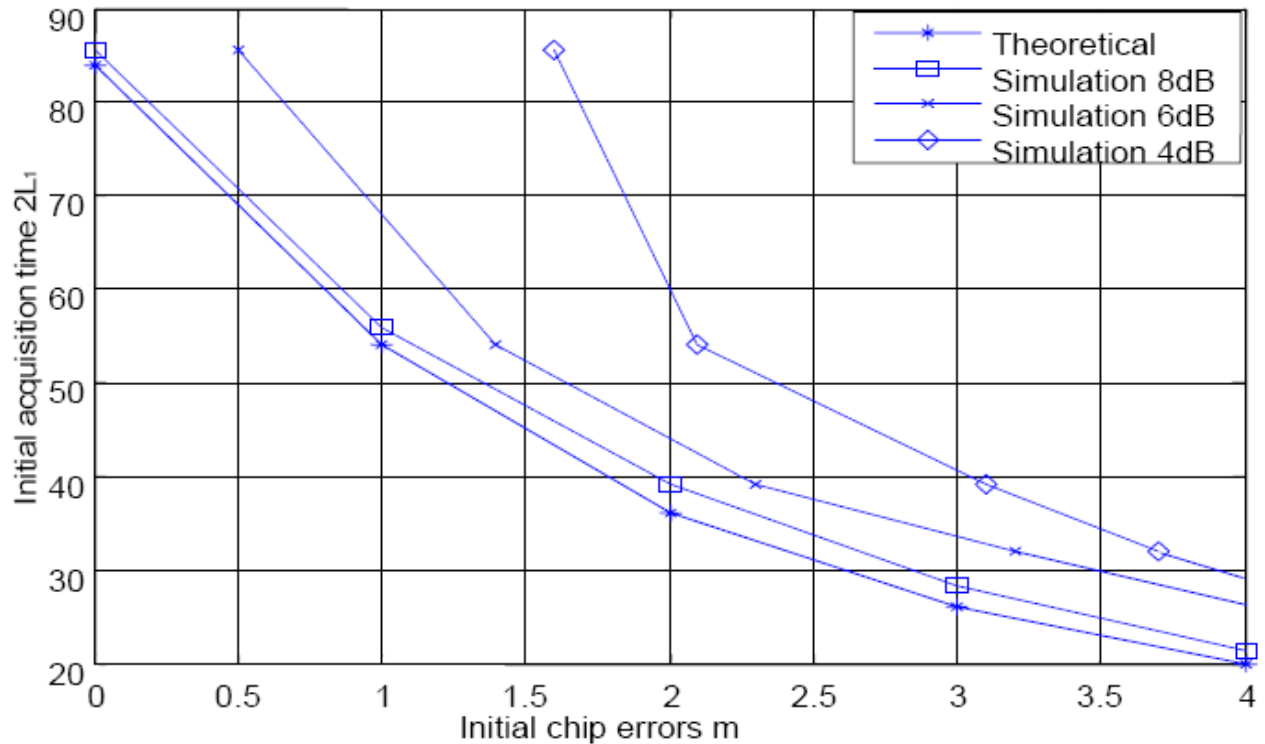

Figure 6. Acquisition time of SESS with Genetic Algorithm.

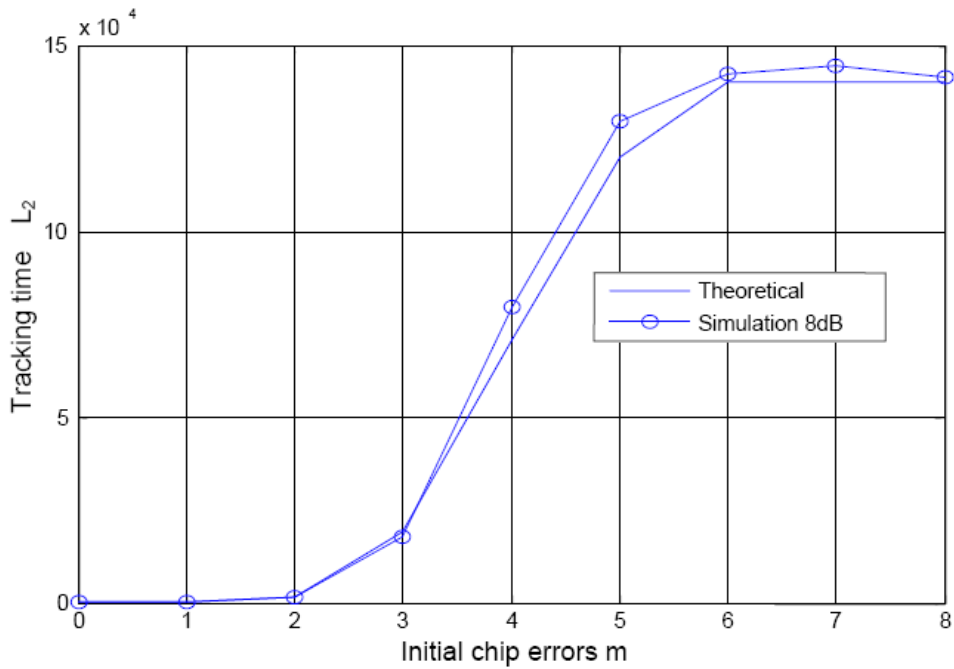

Figure 7. Tracking time of SESS with Markov analysis.

Figure 8 plots the synchronization performance with the SNR varying from 3dB to 8dB. The plots show that the overall synchronization time decreases as SNR increases. The results show that the synchronization performance is clearly dominated by the initial acquisition phase when the normalized correlation threshold, $1 - 2m/N$, is high (smaller m), while it is dominated by the tracking phase when the threshold is low (larger m). Therefore, a minimum synchronization time can be achieved by setting an appropriate acquisition threshold. As an example, Figure 8 shows that an optimum threshold value of 0.65 would yield a mean synchronization time of 170 bits at 8dB SNR.

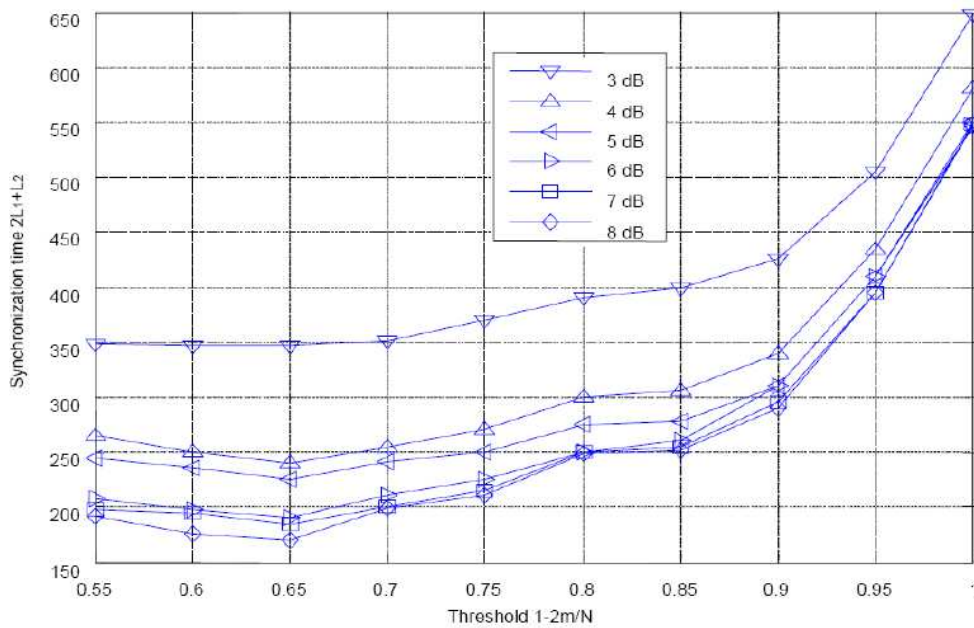

Figure 8. Synchronization time of SESS.

3.3 Self Encoded Spread Spectrum Communications using FH M-FSK

SUMMARY OF ACCOMPLISHMENTS (PI Lim Nguyen, Student Steve Fahey)

The SESS FH-MFSK technique shows promise as a means to reliably communicate using a spreading code derived from the randomness of the source itself. FH method eliminates the need for contiguous bandwidth and can offer greater effective spreading bandwidth, complicating the task of an intended jammer. We have obtained preliminary results of self-encoded frequency hopping scheme based on fast hopping and majority-vote detector that allows a TX and RX pair to remain reasonably synchronized as the source alphabet size, number of FH bands, and number of hops/symbol vary.

Figure 9 plots the example BER performance of an 8-ary FSK with 5 hops per symbol. The results show a performance difference of approximately 2.5-3.0 dB between the majority vote method and the theoretical lower bound performance (with no spreading). This difference in performance might be improved further if the majority vote scheme employed an M-FSK demodulator that integrates the received energy over all hops in a symbol before making a hard decision rather than making hard decisions on a hop-by-hop basis.

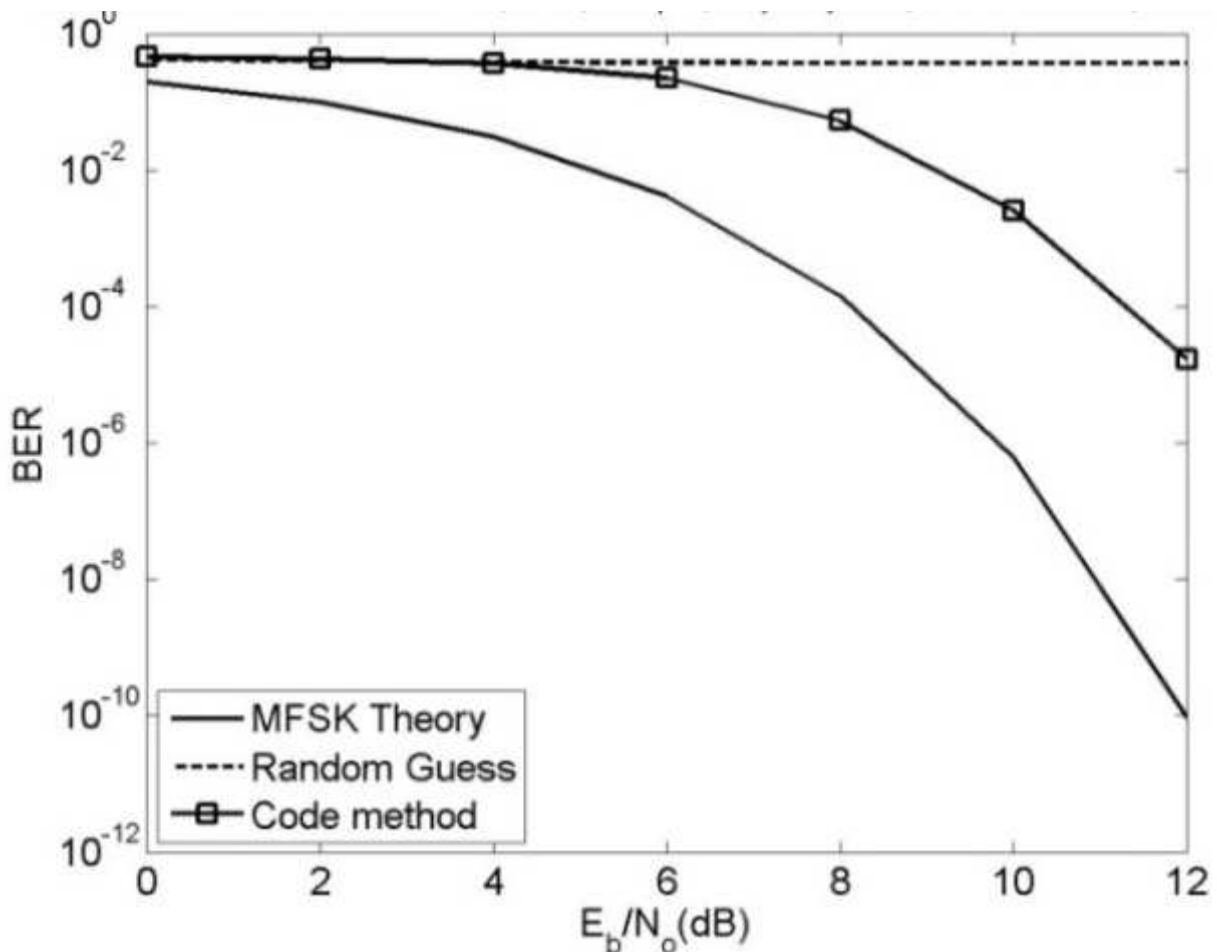

Figure 9. BER performance of fast SESS-FH with 8-ary FSK.

In order to maintain an advantage against an intelligence jammer, it is important that the hopping frequencies be uniformly distributed to ensure that the decoding method employed does not inadvertently introduce an element of predictability in its FH selection. Figure 10 illustrates the example distribution of FH choices vs. E_b/N_o . It can be seen that the FH carrier selection by means of SESS is fairly uniformly distributed suggesting that the majority vote method would perform well against an intelligent jammer.

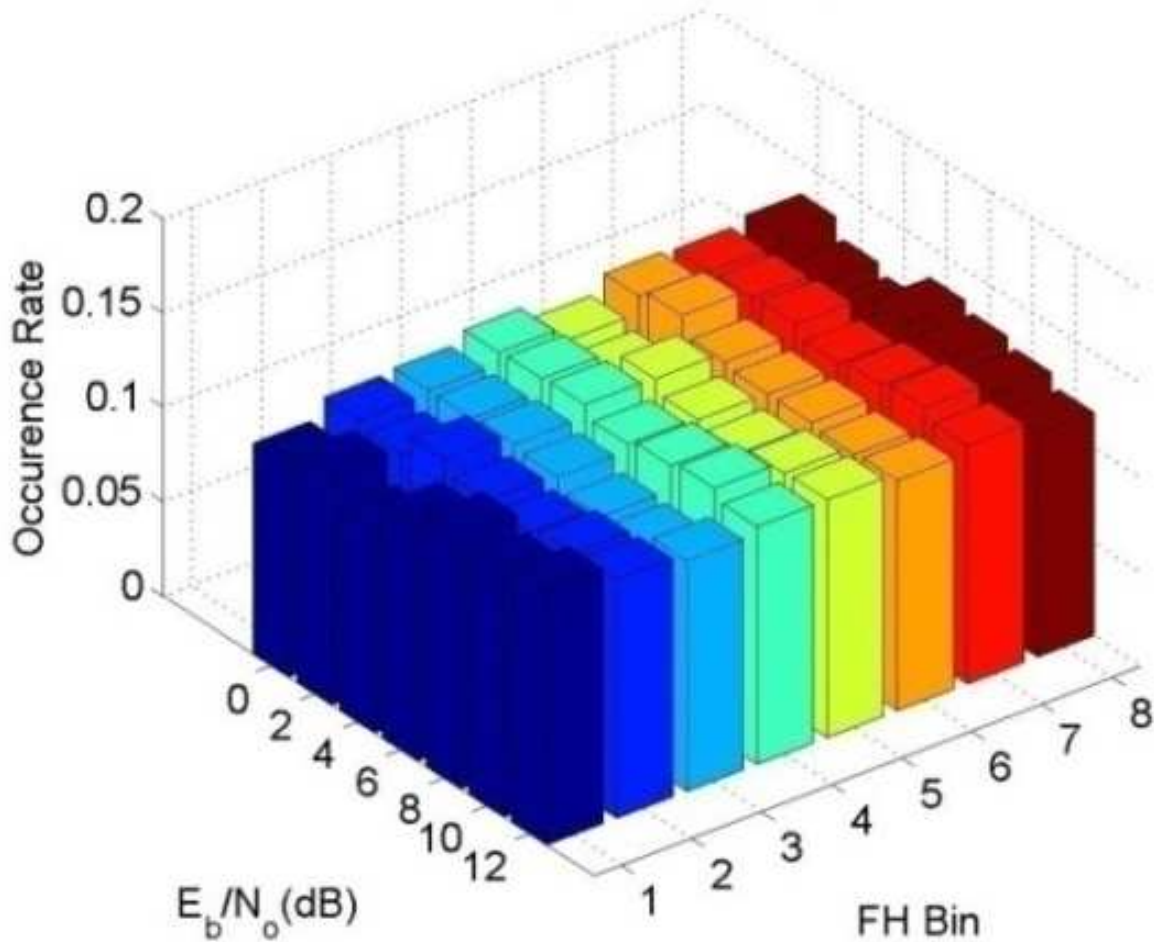

Figure 10. Example carrier frequency distribution of fast SESS-FH.

3.4 Self Encoded Spread Spectrum Multiple-Input Multiple-Output System

SUMMARY OF ACCOMPLISHMENTS (PI Lim Nguyen, Student Sichuan Ma)

We have begun to investigate the performance of SESS-MIMO systems with iterative detection over Rayleigh fading channels. The block diagram of the transmitter of the proposed system is shown in Figure 11, where the rounded corner blocks represent time delay and T_b is the bit interval. Alamouti scheme-based space time block coding (STBC) is utilized to achieve transmit diversity.

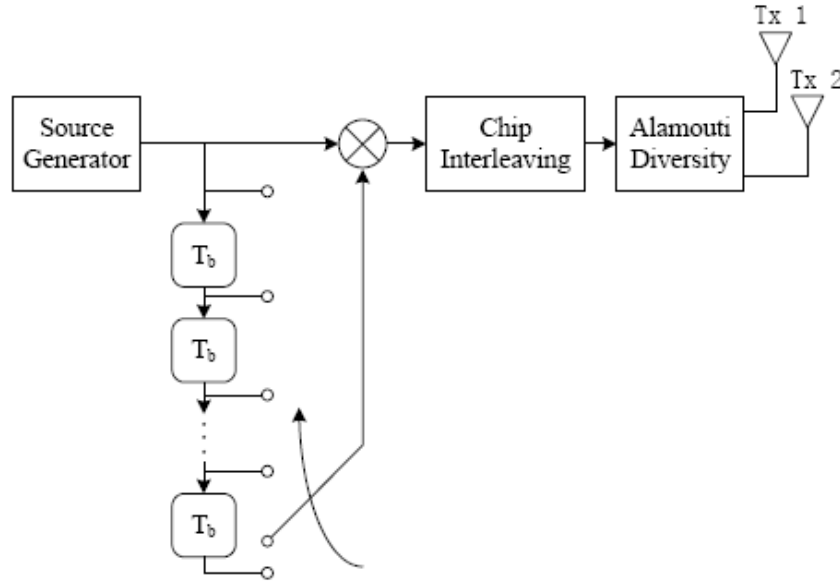

Figure 11. Block diagram of SESS-MIMO transmitter.

The block diagram of the receiver of the proposed system is shown in Figure 12 that includes both feedback detection and iterative detection.

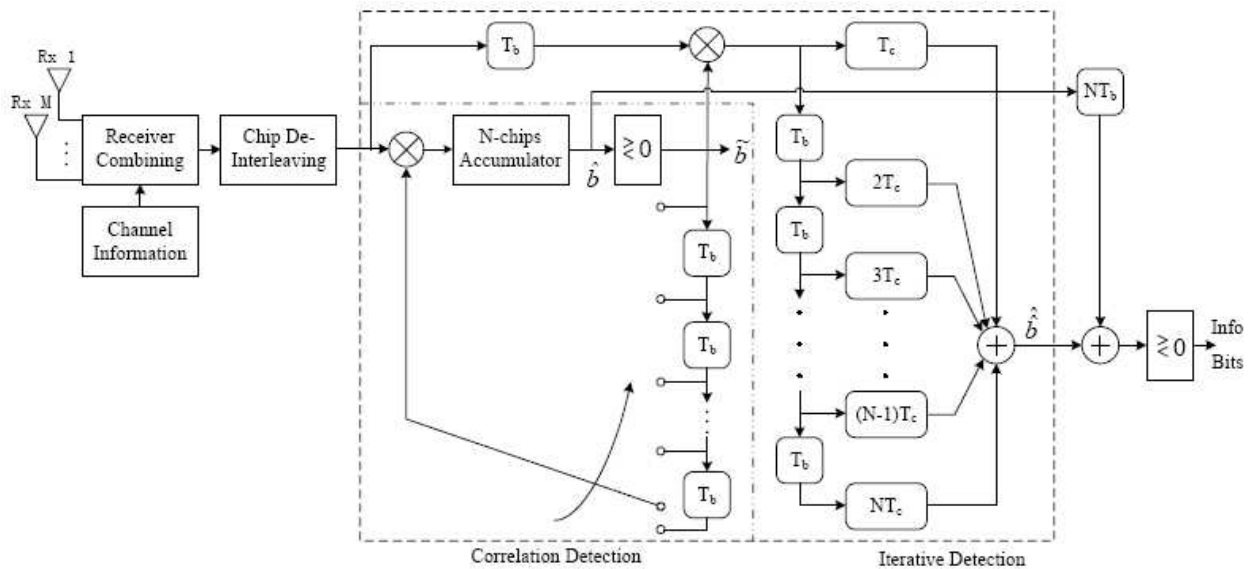

Figure 12. Block diagram of SESS-MIMO receiver.

Iterative detection exploits the inherent time diversity in SESS to achieve robust performance in fading channel. Simulation results over Rayleigh fading channels show that the performance of the proposed SESS-MIMO system is significantly improved due to the diversity gains in time and space. Figure 13 compares the performance of SESS-MIMO system with a conventional MIMO system. The proposed system significantly outperforms Alamouti-based MIMO system: for the 2x2 example there is about a 6.5 dB gain in SNR at 10^{-4} BER. This performance improvement can be attributed to the time diversity introduced by self encoding and exploited with iterative detection.

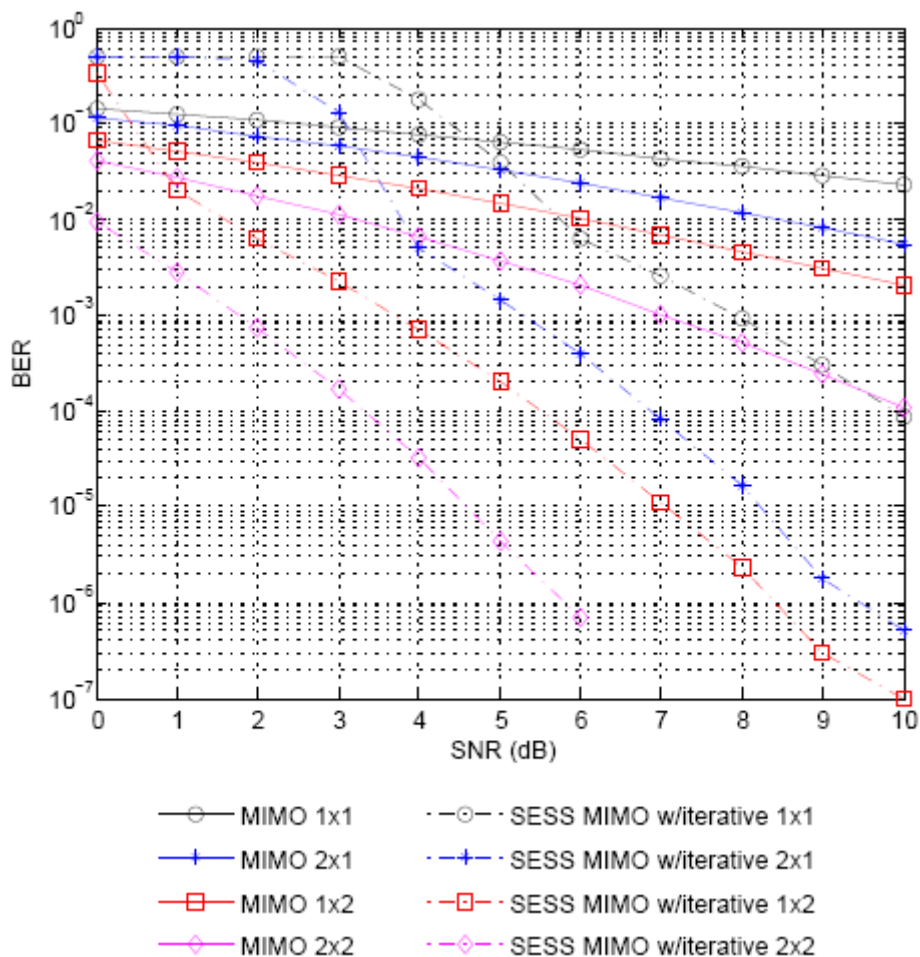

Figure 13. BER performance of SESS-MIMO.

With block chip-interleaving, the time diversity gain can be further increased as shown in Figure 14 that compares the performance of SESS-MIMO with and without interleaving. About 1 dB gain for the 2x2 scenario and 3 dB gain for the 1x1 scenario have been obtained with interleaving. Figure 15 shows the performance of 2x2 SESS-MIMO with iterative detection and interleaving for different spreading lengths. The performance of BPSK system under AWGN and 2x2 Alamouti-based MIMO system under Rayleigh fading was also plotted for comparison. Clearly, the BER of SESS-MIMO improves with the N since the time diversity gain is proportional to the self-encoded spreading length. It can be seen that the combined time and spatial diversities of SESS-MIMO system achieve a 10^{-4} BER at an SNR of only 2.5dB, or 7.5dB gain over Alamouti-based scheme.

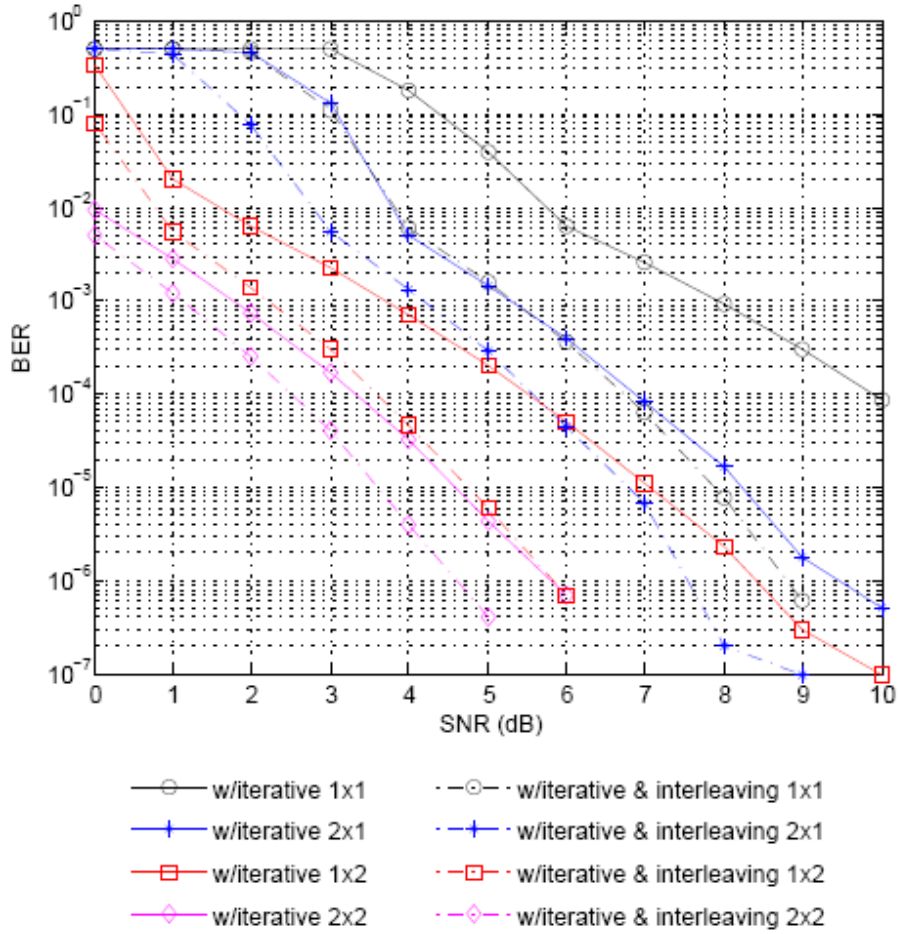

Figure 14. Performance of SESS-MIMO with and without chip-interleaving.

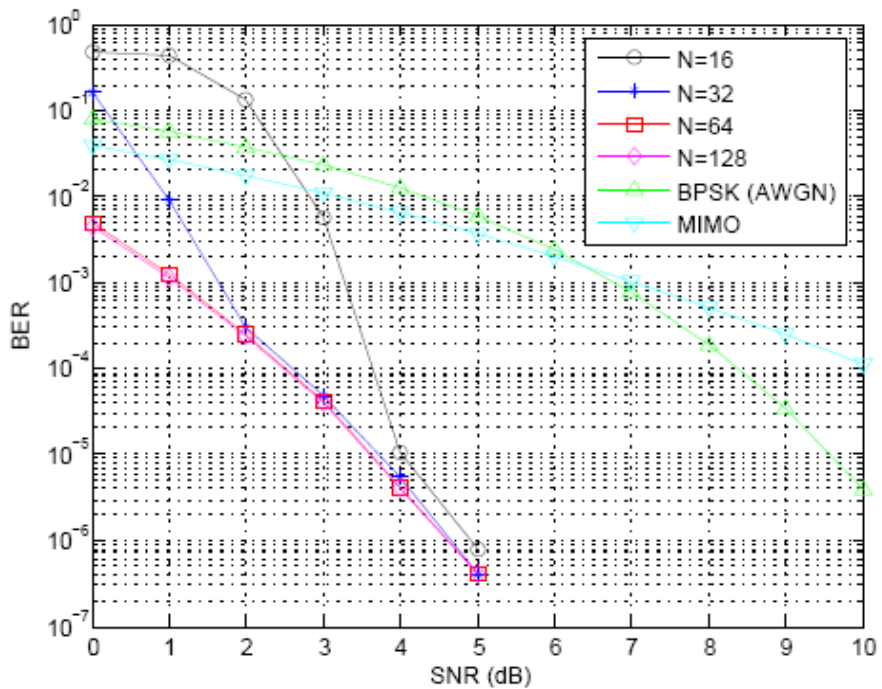

Figure 15. Comparison of SESS-MIMO with BPSK in AWGN and Alamouti-MIMO.

3.5 Multi-Code Self Encoded Spread Spectrum Multiple-Input Multiple-Output System

SUMMARY OF ACCOMPLISHMENTS (PI Lim Nguyen, Student Sichuan Ma)

We have further developed a novel multi-code SESS-MIMO system that not only can achieve the combined time and spatial diversities, but can also double the throughput compared to the previous scheme. Figure 16 illustrates the block diagram of the transmitter employing two independent self-encoded modulators to transmit two symbols per time slot. The receiver block diagram is shown in Figure 17 that employs the iterative detector to exploit the time diversity in addition to the spatial diversity from the multiple receiver antennas.

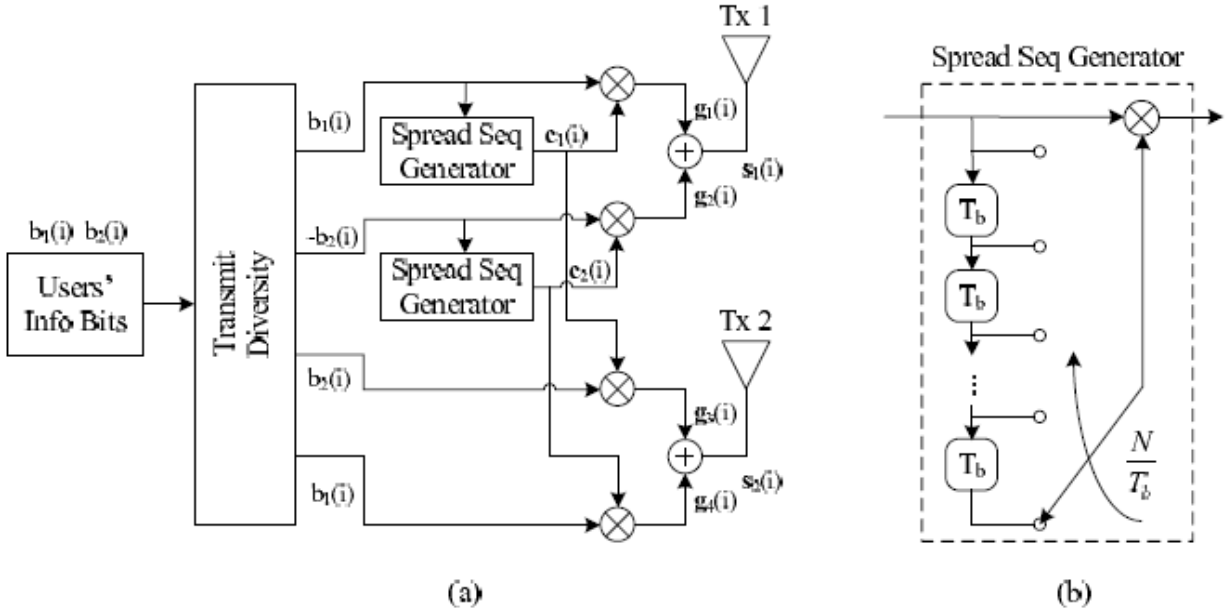

Figure 16. Transmitter block diagram of MC-SESS MIMO.

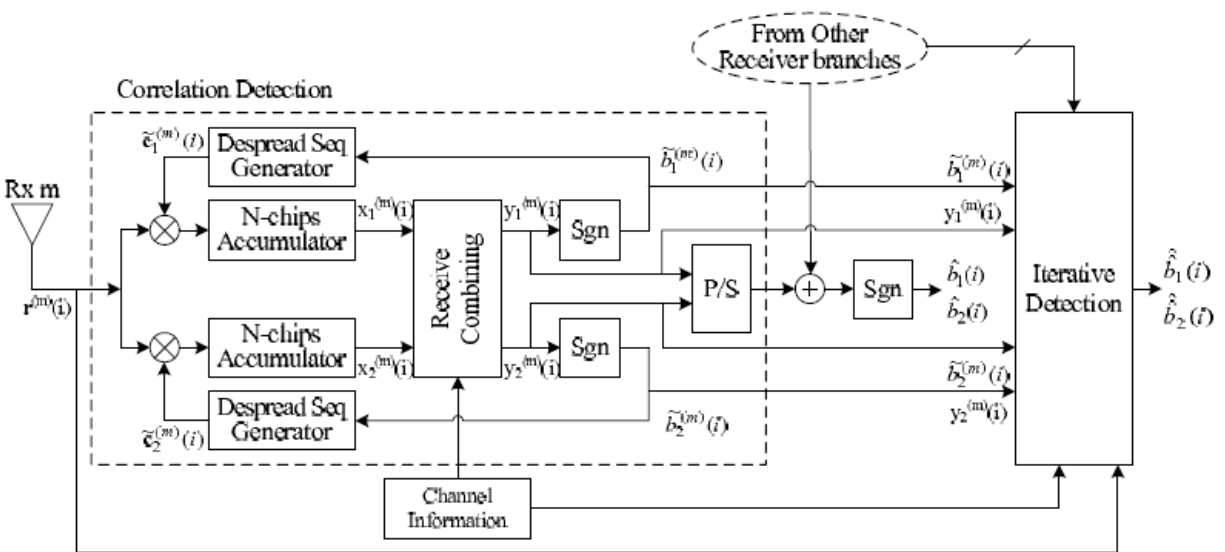

Figure 17. Receiver block diagram of MC-SESS MIMO.

Figure 18 shows the performance of a 2x 2 MC-SESS MIMO system with different spreading lengths. The performance of the Alamouti-MIMO scheme is also plotted for comparison. The system with $N = 32$ performs poorly because the effect of inter-symbol self interference worsens for shorter spreading sequences, which in turn aggravates error propagation. The performance improves with the spreading length (especially at low SNR) because the cross-correlation between the self-encoded sequences approaches zero when N becomes larger. For the example results, it can be seen that the effect of inter-symbol self interference from the sequence cross-correlation is greatly diminished with a spreading length of 256 or longer. At 10^{-4} BER, the proposed system achieves a 6 dB gain over the Alamouti-based MIMO scheme while doubling the system throughput.

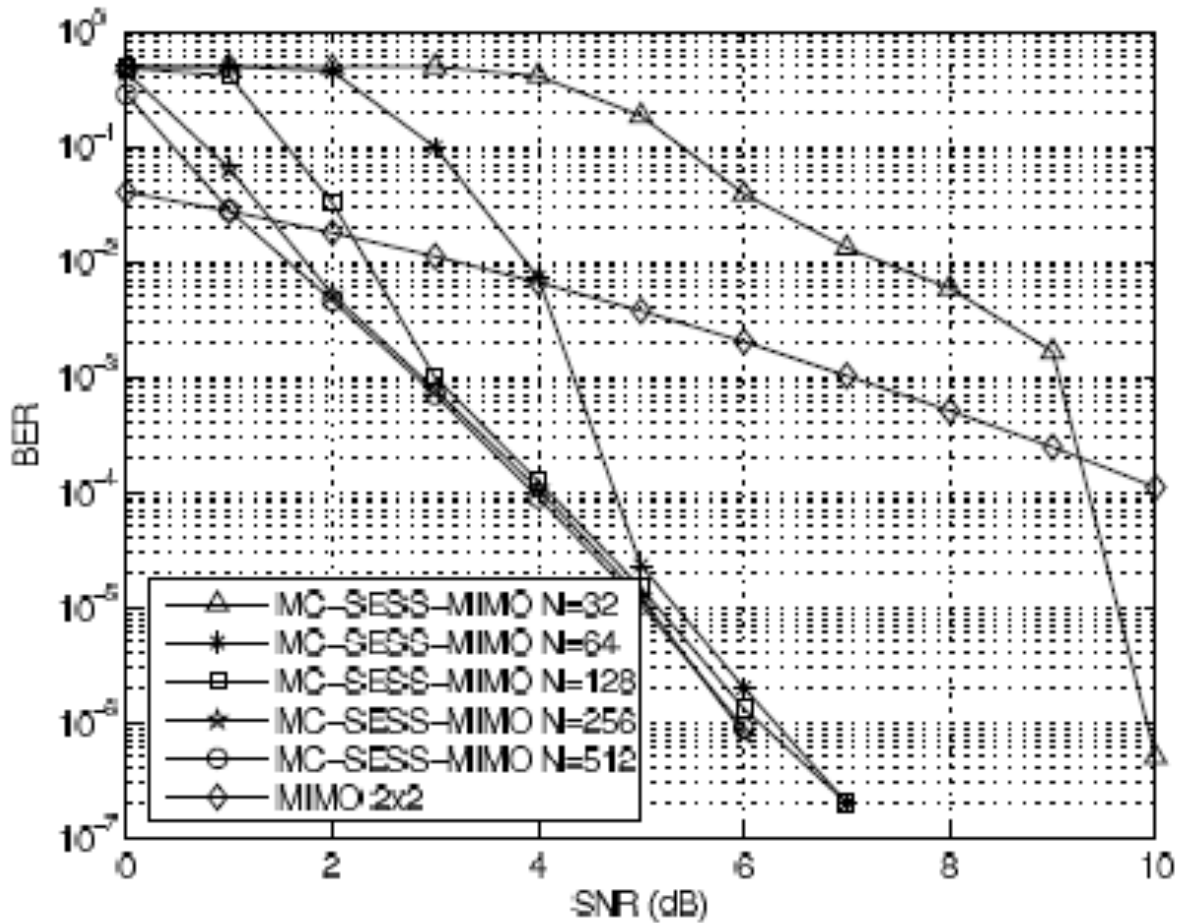

Figure 18. BER performance of MC-SESS MIMO.

3.6 Cooperative SESS in Fading Channels

SUMMARY OF ACCOMPLISHMENTS (PI Won Mee Jang, Student Kun Hua)

Cooperative diversity receives increasing attention as a diversity enabler, whereby several partner terminals around a given mobile terminal form a distributed cooperative network and transmit information collaboratively. We consider SESS cooperative diversity (SESS-CD) communication over fading channels and analyze its performance in fading channels. Expressions for the average bit error rate (BER) are derived and the result is compared with the repetition scheme with maximum ratio combiner (MRC). Iterative detection with SESS-CD receiver is shown to achieve remarkable performance improvement reducing the BER significantly. SESS-CD with iterative detection provides both temporal and spatial diversity while MRC exploits only spatial diversity gain. SESS-CD diversity gain is linked to the square of the received SNR. The SESS-CD BER is inversely proportional to the square term of the SNR while the MRC BER is inversely proportional to the SNR only. We observe that SESS-CD is very stable in highly correlated channels as well as in severely fading channels. SESS combined with CD is promising technique for the future generation of wireless communications.

3.7 Self-Encoded Multiple Access and Convolutional Codes

SUMMARY OF ACCOMPLISHMENTS (PI Won Mee Jang, Student Jong-Hak Jung)

Self-encoded multiple access (SEMA) is an application of SESS in a multi-user and multiple access environment. Due to the random nature of SESS modulation, SEMS provides easy implementation of multi-rate transmissions and multi-level grades of service. These are desirable features in multimedia communications and prioritized heterogeneous networking systems. We developed multiuser convolutional coding directly applicable to SEMA in synchronous downlink as well as asynchronous uplink cellular systems. Convolutional codes with Viterbi decoding have been studied for decades and applied in practical communication systems. In order to improve the performance, we present the shift generator matrix concept that provides lower cross-correlations among users and reduces the MAI in the system for reliable communication.

4. Conclusions

This report has summarized a number of research results relevant to the development and application of self-encoded spread spectrum modulation for robust anti-jamming communications. Notable progresses have been made in pertinent areas and are described in detail in the technical papers that have been referenced in the Appendix. Although the research expenditure from this project has been under-spent to date due to the delay in the recruitment of the graduate research assistants (hence their start-up supports), it is clear that considerable advances have been accomplished since the project was initiated one year ago. The work on coded-sequence self-encoded spread spectrum and synchronization has provided new techniques and tools to further advance information theoretic SESS and its implementation. There is preliminary and promising development on self-encoded fast frequency-hopping spread spectrum that would perform well against an intelligent signal jammer. Significant advances have also been demonstrated in developing SESS-MIMO transmitter and receiver architectures that have been shown to achieve superior and robust performance in fading channels. Novel applications of SESS for multiple access communications and cooperative diversity techniques have been developed that hold promise for the future generation of wireless communications. These progresses combine to enable an improved understanding and capacity toward designing SESS system that will be effective against the detrimental consequences of signal jamming and fading in wireless environments.

Appendix: Publications & Submitted Manuscripts

1. J. H. Jung, W. M. Jang and L. Nguyen, "Self-encoded multiple access multiuser convolutional codes in uplink and downlink cellular systems," to appear in *International Journal of Communications, Network and System Sciences*, 2009.
2. K. Hua, W. M. Jang and L. Nguyen, "Cooperative self-encoded spread spectrum in fading channels," *International Journal of Communications, Network and System Sciences*, vol. 2, no. 2, pp. 91-96, May 2009
3. K. Hua, W. M. Jang and L. Nguyen, "Convolutional coding in cooperative relay systems with spread spectrum," *Proceedings of the 4th International Conference on Networked Computing and Advanced Information Management*, Gyeongju, S. Korea, Sep 2008
4. W. M. Jang, L. Nguyen and M. W. Lee, "MAI and ICI of asynchronous uplink MC-CDMA with frequency offset," *IEEE Transactions on Vehicular Technology*, vol. 57, no. 4, pp. 2164-2179, Jul 2008
5. K. Hua, L. Nguyen and W. M. Jang, "Synchronization of self-encoded spread spectrum system," *Institution of Engineering and Technology (IET) Electronics Letters*, vol. 9, no. 1, pp. 749-751, Jun 2008
6. P. Duraisamy and L. Nguyen, "Coded-sequence self-encoded spread spectrum communications." submitted to Globecom 2009
7. P. Duraisamy and L. Nguyen, "Coded-sequence self-encoded spread spectrum in fading channels," submitted to Milcom 2009
8. S. F. Fahey and L. Nguyen, "Self-encoded spread spectrum communications with FH-MFSK," submitted to Milcom 2009
9. S. Ma, L. Nguyen, W. M. Jang, and Y. Yang, "Self-encoded spread spectrum multiple-input multiple-output system with iterative detection," submitted to Milcom 2009
10. S. Ma, L. Nguyen, W. M. Jang, and Y. Yang, "A Multi-code self-encoded spread spectrum MIMO System," submitted to 2009 Assilomar Conference