

REPORT DOCUMENTATION PAGE			Form Approved OMB NO. 0704-0188		
<p>The public reporting burden for this collection of information is estimated to average 1 hour per response, including the time for reviewing instructions, searching existing data sources, gathering and maintaining the data needed, and completing and reviewing the collection of information. Send comments regarding this burden estimate or any other aspect of this collection of information, including suggestions for reducing this burden, to Washington Headquarters Services, Directorate for Information Operations and Reports, 1215 Jefferson Davis Highway, Suite 1204, Arlington VA, 22202-4302. Respondents should be aware that notwithstanding any other provision of law, no person shall be subject to any penalty for failing to comply with a collection of information if it does not display a currently valid OMB control number.</p> <p>PLEASE DO NOT RETURN YOUR FORM TO THE ABOVE ADDRESS.</p>					
1. REPORT DATE (DD-MM-YYYY) 05-04-2013		2. REPORT TYPE Final Report		3. DATES COVERED (From - To) 1-Oct-2006 - 31-Aug-2012	
4. TITLE AND SUBTITLE Creation of Vapor/Gas Impermeable Coatings for CB Hardening of Existing Structures			5a. CONTRACT NUMBER		
			5b. GRANT NUMBER W911NF-06-C-0167		
			5c. PROGRAM ELEMENT NUMBER 206023		
6. AUTHORS Aleksander Yam, Alex Vainer			5d. PROJECT NUMBER		
			5e. TASK NUMBER		
			5f. WORK UNIT NUMBER		
7. PERFORMING ORGANIZATION NAMES AND ADDRESSES POLYMERright, Inc. 4404 Enterprise Place, Suite C Fremont, CA 94538 -			8. PERFORMING ORGANIZATION REPORT NUMBER		
9. SPONSORING/MONITORING AGENCY NAME(S) AND ADDRESS(ES) U.S. Army Research Office P.O. Box 12211 Research Triangle Park, NC 27709-2211			10. SPONSOR/MONITOR'S ACRONYM(S) ARO		
			11. SPONSOR/MONITOR'S REPORT NUMBER(S) 48875-CH-CDP.5		
12. DISTRIBUTION AVAILABILITY STATEMENT Approved for Public Release; Distribution Unlimited					
13. SUPPLEMENTARY NOTES The views, opinions and/or findings contained in this report are those of the author(s) and should not be construed as an official Department of the Army position, policy or decision, unless so designated by other documentation.					
14. ABSTRACT Objective of this project was to develop a family of coatings that could form a gas impermeable film for expedient encapsulation and CB hardening of existing structures, converting them into COLPRO shelters. The developed coatings are based on POLYMERright's newly developed patented polysulfides (polysulfide polyesters) that were proven to provide excellent impermeability to a broad range of CA simulants. The results were confirmed by the independent testing with live HD agent. The created family of quick-curing and easily-applied coatings forms					
15. SUBJECT TERMS impermeable coating, chemical agent, COLPRO shelter					
16. SECURITY CLASSIFICATION OF:			17. LIMITATION OF ABSTRACT UU	15. NUMBER OF PAGES	19a. NAME OF RESPONSIBLE PERSON Aleksander Yam
a. REPORT UU	b. ABSTRACT UU	c. THIS PAGE UU			19b. TELEPHONE NUMBER 510-252-9090

Report Title

Creation of Vapor/Gas Impermeable Coatings for CB Hardening of Existing Structures

ABSTRACT

Objective of this project was to develop a family of coatings that could form a gas impermeable film for expedient encapsulation and CB hardening of existing structures, converting them into COLPRO shelters. The developed coatings are based on POLYMERight's newly developed patented polysulfides (polysulfide polyesters) that were proven to provide excellent impermeability to a broad range of CA simulants. The results were confirmed by the independent testing with live HD agent. The created family of quick-curing and easily-applied coatings forms gas/vapor-impermeable barrier that rapidly and effectively converts existing structure into a COLPRO shelter.

Enter List of papers submitted or published that acknowledge ARO support from the start of the project to the date of this printing. List the papers, including journal references, in the following categories:

(a) Papers published in peer-reviewed journals (N/A for none)

Received Paper

TOTAL:

Number of Papers published in peer-reviewed journals:

(b) Papers published in non-peer-reviewed journals (N/A for none)

Received Paper

TOTAL:

Number of Papers published in non peer-reviewed journals:

(c) Presentations

Number of Presentations: 0.00

Non Peer-Reviewed Conference Proceeding publications (other than abstracts):

Received Paper

- 01/25/2013 1.00 Aleksander Yam, Alex Vainer. Creation of Vapor/Gas Impermeable Coatings for CB Hardening of Existing Structures, Poster Presentation, Chemical & Biological Defense Science & Technology Conference. 2008/11/12 03:00:00, . . . ,
- 01/25/2013 2.00 Aleksander Yam, Alex Vainer. Creation of Vapor/Gas Impermeable Coatings for CB Hardening of Existing Structures, 2009 Chemical & Biological Defense Science & Technology Conference. . . . ,
- 01/25/2013 3.00 Aleksander Yam, Alex Vainer. New Class of Impermeable Materials, poster presentation, 2010 Chemical & Biological Defense Science & Technology Conference. . . . ,
- 01/25/2013 4.00 Aleksander Yam,, Alex Vainer. New Class of Impermeable Materials, poster presentation, 2011 Chemical & Biological Defense Science & Technology Conference, Las Vegas, NV. . . . ,

TOTAL: 4

Number of Non Peer-Reviewed Conference Proceeding publications (other than abstracts):

Peer-Reviewed Conference Proceeding publications (other than abstracts):

Received Paper

TOTAL:

Number of Peer-Reviewed Conference Proceeding publications (other than abstracts):

(d) Manuscripts

Received Paper

TOTAL:

Number of Manuscripts:

Books

Received

Paper

TOTAL:

Patents Submitted

Patents Awarded

Awards

Graduate Students

<u>NAME</u>	<u>PERCENT SUPPORTED</u>
FTE Equivalent:	
Total Number:	

Names of Post Doctorates

<u>NAME</u>	<u>PERCENT SUPPORTED</u>
FTE Equivalent:	
Total Number:	

Names of Faculty Supported

<u>NAME</u>	<u>PERCENT SUPPORTED</u>
FTE Equivalent:	
Total Number:	

Names of Under Graduate students supported

<u>NAME</u>	<u>PERCENT SUPPORTED</u>
FTE Equivalent:	
Total Number:	

Student Metrics

This section only applies to graduating undergraduates supported by this agreement in this reporting period

The number of undergraduates funded by this agreement who graduated during this period: 0.00
The number of undergraduates funded by this agreement who graduated during this period with a degree in science, mathematics, engineering, or technology fields:..... 0.00
The number of undergraduates funded by your agreement who graduated during this period and will continue to pursue a graduate or Ph.D. degree in science, mathematics, engineering, or technology fields:..... 0.00
Number of graduating undergraduates who achieved a 3.5 GPA to 4.0 (4.0 max scale):..... 0.00
Number of graduating undergraduates funded by a DoD funded Center of Excellence grant for Education, Research and Engineering:..... 0.00
The number of undergraduates funded by your agreement who graduated during this period and intend to work for the Department of Defense 0.00
The number of undergraduates funded by your agreement who graduated during this period and will receive scholarships or fellowships for further studies in science, mathematics, engineering or technology fields: 0.00

Names of Personnel receiving masters degrees

NAME

Total Number:

Names of personnel receiving PHDs

NAME

Total Number:

Names of other research staff

NAME

PERCENT SUPPORTED

FTE Equivalent:

Total Number:

Sub Contractors (DD882)

1 a. Battelle Memorial Institute

1 b. 505 King Avenue

Colombus OH 43201

Sub Contractor Numbers (c):

Patent Clause Number (d-1):

Patent Date (d-2):

Work Description (e): Evaluation of the coating with live HD agent

Sub Contract Award Date (f-1): 4/30/2012 12:00:00AM

Sub Contract Est Completion Date(f-2): 8/31/2012 12:00:00AM

Inventions (DD882)

Scientific Progress

Technology Transfer

1. FOREWORD

Prior to the commencement of the project, POLYMERright has created and patented (US patents #7,087,708 and # 8,158,726) a new class of polymers, poly(thioesters), or polyester polysulfides (PEPS). Various types of derivatives of these compounds (many of them are liquid under the ambient conditions) can be cured into solid materials. These materials could be used as coatings, sealants, castable plastics, etc. Polysulfide-based polymers are known to be one of the most chemically-resistant and gas impermeable materials. POLYMERright's newly developed patented PEPS theoretically could be expected to have even better impermeability than classic polythioethers. After evaluation of the properties of the solidified PEPS resins, their excellent resistance to many different active aqueous and non-aqueous agents, as well as their impermeability to many gases and vapors were confirmed.

When we were present at the COLPRO Workshop in Panama City, FL in January 2005, we saw a presentation "Expedient Encapsulation: Structural Protective Coatings" made by Carrie A. Delcomyn from Applied Research Associates, Inc., AFRL/MLQL, Tyndall AFB, FL. In this project, a team of researchers from Tyndall and Eglin AFB, under the direction from DTRA/CBD Joint S&T Office, has evaluated several commercial coatings for their ability to rapidly encapsulate existing structure to convert these structures into collective chemical and biological shelters.

From our point of view, commercial architectural coatings could not (and did not) provide sufficient protection for the structures converted into the COLPRO shelters. Most of them are specifically designed to be air-permeable. The tested silicone coating uses inappropriate material: silicone is one of the most permeable classes of polymers. The presented results of evaluation of three types of commercial coatings showed that coating interior of shelter achieved a 69% reduction in leakage. Such level of leakage reduction is significant. However, we consider it to be insufficient for such a critical application as protecting the personnel in improvised COLPRO shelters.

Based on the analysis of the Applied Research, Inc.'s project, in response to the U.S. Army Research Office Broad Agency Announcement W911NF-05-R-0003, "Solutions for Physical Science and Technology, Chemical and Biological Defense Program", POLYMERright suggested developing a special coating that targets impermeability of the films to Chemical Agents and their simulants. After a proposal from POLYMERright was submitted and evaluated, contract #W911NF-06-C-0167 was signed. The current report discusses the findings developed under this contract.

2. TABLE OF CONTENT

1.	FOREWORD	1
2.	TABLE OF CONTENT	2
3.	PROJECT OBJECTIVE	3
4.	SUMMARY OF THE RESULTS	4
4.1	Phase 1: Experimental Setup and Choice of the Resin	4
4.1.1	Permeability Testing Setup	4
4.1.2	Permeation Testing Procedure	6
4.1.3	Synthetic Procedure	7
4.1.4	Production of films	9
4.1.5	Phase 1 Conclusions:	11
4.2	Phase 2 - Formulation of Coatings	12
4.2.1	Step 1. Choice of a Curing Agent	12
4.2.2	Step 2. Formulating Additional Reactive Components on the Resin Side	14
4.2.3	STEP 3. Formulating Plasticizers	14
4.2.4	STEP 4. Formulating Fire Retardants	14
4.2.5	STEP 5. Formulating Catalysts	15
4.2.6	STEP 6. Application Technique and Development of Protective Properties Kinetics	15
4.2.7	Phase 2 Conclusions	16
4.3	Phase 3. Evaluation of the Properties of Films	17
4.3.1	Duration of Protection vs. Film Thickness	18
4.3.2	Duration of Protection vs. Time after Application	18
4.3.3	Thermal Stability and Low Temperature Properties	18
4.3.4	Absorptive/CA Sequestration Properties	18
4.3.5	Duration of Protection against Liquid CEES and Other Compounds	19
4.3.6	Phase 3 Conclusions	20
4.4	Phase 4. Evaluation of the Air Retention Properties of Thioshield™ Coating	20
4.4.1	Step 1. Creation of a Technique to Apply the Coating to Large Surfaces	20
4.4.2	Step 2. Construction of the Testing Shed	21
4.4.3	Step 3. Evaluating the Air Loss of the Testing Shed	22
4.4.4	Step 4. Evaluating the Removability of the Coating from Different Substrates	24
4.4.5	Phase 4 Conclusions	25
4.5	Stage 5. Work Targeting Hammer Program	25
4.5.1	Phase 5 Description	25
4.5.2	Phase 5 Conclusions	28
4.6	Stage 6. Testing of the Coating with Live HD Agent	28
4.6.1	Phase 6 Conclusions	29
5.	OVERALL PROJECT CONCLUSIONS AND RECOMMENDATIONS	29
5.1	Conclusions and Recommendations Re. Collective Protection	29
5.2	Conclusions and Recommendations Re. Hazard Mitigation	30
6.	APPENDIX 1. Test Report for POLYMERright, Inc. Coating Agent Testing	31

3. PROJECT OBJECTIVE

Current CB collective protection shelters are expensive and difficult to assemble constructions, intended for one purpose: to protect personnel during a CB attack. Such a high specialization of these structures makes them a big liability in the logistics of field operations, limiting the number of fielded CB COLPRO systems at forward locations. One of the ways to solve the logistics problem of organization of collective protection of personnel at forward locations is the conversion of existing permanent and/or temporary structures into protected shelters.

In order to provide the Armed Forces and Civil Defense organizations with the means to expediently convert a wide variety of existing constructions into COLPRO shelters, POLYMERright, Inc. proposes to create a family of reliable and easy to use gas impermeable coatings. Encapsulating the existing permanent and temporary structures into such coatings will enable their rapid and easy conversion into protected CB shelters.

There are two main contributors to the gas permeability of a sealed structure:

- Permeability of constriction materials, and
- Leakage through the gaps, joints, and cracks of the structural elements¹.

The contribution each of these factors into the permeability of the structure depends on the type of the structure. For example, the permeability of materials is the key factor in the case of the temporary constructions, such as tents. In the case of the permanent brick or stucco constructions the permeability through gaps, joints, and cracks will be the major contributor.

Based on these considerations and summarizing previous POLYMERright's experience, the targeted coatings, while in liquid form, will have the following combinations of properties:

- Two components with sufficient storage stability, (minimum one year, with a target of two years),
- Pot life after mixing of the components in a container in excess of 4 hours,
- Fast curing after application (4-8 hours),
- Suitable for the application by conventional rolling, brushing and spraying equipment,
- Ability to be applied over a wide variety of materials (wood, steel, drywall, ceramic, natural and synthetic fabrics, common plastics, etc.),
- Error tolerant when applied by an averagely-skilled crew,
- No requirements for complex logistics associated with the storage, transportation, application, and disposal.
- Zero content of HAP and heavy metals,
- No-VOC formulation (<25 g/L in California, < 50 g/L the rest of the US)

¹ C.A. Delcomyn, "Expedient Encapsulation: Structural Protective Coatings", JSTO Protection Capability Area, Shelter Materials and Systems Workshop, Panama City, FL, January, 2004

The cured film properties that are necessary for the successful products include:

- Maximum impermeability to the whole spectra of the chemical and biological agents,
- Maximum impermeability to atmospheric gases, ability to maintain positive pressure inside an encapsulated structure,
- Ability to effectively seal the gaps in joints and cracks,
- Flexibility over 30% as tested by 1/8" mandrel bending,
- Resistance to water, DS2² decontamination agent, agents GD and HD, and
- Sufficiently low adhesion to all construction substrates so that the film could be easily removed.

Thus, the objective of this project was to develop a family of coatings that form a gas impermeable film for expedient encapsulation and CB hardening of existing structures, converting them into COLPRO shelters.

4. SUMMARY OF THE RESULTS

In the course of the project POLYMERright has completed several phases of work.

4.1 Phase 1: Experimental Setup and Choice of the Resin

4.1.1 Permeability Testing Setup

Before the inception of the project, we had evaluated several types of permeability testers currently present on the market. Unfortunately, these instruments either did not have sufficient sensitivity, or were excessively expensive, with the price range \$65,000 - \$80,000. Also these overly expensive instruments were produced abroad (in Switzerland and China), and the producers of these devices did not have sufficient technical support in the USA to guarantee uninterrupted operation.

Therefore, we decided to order a custom-made permeation cell from DialAct Corp. (Fremont, CA), a local company that manufactures custom metal and plastic parts for the hi-tech and medical industries. As the basis for the design of this cell we took a permeation cell used by the group of scientists from Applied Research Associates, Inc. and Air Force Research Laboratory in Tyndall AFB who study the existing coatings that can be used to expediently convert existing structures in chem/bio shelters. We'd like to express our gratitude to Mike Henley, Carrie Delcomyn and other members of this group for the information they shared with us on their experimental setup. The schematics of the permeation cell produced for POLYMERright are shown in Fig. 1.

²Decontamination Solution 2(DS2) is a decontamination composition currently used by the United States military against a variety of warfare agents. DS2 contains 70% diethylenetriamine, 28% ethylene glycol monomethyl ether and 2% sodium hydroxide. However, DS2 is extremely corrosive, particularly in large amounts.

The Tyndall group, as well as majority of other researchers^{3,4} used a gas chromatograph (GC) to serve as an indicator and detector of the breakthrough of the agent through the membrane that is being tested. GC determines the amount of half-mustard that had passed through the films relatively easily. Unfortunately, POLYMERright does not possess a GC, and a purchase of a GC was not budgeted in this project. However, POLYMERright has a highly sophisticated Thermo-Nicolet Protégé 460 FTIR spectrophotometer. Half-mustard and majority of other imitants have very distinct IR spectra with several bands that are very strongly expressed. Therefore, if combined with a sensitive gas cell, an FTIP spectrophotometer can serve as a very effective indicator for the presence of half-mustard and other CA imitants.

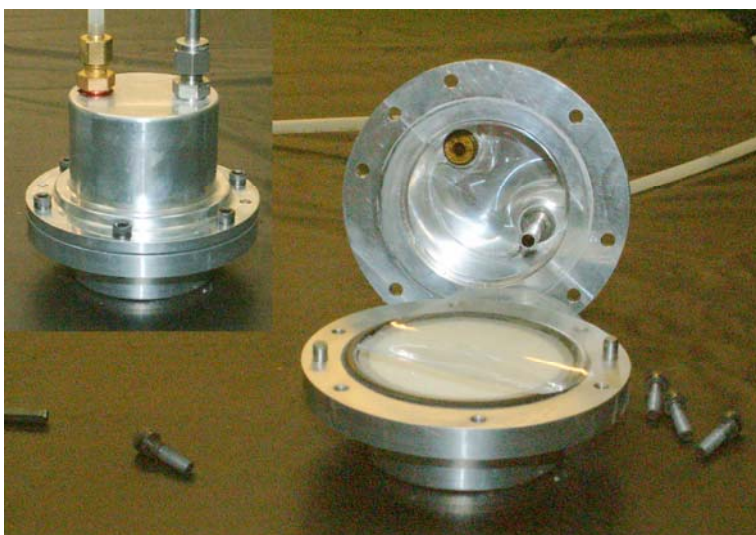

Fig.1. Permeation cell

The permeability testing setup that was ordered by POLYMERright includes a highly sensitive 10 M Gas Cell made by Thermo Nicolet. This cell has a 10 meter laser beam path. It is designed to work with Thermo-Nicolet spectrophotometers. It can be very easily mounted on the instrument prior to a test and dismantled after the test is completed. The whole permeation testing setup is shown in Fig. 2. It is built strictly according to ASTM F 739-99A, Standard Test Method for Resistance of Protective Clothing Materials to Permeation by Liquid or Gases Under Conditions of Continuous Contact. 50 ml/min of dry nitrogen passes through the permeation cell into the gas cell of spectrophotometer. After leaving the spectrophotometer, nitrogen with half-mustard vapors passes through a gas washing bottle filled with the 1% solution of potassium permanganate in 5% sulfuric acid, where half-mustard is neutralized before the carrier gas is released.

³ K.L. Donahue, Chemical and Biological Barrier Materials for Collective Protection Shelters, Soldier and Biological Chemical Command, Natick, 508 233-5202

⁴ http://www2.dupont.com/Personal_Protection/en_US/tech_info/index.html

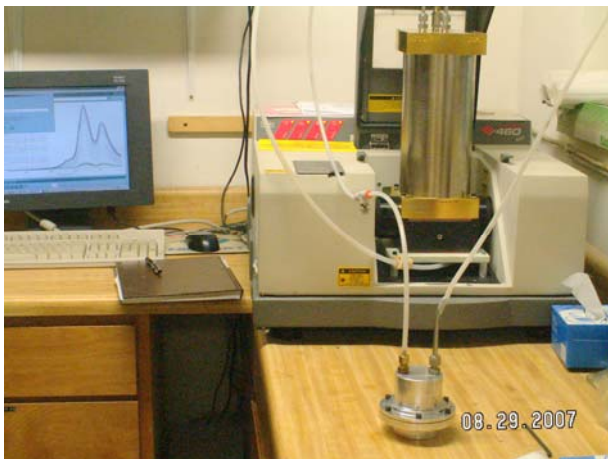

Fig. 2. Permeation testing setup

4.1.2 Permeation Testing Procedure

POLYMERright has developed and consistently used through the whole project the following permeation testing procedure:

First, the spectrophotometer's gas cell is thoroughly flushed with dry nitrogen in order to displace all the carbon dioxide and atmospheric moisture from the system. A background spectrum is taken immediately prior to the inception of the test, and then the permeation cell is connected to the gas cell of the spectrophotometer.

In order to test the permeability of films to the CA simulant **vapors**, 0.5 ml of simulant is placed on the bottom of the cell below the film that is being tested, and 50 cc/min of nitrogen is passed through the permeation cell above the film directly into the spectrophotometer.

In order to test the permeability of films to the CA simulant **liquid**, the permeation cell is turned upside down, 0.5 ml of half-mustard is placed on the film that is being tested, and 50 cc/min of nitrogen is passed through the permeation cell below the film directly into the spectrophotometer.

The first spectrum is taken immediately after the cell is connected, and a spectrum is taken every half hour thereafter. POLYMERright had created a macro that allows taking spectra automatically, without any human interference.

The moment the simulant breaks through a testing film is indicated by the arrival of the characteristic simulant's bands in the spectrum of nitrogen that passes through the permeation cell. Testing of a film is terminated when the height of these peaks reaches maximum, indicating that the simulant's permeation had reached a steady state regime.

After the testing of a film is concluded, the most characteristic band of the simulant (for half-mustard spectrum it is a peak 2977 cm^{-1}) is separated, and the heights of all peaks

are measured and plotted against the time elapsed since the inception of the test. A typical picture obtained at the end of a permeation test is shown in Figure 3.

It must be noted that the chosen load of simulant equals $\sim 254 \text{ g/m}^2$, which is overwhelmingly high. We have chosen such a high load in order to definitely achieve a breakthrough of the simulant through the film in every experiment. This decision proved to be correct, as, at the later stages of development, the Michael Henley's group at Tyndall AFB has attempted to independently verify POLYMERright's results under a standard 10 g/m^2 load of CEES. Unfortunately, this test confirmed the excellent protective properties of the POLYMERright's material, it did not allow quantifying them. The test had to be terminated after 1 week without any indication of penetration of CEES through the film.

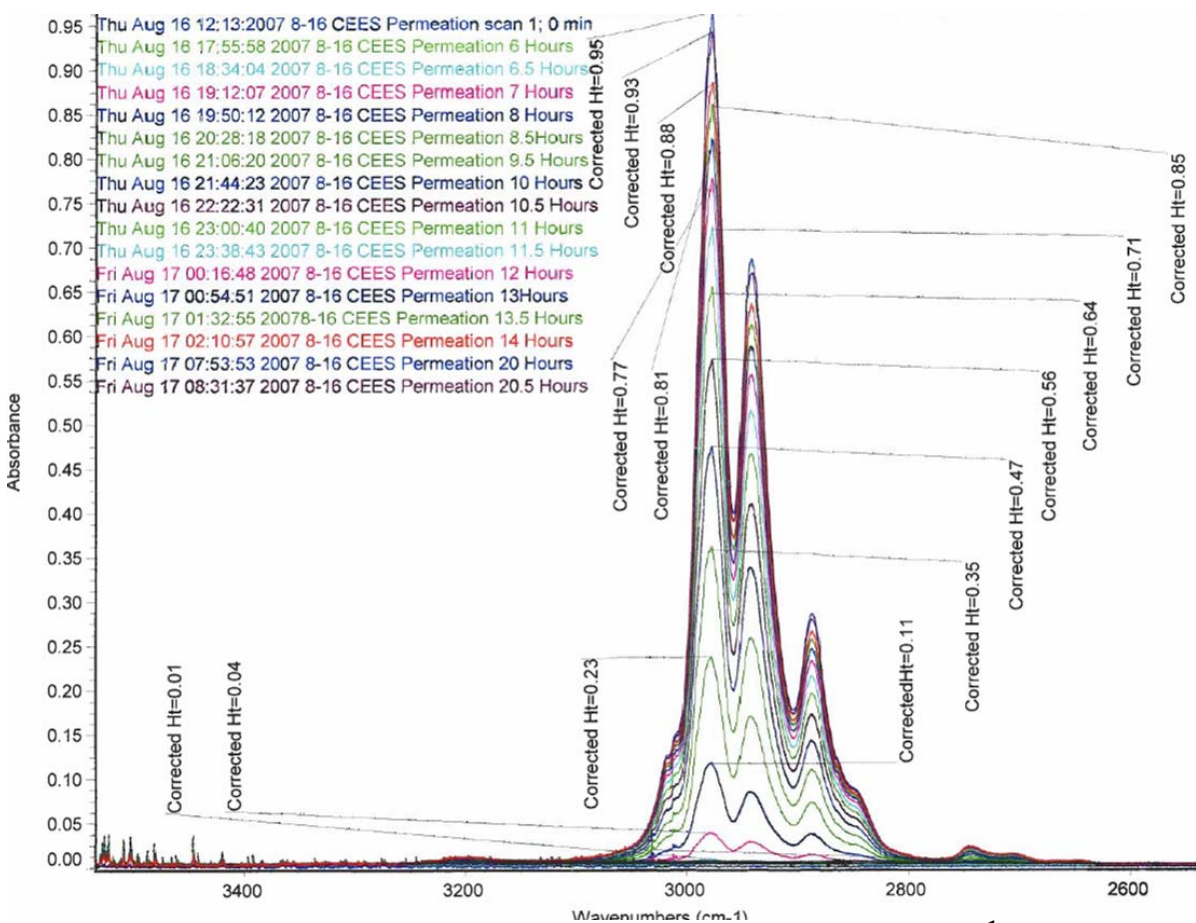

Fig. 3. Typical spectra of a film testing experiment ($2800\text{-}3100 \text{ cm}^{-1}$ band)

4.1.3 Synthetic Procedure

All polysulfide resins were synthesized in a 4-necked glass kettle equipped with a stirrer, argon or vacuum nipple, separation funnel for addition of reactants and a thermocouple well for precise temperature control. The kettle was placed into a heating mantle with temperature control, and connected to a Friedrich condenser that was continuously cooled

down to -5°C . Condensate was collected into a glass-jointed graduated cylinder. A typical synthetic procedure setup is shown in Figure 4.

All the syntheses were conducted at $80\text{-}140^{\circ}\text{C}$, either under vacuum or under argon. The chemical reactions were monitored using a Thermo-Nicolet Protégé 460 FTIR spectrophotometer. In the course of the reaction, the bands $1650\text{-}1725\text{ cm}^{-1}$ (that characterize the carbonyl group of a carbonic acid) and 1782 and 1865 cm^{-1} (that characterize the carbonyl group of an organic anhydride) disappear, and a band $1735\text{-}1750\text{ cm}^{-1}$ (that characterizes a carbonyl of an ester group) increases in size.



Fig. 4. Synthesis experimental setup

The structures of some resins produced as a result of the syntheses were confirmed by titration of their reactive terminal groups. This work was conducted on a Mettler-Toledo DL-55 titrator. It must be noted that, as all the produced resins were new compounds that had never been synthesized before, the methods for their analyses had to be developed and validated for every terminal group.

Unfortunately, all the attempts to monitor the esterification reaction by measuring the concentration of hydroxyl groups using titration according to ASTMs E 335-96⁵, D 4274-99⁶ and E 1899-77⁷ failed due to the incompatibility of reagents and the interference of the polysulfide-containing precursors. All other attempts to measure hydroxyls

⁵ ASTM E-335-96, Standard Test Method for Hydroxyl Groups by Pyromellitic Anhydride Esterification

⁶ ASTM D 4274-99, Standard Test Method for Testing Polyurethane Raw Materials: Determination of Hydroxyl Numbers of Polyols

⁷ ASTM E 1899-77, Standard Test Method for Hydroxyl Groups Using Reaction with p-Toluenesulfonyl Isocyanate and Potentiometric Titration with Tetrabutylammonium Hydroxide

concentration of resins in polysulfide polyesters using other wet chemistry procedures described in a monograph that describes various methods of analysis of hydroxyl groups⁸ also failed. It must be noted that ASTMs E 335-96 worked well enough to monitor the formation of polysulfide polyethers.

Measuring the volume of condensed volatile by-products that collected in the glass-jointed graduated cylinder connected to a condenser provided additional means to monitor the production of polysulfide polyester, polyethers and poly(ether-esters).

4.1.4 Production of films

During Phase I we have also developed methods to convert these resins into polymeric films using different chemical mechanisms. POLYMERright has produced two types of resins that had to be tested for their impermeability to half-mustard. The first type of resins formed a film after they were mixed with a hardener (these resins can serve as the basis for two part coatings), and the second type of resins cured after they were exposed to the atmospheric moisture (these resins can serve as the basis for one part coatings).

The reactive mixture (resin) that had to be tested for film impermeability was spread special release paper using a 10 mil drawdown applicator. After the material cured (usually overnight) the ready films could be easily separated from the release paper, and testing specimens were cut out of them (See Fig.5).

It must be noted that some materials do not form uniform flawless films, but instead show “fish eyes”, “orange peel” and other frequently encountered film defects. For such resins, in order to eliminate film imperfections, the necessary preliminary formulating steps had to be undertaken. These steps involved testing different additives that modify the surface tension of the resins in the process of curing. In most cases, such steps were sufficient to provide good quality films for testing.

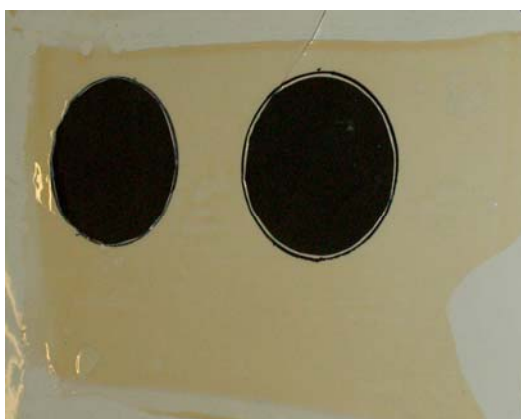

Fig.5. Photo of a film on a release paper

⁸ Stig Veibel, The Determination of Hydroxyl Groups, Academic Press, London and New York, 1972

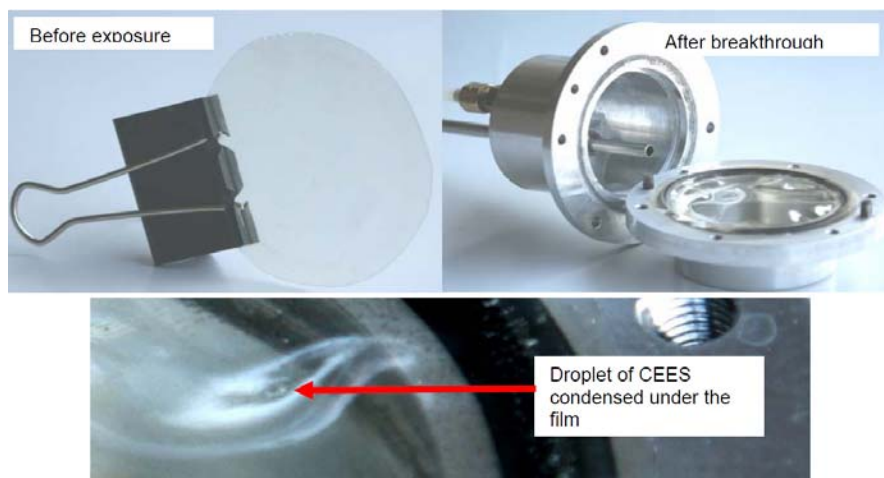

Fig 6. Typical Film before and after Exposure to CEES Vapors

We have created over 30 films from different polysulfide-containing resins and evaluated polymers produced from these resins, including half-mustard and moisture permeability of the films formed. Permeability testing of the first film specimens revealed that

- polysulfides provide noticeable protection against breakthrough of half-mustard in vapor phase, but this protection strongly depends on the structure of the polymer, varying from 1 hour for some polymers to 18 hours for others (as measured for 10 mil films)
- films produced by polyurethane mechanism provide better protection against breakthrough in vapor phase than films produced by polysiloxane mechanism
- breakthrough through polysulfide films occurs only after the films significantly swell in the half-mustard vapors (as a comparison, half-mustard penetrates through polyethylene film practically immediately (after 1-3 min.), but the film remains visually unchanged).
- There is no evident correlation between moisture and half-mustard permeability of polysulfide-based films, however all the polymers with good CEES impermeability properties have demonstrated very low moisture permeability.

We have compared S_2 and S_3 resins and compared polyester vs. polyethers and hybrid polyester/polyether with chemical structures (1), (2) and (3). We have found out that S_2 – hybrids and S_3 – esters provide the best CEES impermeability. They had demonstrated equally good protective properties. However, as the hybrids are more difficult to produce, and their mechanical properties are worse, we have selected to use S_3 – esters.

Polyether polysulfide



Polyester polysulfide

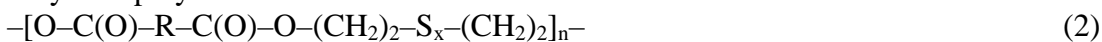

Hybrid (polyester/polyether) polysulfide

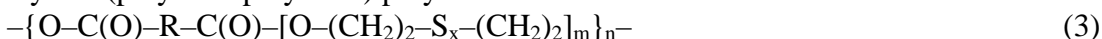

Thialkoxysilane-terminated resin

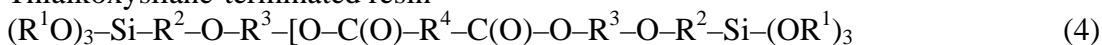

Where x = 2,3, or 4

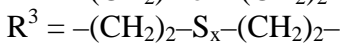
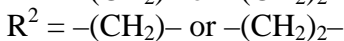
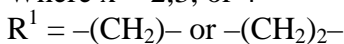

R^4 = a segment of any dibasic carbonic acid located between the carboxylic groups

A broad range of commercially available dibasic acids and their anhydrides (that included adipic acid, phthalic acid, maleic anhydride, fumaric acid, succinic anhydride, fatty acid dimers, etc) were tested as acidic component used in the formation of polyesters.

Based on superior barrier properties, reproducibility of results, and ease of synthesis, we have selected S_3 esters made with adipic acid as a final choice of the basic resin for the future coatings. We have tested ~10 mil films produces with this resin, and the best one (where the resin was cured with HDI trimer) has demonstrated full protection against CEES vapors for 7 hours @10 mil, and >10 days @75 mil.

We have produced several silane – terminated resins with formula (4) and attempted to create films from them. Unfortunately, these tests were not successful. Thicker films did not cure completely due to impermeability of the crusts that formed on the surface of the resins. This is due to the inability of alcohol (which forms in the process of curing) to evaporate through cured crust. This prevents complete curing of a film. Thus we have eliminated trialkoxy-silane terminated resins from the list of potential candidates for the basic resin of the future coating.

We have also made an attempt to produce polysulfide containing resins that can be cured using epoxy chemistry. However the three resins that we have synthesized didn't produce films with useable properties, and all further attempts to utilize epoxy chemistry were abandoned.

4.1.5 Phase I Conclusions:

- One-part impermeable coatings are not viable for this development
 - Radical polymerization does not work as disulfide is effective radical scavenger
 - Solvent- and water-borne formulations cannot be used, as solvent and water are slow to migrate out of the film due to material's impermeability
 - Atmospheric moisture-curable resins with low permeability provide too short protection in thin films, and cannot form impermeable dense, thick films
- Two-parts polysulfide-based coating is the way to continue development:
 - Epoxy chemistry does not allow a combination of high sulfidity and low viscosity
 - Reactive double bond/amine chemistry does not allow sufficient pot life

- Polyurethane chemistry allowed converting polysulfide polyester resins with high sulfidity and reasonable application properties into films with high impermeability (7 hours @ 10 mil, and >10 days @ 75 mil)
 - Polyurethane based polysulfide coatings are the choice for further development
 - The resins (5) were chosen for consequent formulating efforts. Later all the test were conducted on the resin where n=1. This choice was made on the basis of better physical properties of this resin.
- HO-(CH₂)₂-S₃-(CH₂)₂-[O-C(O)-(CH₂)₆-C(O)-O-(CH₂)₂-S₃-(CH₂)₂]_n-OH, (5)
where n=1 – 2
- Adipic acid based resins provided better films than the resins based on other dibasic acids
 - S₃ segments provided significantly better impermeability than S₂, while S₄ resin is unstable
 - Polysulfide polyesters provided better protection than polysulfide polyethers
 - Impermeability of polysulfide polyester films was similar to that of hybrid polysulfide poly(ethers/esters), but the polysulfide polyester resins are much easier and less expensive to produce and their mechanical properties are far superior.

4.2 Phase 2 - Formulation of Coatings

The formulating efforts were based on a resin with formula (5) and molecular weight of 490-500 (n=1). This resin is further referred to as Adipic Di-Ester of Dihydroxyethyl-Trisulfide (ADEDT). We have confirmed the robustness of ADEDT synthesis and consistency of results by conducting over 20 permeability tests for the similar films with optimized protective properties, which were produced from different production batches of resin. All the tests demonstrated consistently good results.

The production of ADETS was eventually licensed by a major specialty chemicals company with more than 9 billion in annual sales, Chevron Phillips Chemicals LP (CPChem). All the following tests were conducted on ADETS produced by CPChem in their pilot production plant.

The formulation of the coating involved the following formulation steps.

4.2.1 Step 1 – Choice of a Curing Agent

After Phase I, only aliphatic isocyanates were considered as curing agents for the coatings, as the reaction of ADEDT with aromatic isocyanates (which are also considered to be carcinogenic and much less stable to UV and sunlight) was so rapid that it could not be controlled.

The following isocyanates were tested as potential curing agents: isophorone diisocyanate (IPDI), IPDI trimer (TIPDI), hexamethylene diisocyanate (HDI), HDI trimer (THDI),

hydrated diphenylmethane diisocyanate (HMDI), trimethylhexamethymene diisocyanate (TMDI), and their blends. The best results were achieved with a blend of THDI and TIPDI.

As ADEDT is a strictly bi-functional substance, curing it with a bi-functional diisocyanate produces a linear, not crosslinked polymer, which cannot be expected to have an excellent gas impermeability. Therefore, we have tried to use more high-functional isocyanates. Curing the resin with a straight tri-functional trimer of diisocyanate is difficult: first of all, only one such substance is liquid (THDI), and introducing a solid curing agent (for example, TIPDI) necessitates the presence of some solvents, which, usually, spoil the impermeability properties of polymers or are undesirable as VOC. However, we have found a way to bypass this difficulty by dissolving the solid TIPDI in a liquid THDI.

The results of CEES vapor permeability testing of several formulations are shown at Figure 7. Among other results, it demonstrates the increase of the duration of full protection by 9-12 mil films from 7 hours (ADEDT cured with THDI, 10 mils) to 24.5 hours (ADEDT cured with THDI/TIPDI 70:30 blend, 13 mils) and 27.5 hours (ADEDT cured with IPDI/ TIPDI 50:50 blend, 12.5 mils).

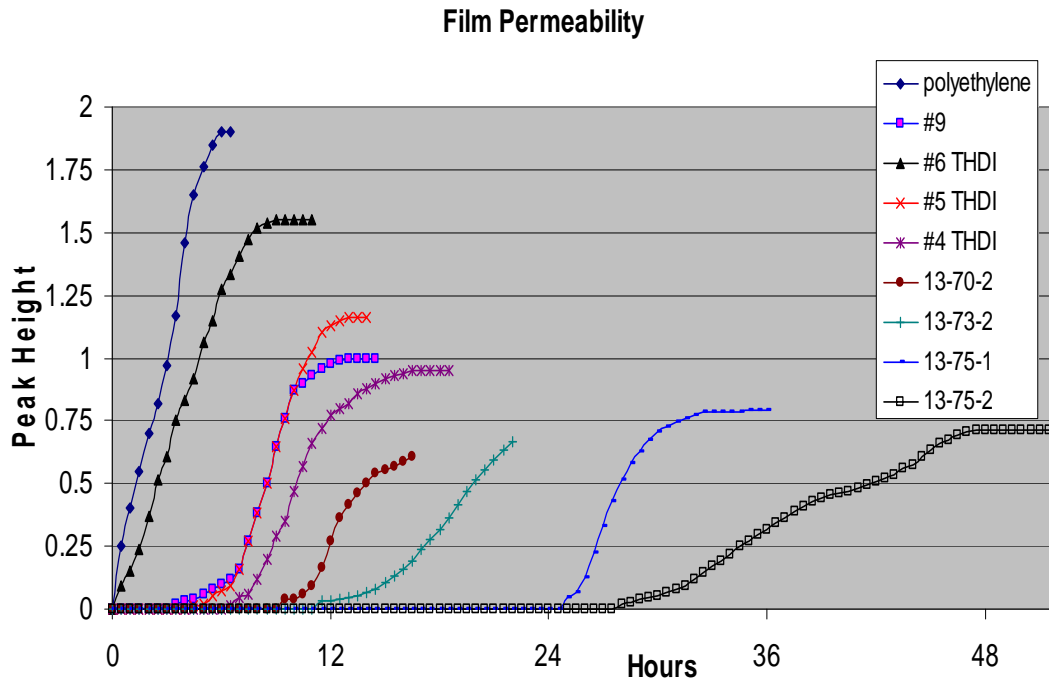

Fig. 7. CEES Vapor Permeability Testing of Different Formulations (~10 mils Films)

Table 1 shows some of the results of the testing of 10-13 mil films produced from ADEDT and different curing agents.

Table 1. Complete Protection for ADEDT Cured with Different Curing Systems

Curing Agent	Complete Protection Duration (Hours)
THDI	7
THDI/TIPDI 70:30	24.5
THDI/TIPDI 60:40	24 (resin too viscous)
IPDI/TIPDI 50:50	27.5 (resin too viscous, film too brittle)
IPDI/TIPDI 60:40	24 (film too weak)

POLYMERright had selected ADEDT (resin side) and 70:30 blend of THDI and TIPDI (curing agent/hardener side) for further formulating efforts.

4.2.2 Step 2. Formulating Additional Reactive Components on the Resin Side

The general chemical considerations and our experience in polymer chemistry allowed us to predict that an addition of another sulfur-containing lower molecular weight reactive component to the resin part could improve the impermeability of the formulation.

Curing of such resin blends results in the production of polyurethanes with a segmented structure. Such structure is much denser, and it has fewer voids that lead to easier penetration of CAs through a polymer.

We have chosen DiHydroxyEthyl-TriSulfide (DiHETS) as a segmentation-causing component of the resin system. DiHETS has the structure (6).



Experimental work demonstrated that the presence of up to 30 mass parts of DiHETS (1:1 ADEDT/DiHETS molar ratio) either does not affect the duration of complete protection of films against CEES vapors, or even slightly increases it.

The ability to add to ADETS a compound with lower molecular weight provided us with additional flexibility in the creation of coatings with convenient resin/hardener ratios.

4.2.3 STEP 3. Formulating Plasticizers

POLYMERright has tested several classes of plasticizers (aliphatic monoesters, phthalate diesters, chlorinated paraffins, and functionalized vegetable oils) as components of future coatings. Unfortunately, it was proved that all the tested plasticizers significantly shorten the protection, and thus are not recommended for future use in protective coating formulations.

4.2.4 STEP 4. Formulating Fire Retardants

From the inception of the project we have planned to produce coatings that are fire-retarded, i.e. coatings that do not keep burning after the ignition source is removed. We

had hoped that it will be true for the films produced from straight polysulfide resins. Unfortunately, experimental work has proven that these hopes were groundless. This necessitated formulating work towards the goal of fire-retarding the targeted coatings.

There are two types of commercial fire retardants: liquid and solid. Liquid fire retardants are used less broadly than the solid ones, and there is relatively few of them available commercially. Only liquid fire retardants can be used to formulate a transparent coating. POLYMERright has tried two main types of liquid fire retardants: brominated material-based and phosphorus-based, and proved that it is impossible to produce a transparent fire-retardant coating with the fire retardants that are commercially available now. All the tried liquid fire retardants severely degrade the protection level of produced films. Thus it proved to be impossible to produce fire retarded transparent coatings.

However, POLYMERright can produce transparent not fire retarded protective coatings, and such products proved to be useful later, when POLYMERright's coating was tested for the HaMMER program.

The use of solid fire retardants leads to the coating being non-transparent. In the course of work, we have found out that the addition of most solid fillers (including solid fire retardants) diminishes the protective capacity of polysulfide-based films.

However, we have identified a combination of brominated and antimony-based fire retardants that minimizes this negative effect, while providing maximum fire retardation. We have established that our fire-retarded formulated 35 mil thick film provides 100% protection against CEES vapors for 85 hours.

4.2.5 STEP 5. Formulating Catalysts

POLYMERright has evaluated several catalytic systems and accelerators as components of the future formulations. We have identified the most promising classes of these products and proved that the most effective is a combination of a tertiary amine with a metal-organic catalyst. Most tertiary amine catalysts are corrosive and have an unpleasant odor, but we had managed to bypass these problems by using, instead of a straight tertiary amine, an odorless amine-treated rheology modifier.

The formulating work with catalysts and accelerators allowed us to create a family of formulations with dry-to-touch times that vary from 15-20 min to 1-1.5 hours that all have similar protective properties. The choice of the formulation with a proper curing rate will depend on the chosen application technique and the requirements of each particular job.

4.2.6 STEP 6. Application Technique and Development of Protective Properties Kinetics

POLYMERright has established that for all the coating formulations protective properties are developing gradually in the course of curing (see Fig. 5), and that the time of

complete protection immediately after a coating is dry to touch is significantly lower than several days after application. It must be noted that the development of protective properties occurs much faster in the rapidly-curing, strongly catalyzed formulations.

This development has led us to a conclusion that the hand-applied brushable and rollable formulations with a long pot life that allows to use these application techniques will be less than useful for rapid conversion of existing structures in chem-bio shelters in forward locations. Such formulations cure slowly, and do not seem to accumulate significant protective properties in reasonable time, which is clearly unsuitable for the scenario that requires the coatings targeted by this project.

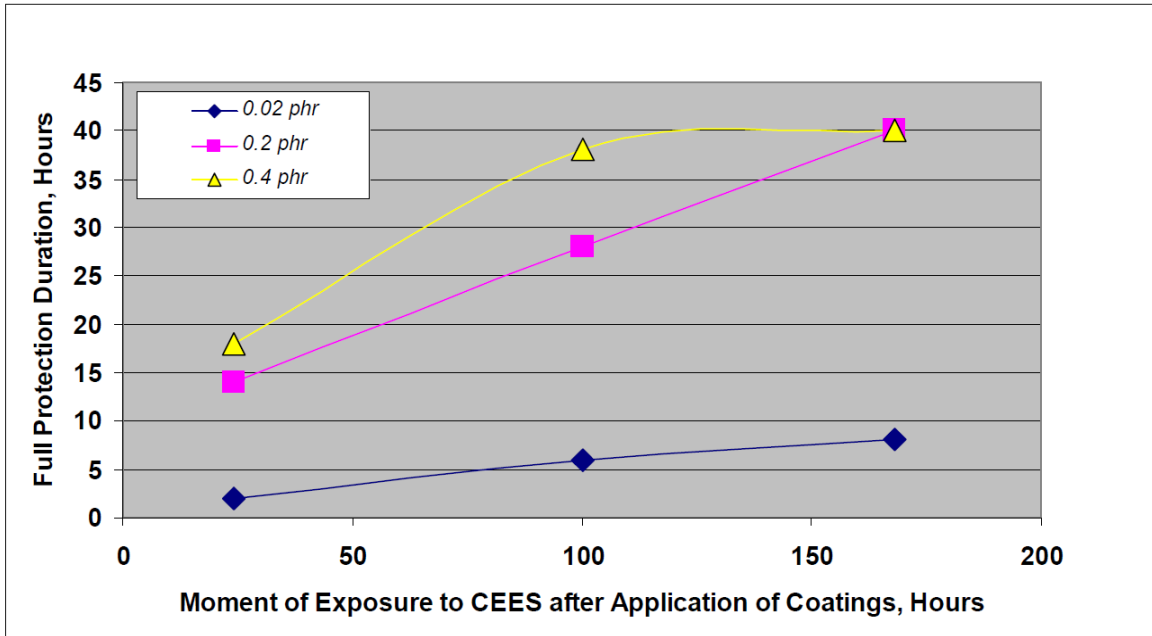

Fig. 5. Duration of Complete Protection as a Function of an Interval between the Coating's Application and Its Exposure to CEES Vapors for Coatings with Different Concentrations of Catalytic System

Therefore, POLYMERright has concentrated on the spray-applied, rapidly curable formulations that accumulate protective properties much faster. POLYMERright has acquired a dual component air-assisted cartridge spray system, and a plural components airless spraying system. These systems were used at the later stages of the project to apply the coating formulations on large testing objects.

4.2.7 Phase 2 Conclusions

- On the resin side, the created family of coatings contain ADEDT (hydroxy-terminated ester of adipic acid and dihydroxyethyl trisulfide) with addition of 0-30 mass parts of DiHETS (dihydroxyethyl trisulfide);
- On the hardener side, the created family of coatings contain a mixture of THDI and TIPDI (trimers of hexamethylene diisocyanate and isophorone diisocyanate);
- The formulation cannot contain any plasticizers;

- The formulation must be strongly catalyzed with a mixture of amine-based and organo-metallic-based catalysts;
- Fire retardancy can be achieved by a mixture of brominated and antimony-based solid fire retardants; and
- The formulation cannot be applied by brushing/rolling. The only acceptable application technique is spraying with various plural component sprayers.

All the products with ADEDT with or without DiHETS on the resin side and THDI with TIPDI on the hardener side were designated as ThioShield™ family of coatings.

4.3 Phase 3. Evaluation of the Properties of Films

In the course of the project POLYMERright has evaluated different properties of the cured ThioShield™ films.

It must be noted that in the course of this stage of the project DTRA has requested POLYMERright to conduct the following research taking into account not only the straight task of converting existing structures into COLPRO shelters. We were asked to look at the targeted coating as an integral component of the broad hazard mitigation strategy, where it could limit the penetration of contaminants onto any underlying substrate and reduce the residual CA hazard that remains on substrates after the removal of the coating. Thus the function of the coating would not only isolate the internal volume of a structure from external CA attack and reduce the load on the air cleaning filters. The created coating should also significantly ease decontamination and hazard mitigation operations for any objects that were exposed to CA agents prior and/or after the application of the coating.

The key response parameter chosen to evaluate the effectiveness of protection provided by the coating was the duration of complete protection of the coating film against the penetration of the CA simulants in vapor and liquid phase.

4.3.1 Duration of Protection vs. Film Thickness

POLYMERright has evaluated the duration of protection vs. thickness of the film for three ThioShield™ systems:

- Straight ADEDT, cured with THDI/TIPDI 70:30,
- Segmented ADEDT/DiHETS 1:1, cured with THDI/TIPDI 70:30, and
- Segmented ADEDT/DiHETS 1:1, cured with THDI/TIPDI 70:30, with addition of the fire retarding fillers

The results of this evaluation are shown in Figure 6.

These experiments demonstrated robustness of the level of protective properties for each ThioShield™ formulation and that it is possible to obtain a clear mathematical function allowing to predict the duration of protection for films with different thickness and to compare different systems with non-matching thickness of films.

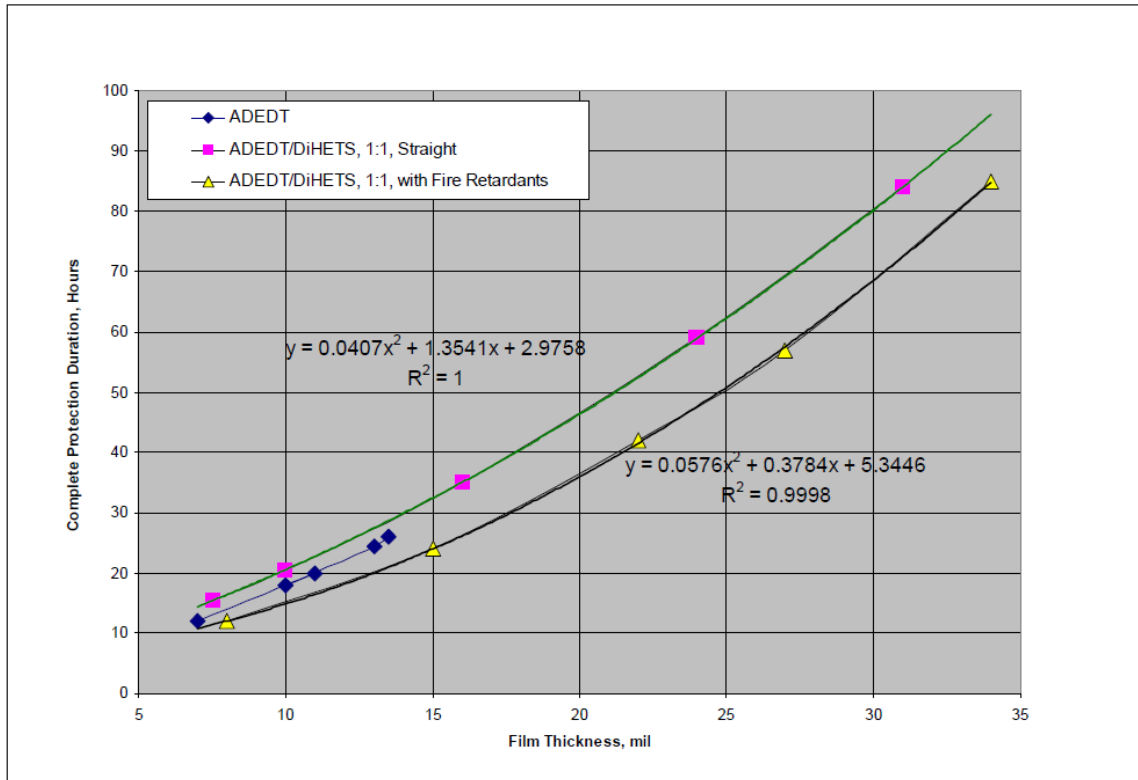

Fig. 6. Duration of protection vs. thickness of films for different formulations

4.3.2 Duration of Protection vs. Time after Application

We have established that for all the ThioShield™ coating formulations protective properties are developed gradually in the course of curing (see Fig. 5), and that the time of complete protection immediately after a coating is dry to touch is significantly lower that several days after application.

4.3.3 Thermal Stability and Low Temperature Properties

POLYMERright has conducted an analysis of thermal stability and low temperature properties of ThioShield™ films using Differential Scanning Calorimetry by an independent lab (Chevron Phillips Chemical LP). We have established that the produced polymeric films are thermally stable at least up to +150°C, and have glass transition temperature (Tg) below -50°C, and thus can be used as coatings at the low temperature locations.

4.3.4 Absorptive/CA Sequestration Properties

In the course of work it became evident that the created ThioShield™ films have significant absorptive properties towards the tested CA imitants. The films noticeably

swelled after the tests (see Figure 6), and their weight, at the moment of breakthrough, was increased by 10-12%. Again, it is worth noting that the tests were conducted under the overwhelmingly high loads of simulants: over 250 g/m².

As it was mentioned above, Michael Henley's group at Tyndall AFB has independently verified POLYMERRight's results under a standard 10 g/m² load of CEES. Unfortunately, this test did not allow quantifying the results as all CEES was absorbed into the film that was being tested without any breakthrough. The test had to be terminated after 1 week without any indication of penetration of CEES through the film.

Later, these properties of the targeted coatings were confirmed by Battelle Memorial Institute in the course of testing the ThioShield™ films with live HD agent.

4.3.5 Duration of Protection against Liquid CEES and Other Compounds

POLYMERRight has evaluated protective properties of the ThioShield™ coating not only against CEES in vapor phase. We have also conducted similar test with

- CEES in liquid phase,
- Another HD simulant, dichloroethyl ether, in both vapor and liquid phase,
- Diethylmethyl phosphonate (GD and GB simulant) in liquid phase, and
- Demeton (VX simulant) in liquid phase.

Also, under a subcontract with POLYMERRight, Battelle Memorial Institute has evaluated the ThioShield™ films for the action of live HD agent in both vapor and liquid phases. The results of this evaluation are described below.

In the POLYMERRight's tests, the evaluations were conducted under the same extremely high chemical load of 250 g/m² on films with realistic thickness (60 mils, or 1.5 mm). The results of POLYMERRight's tests are shown in Figure 7.

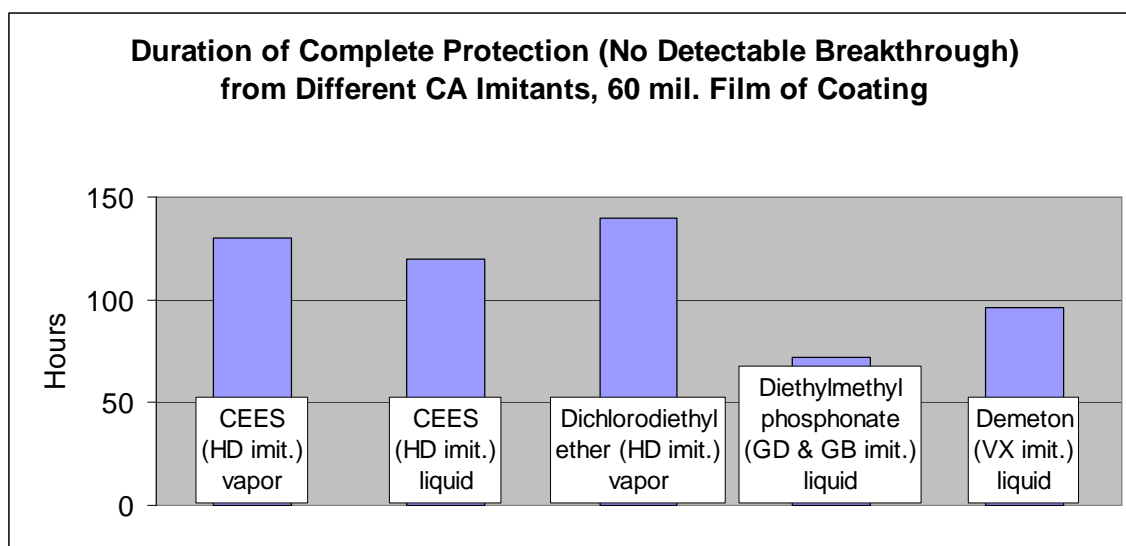

Fig. 7. Duration of Protection against Liquid CEES and Other CA Simulants

4.3.6 Phase 3 Conclusions

- The protective properties of the coating are highly dependent of the applied coating thickness.
- It is possible to obtain a clear mathematical formula allowing to predict the duration of protection for films with different thickness and to compare different systems with non-matching thickness of films.
- Protective properties in all the ThioShield™ coating formulations are developed gradually in the course of curing: the time of complete protection immediately after a coating is dry to touch is significantly lower that several days after application.
 - Thus, if possible, in order to achieve maximum protective properties, it is recommended that the coatings are allowed to cure for 2-3 days prior to the potential exposure to CA contamination.
 - If the preliminary application of the ThioShield™ coating is not possible, in order to provide sufficient protection, the coating must be applied with increased thickness.
 - In view of the shifted focus of the development, additional efforts are needed to quantify protection properties of the ThioShield™ coating when it is applied atop of the CA agents or their simulants deposited on various substrates.
- It was experimentally proven that, in the cases when CA agents and/or their simulants are applied atop of the cured ThioShield™ coating, the coating has significant sequestration properties.
- Additional work is needed to better quantify these properties and to evaluate them in situations when the coating is applied on the already contaminated substrates.
- The sufficiently thick (60 mils) ThioShield™ coating layer provides durable (over 70 hours) protection against penetration of all the tested CA simulants in liquid and vapor forms, even when they are supplied in unrealistically-high load (250 g/m²).

4.4 Phase 4. Evaluation of the Air Retention Properties of ThioShield™ Coating

The work on this Phase of the project was conducted simultaneously with the Phase 3. At this project phase we had conducted several steps.

4.4.1 Step 1. Creation of a Technique to Apply the Coating to Large Surfaces

At this step of the Phase 4 POLYMERright has developed a technique to apply ThioShield™ coating to large surfaces. POLYMERright has acquired a dual component air-assisted cartridge spray system, and a plural components airless spraying system.

The first tests of the air-assisted spraying system revealed that this application technique, though suitable for coating of small surfaces, is not the best choice when it is necessary to cover large surfaces: it required multiple recharges of cartridges, and noticeable amount of material had to be discarded together with the static mixers and spraying heads. The

coating solidified inside of these parts while the emptied cartridges were being exchanged for the full ones.

In order to test the plural component spraying technique, POLYMERright has procured air-driven Constant Flow, Two Part Metering, Super Duty Dispenser System produced by Michaels Engineering. This system was designed to produce accurately metered constant flow adjustable from a very slow gentle output, up to 27 lbs. per minute. Typically, this machine is used for dispensing two-part urethanes, epoxies, silicones, and other formulations. The machine allows easily adjusting the ratio of components in 3.5:100 - 1:1 range.

Unfortunately, we discovered that, to properly dispense ThioShield™ coatings, the system required significant modifications. However, after we had spent significant efforts in modifying the system for coatings' application, it proved that applying our coating with a plural component spraying system is an optimal technique for converting existing buildings into COLPRO shelters. The modified Michaels Engineering dispensing system that was used in consequent testing is shown in Figure 8.

4.4.2 Step 2. Construction of the Testing Shed

POLYMERright has built an 8'x6'x8' model shed with typical features of a simple building. The walls and ceiling of the shed were made from drywall on a wooden carcass. The shed had plywood floor, window, and simulated electric outlets. In the course of construction of the shed we had intentionally left several cracks $\frac{1}{8}$ " and $\frac{1}{4}$ " wide.

For the evaluation of the air loss, in the doorframe of the shed we had installed Energy Conservatory Blower door connected with a computer with TECTITE Ver. 3.2 Airtightness Test Analysis Software. The shed is shown on Figure 9.



Fig. 8. Modified Michaels Engineering Spraying System



Fig. 9. Testing Shed with Energy Conservatory Blower Door

4.4.3 Step 3. Evaluating the Air Loss of the Testing Shed

Initially, we had evaluated the air loss from the shed “as constructed”, i.e. with unpatched cracks. Then we had patched the cracks with duct tape and repeated the air loss evaluation.

After this evaluation, we had removed the duct tape and applied the ThioShield™ coating to the whole inside surface of the shed. It must be noted that, while the $\frac{1}{8}$ ” wide cracks were easily covered with the sprayed coating, covering the $\frac{1}{4}$ ” wide cracks without any patching, while possible, took extremely high amount of the sprayed coating and long time. Therefore, all the consecutive $\frac{1}{4}$ ” wide cracks were, prior to coating application, covered with the drywall joint fiberglass mesh tape. The process of coating is shown in Figure 10.

After the shed was completely coated, we had re-installed the Energy Conservatory Blower door and had evaluated the air loss of the coated structure. The results of the evaluations conducted on the initial, “as constructed” shed, the same shed after it was patched with duct tape, and the same shed after it was coated are shown in Table 2 and Figures 11 and 12.



Fig. 10. Testing Shed in the Process of Coating Application

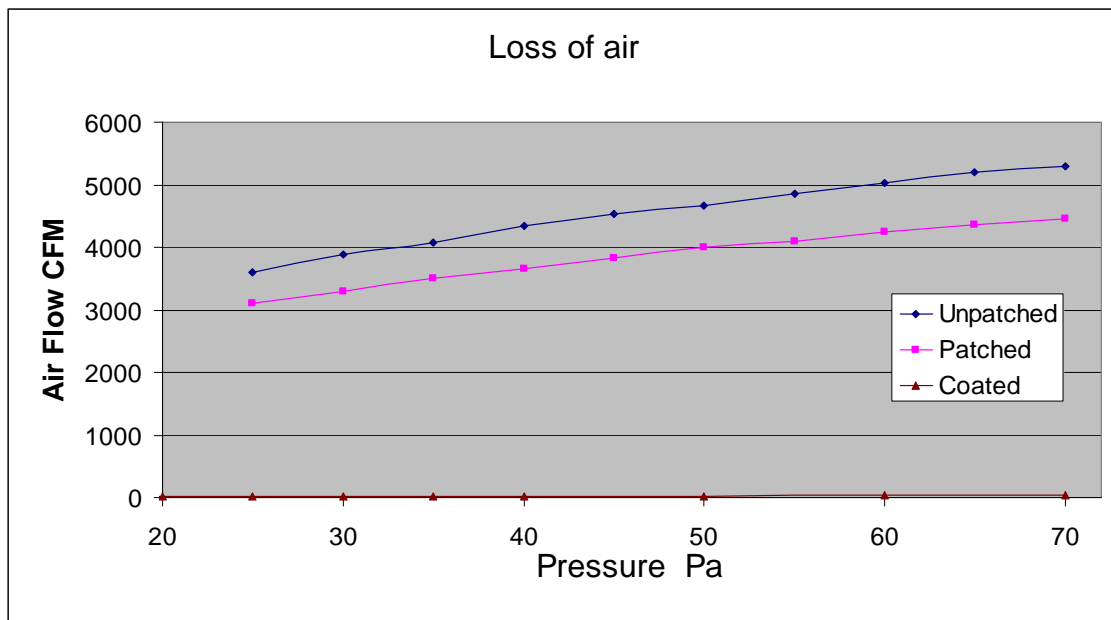

Fig. 11. Air Loss from the Shed, Linear Scale

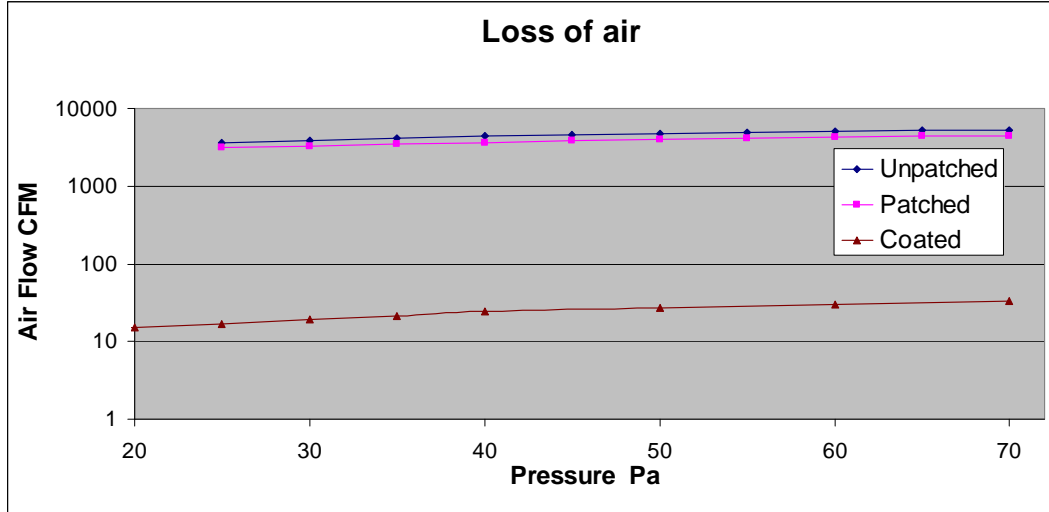

Fig. 12. Air Loss from the Shed, Logarithmic Scale

TABLE 2. Shed Air Loss Testing Results

Pressure PA	Air Loss (Cubic Feet per Minute)		
	Initial	Patched	Coated
15			14
20			15
25	3600	3100	17
30	3880	3300	19
35	4080	3500	21
40	4350	3650	24
45	4530	3825	
50	4674	4000	27
55	4860	4100	
60	5029	4250	30
65	5200	4370	
70	5300	4450	33

4.4.4 Step 4. Evaluating the Removability of the Coating from Different Substrates

Simultaneously with the testing of the shed air loss, POLYMERright has conducted the evaluation of removability of the ThioShield™ coatings from different substrates. The testing revealed that the coating can be easily peeled off from smooth surfaces, such as glass, plastic, bare metal and wood, surfaces covered with glossy paint, etc. and concrete, cinderblock and brick. The removal of the coating from the drywall was also easy, but a thin layer of the surface paper that covers drywall was removed together with the coating.

The removal of ThioShield™ coatings from rough surfaces (unpolished wood, weathered rubber, matted paints, etc.) was more difficult. Though, usually, it was possible to remove this paint, it required significant expenditures of time and effort.

Later, in the course of the Phase 5 of the project (described below) POLYMERright has discovered a way to significantly reduce adhesion of the ThioShield™ coatings to rough substrates, making them easily peelable from practically any surface.

4.4.5 Phase 4 Conclusions

From the conducted evaluation, it is possible to make the following conclusions:

1. The cartridge-based air-assisted spraying systems are suitable only for coating of small ($< 1 \text{ m}^2$) areas.
2. The plural component spraying systems are needed for the protection of structures, constructions or mechanisms large surface areas.
3. Patching of the visible cracks with duct tape in a very ineffective way to diminish the air loss from a building;
4. It is beneficial, prior to applying the ThioShield™ coating inside an existing structure, to cover cracks that are wider than $\frac{1}{8}$ " by some supporting material, like, for example, drywall joint fiberglass mesh tape; and
5. Applying the developed coating to the inside of an existing structure allows cutting the air losses by more than two orders of magnitude, converting such structure into a base of a highly effective chemical/biological shelter.

4.5 Phase 5. Work Targeting Hammer Program

In the course of work on the project we had unexpectedly received a request from DTRA to try and adjust our coating for the needs of the HaMMER program.

4.5.1 Phase 5 Description

We had received a Hammer tailgate that was painted with CARC coating, and had applied Thioshield™ 1394-1 FR (Fire Retarded) coating atop of the CARC. Unfortunately, the removability of our coating from this substrate left much to be desired as our coating bonded to the CARC pretty strongly.

POLYMERright jointly with Chevron Phillips Chemicals LP has produced several gallons of the Thioshield™ 1394-1 NFR (Non Fire Retarded) coating for this program. A 5 Gal. sample was sent to Batelle Memorial Institute for testing in the HaMMER program, the rest of the material is used in-house for additional testing. We proved that the natural color of Thioshield 1394-1 NFR (clear) can be adjusted to the HaMMER-targeted colors (brown and dark green) using commercial brown and green pigments with and without Titanium Dioxide base.

POLYMERright has procured CARC-covered aluminum coupons from Automated Coatings. They have were coated with

- Pretreatment: Chemical Film IAW MIL-DTL-5541, Type I, Class 1A
- Primer: MIL-P-53022
- Paint: MIL-DTL-64159, FED-STD-595 Color #34094, 383 Green

These coupons were used for the evaluation of adhesion and peel-off for ThioShield 1394-1 FR and NFR versions, which proved to be satisfactory for the stated contamination scenarios. However, though ThioShield coatings could be easily separated from these coupons, the results were quite different when the same coatings were applied to the old CARC-covered coupons that were acquired several years ago and stored in POLYMERright laboratory. It was practically impossible to peel of the coating from these coupons. We had made a conclusion that CARC ages with time, and its surface properties change. Thus it was still necessary to diminish the bonding strength of ThioShield formulations to this substrate.

We had evaluated four additives (fumed silica, Chlorovax 415W, Benzoflex 9-88 and THEIC) as means to further reduce adhesion of ThioShield coatings to various substrates. Altogether, ten formulations with these additives were created, and their properties were evaluated. Unfortunately, though all of these additives were successful in reducing adhesion, the protective properties of the coating were also significantly reduced. Therefore, it was concluded that these adhesion reducing additives were unsuitable for the purposes of this project.

There is a well-established way to reduce the adhesion of a polymer to the substrates that is broadly used in the liquid resin casting technology. To achieve this purpose, the substrates are treated with mold releases. POLYMERright has acquired eight different aerosol-sprayed commercial release agents and, prior to the application of the ThioShield coating, sprayed them on the CARC-painted coupons. This test had confirmed that pre-treatment with all release agents was an efficient way to further reduce the adhesion of the coating to rough and matted substrates.

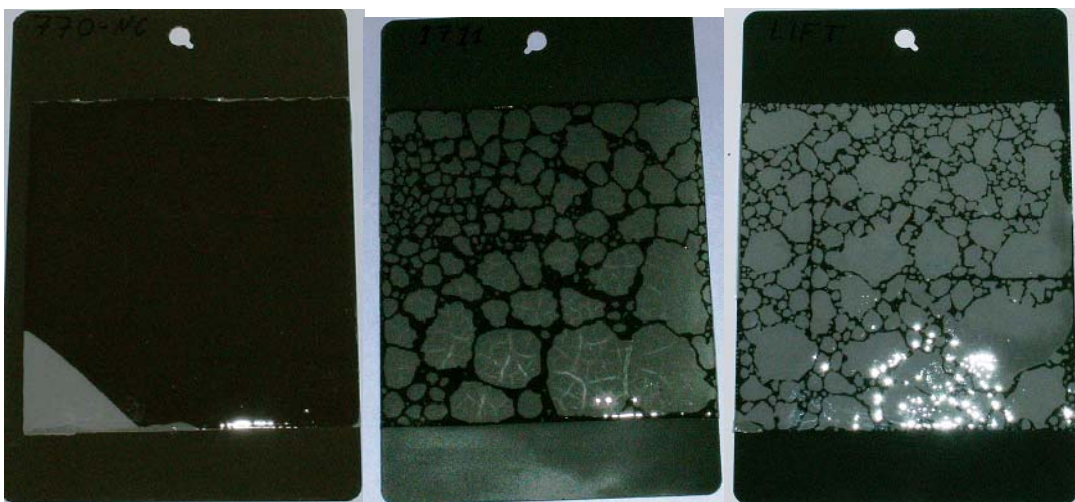

Fig. 13. ThioShield Coating Applied Atop of the Release Agents-Sprayed CARC-Painted Coupons

The tested sprayed mold releases were very effective and allowed peeling off the coatings with only minimal efforts. However, applying the ThioShield coating atop of the tested release agent has resulted in some of the tests in formation of bubbles underneath the coating, which is not desirable. Another negative feature of the tested release agent was that an excessive amount of it caused such a great adhesion drop that the coating could peel of the vertical underlaying structures under its own weight. The results of these tests are shown in Figure 13.

The Stoner E-236 Urethane Mold Release has demonstrated the best results: ThioShield coating could be easily peeled off the CARC paint without formation of any bubbles under the coating.

We had also conducted tests to evaluate the removability of the coating from the other substrates with significant presence in any vehicle, i.e. rubber, glass, polished metal, etc. ThioShield coating proved to be easily removable from the smooth substrates (glass, polished metal, glossy paints and smooth rubber surfaces without any pretreatment. However, the removal of the coating from the automotive tires and rough metal (including nuts, bolt heads, welding joints, etc. could require the same type of pretreatment as the old CARC paint, i.e. light spray of the surface with polyester or PTFE-based aerosol mold releases.

4.5.2 Phase 5 Conclusions

The work conducted in this Phase of the project allowed to make the following conclusions:

- ThioShield coatings can be easily removed from all glossy surfaces without any pretreatment.
- Pre-treating the surfaces with commercial polyester or PTFE-based aerosol mold releases allows easy removal of ThioShield coatings from all rough surfaces.
- Some mold releases can cause an undesirable effect of complete loss of adhesion between the coating and substrate.

4.6 Phase 6. Testing of the Coating with Live HD Agent

POLYMERright has subcontracted Battelle Memorial Institute to conduct this testing. Due to the limited scope of the Battelle's HD testing, as we knew that the duration of every individual test in Battelle cannot exceed 24 hours, we have provided them with thin (~10 mils, or ~0.25 mm) coating films. Such thin films will shorten the duration of each test and allow Battelle to reach the breakthrough point of HD, thus quantifying the protective properties of the coating.

The detailed Battelle's report is in Appendix 1.

4.6.1 Phase 6 Conclusions

Battelle's findings are:

- HD vapor permeability testing at 20 mg/m³ HD vapor challenge revealed no detectable breakthrough of HD through ~10 mil film after 24 hours.
- HD liquid permeability testing at 10 g/m² HD liquid challenge revealed no detectable breakthrough of HD through an ~10 mil film after 6 hours. The next sample that had revealed breakthrough was taken after 16 hours. After 24 hours, only 5% of the challenge broke through the film.
- There are strong indications (Figure 2 of the Battelle's report) that "increasing the (film) thickness (such as to 20-30 mil) would potentially prevent breakthrough from occurring under the test conditions".
- The coating has shown significant HD sequestration/reactive properties: after 24 hours of 10 g/m² HD liquid challenge, only 12% of HD could be extracted after 1 hour hexane extraction procedure.

Battelle concluded that "data produced under this effort suggests over a 24 hour time period it can resist HD permeation from a 20 mg/m³ vapor challenge. The coating has also demonstrated it can significantly limit HD breakthrough to approximately 5% of a 10 g/m² challenge over a 24 hour period. As this coating is designed to be applied to structures to provide chemical protection, it is suggestive that the coating would offer protection over the same structure with no coating".

5. OVERALL PROJECT CONCLUSIONS AND RECOMMENDATIONS

In the course of the conducted project POLYMERight has created and tested two members of the impermeable and removable family of coatings. Both these formulations are 100% solid two-parts coatings that do not contain any VOC, HAP, heavy metals or other regulated components:

- ThioShield FR (fire-retarded coating with 1:2 component ratio), and
- ThioShield NFR (not fire-retarded coating with 1:1 component ratio).

Both members of the ThioShield family of coatings are ready for use in multiple CBD-related applications. The commercial-scale production of the developed coatings can proceed on a short notice by Chevron Phillips Chemical LP, a multi-billion specialty chemicals company that has licensed POLYMERight's developments in the polyester polysulfide chemistry.

5.1 Conclusions and Recommendations Re. Collective Protection

POLYMERight's ThioShield coatings have proven to provide an effective solution to the problem of expedient conversion of existing structures (houses, warehouses, sheds, etc.) into chemical and biological shelters.

When applied to a structure 24-48 hours prior to the expected CB attack with a reasonable (30-50 mils) thickness, they

- Completely prevent penetration of the liquid- and vapor-phase CB agents through coated surfaces for practically unlimited time when CA are present in very high amounts ($\sim 10\text{-}20\text{ g/m}^2$) or for at least 5-6 days if CA are present at overwhelming load of over 250 g/m^2 ;
- Diminish the air losses through the structure by more than two orders of magnitude, eliminating excessively high load on the air cleaning and filtration units;
- Allow easy decontamination and return to service of the structure after the CB attack, or if the expected attack did not occur.

The negative feature of the developed coatings is that their application to large surfaces requires rather cumbersome and complicated plural component sprayers. In the case these coatings will be seriously considered for conversion of the existing structures into chemical and biological shelters, we think that some work should be conducted jointly with experienced commercial applicators of coatings with similar physical and properties and rate of curing, such as, for example, polyurea-based coatings. This work should target the identification of the least costly and complicated-to-operate plural components sprayers and development of the application techniques that could be implemented by inexperienced personnel at forward locations.

5.2 Conclusions and Recommendations Re. Hazard Mitigation

In the hazard mitigation area we were asked to consider the use of our coating the following three scenarios:

1. The coating is applied on a vehicle prior to entering contaminated area, and removed immediately after leaving the contaminated area. In this case, after the coating is peeled off and sent for disposal, the vehicle remains clean from any contamination that could be deposited on it while it was moving through the contaminated area.
2. A vehicle moves through a contaminated area and becomes contaminated itself. The coating is applied immediately after leaving the contaminated area atop of the contamination, sealing contaminants and allowing to use the vehicle for some time without decontamination. After some time, the coating is peeled off. The contaminants are removed with the coating, leaving no contaminants (or only traces of contaminants) on the vehicle.
3. The coating is applied on a vehicle prior to entering contaminated area, it moves through a contaminated area and the coating becomes contaminated. Another layer of the coating is applied immediately after leaving the contaminated area atop of the contamination, sealing contaminants between two layers of coating and allowing to use the vehicle for some time without decontamination. After some time, both layers of the coating are peeled off. The contaminants are removed with the coating, leaving the vehicle free from contamination.

It must be noted that the additional focus on hazard mitigation has been identified very late in the project, and POLYMERright had time and resources to evaluate only the first scenario.

This evaluation allowed to conclude that a coating film 30-60 mils thick completely prevent penetration of liquid- and vapor-phase CB agents to the surface of the vehicle for practically unlimited time when CA are present in very high amounts ($\sim 10\text{-}20\text{ g/m}^2$) or for at least 5-6 days if CA are present at overwhelming load of over 250 g/m^2 .

Additional work is needed in order to

- test the behavior of CA agents and/or simulants when the coating is applied atop of the contaminated surface;
- interaction of the contaminants with release agents that allow easy separation of the coating from rough vehicle substrates (old CARC coatings, rough metal parts, rubber, etc.);
- quantify the residual contamination that remains on substrates after the coating with sequesters CA are peeled off.

6. APPENDIX 1

TEST REPORT for POLYMERright, Inc. Coating Agent Testing

**Prepared for:
POLYMERright, Inc.**

**Prepared by:
Edward Soja
Brian Blackstone
Battelle Memorial Institute
505 King Ave.
Columbus, Ohio 43201-2693**

TEST REPORT

for

POLYMERRight, Inc. Coating Agent Testing

Prepared for:

**POLYMERRight, Inc.
Mr. Alex Vainer
4404-C Enterprise Place
Fremont, CA 94538**

Prepared by:

**Edward Soja
Brian Blackstone**

**Battelle
505 King Ave.
Columbus, Ohio 43201-2693**

31 August 2012



Disclaimer

This report is a work prepared for POLYMERright, Inc. and the United States Government by Battelle. In no event shall either POLYMERright, Inc., the United States Government, or Battelle have any responsibility or liability for any consequences of any use, misuse, inability to use, or reliance upon the information contained herein, nor does either warrant or otherwise represent in any way the accuracy, adequacy, efficacy, or applicability of the contents hereof.

Table of Contents

	Page
Acronyms and Abbreviations	iv
1.0 Introduction.....	1
1.1 Background	1
1.2 Objective	1
2.0 Technical Approach	3
2.1 Liquid Challenge/Vapor Permeation Resistance Testing	3
2.1.1 L/V Testing – Preparation	3
2.1.2 L/V Testing – HD Application (Spiking)	5
2.1.3 L/V Testing – Sampling and Analysis.....	6
2.1.4 L/V Testing – Trial Termination.....	7
2.1.5 L/V Testing – Raw Data and Calculations	8
2.2 Vapor Challenge/Vapor Permeation Resistance Testing	9
2.2.1 V/V Testing – Preparation	10
2.2.2 V/V Testing – HD Vapor Generation.....	10
2.2.3 V/V Testing – Sampling and Analysis	12
2.2.4 V/V Testing – Trial Termination	12
2.2.5 V/V Testing – Raw Data and Calculations.....	13
2.3 Coating Reactivity Testing.....	13
2.3.1 Coating Reactivity Testing – Solvent Extraction Interference Analysis.....	14
2.3.2 Coating Reactivity Testing – Preparation.....	14
2.3.3 Coating Reactivity Testing – HD Application (Spiking)	14
2.3.4 Coating Reactivity Testing – Sampling and Analysis.....	15
2.3.5 Coating Reactivity Testing – Trial Termination.....	16
2.3.6 Coating Reactivity Testing – Raw Data and Calculations	17
3.0 Safety	19
4.0 Quality Assurance	20
5.0 Summary and Conclusions	21
5.1 Summary	21
5.1.1 L/V Swatch Testing	21
5.1.2 V/V Swatch Testing	21
5.1.3 Coating Reactivity Testing	21
5.2 Conclusions	22
6.0 References.....	23
7.0 Contacts	24

APPENDIX A: TEST MATRIX..... 1

APPENDIX B: SAMPLE CoC 1

APPENDIX C: L/V PERMEATION DATA 1

APPENDIX D: V/V PERMEATION DATA..... 1

APPENDIX E: MATERIAL REACTIVITY INTERFERENCE VERIFICATION..... 1

APPENDIX F: MATERIAL REACTIVITY DATA..... 1

List of Tables

	Page
<i>Table 1. L/V Test Parameters</i>	3
<i>Table 2. HD Challenge Parameters</i>	6
<i>Table 3. Collection Solvents and Analytical Parameters</i>	7
<i>Table 4. V/V Test Parameters</i>	9
<i>Table 5. Coating Reactivity Test Parameters</i>	13
<i>Table 6. Coating Reactivity Testing Analytical Parameters</i>	16

List of Figures

<i>Figure 1. AVLAG Cell Assembly – Static Flow Configuration</i>	4
<i>Figure 2. HD Application Pattern</i>	5
<i>Figure 3. Swatch Picture at Trial End</i>	7
<i>Figure 4. L/V Permeation Data</i>	8
<i>Figure 5. HMRC Custom CA Vapor Generator</i>	11
<i>Figure 6. HD Vapor Concentration</i>	12
<i>Figure 7. Reactivity Testing – Post-Spike Swatch (Trial Start)</i>	15
<i>Figure 8. Reactivity Testing – Post-Weathering Swatch (Trial End)</i>	16
<i>Figure 9. Reactivity Testing – HD Extraction Recovery</i>	17

Acronyms and Abbreviations

Acronym or Abbreviation	Definition
AVLAG	Aerosol, Vapor, and Liquid Assessment Group
CA	chemical agent
CAS	Chemical Abstracts Service
CEES	half-mustard, 2-chloroethyl ethyl sulfide, CAS # 693-07-2
CHCl ₃	chloroform, CAS # 67-66-3
CO	critical orifice
CoC	chain-of-custody
EGDA	ethylene glycol diacetate, CAS# 111-55-7
GC	gas chromatograph
GC/FID	gas chromatograph equipped with a flame ionization detector
GC/FPD	gas chromatograph equipped with a flame photometric detector
GC/MS	gas chromatograph equipped with a mass spectrometer
HD	chemical agent distilled sulfur mustard, CAS # 505-60-2
HMRC	Hazardous Materials Research Center
iwg	inches of water gauge
L/V	liquid challenge/vapor permeation
lpm	liters per minute
LRB	Laboratory Record Book
MDL	method detection limit
MFC	mass flow controller
MSDS	Material Safety Data Sheet
QA	quality assurance
QC	quality control
RH	relative humidity
RSD	relative standard deviation
SBIR	Small Business Innovation Research
SICN	sample identification control number
SOP	Standard Operating Procedure
SST	solid sorbent tube
TICC	Test Item Control Center
TOP	Test Operating Procedure
US	United States
V/V	vapor challenge/vapor permeation
ΔP	pressure differential

1.0 Introduction

1.1 Background

POLYMERright, Inc. has developed and patented a new class of hydroxyl-terminated polysulfide polyesters in support of Phases I, II, and III of the Broad Agency Announcement, W911NF-05-R-0003 for the Army Research Office. Designed to be applied to structures, this novel coating has demonstrated an ability to provide protection against chemical agent (CA) simulants, specifically 2-chloroethyl ethyl sulfide (half-mustard or CEES, Chemical Abstract Services [CAS] # 693-07-2).

Continuing to characterize the performance of this novel coating, POLYMERright, Inc. desired to perform CA liquid challenge/vapor permeation (L/V) and vapor challenge/vapor permeation (V/V) resistance testing on swatches produced from the novel coating to evaluate its performance against distilled mustard (HD, CAS # 505-60-2) over a 24-hour period. Additionally, coating reactivity testing was conducted to examine the fate of HD once applied to the novel coating.

1.2 Objective

Battelle's Hazardous Materials Research Center (HMRC) conducted L/V and V/V permeation resistance swatch testing in accordance with methods established in US Army Test Operating Procedure (TOP) 8-2-501 (dated 17 January 2002 with revisions on 29 April 2003) (1) with modifications as described within this test plan. Coating reactivity testing was executed following existing test methods developed at the HMRC with guidance from the Chemical Decontaminant Performance Evaluation Testing Source Document (2).

Initially, L/V permeation resistance testing was performed following methods developed by the Aerosol, Vapor, and Liquid Assessment Group (AVLAG) for impermeable materials as detailed in TOP 8-2-501. A single trial consisting of 28 coating material swatches was conducted. The trial length was 24 hours with sampling intervals of 0 to 6, 6 to 16, and 16 to 24 hours. Testing was conducted at laboratory ambient conditions. Refer to Section 2.0 for details.

After completion of L/V testing, coating reactivity testing was conducted in order to determine if any degradation was observed or if the coating displayed any resistance to HD absorption. Ten (10) coating material swatches were challenged with neat HD and allowed to weather for 24 hours, after which each swatch was extracted in hexane (CAS # 110-54-3). The hexane extract was analyzed for any remaining HD and/or degradation by-products via gas chromatography equipped with a mass spectrometer (GC/MS). Refer to Section 2.3 for details.

Finally, V/V permeation resistance testing was conducted. A single 24-hour V/V trial including 14 coating material swatches was executed (refer to Section 2.2 for details). A complete test matrix is located in Appendix A of this report.

2.0 Technical Approach

2.1 Liquid Challenge/Vapor Permeation Resistance Testing

Chemical agent resistance testing was performed on material coating swatches following procedures detailed in TOP 8-2-501. The swatches were challenged with neat, liquid HD while CA vapor permeation was sampled beneath the swatch. The contamination density was 10 g/m². The trial length was 24 hours with sampling intervals of 0 to 6, 6 to 16, and 16 to 24 hours. Testing was conducted at laboratory ambient environmental conditions (i.e., temperature = 69°F and relative humidity [RH] = 54%). Swatches were tested using the static flow test methodology in which air flows across the bottom of the swatch at a constant 0.3 liters per minute (lpm). HD was applied to the top of the swatch and sealed so that the challenge remained persistent for the duration of the trial. Refer to Table 1 for L/V test parameters.

Table 1. L/V Test Parameters

Parameter	Description
Flow method	Static flow configuration
Pressure differential (ΔP)	Not monitored
Airflow	0.30 \pm 0.03 lpm
Temperature	Laboratory ambient (69°F)
Relative humidity	Laboratory ambient (54%)
Length of test	24 hours
Sampling intervals	0-6, 6-16, 16-24 hours

Effluent samples were collected beneath the swatch using glass impingers, also termed bubblers. Each was filled with 10 mL of ethylene glycol diacetate (EGDA, CAS # 111-55-7). After each interval, bubblers were removed from the test cell and aliquots taken. Samples were then analyzed by a gas chromatograph fitted with a flame photometric detector (GC/FPD). Additionally, butyl rubber positive and negative control swatches were included in the test. The negative control was a swatch that was not challenged with HD to enable the detection of any system contamination or determine if any analytical interference existed. The positive control was a swatch challenged with HD in the same manner as the material swatches that permeate in a predictable manner. These controls aided in the detection of gross system errors or trial anomalies. Thirty (30) total swatches were tested. Further details are provided in Sections 2.1.1 through 2.1.5.

2.1.1 L/V Testing – Preparation

Material samples were received by the HMRC Test Item Control Center (TICC) for processing. Circular swatches, 2 inches in diameter were cut from coating samples for mounting into the AVLAG test cells (test cells). Each swatch was assigned a unique sample identification control

number (SICN) that was used as an identifier throughout the test. Thickness measurements were also taken for each swatch. Swatches were then assembled into trial packages as presented in the trial chain-of-custody (CoC) that describes the relevant test parameters and lists the swatch SICNs and individual permeation sample (bubbler) SICNs. The CoC remained with the swatches throughout the course of the trial (refer to Appendix B for a sample CoC). An additional copy of the CoC was placed in a laboratory record book (LRB) in which notes and observations were documented.

After the trial package was assembled, the package was released to laboratory operators for trial preparation, where a review was completed to ensure all samples correctly matched the CoC. Swatches were then mounted into the test cells and a label affixed to the cell matching the SICN. Figure 1 illustrates the test cell swatch loading configuration of a 2-inch swatch for static flow testing.

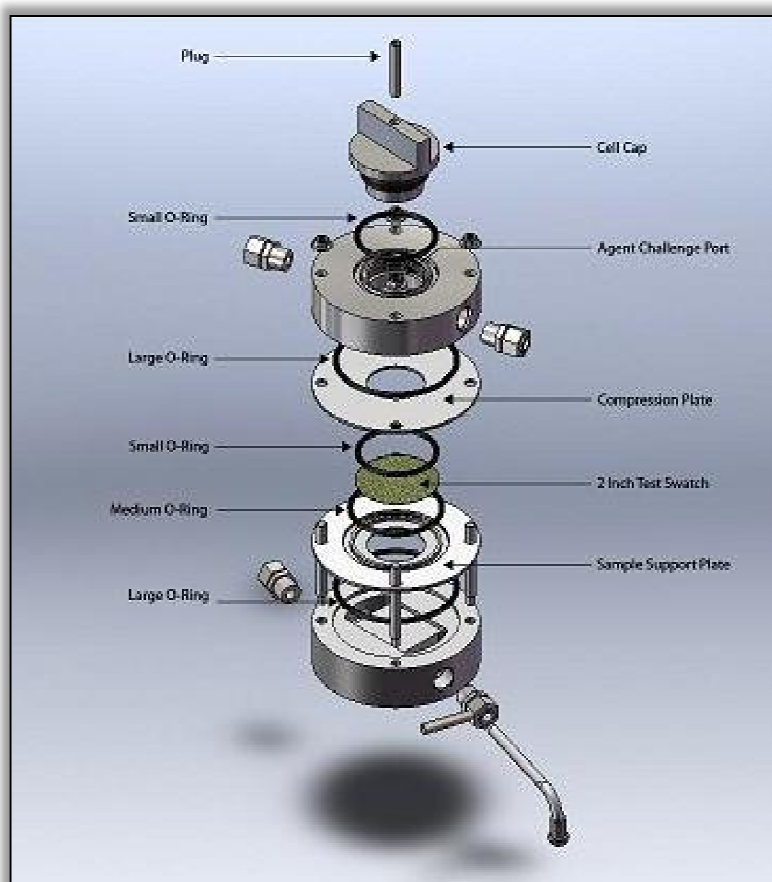

Figure 1. AVLAG Cell Assembly – Static Flow Configuration

Loaded test cells were then seal-checked before HD application to ensure that no air was able to pass around the swatch from top to bottom, as this anomaly could produce a false agent permeation result during testing. To conduct the seal check, a water-filled manometer was

attached to one of the bottom test cell ports and a vacuum attached to the other port. A negative pressure of approximately 2 inches of water gauge (iwg) was created in the bottom of the test cell. A test cell was considered sealed if no pressure drop was observed after 10 seconds. The check occurred with the top cap of the test cell removed. All test cells passed this check.

2.1.2 L/V Testing – HD Application (Spiking)

HD was applied manually using a Hamilton 50- μ L, gas-tight syringe equipped with a repeating dispenser, also referred to as a stepper, which was capable of delivering discrete 1- μ L droplets. The target challenge density was achieved by applying eight 1- μ L droplets following the pattern displayed in Figure 2.



Figure 2. HD Application Pattern

Each swatch had a total of 10 mg of neat HD applied. The challenge density was verified during the spiking process by the use of spike controls. A total of three spike controls were performed and involved the application of HD droplets to a 10 cm² Teflon[®] disc. Each disc was placed in 50 mL of chloroform (CHCl₃, CAS # 67-66-3) for extraction of the HD from the disc. Samples from each chloroform replicate were analyzed via GC equipped with a flame ionization detector (GC/FID) to quantify the HD. A five-point calibration curve bracketing the target concentration of the HD was obtained on the GC prior to analysis. The maximum tolerance was $\pm 20\%$ of the target challenge density. The agent application density met this criteria with an average challenge of 9.5 g/m². HD used in this testing was verified to be 96.2% pure. Refer to Table 2 for HD challenge details.

Table 2. HD Challenge Parameters

Parameter	Description
Challenged exposure area	10 cm ²
HD spiking method	Manual application using a 50- μ L gas-tight syringe with stepper
HD challenge	8 x 1 μ L drop per swatch (1.27 mg/ μ L x 8 μ L = 10.2 \pm 2.0 mg over a 10 cm ² area)
HD purity	96.2%

As each test cell was spiked, it was sealed immediately and passed to an operator for installation into the test fixture. Air lines connected to a separate, clean air supply manifold were attached to each test cell. A bubbler was connected on the effluent side of the test cell in-line with a vacuum pump and mass flow controller (MFC) to control flow at 0.30 lpm. Once all test cells were installed, the vacuum pump was turned on and airflow initiated beneath the swatch; this step marked the start of the trial. The trial was conducted at laboratory ambient temperature and relative humidity as displayed in Table 1. These conditions were monitored but not controlled during the 24-hour trial length. All instruments were calibrated in accordance with HMRC Standard Operating Procedures (SOPs).

2.1.3 L/V Testing – Sampling and Analysis

Bubblers attached to each position were filled with EGDA (CAS # 111-55-7) for collection of any HD vapor that permeated the swatch. The bubblers were continuously sampled over the course of the trial. Changes occurred at 6, 16, and 24 hours, where each bubbler was removed and replaced with a new one. The vacuum pump was not shut off during this sample replacement. Following each sampling interval, aliquots were taken from each bubbler and analyzed by GC/FPD to quantify the amount of HD present.

In accordance with HMRC SOPs, a five-point calibration curve bracketing the target HD concentration was obtained on the GC prior to analysis. During analysis, quality control (QC) checks were performed. For every fifth sample, a standard was analyzed to verify that the calibration had not drifted and every tenth sample was analyzed twice ensuring instrument precision was maintained; all QC checks passed this testing. The method detection limit (MDL) for this test was 0.50 μ g/cm². Refer to Table 3 for solvents and GC calibration parameters used for this test.

Table 3. Collection Solvents and Analytical Parameters

Parameter	Description
HD bubblers	10 mL EGDA
Spike controls	50 mL of CHCl ₃
GC/FPD calibration range	0.5 to 15 µg/mL
GC/FID calibration range	25 to 250 µg/mL
r ² value for calibration curve	≥99%
Frequency of QC checks	Duplicate sample analyzed every tenth sample (must be within 20%)
	Standard analyzed after every fifth sample (lowest standard must be within 25%; all others within 15%)

Samples whose HD concentrations exceeded the calibration range of the GC were diluted into the range at which the instrument was calibrated and re-analyzed.

2.1.4 L/V Testing – Trial Termination

At the completion of the 24-hour trial, bubblers were removed from the test cell. Test cells were then removed from the test fixture and disassembled. Each swatch was visually inspected prior to disposal. One observation of note was that the material deformed slightly where liquid droplets were applied. Refer to Figure 3 for an example picture at trial end.



Figure 3. Swatch Picture at Trial End

No swatches were saved or stored after testing.

2.1.5 L/V Testing – Raw Data and Calculations

GC analysis of each sample from each test swatch at each sampling interval was used to measure the mass of HD per sample ($\mu\text{g/mL}$). From the GC analysis results, the permeated mass per unit area of the swatch ($\mu\text{g/cm}^2$), C , was calculated as presented in Equation 1:

$$C = \frac{GC * V}{A}$$

Equation 1. Mass Permeation per Unit Area

Where:

- GC = measured GC result ($\mu\text{g/mL}$)
- V = sample (bubbler) volume (10 mL)
- A = area of the swatch (10 cm^2)

In summary, all samples demonstrated measurable 0- to 24-hour cumulative permeation. No statistical analysis was conducted, but the magnitude of permeation appeared to be dependent on material thickness. Refer to Figure 4 for cumulative permeation plotted against thickness. Refer to Figure 4 for a plot of permeation breakthrough over time.

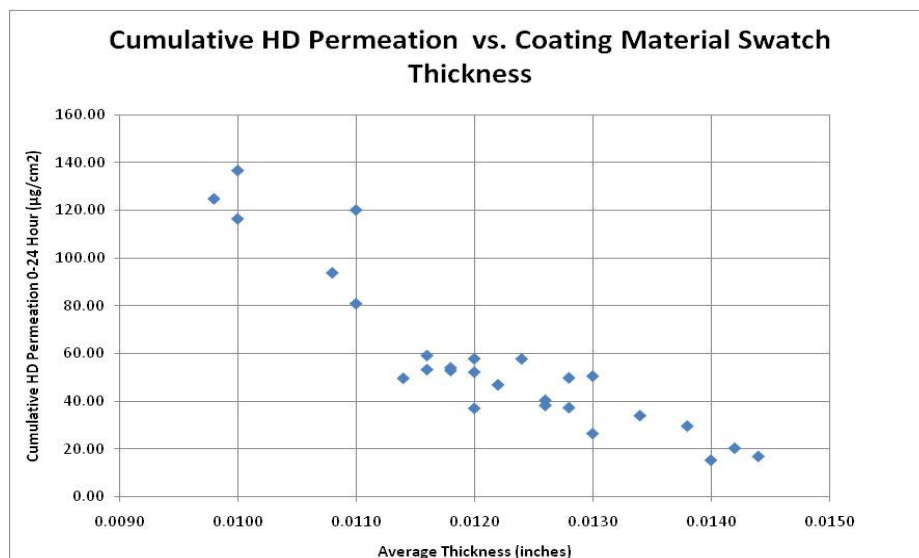

Figure 4. L/V Permeation Data

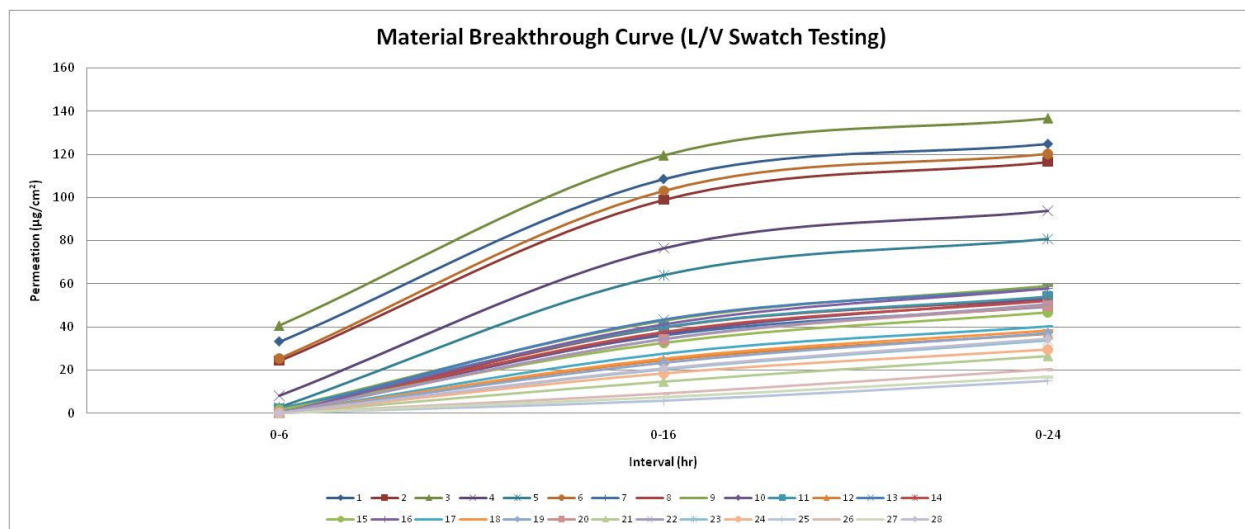

Figure 5. L/V Permeation Breakthrough Curve

Values below the MDL were assigned a value of 0 µg/cm². Cumulative values were obtained by summing each interval. Results obtained for the positive and negative controls were within specification indicating no gross system errors or trial anomalies were present. The complete data set is located in Appendix C.

2.2 Vapor Challenge/Vapor Permeation Resistance Testing

As a result of measurable cumulative permeation values obtained during L/V testing, V/V testing was conducted. Test procedures detailed in TOP 8-2-501 were used as the basis for V/V testing. Swatches were exposed to a vapor challenge of HD above and sampled beneath for HD vapor permeation. The HD vapor challenge target was 20 mg/m³. The trial was conducted over a 24-hour period with sampling intervals from 0 to 6, 6 to 16, and 16 to 24 hours. Testing was conducted at laboratory ambient conditions. Swatches were tested following dual flow test methodology in which clean air was swept beneath the swatch at 0.3 lpm and HD contaminated air was swept across the top of the swatch at 0.1 lpm, applying the challenge over the course of the trial. Refer to Table 4 for V/V test parameters.

Table 4. V/V Test Parameters

Parameter	Description
Pre-conditioning	Not necessary
Flow method	Dual flow configuration
Pressure differential (ΔP)	Not monitored
Airflow	Bottom: 0.30 ± 0.03 lpm Top: 0.10 ± 0.01 lpm
Temperature	Laboratory ambient (69°F)
Relative humidity	Laboratory ambient (54%)

Length of test	24 hours
Sampling intervals	0-6, 6-16, 16-24 hours
HD vapor concentration	$20 \pm 4 \text{ mg/m}^3$

Effluent samples were collected in the same manner as in L/V testing described in Section 2.1, with the exception of solid sorbent tubes (SSTs) being utilized for sample capture rather than bubblers as the test fixture utilized would not allow for the use of bubblers. A total of 15 swatches were evaluated during this test. Fourteen (14) were challenged with HD vapor, while one was added as a negative control. V/V-specific details are provided in Sections 2.2.1 through 2.2.5.

2.2.1 V/V Testing – Preparation

Material samples were processed as described in Section 2.1.1.

2.2.2 V/V Testing – HD Vapor Generation

HD vapor generation was accomplished using a custom vapor generator. The generator contained liquid HD and a ceramic wick. The HD vapor challenge was generated by passing clean, dry air across the wick. Refer to Figure for an example generator.

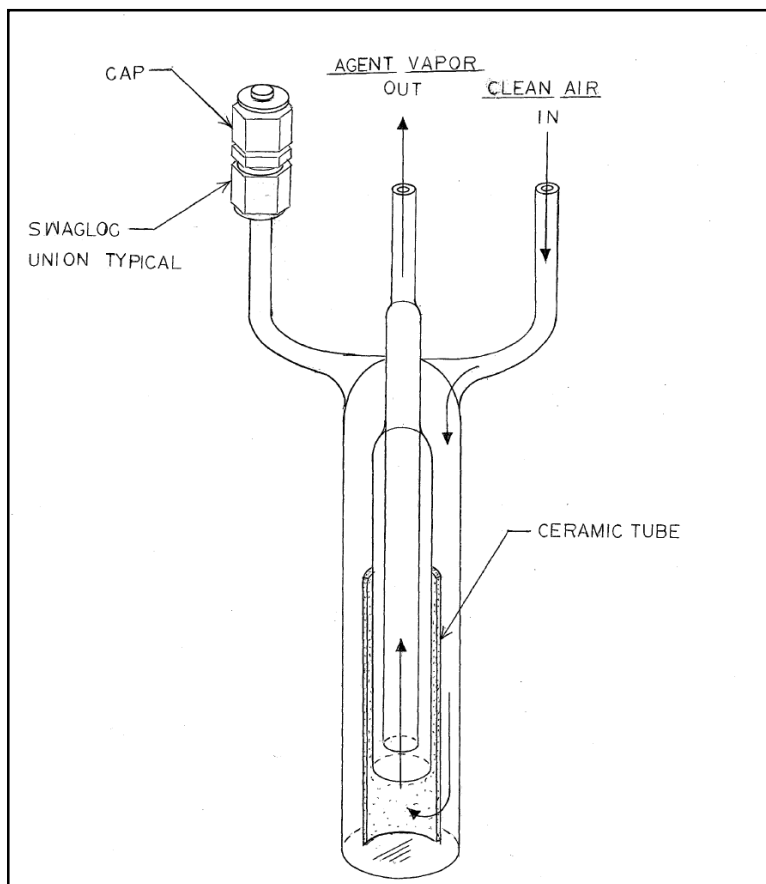

Figure 6. HMRC Custom CA Vapor Generator

The CA laden air from the generator was then mixed with a dilution airstream of clean air. This airstream was then passed through a static mixing chamber and into the test fixture supply air vapor manifold.

The HD vapor concentration was adjusted and controlled by varying the flow rates of the HD vapor generator flow and the dilution flow rate. The total flow entering the manifold was greater than the sum of the flow rates through the individual test cells. The excess HD vapor air stream was vented through a charcoal filter and into the chemical fume hood. The HD vapor concentration was monitored using a GC/FID and a sample loop. The sample loop had a fixed 1-mL volume.

A five-point calibration curve bracketing the target concentration of the HD was obtained on the GC prior to testing. Samples were continuously drawn from the HD agent vapor manifold and through the GC sample loop. Due to the run time of the GC method, sample HD vapor challenge concentrations were obtained approximately every 10 minutes, which was maintained during the entire test. The average test vapor concentration measured was 22.0 mg/m³. Refer to Figure for the vapor concentration profile.

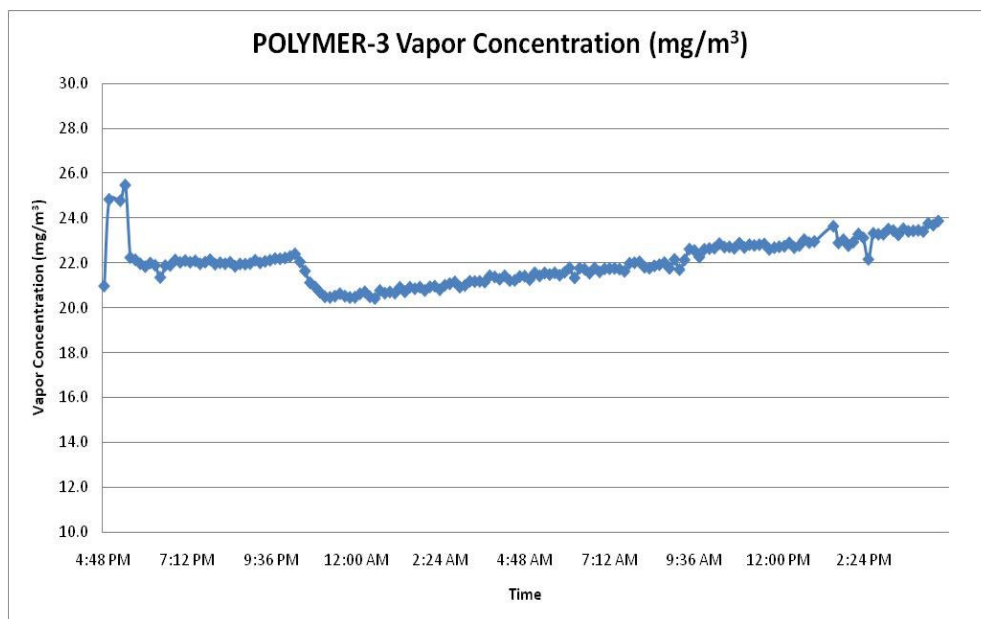

Figure 7. HD Vapor Concentration

After the HD vapor generation was initiated and concentration was stable, assembled test cells were connected to the fixture and the trial began. The top ports of each test cell were fitted to the HD vapor manifold by a Teflon[®] supply line attached to the manifold connected in-line with a critical orifice (CO) and vacuum pump. This CO maintained a constant agent flow rate of 0.1 lpm across the top of the swatch. The bottom ports of each test cell were connected to a separate clean air supply manifold that was attached in-line with a vacuum pump and another CO that maintained flow at 0.3 lpm through the SSTs. The trial was conducted at laboratory ambient temperature and relative humidity. All instruments were calibrated in accordance with HMRC SOPs.

2.2.3 V/V Testing – Sampling and Analysis

SSTs were extracted using 5.0 mL of acetone (CAS # 67-64-1) in accordance with HMRC SOPs. For each SST, the end was cut and the sorbent material emptied into a sample vial. Acetone was then added to the vial and the vial was capped and vortexed for 30 seconds. Aliquots of the solution were taken from the vial for analysis after a minimum soak time of 1 hour. Analysis via GC/FPD occurred as described in Section 2.1.3. The MDL for this test was 0.25 $\mu\text{g}/\text{cm}^2$.

2.2.4 V/V Testing – Trial Termination

Trial termination and cleanup occurred as described in Section 2.1.4. No observations were noted as to any deformation.

2.2.5 V/V Testing – Raw Data and Calculations

Data analysis and reporting occurred as described in Section 2.1.5. In summary, no permeation was detected in any sample or interval (results $<0.25 \mu\text{g}/\text{cm}^2$). Results obtained for the negative control were within specification indicating no gross system errors or trial anomalies were present. The complete data set is located in Appendix D.

2.3 Coating Reactivity Testing

Coating reactivity testing was conducted following procedures developed at the HMRC with guidance from the Chemical Decontaminant Performance Evaluation Testing Source Document (2). Swatches were challenged with neat, liquid HD at a contamination density of $10 \text{ g}/\text{m}^2$ and sealed within a test jar for a period of 24 hours at laboratory ambient environmental conditions. Refer to Table 5 for test parameters.

Table 5. Coating Reactivity Test Parameters

Parameter	Description
Pre-conditioning	Not necessary
Temperature	Laboratory ambient (69°F)
Relative humidity	Laboratory ambient (54%)
Length of test	24 hours
Sampling intervals	0 to 24 hours
Swatch sample size	10 cm^2
HD spiking method	Manual application using a $50\text{-}\mu\text{L}$ gas-tight syringe with stepper
HD challenge	8 x $1 \mu\text{L}$ drop per swatch ($1.27 \text{ mg}/\mu\text{L} \times 8 \mu\text{L} = 10.2 \pm 2.0 \text{ mg}$ over 10 cm^2 area)
HD purity	96.2%

After 24 hours, each swatch was removed from its jar and extracted in 10 mL of hexane for 1 hour. Aliquots were taken from the samples and analyzed by GC/MS.

Additionally, positive and negative control swatches were included in the test. Negative controls were material coating swatches that were not challenged with HD and enabled the detection of analytical interferences that might have been created during the extraction process. Positive controls were latex dental dam swatches that are challenged with HD in the same manner as the material swatches, but have known extraction efficiency as demonstrated in previous efforts. This control aided in the detection of gross process drifts. A single test was executed. Details are provided in Sections 2.3.1 through 2.3.6.

2.3.1 Coating Reactivity Testing – Solvent Extraction Interference Analysis

As mentioned previously, testing was conducted on material coating swatches before testing began to determine if any analytical interferences existed. Seven replicate swatches were extracted in 10 mL of hexane for 1 hour. Aliquots of the solvent were taken and spiked with 4.30 µg of HD. The resultant solution was analyzed by GC/MS and demonstrated that HD could be resolved using hexane and current analytical methods. The average recovery was 4.36 µg of HD or 101% of the challenge with a relative standard deviation (RSD) of 3%. Additionally, no interferences were detected. The full data set is located in Appendix E.

2.3.2 Coating Reactivity Testing – Preparation

Material samples were received by the HMRC TICC for processing as 10 cm² swatches. Each swatch was given an SICN and handled as described in Section 2.1.1.

Trial packages were released to a laboratory operator for trial preparation where a review was completed to ensure all samples matched the CoC. Swatches were placed inside labeled jars that matched the appropriate SICN and set aside. A total of 10 material coating swatches were tested.

2.3.3 Coating Reactivity Testing – HD Application (Spiking)

The target HD challenge was 10 g/m² and was executed as described in Section 2.1.2. Spike controls were also conducted as described in Section 2.1.2. After each swatch was spiked, a tight-fitting lid was immediately used to seal the jar to limit the amount of HD vapor that could escape. This step initiated the start of the trial. Figure depicts a swatch spiked in the jar.



Figure 8. Reactivity Testing – Post-Spike Swatch (Trial Start)

2.3.4 Coating Reactivity Testing – Sampling and Analysis

At the end of the 24-hour trial period, the lid was quickly removed and 10 mL of hexane was added to each jar. The lid was replaced and the jars were shaken. Swatches were extracted for 1 hour, at which time the vials were shaken again and aliquots of each solution transferred to GC vials for analysis. All samples were verified against the CoC prior to analysis.

In accordance with HMRC SOPs, a five-point calibration curve bracketing the target HD concentration was obtained on the GC prior to analysis. During analysis, QC checks were performed. For every fifth sample, a standard was analyzed to verify the calibration had not drifted and every tenth sample was analyzed twice, ensuring instrument precision was maintained. The sampling and analysis method was capable of detecting HD to an MDL of 0.10 µg/mL. Refer to Table 6 for solvents and GC calibration parameters used for this test.

Table 6. Coating Reactivity Testing Analytical Parameters

Parameter	Description
Extraction solvent	10 mL of Hexane
Spike controls	50 mL of hexane
GC/MS calibration range	0.1 to 15 $\mu\text{g/mL}$
r^2 value for calibration curve	$\geq 99\%$
Frequency of QC checks	Duplicate sample analyzed every tenth sample (must be within 20%)
	Standard analyzed after every fifth sample (lowest standard must be within 25%, all others within 15%)

Samples whose HD concentrations exceeded the calibration range of the GC were diluted and re-analyzed.

2.3.5 Coating Reactivity Testing – Trial Termination

After all swatches were extracted, each swatch was visually inspected prior to disposal. Similar to the observations noted during L/V testing, swatches appeared slightly deformed and warped. Figure displays the observation noted at the trials end before extraction occurred.



Figure 9. Reactivity Testing – Post-Weathering Swatch (Trial End)

All swatches were disposed of in accordance with HMRC SOPs. No swatches were saved or stored after testing.

2.3.6 Coating Reactivity Testing – Raw Data and Calculations

GC analysis of each sample for each test swatch was used to measure the mass of HD per sample ($\mu\text{g/mL}$). From the GC analysis results, the mass recovered (μg), M , was calculated as presented in Equation 2:

$$M = GC * V$$

Equation 2. Mass Recovered

Where:

- GC = measured GC result ($\mu\text{g/mL}$)
- V = sample (hexane) volume (10 mL)

As determined by the spike controls, the maximum recovery was 9.77 mg. On average, 12.12% (~1.18 mg) of the challenge was recovered from the material. While no statistical analysis was conducted, the recoveries did not appear to be dependent on thickness. Results obtained for the positive and negative controls were within specification indicating no gross system errors or trial anomalies were present. Recovery of the positive control was calculated to be 96.71% indicating minimal evaporative losses were achieved. Refer to Figure for a plot of recoveries against thickness. Refer to Appendix F for the full data set.

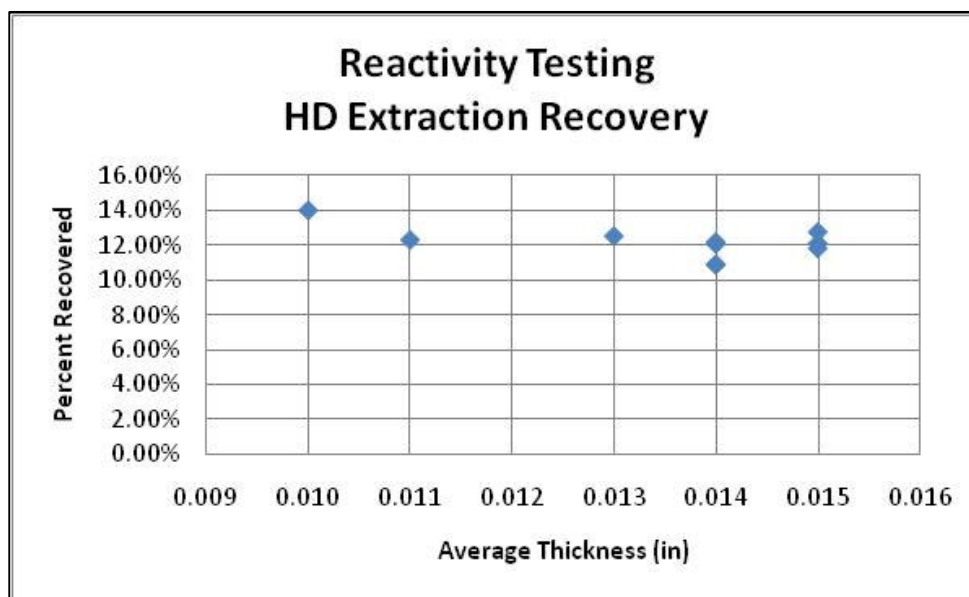

Figure 10. Reactivity Testing – HD Extraction Recovery

Finally, degradation by-products such as vinyl sulfoxide, mustard sulfoxide, and mustard sulfone produced from oxidation reactions, or thiodiglycol if hydrolysis reactions occurred, were not detected.

3.0 Safety

Safety precautions were incorporated at every level of test execution. Bailment Agreement W911 SR-10-H-0001 safety procedures, safety SOPs, facility safety procedures, as well as corporate safety procedures that establish guidelines for the handling of hazardous materials were strictly followed. Battelle conducted operational readiness inspections, safety inspections, and dry runs prior to the execution of this testing. Material Safety Data Sheets (MSDSs) for all chemicals were filed in a readily assessable designated area.

4.0 Quality Assurance

The HMRC conducted testing in accordance with quality assurance (QA) procedures described in the Battelle Quality Manual (3). The Quality Manual was the documented system of procedures used to ensure quality deliverables to clients. Program Plans, SOP's, facility procedures, worksheets, and flowcharts with supporting checklists were used as a part of internal supporting documentation requirements in accordance with the Quality Manual. The Quality Assurance Manager, Project Managers, and Principal Investigators were responsible for establishing and maintaining procedures for identifying, collecting, indexing, filing, storing, and maintaining quality records throughout the life of the program. All copies of these documents were indefinitely archived within Battelle's Records Management System.

5.0 Summary and Conclusions

5.1 Summary

The performance of POLYMERright, Inc novel coating was evaluated against HD using existing test methods described in US Army TOP 8-2-501 (1) and the Decontaminant Source Document (2) for L/V, V/V, and coating reactivity swatch testing.

5.1.1 L/V Swatch Testing

Swatches in one trial, including 28 swatches of material coating, were challenged with 10 ± 2 mg of HD over a period of 24 hours. Samples were analyzed at three intervals: 0 to 6, 6 to 16, and 16 to 24 hours. Results obtained via GC/FPD analysis were converted to mass permeation per unit area. All samples demonstrated considerable 0- to 24-hour cumulative permeation. On average $56 \mu\text{g}/\text{cm}^2$ or approximately 5% of the total challenge broke through after 24 hours. Permeation also appeared to be dependent on material thickness where HD breakthrough seemed to take longer on thicker materials and had an overall reduced magnitude. The data suggests that increasing the thickness (such as to 20-30 mil) would potentially prevent breakthrough from occurring under the test conditions described within this report. Additionally testing with thicker materials would be worth pursuing in a future task.

5.1.2 V/V Swatch Testing

Swatches in one trial, including 14 swatches of material coating, were challenged with HD vapor at a concentration of $20 \pm 4 \text{ mg}/\text{m}^3$ over a period of 24 hours. Vapor concentration was monitored via GC/FID over the course of the trial. Samples were analyzed at three intervals: 0 to 6, 6 to 16, and 16 to 24 hours. Results obtained via GC/FPD analysis were converted to mass permeation per unit area. No HD breakthrough was detected in any sample (i.e., $<0.25 \mu\text{g}/\text{cm}^2$).

5.1.3 Coating Reactivity Testing

Swatches in one trial, including 10 swatches of material coating, were challenged with 10 ± 2 mg of HD over a period of 24 hours. Swatches were extracted for 1 hour in hexane, after which samples were aliquoted and analyzed via GC/MS. Results were converted to mass recovered based on mass applied to the swatch as determined by the spike controls. On average, 12% or 1.18 mg of the applied 10 mg of HD was recovered from the material after 24 hours. Additionally, no degradation by-products were identified indicating that hydrolysis or oxidation reactions did not take place. Side-by-side reactivity testing of similar barrier/reactive coatings to POLYMERright's coating would be worth examining in a future effort.

5.2 Conclusions

The conclusions relating to the data generated under this effort will be derived by POLYMERright Inc. However, it can be stated that all testing was successfully executed in accordance with the Program Test Plan (4) and should be considered valid for evaluation. Additionally, data produced under this effort suggests over a 24 hour time period it can resist HD permeation from a 20 mg/m³ vapor challenge. The coating has also demonstrated it can significantly limit HD breakthrough to approximately 5% of a 10 g/m² challenge over a 24 hour period. As this coating is designed to be applied to structures to provide chemical protection, it is suggestive that the coating would offer protection over the same structure with no coating.

6.0 References

1. US Army Test Operations Procedure (TOP) 8-2-501. Permeation and Penetration Testing of Air-permeable, Semi-permeable, and Impermeable Materials with Chemical Agents or Stimulants (Swatch Testing). Dated January 17, 2002 with revisions on April 29, 2003.
2. The Chemical Decontaminant Performance Evaluation Testing Source Document, 2007.
3. Applied Research Laboratory Operations Quality Manual. Latest Version.
4. POLYMERight, Inc. Final Test Plan, dated July 9, 2012.

7.0 Contacts

Contact	Role	Location	Phone
Brian Blackstone	Program Manager	Battelle, West Jefferson	(614) 424-5650
Adam Judd	Relationship Manager	Battelle, King Avenue	(614) 424-5396
Edward Soja	Principal Investigator	Battelle, West Jefferson	(614) 424-5247
Shawn Shumaker	Statistician	Battelle, West Jefferson	(614) 424-3232
Russell Greene	HMRC Associate Manager	Battelle, West Jefferson	(614) 424-3714
Greg Kastner	HMRC Manager	Battelle, West Jefferson	(614) 424-4771

APPENDIX A: TEST MATRIX

Test Report for POLYMERight, Inc. Coating Agent Testing

Test Description	Chemical Agent	Number of Samples per Trial	Number of Trials
Liquid Challenge/Vapor Permeation Resistance Testing	HD	28	1
Vapor Challenge/Vapor Permeation Resistance Testing	HD	14	1
Coating Reactivity Testing	HD	10	1

APPENDIX B: SAMPLE CoC

Proj# 12345678
 Pl: Technical Staff

BATTELLE - HMRC RECORD



Category
 TEST SAMPLE CUSTODY FORM
TRIAL - SAMPLETEST RACK - 1

Relinquished By: _____ Received By: _____ Date: _____

SWATCH CONTROL CODES						IMPINGER IDENTIFICATION	
Position #	Sample Identification Code	Agent	Treatment	Method	Solvent	Sampling Intervals (hours)	
						0-12	12-24
1	SAMPLE-01	HD	JP8	Dual Flow	EGDA	AC43751	AC44052
2	CNTRL-PEBUT-04-141-NEG	NONE	None	Dual Flow	EGDA	AC43761	AC44062
3	SAMPLE-05	HD	JP8	Dual Flow	EGDA	AC43771	AC44072
4	CNTRL-PEBUT-04-143-POS	HD	None	Dual Flow	EGDA	AC43781	AC44082
5	SAMPLE-01	HD	JP8	Dual Flow	EGDA	AC43791	AC44092
6	SAMPLE-01	HD	JP8	Dual Flow	EGDA	AC43801	AC44102
7	SAMPLE-01	HD	JP8	Dual Flow	EGDA	AC43811	AC44112
8	SAMPLE-01	HD	JP8	Dual Flow	EGDA	AC43821	AC44122
9	SAMPLE-01	HD	JP8	Dual Flow	EGDA	AC43831	AC44132
10	SAMPLE-01	HD	JP8	Dual Flow	EGDA	AC43841	AC44142
11	SAMPLE-03	HD	JP8	Dual Flow	EGDA	AC43851	AC44152
12	SAMPLE-01	HD	JP8	Dual Flow	EGDA	AC43861	AC44162
13	SAMPLE-07	HD	JP8	Dual Flow	EGDA	AC43871	AC44172
14	CNTRL-PEBUT-04-145-POS	HD	None	Dual Flow	EGDA	AC43881	AC44182
15	SAMPLE-07	HD	JP8	Dual Flow	EGDA	AC43891	AC44192
16	SAMPLE-03	HD	JP8	Dual Flow	EGDA	AC43901	AC44202
17	CNTRL-PEBUT-04-140-NEG	NONE	None	Dual Flow	EGDA	AC43911	AC44212
18	SAMPLE-01	HD	JP8	Dual Flow	EGDA	AC43921	AC44222
19	SAMPLE-05	HD	JP8	Dual Flow	EGDA	AC43931	AC44232
20	SAMPLE-01	HD	JP8	Dual Flow	EGDA	AC43941	AC44242
21	SAMPLE-05	HD	JP8	Dual Flow	EGDA	AC43951	AC44252
22	SAMPLE-05	HD	JP8	Dual Flow	EGDA	AC43961	AC44262
23	CNTRL-PEBUT-04-142-NEG	NONE	None	Dual Flow	EGDA	AC43971	AC44272
24	SAMPLE-01	HD	JP8	Dual Flow	EGDA	AC43981	AC44282
25	SAMPLE-05	HD	JP8	Dual Flow	EGDA	AC43991	AC44292
26	SAMPLE-07	HD	JP8	Dual Flow	EGDA	AC44001	AC44302
27	SAMPLE-01	HD	JP8	Dual Flow	EGDA	AC44011	AC44312
28	SAMPLE-07	HD	JP8	Dual Flow	EGDA	AC44021	AC44322
29	CNTRL-PEBUT-04-144-POS	HD	None	Dual Flow	EGDA	AC44031	AC44332
30	SAMPLE-07	HD	JP8	Dual Flow	EGDA	AC44041	AC44342

Pre-Condition Time: <u>30 Minutes For Non-Treated swatches</u>	Temp: <u>90° ±2°</u>	RH: <u>80% ±5</u>
Pressure: <u>.1 iwq for Conv. 0.0 iwq DualFlow</u>	Negative	
ALL MATERIALS GET PRE/POST SEAL CHECK		

THIS FORM MUST ALWAYS REMAIN WITH THE SAMPLES UNTIL DISPOSAL

Printed on 11/18/2010

APPENDIX C: L/V PERMEATION DATA

Test Report for POLYMERight, Inc. Coating Agent Testing

Trial	Sample_ID	Average Thickness (in)	Lot	Agent	0-6 Hour ($\mu\text{g}/\text{cm}^2$)	6-16 Hour ($\mu\text{g}/\text{cm}^2$)	16-24 Hour ($\mu\text{g}/\text{cm}^2$)	0-24 Hour ($\mu\text{g}/\text{cm}^2$)
POLYMER-01	PLYRTE-POLYMER-13-79-2-14	0.0098	13-79-2	HD	33.15	75.50	16.32	124.97
POLYMER-01	PLYRTE-POLYMER-13-79-2-02	0.0100	13-79-2	HD	24.31	74.70	17.52	116.53
POLYMER-01	PLYRTE-POLYMER-13-79-2-06	0.0100	13-79-2	HD	40.75	78.90	17.19	136.84
POLYMER-01	PLYRTE-POLYMER-13-79-2-10	0.0108	13-79-2	HD	8.12	68.35	17.39	93.86
POLYMER-01	PLYRTE-POLYMER-13-79-2-05	0.0110	13-79-2	HD	2.63	61.45	16.83	80.91
POLYMER-01	PLYRTE-POLYMER-13-79-2-13	0.0110	13-79-2	HD	25.42	77.70	17.14	120.26
POLYMER-01	PLYRTE-POLYMER-13-79-2-03	0.0114	13-79-2	HD	2.32	33.85	13.38	49.55
POLYMER-01	PLYRTE-POLYMER-13-79-2-09	0.0116	13-79-2	HD	<0.50	39.65	13.56	53.21
POLYMER-01	PLYRTE-POLYMER-13-79-2-24	0.0116	13-79-2	HD	2.08	40.95	16.10	59.13
POLYMER-01	PLYRTE-POLYMER-13-79-2-04	0.0118	13-79-2	HD	<0.50	36.60	16.23	52.83
POLYMER-01	PLYRTE-POLYMER-13-79-2-07	0.0118	13-79-2	HD	1.91	37.95	14.08	53.94
POLYMER-01	PLYRTE-POLYMER-13-79-2-12	0.0120	13-79-2	HD	<0.50	24.65	12.28	36.93
POLYMER-01	PLYRTE-POLYMER-13-79-2-16	0.0120	13-79-2	HD	0.89	42.50	14.39	57.78
POLYMER-01	PLYRTE-POLYMER-13-79-2-26	0.0120	13-79-2	HD	<0.50	37.64	14.52	52.16
POLYMER-01	PLYRTE-POLYMER-13-79-2-28	0.0122	13-79-2	HD	1.54	31.10	14.18	46.82
POLYMER-01	PLYRTE-POLYMER-13-79-2-27	0.0124	13-79-2	HD	<0.50	41.05	16.65	57.70
POLYMER-01	PLYRTE-POLYMER-13-79-2-11	0.0126	13-79-2	HD	<0.50	27.65	12.68	40.33
POLYMER-01	PLYRTE-POLYMER-13-79-2-21	0.0126	13-79-2	HD	<0.50	25.17	12.99	38.16
POLYMER-01	PLYRTE-POLYMER-13-79-2-20	0.0128	13-79-2	HD	<0.50	23.41	13.83	37.24
POLYMER-01	PLYRTE-POLYMER-13-79-2-25	0.0128	13-79-2	HD	<0.50	34.20	15.53	49.73
POLYMER-01	PLYRTE-POLYMER-13-79-2-15	0.0130	13-79-2	HD	<0.50	14.56	11.78	26.34
POLYMER-01	PLYRTE-POLYMER-13-79-2-23	0.0130	13-79-2	HD	<0.50	34.35	16.13	50.48
POLYMER-01	PLYRTE-POLYMER-13-79-2-08	0.0134	13-79-2	HD	<0.50	20.39	13.47	33.86
POLYMER-01	PLYRTE-POLYMER-13-79-2-22	0.0138	13-79-2	HD	<0.50	18.42	11.06	29.48
POLYMER-01	PLYRTE-POLYMER-13-79-2-01	0.0140	13-79-2	HD	<0.50	5.83	9.32	15.15
POLYMER-01	PLYRTE-POLYMER-13-79-2-18	0.0142	13-79-2	HD	<0.50	9.05	11.12	20.17
POLYMER-01	PLYRTE-POLYMER-13-79-2-19	0.0144	13-79-2	HD	<0.50	7.35	9.40	16.75
POLYMER-01	PLYRTE-POLYMER-13-79-2-17	0.0132	13-79-2	HD	<0.50	20.68	13.72	34.40

APPENDIX D: V/V PERMEATION DATA

Test Report for POLYMERright, Inc. Coating Agent Testing

Trial	Sample_ID	Average Thickness (in)	Lot	Agent	0-6 Hour ($\mu\text{g}/\text{cm}^2$)	6-16 Hour ($\mu\text{g}/\text{cm}^2$)	16-24 Hour ($\mu\text{g}/\text{cm}^2$)	0-24 Hour ($\mu\text{g}/\text{cm}^2$)
POLYMER-03	PLYRTE-POLYMER-13-79-2-29	0.0154	13-79-2	HD	<0.25 ^a	<0.25	<0.25	<0.75
POLYMER-03	PLYRTE-POLYMER-13-79-2-30	0.0146	13-79-2	HD	<0.25	<0.25	<0.25	<0.75
POLYMER-03	PLYRTE-POLYMER-13-79-2-31	0.0112	13-79-2	HD	<0.25	<0.25	<0.25	<0.75
POLYMER-03	PLYRTE-POLYMER-13-79-2-32	0.0110	13-79-2	HD	<0.25	<0.25	<0.25	<0.75
POLYMER-03	PLYRTE-POLYMER-13-79-2-33	0.0122	13-79-2	HD	<0.25	<0.25	<0.25	<0.75
POLYMER-03	PLYRTE-POLYMER-13-79-2-34	0.0114	13-79-2	HD	<0.25	<0.25	<0.25	<0.75
POLYMER-03	PLYRTE-POLYMER-13-79-2-35	0.0138	13-79-2	HD	<0.25	<0.25	<0.25	<0.75
POLYMER-03	PLYRTE-POLYMER-13-79-2-36	0.0126	13-79-2	HD	<0.25	<0.25	<0.25	<0.75
POLYMER-03	PLYRTE-POLYMER-13-79-2-37	0.0106	13-79-2	HD	<0.25	<0.25	<0.25	<0.75
POLYMER-03	PLYRTE-POLYMER-13-79-2-38	0.0092	13-79-2	HD	<0.25	<0.25	<0.25	<0.75
POLYMER-03	PLYRTE-POLYMER-13-79-2-39	0.0108	13-79-2	HD	<0.25	<0.25	<0.25	<0.75
POLYMER-03	PLYRTE-POLYMER-13-79-2-40	0.0102	13-79-2	HD	<0.25	<0.25	<0.25	<0.75
POLYMER-03	PLYRTE-POLYMER-13-79-2-41	0.0098	13-79-2	HD	<0.25	<0.25	<0.25	<0.75
POLYMER-03	PLYRTE-POLYMER-13-79-2-42	0.0106	13-79-2	HD	<0.25	<0.25	<0.25	<0.75

^a Note: A value of <0.25 indicates no detectable HD was present in the sample.

**APPENDIX E: MATERIAL REACTIVITY INTERFERENCE
VERIFICATION**

Test Report for POLYMERright, Inc. Coating Agent Testing

POLYMER-INTERFERENCE STUDY					Result (ug/mL)	Result (ug)	% Recovery
Position	Sample ID	Agent	Challenge (µL)	Solvent	0-1 Hour	0-1 Hour	0-1 Hour
1	POLYMER-1	HD	5 uL of 1,000 ug/mL	10 mL HEXANE	0.44	4.40	98
2	POLYMER-2	HD	5 uL of 1,000 ug/mL	10 mL HEXANE	0.45	4.50	96
3	POLYMER-3	HD	5 uL of 1,000 ug/mL	10 mL HEXANE	0.41	4.10	105
4	POLYMER-4	HD	5 uL of 1,000 ug/mL	10 mL HEXANE	0.44	4.40	98
5	POLYMER-5	HD	5 uL of 1,000 ug/mL	10 mL HEXANE	0.43	4.30	100
6	POLYMER-6	HD	5 uL of 1,000 ug/mL	10 mL HEXANE	0.45	4.50	96
7	POLYMER-7	HD	5 uL of 1,000 ug/mL	10 mL HEXANE	0.43	4.30	100
8	POLYMER-8	NONE	None	10 mL HEXANE	<0.1	<1	
	SPIKE Control	HD		10 mL HEXANE	0.43	4.30	

APPENDIX F: MATERIAL REACTIVITY DATA

Test Report for POLYMERight, Inc. Coating Agent Testing

Trial Name	Sample_ID	Lot	Agent	Average Thickness (in)	Method	Mass Recovered (µg)	% Recovered (ug)
POLYMER-02	PLYRTE-POLYMER-10cm-02	13-79-2	HD	0.014	Extraction - 10 mL Hexane	1,058.9	10.84
POLYMER-02	PLYRTE-POLYMER-10cm-03	13-79-2	HD	0.015	Extraction - 10 mL Hexane	1,179.6	12.07
POLYMER-02	PLYRTE-POLYMER-10cm-04	13-79-2	HD	0.014	Extraction - 10 mL Hexane	1,176.6	12.04
POLYMER-02	PLYRTE-POLYMER-10cm-05	13-79-2	HD	0.011	Extraction - 10 mL Hexane	1,366.5	13.99
POLYMER-02	PLYRTE-POLYMER-10cm-06	13-79-2	HD	0.014	Extraction - 10 mL Hexane	1,060.4	10.85
POLYMER-02	PLYRTE-POLYMER-10cm-07	13-79-2	HD	0.013	Extraction - 10 mL Hexane	1,220.7	12.49
POLYMER-02	PLYRTE-POLYMER-10cm-08	13-79-2	HD	0.014	Extraction - 10 mL Hexane	1,151.1	11.78
POLYMER-02	PLYRTE-POLYMER-10cm-09	13-79-2	HD	0.011	Extraction - 10 mL Hexane	1,199.2	12.27
POLYMER-02	PLYRTE-POLYMER-10cm-10	13-79-2	HD	0.014	Extraction - 10 mL Hexane	1,243.2	12.72
POLYMER-02	PLYRTE-POLYMER-10cm-11	13-79-2	HD	0.015	Extraction - 10 mL Hexane	1,186.8	12.15
POLYMER-02	PLYRTE-Dental Dam POS-01	NA	HD	NA	Extraction - 10 mL Hexane	9,448.7	96.71
POLYMER-02	PLYRTE-POLYMER-10cm-01	13-79-2	HD	0.010	Extraction - 10 mL Hexane	<1.0	0.00

Max Recovery (µg)	Standard Deviation (µg)	RSD (of mass)	Geometric Mean (µg)	Average (% Recovered)
9,770.0	88.5	7%	1,181.4	12.12