

REPORT DOCUMENTATION PAGE

*Form Approved
OMB No. 0704-0188*

The public reporting burden for this collection of information is estimated to average 1 hour per response, including the time for reviewing instructions, searching existing data sources, gathering and maintaining the data needed, and completing and reviewing the collection of information. Send comments regarding this burden estimate or any other aspect of this collection of information, including suggestions for reducing the burden, to the Department of Defense, Executive Services and Communications Directorate (0704-0188). Respondents should be aware that notwithstanding any other provision of law, no person shall be subject to any penalty for failing to comply with a collection of information if it does not display a currently valid OMB control number.

PLEASE DO NOT RETURN YOUR FORM TO THE ABOVE ORGANIZATION.

1. REPORT DATE (DD-MM-YYYY)		2. REPORT TYPE		3. DATES COVERED (From - To)	
4. TITLE AND SUBTITLE				5a. CONTRACT NUMBER	
				5b. GRANT NUMBER	
				5c. PROGRAM ELEMENT NUMBER	
6. AUTHOR(S)				5d. PROJECT NUMBER	
				5e. TASK NUMBER	
				5f. WORK UNIT NUMBER	
7. PERFORMING ORGANIZATION NAME(S) AND ADDRESS(ES)				8. PERFORMING ORGANIZATION REPORT NUMBER	
9. SPONSORING/MONITORING AGENCY NAME(S) AND ADDRESS(ES)				10. SPONSOR/MONITOR'S ACRONYM(S)	
				11. SPONSOR/MONITOR'S REPORT NUMBER(S)	
12. DISTRIBUTION/AVAILABILITY STATEMENT					
13. SUPPLEMENTARY NOTES					
14. ABSTRACT					
15. SUBJECT TERMS					
16. SECURITY CLASSIFICATION OF:			17. LIMITATION OF ABSTRACT	18. NUMBER OF PAGES	19a. NAME OF RESPONSIBLE PERSON
a. REPORT	b. ABSTRACT	c. THIS PAGE			19b. TELEPHONE NUMBER (Include area code)

INSTRUCTIONS FOR COMPLETING SF 298

1. REPORT DATE. Full publication date, including day, month, if available. Must cite at least the year and be Year 2000 compliant, e.g. 30-06-1998; xx-06-1998; xx-xx-1998.

2. REPORT TYPE. State the type of report, such as final, technical, interim, memorandum, master's thesis, progress, quarterly, research, special, group study, etc.

3. DATES COVERED. Indicate the time during which the work was performed and the report was written, e.g., Jun 1997 - Jun 1998; 1-10 Jun 1996; May - Nov 1998; Nov 1998.

4. TITLE. Enter title and subtitle with volume number and part number, if applicable. On classified documents, enter the title classification in parentheses.

5a. CONTRACT NUMBER. Enter all contract numbers as they appear in the report, e.g. F33615-86-C-5169.

5b. GRANT NUMBER. Enter all grant numbers as they appear in the report, e.g. AFOSR-82-1234.

5c. PROGRAM ELEMENT NUMBER. Enter all program element numbers as they appear in the report, e.g. 61101A.

5d. PROJECT NUMBER. Enter all project numbers as they appear in the report, e.g. 1F665702D1257; ILIR.

5e. TASK NUMBER. Enter all task numbers as they appear in the report, e.g. 05; RF0330201; T4112.

5f. WORK UNIT NUMBER. Enter all work unit numbers as they appear in the report, e.g. 001; AFAPL30480105.

6. AUTHOR(S). Enter name(s) of person(s) responsible for writing the report, performing the research, or credited with the content of the report. The form of entry is the last name, first name, middle initial, and additional qualifiers separated by commas, e.g. Smith, Richard, J, Jr.

7. PERFORMING ORGANIZATION NAME(S) AND ADDRESS(ES). Self-explanatory.

8. PERFORMING ORGANIZATION REPORT NUMBER. Enter all unique alphanumeric report numbers assigned by the performing organization, e.g. BRL-1234; AFWL-TR-85-4017-Vol-21-PT-2.

9. SPONSORING/MONITORING AGENCY NAME(S) AND ADDRESS(ES). Enter the name and address of the organization(s) financially responsible for and monitoring the work.

10. SPONSOR/MONITOR'S ACRONYM(S). Enter, if available, e.g. BRL, ARDEC, NADC.

11. SPONSOR/MONITOR'S REPORT NUMBER(S). Enter report number as assigned by the sponsoring/monitoring agency, if available, e.g. BRL-TR-829; -215.

12. DISTRIBUTION/AVAILABILITY STATEMENT. Use agency-mandated availability statements to indicate the public availability or distribution limitations of the report. If additional limitations/ restrictions or special markings are indicated, follow agency authorization procedures, e.g. RD/FRD, PROPIN, ITAR, etc. Include copyright information.

13. SUPPLEMENTARY NOTES. Enter information not included elsewhere such as: prepared in cooperation with; translation of; report supersedes; old edition number, etc.

14. ABSTRACT. A brief (approximately 200 words) factual summary of the most significant information.

15. SUBJECT TERMS. Key words or phrases identifying major concepts in the report.

16. SECURITY CLASSIFICATION. Enter security classification in accordance with security classification regulations, e.g. U, C, S, etc. If this form contains classified information, stamp classification level on the top and bottom of this page.

17. LIMITATION OF ABSTRACT. This block must be completed to assign a distribution limitation to the abstract. Enter UU (Unclassified Unlimited) or SAR (Same as Report). An entry in this block is necessary if the abstract is to be limited.

Final Report: AFOSR FA9550-09-1-0330

AF-Metastable Electronically Excited Atoms and Molecules: Excitation Transfer in Slow Collisions, Probed by Means of a Counter-Rotating Supersonic Jet

Principal Investigator: Robert W. Field, Department of Chemistry, Massachusetts Institute of Technology

Period: 1 March 2009-31 May 2012

Personnel: Robert W. Field (Principal Investigator), Samuel H. Lipoff (Research Assistant, withdrawn from MIT 1 July 2010), Kyle L. Bittinger (Research Assistant, PhD January 2009), Wilton L. Virgo (Martin Luther King Postdoctoral Fellow, MIT; Assistant Professor, Wellesley College, July 2008-), Monika Ciuba (Research Assistant, withdrawn from MIT, 31 August 2011), David D. Grimes (Research Assistant, NDSEG Graduate Fellow September 2012-).

Publications:

1. R. W. Field, J. Baraban, S. H. Lipoff and A. R. Beck, "Effective Hamiltonians" in *Handbook of High-Resolution Spectroscopies*, M. Quack and F. Merkt, editors, John Wiley & Sons (2010).
2. K. L. Bittinger and R. W. Field, "Deconvolution of spectral data using a doorway-coupling model Hamiltonian," *J. Chem. Phys.* **132**, 134302/1-9 (2010).
3. K. L. Bittinger, W. Virgo, and R. W. Field, Time-Dependent Center-of-Gravity Metric Determines Key Dynamical Features of Doorway-Mediated Intersystem Crossing *J. Phys. Chem. Lett.* **1**, 2144 - 2148 (2009).
4. K. Bittinger, W. Virgo and R. W. Field, "Spectral Signatures of Inter-System Crossing Mediated by Energetically Distant Doorway Levels: Examples from the Acetylene S_1 State," *J. Phys. Chem. A* (feature article) **115**, 11921-11943 (2011).
5. S. H. Lipoff and D. R. Herschbach, "Low-Energy Limit for Tunneling Subject to an Eckart Potential Barrier," *Mol. Phys.* (invited article) **108**, 1133-1143 (2010).

Paper #4 summarizes what has been a major focus of our AFOSR supported project for the last 10 years: the mechanisms of Intersystem Coupling (ISC, spin-orbit interaction between singlet and triplet states) and how these mechanisms may be experimentally characterized. Throughout this project, the spin-orbit interaction of the acetylene S_1 state with the T_1 , T_2 , and T_3 electronic states has been the primary subject of our Laser Induced Fluorescence (LIF) and Surface Electron Ejection by Laser Excited Metastables (SEELEM) experiments, largely because we have accumulated an unprecedentedly complete description of the vibrational levels of the S_1 state up to the top of the *trans-cis* isomerization barrier. As a result, the

completeness with which the ISC dynamics in acetylene is experimentally characterized is unequalled in any other four-atom or larger molecule.

Change of Research Direction

The graduate student who initiated the cold-collision project and the collaboration with Professor Dudley Herschbach realized that his progress toward a functioning experiment was unacceptably slow. He decided to write a Master's Thesis and depart from MIT. This thesis would have contained crucial information about the counter-rotating supersonic jet apparatus that we moved from Herschbach's lab at Harvard into the Field lab at MIT. Such information might have made it possible for a new graduate student to assume "ownership" of the cold-collision project. But the Master's Thesis was never completed and all communication has inexplicably been terminated. Therefore, the cold-collision project has been abandoned. In its stead, we have been pursuing a powerful new spectroscopic method, Chirped Pulse Millimeter Wave (CPmmW) spectroscopy, pioneered by Brooks Pate's research group at the University of Virginia. A linear-in-time frequency-chirped mmW $\pi/2$ pulse polarizes all two-level systems that lie within the frequency range of the chirp. These polarizations decay by Free Induction Decay at their resonance frequency. The FID signals are down-converted by mixing with a Local Oscillator and averaged in the time domain on a 12 GHz bandwidth oscilloscope.

CPmmW combines sensitivity, broad bandwidth search capability, and high resolution. Since CPmmW is a pulsed technique that captures the entire spectrum ($\sim 10^4$ 1 MHz resolution elements) in a single 10 GHz (1 microsecond) shot, it is uniquely suited for few-event applications. It is capable of distinguishing species, conformers, and vibrational levels and determining accurate (1%) relative populations. We have used CPmmW to produce and detect FID signals from 5 kilo-Debye Rydberg-Rydberg electronic transitions (Rydberg particles at 10^5 /cm³ in a 100 cm³ volume) and from 1 Debye pure rotational transitions (also in a 100 cm³ active volume). We are eager to apply CPmmW spectroscopy to systems of interest to the Air Force.

We have designed and tested a new class of molecule source for our CPmmW spectrometer, in which species of interest enter the gas phase by laser ablation, laser initiated detonation, laser vaporization (much gentler than laser-ablation), or reactions accompanying warming of a cryogenic matrix of an energetic material, such as a co-deposited REDOX combination. The sensitivity of CPmmW spectroscopy is proportional to T^{-2} , thus it is essential to employ supersonic jet cooling to $T \sim 5$ K. This new source would complement our present pyrolysis jet, discharge slit-jet, photolysis slit-jet, and photoablation jet sources. The target species entrained in the inert gas carrier expands into vacuum and is typically cooled to translational and rotational temperatures below 5K.

In order to study large densities of cold, slow molecules, we have designed, tested, and begun construction of a new pulsed molecular beam source known as a buffer

gas cooled photoablation source. A schematic outline of the technique as implemented is shown in the **Figure**. The goal of buffer gas cooling is to mix two gases inside a cooling cell: a “hot” species of interest and a “cold” buffer gas. In this case, the species of interest is formed in an ablation process that leaves the ablated products at a range of temperatures in excess of 1000 K. The buffer gas (neon) is cooled to 20 K (by a closed cycle Helium refrigerator), just above its condensation point, and continuously flowed into and through the cooling cell at a rate of 20 standard cubic centimeters per minute (sccm). The species of interest is therefore introduced into the cooling cell in the presence of a high density of the cold buffer gas, and quickly thermalizes through elastic collisions. The combined, now 20 K gas of both species is drawn out of the cell into a high vacuum formed by cryopumping and into a detection zone. Depending on the flow conditions, the molecular beam can then experience further, isentropic cooling to ~ 5 K upon extraction from the cooling cell, in a similar manner to a supersonic expansion.

We have tested this buffer gas cooling scheme has been tested on a target of calcium metal, probing the photoablated Ca atoms using a photomultiplier tube (PMT) to detect laser induced fluorescence on the 5p-4s atomic transition in order to measure the Ca beam flux. Absolute number densities of Ca atoms excited in each pulse were determined through comparison of the detected voltage from the PMT with known quantum efficiency and PMT gain curves. The results

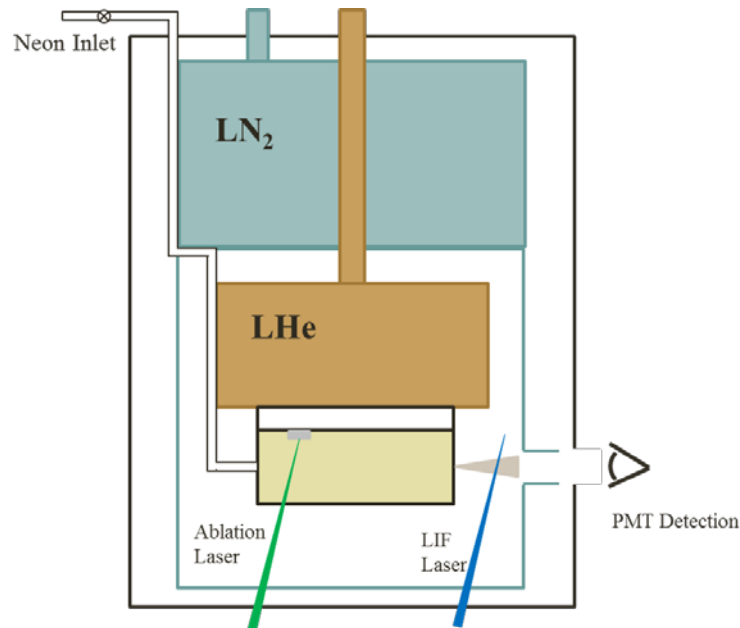

Figure: A schematic diagram of the buffer gas cooling process. The cooling was initially achieved with a liquid helium cryostat (being replaced by a closed cycle He refrigerator in the apparatus under construction). A liquid nitrogen bath is used to provide radiation shielding to protect the cooling cell from room temperature blackbody radiation. The neon inlet is controlled through use of a flow controller, maintaining a 20 sccm flow. The probe (LIF) laser for characterization of the beam is propagated through the radiation shield, and the fluorescence is detected with an external photomultiplier tube (PMT).

demonstrated that at least two orders of magnitude more atoms per ablation pulse are entrained in the buffer gas cooled beam than in a standard supersonic jet ablation source (see **Table**). Similar experiments have been performed on a variety of molecular targets, and similar increases in entrainment from a buffer gas cooled source over supersonic expansions have been observed in all cases.

In addition to this increase in particles/pulse provided by the buffer gas cooling method, many of the advantages of supersonic expansions are retained, such as low translational and rotational temperatures. Low rotational temperatures in particular are important for improving signal strength as the total population is distributed over fewer quantum states. Additionally, the fluctuations in the number of particles entrained per pulse are much smaller and the lab frame velocity of the beam is significantly slower, leading to significantly less longitudinal transient broadening and transverse Doppler broadening, which limit the resolution and sensitivity of CPmmW spectroscopy. For heavier molecules, there is also a velocity-induced angular narrowing of the cold molecular beam, which both increases the axial number density of the beam, but also further reduces the transverse Doppler broadening. The characteristics of the buffer gas cooling method, and comparisons to other common methods for vaporizing solid materials into the gas phase, are displayed in the **Table**.

This technique allows for the production of very cold molecular beams from any room temperature solid at much higher densities and lower lab frame velocities than had been previously possible. In particular, highly energetic materials such as explosives or fuels could be used in place of an ablation target and an ignition/detonation process would take place instead. The products of this process could then be analyzed by Chirped Pulse mm-Wave spectroscopy to determine the products, and therefore the mechanism, of the ignition.

	Effusion-type Oven	Supersonic Expansion	Collisional Cooling
Beam Velocity	0.2 – 0.8 mm/ μ s	1 – 2 mm/ μ s	0.1 – 0.2 mm/ μ s
Translational Temperature	500 – 2000 K	1 – 5 K	5 – 10 K
Rotational Temperature	500 – 2000 K	1 – 5 K	5 – 10 K
Particles/Pulse	CW	$\sim 10^{10}$	$> 10^{12}$
Peak Number Density (particles/cm³)	$\sim 10^{10}$	$\sim 10^8$	$> 10^{10}$
Stability	$\sim 5\%$	$\sim 40\%$	$\sim 5\%$
Particles/Quantum State	$\sim 10^7 - \sim 10^8$	$\sim 10^8$	$\sim 10^9 - \sim 10^{10}$
Doppler Broadening @ 100 GHz (kHz)	~ 400	~ 400	~ 40

Table: Comparisons between three methods of creating gas phase samples from room temperature solid materials. All species-dependent values are calculated for the case of calcium atoms, or calcium monofluoride for molecular values (rotational temperature and particles/quantum state).

