

Model-Based Fault Diagnosis in Electric Drives Using Artificial Neural Networks

M. Abul Masrur¹, ZhiHang Chen², BaiFang Zhang², Hongbin Jia², Yi L. Murphey²,

¹U. S. Army RDECOM-TARDEC, ²Department of Electrical and Computer Engineering, The University of Michigan-Dearborn

Abstract--A model based fault diagnostics study of the power electronics inverter based electrical drive is proposed. The power electronics inverter is considered to be the weakest link in such a system, hence the focus of the work is initially on fault conditions of the inverter. A faulted model for the inverter and the motor is used to generate various fault condition data, which are then compared against data generated by a normally functioning model. An artificial neural network is used to detect these faults based on features extracted from signals. The technique is viable for quick fault detection, and also the time of a fault. The concepts introduced in the paper can be effectively applied for real-time fault diagnostics in electric and hybrid vehicles, and other applications where electrical drives are used.

Key words – model-based diagnostics, power electronics, inverter, motor, electric drives, neural network, fuzzy techniques, electric vehicle, hybrid vehicle, field oriented control.

I. INTRODUCTION

The automotive industry has been paying significant attention for over a decade on electric vehicles (EV) and hybrid electric vehicles (HEV) [1,2]. These vehicles help reduce harmful emissions and also contribute to fuel economy. The main components in these vehicles are the electric drive and the power electronics based inverter, together with the necessary control system. The trend in the industry is to use 3-phase induction motor for the electric drive, since this is a very robust motor [1]. However, controlling these motors to provide precise torque has been made possible due to the power electronics based control, using in particular the Field Oriented Control or FOC [3-7] techniques. The control is realized by switching the solid state electronic switches (e.g. IGBT, MOSFET etc.) on or off, generally using some form of pulse width modulation (PWM) technique [8]. Essentially the concept is that, in response to some control algorithm, a reference voltage is generated, and the inverter tries to synthesize this voltage reference command using some PWM technique. In addition, there is the space-vector modulation technique, which uses an optimal switching mechanism to realize the voltage reference command [4]. Either way, the ultimate result is that the solid-state switches are turned on or off, depending on the gating signals to the switch. Obviously, if the switches fail to function in the way it was intended to, the voltage synthesis process will be impaired, which will lead to failure in getting the proper voltage at the motor terminals, and hence the failure in

Report Documentation Page

Form Approved
OMB No. 0704-0188

Public reporting burden for the collection of information is estimated to average 1 hour per response, including the time for reviewing instructions, searching existing data sources, gathering and maintaining the data needed, and completing and reviewing the collection of information. Send comments regarding this burden estimate or any other aspect of this collection of information, including suggestions for reducing this burden, to Washington Headquarters Services, Directorate for Information Operations and Reports, 1215 Jefferson Davis Highway, Suite 1204, Arlington VA 22202-4302. Respondents should be aware that notwithstanding any other provision of law, no person shall be subject to a penalty for failing to comply with a collection of information if it does not display a currently valid OMB control number.

1. REPORT DATE 08 DEC 2003		2. REPORT TYPE Journal Article		3. DATES COVERED 07-11-2003 to 07-12-2003	
4. TITLE AND SUBTITLE Model-Based Fault Diagnosis in Electric Drives Using Artificial Neural Networks				5a. CONTRACT NUMBER	
				5b. GRANT NUMBER	
				5c. PROGRAM ELEMENT NUMBER	
6. AUTHOR(S) M Masrur; ZhiHang Chen; BaiFang Zhang; Hongbin Jia; Yi Murphey				5d. PROJECT NUMBER	
				5e. TASK NUMBER	
				5f. WORK UNIT NUMBER	
7. PERFORMING ORGANIZATION NAME(S) AND ADDRESS(ES) The University of Michigan-Dearborn, Department of Electrical and Computer Engineering, 4901 Evergreen Road, Dearborn, Mi, 48128				8. PERFORMING ORGANIZATION REPORT NUMBER ; #13968	
9. SPONSORING/MONITORING AGENCY NAME(S) AND ADDRESS(ES) U.S. Army TARDEC, 6501 East Eleven Mile Rd, Warren, Mi, 48397-5000				10. SPONSOR/MONITOR'S ACRONYM(S) TARDEC	
				11. SPONSOR/MONITOR'S REPORT NUMBER(S) #13968	
12. DISTRIBUTION/AVAILABILITY STATEMENT Approved for public release; distribution unlimited					
13. SUPPLEMENTARY NOTES					
14. ABSTRACT A model based fault diagnostics study of the power electronics inverter based electrical drive is proposed. The power electronics inverter is considered to be the weakest link in such a system, hence the focus of the work is initially on fault conditions of the inverter. A faulted model for the inverter and the motor is used to generate various fault condition data, which are then compared against data generated by a normally functioning model. An artificial neural network is used to detect these faults based on features extracted from signals. The technique is viable for quick fault detection, and also the time of a fault. The concepts introduced in the paper can be effectively applied for real-time fault diagnostics in electric and hybrid vehicles, and other applications where electrical drives are used.					
15. SUBJECT TERMS model-based diagnostics, power electronics, inverter, motor, electric drives, neural network, fuzzy techniques, electric vehicle, hybrid vehicle, field oriented control.					
16. SECURITY CLASSIFICATION OF:			17. LIMITATION OF ABSTRACT Same as Report (SAR)	18. NUMBER OF PAGES 24	19a. NAME OF RESPONSIBLE PERSON
a. REPORT unclassified	b. ABSTRACT unclassified	c. THIS PAGE unclassified			

obtaining the requisite torque at the motor shaft. The failure of the switches can take place in the form of “open circuit” or “short circuit” faults. The reverse diodes in the switches can fail too, although we will focus in this work on the forward switches, in order to illustrate the methodology and without loss of generality.

In addition to the inverter, the motor itself can fail as well. The motor, however, is a more robust device compared to the inverter. The motor's windings can, however, deteriorate with time, and become either open or shorted, fully or partially. If the motor windings open or get shorted, it will fail to generate the proper shaft torque or even no torque at all, in spite of the fact that the inverter is in good condition and is applying the proper voltage input to the motor. Hence, it is apparent that the electrical drive can malfunction depending on whether the inverter or the motor is faulty. Of course, other problems like controller malfunctioning due to hardware or software problems can also take place. However, in this work we will focus primarily on the inverter problems, since as noted earlier, the inverter can be considered to be the weakest link in the system. In this work, for illustration, we will specifically consider open circuit and short circuit faults (rather, post-short-circuit fault, to be more precise) in an inverter switch. Post-short-circuit fault implies that if a particular switch of the inverter is short circuited, very shortly thereafter the other inverter switch located on the same limb will be gated to become on, leading to a complete short circuit of the limb. Thus, the end result will be that the complete limb of the inverter where the short circuit occurred will burn out and become open. We will also assume that only one switch can fail at a time, and that the probability of multiple failures at an instant is only of 2nd or higher order, in terms of importance. The goal of the work is to be able to diagnose the problem, locate the fault, and point towards the possible cause.

To perform the above, this work proposes a model based diagnostics. In order to achieve this, a model of the power electronics based inverter and the 3-phase induction motor, along with its control system, is developed using the Matlab-Simulink software. An open circuit (and later on a post-short-circuit) fault is introduced in one of the switches. It should be noted that in diagnostic work, the objective is not to do some fast control, rather to find out the problem, in an off-line mode if necessary. Although not a part of this work, in some cases it is possible to reconfigure the system based on the nature of the fault, so that a gracefully degradable [9-10] operation of the drive is possible.

A. State of the art

There exists a good amount of work in the literature [11,12] on model-based diagnostics of internal combustion (IC) engine vehicles. However, for electric or hybrid vehicles, the information is not as abundant. The main reason for this is that the experience of the automotive industry with such vehicles is relatively small, compared to IC engine vehicles. Some limited amount of work on electrical system diagnostics is available in the literature [13-15]. One of these [13] is about a brushless dc machine and uses a black box type of model and tries to develop the model using a polynomial differential-algebraic equation type of scheme. The idea in this work is to estimate the parameters of the system under normal and faulted conditions, and if there is any discrepancy, then a fault condition is declared. However, parameter-estimated model of this kind can easily lose the intuitive focus of the system, and in general cannot point towards the specific problem and its location. In addition, sometimes the model can encounter a topological change after a fault, and hence the premises based on which the model was originally developed and the parameters estimated, may not hold anymore. The work described in [14] is basically based on the direct comparison of voltages measured at certain key points of the system and pertains to an electric drive with open loop control. Although the work indicated above are excellent contributions to the technology, there are certain important qualitative attributes in the system, which ought to be considered in order to make a reasonable diagnostic study. It is the belief of the authors that since the direct measurement of data in electric drives is a time consuming and costly mechanism, to create a fault diagnostic algorithm it is important to resort to physical model based system. In addition, the authors believe that the model should preferably be physics based rather than black-box type parameter estimation models, in order to have good intuitive focus on the mechanism undergoing in the system.

The work described here pertains to a closed loop field oriented control electric drive, and uses a multiple qualitative attributes of various signals, like the maximum and minimum values of the voltages and currents in all phases, the average of the voltages and currents in all phases, and torque. Since these information will change depending on the exact location and type of the fault (it should be noted that the faults can be “similar”, e.g. an open fault in phase “A” is “similar” to an open fault in phase “B”, but not “same”), using these information, the neural network can detect the cause and location of the problem, assuming it is trained over a reasonable amount of operating space under different fault conditions. The authors feel that this

work will add to the existing state of the art, and they plan to extend it further in future by considering other faults, besides those in the inverter (e.g. motor and controller), and come up with reconfiguration methodologies which can lead to graceful degradation of the system rather than complete failure.

B. Statement of the problem and brief outline of the work

In order to acquire data for fault diagnosis, it is necessary to have sensors to collect the data. In the inverter, for the open circuit fault condition, if there were current sensors corresponding to every single switch and reverse diode, then one could immediately tell whether a particular switch is faulty or not, as well as the fault location, assuming that the sensor did not fail as well. In that case one would not need any sophisticated fault diagnostics algorithm. However, since the real-life inverters do not contain sensors in that way, which will not be cost/weight effective (and in general, only 3 output terminals are made available from an inverter, with no internal sensors), the goal of the work is to use only minimal amount of current and voltage sensors in the system. Voltage sensors being less costly, it would be ideal if the use of voltage sensors could replace the current sensors for the purpose of diagnostics, but sometimes that is not possible. In our system model we will assume that there are current sensors in series with any two of the inverter output lines (which, in our case, is same as the motor phases), and two voltage sensors across any two of the output terminals of the inverter (same in our case to the terminals of the induction motor). We will also assume a Y-connected 3-phase induction motor stator, without any return connection from the neutral of the Y. It should be noted that in a 3-phase Y-connected system, only two current and voltage sensors are sufficient, since the three currents or voltages add up to zero. Additional current or voltage information besides these two will not be independent in that case. However, in artificial neural network based solutions, sometime it is beneficial to simultaneously provide both dependent and independent information as the input to the neural network, which can lead to better results in classification problems. With this background, the statement of the core of our problem can be worded as follows: *“For a 6-switch inverter driven 3-phase induction motor, given two current sensors in the output inverter lines, and two voltage sensors across the lines, identify the faulty inverter switch among the six switches, assuming the switch has a fault, and that only one out of six switches can fail at a time”*.

For this purpose, we have developed a model based diagnostic framework, using signal analysis and artificial neural network. Two sets of experiments have been conducted involving the closed loop field oriented control with sine triangle PWM. The simulation model of the electric drive was performed at selected (reference commanded) torque-speed operating points, at both normal and faulty conditions. One experiment shows the diagnostic performance of the neural network system when one inverter switch in open circuit condition, and another experiment shows the performance during post-short-circuit condition. It should be noted that the chosen inverter PWM scheme and the control mechanism (open or closed loop) significantly influence the signature of the output data (voltage, currents, torque etc.). Hence it is believed that the neural network approach taken in this work will lead to a generalized methodology, which can be used in different situations involving different drive control schemes. Although the present work is focused on closed loop FOC drives, the methodology is equally applicable for other situations as well, and we will report those in our future publications.

Various data, e.g. instantaneous values of the voltages, currents, and torques have been collected and processed in order to extract certain qualitative attributes of these signals, namely the maximum, minimum, mean, standard deviation, average, and zero-frequency component of the power spectrum for these variables in all three phases. We have developed a multi-class neural network system that has the capability of classifying normal operation conditions, as well as six faulty conditions. We will show that the neural network system performs extremely well, not only on the operating points where the training data were generated, but also on the other operating points in the torque speed space. It should be noted that in our future work, which is currently ongoing, we will be introducing other types of faults besides those noted earlier, and the artificial neural network methodology will be used to diagnose those faults, along with their location. The methodology indicated in this work is generic enough for the purpose.

II. MODEL OF THE ELECTRIC DRIVE SYSTEM FOR FAULT-DIAGNOSTICS STUDY

The structure of the electric drive system in an EV or HEV using an induction motor is shown in Figure 1, which shows a closed loop system. Only a brief description will be given below, and the details of the control are omitted, since those are not within the scope of this work and our emphasis is on the results related to fault inception and diagnosis. The reader is referred to the citations in the references [1-8].

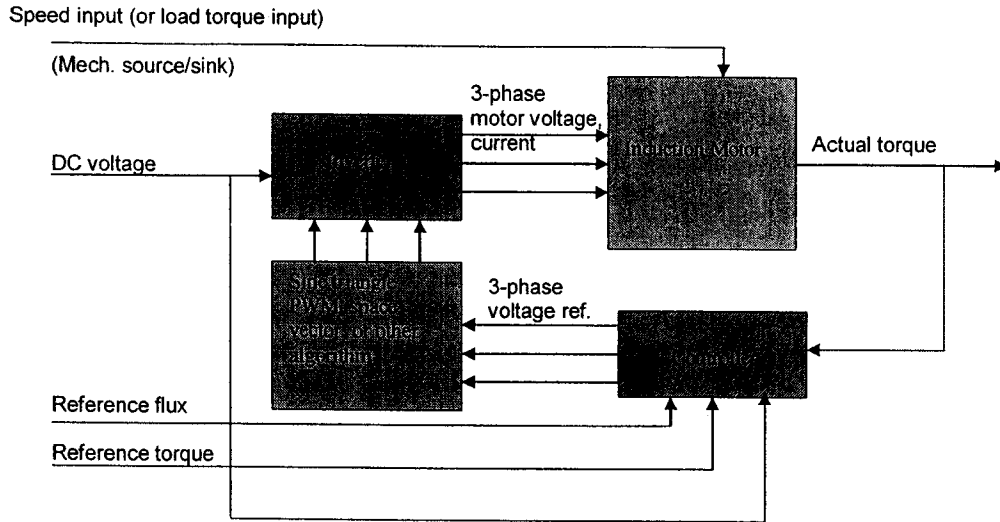

Figure 1. The block diagram of the electric drive system

In this system, the inputs are the dc voltage, reference torque, reference air gap magnetic flux in the induction motor, and the mechanical source/sink input in the form of shaft speed or load torque in the shaft. The actual electromechanical torque is the only feedback variable, which is compared against a reference, and the control action is taken accordingly. The controller is a FOC [3-7], which processes an algorithm and generates a reference 3-phase voltage. This reference voltage is then fed to the inverter pulse width modulation algorithm, which can be a sine triangle, space vector, or variable frequency bang-bang type etc. [4, 8]. In the open loop configuration, the feedback torque loop shown in Figure 1 is not used, and the controller simply generates a voltage and frequency reference, using a scheme such as a constant volts per hertz (V/Hz) type of control. The output of the controller will then go to the modulation block preceding the inverter.

The motor electrical system is described by the following set of differential and algebraic equations [3, 5-7]:

$$\begin{bmatrix} \dot{\lambda}_{as} \\ \dot{\lambda}_{bs} \\ \dot{\lambda}_{ar} \\ \dot{\lambda}_{br} \end{bmatrix} = \begin{bmatrix} -R_s & 0 & 0 & 0 \\ 0 & -R_s & 0 & 0 \\ 0 & -\omega L_m & -R_r & -\omega L_r \\ -\omega L_m & 0 & \omega L & -R_r \end{bmatrix} \begin{bmatrix} i_{as} \\ i_{bs} \\ i_{ar} \\ i_{br} \end{bmatrix} + \begin{bmatrix} V_{xs} \\ V_{ys} \\ 0 \\ 0 \end{bmatrix} \quad (1)$$

$$\text{Electromagnetic torque} = T_e = (3/2) (P/2) L_m (i_{bs} i_{ar} - i_{as} i_{br}) \quad (2)$$

The mechanical equation of motion for the motor shaft is given by:

$$T_e - T_L = P/2 [J (d\omega /dt) + B\omega] \quad (3)$$

In equations (1) to (3), the variables are: V_{xs}, V_{ys} = direct (x) and quadrature (y) axis stator frame of reference components of the instantaneous a,b,c stator phase voltages. $\lambda_{as}, \lambda_{bs}, \lambda_{ar}, \lambda_{br}$ are the stator and rotor flux linkages where the subscripts a and b refer to direct and quadrature axis voltages. T_L is the load torque, P is the number of poles in the machine, J is the moment of inertia, B is the friction coefficient, and ω is the electrical speed in radian/sec. R_s, R_r, L_s, L_r are the stator and rotor resistances and inductances respectively, and L_m is the mutual inductance.

In order to solve for currents based on equation (1), the derivative of current i is written in terms of the derivative of the flux linkage λ as follows:

$$\begin{bmatrix} \dot{i}_{as} \\ \dot{i}_{bs} \\ \dot{i}_{ar} \\ \dot{i}_{br} \end{bmatrix} = 1/L_{sr m} \begin{bmatrix} L_r & 0 & -L_m & 0 \\ 0 & L_r & 0 & L_m \\ 0 & L_s & 0 & -L_m \\ -L_m & 0 & L_s & 0 \end{bmatrix} \begin{bmatrix} \dot{\lambda}_{as} \\ \dot{\lambda}_{bs} \\ \dot{\lambda}_{ar} \\ \dot{\lambda}_{br} \end{bmatrix} \quad (4)$$

where $L_{sr m} = (L_s L_r - L_m^2)$.

This equation is then numerically solved for currents, by implementing the model using Matlab-Simulink.

In our model, the sine-triangle PWM is used. Specifically, we intend to simulate various faults for the six-switch scheme shown in Figure 2. The various states of the switches and the corresponding voltage applied to the motor are indicated in the following tables.

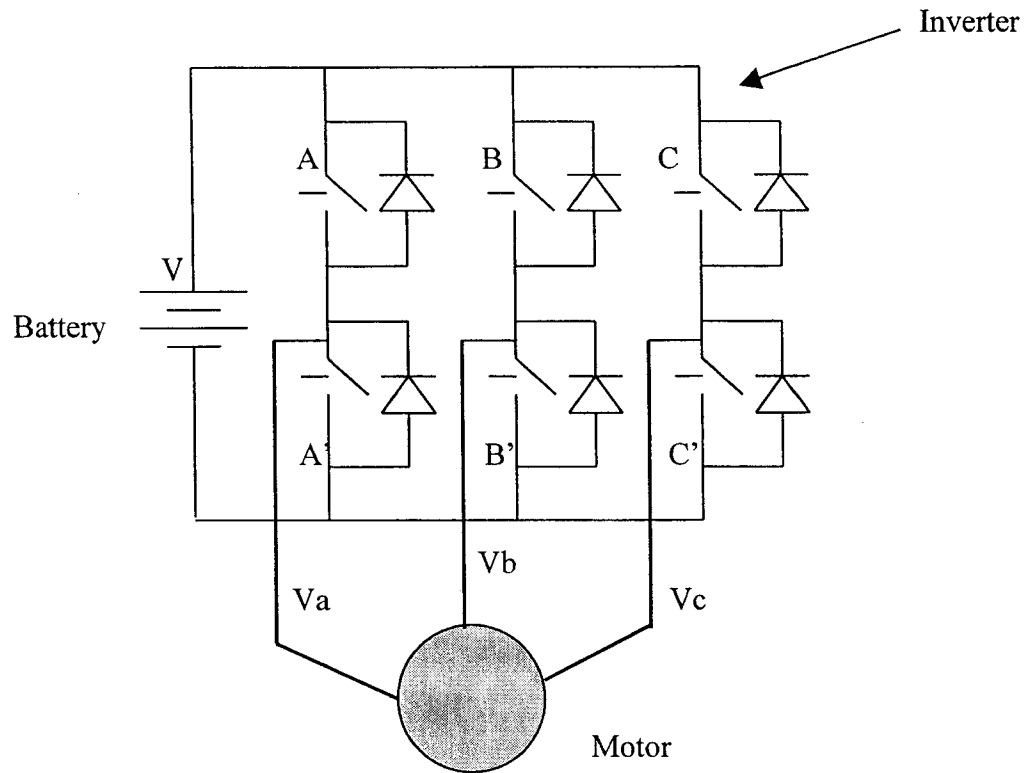

Figure 2. A six-switch inverter scheme.

Table 1 shows the normal operation of the scheme shown in Figure 2. The numbers in the voltage columns are to be multiplied with the dc voltage V , in order to obtain the true voltage applied to the motor phase windings between line and neutral. In the implementation, we assume that a gating signal 1 to a switch implies that the switch is turned on, and 0 implies that the switch is turned off. We also assume that if the upper switch A is on, then the lower switch A' will be off, and vice versa, to prevent any possibility of direct short circuit of the dc voltage source.

Table 1: Switching table for normal operation of the switches

STATE #	SWITCH A	SWITCH B	SWITCH C	V_{an} / V	V_{bn} / V	V_{cn} / V
Null	0	0	0	0	0	0
1	0	1	0	-1/3	2/3	-1/3
2	0	1	1	-2/3	1/3	1/3
3	0	0	1	-1/3	-1/3	2/3
4	1	0	1	1/3	-2/3	1/3
5	1	0	0	2/3	-1/3	-1/3
6	1	1	0	1/3	1/3	-2/3
Null	1	1	1	0	0	0

If the switch A is open-faulted, then the corresponding switching table will be as shown in Table 2. In this case, even though switch A (upper limb) is supposedly turned on, in reality it will remain off, since it has an open-circuit fault.

Table 2: Switching table for the faulted operation in which Switch A is open permanently

STATE #	SWITCH A	SWITCH B	SWITCH C	V_{an} / V	V_{bn} / V	V_{cn} / V
Null	0	0	0	0	0	0
1	0	1	0	-1/3	2/3	-1/3
2	0	1	1	-2/3	1/3	1/3
3	0	0	1	-1/3	-1/3	2/3
4	1	0	1	0	-1/2	1/2
5	1	0	0	0	0	0
6	1	1	0	0	1/2	-1/2
Null	1	1	1	0	0	0

In the previous tables, the symbol V_{an} means voltage between line "A" and the neutral point "n" of the Y winding, and similarly for the other lines. It should also be noted that if there were any remnant current already existing in the winding which was faulted, and if the fault occurred suddenly, then that remnant current will have to continue for a while (since current through the motor winding inductance cannot change abruptly), and it will find a continuity path through either the bottom diode or the top diode of a limb, depending on the direction of the current immediately preceding the fault. Hence, during a brief period, there can be a reverse flow of power from the motor to the battery, depending on the direction of the current which was existing in the circuit at the moment when the fault occurred. However, without a source of regeneration (mechanical regenerative braking etc.) there will not be net a regenerative power in

the steady state, and the current in the faulted winding will not have a resultant regenerative component over a full cycle.

The results corresponding to these are provided in the section 3. In addition to the 6 states shown in the tables (with numbers 1 to 6), where all the states of the switches are not identical, we also have two null states corresponding to all switches being on or off simultaneously. These null states amount to short circuiting of the motor terminals.

It should be noted that in the case of sine triangle PWM scheme, the scheme individually compares the phase voltages a,b,c against some reference, and immediately switches the corresponding switch on or off, if a certain threshold is crossed [8]. This does not take into perspective the situation of the other phases, before making any transition. So, this method, though simple, may not be a good switching strategy in all situations. The consequence of such switching, with switch A faulted, is provided in the section 3.

III. SIMULATION OF FAULTS IN ELECTRICAL DRIVES

This section presents the simulation results of normal and various faulty conditions generated by using the sine triangle PWM, with closed-loop FOC model.

Table 3: The operating conditions used in the sine-PWM-closed-loop model

Variable name	Description	Value
V_{dc}	DC voltage provided by battery	500V
PWM Carrier Frequency	Frequency of the sine wave	8 kHz
Speed	Fixed running speed of the motor	60, 300, 600, 900, 1800 rpm
Reference torque command	Mechanical torque desired from the motor	10, 50, 100, 200 Nm
Simulation time	Simulation Time	6.25s
Trigger Time	Time point to trigger the fault condition	0.25s
Sampling rate	Sampling rate to get the output data.	0.001s
Points of data	Points of data	6000

Figures 3 and 4 show the simulated signals generated under the normal operation condition in a sine-triangle PWM based inverter, using a closed-loop FOC of the induction motor. In Figure 3, the step function is the command torque, and the actual torque is seen to ultimately follow the command with some delay depending on the controller settings.

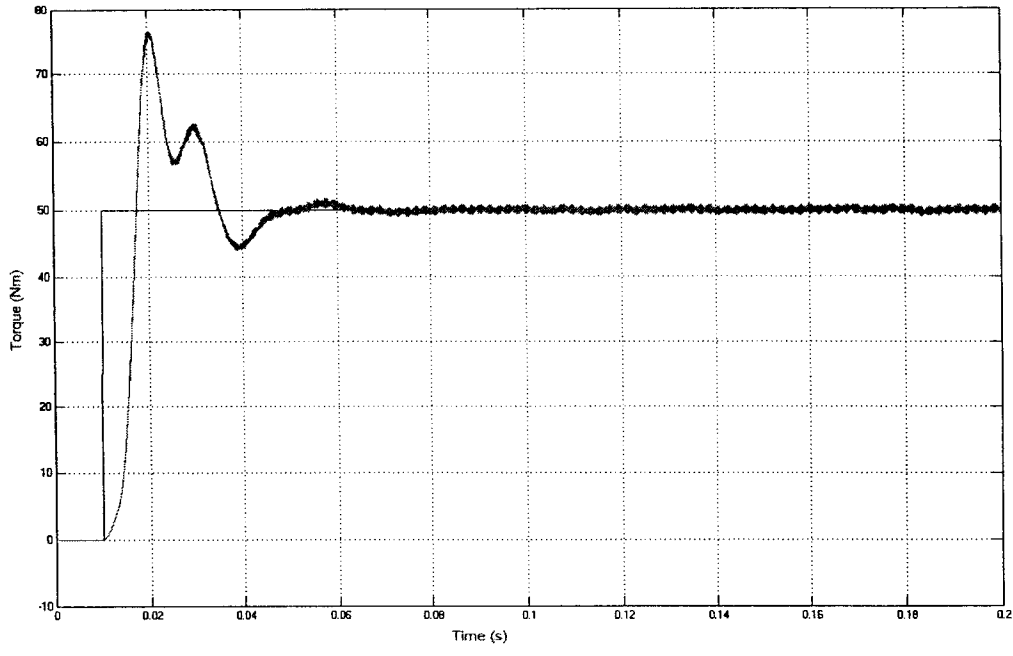

Figure 3. Torque signal in the normal condition in a sine-PWM-closed-loop model

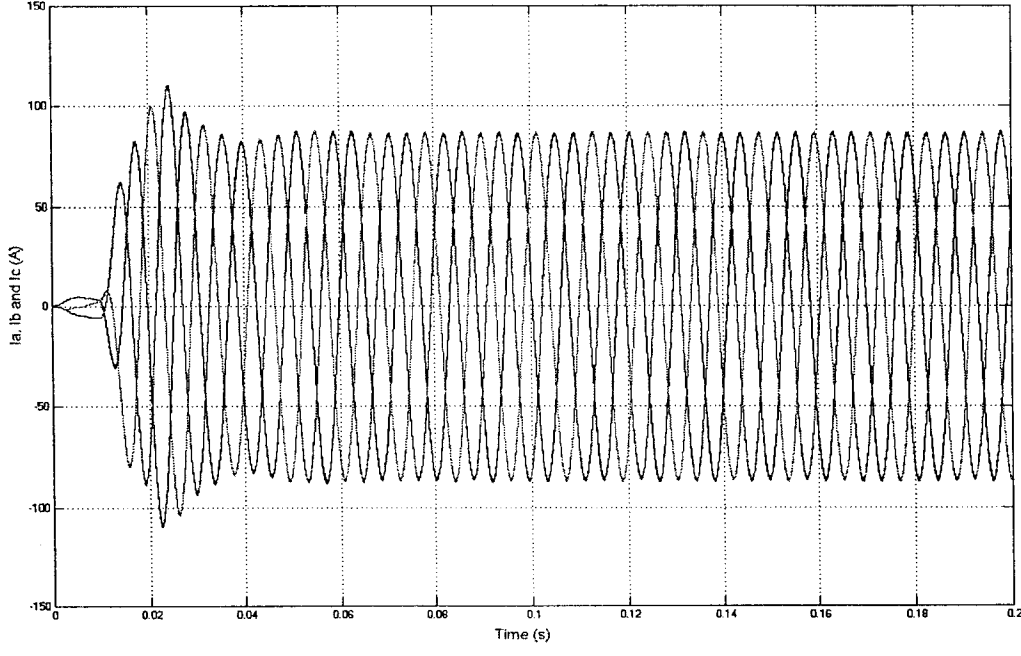

Figure 4. Ia, Ib and Ic (sine-PWM-close-loop model, normal condition)

Figures 5 and 6 show the signal behaviors with the switch A (with reference to Fig. 2) open circuited at time 0.1 secs.

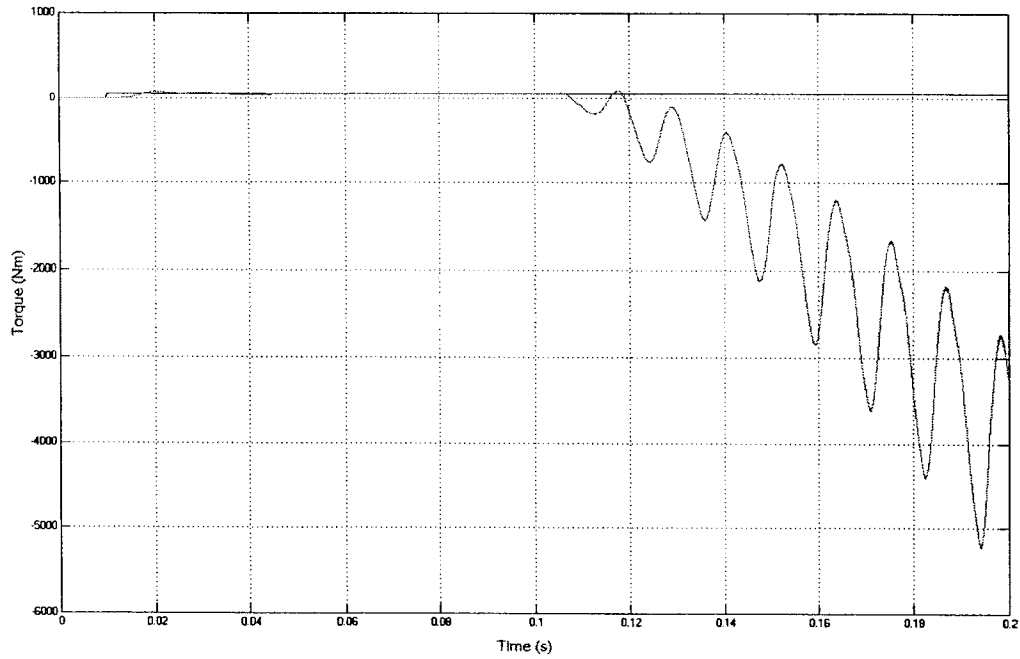

Figure 5. Torque signal with the switch A open condition in a sine-PWM-close-loop model.

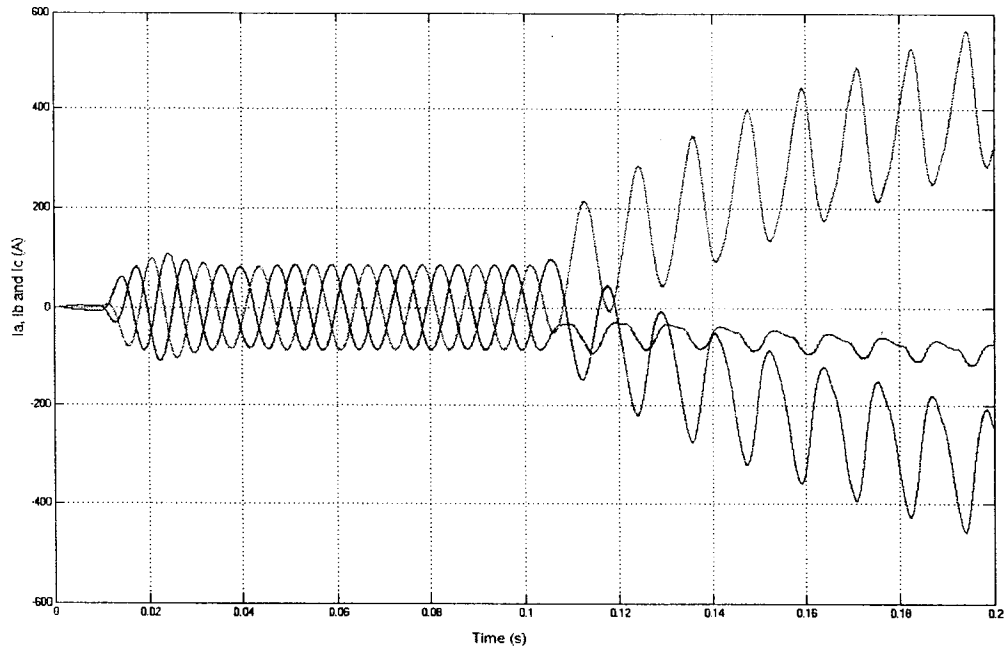

Figure 6. I_a , I_b , I_c signals signal with the switch A open circuited, using a sine-triangle PWM inverter, using closed loop FOC control for the induction motor.

Figures 7 and 8 show the signal behaviors with both switch A and A' (with reference to Figure 2) open circuited at time 0.25 secs. Note that this is the post-short-circuit condition described

earlier, i.e. the effect of short circuiting switch A, since very soon after the short circuit, when A' is gated to be on, there will be a direct short circuit of the source through A and A', leading to a burn out and complete opening of the whole limb consisting of A and A'.

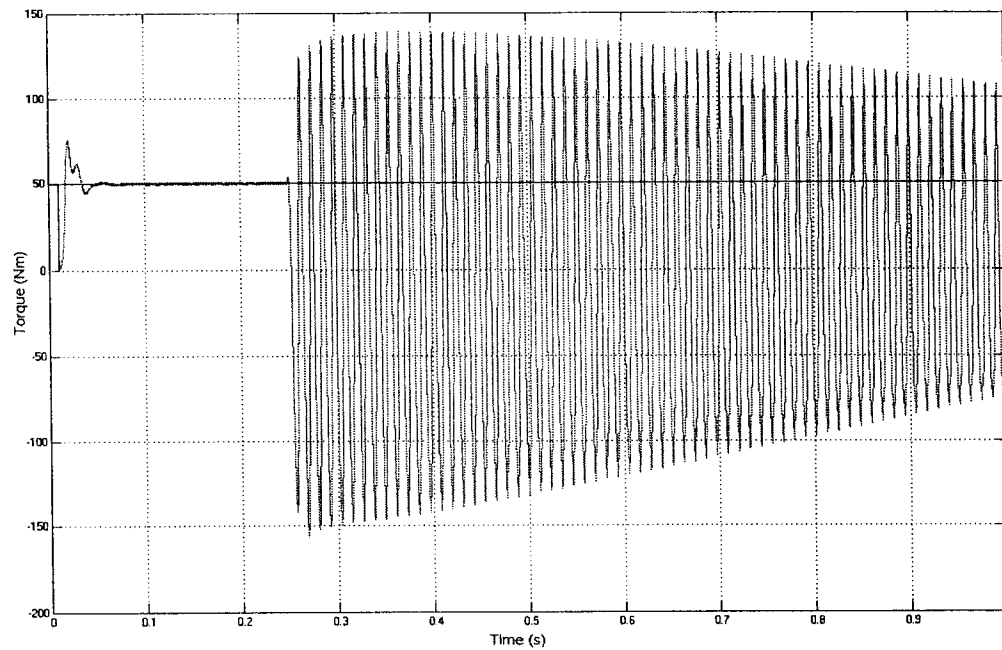

Figure 7. Torque signal with the switch A and A' in open condition in a sine-PWM-closed-loop model.

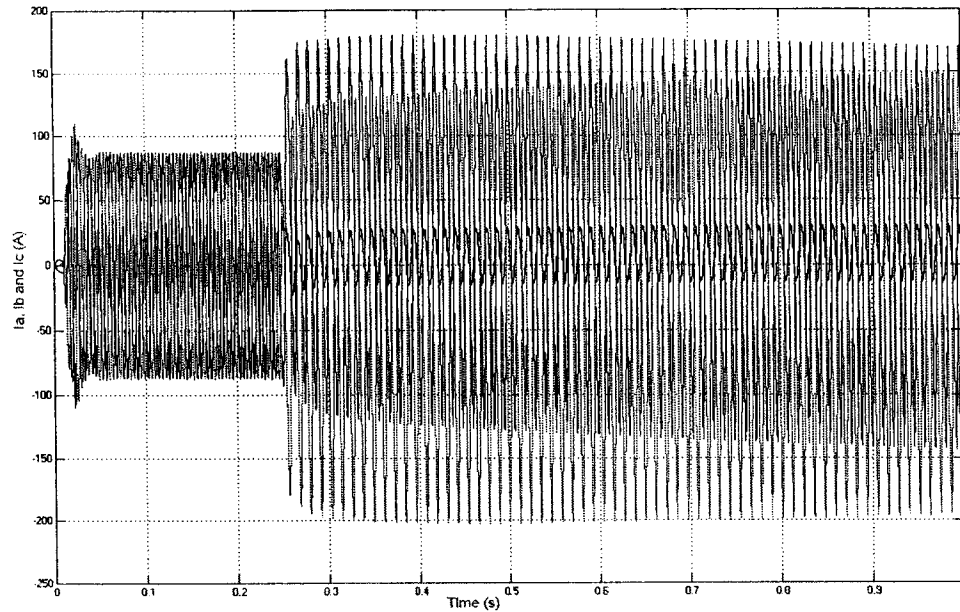

Figure 8. I_a , I_b , I_c signals signal with the switch A and A' open circuited simulated using a sine-triangle PWM inverter with closed loop FOC control for the induction motor.

IV. ELECTRICAL DRIVE FAULT DETECTION USING SIGNAL ANALYSIS AND ARTIFICIAL NEURAL NETWORK

As we have shown in the previous section, the faulty conditions manifest in output signal traces. Fault diagnostics in electrical drive can be performed by developing an intelligent system that has the capability of detecting signal faults under various faulty circuit conditions. The fault diagnostic problem can be modeled as a general classification problem. The input space consists of relevant signals (e.g. voltages and currents among others) from the electrical drive system, and the output space consists of class labels, $\{f_0, f_1, \dots, f_k\}$, where f_0 is considered the normal operational condition, and f_1 through f_k are the k faulty conditions in the electrical drive, which in our case correspond to the 6 switches, one open at a time. Figure 9 illustrates the computational steps involved in our signal fault detection system, where the input consists of the input voltages V_{an} , V_{bn} , V_{cn} to the motor, the currents I_a , I_b , I_c , and the motor electro-magnetic torque T_e . The first computational step is to segment the signals and extract the signal features from each segment. The signal segments are then analyzed by the artificial neural network to determine whether they contain any faults.

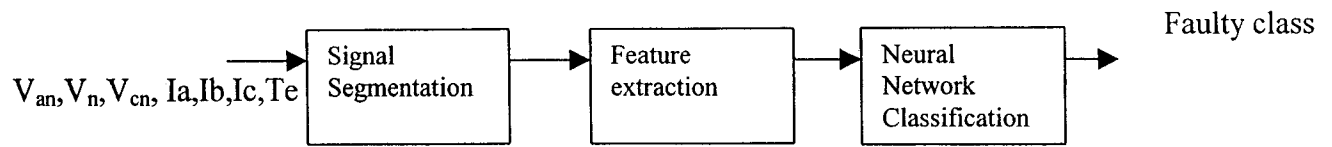

Figure 9. Computational steps in a signal fault detection system.

A. Signal Segmentation and Feature Extraction

Fault detection is performed on a segment-by-segment basis. All input signals are segmented using the same fixed sized segments and the two adjacent segments are overlapped in 1/3 of the segment in order to maintain continuity of information flow between segments. The basic frequency of the signals were over 80 Hz, and sampling frequency is chosen to be 1000, which is sufficient for the purpose. We chose to use 16 samples in each segment, with the overlap of 5 samples between two adjacent segments. For a signal of 3000 data samples, it is segmented into 272 segments. Figure 10 illustrates the segmentation scheme. Each blue line indicates the beginning of a segment, and the first subsequent red line indicates the ending of the previous segment and the second one indicates the ending of the current segment. The signal between a red line and the subsequent blue line is the overlap portion of the two adjacent segments.

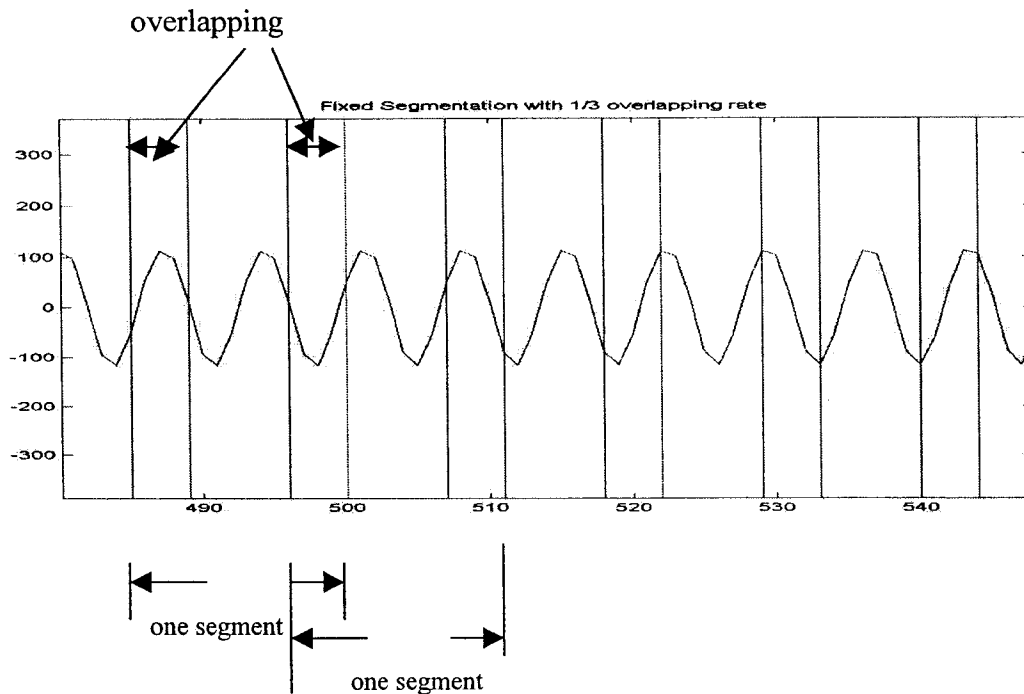

Figure 10. Segments on a signal

Each signal segment is represented by the following features:

Max: Maximum magnitude of the signal within the segment

Min: Minimum magnitude of the signal within the segment

Median: median of the signal within the segment

Mean: mean of the signal within the segment

Standard deviation: standard deviation of the signal segment

Zero-frequency component of the power spectrum

Since we have 7 signals (3 voltage signals, 3 current signals, and 1 torque signal) the detection of signal faults within a time period requires one segment from each signal, and each segment is represented by the 6 features listed above. Therefore, the combined feature vector to represent a particular fault in the electrical drive at a particular time segment is a vector of 42 dimensions. The feature vector is the input to a neural network classifier that detects whether the 7 signals within this time period manifest any fault.

B. Fault Detection using Neural Network

Artificial neural networks are capable of capturing underlying numerical or logical relationships on the basis of training examples. Neural networks have been successfully applied to a broad range of problems including engineering diagnosis, pattern classification, intelligent manufacturing, control problems and computer vision [16-21]. A neural network architecture using feedforward backpropagation consists of the specification of the number of layers, the number of units in each layer, the type of activation function of each unit, and the connection weights between different units, which are determined by a machine learning algorithm. According to Huang et al. [22], two-layer or sometimes called one-hidden layer perceptrons, can implement either convex open or closed decision regions. Therefore, we chose to use a one-hidden-layer architecture for signal fault detection. The number of nodes in the output layer is determined by the number of classes to be classified in an application problem. Most research in neural networks has been focused on binary classifier, which requires one output neuron to indicate to which class the input pattern belongs. We developed a multi-class neural network classifier for object recognition. Most of the research in neural networks has been in the development of learning and training algorithms for binary classifiers, i.e. classifiers with one output node that represent classes 0 and 1. The most common approaches in multi-class neural networks have been to use a group of binary neural networks with a decision rule to integrate the results of neural networks [23-24]. Such approaches require the separated training of each neural network and each trained neural network generates a decision boundary between one class and all others. For classification, an input feature vector is sent to all k neural networks, and a decision module combines the output from all the neural networks to produce the final classification result. A popular decision strategy is implemented by using the methodology known as Winner-Take-All (WTA) [25]. The most noticeable limitation is that the decision boundaries generated by different binary neural network classifiers can overlap or miss regions in the feature space [26]. For the feature vectors that fall into an overlapped region in the feature space, more than one binary classifiers can claim the input as their classes, resulting in ambiguity. For the feature vectors falling into the regions that are not claimed by any neural networks are rejected by all neural networks. As a result the resulting system does not generalize well.

We developed a single neural network system for detecting multi-class signal faults. Figure 11 illustrate the architecture of the system. One important issue in a multi-class neural network classifier is how to encode the classes in the output nodes of the neural network. We choose to use a “one-hot spot” method described as follows. For a k -class classification problem, we need a k -bit output layer, each class is assigned a unique binary string (codeword) of length k . For example if it is a five-class classification problem, class 0 is assigned a codeword of 00001, class 1 is assigned a codeword of 00010, class 2 is assigned of a codeword 00100, etc. The advantage of this encoding is that it gives enough tolerance among different classes. We use the back propagation to train the neural network.

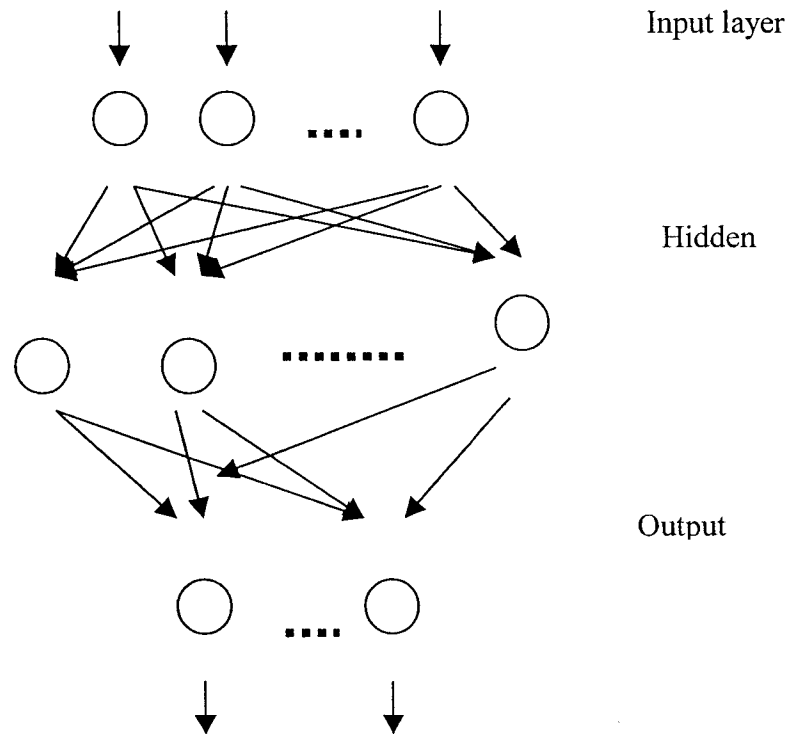

Figure 11: A neural network architecture for multi-fault detection.

C. Experiments

We conducted experiments with data generated from various operating points represented in the speed and torque space. Figure 12 shows the operating condition points used in training and test generated in the speed and torque space (corresponding to Figures 3 to 6). The training data were generated at the points shown in blue color, and test data at the points shown in pink and red colors. At each operation condition point, we ran the simulation for about 6 seconds to

generate seven time series signals, one is normal signal series, and each of the other six series is the result of one of the six switches (see Figure 2) being in open circuit condition. Each signal consists of 6000 samples.

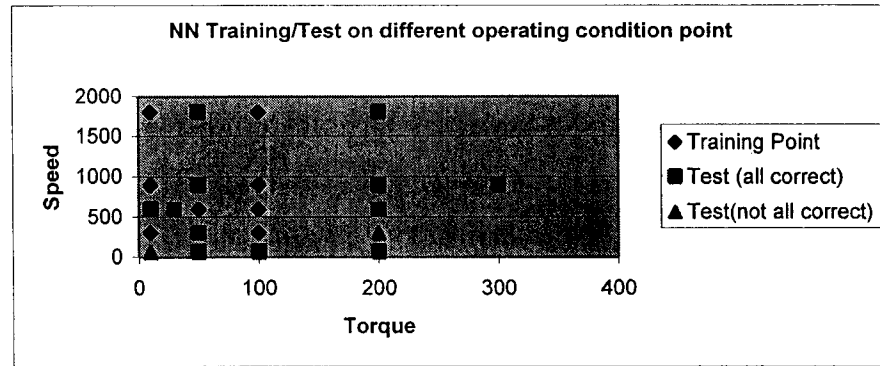

Figure 12. Operation condition points used to generate training and test data for 1-switch broken diagnostics.

We used a neural network architecture of 42 input nodes, 7 output nodes representing the normal case and 6 faulted cases, and 1 hidden layer with 20 hidden nodes. The neural network was trained on the data generated at the 8 operating condition points shown in the blue diamond symbols, and tested on all the points shown in the pink squares and red triangles in Figure 12. The neural network performed with 100% accuracy on all the signals generated at the blue and pink points. A signal is considered 100% correctly classified by the neural network, if all the “normal” segments on the signal are detected by the neural network as “normal”, and all the “faulty” segments on the same signal are detected as the “faulty” class that matches the faulty condition used in data generation. Figure 12 showed that the neural network did not reach 100% on the test data generated at two operating points, (Torque=10, Speed=60) and (Torque=200, Speed=300). The performances of the neural network at these two operating points are shown in Table 5 and 6.

Table 5. Blind Test result at condition
Torque =10 Speed =60

Condition	Correct Rate (%)
Normal	73.90
Fault 1	98.16
Fault 2	97.79
Fault 3	98.53
Fault 4	100
Fault 5	100
Fault 6	100
Total	95.48

Table 6. Blind test result at condition
Torque =200 Speed =300

Condition	Correct Rate (%)
Normal	100
Fault 1	91.18
Fault 2	94.49
Fault 3	100
Fault 4	100
Fault 5	100
Fault 6	74.26
Total	94.28

In both cases, the system performed very well on all classes except one.

The second experiment was conducted on the post-short-circuit cases in the six-switch inverter scheme shown in Figure 2. Three faulty classes were simulated, where each class was generated by making one vertical switch pair open at a time, namely, the pairs A and A', B and B', and C and C' respectively. We used a neural network architecture of 42 input nodes, 4 output nodes representing the normal class and 3 faulted classes, and 1 hidden layer with 20 hidden nodes. The neural network was trained on the data generated at the 8 operating condition points shown in the blue diamond symbols, and was tested on all the points shown in Figure 13, where the pink squares and red triangles represent the operating points at which the test data were generated. The neural network performed with 100% accuracy on all the signals generated at the blue and pink points. Figure 13 also showed that the neural network did not reach accuracy of 100% (but greater than 90%) on the test data generated at two operating points, (Torque=10, Speed=60) and (Torque=50, Speed=60). The performances of the neural network at these two operating points are shown in Table 7 and 8. The neural network performed quite well on all classes.

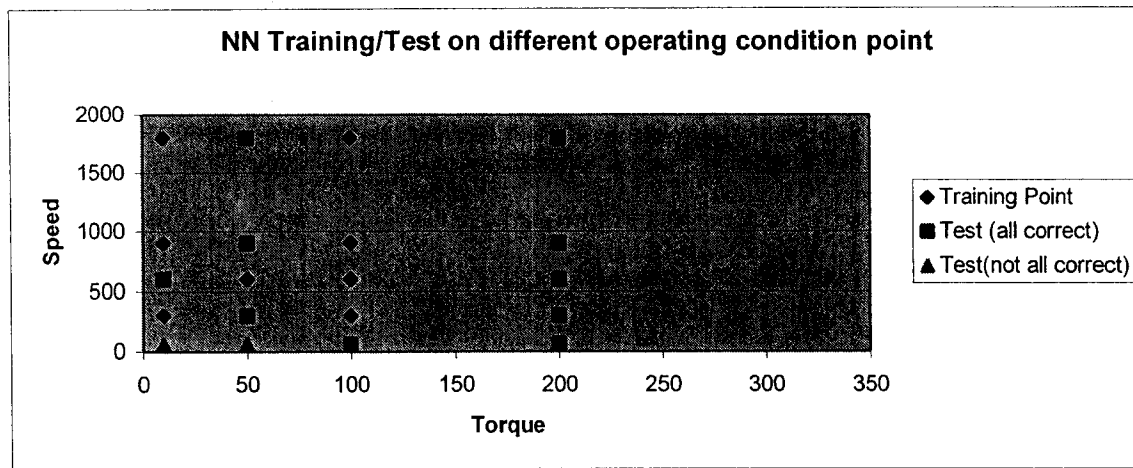

Figure 13. Operation condition points used to generate training and test data for post-short-circuit fault diagnosis.

Table 7. Performance of neural network at Torque =10 Speed =60

Condition	Correct Rate (%)
Normal	100
Fault 1	90.44
Fault 2	100
Fault 3	98.90
Total	97.33

Table 8. Performance of neural network at Torque =50 Speed=60

Condition	Correct Rate (%)
Normal	100
Fault 1	90.44
Fault 2	100
Fault 3	98.90
Total	97.33

V. SUMMARY, DISCUSSION OF RESULTS, AND FUTURE DIRECTIONS

A model based study of the fault diagnosis scheme for an electric drive system using a three phase induction motor has been performed in this work. The first part of the work involved the Matlab-Simulink model of the inverter motor combination, along with its control mechanism under both normal, and faulted conditions. For illustration of the methodology, a closed loop field oriented control was used. We used the sine-triangle PWM method for synthesizing the reference voltage command generated in the FOC. The model was used to capture the signatures of the various sensor quantities under different fault conditions, which are otherwise costly and time consuming, if done experimentally. The simulated sensor signals were segmented and processed offline, and key features were extracted. The extracted features were then processed by an artificial neural network to classify the faults and locate them.

The results indicate that the methodology is very effective in detecting electric drive faults and their location. It is therefore seen that the trained neural network can detect the faults

satisfactorily over a very large portion of the torque-speed domain with very high degree of accuracy. Only at two points, at very low speeds, the results predicted rate were around 75% for the open-circuit fault, and above 90% for the post-short-circuit fault. Although this result is quite good, we intend to find the cause of this and report our findings in our future work. Among other reasons, it may be related to the number of intermediate perceptrons used or the coding scheme used in the output layer, and the training data. In addition, the data segmentation mechanism can influence the results.

In any event, the overall results of the work are very encouraging and imply that the once a neural network has been properly trained, the algorithm can be easily implemented in a real-time automotive system using an inexpensive processor.

The main contribution of this work is as follows. The study of inverter fault diagnostics on electric drives with closed loop control, which has not been traced by the authors in the existing literature, hence this work is an addition to the topic. The closed loop control system tends to change the whole dynamics of the current and voltages during a fault condition, due to the fact that the control system works on the basis of a pre-designed algorithm for dealing with normal operating conditions. Under faulted condition, the controller tries to continuously follow some reference, without success. This leads to continuous raising or lowering of input voltage command to the inverter, until some saturation point is arrived. This makes the diagnostic problem difficult. Open loop systems are relatively easy to deal with, since the controller does not have much role to play in this case during a fault. Secondly, this study has shown that the neural network can successfully identify and locate both open and post-short-circuit faults with a high degree of precision. Post-short-circuit fault studies, which have been done in this work, have also not been traced by the authors in the current literature. Finally, this work has led to a generalized methodology of fault diagnostics, which can be applied under different conditions and for real-time applications, regardless of the nature of the fault, and this is where the authors believe a major merit of the work lies.

Future work - Several items which have not been completed as of now, and are intended for future, are as follows. The authors plan to introduce noise in the simulated data, prior to feeding the data to the neural network. They also plan to extend this model based study further, to cover other subsystems in a vehicular electric power system, namely, the battery, alternator, power management systems, and combine the same with IC engine fault diagnostics scheme, to

get a comprehensive fault-diagnostics methodology for the hybrid electric vehicle and the vehicular electrical power system in general. In addition, future studies will cover the effect of other kind of inverter modulation schemes on the fault diagnostics. Furthermore, it is the intention of the authors to use the results of the findings here to devise possible automatic reconfiguration of the electrical system architecture in order to lead to a graceful system degradation, which can avoid complete and, sometimes, catastrophic failures. Finally, the authors also intend to study the effect of using multiple neural networks to diagnose various subsystems and then combine the results for the whole system diagnostics, as opposed to a single neural network to capture the complete system fault diagnostics, in terms of accuracy, number of perceptrons, and hidden layers needed.

ACKNOWLEDGMENT

The research described in this paper was made possible through a funding by the US Army RDECOM ILIR (In-house Laboratory Independent Research) program, which was made available to the principal investigator. The authors sincerely appreciate this support. The authors also specifically wish to thank Dr. Grant Gerhart, Senior Research Scientist at US Army RDECOM-TARDEC, and Dr. Walter Bryzik, Chief Scientist at US Army RDECOM-TARDEC, for approving the project and the funding, and to Dr. Rob Karlsen, RDECOM-TARDEC, for providing necessary administrative support for the work.

REFERENCES

- [1] C. Chan and K.T. Chau, "*Modern electric vehicle technology*", Oxford University Press, 2001.
- [2] R. Hodkinson and J. Fenton, "*Lightweight electric/hybrid vehicle design*", SAE International, 2001. Warrendale, PA, USA.
- [3] D. W. Novotny and T. A. Lipo, "*Vector control and dynamics of AC drives*", Oxford Sc. Pub., 1996.
- [4] A. Bakhshai, G. Joos, J. Espinoza, H. Jin, "Fast pace vector modulation based on a neurocomputing digital signal processor", *Applied Power Electronics Conference and Exposition*, 1997, Vol. 12, pp 872-878.
- [5] N. Mohan, T. Undeland, and W. Robbins, "*Power Electronics*", John Wiley, 1995.
- [6] N. Y. Kao and C. Liu, "Analysis and design of microprocessor-based vector-controlled induction motor drives", *IEEE Trans. on Ind. Electronics*, Vol 39., No. 1, Feb. 1992, pp. 46-54.
- [7] C. Liaw, K. Chao, and F. Lin, "A discrete adaptive field-oriented induction motor drive", *IEEE Trans. on Power Electronics*, Vol. 7, No. 2, Apr. 1992, pp. 411-419.
- [8] J. Holtz, "Pulse width modulation – a survey", *IEEE Transactions on Industrial Electronics*, Vol. 39, No. 5, Dec. 1992, pp. 411-420.
- [9] M.A. Masrur, X. Xu, and F. Liang, "Fault Isolation in an Induction Motor Control System", *U.S. Patent 5469351*, Nov 1995.
- [10] J. Klima, "Analytical investigation of an induction motor drive under inverter fault mode operations", *IEE Proc.- Electr. Power Appl.*, Vol 150, No. 3, May 2003, pp. 255-262.

- [11] J. Gertler, M. Costin, X. Fang, Z. Kowalczyk, M. Kunwer, R. Monajemy, "Model Based Diagnosis for Automotive Engines-Algorithm Development and Testing on a production Vehicle", *IEEE Trans on Control Systems Technology*, Vol. 3, No. 1, 1995.
- [12] M. Nyberg, "Model-based Diagnosis of an Automotive Engine Using Several Types of Fault Models", *IEEE Transaction on Control Systems Technology*, Vol. 10, No. 5, pp 679-689, 2002.
- [13] O. Moseler, R. Isermann, "Application of Model-Based Fault Detection to a Brushless DC Motor", *IEEE Trans on Industrial Electronics*, Vol. 47, No. 5, pp 1015-1020, 2000.
- [14] R. Ribeiro, C. B. Jacobina, E. Silva, "Fault Detection of Open-Switch Damage in Voltage-Fed PWM Motor Drive System", *IEEE Trans on Power Electronics*, Vol. 18, No. 2, March 2003, pp 587-593.
- [15] W. Fenton, T. McGinnity, and L. Maguire, "Fault diagnosis of electronic systems using intelligent techniques: a review", *IEEE Trans. on Systems, Man, and Cybernetics – Pt. C*, Vol. 31, No. 3, Aug 2000, pp. 269-281.
- [16] C. H. Dagli, "Artificial Neural Networks for Intelligent Manufacturing", Chapman and Hal, 1994.
- [17] Christopher M. Bishop, *Neural Networks for Pattern Recognition*, Oxford University Press, 1995.
- [18] Y. LeCun, L. Bottou, and Y. Bengio and P. Haffner, "Gradient-Based Learning Applied to Document Recognition," *Proceedings of the IEEE*, (86) 11, pp. 2278-2324, 1998.
- [19] L. A. Feldkamp and G. V. Puskorius, "A Signal Processing Framework Based on Dynamic Neural Networks with Application to Problems in Adaptation, Filtering, and Classification," *Proceedings of The IEEE*, Vol. 86, No. 11, November, 1998.
- [20] K. Fukushima, "A Neural Network for Visual pattern Recognition", *IEEE Computers*, March 1998.
- [21] Zhao, L.; Thorpe, E., "Stereo- and neural network-based pedestrian detection," *IEEE Transactions on Intelligent Transportation Systems*, Volume: 1, Issue: 3 , Sept. 2000, Page(s): 148 –154.
- [22] W. Y. Huang, and R.P. Lippmann, "Neural net and traditional classifiers". in D. Z. Anderson (Ed.), *Neural Information Processing Systems*, pp. 387-396. New York: American Institute of Physics.
- [23] E.L. Allwein, R.E. Schapire, "Reducing Multiclass to Binary: A Unifying Approach for Margin Classifiers," *Journal of Machine Learning Research 1*, pp. 113-141, 2000.
- [24] D. Price, S. Knerr, "Pairwise Neural Network Classifiers with Probabilistic Outputs," *Neural Information Processing Systems*, vol. 7, 1994.
- [25] S. Har-Peled, Roth, and D. Zimak. "Constraint classification: A new approach to multiclass classification", in *Proc. 13th International Conf. of Algorithmic Learning Theory*, pages 365–397, 2002.
- [26] Tie Qi Chen, Yi L. Murphey, Robert Karlsen, and Grant Gerhart, "Classification of Objects in Outdoor Scenes," submitted to the *Journal of Pattern Recognition*, Oct. 2003.