

Logistics and Capability Implications of a Bradley Fighting Vehicle with a Fuel Cell Auxiliary Power Unit

Joseph Conover, Harry Husted, John MacBain
Delphi Corporation

Heather McKee
US Army TACOM

Copyright © 2003 SAE International

ABSTRACT

Modern military ground vehicles are dependent not only on armor and munitions, but also on their electronic equipment. Advances in battlefield sensing, targeting, and communications devices have resulted in military vehicles with a wide array of electrical and electronic loads requiring power. These vehicles are typically designed to supply this power via a main internal combustion engine outfitted with a generator. Batteries are also incorporated to allow power to be supplied for a limited time when the engine is off. It is desirable to use a subset of the battlefield electronics in the vehicle while the engine is off, in a mode called "silent watch." Operating time in this mode is limited, however, by battery capacity unless an auxiliary power unit (APU) is used or the main engines are restarted. Integration of a solid oxide fuel cell (SOFC) auxiliary power unit into a military vehicle has the potential to greatly extend silent watch operating time and capabilities while significantly reducing fuel use.

In this paper the results of a study are presented which show the fuel usage and capability impacts of incorporating a fuel cell APU into the electrical system of a Bradley M2A3 Diesel Infantry Fighting Vehicle. Several APU sizes are presented with varying levels of electrical equipment and engine-off capability. Complete off-loading of engine-driven accessories is also studied as a scenario with the resulting impact on available engine power presented. The silent watch operating scenario shows an 86% reduction in fuel use. With fuel costing several hundred dollars per gallon as deployed on the battlefield, such a reduction is valuable. Furthermore, the SOFC APU offers 36 days of continuous silent watch using the same JP-8 fuel tank as the M2A3 without the need for a secondary fuel supply.

INTRODUCTION

US military land vehicle engines are designed to maximize power output while not necessarily optimizing

fuel economy. This has been an acceptable norm for decades. It is commonly understood that water and fuel are the two biggest logistics concerns on the battlefield. As General Paul Kern, of the U.S. Army, stated at the 2003 SAE World Congress, 2/3 of the Army's vehicles deliver fuel to the other 1/3 in the battlefield, with 65% of the fuel consumed in the battlefield theater used to transport fuel to the battlefield. This is an unacceptable logistical situation and an enormous financial burden to the US Army. One option to address the fuel logistics issue is through the utilization of fuel cells. [1]

Fuel cells have the potential of having improved fuel efficiency over traditional internal combustion engines (ICE), as well as lower heat rejection, reduced emissions, and vibration/noise reduction. [2,3] One of the most important operations in a battlefield is what is called "silent watch," which means military forces are waiting to engage and/or move in the theater. A substantial percentage of time is devoted to waiting in these stationary vehicles, with an idling engine, while maintaining readiness. Engines are not optimized to run at idle and are fuel inefficient at this point.

To study one potential source of improvement, a powertrain model was developed to determine the logistics and sustainability implications of integrating a fuel cell APU into a Bradley M2A3 Diesel Infantry Fighting Vehicle. Two applications were studied with the powertrain model: (1) electrical supply for silent watch operation, and (2) off-loading engine accessories which are then powered electrically by a fuel cell. These applications are further described below.

APPLICATION 1: SILENT WATCH ELECTRICITY

Silent watch mode is characterized by giving the M2A3 the ability to be on the alert and actively monitoring the battlefield without the main engine running (hence the term silent). During silent watch mode in today's vehicle the diesel engine is off and all electronic equipment is powered by batteries. The engine remains off until the batteries reach the minimum capacity necessary to

Report Documentation Page

Form Approved
OMB No. 0704-0188

Public reporting burden for the collection of information is estimated to average 1 hour per response, including the time for reviewing instructions, searching existing data sources, gathering and maintaining the data needed, and completing and reviewing the collection of information. Send comments regarding this burden estimate or any other aspect of this collection of information, including suggestions for reducing this burden, to Washington Headquarters Services, Directorate for Information Operations and Reports, 1215 Jefferson Davis Highway, Suite 1204, Arlington VA 22202-4302. Respondents should be aware that notwithstanding any other provision of law, no person shall be subject to a penalty for failing to comply with a collection of information if it does not display a currently valid OMB control number.

1. REPORT DATE

13 OCT 2003

2. REPORT TYPE

Journal Article

3. DATES COVERED

12-09-2003 to 12-10-2003

4. TITLE AND SUBTITLE

Logistics and Capability Implications of a Bradley Fighting Vehicle with a Fuel Cell Auxiliary Power Unit

5a. CONTRACT NUMBER

5b. GRANT NUMBER

5c. PROGRAM ELEMENT NUMBER

6. AUTHOR(S)

Joseph Conover; Harry Husted; John MacBain; Heather McKee

5d. PROJECT NUMBER

5e. TASK NUMBER

5f. WORK UNIT NUMBER

7. PERFORMING ORGANIZATION NAME(S) AND ADDRESS(ES)

Delphi Corporation, 5725 Delphi Drive, Troy, Mi, 48098

8. PERFORMING ORGANIZATION REPORT NUMBER

; #13956

9. SPONSORING/MONITORING AGENCY NAME(S) AND ADDRESS(ES)

U.S. Army TARDEC, 6501 East Eleven Mile Rd, Warren, Mi, 48397-5000

10. SPONSOR/MONITOR'S ACRONYM(S)

TARDEC

11. SPONSOR/MONITOR'S REPORT NUMBER(S)

#13956

12. DISTRIBUTION/AVAILABILITY STATEMENT

Approved for public release; distribution unlimited

13. SUPPLEMENTARY NOTES

14. ABSTRACT

Modern military ground vehicles are dependent not only on armor and munitions, but also on their electronic equipment. Advances in battlefield sensing, targeting, and communications devices have resulted in military vehicles with a wide array of electrical and electronic loads requiring power. These vehicles are typically designed to supply this power via a main internal combustion engine outfitted with a generator. Batteries are also incorporated to allow power to be supplied for a limited time when the engine is off. It is desirable to use a subset of the battlefield electronics in the vehicle while the engine is off, in a mode called ?silent watch.? Operating time in this mode is limited, however, by battery capacity unless an auxiliary power unit (APU) is used or the main engines are restarted. Integration of a solid oxide fuel cell (SOFC) auxiliary power unit into a military vehicle has the potential to greatly extend silent watch operating time and capabilities while significantly reducing fuel use. In this paper the results of a study are presented which show the fuel usage and capability impacts of incorporating a fuel cell APU into the electrical system of a Bradley M2A3 Diesel Infantry Fighting Vehicle. Several APU sizes are presented with varying levels of electrical equipment and engine-off capability. Complete off-loading of engine-driven accessories is also studied as a scenario with the resulting impact on available engine power presented. The silent watch operating scenario shows an 86% reduction in fuel use. With fuel costing several hundred dollars per gallon as deployed on the battlefield, such a reduction is valuable. Furthermore, the SOFC APU offers 36 days of continuous silent watch using the same JP-8 fuel tank as the M2A3 without the need for a secondary fuel supply.

15. SUBJECT TERMS

16. SECURITY CLASSIFICATION OF:			17. LIMITATION OF ABSTRACT Public Release	18. NUMBER OF PAGES 9	19a. NAME OF RESPONSIBLE PERSON
a. REPORT unclassified	b. ABSTRACT unclassified	c. THIS PAGE unclassified			

Standard Form 298 (Rev. 8-98)
Prescribed by ANSI Std Z39-18

restart the engine. In typical operation, silent watch is interrupted periodically to restart the engine to recharge the batteries.

If a fuel cell APU could be used to supply the silent watch electrical loads, the batteries would remain charged and much longer engine-off times during silent watch would be possible. The benefits of using a fuel cell APU in this scenario could be fuel savings, acoustic and thermal signature reduction, and a much longer silent watch period.

APPLICATION 2: ENGINE ACCESSORIES

The second fuel cell concept studied an M2A3 where all engine driven accessory loads are completely removed from the engine and electrically-driven accessories are substituted and powered by a fuel cell. The engine accessories are currently mechanically driven from the engine crankshaft and are strictly on/off (not modulated). Thus they are only optimized for one speed/torque combination. Therefore, military vehicles are operating for a substantial period of time at a less efficient operating condition with accessories that are not optimized. A reduction in heat rejection, tailpipe emissions, and noise could help reduce identification signature of the vehicle by the enemy in the battlefield. As an auxiliary power unit, a fuel cell could power these accessories as well as other load requirements on the vehicle, while optimizing the entire system, all while reducing the identification signature.

To determine the performance and fuel logistics benefits of this second application, the following parameters were modeled:

- Improvement in peak engine power available for motive power
- Improvement in vehicle acceleration from 0 to 30 mph assuming constant acceleration
- Additional motive power available for maximum speed
- Fuel economy impact with the engine operating point at maximum RPM and 75% of full power, under three electrical load conditions: 140 A (minimum operational), 250 A (average operational), and 360 A (maximum operational).

BRADLEY VEHICLE OVERVIEW

The Bradley family of tracked and armored vehicles has several variants to carry out specific missions. The Bradley Diesel Infantry Fighting Vehicle (IFV), designated M2A3, is one of the most common variants of the Bradley family. Many of the older M2A2 variants have been upgraded to the superior M2A3 variant. The main mission of the IFV is to carry troops into and out of the battlefield in a protected environment while providing fire support and reconnaissance when necessary. The M2A3 carries a crew of three (commander, driver, and gunner) and up to six infantrymen.

BRADLEY POWERTRAIN

Figure 1 shows a simple diagram of the M2A3 powertrain. A Cummins 447kW (600 hp) diesel engine propels the vehicle. The engine is fueled by JP-8¹ in the battlefield, but in a non-battle situation can run on diesel if necessary with only a fuel injector hardware change. A single, 28V, 400A permanent-magnet direct current (DC) generator is driven by a power take off (PTO) directly connected to the engine. The hull fan is connected to the engine by a PTO shaft and a torque coupler. The hull fan operates continuously when the engine is on to provide air cooling to the engine compartment and hull of the vehicle. A water pump is also belt-driven by the engine.

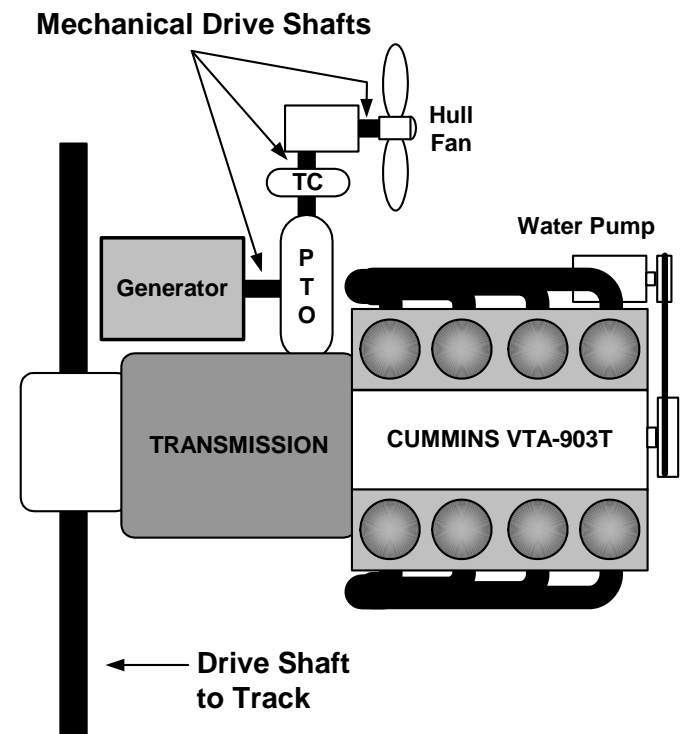

Figure 1: Simplified M2A3 Powertrain Diagram

TACOM provided performance data on the Cummins VTA-903T engine. The data was used to build an engine fuel use model based on the fuel consumption and power output. A four-hour field test verified the idle fuel rate, since this rate was not in the performance data. The idle fuel rate correlated well with published information for similar-sized diesel engines in Class 8 long-haul diesel trucks. [4]

¹ JP-8 has been identified as the single fuel for the battlefield. It is a kerosene-type aviation turbine fuel with additional additives and is a suitable replacement for diesel fuel.

IFV ELECTRICAL SYSTEM

A simplified electrical diagram for the M2A3 is shown in Figure 2. The electrical system has a nominal operating voltage of 28 volts and is supplied power from a 400A generator driven by the main engine. A total of seven batteries are used in the vehicle. The main battery tray is in the floor of the vehicle and consists of four 12V, 120Ah lead-acid batteries arranged in two parallel strings of two batteries in series. An auxiliary tray of two 12V, 120Ah lead-acid batteries in series is mounted in a drawer on the left side of the vehicle. Finally, a single 24V lead-acid battery is in the floor of the turret.

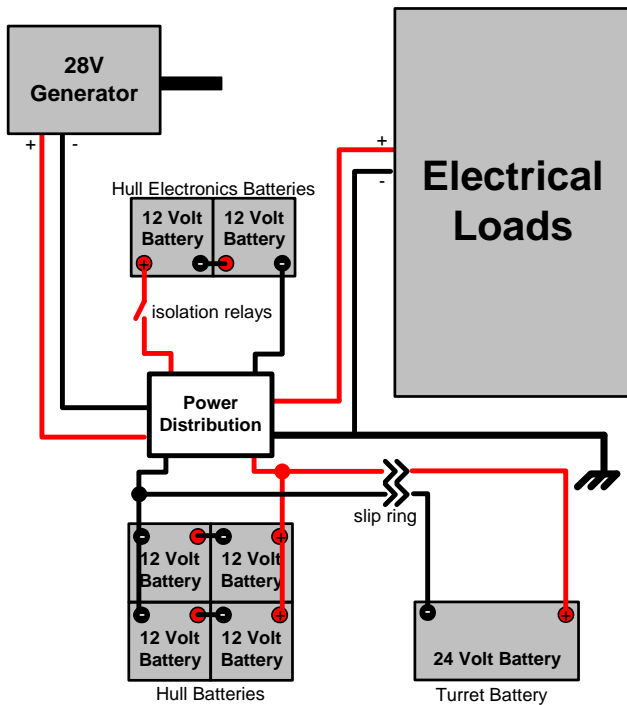

Figure 2: Simplified IFV Electrical Schematic

A simple generator model was created using the manufacturer's product specification sheets. Data for the IFV generator was not available, so generator data for the Bradley Command Vehicle was used instead. Both generators are 28V with 400A maximum output. The model calculated the mechanical shaft power required from the engine as the product of required electrical power multiplied by the generator efficiency and the PTO shaft efficiency. For the study, all PTO shaft efficiencies were 98 percent.

M2A3 ELECTRICAL LOADS

United Defense (UD) provided a detailed spreadsheet which shows the electrical current required by each of the dozens of electrical devices in the M2A3. The load spreadsheet provides a matrix showing how these loads vary with temperature and operating mode. The devices are further grouped into seven electrical operational

scenarios that are referred to as "load scenarios" and are summarized in Table 1 below. Note that the electrical loads shown in Table 1 are for a stationary vehicle. A more detailed definition of the M2A3 loads can be found in the appendix.

Scenario Number	Description	Electrical Load (Amperes)
1	Normal Operation	135
2	Silent Watch	83
3	#1 + Water Crossing	175
4	#1 + Combat: Turret & Gun	160
5	#4 + MCD, BELRF	182
6	#5 + NBC	273
7	#6 + MCS	285

Table 1: Electrical Load Scenarios – Stationary Vehicle

ENHANCED SILENT WATCH

An additional load scenario called "Enhanced silent watch" was created and analyzed during the study. This scenario is defined as the normal silent watch load plus and additional 25 A for gun turret and TOW movement (or other key functions for a stationary vehicle). Enhanced silent watch loads for a stationary vehicle are 108 A.

SOFC APU OVERVIEW

The study used the projected future performance of a next-generation Delphi solid oxide fuel cell (SOFC) power unit with an integral JP-8 reformer. A solid oxide fuel cell is well-suited to liquid hydrocarbon fuels such as JP-8 because it is a high temperature fuel cell and it is capable of using carbon monoxide (CO) as a fuel. This allows the use of a compact, high temperature reformer without the need for the CO cleanup steps associated with a proton exchange membrane (PEM) fuel cell. Figure 3 shows the SOFC APU currently under development. [5] A standard automotive battery is shown next to the APU as a size reference.



Figure 3: Delphi Next Generation SOFC APU

Table 2 shows the efficiency and fuel use projections, which are based on a 5 kW SOFC APU being developed under the Solid State Energy Conversion Alliance (SECA) program.

The overall SOFC system efficiency is calculated using the lower heating value (LHV) of fuel (42.8 MJ/kg for JP-8 fuel according to MIL-DTL-83133E). Note that the SOFC APU has an on-board reformer unit. Thus, the data shown in Table 2 include the JP-8 on-board reformation process and reflect the total fuel input to electrical output efficiency.

When a larger APU was needed for the purposes of this study, it was decided to scale the APU efficiency and fuel use linearly as shown in Table 2. This table is used throughout the model to determine APU fuel consumption and APU efficiencies. The model determines the appropriate SOFC size and interpolates within the range of values to find the corresponding fuel rate and efficiency. For example, if the required APU

electrical output is 57 kW, the cell formula will use the 60 kW SOFC values and interpolate accordingly to find the fuel use.

MODELING – SILENT WATCH

The silent watch analysis compared an M2A3 with an idling engine driving a generator (the “baseline”) to an M2A3 operating a fuel cell APU with the engine off. In both cases, it is assumed that the vehicle operates on battery for a certain period of time, after which, the engine or APU will start in order to prevent the batteries from discharging further. The engine and generator or the fuel cell APU provide the electricity thereafter. The key assumption for the simulation results is that the M2A3 has reached the point where the engine must run to recharge the batteries. Thus, we can directly compare the fuel rates for the baseline M2A3 and the fuel cell APU.

Table 3 lists several other vehicle level assumptions that are common throughout the study. The 25% value of idle engine efficiency is a conservative estimate based on Delphi and TACOM's experience. Also, the model allows the user to enter an electrical power overrating factor. This gives the user a simple way of scaling up or down the electrical demand if desired.

Engine Efficiency at Idle	25%
Over-Rating Multiplication Factor (ORF)	1.0
Generator PTO Efficiency	98%
Hull fan PTO Efficiency	98%
Operating Voltage	28V

Table 3: Vehicle Level Simulation Assumptions

To perform a fuel usage comparison of the idling engine with the fuel cell APU, the fuel consumption for the M2A3 as it is equipped today must be determined. The total baseline idle fuel rate for the M2A3 is the sum of

5 kW SOFC		10 kW SOFC (2X 5kW)		20 kW SOFC (4X 5kW)		40 kW SOFC (8X 5kW)		60 kW SOFC (12X 5kW)		System Efficiency With Reformer
Net Power (kW)	Fuel rate (g/s)	Net Power (kW)	Fuel rate (g/s)	Net Power (kW)	Fuel rate (g/s)	Net Power (kW)	Fuel rate (g/s)	Net Power (kW)	Fuel rate (g/s)	
0.1	0.075	0.2	0.150	0.4	0.299	0.8	0.60	1.2	0.897	3.1%
0.5	0.086	1.0	0.173	2.0	0.346	4.0	0.69	6.0	1.037	13.5%
1.0	0.100	2.0	0.201	4.0	0.402	8.0	0.80	12.0	1.206	23.3%
1.5	0.114	3.0	0.229	6.0	0.458	12.0	0.92	18.0	1.374	30.6%
2.0	0.131	4.0	0.262	8.0	0.523	16.0	1.05	24.0	1.570	35.7%
2.5	0.152	5.0	0.304	10.0	0.607	20.0	1.21	30.0	1.822	38.5%
3.0	0.175	6.0	0.350	12.0	0.701	24.0	1.40	36.0	2.103	40.0%
3.5	0.199	7.0	0.397	14.0	0.794	28.0	1.59	42.0	2.383	41.2%
4.0	0.227	8.0	0.453	16.0	0.907	32.0	1.81	48.0	2.720	41.2%
4.5	0.262	9.0	0.523	18.0	1.047	36.0	2.09	54.0	3.140	40.2%
5.0	0.299	10.0	0.598	20.0	1.196	40.0	2.39	60.0	3.589	39.1%

Table 2: SOFC Fuel Use and Efficiency

UD Load Scenario	Electrical Load Scenarios - Stationary Vehicle	Required Electrical Power (kW)	Generator Mechanical Power (kW)	Hull Fan and Water Pump Mechanical Power at Idle (kW)	Total Power at Engine Shaft (kW)
2	Silent	2.3	3.0	2.1	5.2
	Enhanced Silent: Silent Watch + Turret & Gun Loads	3.0	3.9	2.1	6.1
1	Normal Operation (i.e.- Idle Loads)	3.8	5.0	2.1	7.1
3	Water Crossing (i.e. bilge pump) - Idle Loads	4.9	6.4	2.1	8.6
4	Combat: Turret & Gun & Idle Loads	4.5	5.9	2.1	8.0
5	Combat: Turret, Gun, MCD, BELRF & Idle Loads	5.1	6.7	2.1	8.9
6	Combat: Turret, Gun, MCD, BELRF, NBC & Idle Loads	7.6	10.0	2.1	12.2
7	Combat: Turret, Gun, MCD, BELRF, NBC, MCS & Idle Loads	8.0	10.5	2.1	12.6

Table 4: Engine Power Needed to Operate Mechanical Accessories

UD Load Scenario	Electrical Load Scenarios - Stationary Vehicle	Electrical Load (Amps)	Required SOFC APU Power (kW)	Percent Improved over Idling Engine
2	Silent Watch	83	2.3	86%
	Enhanced Silent Watch: Silent Watch + Turret & Gun Loads	108	3.0	85%
1	Normal Operation (i.e.- Idle Loads)	135	3.8	83%
3	Water Crossing (i.e. bilge pump) - Idle Loads	175	4.9	79%
4	Combat: Turret & Gun & Idle Loads	160	4.5	80%
5	Combat: Turret, Gun, MCD, BELRF & Idle Loads	182	5.1	78%
6	Combat: Turret, Gun, MCD, BELRF, NBC & Idle Loads	273	7.6	75%
7	Combat: Turret, Gun, MCD, BELRF, NBC, MCS & Idle Loads	285	8.0	74%

Table 5: Application 1: APU Electrical Sizing Per Load Scenario and Fuel Savings of SOFC-APU vs. Idling Engine for a Stationary Vehicle

the no-load engine idle rate and the incremental fuel rate for the engine-driven accessory loads. The no load fuel rate was obtained from the vehicle manufacturer (United Defense). The no-load engine idle fuel rate represents the engine idle fuel rate without added accessory loads, such as the generator and hull fan. Therefore, the engine must use some incremental amount of fuel above the no-load rate to power accessories. This incremental fuel rate is calculated based on the power required to operate the accessory devices and the efficiencies of the device and the PTO shaft connecting the device to the engine. Table 4 summarizes the incremental power necessary to operate the mechanical accessories at idle.

Using the LHV of the fuel and the incremental power value from Table 4, the incremental fuel consumed to power the mechanical accessories can be calculated.

RESULTS – SILENT WATCH

Table 5 shows the electrical load needed to operate the M2A3 in silent watch mode and the other load scenarios. Assuming that the batteries are charge neutral within the system, the fuel cell APU must supply the entire electrical load. Therefore, the electrical sizing for a fuel cell in the M2A3 will equal the electrical power demand. For example, a 2.3 kW fuel cell APU will be sufficient for silent watch loads. A 3.0 kW fuel cell APU would enable all silent watch loads plus turret and gun movement.

Note that additional power would be required if the fuel cell APU needed to charge the vehicle batteries while also supplying the electrical loads in question. This additional power can be approximately calculated by determining the depth of discharge of the batteries and the desired charging time. For example, if the six main hull batteries are to be charged from 50% to 100% state of charge in eight hours, then $(360\text{Ahr} \times 0.5 \text{ of total capacity}) / (8 \text{ hours of charge})$ means that 22.5A is required. At 28V, this represents an additional load of 630 watts. Thus, an APU sized for silent watch plus battery charging as described would need to be sized for $2.3\text{kW} + 0.63\text{kW} = 2.93\text{kW}$

Table 5 also shows the final results for fuel savings for silent watch operations. For completeness, various modes of operation requiring higher electrical output and thus APU size are presented. It is clear that the M2A3 main engine and generator uses significantly more fuel than would an M2A3 with an SOFC APU to power the electrical loads.

Figure 4 shows that an M2A3 equipped with a SOFC APU used for various load scenarios can substantially increase the number of days that the crew can operate in silent watch mode. The SOFC APU enables up to 36 days of continuous silent watch operation using the main JP-8 fuel tank versus five days from idling the main engine.

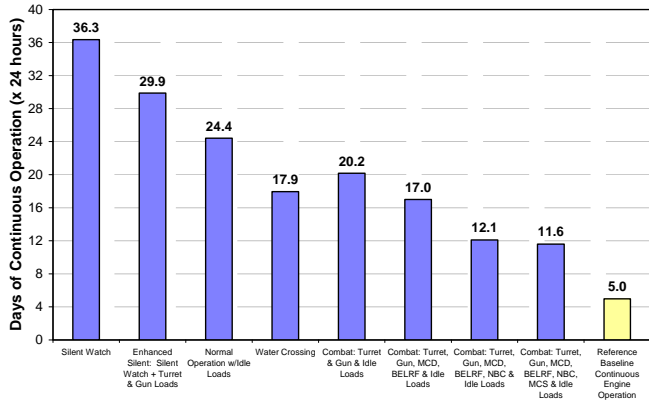

Figure 4 Operating Duration by Load Scenario (Electrical Power from SOFC APU; Engine Off, 150 gallon M2A3 Main Fuel Tank)

MODELING - ENGINE ACCESSORIES

To determine the needed electrical power output of a fuel cell APU to power all the engine accessories, a model was created to calculate the shaft power needed by the hull fan and water pump and then determine how much power would be required to drive these devices electrically. To these two values, the electrical generating requirement is added to arrive at a total electrical power output.

Models for the hull fan (also called the engine cooling fan) and the water pump were obtained from models in the ADVISOR simulation program. [6] These models were created to study the off-loading of engine loads for Class-8 long-haul diesel semi trucks. The hull fan model was scaled up to represent the hull fan power for the M2A3. The input shaft power required to spin each respective accessory is a function of engine RPM as shown in Figure 5.

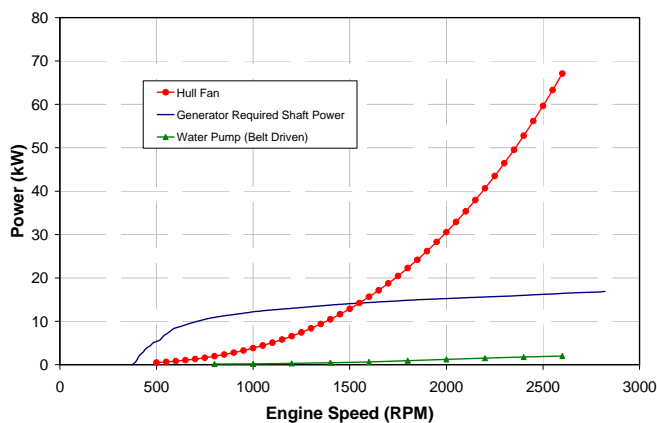

Figure 5: Mechanical Accessory Loads

Figure 6 shows that a 104 kW fuel cell APU would provide sufficient electrical power for a fully enabled M2A3, operating under maximum electrical load with electrically powered accessories replacing all mechanically driven accessories. This represents the

power necessary to operate electric motors for the hull fan and water pump at 2600 RPM, plus the standard electrical loads from the United Defense mobile scenario. Efficiencies chosen for the electric motor and inverter are 80 and 92 percent respectively.

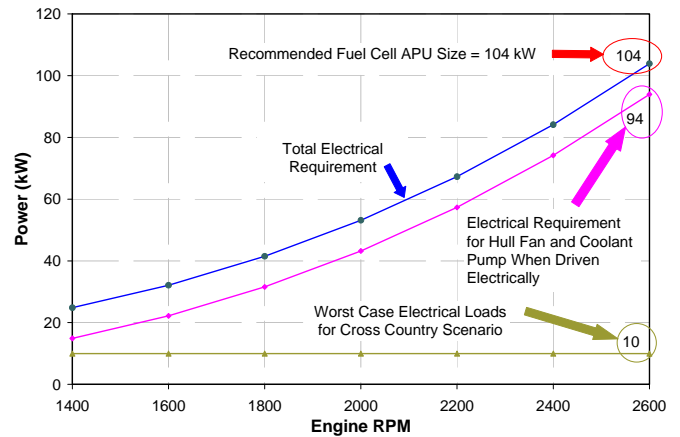

Figure 6 Powering Accessories: Electrical Sizing of APU

The values presented in Figure 7 are based on the maximum gross engine power curve. The net propulsion power available to move the vehicle is shown as the gross engine power minus the engine accessories. Thus, if these accessories are no longer driven by the engine, but instead electrically-driven by a fuel cell APU, the power available for propulsion becomes the top curve. The simulation results indicate that 86kW of power at 2600 rpm could be redirected to propulsion if the engine-driven accessories were replaced by electrically-driven equivalent devices. Figure 7 shows the benefit of off-loading the accessory loads from the engine. Note that as engine RPM increases, the hull fan consumes significantly more power. Thus the maximum benefit for off-loading the accessory devices will be obtained at maximum RPM

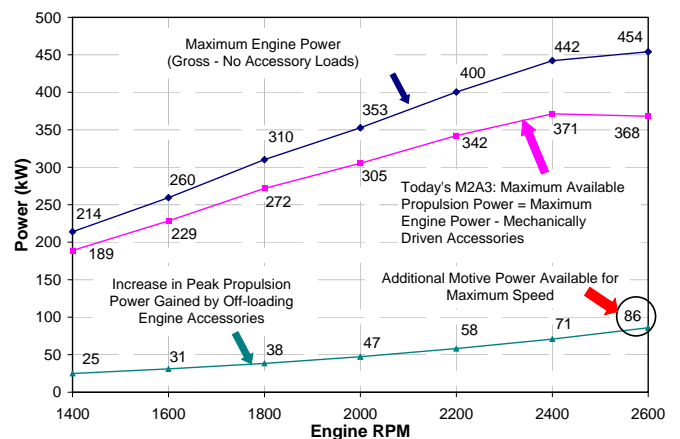

Figure 7: Improvement in Peak Engine Power

Note that this study does not take into account any of the potential advantages of optimizing the electrically-

driven accessories. For example, electrically-driven accessories may not have to run at the same worst-case scenario as their mechanical counterparts.

Figure 8 shows the predicted performance gains in 0 - 30 mph acceleration due to off-loading engine accessories. This acceleration is a key vehicle performance parameter. The result is derived using a first-order, physics-based approach using the change in kinetic energy of the vehicle. Using the recovered 86kW of engine power for propulsion results in a 2.1 second decrease in acceleration time. (i.e. 19% better acceleration time)

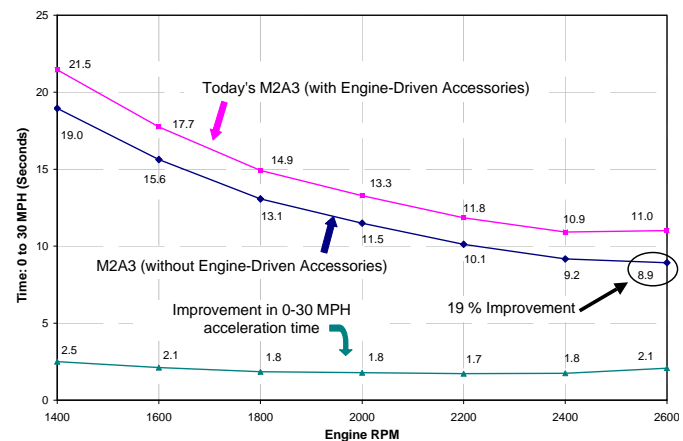

Figure 8: Improvement in 0 - 30 MPH Acceleration

The final study goal was to determine the fuel economy impact of off-loading the engine accessories at a single operating point: 75% of full output power (341 kW) at the maximum engine rpm (2600)². Since engine accessories are being off-loaded, more of the engine power is available for propulsion. To equalize the before-and-after comparison, net engine power for propulsion was the same for both cases. In the baseline case, 86 kW of the 341 kW was used for accessories, leaving 255 kW for propulsion. In the case with the fuel cell APU powering the accessories and providing 355A of electricity, the engine can be operated at the lower 255 kW output level because its power is now dedicated to only propulsion. The engine is fueled at this lower power level, but the fuel use of the APU must be added to arrive at a new total. Figure 9 shows the fuel consumption as a function of engine output power at the chosen operating point. The total fuel rate to maintain baseline performance is 9% higher than the baseline M2A3 with mechanically-driven accessories.

In summary, the off-loading of engine accessories to be electrically powered by a fuel cell APU does not appear

² This operating point was chosen as a realistic, representative set of conditions likely to be experienced during battlefield conditions.

attractive. Although an improvement in dash speed is predicted, there is a net fuel use increase due to off-loading the accessories because today they are driven directly from the engine at high efficiency. In addition, a 104kW fuel cell would represent a significant packaging challenge inside the M2A3.

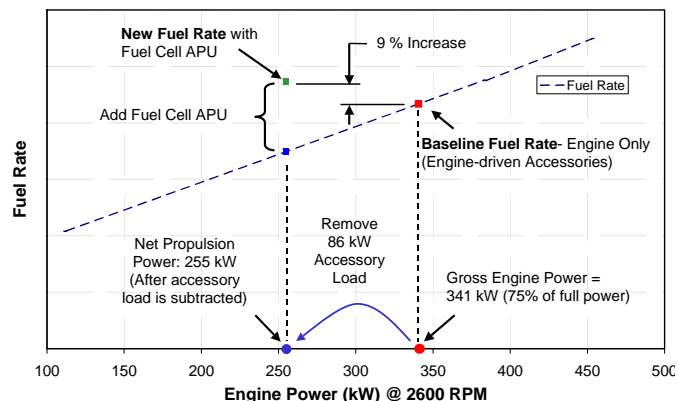

Figure 9 Fuel Economy Impact

CONCLUSIONS

- **Electrical Sizing – Silent Watch:** A 2.3 kW fuel cell APU power the M2A3 electrical loads during silent watch operational mode.
- **Fuel Savings:** Savings of up to 86% versus idling the main engine for silent watch mode are predicted for a solid oxide fuel cell APU.
- **Silent Watch Duration:** The 150 gallon main fuel tank of the M2A3 could provide APU silent watch continuously for 36 days.
- **Engine Accessories:** A 104 kW fuel cell APU would be necessary to supply power to all vehicle electrical loads plus an electrically-driven hull fan and engine water pump under all engine operating conditions.
- **Improvement in Acceleration:** If a fuel cell powers the engine accessories, the vehicle 0 to 30 mph acceleration is improved by 19% by utilizing the extra 86 kW of power for propulsion at 2600 rpm.
- **Fuel Economy Impact:** For the operating point studied, fuel use is increased by 9% by off-loading the electric loads, electric hull fan and electric water pump to a large fuel cell APU. This is because a diesel engine driving the large hull fan with a mechanical shaft is marginally more efficient than driving the hull fan with an electric motor supplied with power from a fuel cell APU. (Although this data shows an increase in fuel consumption for the case of rated power powering the "fully activated" electric engine accessories, there could be substantial potential fuel economy gains during part-loads when the benefits of having modulating accessories are fully realized. This case was outside the scope of this paper but should decidedly be taken into consideration in future work because it would more accurately reflect the full range of performance benefits of a fuel cell APU.)

Harry L. Husted, Engineering Manager, Delphi Corporation. Email: Harry.L.Husted@Delphi.com

Heather McKee, Project Engineer, US Army TACOM. Email: McKeeH@tacom.army.mil

ACKNOWLEDGMENTS

The US Army has provided funding for this work under subcontract agreement 1163609JP with TACOM.

REFERENCES

1. "Footprint Reduction 2 Study, CAA MTW – E1," US Army TACOM.
2. Venturi, M. et. al., "Recent Results on Liquid Fuelled APU for Truck Application," SAE Paper No. 2003-01-0266, Society of Automotive Engineers, Warrendale, PA, 2003.
3. Mathuria, P.H. et al, "Vibration and Shock Considerations in the Design of a Truck-mounted Fuel Cell APU System", SAE Paper No. 2002-01-3050, Society of Automotive Engineers, Warrendale, PA, 2002.
4. Lim, H., "Study of Exhaust Emissions from Idling Heavy Duty Diesel Trucks and Commercially Available Idle-Reducing Devices", SAE Paper No. 2003-01-0288, Society of Automotive Engineers, Warrendale, PA, 2003.
5. Zizelman, J., Shaffer, S., Mukerjee, S., "Solid Oxide Fuel Cell Auxiliary Power Unit – A Development Update", SAE Paper No. 2002-01-0411, Society of Automotive Engineers, Warrendale, PA, 2002.
6. Hendricks, T., O'Keefe, M., "Heavy Vehicle Auxiliary Load Electrification for the Essential Power System Program: Benefits, Tradeoffs, and Remaining Challenges". SAE Paper No. 2002-01-3135, Society of Automotive Engineers, Warrendale, PA, 2002.

DEFINITIONS, ACRONYMS, ABBREVIATIONS

APU: Auxiliary Power Unit

IFV: Infantry Fighting Vehicle

LHV: Lower Heating Value (of fuel)

PTO: Power Take Off

SECA: Solid State Energy Conversion Alliance

SOFC: Solid Oxide Fuel Cell

TACOM: US Army Tank-automotive and Armaments Command

TOW: Tube-launched, optically-tracked, wire-guided (missile)

UD: United Defense

CONTACTS

APPENDIX – M2A3 ELECTRICAL LOAD SUMMARY

Electrical Load Summary Used for Simulation (In Amperes)			
	Idle	Driving	Silent
#2: Silent Watch	N/A	N/A	83
Enhanced Silent Watch: Silent Watch + Turret & Gun Loads	N/A	N/A	108
#1: Normal Operation	135	139	N/A
#3: Water Crossing	175	179	N/A
#4: #1 + Combat: Turret & Gun	160	230	N/A
#5: #4 + MCD, BELRF	182	252	N/A
#6: #5 + NBC	273	343	N/A
#7: #6 + MCS	285	355	N/A

The following charts describe in more detail the particular loads included in each scenario.

Scenarios # 1 & #2: Normal Operational Loads

Load	Name	Load	Name
1	Applique CPU	21	Turret Equipment Cooling Fan
2	BCIS Transmit	22	Turret PCM1, PCM2
3	Receive	23	Turret Power Box (TPB)
4	CIU Circuit A	24	Turret Processor Unit (TPU)
5	CIV EU Circuit B	25	Vehicle Intercom System
6	Commander's Handstation (CHS)	26	Receive
7	Commander's Sight Control Panel (CSCP)	27	Commander's Data Entry Tool (CDET)
8	Commander's Tactical Display (CTD)	28	Digital Compass Display (DCD)
9	Ethernet Hub	29	Driver's Vision Enhancer (DVE)
10	External Training Devices (ETD)	30	Enhanced Position Location Reference System (EPLRS)
11	Gunner's Handstation (GHS)	31	Fuel Pumps
12	Gunner's Sight Control Panel (GSCP)	32	Global Positioning System (GPS)
13	Hull PCM3	33	Gun Control Unit (GCU)
14	Hull Processor Unit (HPU)	34	Missile Control Subsystem (MCS) - Standby
15	Hull Ventilation Fans	35	Position Interface Box (PIB)
16	IBAS Electronics Unit	36	Single Channel Ground-Airborne Radio System (SINCGARS) Transmit
17	Master Power	37	Squad Leader's Display (SLD)
18	Personnel Heater	38	Turret Drive Control Unit (TDCU)
19	SSES Laser Warning Receiver	39	Vehicle Lighting System
20	System Control Box (SCB)	40	Winterization Kit

Scenario # 3: Water Crossing

41	Bilge Pumps
----	-------------

Scenario # 4: Combat - Turret and Gun Movement

42	Traverse Drive: Low	46	TOW Lift
43	High	47	TOW Elevation: Low
44	Gun Elevation: Low	48	High
45	High	49	Stabilization
		50	Weapon Firing

Scenario # 5: Combat: Turret and Gun Movement, MCD & BELRF

51	Missile Countermeasures Device (MCD): Low Power	52	Bradley Eye-safe Laser Range Finder (BELRF)
----	--	----	---

Scenario # 6: Combat: Turret and Gun Movement with NBC, MCD & BELRF

53	Nuclear, Biological, and Chemical filters (NBC) / Gas Particulate Filter Unit (GPFU) System
----	---

Scenario # 7: Combat: Turret and Gun Movement with MCS operation, NBC, MCD & BELRF

54	Missile Control System - Operation
----	------------------------------------