

# **JOINT DESIGN FOR ADVANCE CERAMIC ARMOR UNDER BALLISTIC IMPACT**

Hui Wang  
MKP Structural Design Associates, Inc., Ann Arbor, MI 48104

Zheng-Dong Ma<sup>\*</sup>, Noboru Kikuchi, and Christophe Pierre  
Department of Mechanical Engineering, University of Michigan, Ann Arbor, MI 48109

Basavaraju Raju  
US Army Tank-Automotive and Armaments, Warren, MI 48397

## **ABSTRACT**

The objective of this research is to develop a new methodology with software tools for the joint design of an advanced composite armor (ACA) under ballistic impact and other loading conditions. An innovative design methodology, topology optimization, is extended for the composite armor joint design problem. This includes ballistic impact analyses of the ACA, function analyses and targets setting of the various types of the joints in the ACA, algorithms of the optimal design process, and the design optimization of the joints. The performance of a nominal joint design is evaluated using LS-Dyna3D, which provides loading conditions for the optimal design process of an advanced joint. The final goal is to lay out a new joint concept that improves the structural performances and prevents the early damage of the joints under ballistic impacts. Other design objectives, such as manufacturability and reliability of the design, will also be considered in the future. Examples are provided to demonstrate the effectiveness of the new design methodology developed.

**KEY WORDS:** Advanced Composite Armor (ACA), Joint Design, Topology Optimization

## **1. INTRODUCTION**

Extensive attention has been paid on ballistic impact simulation and composite armor design with the development of advanced material models and simulation software. As with the application of other composite materials, connections (or so-called joints) of a composite armor with the other structural parts, e.g., a metal frame in a military vehicle, are among the weakest places in the structure. The joint design for composite armors is no doubt a great challenge for the advanced army vehicles. State-of-the-art researches are concentrated on simple metallic or composite joints under static and low-speed loading conditions. The performances of these joints under ballistic impact are not well understood, and the design problem of the joints for advanced composite armors is not adequately addressed.

---

<sup>\*</sup> Correspondence author, Email: [mazd@engin.umich.edu](mailto:mazd@engin.umich.edu), Tel: 734-764-8481

# Report Documentation Page

Form Approved  
OMB No. 0704-0188

Public reporting burden for the collection of information is estimated to average 1 hour per response, including the time for reviewing instructions, searching existing data sources, gathering and maintaining the data needed, and completing and reviewing the collection of information. Send comments regarding this burden estimate or any other aspect of this collection of information, including suggestions for reducing this burden, to Washington Headquarters Services, Directorate for Information Operations and Reports, 1215 Jefferson Davis Highway, Suite 1204, Arlington VA 22202-4302. Respondents should be aware that notwithstanding any other provision of law, no person shall be subject to a penalty for failing to comply with a collection of information if it does not display a currently valid OMB control number.

1. REPORT DATE <b>12 NOV 2004</b>		2. REPORT TYPE <b>Journal Article</b>		3. DATES COVERED <b>17-04-2004 to 25-10-2004</b>	
4. TITLE AND SUBTITLE <b>JOINT DESIGN FOR ADVANCE CERAMIC ARMOR UNDER BALLISTIC IMPACT</b>				5a. CONTRACT NUMBER	
				5b. GRANT NUMBER	
				5c. PROGRAM ELEMENT NUMBER	
6. AUTHOR(S) <b>Hui Wang; Basavaraju Raju; Zheng-Dong Ma; Noboru Kikuchi; Christophe Pierre</b>				5d. PROJECT NUMBER	
				5e. TASK NUMBER	
				5f. WORK UNIT NUMBER	
7. PERFORMING ORGANIZATION NAME(S) AND ADDRESS(ES) <b>MKP Structural Design Associates, Inc., 6869 Marshall Road, Dexter, Mi, 48130</b>				8. PERFORMING ORGANIZATION REPORT NUMBER <b>; #14237</b>	
				10. SPONSOR/MONITOR'S ACRONYM(S) <b>TARDEC</b>	
9. SPONSORING/MONITORING AGENCY NAME(S) AND ADDRESS(ES) <b>U.S. Army TARDEC, 6501 East Eleven Mile Rd, Warren, Mi, 48397-5000</b>				11. SPONSOR/MONITOR'S REPORT NUMBER(S) <b>#14237</b>	
12. DISTRIBUTION/AVAILABILITY STATEMENT <b>Approved for public release; distribution unlimited</b>					
13. SUPPLEMENTARY NOTES					
14. ABSTRACT <b>The objective of this research is to develop a new methodology with software tools for the joint design of an advanced composite armor (ACA) under ballistic impact and other loading conditions. An innovative design methodology, topology optimization, is extended for the composite armor joint design problem. This includes ballistic impact analyses of the ACA, function analyses and targets setting of the various types of the joints in the ACA, algorithms of the optimal design process, and the design optimization of the joints. The performance of a nominal joint design is evaluated using LS-Dyna3D, which provides loading conditions for the optimal design process of an advanced joint. The final goal is to lay out a new joint concept that improves the structural performances and prevents the early damage of the joints under ballistic impacts. Other design objectives, such as manufacturability and reliability of the design, will also be considered in the future. Examples are provided to demonstrate the effectiveness of the new design methodology developed.</b>					
15. SUBJECT TERMS <b>Advanced Composite Armor (ACA), Joint Design, Topology Optimization</b>					
16. SECURITY CLASSIFICATION OF:			17. LIMITATION OF ABSTRACT <b>Public Release</b>	18. NUMBER OF PAGES <b>13</b>	19a. NAME OF RESPONSIBLE PERSON
a. REPORT <b>unclassified</b>	b. ABSTRACT <b>unclassified</b>	c. THIS PAGE <b>unclassified</b>			

**1.1 Advanced Composite Armors** Advanced composite armors (ACAs) are usually multi-layers consisting ceramic material, fiber-reinforced polymers, metallic screen, and possibly rubber materials. These layers serve specific purposes in defeating projectiles and maintaining structural integrity of the armor as well as the rest vehicle structures. The outmost layer of the ACA is usually fiber reinforced polymers for the purpose of maintaining structural integrity. Ceramic material in the second layer has functions such as destroying the tip of the projectile, distributing the impact load over a large area of the composite, and decelerating the projectile. The inner composite layers support the ceramic and perform other functions such as holding the ceramic debris together and further resisting the projectile. The performance of each layer significantly influences the overall performance of the armor. ([1], Kaufmann et al. [21] )

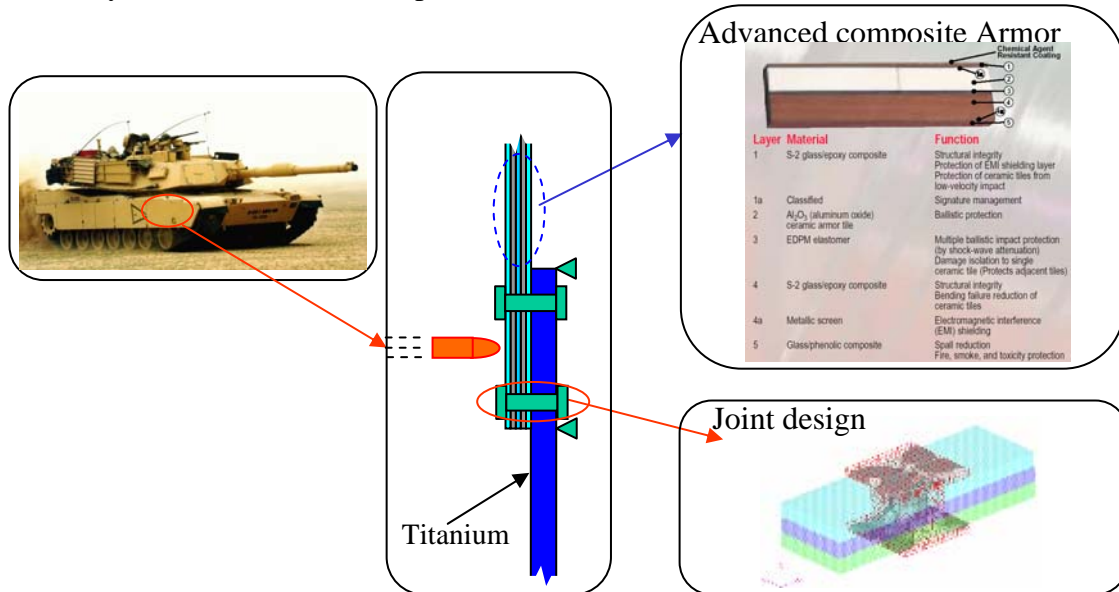

Figure 1. An Joints design with quasi-static and ballistic concerns.

This paper concentrates on a special design problem for the ACA, namely the joint design between an advanced composite armor and a vehicle structure. We investigate influences of two different layouts of composite armor on the performances of joints, especially, under ballistic impacts. The objective is to layout the optimum joints in terms of their sizes and shapes in order to maintain the structural integrity as well as improve the other performances of the ACA. It is found that both armor configuration and joint design have great impacts on the overall performances of the armor.

Previous studies found in literature regarding the armor design have considered material types (Kaufmann et al. [21]) and dimensions, such as thickness, as design variables.[2] Very little research, however, can be found on the subject of joint design for composite armors. In this paper, we consider a design problem shown in Figure 1. It is seen in Fig.1 that the connection between ACA and metal structure is critical in the sense that ACA may fall off if the connection is damaged due to static, dynamic or ballistic loads. The major concern in this research is the joint design, and it is found that different ACA designs can significantly influence the performances of the joints.

**1.2 Topology Optimization** A breakthrough technique for the topology optimization of structural systems was developed by Bendsøe and Kikuchi in 1988 [3], and it has since become known worldwide as the homogenization-based topology optimization method. The basic idea in this new structural optimization technique is to transform the optimal topology design problem into an equivalent Optimal Material Distribution (OMD) problem, using a composite material that has a variable microstructure [3-5]. As shown in Fig. 2a, consider that the structural domain is filled with a non-homogeneous composite material with a variable microstructure. As a simplification, consider a plane-stress problem, and assume that the microstructure is formed inside an empty rectangle in a unit cell with three design variables  $a$ ,  $b$  and  $\theta$ . Here,  $a$  and  $b$  stand for sizes of the microstructure and  $\theta$  the orientation of the microstructure. In the optimization process, the microstructure can vary between “empty” and “solid” using the design variables  $a$  and  $b$ , and can be rotated using the orientation variable  $\theta$ . The microstructure becomes a complete void when  $a=b=0$ , and a complete solid when  $a=b=1$ . Therefore, if one assumes that the total amount of the material, which is prescribed for the design problem at hand, remains constant in the optimization process, then the material will be moved from a region of the structural domain into another region to produce a new distribution of the material, as depicted in Fig. 2b. By moving and orienting the material so as to improve the objective function of the optimization problem, one can finally obtain an OMD that corresponds to the optimal structure. This approach can be easily extended to a three-dimensional problem.

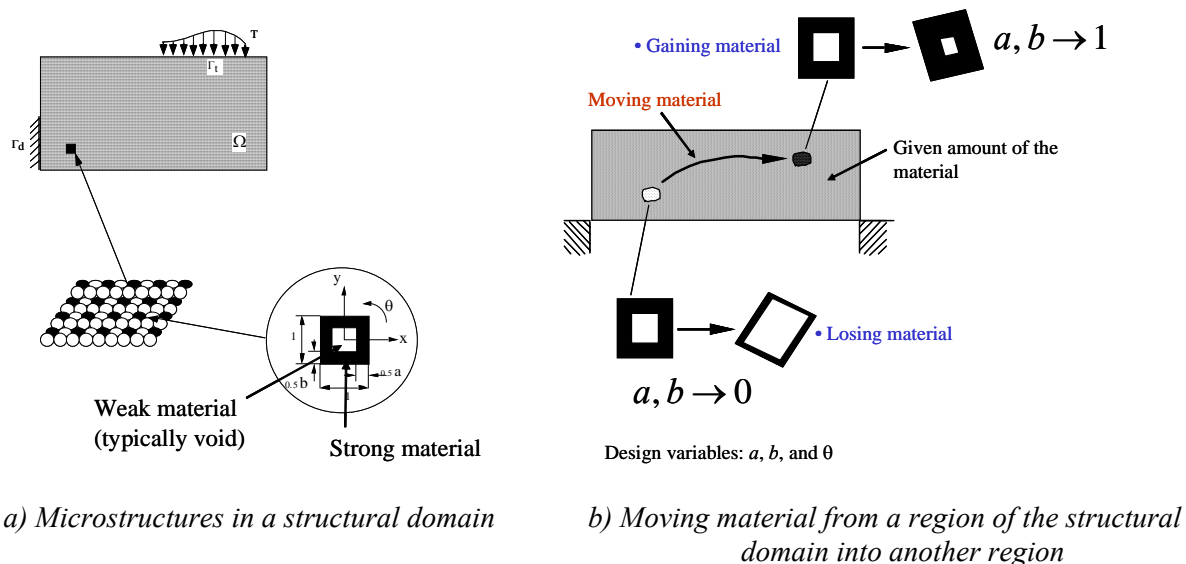

Figure 2. Basic concept of the homogenization based topology optimization method

The topology optimization method described above has been applied to various areas, including structural design and material design [5]. It has also been used in the design of structures, materials, and micro-electro-mechanical system (MEMS), for achieving static stiffness [3, 6-7], mechanical compliance [8-10], desired eigenfrequencies [11-14], other dynamic response characteristics [4, 15-16], desired material properties [17-18], and unusual thermo-elastic properties [19].

**1.3 Design Strategy for Joints between Armor and Main Structure** Testing is currently the major part of advanced armor design process. However, virtual prototyping is gradually accepted as an alternative tool for armor design because of the advances in material models and simulations codes. In this research, virtual prototyping technique is developed for conducting the design problem and verifying the results. In the future, experiments will be considered as a validation tool for further proof of concept and to compare the nominal joint design with the improved new designs.

The design procedure is explained in the following Figure 3. As the first step, we conduct virtual prototyping with commercial code (LS-Dyna3D). The potential problems with a nominal joint (bolt) design are identified. Then, design objectives, variables, loads, and constraints are derived, with which the design problem is constructed and optimal design is obtained. The new design is evaluated again with LS-Dyna3D. In each design cycle the performances are improved using the topology optimization method, and this design process can be iterated until a suitable design is obtained.

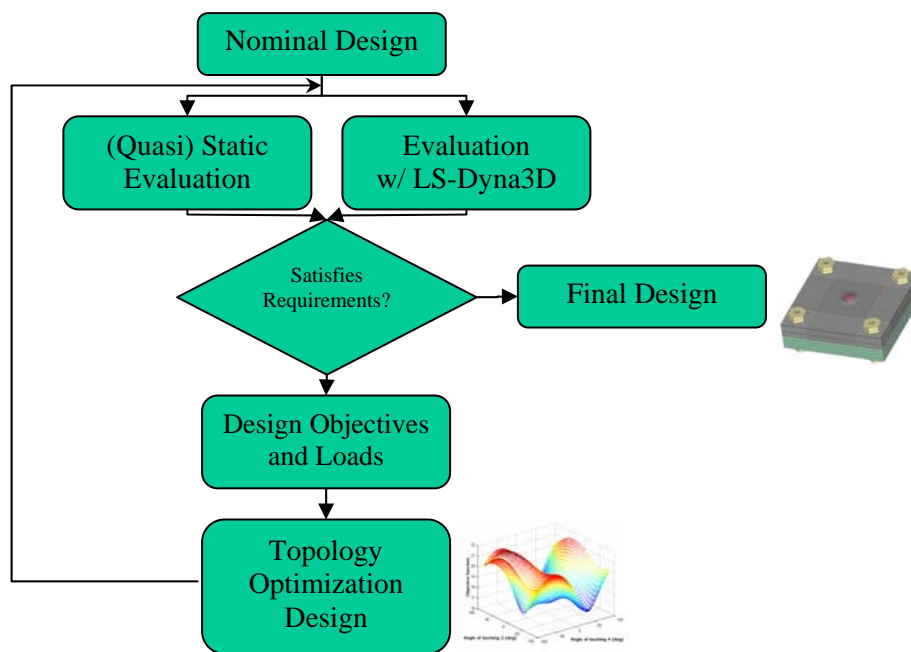

Figure 3. Design loops of ACA joints

## 2. MATERIAL MODEL

**2.1 Ceramics** The most widely used material model for ceramics is Johnson-Holmquist (JH2) ceramics model. (Johnson and Holmquist [20]) This model has been implemented in several commercial softwares, including Epic, Autodyn, and LS-Dyna3D. The model is widely applied in armor simulation and design, and many reports can be found in literature. [20,22-24] LS-Dyna3D is selected as the simulation tool because of its advantage as the most widely used general-purpose code for the problem. Many advanced material models and numerical methods are also available in LS-Dyna3D. The material model (JH2) is named as material 110 (\*MAT\_JOHNSON\_HOLMQUIST\_CERAMICS). Material parameters are adopted from

literatures for the current research. Silicon carbide (SiC) is selected as the ceramic material, and material parameters are given as:

$$\begin{aligned} \rho &= 3163 \text{ Kg/m}^3, \quad G = 183 \text{ GPa}, \\ A &= 0.96, \quad B = 0.35, \quad C = 0.0, \quad M = 1.0, \quad N = 0.65, \\ \text{Ref Strain Rate (EPSI)} &= 1.0, \quad \text{Tensile Strength} = 0.37 \text{ GPa}, \\ \text{Normalized Fracture Strength} &= 0.8, \\ \text{HEL} &= 14.567 \text{ GPa}, \quad \text{HEL Pressure} = 5.9 \text{ GPa}, \\ \text{HEL Strength} &= 13.0 \text{ GPa}, \\ D_1 &= 0.48, \quad D_2 = 0.48, \\ K_1 &= 204.785 \text{ GPa}, \quad K_2 = K_3 = 0.0, \quad \beta = 1.0, \end{aligned}$$

**2.2 Fiber Reinforced Polymers (FRPs)** The same material model was used for fiber reinforced polymer layers of ACA as those in the work of Yen et al. [25] The material parameters (\*MAT\_COMPOSITE\_MSC) are given as:

$$\begin{aligned} E_x = E_y &= 24.1 \text{ GPa} & E_z &= 10.4 \text{ GPa} \\ \nu_{xy} &= 0.12 & \nu_{xz} = \nu_{yz} &= 0.12 \\ G_{xy} = G_{yz} = G_{zx} &= 5.9 \text{ GPa} \\ S_{xT} = S_{yT} &= 0.59 \text{ GPa} & S_{xC} = S_{yC} &= 0.35 \text{ GPa} \\ S_{FS} &= 0.55 \text{ GPa} & S_{FC} &= 0.69 \text{ GPa} \\ S_{xy} = S_{yz} = S_{zx} &= 48.3 \text{ MPa} & S_{xCR} = S_{yCR} &= 0.10 \text{ GPa} \\ S &= 1.4 & C &= 0.1 \\ \phi &= 40^\circ & m &= 4 \\ \rho &= 1783 \text{ Kg/m}^3 \end{aligned}$$

### 3. FUNCTIONAL ANALYSIS

The geometry and dimension of an ACA and the size and locations of the bolts are shown in Figure 4. This model is considered as the nominal design in this research. The projectile is assumed to be tungsten with spherical-shaped tip, and the dimension of the projectile is shown in Figure 4.

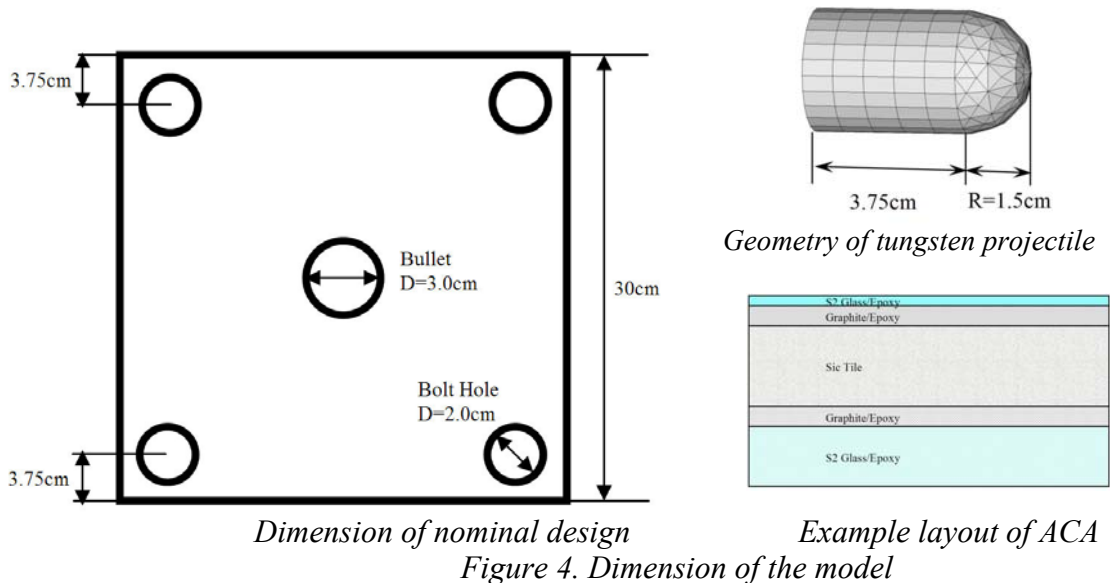



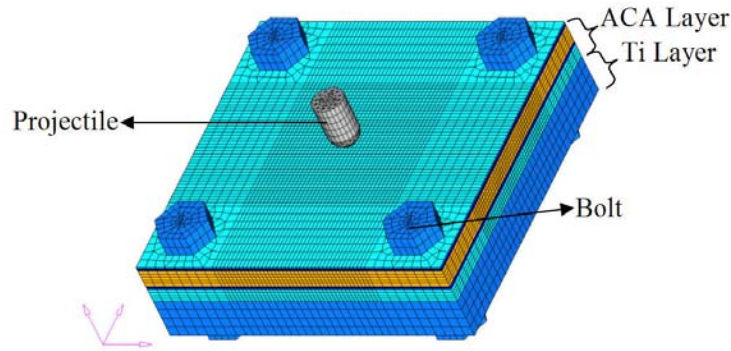

Figure 5. FEA mesh for ACA and projectile

The finite element mesh is shown in Figure 5. Altogether, 43,580 elements and 49,678 nodes are included in the ACA and bolts model. The ACA and Ti layers are defined as simply in contact. It takes 2-6 hours to make one simulation on a 3.06GHz PC with 1.5G memory. It was found that LS-Dyna3D v970 is more stable, and satisfactory results were obtained.

Simulation results were first obtained with different materials for projectile and different ACA designs. The materials for the projectile were considered to be steel or tungsten. Compared to steel, tungsten has much higher density. Other benefits with tungsten, such as high hardness and melting temperature, also contribute to the wide application of tungsten projectiles. Tungsten is therefore selected to be the material for the projectile in the following studies.

**3.1 All-Ceramic Armor** All-ceramic armor was first considered, and back plate was assumed to be made of Ti. The initial velocity of projectile was assumed to be 800m/s. The damage process for the armor/Ti structure is shown in the following Figure 6.

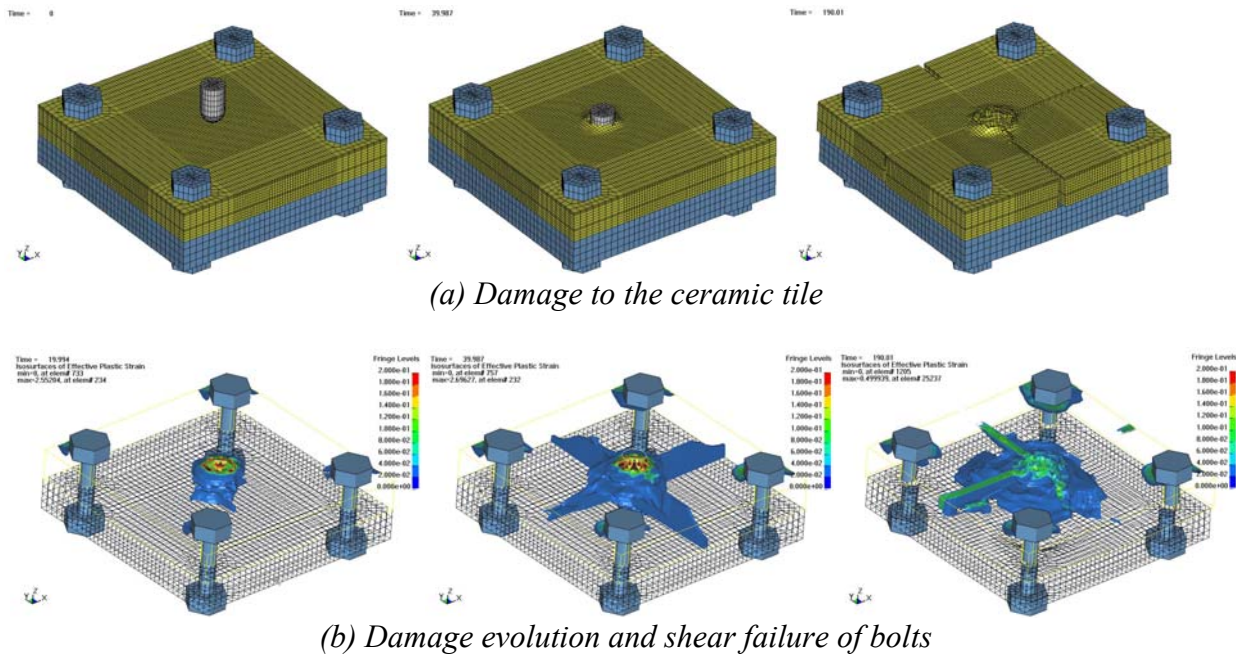

Figure 6. The process of ballistic impact on all-ceramic armor/Ti assembly.

The velocity history of projectile predicted using the simulation tool is shown in Figure 7. The projectile penetrating process includes tip damages of the projectile, compression damage of the ceramic, ceramic damage due to reflective tensile wave in the opposite side of armor, radial cracking due to bending, fracture cone formation, crack expansion to the edges, plastic deformation of the back plate, and shear failure of the bolts.

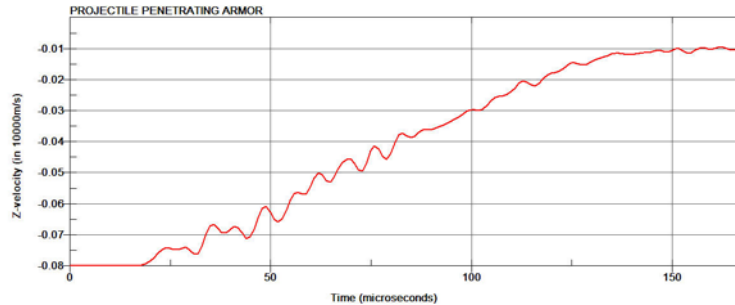

Figure 7. Change of projectile velocity with time

From the simulation result, it is seen that although the projectile did not penetrate the armor-metal structure, the bolts were broken due to expansion of broken armor and the deformation of the back plate. As a result, armor layer can fall off and lose protection against the subsequent attacks. Although no experiment was conducted to verify the current simulation results, researchers have reported that broken ceramic tiles can cause damages to the neighboring ceramic tiles. One example was reported in the work of Zaera et al. [26] as shown in the right-top picture in Fig. 11. When the expansion force acts on the bolts against constraint force from metal plate, the bolts can be sheared to failure.

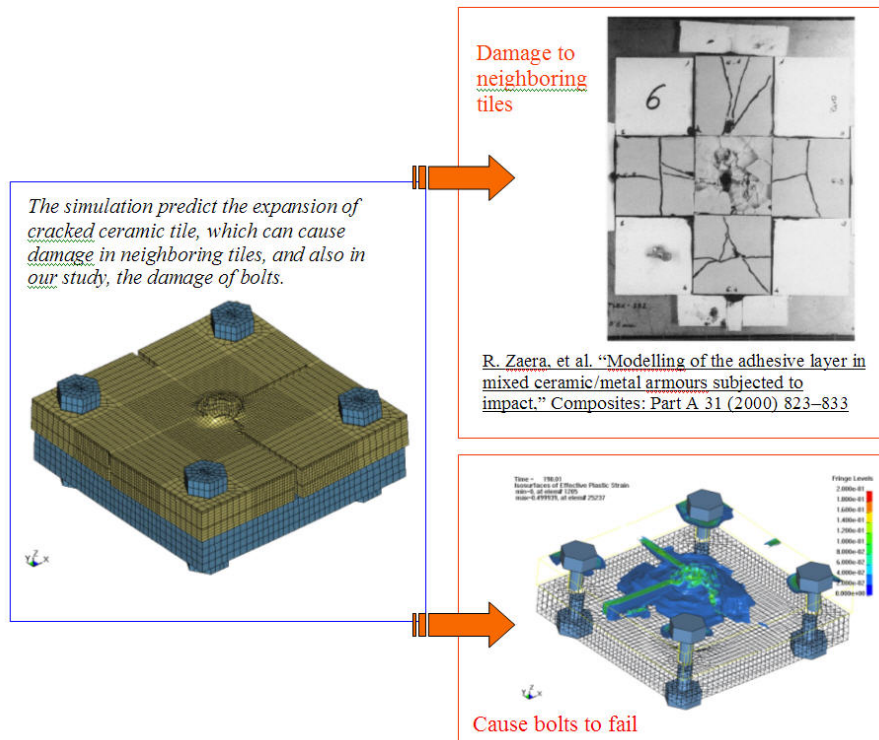

Figure 8. Ballistic impact on armor cause damage in bolts and neighboring tiles



Figure 9 illustrates the load acting on one of the bolts in the middle section with the description of the corresponding penetrating stages. It can be seen that bolts fail as a result of the expansion of broken tiles and the deformation of back plate. With the failure of bolts, structural integrity will be lost, and armor will fall off. With this analysis, the importance of joint (bolts) design is clear.

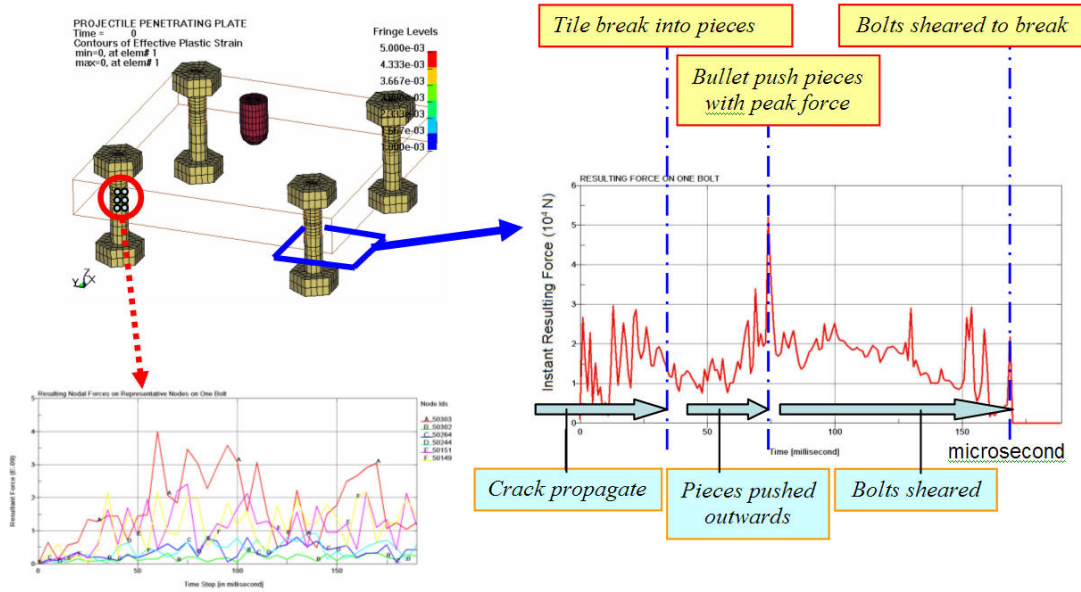

Figure 9. Force acting on one bolt during ballistic impact

**3.2 Composite Armor** It is widely recognized that all-ceramic armors have weakness, such as easy crack propagation and armor damage due to reflective shock wave on the back surface of the armors. Therefore, special advanced composite armors were developed to improve the performances. In [1], ceramic-based armors were investigated, in which fabrics or fiber reinforced polymers were utilized. The ballistic performances of joints connecting ACA and metal structure were evaluated as a comparison to all-ceramic armors.

The same projectile with velocity of 800m/s is considered here.

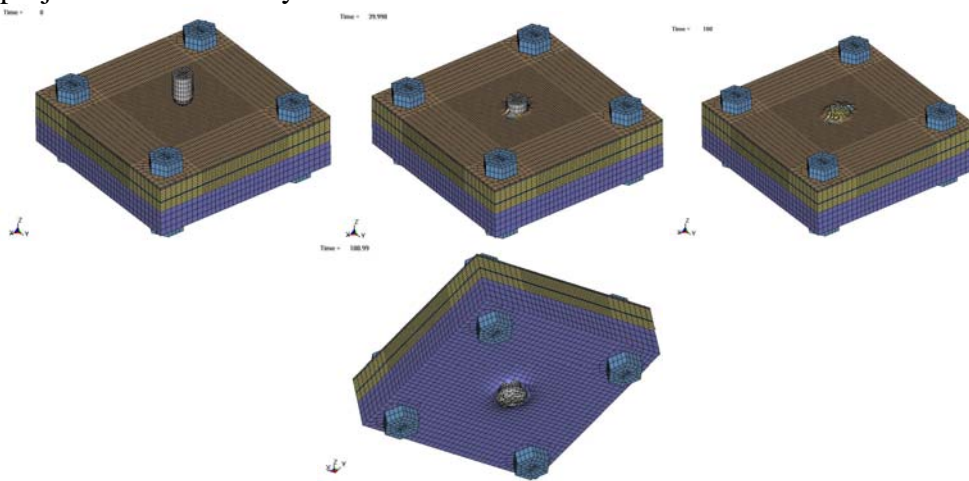

Figure 10. Penetration of projectile through ACA and Ti substrate.

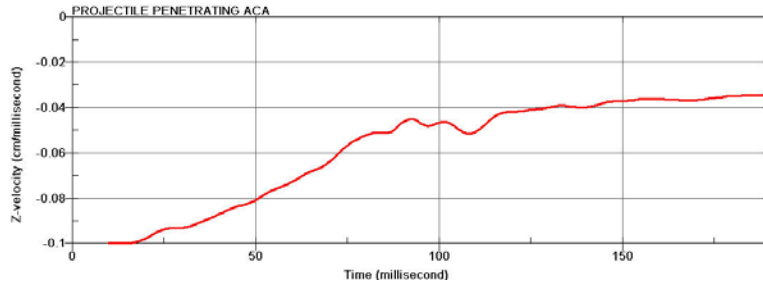

Figure 11. The changing velocity of projectile with time

From Figure 11, it can be seen that the projectile penetrates the ACA and Ti substrate, and the exist velocity of projectile is 370m/s. The thickness of ceramic layer is not enough to defeat the projectile. It is also observed that because the ceramic layer did not crack and expand much, the bolts remained undamaged.

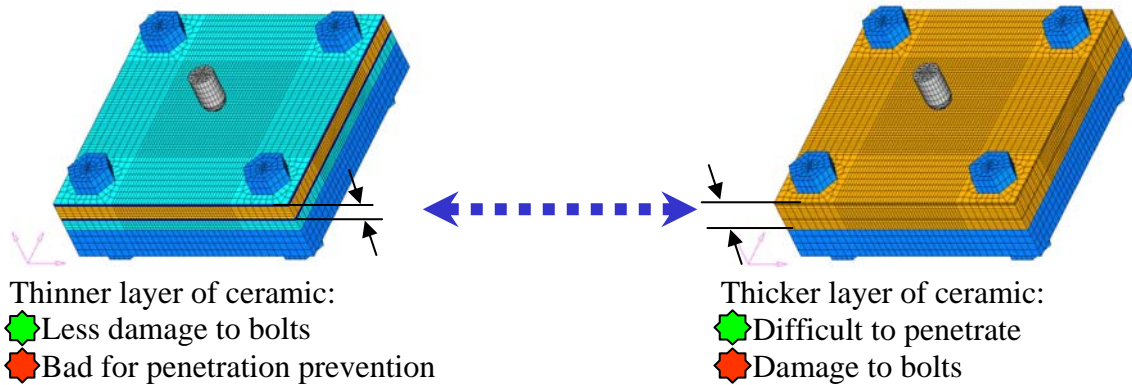

Figure 12. Influences of thickness of ceramic layer on the performances of armor and bolts

One important area of composite armor optimization is thickness optimization of each layer for better overall ballistic performances. The thickness changes influence the performance of bolts, which is illustrated in Figure 12. The thickness of ceramic layer should be decided according to the requirement of defeating the projectile. In this research, the projectile is assumed to remain the same. To prevent penetration, the thickness of ceramic layer needs to be large. As a result, the bolts will have a higher possibility of failure. Therefore advanced design methods are needed to improve the performances of joints in this situation. In the following sections, all-ceramic armor is considered as an example, but the design method developed can be applied to advanced composite armors.

#### 4. DESIGN PROBLEM

With the functional analyses described in the previous section, influences of ballistic impact on joints (bolts) can be identified, and objectives for joint (bolt) design can be determined. The joint design of ACA with the supporting structure should consider both (quasi-)static and ballistic loads. The design of joints with (quasi-)static concerns can be completed with our existing tools, which will not be reported here. The locations of bolts also have influences on the performances

of bolts, but, in the current research, the bolt locations are assumed to be unchanged. The detailed bolt design, including configuration, dimension, and shape, is considered. The forces on a selected bolt are illustrated as cross-sectional forces in 10 cross sections, which are shown in Fig. 13. The overall forces on the bolts are large due to expanding of the damaged armor.

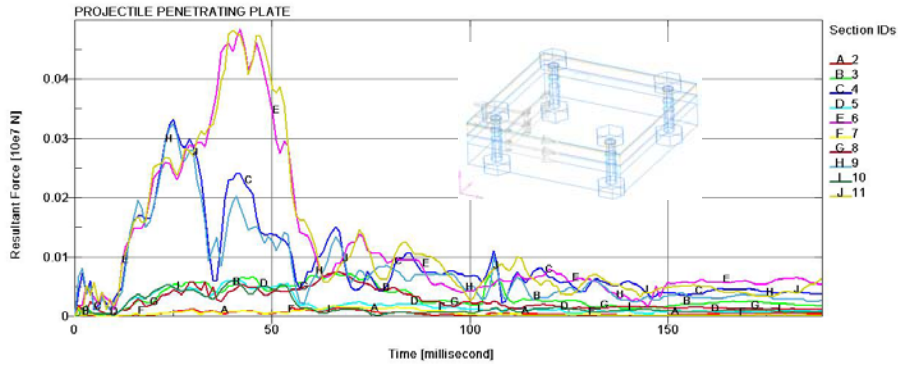

Figure 13. Cross-sectional forces inside ceramic layer

From the Figure 13, it is seen that the expanding force inside the ceramic layer is much higher in the lower half of the thickness. This can be attributed to the crack cone formation inside the ceramic and expansion of damage material in the lower half.

In Figure 14, a joint design problem is described. The blue area is the design domain with which the geometry and shape of the reinforcement structure of the bolt will be laid out. Non-design domains, which represent the armor and plate, are shown in wire plots. The loads used for the design problem, which are acting on the non-design ceramic tile, are obtained from the aforementioned ballistic simulation.

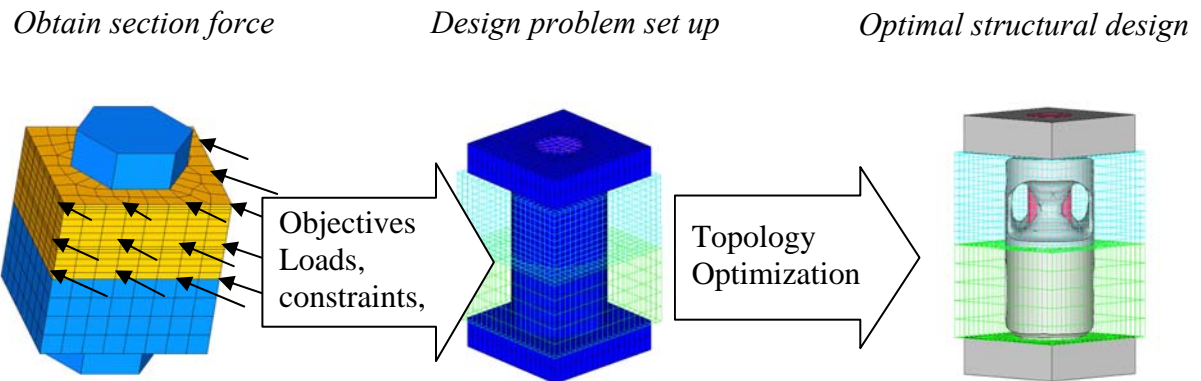
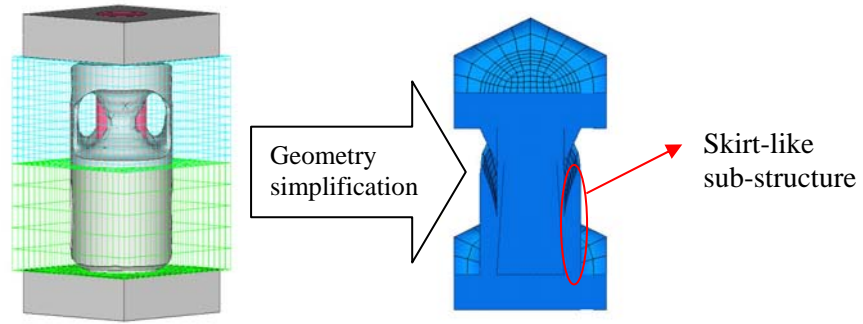

Figure 14. Detailed bolt design

With the post-processing program developed by the authors, the design result is obtained and shown in Figure 15. It is seen that the shape of new bolt design is responding to the shear loads acting on the bolts during the ballistic impact. An important feature of this new design is that it allows large shear deformation, which reduces the damage of the main bolt part due to the tile expansion. A simple larger-diameter design of the bolts will not have this feature, thus won't solve the problem of bolt failure due to the large force acting on the bolts.



(a) design from topology optimization tools (b) modified design (cut in half to show the cross section shape)

Figure 15. Designs from topology optimization design tools

From the Figure 15, it is seen that the optimum design from topology optimization has a complicated geometry, which will pose a problem for the manufacturing and assembly process. Simplification of the geometry is therefore necessary and the modified design is shown in right figure in Figure 15.

Verification of the new design is carried out with the virtual prototyping. The results are shown in Figure 16(a). From this result, it can be seen that the bolts did not fail, although skirt-like substructure of the bolt was crushed. In real applications, this substructure can be design as a separate part of the bolt for easy manufacturing. It is also found that there is another benefit from this new design: in normal condition, the liner is strong enough to keep armor in position. When large forces act on the bolts due to ballistic impact, the liners undergo plastic deformation. The main structure of the bolts do not deform much, and the bolts will not break. As a result, the new bolts ensure connection between armor and metal structure in working condition and keep the structural integrity through local plastic deformation under ballistic impact.

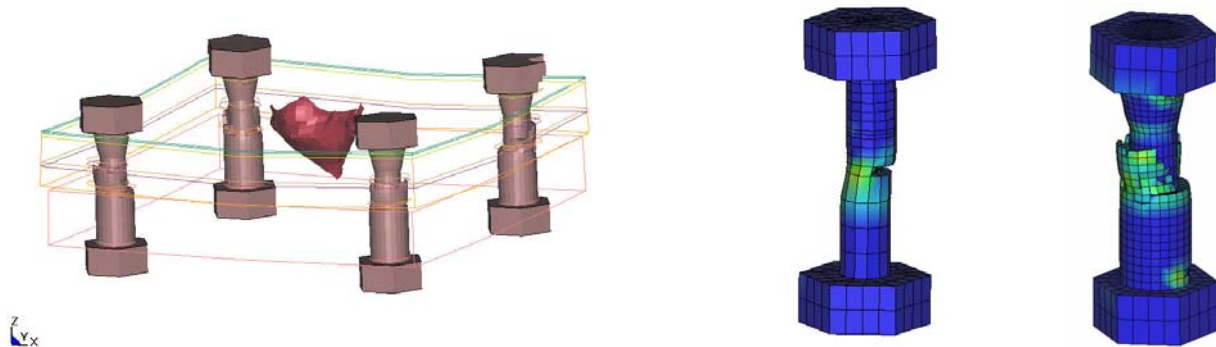

(a) Final state of the impact

(b) Nominal and new bolts after impact

Figure 16. Bolts remain unbroken and keep structural integrity

The final shapes of bolts for nominal and improved designs under ballistic impact are shown in more detail in Figure 16(b). It can be seen that for the new design, the main structures of bolts have much less plastic deformation and, as a result, the bolts don't break. The ballistic performances of bolts have been improved to keep structural integration under ballistic impact.

## 5. CONCLUSIONS

In this research, the influences of ballistic impact on joints (bolts) were investigated through virtual prototyping using a commercial code. It is concluded that bolts may fail during the ballistic impact if not designed properly. Failures of bolts may result in losing the structural integrity of ACA/main frame system. An optimal design problem has been then considered and corresponding design procedures are developed to address the ballistic concerns. It should be noted that the current research utilized the material parameters available in the literature with assumed geometry parameters. The examples are presented to demonstrate the capabilities of the current design methodologies. The presented methods can be applied to the real composite armor to improve its performance and to reduce its weight.

## 6. REFERENCES

1. WWW: <http://www.arl.army.mil/wmrd/Tech/CompositeArmor-both.pdf>
2. H. Kurtaran, M. Buyuk, and A. Eskandarian, Int. J. Impact Engrg., 29, 397 (2003).
3. M. P. Bendsøe, and N. Kikuchi, Comput. Methods. Appl. Mech. Engrg., 71, 197 (1988).
4. Z.-D. Ma, N. Kikuchi, and H.-C. Cheng, Comput. Methods Appl. Mech. Engrg., 121, 259 (1995).
5. Bendsøe, M. P., Optimization of Structural Topology, Shape, and Material, Springer-Verlag Berlin Heidelberg, 1995.
6. K. Suzuki, and N. Kikuchi, Comput. Methods Appl. Mech. Engrg., 93, 291 (1991).
7. N. Kikuchi, K. Suzuki, and J. Fukushima, in G. I. N. Rozvany, ed., Optimization of Large Structural Systems, NATOASI Series (Berchtesgaden) 3, 1991, pp. 110-126.
8. N. Kikuchi, S. Nishiwaki, J.O. Fonseca, and E.C.N. Silva, Comput. Methods Appl. Mech. Engrg., 151, 401 (1998).
9. S. Nishiwaki, M. Frecker, S.J. Min, and N. Kikuchi, Int. J. Numer. Methods Engrg., 42, 535 (1998).
10. M. Frecker, G.K. Ananthasuresh, N. Kikuchi, and S. Kota, Journal of Mechanical Design, ASME Transactions, 119(2), 238, (1997).
11. A. Diaz, and N. Kikuchi, Int. J. Numer. Methods Engrg., 35, 1487 (1992).
12. Z.-D. Ma, N. Kikuchi, H.-C. Cheng, and I. Hagiwara, Computing System in Engineering, 5(1), 77, (1994).
13. Z.-D. Ma, N. Kikuchi, H.-C. Cheng, and I. Hagiwara, ASME Journal of Applied Mechanics, 62, 200, (1995).
14. H.-C. Cheng, N. Kikuchi, and Z.-D. Ma, Proceeding of the ASME International Mechanical Engineering Congress and Exposition, PED-68-2(2), 1994, pp. 483.
15. Z.-D. Ma, H.-C. Cheng, N. Kikuchi, and I. Hagiwara, Recent Advances in Structural Problems, PVP-248/NE-10, 1992, pp. 133.
16. Z.-D. Ma, N. Kikuchi, and I. Hagiwara, Computational Mechanics, 13(3), 157, (1993).
17. J.S.O. Fonseca, Design of Microstructures of Periodic Composite Materials, Ph.D. Thesis, The University of Michigan, 1997.
18. E.C.N. Silva, S. Nishiwaki, J.S.O. Fonseca, and N. Kikuchi, Compt. Methods Appl. Mech. Engrg., 172, 241 (1999).

19. B.-C. Chen, E.C.N. Silva, and N. Kikuchi, Int. J. Numer. Meth. Engng, 52, 23, (2001).
20. G.R. Johnson, and T.J. Holmquist, High Pressure Science and Technology-1993, AIP, New York, 1994, pp. 981-984.
21. C. Kaufmann, D. Cronin, M. Worswick, G. Pageau, and A. Beth, Shock and Vibration, 10, 51, (2003).
22. T.J. Holmquist, and G.R. Johnson, Journal of Applied Physics, 91(9), 5858, (2002).
23. G.R. Johnson, and T.J. Holmquist, Journal of Applied Physics, 85(12), 8060, (1999).
24. D.S. Cronin, K. Bui, C. Kaufmann, G. McIntosh, and T. Berstad, Proceedings of the 4<sup>th</sup> European LS-Dyna User Conference, D-I-47~60, Ulm, Germany, 2003.
25. C.F. Yen, Proceedings of the 7<sup>th</sup> International LS-DYNA Users Conference, 6-15~23, 2002.
26. R. Zaera, S. Sanchez-Saez, J.L. Perez-Castellanos, and C. Navarro, Composites A: Applied Science and Manufacturing, 31, 823, (2000).