



NAVAL POSTGRADUATE SCHOOL

MONTEREY, CALIFORNIA

MBA PROFESSIONAL REPORT

**Rapid Execution of An Analysis of Alternatives for NATO Special
Operations HQ: A Smart Defence Approach**

**By: Marcos A. Cervantes
Christopher K. Enderton
Joshua S. Powers
December 2012**

**Advisors: Keenan Yoho,
Leo Blanken**

Approved for public release; distribution is unlimited

THIS PAGE INTENTIONALLY LEFT BLANK

REPORT DOCUMENTATION PAGE			<i>Form Approved OMB No. 0704-0188</i>
Public reporting burden for this collection of information is estimated to average 1 hour per response, including the time for reviewing instruction, searching existing data sources, gathering and maintaining the data needed, and completing and reviewing the collection of information. Send comments regarding this burden estimate or any other aspect of this collection of information, including suggestions for reducing this burden, to Washington headquarters Services, Directorate for Information Operations and Reports, 1215 Jefferson Davis Highway, Suite 1204, Arlington, VA 22202-4302, and to the Office of Management and Budget, Paperwork Reduction Project (0704-0188) Washington DC 20503.			
1. AGENCY USE ONLY (Leave blank)	2. REPORT DATE December 2012	3. REPORT TYPE AND DATES COVERED MBA Professional Report	
4. TITLE AND SUBTITLE Rapid Execution of an Analysis of Alternatives for NATO Special Operations HQ: A Smart Defence Approach		5. FUNDING NUMBERS	
6. AUTHOR(S) Marcos A. Cervantes, Christopher Enderton, Joshua S. Powers		8. PERFORMING ORGANIZATION REPORT NUMBER	
7. PERFORMING ORGANIZATION NAME(S) AND ADDRESS(ES) Naval Postgraduate School Monterey, CA 93943-5000		10. SPONSORING/MONITORING AGENCY REPORT NUMBER	
9. SPONSORING /MONITORING AGENCY NAME(S) AND ADDRESS(ES) ARP		11. SUPPLEMENTARY NOTES The views expressed in this thesis are those of the author and do not reflect the official policy or position of the Department of Defense or the U.S. Government. IRB Protocol number _____N/A_____.	
12a. DISTRIBUTION / AVAILABILITY STATEMENT Approved for public release; distribution is unlimited		12b. DISTRIBUTION CODE	
13. ABSTRACT (maximum 200 words) NATO Special Operations Headquarters (NSHQ) determined a need for an air wing after years of conducting operations in Afghanistan. Air enablers are critical to Special Operations Force's combat effectiveness. This capability is not assembled overnight, and training and equipment are vital to mission success. Under the new national strategy for a Smart Defense approach, a Rapid Analysis of Alternatives is needed to find the best way to establish an NSHQ Air Wing. In order to pursue a Smart Defense approach, the U.S. strategy needs to provide a short-term plan for rapid implementation. As the framework nation for the NSHQ, the U.S. would bear much of the economic burden for developing this capability. The most cost-effective approach to this strategy is to employ Excess Defense Articles for immediate use in NATO. The retiring CH-47D and UH-60L aircraft are proven capabilities still being used in Afghanistan and provide a stop-gap solution with low cost to the U.S. This solution provides an immediate capability to support NSHQ and provides time for member nations to begin training while working through political issues. In the long term, this strategy alleviates the U.S.'s cost burden and allows NATO to have a larger role in future conflicts.			
14. SUBJECT TERMS Analysis of Alternatives for rapid acquisition using Excess Defense Articles		15. NUMBER OF PAGES 113	
		16. PRICE CODE	
17. SECURITY CLASSIFICATION OF REPORT Unclassified	18. SECURITY CLASSIFICATION OF THIS PAGE Unclassified	19. SECURITY CLASSIFICATION OF ABSTRACT Unclassified	20. LIMITATION OF ABSTRACT UU

THIS PAGE INTENTIONALLY LEFT BLANK

Approved for public release; distribution is unlimited

**RAPID EXECUTION OF AN ANALYSIS OF ALTERNATIVES FOR NATO
SPECIAL OPERATIONS HQ: A SMART DEFENCE APPROACH**

Marcos A. Cervantes
Major, United States Army
B.A., The Citadel, 2000

Christopher K. Enderton
Major, United States Army
B.S., University of Washington, 1998

Joshua S. Powers
Major, United States Army
B.S., United States Military Academy, 2002

MASTER OF BUSINESS ADMINISTRATION

from the

**NAVAL POSTGRADUATE SCHOOL
December 2012**

Authors:

Marco A. Cervantes

Christopher K. Enderton

Joshua S. Powers

Approved by:

Keenan Yoho, Lead Advisor

Leo Blanken, Support Advisor

William R. Gates, Dean
Graduate School of Business and Public Policy

THIS PAGE INTENTIONALLY LEFT BLANK

RAPID EXECUTION OF AN ANALYSIS OF ALTERNATIVES FOR NATO SPECIAL OPERATIONS HQ: A SMART DEFENCE APPROACH

ABSTRACT

NATO Special Operations Headquarters (NSHQ) determined a need for an air wing after years of conducting operations in Afghanistan. Air enablers are critical to Special Operations Force's combat effectiveness. This capability is not assembled overnight, and training and equipment are vital to mission success. Under the new national strategy for a Smart Defense approach, a Rapid Analysis of Alternatives is needed to find the best way to establish an NSHQ Air Wing.

In order to pursue a Smart Defense approach, the U.S. strategy needs to provide a short-term plan for rapid implementation. As the framework nation for the NSHQ, the U.S. would bear much of the economic burden for developing this capability. The most cost-effective approach to this strategy is to employ Excess Defense Articles for immediate use in NATO. The retiring CH-47D and UH-60L aircraft are proven capabilities still being used in Afghanistan and provide a stop-gap solution with low cost to the U.S. This solution provides an immediate capability to support NSHQ and provides time for member nations to begin training while working through political issues. In the long term, this strategy alleviates the U.S.'s cost burden and allows NATO to have a larger role in future conflicts.

THIS PAGE INTENTIONALLY LEFT BLANK

TABLE OF CONTENTS

I.	INTRODUCTION.....	1
II.	BACKGROUND	5
III.	LITERATURE REVIEW	7
IV.	CH-47 CHINOOK HELICOPTER.....	9
V.	UH-60 BLACK HAWK HELICOPTER	17
VI.	OTHER ALTERNATIVES	25
	A. ALTERNATIVE NAVY SH-60F.....	26
	B. ALTERNATIVE LEASE	29
	C. ALTERNATIVE TASK	30
VII.	NSHQ PROJECT MANAGEMENT:	33
VIII.	SUSTAINMENT	39
IX.	RECOMMENDATIONS.....	51
APPENDIX A:	DIVESTITURE.....	53
APPENDIX B:	TASM-E INFORMATION AND CAPABILITIES	59
APPENDIX C:	AGSE AND PGSE EQUIPMENT DESCRIPTION	67
	LIST OF REFERENCES.....	89
	INITIAL DISTRIBUTION LIST	93

THIS PAGE INTENTIONALLY LEFT BLANK

LIST OF FIGURES

Figure 1.	CH-47 Illustration (U.S. Army, n.d.a)	9
Figure 2.	CH-47 Conducting Sling Load Operations (From U.S. Army, n.d.a)	10
Figure 3.	CH-47 Operating in Afghanistan (From U.S. Army, n.d.a)	10
Figure 4.	CH-47 Military Users (Cargo Helicopters Project Management Office, 2012)	12
Figure 5.	UH-60 Illustration (U.S. Army, n.d.b).....	17
Figure 6.	UH-60 Operating in Support of OIF (From U.S. Army, n.d.b.)	18
Figure 7.	UH-60 Formation Flight (From U.S. Army, n.d.b.)	18
Figure 8.	UH-60 Availability (Utility Helicopters Project Management Office, 2012)	20
Figure 9.	UH-60 Military Users Worldwide (Utility Helicopters Project Management Office, 2012)	20
Figure 10.	SH60 Picture (From U.S. Navy, n.d.).....	27
Figure 11.	SH-60 conducting operations (From U.S. Navy, n.d.).....	29
Figure 12.	AGSE Requirements for TASM–E Support	42
Figure 13.	Army Aircraft Divestiture Screening Process (Utility Helicopters Project Management Office, 2012)	57
Figure 14.	Crane Wheel MTD: Hydraulic Light 7-1/2 Ton With Cab (Chief, TASM-E, personal communication, April 18, 2012).....	69
Figure 15.	Electronic Test Set: TS-4348/UV (Chief, TASM-E, personal communication, April 18, 2012).....	70
Figure 16.	Generic: Aircraft Nitrogen Generator (GANG).....	71
Figure 17.	Kit Air Transportability: UH-60A [PGSE Item] (Chief, TASM-E, personal communication, April 18, 2012).....	72
Figure 18.	Jack ACFT Landing Gear: 5 T 5-1/2 IN MIN H 17-1/2 IN MAX EXT H (Aviation Ground Support Equipment Product Management Office, <i>AGSE Product List</i> , 2012)	73
Figure 19.	Jack Hydraulic Hand: 10 Ton Self-Contained (Aviation Ground Support Equipment Product Management Office, <i>AGSE Product List</i> , 2012)	74
Figure 20.	Jack Hydraulic Tripod: 3 Ton Capacity (Aviation Ground Support Equipment Product Management Office, <i>AGSE Product List</i> , 2012)	75
Figure 21.	Jack Hydraulic Tripod: 5 Ton Capacity (Aviation Ground Support Equipment Product Management Office, <i>AGSE Product List</i> , 2012)	76
Figure 22.	Maintenance Platform: Hydraulic Adjustable Type, 3 to 7 Ft. (B1 & B4) (Aviation Ground Support Equipment Product Management Office, <i>AGSE Product List</i> , 2012)	77
Figure 23.	Power Unit Auxiliary: Aviation Multi-Output GTED (AGPU) (Aviation Ground Support Equipment Product Management Office, <i>AGSE Product List</i> , 2012)	78
Figure 24.	Shop Equipment Contact Maintenance (SECM): Aviation (Shelter Only—Non-Modernized) (Aviation Ground Support Equipment Product Management Office, <i>AGSE Product List</i> , 2012)	79

Figure 25.	Tester: Pitot and Static Systems TS-4463/P (Aviation Ground Support Equipment Product Management Office, <i>AGSE Product List</i> , 2012)	80
Figure 26.	Test Set: Aviation Vibration Analyzer (AVA) (Aviation Ground Support Equipment Product Management Office, <i>AGSE Product List</i> , 2012)	81
Figure 27.	Tool Set: Aviation Foot Locker—Man Portable SPT PM ACFT (Aviation Ground Support Equipment Product Management Office, <i>AGSE Product List</i> , 2012)	82
Figure 28.	Unit Maintenance Aerial Recovery Kit (UMARK) (Aviation Ground Support Equipment Product Management Office, <i>AGSE Product List</i> , 2012)	83
Figure 29.	Test Set ACFT Fuel Quantity Gauge and Indicator: Portable (Aviation Ground Support Equipment Product Management Office, <i>AGSE Product List</i> , 2012)	84
Figure 30.	Towbar Motor Vehicle: Wheeled Vehicle (Aviation Ground Support Equipment Product Management Office, <i>AGSE Product List</i> , 2012)	85
Figure 31.	Tractor Wheeled Aircraft Towing: Gas Operated (Aviation Ground Support Equipment Product Management Office, <i>AGSE Product List</i> , 2012)	86
Figure 32.	Trailer ACFT Main Airmobile: 4 Wheeled 30/48 In. TRF Rail System (Chief, TASM-E, personal communication, April 18, 2012)	87

LIST OF TABLES

Table 1.	Minimum Requirements for NSHQ Aviation.....	2
Table 2.	The Basic Aircraft Capabilities for the CH-47 Chinook (U.S. Army, n.d.a)...	11
Table 3.	Snapshot of Total Cost Estimates for NSHQ to Operate up to 15 CH-47D, Less Fuel Costs	16
Table 4.	The Basic Aircraft Capabilities for the UH-60 Black Hawk (U.S. Army, n.d.b)	19
Table 5.	Snapshot of Total Cost Estimates for NSHQ to Operate up to 15 UH-60, Less Fuel Costs	23
Table 6.	Estimated Delivery Schedule (Deputy Program Manager, Naval Air Systems Command, PMA-299, SH-60 Program Office, personal communication, March 2, 2012).....	27
Table 7.	Estimated Cost Summary (Deputy Program Manager, Naval Air Systems Command, PMA-299, SH-60 Program Office, personal communication, March 2, 2012).....	28
Table 8.	Estimated Cost Summary (Deputy Program Manager, Naval Air Systems Command, PMA-299, SH-60 Program Office, personal communication, March 2, 2012).....	28
Table 9.	Recommended Push Packet Parts for Initial Sustainment (CH-47) (U.S. Army, 2012).....	44
Table 10.	UH-60 Spares Cost Estimates	44
Table 11.	O&M Costs for 5 Periodic/Phase Maintenance Cycles by Aircraft Type (MDS)	48
Table 12.	TASM-E Labor Costs to Support NSHQ Project	48
Table 13.	Life-Cycle Costs by Cost Activity (Less Fuel and Flying Hours).....	49
Table 14.	Aviation Ground Support Equipment and Peculiar Ground Support Equipment.....	68

THIS PAGE INTENTIONALLY LEFT BLANK

LIST OF ACRONYMS AND ABBREVIATIONS

AAO	Army Acquisition Objective
AD	Airworthiness Directive
ADM	Acquisition Decision Memorandum
AFMD	Aviation Field Maintenance Directorate
AGE	Aviation Ground Equipment
AGSE	Aviation Ground Support Equipment
AMARC	Aerospace Maintenance and Regeneration Center
AMCOM	Army Aviation and Missile Command
AO	Area of Operations
AoA	Analysis of Alternatives
APB	Acquisition Program Baseline
ARC	Aircraft Repair Cost
ATTC	Aviation Technical Test Center
BCT	Brigade Combat Teams
CAB	Combat Aviation Brigade
CCAD	Corpus Christi Army Depot
CLS	Contract Logistic Support
COR	Contracting Officer's Representative
CSP	Concurrent Support Package
DA	Direct Action
DASACE	Deputy Assistant Secretary of the Army for Cost and Economics
DISAM	Defense Institute of Security Assistance Management
DoD	Department of Defense
DoS	Department of State
DSCA	Defense Security Cooperation Agency
EDA	Excess Defense Articles
FAA	Foreign Assistance Act
FMS	Foreign Military Sales
FRC	Fleet Readiness Center
FUE	First Unit Equipped

FY	Fiscal Year
GFE	Government-Furnished Equipment
GFP	Government-Furnished Property
GSA	General Services Administration
ICH	Improved Cargo Helicopter
IOC	Initial Operational Capability
ISAF	International Security Assistance Forces
ISTAR	Intelligence, Surveillance, Target Acquisition, and Reconnaissance
IT	Information Technology
JCIDS	Joint Capabilities Integration Development System
LZ	Landing Zone
MA	Military Assistance
MAP	Military Assistance Program
MDA	Milestone Decision Authority
MDD	Materiel Development Decision
MDS	Military Density System
MIPR	Military Interdepartmental Purchase Request
MTOE	Modified Table of Organization and Equipment
MY	Man-Years
NAMA	NATO Airlift Management Agency
NAPMA	NATO A&EWC Program Management Agency
NATO	North Atlantic Treaty Organization
NSHQ	NATO Special Operations Headquarters
NSS	National Security Systems
OEF	Operation Enduring Freedom
OGA	Other Government Agencies
OIF	Operations Iraqi Freedom
OPTEMPO	Operational Tempo
OPLAN	Operational Plan
OPM-SANG	Office of the Program Manager, Saudi Arabia National Guard Modernization Program
PEO	Program Executive Office

PM	Program Manager
PMO	Program Management Office
POR	Program of Record
PP	Push Packages
PWS	Performance Work Statements
QAR	Quality Assurance Representative
RAB	Regionally Aligned Brigades
SAC	Sikorsky Aircraft Company
SACEUR	Supreme Allied Commander Europe
SHAPE	Supreme Headquarters Allied Powers Europe
SOAR	Special Operations Air Regiment
SOCOM	Special Operations Command
SOF	Special Operations Forces
SOFA	Status of Forces Agreement
SORDAC	Special Operations Research, Development, and Acquisition Center
SR	Special Reconnaissance
TASM-E	Theater Aviation Sustainment Manager–Europe
TDP	Technical Data Package
USAMCOM	United States Army Materiel Command
USAREUR	U.S. Army Europe
USCG	United States Coast Guard
UTTAS	Utility Tactical Transport Aircraft System

THIS PAGE INTENTIONALLY LEFT BLANK

ACKNOWLEDGMENTS

We would like to thank our spouses, Jeannette Cervantes, Angie Enderton, and Meg Powers, as well as our children—Miguel, Marcello, and Melania Cervantes; Kai and Moana Enderton; and Nathan Powers—for their tremendous love, support, and encouragement in our writing of this MBA project. We would like to express our appreciation and thanks for their understanding as we dedicated ourselves to the research involved with this project and asked them to make considerable sacrifices.

We would like to extend our sincere and emotional thanks to Dr. Keenan Yoho. He is an absolutely brilliant leader, professor, and mentor. His involvement in the project ensured its success. We are humbly grateful that he took on our project despite the multitude of tasks he was facing both professionally and personally. We wish the best to him and his family and look forward to how his work will shape the special operations community.

We would also like to thank Dr. Leo Blanken for bringing his knowledge and experience with special operations organizations to bear at the most critical time of this project. The professionalism and skills that he shared with us and other Naval Postgraduate School students exemplifies how this institution continues to be the best for the best.

Additionally, we would like to extend our utmost thanks to those professionals from whom we sought information and collected data. The U.S. Navy, PMA-299, and FRC-SW (North Island) organizations provided essential help as we compared SH-60 platforms to the Army's UH-60. We especially appreciate the assistance from Corpus Christi Army Depot, Theater Aviation Sustainment Manager-Europe of the Army Aviation Field Maintenance Directorate, and Aviation Ground Support Equipment Product Management Office, along with the assistance from the Cargo Helicopters Project Office and Utility Helicopters Project Office. Their dedication to the mission of flying and fixing some of the world's greatest rotorcraft is a testament to the high level of their professionalism and is what ensures the Army Aviation Community is "Above the Best."

THIS PAGE INTENTIONALLY LEFT BLANK

I. INTRODUCTION

NATO Special Operations Forces

In November 2006, the North Atlantic Treaty Organization (NATO) convened the Riga Summit where “heads of State and Government of NATO’s 26 member countries gathered for [only] the eighth time since the end of the Cold War” (NATO, 2007, p. 4). The key take-away from the summit was the establishment of a NATO Special Operations Forces (SOF) component.

NATO Special Operations Headquarters

Mission

The NATO Special Operations Headquarters (NSHQ) is the primary point of development, direction, and coordination for all NATO Special Operations–related activities in order to optimize employment of Special Operations Forces to include providing an operational command capability when directed by Supreme Allied Commander Europe (SACEUR).

As NATO continues combat operations in Afghanistan, the principal lesson to be learned is that “NATO SOF is [currently] unable to support the NATO level of ambition due to the lack of dedicated air assets” (Diwa, 2011). In April 2010, NSHQ made the following statement:

While 25 NATO nations possess standing Special Operations Forces, very few have the ability to tactically project their SOF through organic air mobility. Even fewer have the ability to support SOF with airborne Intelligence, Surveillance, Target Acquisition and Reconnaissance (ISTAR). Relying upon the few NATO Special Air capable nations to fill collective special operations aviation needs has not proven feasible. Reliance on non-dedicated air support, through conventional tasking authority, is equally disadvantageous due to scarcity of resources, lack of a habitual training relationship, and unfamiliarity with the SOF mission. (NATO Special Operations Headquarters, 2010, p. 1)

In March 2011, 30 representatives from 16 nations met to discuss NATO SOF air enabler shortfalls. The decision was made to provide the military committee with options

to ameliorate these shortfalls (Diwa, 2011). The recommendation adopted by the committee was to establish an NSHQ air capability responsible for conducting air warfare training and eventually field a Special Operations Air Task Group (SOATG) when directed. This proposed Air Warfare Center will, when realized, fill a considerable gap by providing interoperability training between partner nations' ground and maritime SOF and their necessary air enablers.

Moving Forward

During the last decade, the U.S. has taken on the burden of fighting terrorism and al-Qaeda on two fronts in Iraq and Afghanistan. These conflicts have taken a toll on our nations' economy and military force.

How does the U.S. military become more efficient and have the same worldwide capabilities in today's challenging economic and military environment (see Table 1)?

Table 1. Minimum Requirements for NSHQ Aviation

Support one of the three, or all of the principal tasks of NATO SOF: special reconnaissance (SR), direct action (DA), and military assistance (MA)
Maintain a habitual relationship with national ground and maritime SOF units for training and operations.
Support SOF principal tasks in all environments: mountain, desert, jungle, urban, or maritime.
Insert or extract up to 16 SOF personnel and their equipment in a low to medium threat environment, using low prominence flight techniques, at day or night, using night vision devices, to a precise location (>100miles from the point of origin), with a time-on-target within ± 1 minute.
Fixed-wing SOATUs conduct landings and takeoffs from short, unimproved airfields, at night, using night vision devices.

In October 2011, Admiral William McRaven, Commander Special Operations Command (SOCOM), sent a letter to the Honorable Leon Panetta, Secretary of Defense, stating the following:

I view this U.S.-led NATO SOF initiative as a U.S. economy of force effort that leverages the unique venue of NATO to effectively and

efficiently enhance the capability, capacity, and interoperability of U.S. and NATO Allied and Partner SOF. It is in essence “smart capability and capacity building” with the SOF from our closest Allied and Partner Nations. The uplift in Allied and Partner SOF capability and capacity generated by this effort has immense applicability to other contemporary challenges beyond the immediacy of Afghanistan that we must capitalize on for the future.

The U.S. military becomes more efficient in today’s challenging environment by empowering our NATO partners to conduct more operations. By providing NSHQ with the UH-60 and CH-47 aircraft, NSHQ can support special operations ground forces with the necessary air enablers needed to ensure mission success.

THIS PAGE INTENTIONALLY LEFT BLANK

II. BACKGROUND

NATO History

The North Atlantic Treaty Organization (NATO) is an intergovernmental military alliance based on the North Atlantic Treaty which was signed on April 4, 1949. The purpose of NATO is to provide a collective defense for the member nations if attacked by a non-member nation. In the beginning, NATO was mostly a political association, but changed with the Korean War into a multinational force. Since becoming a multinational force, NATO has supported operations in Bosnia in the early 1990s and Kosovo in 1999 (“NATO,” n.d.).

The September 2001 attacks were an attack on all member nations for the first time in NATO’s history. This attack led to the formation of the NATO-led International Security Assistance Forces (ISAF) task force in charge of operations in Afghanistan. NATO also provided trainers to Iraq, assisted in counter-piracy operations, and led the enforcement of a no-fly zone in Libya in 2011 (“NATO,” n.d.).

History of U.S. SOF Air

In April 1980, U.S. Special Operations Forces were tasked to rescue 53 U.S. citizens taken hostage at the American Embassy in Tehran, Iran. The infamous rescue operation ended in disaster when a helicopter and C-130 Hercules transport aircraft collided on the Desert One landing site in a remote area of the Iranian desert, resulting in the death of eight U.S. servicemen and considerable political backlash. The lack of training, coordination, and interoperability between the various air and ground units all contributed to this debacle (Joint Chiefs of Staff Commissioned Special Operations Review Group, 1980). From then on, the name *Desert One* has been used as a warning to never again underestimate the complexity of using air assets in special operations. The near-future creation of a NATO SOF Air Wing will provide an organizational vehicle to prevent another notorious Desert One scenario for NATO SOF. Considering the valuable lessons learned from its history, NATO now has the opportunity to set this new air wing up for operational success (Brand, Kraag, Brage, & Rahman, 2012).

Since 1980, the U.S. has spent considerable time and resources developing and training a joint SOF air capability. The result was the formation of the 160th Special Operations Air Regiment (SOAR). When U.S. Special Operations Forces need to get to a high-value target at a precise time and place in any environment, they rely on the 160th. The trustworthiness and reliability of U.S. SOF took over 30 years in the making from operations in Grenada, Panama, Desert Storm, Somalia, and the Balkans; Operation Iraqi Freedom (OIF); and Operation Enduring Freedom (OEF), with its recent culminating success being the capture of Osama Bin Laden in 2011. This capability was not formed overnight and has had its setbacks along the way.

The early setbacks with U.S. SOF were a result of the failure of interoperability between the Joint Forces, Army, Navy, and Air Force. This failure resulted in disaster during Desert One. The challenge facing NATO today far exceeds the challenge to the U.S. SOF forces in 1980. Developing a joint U.S. capability at that time was difficult, but it was not nearly as difficult, in comparison, as developing a combined, multinational joint capability for the common defense of 28 member states.

III. LITERATURE REVIEW

In reviewing sources for this thesis, we did not discover any literature that discussed conducting an AoA using EDA to fulfill an urgent real-time United States/NATO Special Operations Command materiel solution requirement. This thesis outlines the specific courses of action required (Logistical, Financial, Program Management) to attain a Smart Defense approach. The literature that we located only describes the processes that are currently available to identify the materiel need, and the process that is available for when the Department of Defense (DoD) no longer requires materiel: the Joint Capabilities Integration Development System (JCIDS) process Analysis of Alternatives (AoA), Foreign Military Sales Procedures.

The DoD instruction manual on the operation of the Defense Acquisition System provides a framework for the activities involved in identifying capability requirements and translating them into a well-executed acquisition program. The Defense Acquisition System contains five phases and the work of this thesis highlights the activities that are involved in the first phase, Materiel Solution Analysis. The phase begins with a Materiel Development Decision (MDD) review which is the formal entry point into the acquisition process, mandatory for all programs. The Milestone Decision Authority (MDA), the designated individual whom is responsible for the overall program, approves the AoA study guidance; determines the acquisition phase of entry; identifies the initial review milestone; and designates the lead DoD component. The AoA is where the investigation assesses preliminary materiel solutions, identifies key technologies, and estimates life-cycle cost. Specifically, the objective of the AoA is to identify potential materiel solutions, and measure their effectiveness upon the user's needs with a focus on cost, schedule, concept of the operation, and overall risk.

Within *The Management of Security Assistance*, an academic document published by the Defense Institute of Security Assistance Management (DISAM) office, is the most current information available to the DISAM regarding U.S. security cooperation programs (DISAM, 2010). *The Management of Security Assistance* states that EDA is a term applied to U.S. defense articles that are no longer needed by the DoD. Such defense

articles may be made available for sale under the Foreign Military Sales (FMS) program (Arms Export Control Act [AECA], 1976, § 21) or as grant (no cost) transfers to eligible foreign countries under the provisions of section 516 of the Foreign Assistance Act (FAA; 1961). The following definition of EDA is provided in section 644(g) of the FAA, which establishes the guidelines for determining which defense articles, may be treated as excess equipment (Prater, 2010):

EDA means the quantity of defense articles other than construction equipment, including tractors, scrapers, loaders, graders, bulldozers, dump trucks, generators, and compressors, owned by the USG, and not procured in anticipation of military assistance or sales requirements, or pursuant to a military assistance or sales order, which is in excess of the Approved Force Acquisition Objective and Approved Force Retention Stock of all DOD Components at the time such articles are dropped from inventory by the supplying agency for delivery to countries or international organizations under this act. (FAA, 1961, § 9(b))

Prior to executing a Foreign Military Sale, all federal agencies and the states are granted the opportunity to request and receive items before they are made available for sale or grant transfer to foreign countries or international organizations. As defense articles actually become excess, they are screened to determine whether they may be sold to eligible countries through FMS procedures or transferred as grant-provided items under the various provisions of the FAA. This unique materiel identification and course of action development endeavor has never been conducted to fulfill an urgent need for the U.S. Special Operations Command and NATO Special Operations. The information reviewed during this literature review demonstrates that there are many processes in place to formally execute this NATO Smart Defense mission.

IV. CH-47 CHINOOK HELICOPTER

The CH-47 Chinook helicopter is a multi-role, tandem rotor helicopter (see Figure 1). The tandem rotor design eliminates the need for a tail rotor system to provide anti-torque. The Chinook is a versatile heavy-lift transport helicopter. Its primary mission is to move troops, artillery, ammunition, fuel, water, barrier materiel, supplies, and equipment on the battlefield. Its secondary missions include medical evacuation, disaster relief, search and rescue, aircraft recovery, firefighting, parachute drops, heavy construction, and civil development (The Boeing Company, n.d.).

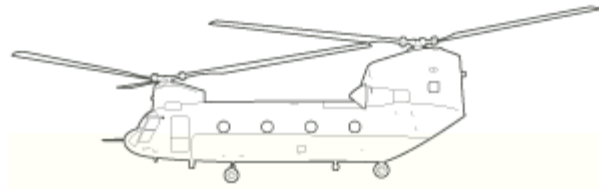

Figure 1. CH-47 Illustration (U.S. Army, n.d.a)

The CH-47 has been in service with the U.S. Army since 1962. The first variants delivered to the U.S. Army were the CH-47A, B, C and all three saw service in the Vietnam War. The CH-47D model was introduced in 1979, began deliveries in 1982, and has been the longest serving Chinook variant in the U.S. Army. CH-47D production ended in 1994 (The Boeing Company, n.d.).

The CH-47 is one of the longest serving aircraft in the DoD, and this represents continuous service by the original airframe itself. The original CH-47A basic airframe delivered to the U.S. Army that flew combat missions in Vietnam is still in service flying combat missions in Afghanistan, as a CH-47D (Marion, 2012). That fact is a true testament to the durability of this aircraft. Figure 2 and Figure 3 show the CH-47 conducting missions. See Table 2 for CH-47 technical data.



Figure 2. CH-47 Conducting Sling Load Operations (From U.S. Army, n.d.a)



Figure 3. CH-47 Operating in Afghanistan (From U.S. Army, n.d.a)

Table 2. The Basic Aircraft Capabilities for the CH-47 Chinook (U.S. Army, n.d.a)

Max Gross Weight	50,000 lbs
Empty Weight	23, 401 lbs
Max Speed	170 knots / 184 mph
Normal Cruise Speed	130 knots / 149 mph
Rate of Climb	1,522 ft/min
Rotor System	three manual-folding blades per hub (two hubs); 225 revolutions per minute; 60 ft rotor span
Troop Capacity	36 (33 troops plus 3 crew members)
Litter Capacity	24
Sling-load Capacity	26,000 lb center hook; 17,000 lb forward/aft hook; 25,000 lb tandem
Minimum Crew	3 (pilot, co-pilot, and flight engineer)

The U.S. Army’s current, modernized variant of the Chinook is the CH-47F that is largely comprised of mainly new-build CH-47F and special operations MH-47G, with some CH-47D conversion aircraft. The CH-47F Improved Cargo Helicopter (ICH) program began in January 1999, with the first production model delivered in June 2006.

Equipment fielding plans originally called for the delivery of 452 CH-47F and 61 MH-47G aircraft. Priority was later given to the MH-47G, and the first example was delivered in January 2005. An initial group of MH-47Gs was deployed to Afghanistan by the 160th SOAR in support of Operation Enduring Freedom in March 2007. Initially, 35 CH-47Ds were updated to MH-47G configuration, and nine MH-47Ds and 17 MH-47Es followed. The last MH-47E to be updated to MH-47G configuration was delivered in 2011 (“CH-47 Helicopter Data,” n.d.). The remaining MH-47G aircraft are to be new build vice updated from existing MH-47E platforms.

The first new-production CH-47F was delivered to the Aviation Technical Test Center (ATTC) at Fort Rucker, Alabama, in November 2007. The first aviation unit delivery of the CH-47F was to the 101st Airborne Division at Fort Campbell, Kentucky, in February 2007 and the 101st achieved the first unit equipped (FUE) milestone that June. The CH-47F’s first deployment to combat with conventional aviation forces was

with aircraft assigned to the 4th Combat Aviation in June 2008 in Iraq (Department of Defense [DoD], 2011a).

Production plans for the CH-47F are continually revised based on Army requirements adjustment and attrite aircraft. However, current published guidance for the Army Acquisition Objective (AAO) is 464 CH-47F based on the Army Transformation Guidance, 246 being remanufactured and 218 new build. The AAO number was previously as high as 533 aircraft. Upon achieving its full production rate, Boeing will deliver 36 aircraft annually and the last deliveries will occur in 2019 (Marion, 2012).

The arrival at or above the AAO requires the divestiture of potentially 100 aircraft. The aircraft identified for retirement will be CH-47D variants. The CH-47D aircraft is operated by over 20 countries worldwide, including eight NATO countries plus Australia (Marion, 2012). This aircraft is the workhorse of NATO, which makes the CH-47D an attractive option to source NSHQ. See Figure 4 for the distribution of CH-47 aircraft worldwide (military users only).

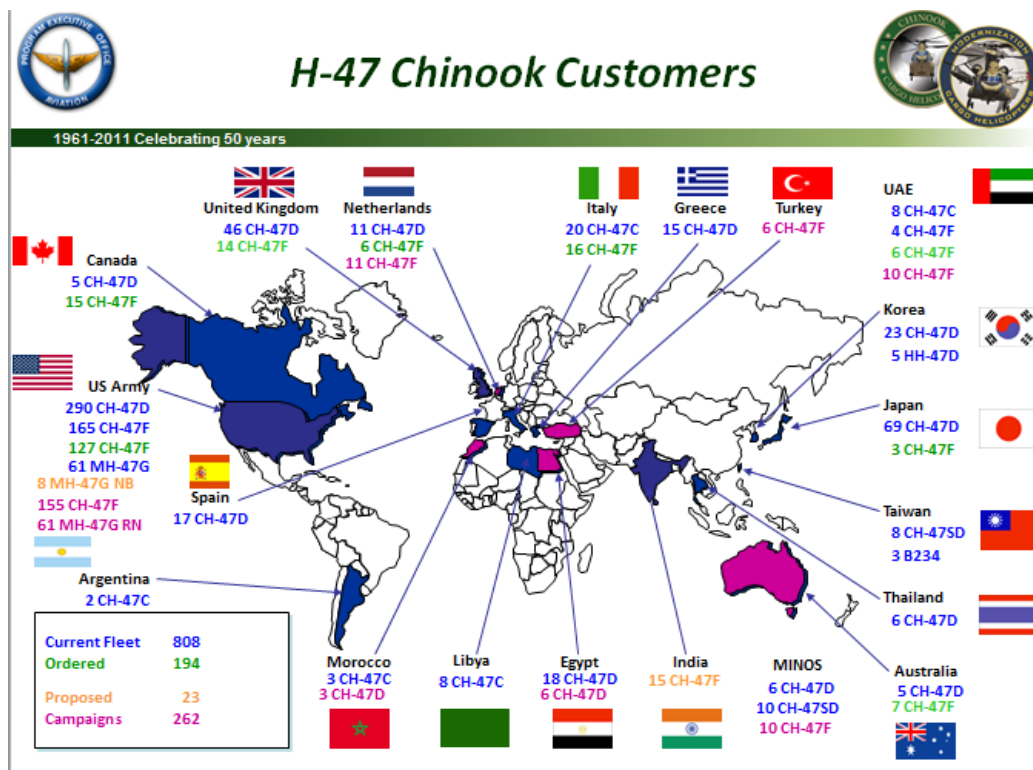

Figure 4. CH-47 Military Users (Cargo Helicopters Project Management Office, 2012)

The retirement population of CH-47D aircraft has 7,105 mean flight hours per airframe. The U.S. Army plans to be fully divested of these aircraft by 2019. The potential retirement schedule by fiscal year (FY), showing how many aircraft will be divested each FY, is as follows (Cargo Helicopters Project Management Office, 2012):

- FY2014: 26 aircraft
- FY 2015: 24 aircraft
- FY2016: 6 aircraft
- FY2017: 15 aircraft
- FY2018: 15 aircraft

Full recapitalization of the aircraft costs potentially \$11 million, with reset costs of \$2–3 million. Recapitalization brings the aircraft to a “zero time” airframe, whereas reset represents deep-cycle maintenance in which major components are fully repaired or replaced (Cervantes, Enderton, & Powers, 2012). Should Project Manager (PM) Cargo or the Army be unable to sell, transfer, or donate the CH-47D aircraft population, the PM will have to fund the disposal. Disposal for the CH-47D requires demilitarization. The cost to demilitarize an aircraft is approximately \$600,000 (Cargo Helicopters Project Management Office, 2012). With potentially 100 CH-47D aircraft to retire, the total cost to demilitarize could be as high as \$60 million.

The cost avoidance measure employed by the PM is to sell the aircraft via FMS, or to transfer to other DoD, other government agencies (OGAs), or other eligible and qualified activities or agencies, in accordance with regulations and applicable law. The sale price of these aircraft as per the PM is roughly \$5 million; the cost for new CH-47D is estimated at \$30–33 million based on recent FMS cases. Any sale via FMS carries a 3.8% surcharge. Funds from the sale are returned to the U.S. Treasury and none will go to the PM (Defense Security Cooperation Agency [DSCA], 2012). Therefore, funds from sales cannot offset the cost of demilitarization or fund the production of CH-47F aircraft.

The ability to transfer CH-47D aircraft from the PM to NSHQ via the U.S. framework organization is a potential win–win situation for both organizations. The PM would be able to avoid costs of demilitarization and NSHQ would be able to receive aircraft for no cost, as far as the initial acquisition. The initial costs for NSHQ would be

the transportation costs associated with relocating aircraft, along with the set-up costs for sustainment (see Chapter VIII: Sustainment).

The cost of transportation can be significantly reduced if conducting the transfer of aircraft in Europe vice relocating aircraft from CONUS locations. This would be possible by coordinating with the PM office to have aircraft transferred from units rotating from Operation Enduring Freedom (OEF). The aircraft can be reset as per Army requirements for redeploying aircraft in Germany at the Theater Aviation Sustainment Manager—Europe (TASM–E) vice other U.S. Army Materiel Command—Aviation Field Maintenance Directorate (USAMCOM–AFMD) sites in CONUS. This strategy would work for units that have CH-47D and are scheduled for CH-47F fielding upon return from deployment.

This cost savings strategy may not work for a whole fleet fielding; however, it may work for an aircraft distribution cascade plan. These opportunities and specific details must be coordinated between the PM office, USAMCOM–AFMD, TASM–E, and NSHQ. Transportation costs could perhaps be absorbed by the NATO alliance should they employ the services of the NATO Heavy Airlift Squadron operating from Papa, Hungary.

The sustainment costs to support CH-47D aircraft were estimated using spares and components lists furnished by the PM office that were built on historical data and fairly rigorous analysis. While these cost estimates present a total cost of ownership, less fuel and other associated costs, there is cause for concern due to the expiration of many spares contracts that will not be renewed by the U.S. Army, or likely the DoD, for CH-47D-peculiar parts. Because the CH-47F is now the configuration/variant for the Cargo Helicopter Program of Record (POR), all spares contracts will focus on that aircraft. However, if there are spares that have CH-47D/F utility, then NSHQ could continue to be a consumer of the spares program of the U.S. Army.

By 2018, it is anticipated that there will be no CH-47D-peculiar parts within the U.S. Army and DoD supply system. Therefore, support for those parts will have to come from the Original Equipment Manufacturer (OEM; Boeing) directly, or secondary sources of supply in the commercial market place. It is likely that Boeing would continue

to supply CH-47D-peculiar parts, since there are many FMS customers and other countries that fly the CH-47D, as well as commercial operators of the aircraft in the United States and internationally (U.S. Army, Cargo Helicopters Project Management Office, 2012).

Table 3. Snapshot of Total Cost Estimates for NSHQ to Operate up to 15 CH-47D, Less Fuel Costs

Cost Activity	Amount	BY2013	FY2014	FY2015	FY2016	FY2017	FY2018	FY2019	TOTAL
Maintenance and Spares (CH-47)									
2 YR CSP for up to 12 aircraft (1 Chinook Flight Company)	\$9,616,942.62	\$9,616,942.62		\$10,262,133.68		\$10,950,609.97		\$11,685,275.44	\$42,514,961.72
5 YR CSP for up to 12 aircraft (1 Chinook Flight Company)	\$17,844,232.97	\$17,844,232.97				\$20,989,374.30			
Initial Spares PP per aircraft	\$2,704,306.00	\$2,704,306.00				\$3,180,954.37			
Per Aircraft (CH-47) CSP & PP TOTAL based on 5 YR	\$20,548,538.97	\$20,548,538.97				\$24,170,328.67			\$44,718,867.64
Per fleet of 15 Aircraft (CH-47), BY2013									
2 YR CSP plus up 25% to 15 Aircraft	\$12,021,178.28	\$12,021,178.28				\$14,139,975.12			
5 YR CSP plus up 25% to 15 Aircraft	\$22,305,291.21	\$22,305,291.21				\$26,236,717.87			
	\$34,326,469.49	\$34,326,469.49				\$40,376,692.99			\$40,376,692.99
		Per Aircraft, BY 2013							
Maintenance Spares (after turn-in credits applied)	\$1,042,891.00	\$1,042,891.00	\$1,077,306.40	\$1,112,857.51	\$1,149,581.81	\$1,187,518.01	\$1,226,706.11	\$1,267,187.41	\$7,021,157.26
Maintenance Labor (Burdened)	\$552,908.55	\$552,908.55	\$571,154.53	\$590,002.63	\$609,472.72	\$629,585.32	\$650,361.63	\$671,823.57	\$3,722,400.40
Maintenance and Spares TOTAL	\$1,595,799.55	\$1,595,799.55	\$1,648,460.94	\$1,702,860.15	\$1,759,054.53	\$1,817,103.33	\$1,877,067.74	\$1,939,010.98	\$10,743,557.66
		Per fleet of 15 Aircraft, BY2013							
		\$15,643,365.00	\$16,159,596.05	\$16,692,862.71	\$17,243,727.18	\$17,812,770.18	\$18,400,591.60	\$19,007,811.12	\$105,317,358.84
		\$8,293,628.25	\$8,567,317.98	\$8,850,039.48	\$9,142,090.78	\$9,443,779.77	\$9,755,424.51	\$10,077,353.52	\$55,836,006.03
		\$23,936,993.25	\$24,726,914.03	\$25,542,902.19	\$26,385,817.96	\$27,256,549.96	\$28,156,016.10	\$29,085,164.64	\$161,153,364.87

V. UH-60 BLACK HAWK HELICOPTER

The UH-60 Black Hawk helicopter is a four-bladed, twin-engine, medium-lift helicopter (see Figure 5). Its primary mission is to provide air mobile assault; general support; aero-medical evacuation; command and control; and special operations support to combat and stability operations. Its secondary missions include disaster relief, search and rescue, firefighting, parachute drops, construction, and civil development (Sikorsky Aircraft Corporation, n.d.).

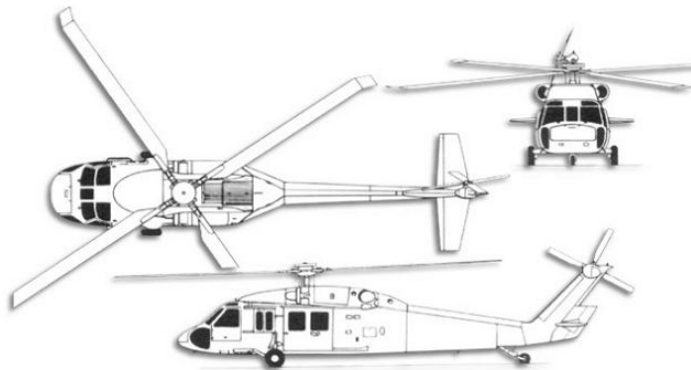

Figure 5. UH-60 Illustration (U.S. Army, n.d.b)

The UH-60 Black Hawk is a utility tactical transport helicopter that replaces the UH-1 *Huey*. The versatile Black Hawk has enhanced the overall mobility of the Army, due to dramatic improvements in troop capacity and cargo lift capability, and will serve as the Army's utility helicopter in the Objective Force. On the asymmetric battlefield, the Black Hawk provides the commander the agility to get to the fight quicker and to mass effects throughout the battle space across the full spectrum of conflict. An entire 11-person, fully equipped infantry squad can be lifted in a single Black Hawk, transported faster than in predecessor systems, in most weather conditions. The Black Hawk can reposition a 105 mm Howitzer and its crew of six, and lift up to 30 rounds of ammunition in a single lift. The aircraft's critical components and systems are armored or redundant, and its airframe is designed to progressively crush on impact to protect the crew and passengers (U.S. Army, n.d.b). See Figures 6 and 7 for images of the UH-60, and Table 4 for UH-60 technical data.



Figure 6. UH-60 Operating in Support of OIF (From U.S. Army, n.d.b.)



Figure 7. UH-60 Formation Flight (From U.S. Army, n.d.b.)

Table 4. The Basic Aircraft Capabilities for the UH-60 Black Hawk (U.S. Army, n.d.b)

	UH-60A	UH-60L
Max. Gross Weight	20,250 lbs	22,000 lbs, 23,500 (external cargo)
Cruising Speed	139 kt	150kt
Endurance	2.3 hrs	2.1 hrs
Range	320 nm	306 nm
Max. Gross Weight	8000 lbs	9000 lbs
Internal Load	2640 lbs (or 11 combat-equipped troops)	
Crew	4 (2 pilots; 2 crew chiefs)	
Armament	Two 7.62mm machine guns	

The programmatic history of the Black Hawk begins when the UH-60A was declared the winner of the U.S. Army Utility Tactical Transport Aircraft System (UTTAS) competition against Boeing Vertol YUH-61A on December 23, 1976. The first flight of the first of three UH-60A competitive prototypes was on October 17, 1974, and the first production flight was exactly four years later in 1978. The 2,000th H-60 was delivered in May 1994; the 2,500th H-60 followed at the end of 2001 (“UH-60 Helicopter Data,” n.d.).

The most current programmatic information on this Program of Record is contained in a December 2011 Selected Acquisition Report (DoD, 2011b): In March 2011, the Program Office and the Deputy Assistant Secretary of the Army for Cost and Economics (DASACE) agreed on an Army Cost Position. On June 20, 2011, the Defense Acquisition Executive approved the UH-60M Black Hawk Acquisition Program Baseline (APB) completing the Acquisition Decision Memorandum (ADM) to rebase line. The five-year Multi-Year VIII (FY2012–FY2016) proposal evaluation/negotiation is now ongoing with a projected award in July 2012. From January 2011 through December 2011, Sikorsky Aircraft Company (SAC) delivered 92 aircraft to the Army. The Army will be fielding five complete H-60M fielding packages to the 82nd Combat Aviation Brigade (CAB), Ft. Bragg, North Carolina, and the 101st CAB, Ft. Campbell, Kentucky. There are no significant software-related issues with this program at this time (DoD, 2011b).

The PM office has identified a total of 728 UH-60A/L models that will be available for military sales beginning in 2014 as a result of the new UH-60M models (see Figure 8).

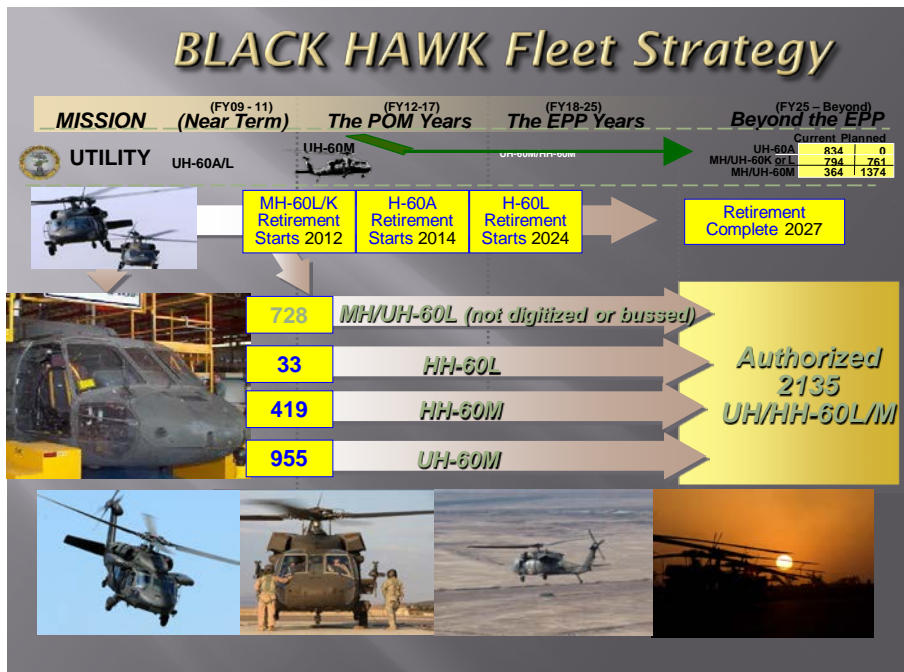

Figure 8. UH-60 Availability (Utility Helicopters Project Management Office, 2012)

Additionally, the UH-60 is currently being operated by NATO and non-NATO countries around the world. See Figure 9 for UH-60 aircraft in use worldwide (military users only).

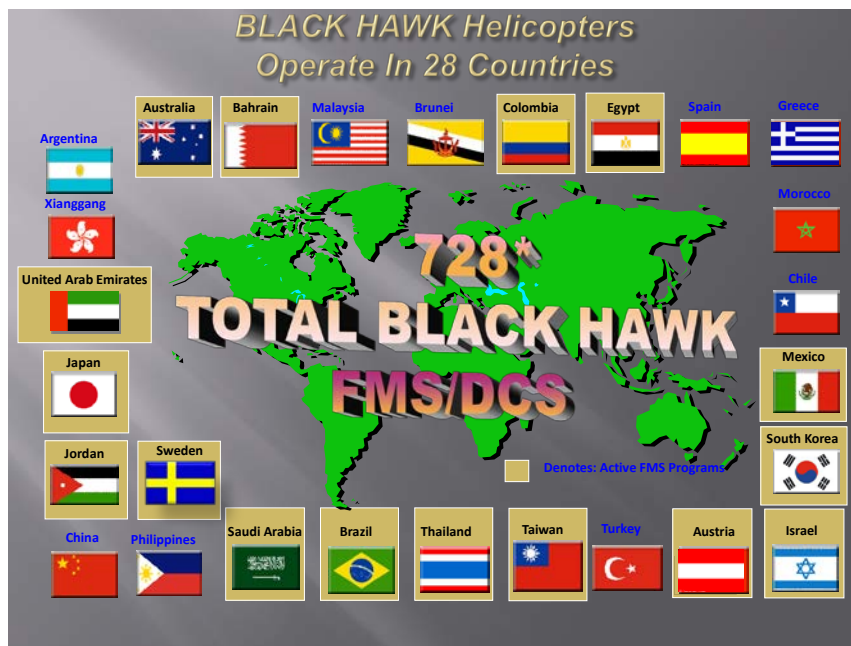

Figure 9. UH-60 Military Users Worldwide (Utility Helicopters Project Management Office, 2012)

Full recapitalization of the UH-60A/L model costs potentially \$5 million. Recapitalization brings the aircraft to a zero time airframe, whereas reset represents deep-cycle maintenance in which major components are fully repaired or replaced (Production Analyst, Corpus Christi Army Depot, personal communication, March 13, 2012).

The cost avoidance measure employed by the PM is to sell the aircraft via FMS, or to transfer to other DoD agencies, OGA, or other eligible and qualified activities or agencies, in accordance with regulations and applicable law. Any sale via FMS carries a 3.8% surcharge. Funds from the sale are returned to the U.S. Treasury, and none will go to the PM (DSCA, 2012). Therefore, funds from sales cannot offset the cost of demilitarization or fund the production of UH-60.

The ability to transfer UH-60 aircraft from the PM to NSHQ via the U.S. framework organization is a potential win-win situation for both organizations. The PM would be able to avoid costs of demilitarization and NSHQ would be able to receive aircraft for no cost, as far as the initial acquisition. The initial costs for NSHQ would be the transportation costs associated with relocating aircraft, along with the set-up costs for sustainment (see Chapter VIII: Sustainment).

The cost of transportation can be significantly reduced if conducting the transfer of aircraft in Europe vice relocating aircraft from CONUS locations. This would be possible by coordinating with the PM office to have aircraft transferred from units rotating from OEF. The aircraft can be reset as per Army requirements for redeploying aircraft in Germany at TASM-E vice other USAMCOM-AFMD sites in CONUS. This strategy would work for units that have UH-60A and are scheduled for UH-60 fielding upon return from deployment.

This cost savings strategy may not work for a whole fleet fielding; however, it may work for an aircraft distribution cascade plan. These opportunities and specific details must be coordinated between the PM office, USAMCOM-AFMD, TASM-E, and NSHQ. Transportation costs could perhaps be absorbed by the NATO alliance should they employ the services of NATO.

The sustainment costs to support UH-60 aircraft were estimated using PM office furnished spares and components lists that were built on historical data and fairly rigorous analysis. While these cost estimates present a total cost of ownership, less fuel and other

associated costs, there is cause for concern due to the expiration of many spares contracts that will not be renewed by the U.S. Army, or likely the DoD, for UH-60-peculiar parts. Since UH-60 is now the configuration/variant for the Utility Helicopter Program of Record (POR), all spares contracts will focus on that aircraft. However, if there are spares that have UH-60/F utility, then NSHQ could continue to be a consumer of the spares program of the U.S. Army.

By 2018, it is anticipated that there will be no UH-60-peculiar parts within the U.S. Army and DoD supply system. Therefore, support for those parts will have to come from the OEM (Sikorsky) directly, or secondary sources of supply in the commercial market place. It is likely that Boeing would continue to supply UH-60 peculiar parts, since there are many FMS customers and other countries that fly the UH-60, as well as commercial operators of the aircraft in the United States and internationally.

Table 5. Snapshot of Total Cost Estimates for NSHQ to Operate up to 15 UH-60, Less Fuel Costs

Maintenance and Spares (UH-60)									
2 YR C SP/PP per aircraft (SH-60 data)	\$4,862,186.80	\$4,862,186.80		\$5,188,386.05		\$5,536,469.68		\$5,907,905.90	\$16,632,761.63
Per fleet of 15 Aircraft (UH-60), BY2012	\$14,104,789.16	\$14,104,789.16		\$15,051,065.36		\$16,060,826.28		\$17,138,331.06	\$48,250,222.70
		Per Aircraft, BY 2013							
Maintenance Spares (after turn-in credits applied)	\$669,061.88	\$669,061.88	\$691,140.92	\$713,948.57	\$737,508.88	\$761,846.67	\$786,987.61	\$812,958.20	\$4,504,390.85
Maintenance Labor (Burdened)	\$362,962.38	\$362,962.38	\$374,940.14	\$387,313.16	\$400,094.50	\$413,297.62	\$426,936.44	\$441,025.34	\$2,443,607.19
Maintenance and Spares TOTAL	\$1,032,024.26	\$1,032,024.26	\$1,066,081.06	\$1,101,261.74	\$1,137,603.37	\$1,175,144.28	\$1,213,924.05	\$1,253,983.54	\$6,947,998.04
		Per fleet of 15 Aircraft, BY2013							
		\$10,035,928.20	\$10,367,113.83	\$10,709,228.59	\$11,062,633.13	\$11,427,700.02	\$11,804,814.12	\$12,194,372.99	\$67,565,862.69
		\$5,444,435.70	\$5,624,102.08	\$5,809,697.45	\$6,001,417.46	\$6,199,464.24	\$6,404,046.56	\$6,615,380.09	\$36,654,107.88
		\$15,480,363.90	\$15,991,215.91	\$16,518,926.03	\$17,064,050.59	\$17,627,164.26	\$18,208,860.68	\$18,809,753.09	\$104,219,970.57

THIS PAGE INTENTIONALLY LEFT BLANK

VI. OTHER ALTERNATIVES

Excess defense articles (EDA) provide NSHQ with a rapid and proven capability to stand up NSHQ's air capability. It is important for the United States to deliver a flyable product quickly to its allied NATO partners. If the U.S. waits for the normal acquisition process to work and turns out an optimal solution for NATO SOF, then the buy-in period of member nations will expire. A short-term solution to the overall problem is needed in order to show resolve and commitment as the framework nation for NSHQ. The need to fill the five-year gap between now and the optimal solution is vital to establishing an air capability for NATO SOF. Finding a solution now and empowering our allied partners to take a larger role in global security is Smart Defense.

Using EDA to equip NATO is a solution that would fill the operational need immediately. The Foreign Assistance Act of 1961, the Arms Export Control Act (1976), and 22 U.S.C. § 2321J govern and authorize the use of EDA. Defense articles declared excess by the DoD are authorized for use by allied partners in support of U.S. national security objectives (DSCA, 2008). The U.S.C. authorizes the President of the United States to transfer excess DoD equipment to foreign countries, with NATO being the priority ("Authority to Transfer," 2000).

The use of EDA to support NSHQ will not have to conform to some of the rules regulating foreign military sales. Instead, the U.S. is the framework nation, meaning that the U.S. will still own and maintain the equipment given to NSHQ. Aircraft that are currently destined for the "boneyard" at the Aerospace Maintenance and Regeneration Center (AMARC) can fill NSHQ's requirement now.

Currently, the U.S. Navy has enough SH-60F scheduled to retire through about 2015 to satisfy the full NSHQ requirement of 24 aircraft. These "free" aircraft were offered to meet this mission. In order for these aircraft to fill this need, more analysis of purpose and capability is needed. The cost for phase maintenance, modifications, and sustainment are also important to the discussion of which airframe to use.

A. ALTERNATIVE NAVY SH-60F

SH-60F Multi-Mission Naval Helicopters. These helicopters are being offered as EDA at no cost under Section 516 of the Foreign Assistance Act (FAA) of 1961, as amended. The helicopters will be delivered in “as is, where is” condition. Line item 001 does not include T700-401C engines. Condition code A-4 (serviceable, used–good) applies.

The SH60 presents a good option because they are available immediately, even before the CH-47 or UH-60. Transferring these aircraft to NSHQ’s property book is not a difficult task. However, bringing these aircraft to a mission-capable status may be a considerable task and poses the question of who will manage these aircraft and support them?

The mission needs and capabilities of the global SOF customer is another factor to look at when selecting the SH-60F. The purpose of SOF aviation is to provide support to the SOF soldier on the ground. Lift capability is supposed to get the soldier to an Area of Operations (AO) or to a specific target quickly and safely. One of the limiting factors for the SH-60F is the design of the airframe itself. One factor is the tail wheel which is moved inward from the tail pylon to under the cabin. This design was implemented to allow the aircraft the improved capability to land on Navy ships. However, this design makes it more difficult to operate in desert environments, making the platform less safe for the customer.

The other limiting factor is the right side–only door. This design aspect makes it difficult for a special operations team to exit the aircraft or enter the aircraft quickly on an infiltration or exfiltration. This delay can leave a team vulnerable to enemy fire on a landing zone (LZ). Having only one cargo door also limits the ability of teams to conduct fast rope or HELOCAST operations quickly. The additional time needed to enter and exit the aircraft can leave soldiers and aircrew vulnerable to enemy fire at the most critical stage of an operation. Current special operations officers that have used SH-60F on current operations in Afghanistan have stated that this aircraft is not ideal and is not preferred for conducting DA.

Although the SH-60F is available now to NSHQ, it may not be the five-year solution needed to fill the stop gap. It provides an initial capability, but as the scope of NSHQ SOF Aviation progresses, it may hinder this rapidly growing Smart Defense capability.



Figure 10. SH60 Picture (From U.S. Navy, n.d.)

Table 6. Estimated Delivery Schedule (Deputy Program Manager, Naval Air Systems Command, PMA-299, SH-60 Program Office, personal communication, March 2, 2012)

Calendar Year	2012	2013
Quarter	2-3-4	2-3-4
SH-60F (#)	0-0-2	1-1-2

Table 7. Estimated Cost Summary (Deputy Program Manager, Naval Air Systems Command, PMA-299, SH-60 Program Office, personal communication, March 2, 2012)

Net Estimated Cost	\$98,581,268
Packing, Crating, and Handling	\$0
Administrative Charge	\$3,746,089
Transportation	\$0
Other	\$0
Total Estimated Cost	\$102,327,357

Cost data was obtained for the first six deliverable SH60s

Table 8. Estimated Cost Summary (Deputy Program Manager, Naval Air Systems Command, PMA-299, SH-60 Program Office, personal communication, March 2, 2012)

Labor	\$682,271 (7,826 hours @ \$87.18/hr)
Materiel	\$151,000
Additional Labor	\$65,000
Transportation	\$30,000
Total	\$928,271

The *additional labor* costs are related to organizational level maintenance hours (~750) normally performed by Sailors, including engine run ups, blade removals/reinstallation, servicing, special inspections, and so forth.

The materiel cost listed in Table 8 *does not* include aviation depot-level repairable components that will most likely be required to make the aircraft flight-ready, such as engines, main gearbox, blades, avionics, actuators, and so forth. This could be a considerable additional expense. (For example, the replacement cost for a T700 engine is

~\$690,000 (Deputy Program Manager, Naval Air Systems Command, PMA-299, SH-60 Program Office, personal communication, March 2, 2012)



Figure 11. SH-60 conducting operations (From U.S. Navy, n.d.)

B. ALTERNATIVE LEASE

NATO is currently facing a large problem in Afghanistan due to the lack of helicopters. It does not have the ability to conduct operations without the extensive support of other countries. “It’s not that NATO nations don’t have helicopters. The problem is that they’re very expensive to ship to Afghanistan and to operate/maintain them there,” explained Maj. Gen. Ton van Loon, Commander, NATO Regional Command South (Lok, 2007). A leasing option would serve as a stopgap and does come at a significant cost. This option would enable NSHQ SOF to have consistent aerial support, despite ongoing concerns over fiscal austerity measures and the expense of purchasing new equipment.

Leasing aircraft gives NSHQ a capability now and provides the maintenance team necessary to support operations. Leasing gives NSHQ the flexibility to select an aircraft that is familiar to many of the NATO member nations. Leasing is a cost-effective way to stand up a capability now, and it provides time for the acquisition process to work and to produce the aircraft NSHQ wants and needs for the long term.

The problem with leasing is that it may be difficult to lease a combat aircraft capable of operating in the austere Afghanistan environment. What happens when you take a leased aircraft to combat and you don't bring it home? Combat operations cause significant wear and tear on an aircraft. The missions that NSHQ SOF conduct can expose aircraft to situations that have the potential to destroy an aircraft. If an aircraft is destroyed, then the cost of the total aircraft would have to be paid.

C. ALTERNATIVE TASK

NSHQ seeks consistent operational support from U.S. aviation units on a rotational basis until a materiel solution has been identified. This operational construct would be similar to the way the U.S. Joint Task Force tasks for support from all U.S. Military Services. The U.S. Special Operations Aviation Unit 160th SOAR would be the most likely choice. The 160th is the gold standard for SOF aviation. The success of this unit was 30 years in the making and would be the ideal solution for training member nations on SOF aviation support, but given limited resources and high Operational Tempo (OPTEMPO), conventional army aviation units would be the next target solution. This construct would be followed with other nations that have suitable aviation capabilities and meet the minimum requirements set by NSHQ SOF Aviation.

Currently, with the drawdown in Iraq and the future drawdown in Afghanistan, conventional aviation forces may be available to provide this aviation capability to NSHQ. The new construct of Regionally Aligned Brigades (RAB) provide Combatant Commanders (COCOM) attached Brigade Combat Teams (BCT) which are available for use when needed in their AO. Using this construct, a regionally aligned aviation task force from a Combat Aviation Brigade (CAB) can provide NSHQ with an on-call training or Direct Action capability. Throughout the last 10 years of sustained conflict, conventional aviation forces have gained the experience and expertise necessary to provide this needed capability. This tasking solution is a stop gap until NATO can assume its roll and have the ability to support its SOF with an aviation capability.

THIS PAGE INTENTIONALLY LEFT BLANK

THIS PAGE INTENTIONALLY LEFT BLANK

VII. NSHQ PROJECT MANAGEMENT:

From Acquisition to Life-Cycle Management

The EDA or retiring aircraft solutions provide perhaps the most efficient means to achieve objective ends, certainly in the near term. Acquiring aircraft that would have otherwise become EDA or demilitarized may have an attractive price tag at first. Similar to procuring new aircraft, a buyer purchases or acquires a basic airframe. Mission equipment such as avionics, hoists, and weapons mounts commonly referred to as “B kit” items, must be procured separately. The additional cost of the procurement of engines per airframe plus a few spares must be considered, especially for EDA. Further costs may include rotor blades and possibly transmissions or gearboxes. The requirements vary predicated on the condition of the EDA aircraft offered.

Determining the cost of “free” requires systematic inquiry into the initial procurement of spares, sustainment, and logistic support. This goes beyond simply inspecting airframes. The strategy for initial maintenance must include discussion of whether to pursue complete overhaul or repair and return. A complete overhaul has merit in best offering close to a zero-time aircraft. However, the price is at a premium over repair and return and requires the most time to complete service, potentially up to 350 days. A repair-and-return decision allows the customer to choose the depth of maintenance and the components to repair or replace. Doing such shall reduce considerably the time to complete service, possibly 180 days or less. Therefore, if the goal is to have aircraft available sooner, then a repair-and-return strategy is likely best. If buyers choose to repair and return, they should plan accordingly for the replacement of critical components and inspections along the way, maintenance that might have been delayed if a complete overhaul had been pursued up front.

Life-cycle management begins before the “buy” or initial issue. Procurement follows the planning, provisioning, and determination of stock levels. Determinations are difficult without knowing aircraft disposition and fiscal resources. Buyers should base the decision of where to conduct overhauls and repair and returns on the capacity and capability. The choice of venue may initially be in the United States, such as the Corpus

Christi Army Depot (CCAD) or the Fleet Readiness Center Southwest (FRC Southwest) at Naval Air Station North Island, Coronado. The latter would be a good choice based on an SH-60, the former perhaps better suited for UH-60 and or CH-47. However, CCAD would be capable of servicing the SH-60.

Once aircraft are accepted and relocated to Europe, maintenance service at the organizational (field) and intermediate to depot (support) conducted in region becomes preferable to retrograde back to CONUS. The Theater Aviation Sustainment Manager–Europe, or TASM–E, is a U.S. Army Aviation and Missile Command (AMCOM) activity based in Mannheim, Germany. TASM–E could provide a viable solution to intermediate-to depot-level (support) maintenance. Potential contract vehicles may exist for TASM–E to provide Contract Logistic Support (CLS) for NSHQ Aviation organizational maintenance. Or other contract vehicles may exist under U.S. Army Europe (USAREUR) for these services, similar to those services supporting the CINC Hawks (UH-60) at Supreme Headquarters Allied Powers Europe (SHAPE)/Supreme Allied Commander Europe (SACEUR). Pursuing CLS solutions is consistent with the NSHQ intent of the Special Operations Aviation Tasking Unit (SOATU) and Special Operations Aviation Training Group (SOATG) being manned with aviators and aircrew only.

Considerations for CLS include cost, scope, and resource planning. Clearly defining requirements is paramount to success. It is also important for logistics managers to employ the best practices when developing performance work statements (PWS). Many fine examples exist in the DoD, particularly in Europe. Part of resource planning includes determining how much government-furnished equipment (GFE) or government-furnished property (GFP) a CLS venture may require. GFE is typically tools and aviation ground support equipment (AGSE). GFP is typically facilities, such as hangar or ramp space, and buildings. CLS contracts without any GFE or GFP command higher prices. Additional considerations for CLS are manpower/hiring laws in the host country and any Status of Forces Agreement (SOFA), standard agreements, or treaties.

The use or employment of the services provided by TASM–E reduces the necessity of entering into the procurement of CLS services. TASM–E has existing contract vehicles to provide aircraft maintenance support to the level that NSHQ requires.

To acquire the services of TASM–E, NSHQ through USSOCOM or USAREUR would issue funding to begin the project task order via a Military Interdepartmental Purchase Request (MIPR) on a DD form 448 (DD448). Upon receipt of funds and acceptance via MIPR, TASM–E would then begin to organize and develop the support package.

Planning for life-cycle management is likely beyond the scope of the current organizational structure of NSHQ. Planning and execution of training, operations of core SOF missions (DA, SR, and MA), are core competencies. Program management does not fit the structure of NSHQ; rather, program management would become burdensome for NSHQ if faced with the additional task. Instead, professionals of other organizations, appropriately structured and resourced, should do the program management for NSHQ.

There is precedent to handle program management from within NATO. The NATO A&EWC Program Management Agency (NAPMA; Lok, 2007) and NATO Airlift Management Agency (NAMA; NATO, n.d.) are such examples. However, these programs and assets represent collaborative efforts and resources of alliance members and partners for peace. Whereas, NSHQ is a framework organization in which the establishment of structure and resources are likely required upfront before real collaboration begins. Additionally, should the preponderance of assets be gifted EDA, new procurement, or lease from the United States, then program management of these assets is perhaps best suited for a U.S. Program Management Office (PMO) within the DoD, especially considering that airworthiness directives (ADs) and FAA certification is typically more stringent than any regulatory standards worldwide.

Which service shall provide the PMO? DoD program management is disaggregated by design. Aircraft or the aviation systems determine the organization of a PMO. Specifically, a PMO is established to support a given aircraft or system. While some PMOs are established for a family of vehicles or aircraft, seldom would these offices have the diverse mix of aircraft required by NSHQ. Nor would aircraft PMOs manage the bevy of mission equipment suites, along with AGSE, tools, and avionics, to name a few. These systems are typically managed by separate PMOs specializing in this equipment. Therefore, program management of NSHQ aircraft by a singular agency is likely preferable.

To understand the benefits of dedicated PMOs for NSHQ aircraft, it is important to first understand the great disincentive for program management to be performed by the existing rotary-wing PMOs for SH-60, UH-60, and CH-47, or any fixed-wing aircraft PMO. The disincentive for those entities, first and foremost, is the lack of configuration management. If a PMO is to be burdened with supporting aircraft for spares, life-cycle logistics, and the provision of technical data, then PMOs will want to manage, if not control, the configuration. Configuration of most aircraft, as specified by the technical data package (TDP), is predicated on the original aircraft and mission profile. More important to this discussion of configuration management is that the PMOs no longer retain or provide configuration management for divested aircraft, especially after the transfer to the gaining activity.

Special operations organizations almost always drift from the standard mission profile. Such organizations typically modify structures and surfaces to suit the mission or use aircraft seemingly beyond the performance envelope. More troubling for engineers managing the technical data package is all of the non-standard mission equipment that special operations aviation organizations employ. Therefore, PMOs would have difficulty providing adequate technical support to their special operations customers since the aircraft would differ greatly from the standard configuration employed by the majority of customers.

This great disincentive is ameliorated by having a dedicated PMO for NSHQ. This PMO can be a specially established PMO (purpose built) or an existing one that currently services special and non-standard aircraft. Perhaps the foremost example of a specially established PMO is the Office of the Program Manager, Saudi Arabia National Guard Modernization Program (OPM-SANG; Global Security.org, n.d.). This organization functions as a total acquisition program executive office (PEO) that handles all aspects of providing materiel solutions to the Kingdom of Saudi Arabia, to include life-cycle management thereof.

The non-standard aircraft PMO model would be USSOCOM Special Operations Research, Development, and Acquisition Center (SORDAC) PEO-Rotary Wing. Perhaps program management for NSHQ by this organization is the most sensible

solution. USSOCOM is set to take over executive agent responsibilities from the U.S. Army within the next fiscal year and handle framework functions and funding for NSHQ. SORDAC is clearly agile and adaptive in its acquisition practices, along with being greatly capable of contending with non-standard aircraft and configurations of such aircraft.

The synergy between combat developer/requiring activity and materiel developer would proliferate with NSHQ and SORDAC. This arrangement could potentially streamline the planning and programming of fiscal resources. A greater link between materiel solutions, manning, and strategy would exist. Additionally, this organization is chartered (authorized) to manage above aircraft requirements and also manage the mission equipment, “B kit” items, AGSE, and more. While many PMOs are resourced and capable of performing these functions, few (if any) are chartered to do so.

The final program management solution and life-cycle planning for NSHQ is far from decided. Further research will best determine if any of these ideas are sound and credible as specified and written in this thesis. Having a PMO that is chartered and capable of supporting aircraft, mission equipment, AGSE, and other associated “B kit” items should enhance efficiency, leading to successful life-cycle management. Ultimately, fiscal and policy constraints, participation by the alliance, and other factors apply weight to such decisions.

The U.S. Army’s Non-Standard Rotary Wing Aircraft PMO is not considered here, with the focus instead being on EDA SH-60, UH-60, and CH-47. However, should a decision be made to pursue non-standard aircraft (non-Army or non-DoD), then perhaps this PMO could be considered. Again, the configuration management disincentive may remain.

THIS PAGE INTENTIONALLY LEFT BLANK

VIII. SUSTAINMENT

For the purpose of this research report, sustainment refers to the maintenance of fielded systems and their subsequent life-cycle product support. Life cycle in this situation covers initial procurement (including transfer), supply chain management, and operational maintenance. Sustainment functions include initial provisioning, cataloging, inventory management and warehousing, and field and sustainment (including depot) level maintenance. System sustainment is required when any portion of the planned production or transfer quantity has been fielded for operational use.

Joint Publication 4-0 (*Doctrine for Logistic Support of Joint Operations*) defines sustainment as “The provision of personnel, logistic, and other support required to maintain and prolong operations or combat until successful accomplishment or revision of the mission or the national objective” (Chairman of the Joint Chiefs of Staff [CJCS], 2000). It includes the supplies and services needed to support the initial execution of approved Operational Plans (OPLANs), an intermediate level of supplies to support the force until resupply is available, and the replenishment stocks necessary to maintain and conclude operations. “Theater sustainment management should emphasize velocity and time-definite delivery from CONUS and other sources outside the theater rather than large in-place inventories” (Global Security.org, n.d.-b).

According to Defense Acquisition University (DAU; n.d.), “sustainment includes supply, maintenance, transportation, sustaining engineering, data management, configuration management, manpower, personnel, training, habitability, survivability, environment, safety (including explosives safety), occupational health, protection of critical program information, anti-tamper provisions, and information technology (IT), including National Security Systems (NSS), supportability and interoperability functions.” In addition, according to paragraph 5.4.5 of *Defense Acquisition Guidebook*, Sustainment: Operations and Support (DAU; n.d.),

while acquisition phase activities are critical to designing and implementing a successful and affordable sustainment strategy, the ultimate measure of success is application of that strategy after the system has been deployed for operational use. Total Life Cycle Systems

Management, through single point accountability, and Performance Based Logistics, by designating performance outcomes vs. segmented functional support, enables that objective. Warfighters require operational readiness and operation effectiveness—systems accomplishing their missions in accordance with their design parameters in a mission environment. Systems, regardless of the application of design for supportability, will suffer varying stresses during actual operational deployment and use. (DAU, n.d.)

Cost Categories

The costs associated with the NSHQ Air Wing, helicopter fleet, include aviation ground support equipment (AGSE), initial spares package (also referred to as push packages, or PP), concurrent support package (CSP), operational maintenance (field and sustainment levels), repair parts, and labor. The costs presented in this report represent U.S. government to U.S. government cost and pricing data predicated on the U.S. framework organization for NSHQ. Therefore, no commercial market research was conducted to determine the costs of spares, labor, and AGSE. Fuel and transportation costs, while key cost drivers of operations, were also not included because of both the uncertainty and variability of NSHQ requirements for developing rotary-wing capabilities.

Aviation ground support equipment (AGSE) is also referred to as aviation ground equipment (AGE). The estimated total cost of AGSE to support NSHQ helicopters is \$4.755 million. The equipment costs presented in this research are based on requirements set forth by the Theater Aviation Sustainment Manager–Europe (TASM–E), of the Aviation Field Maintenance Directorate (AFMD), a U.S. Army Aviation and Missile Command (AMCOM) activity. TASM–E guidance was sought out and used because they support U.S. Army aircraft in Europe with sustainment-level maintenance. TASM–E further provides direct aircraft maintenance (field and sustainment level) to the aircraft that support the SHAPE and the command helicopters for SACEUR.

The AGSE component list (see Figure 12) is not fully inclusive of the entire range of U.S. Army or DoD AGSE because TASM–E will not source the same levels of manpower that an aviation battalion of the U.S. Army would have authorized in its Modified Table of Organization and Equipment (MTOE) for similar quantities of aircraft

as NSHQ seeks to acquire. Additionally, TASM-E does source some of its own equipment in support of its customers and maintains this equipment with its direct cite budget. Reimbursable funds to TASM-E supplement maintenance and sustainment of tooling and other physical components at minimal levels and are likely captured in overhead costs.

TASM-E NSHQ Project Task Order
AGSE / PGSE Requirements

ITEM	REFERENCE	LIN	ERC	Nomenclature	QTY	REQ	Unit Cost*	Total Cost
1	TASM Slide 3	C36151	A	CRANE WHEEL MTD: HYDRAULIC LIGHT 7-1/2 TON W/CAB (*)	2		\$58,481.00	\$116,962.00
2	TASM Slide 2	E03826	A	ELECTRONIC TEST SET: TS-4348/UV	1		\$677.32	\$677.32
3	AGSE Slide 14	G90261	A	GENERIC: AIRCRAFT NITROGEN GENERATOR (GANG)	1		\$139,182.12	\$139,182.12
4	TASM Slide 4	K27251	A	KIT AIR TRANSPORTABILITY: UH-60A [PGSE Item]	15		\$0.00	\$0.00
5	AGSE Slide 20	L09135	A	JACK ACFT LANDING GEAR: 5 T 5-1/2 IN MIN H 17-1/2 IN MAX EXT H	4		\$1,302.29	\$5,209.16
6	AGSE Slide 21	L09340	A	JACK HYDRAULIC HAND: 10 TON SELF-CONTAINED	4		\$1,857.13	\$7,428.52
7	AGSE Slide 23	L10532	A	JACK HYDRAULIC TRIPOD: 3 TON CAPACITY	4		\$966.33	\$3,865.32
8	AGSE Slide 24	L10559	A	JACK HYDRAULIC TRIPOD: 5 TON CAPACITY	2		\$4,237.37	\$8,474.74
9	AGSE Slide 10, 11	M02504	A	MAINTENANCE PLATFORM: HYDRAULIC ADJUSTABLE TYPE 3 TO 7 FT H (B1 & B4)	3		\$16,709.13	\$50,127.39
10	AGSE Slide 12	P44627	A	POWER UNIT AUXILIARY: AVIATION MULTI-OUTPUT GTED (AGPU)	3		\$1,204,047.41	\$3,612,142.23
11	AGSE Slide 13	S30224	A	SHOP EQUIPMENT CONTACT MAINTENANCE (SECM): AVIATION (SHELTER ONLY-Nonmodernized)	2		\$10,500.00	\$21,000.00
12	AGSE Slide 8	T03597	A	TESTER: PITOT AND STATIC SYSTEMS-4463/P	2		\$57,405.51	\$114,811.02
13	AGSE Slide 16	T53635	A	TEST SET: AVIATION VIBRATION ANALYZER (AVA)	3		\$33,097.83	\$99,293.49
14	AGSE Slide 18	T65997	A	TOOL SET: AVIATION FOOT LOCKER -MAN PORTABLE SPT PM ACFT	12		\$8,412.58	\$100,950.96
15	AGSE Slide 15	U87773	A	UNIT MAINTENANCE AERIAL RECOVERY KIT: (UMARK)	2		\$153,332.76	\$306,665.52
16	AGSE Slide 9	V77715	A	TEST SET ACFT FUEL QUANTITY GAGE AND INDICATOR: PORTABLE, SUBLIN FG2507	2		\$12,700.72	\$25,401.44
17	AGSE Slide 25	W66528	A	TOWBAR MOTOR VEHICLE: WHEELED VEHICLE, SUBLIN W69391	5		\$1,057.79	\$5,288.95
18	AGSE Slide 4	W88803	A	TRACTOR WHEELED AIRCRAFT TOWING: GAS OP, SUBLIN S21580 SATS (*)	2		\$65,872.39	\$131,744.78
19	TASM Slide 1	W93995	A	TRAILER ACFT MAINT AIRMOBILE: 4 WHEELED 30/48 IN TRF RAIL SYSTEM	2		\$2,852.00	\$5,704.00

Notes:

(*) indicates COTS or GOTS equivalent variant and plus up quantity of 1 above requirement
 [PGSE Item] indicates flyaway kit that should become available with aircraft
 (SHELTER ONLY-Nonmodernized) indicates SECM as shelter only without prime mover integrated system

\$4,754,528.96

Figure 12. AGSE Requirements for TASM-E Support

Note. See Appendix B for reference slides/information on pieces of equipment.

Initial spares or push packages (PP) costs are representative of repair parts that should be stocked at limited quantities to fulfill maintenance requirements. Equipment or parts on this list may represent items with longer lead times and are potentially susceptible to damage or require repair upon scheduled inspections or maintenance, based on historical data. Aircraft Program Management Office and materiel management commands may have different and distinct methodologies for conducting this analysis and some offices do not offer a PP recommendation, rather instituting recommended spares packages based on various aircraft densities.

Initial spares (PP) and concurrent spares packages (CSP) are estimated based on aircraft density, operational tempo, number of operating bases, distance from supply sources, and environmental factors. The lists of PP and CSP items were provided by the CH-47 (PM Cargo) and UH-60 (PM Utility) program management offices. These lists were developed to offer new start-up organizations or FMS customers the capability to support maintenance for increments of two and five years for CH-47, and two years for UH-60, predicated on the planning factors described previously.

Initial spares are typically procured upfront for delivery with the aircraft fielding or transfer. This allows the customer unit or organization the ability to draw from its own stock until a supply system or other replenishment strategy is established. Should NSHQ nations already have CH-47D or UH-60L model aircraft within their fleets, then they should have demand-supported supplies of spares for each aircraft type.

The initial spares package cost for CH-47 is \$2.7 million. This figure represents support for one CH-47 flight company or 12 aircraft (see Table 9). Using a 25% multiplier to 15 aircraft, given the NSHQ composite fleet, the cost is \$3.38 million. However, since the initial spares are a quantity of one each per component, this multiplication factor merely represents additional costs based on wear-out, damage, or other requirements, but does not represent a wholesale cost plus up of all or one particular component.

Table 9. Recommended Push Packet Parts for Initial Sustainment (CH-47) (U.S. Army, 2012)

NSN	Noun	PN	SOS	UI	QTY	Cost	Total Cost
1615-01-315-4071	Transmission, Mechanical	145D2300-7	B17	EA	1	738,267.00	738,267.00
1615-01-317-6446	Transmission, Mechanical	145D1300-9	B17	EA	1	701,178.00	701,178.00
1615-01-464-3974	Transmission, Mechanical	145D5300-20	B17	EA	1	579,276.00	579,276.00
1615-01-287-5319	Transmission, Mechanical	145D6300-14/15	B17	EA	1	179,013.00	179,013.00
1680-01-320-1191	Shaft Assembly	145D3300-6	B17	EA	1	146,980.00	146,980.00
1615-01-395-0007	Swashplate	145R3551-18	B17	EA	1	125,178.00	125,178.00
1615-01-395-0006	Swashplate	145R3551-17	B17	EA	1	59,863.00	59,863.00
1615-01-113-0248	Shaft Assembly	145D3400-23	B17	EA	1	35,488.00	35,488.00
1615-01-112-5897	Shaft Assembly	145D3400-31	B17	EA	1	17,464.00	17,464.00
1615-01-119-3359	Shaft Assembly	145D3400-26	B17	EA	1	6,659.00	6,659.00
1615-01-112-5895	Shaft Assembly	145D3400-24	B17	EA	1	5,573.00	5,573.00
2835-01-469-3420	Engine Gas Turbine (APU)	160150-10A	B17	EA	1	109,367.00	109,367.00
						Total	2,704,306.00

The initial spares package (PP) for the UH-60 is categorized by basis of support by densities of aircraft (Fleet Manager, Utility Helicopters Project Management Office, personal conversation, June 8, 2012). As shown in Table 10, the densities are specified as 1–4 aircraft, 4–15 aircraft, and 15–30 aircraft. The PP costs are represented by repair parts costs, highlighted in blue, and are \$1.43 million, \$4.28 million, and \$10.67 million, respectively. The total spares costs (CSP) highlighted in yellow are \$4.86 million, \$8.36 million, and \$14.1 million, respectively.

Table 10. UH-60 Spares Cost Estimates

Number Aircraft	Repair Parts Cost	Non-Repairable Parts Cost	Expendable Parts Cost	Benchstock Parts Cost	Mission Equipment Replacement Parts Cost	Total Cost
1-4	\$1,430,317.74	\$2,242,362.87	\$147,887.33	\$678,805.84	\$362,813.02	\$4,862,186.80
5-14	\$4,928,238.73	\$2,242,362.87	\$147,887.33	\$678,805.84	\$362,813.02	\$8,360,107.79
15-30	\$10,672,920.10	\$2,242,362.87	\$147,887.33	\$678,805.84	\$362,813.02	\$14,104,789.16

Operational maintenance (field and sustainment levels), repair parts, and labor are cost categories that are represented by TASM-E estimates (Chief, TASM-E, personal communication, April 18, 2012). TASM-E primarily conducts periodic and phase maintenance inspections for Army aircraft in Europe, along with handling aircraft transportation operations in support of deploying aircraft to Operation Enduring Freedom and redeployment. Additionally, TASM-E supports transportation for the retrograde of aircraft back to CONUS or to repair facilities (CONUS or Europe).

The repair parts list and direct labor (burdened) for each periodic or phase maintenance inspection are the calculated costs associated with each aircraft. TASM-E reports this in its aircraft repair cost (ARC) reports. This research report calculated the repair parts and direct labor (burdened) costs for each aircraft from the ARC reports for a period of two years (FY2010–FY2011). The costs represented and then estimated for each aircraft type are mean averages of the maintenance conducted by TASM-E at their facilities in Germany or elsewhere in Europe, in support of 12th Combat Aviation Brigade and other post-deployment aircraft.

The labor costs associated with TASM-E support for continuous operations at the field and sustainment levels of maintenance were established from estimates provided by TASM-E. This labor estimate represents labor force size to support varying aircraft densities. The per hour estimate provided by TASM-E was \$75 per hour and is burdened, fully inclusive of manpower requirements, overhead, and other administrative fee schedules.

There are additional labor costs aside from hourly rates, and manning numbers represent the requirement for two personnel. These personnel are a Quality Assurance Representative (QAR) and a Contracting Officer's Representative (COR). This requirement accounts for two man-years (2 MY) or \$240,000. The QAR and COR represent fixed labor costs, whereas the manning levels to support the NSHQ aircraft project are variable based on demand.

Theater Aviation Sustainment Manager–Europe (TASM-E) is a GO-GO contract valued at \$3.5 billion over five years. To acquire the services of TASM-E, NSHQ through USSOCOM or USAREUR would issue funding to begin the project task order via a MIPR on a DD448. Upon receipt of funds and acceptance via MIPR, TASM-E would then begin to organize and develop the support package. The inclusion of NSHQ aircraft would be done via a project task order to the TASM-E contract. The cost estimates of establishing the task order are based on

hourly labor that can be funded incrementally and adjusted with the requirement to support variable aircraft densities, dedicated QAR and COR, and AGSE to support the NSHQ project. Materiel (repair parts) is also variable.

The costs associated with TASM–E Support follow:

- Labor

Labor rate (all inclusive) is \$75. For example, if 20 personnel are needed to execute a project,

$$20 \times 2080 \times \$75 = \$3,132,000 \quad (1)$$

To support 30 aircraft would require 30–40 personnel (see Equations 2 and 3), plus two maintenance test pilots per aircraft Military Density System (MDS). Maintenance test pilots would be the shared resource of TASM–E or can also be provided by unit.

$$30 \times 2080 \times \$75 = \$4,680,000 \quad (2)$$

$$40 \times 2080 \times \$75 = \$6,240,000 \quad (3)$$

Additional labor required: Two quality assurance personnel are assigned, the Contracting Officer’s Representative (COR) and Quality Assurance Representative (QAR). The cost for these personnel is \$240,000. These two personnel are assigned to the NSHQ aircraft fleet project. These individuals must be committed only to the project and not a shared TASM–E resource like maintenance test pilots.

- Materiel

Parts/equipment/consumables/other materiel costs are borne by the customer. The sustainment and spares packages provided by aircraft PM should be used to compute yearly expenditures per airframe.

However, TASM–E historical data for reset (repair at near overhaul level) place the average materiel cost range for UH-60 MDS at \$650,000–\$800,000 per aircraft. For CH-47D reset, the average materiel cost range is \$700,000–\$2,100,000.

- AGSE

Customers should be able to provide aviation ground support equipment to support maintenance of their aircraft. Relying on TASM–E equipment could result in unnecessary

delays to the process. See Appendix C (Table 14) AGSE chart for total AGSE package costs. A specific package can and should be tailored to the NSHQ aircraft fleet project beyond initial estimates/requirements, especially if conducting split-based operations or deployment. Maintenance of AGSE equipment is included in the TASM–E project.

Cost Estimate Projections

Cost estimates were performed to plan for a specific time horizon. The specific time horizon chosen was FY2014 through FY2019. This time horizon covers the NSHQ initial operational capability (IOC) based on its level of ambition and extends out five years. FY2014 also represents the timeframe during which USSOCOM would become the Executive Agent for the NSHQ framework from the U.S. Army, in particular U.S. Army Europe (USAREUR). Additionally, FY2014 through FY2019 represents the years of divestiture for UH-60A/L and CH-47D in which each aircraft PM office will be retiring aircraft according to their current cascade plans. FY2013 was used as the base year and represents many of the initial costs to set up the NSHQ project, such as AGSE, TASM–E support, and perhaps initial aircraft quantities (one or more, single-digit).

Costs of Concurrent Spare Parts (CSP) were programmed at the respective two- and five-year increments over this period by aircraft type. While replenishment of stock levels would be a continuous process and such stock levels could be adjusted by demand or directive, the cost estimate represents replenishment in total at each increment. These costs may be higher than what could be expected in real time; however, the higher cost would represent worst case scenarios and help deal with other uncertainties. Repair parts and labor costs by aircraft type and densities represent periodic and phase maintenance inspection activity throughout the year at maximum densities (as stated). An estimated five periodic and phase maintenance inspection activities are more likely (per aircraft type) based on averages presented in the TASM–E ARC reports.

The repair and labor costs for these five iterations are also included in cost estimate charts and depicted in Table 11 and Table 12. The additional hourly labor costs and costs of QAR and COR are also included as TASM–E NSHQ project costs. These projected costs are represented by the 20- and 40-personnel increments in the charts (see Table 12).

Table 11. O&M Costs for 5 Periodic/Phase Maintenance Cycles by Aircraft Type (MDS)

Cost Activity	Amount	BY2013	FY2014	FY2015	FY2016	FY2017	FY2018	FY2019	TOTAL
TOTAL O & M for 5 periodic/phase maintenance cycles per year (C)	\$7,978,997.75	\$7,978,997.75	\$8,242,304.68	\$8,514,300.73	\$8,795,272.65	\$9,085,516.65	\$9,385,338.70	\$9,695,054.88	\$53,717,788.29
TOTAL O & M for 5 periodic/phase maintenance cycles per year (U)	\$5,160,121.30	\$5,160,121.30	\$5,330,405.30	\$5,506,308.68	\$5,688,016.86	\$5,875,721.42	\$6,069,620.23	\$6,269,917.70	\$34,739,990.19
		\$13,139,119.05	\$13,572,709.98	\$14,020,609.41	\$14,483,289.52	\$14,961,238.07	\$15,454,958.93	\$15,964,972.57	\$88,457,778.48

Table 12. TASM-E Labor Costs to Support NSHQ Project

TASM-E Direct Labor Costs (incrementally funded)									
Yearly Labor costs to support 1-15 Aircraft (20 personnel)	\$3,120,000.00								
Yearly Labor costs to support 16-30 Aircraft (40 personnel)	\$6,240,000.00	\$6,240,000.00							
Yearly Labor costs (COR and QAR)	\$240,000.00	\$240,000.00							
Operating TOTAL (based on 1-15 A/C per MDS)	\$3,360,000.00	\$3,360,000.00	\$3,470,880.00	\$3,585,419.04	\$3,703,737.87	\$3,825,961.22	\$3,952,217.94	\$4,082,641.13	\$22,620,857.19
Operating TOTAL (based on 16-30 A/C per MDS)	\$6,480,000.00	\$6,480,000.00	\$6,693,840.00	\$6,914,736.72	\$7,142,923.03	\$7,378,639.49	\$7,622,134.60	\$7,873,665.04	\$43,625,938.88

Inflation is accounted for in the cost estimate charts (see Table 13). The historic inflation rate since 1913 is 3.24% (“Historical Inflation Rates,” n.d.). The costs were further treated for inflation to the rate of 3.3% to account for additional uncertainty. Additional treatment offers budgetary slack, especially with the prices of government-furnished materiel (repair parts and aircraft components) accounting for procurement, warehousing, transportation, and other administrative costs. Cost categories that are initial or upfront costs, such as AGSE, were not treated for inflation.

Table 13. Life-Cycle Costs by Cost Activity (Less Fuel and Flying Hours)

Cost Activity	Amount
Cost Activity Category TOTALS	
AGSE TOTAL (Upfront-FY13)	\$4,754,528.96
CSP & PP TOTAL (5 YR per CH-47; 2 YR per UH-60; Upfront-FY13)	\$7,566,492.80
CSP & PP TOTAL (based on 1 A/C per MDS; FY14-19)	\$61,351,629.27
CSP & PP TOTAL (based on 1 A/C per MDS; through FY19)	\$68,918,122.07
CSP & PP TOTAL (based on 15 A/C per MDS; Upfront-FY13)	\$48,431,258.65
CSP & PP TOTAL (based on 15 A/C per MDS; FY14-19)	\$88,626,915.70
CSP & PP TOTAL (based on 15 A/C per MDS; through FY19)	\$137,058,174.34
O & M TOTAL (based on 1 A/C per MDS; Upfront-FY13)	\$5,987,823.81
O & M TOTAL (based on 1 A/C per MDS; FY14-19)	\$40,312,412.89
O & M TOTAL (based on 1 A/C per MDS; through FY19)	\$46,300,236.70
O & M TOTAL (based on 15 A/C per MDS; Upfront-FY13)	\$45,897,357.15
O & M TOTAL (based on 15 A/C per MDS; FY14-19)	\$308,999,274.32
O & M TOTAL (based on 15 A/C per MDS; through FY19)	\$354,896,631.47
TOTAL per AIRCRAFT (Upfront-FY13) + AGSE	\$18,308,845.57
TOTAL per AIRCRAFT (FY14-FY19)	\$101,664,042.16
TOTAL per AIRCRAFT (through FY19)	\$119,972,887.73
TOTAL per 15 AIRCRAFT (Upfront-FY13) + AGSE	\$99,083,144.76
TOTAL per 15 AIRCRAFT (FY14-FY19)	\$397,626,190.01
TOTAL per 15 AIRCRAFT (through FY19)	\$496,709,334.77
TOTAL O & M for 5 periodic/phase maintenance cycles per year (C)	\$7,978,997.75
TOTAL O & M for 5 periodic/phase maintenance cycles per year (U)	\$5,160,121.30
Application of historical rate of inflation since 1913 of 3.24%, further treated to 3.3% (source: inflationdata.com)	1.033

THIS PAGE INTENTIONALLY LEFT BLANK

IX. RECOMMENDATIONS

Findings

With 28 member nations, NATO is not one unit with one personality. Each member nation has its own economic and military challenges. In order to stand up a NATO SOF Air Wing quickly at a sustainable cost, the U.S. could take the lead and provide rotary-wing aircraft to begin the training process of member nations. Using excess defense articles, CH-47, and UH-60, the U.S. can avoid the costs associated with putting aircraft in the boneyard and instead use existing aircraft at a relatively low cost for the establishment of a SOF air wing. This strategy will shift cost and allow an immediate capability without relying on 28 nations to come to an agreement on which aircraft to fly and who will pay for it. Although this strategy is not long term, it is effective and efficient for the short term.

In order for the U.S. and NSHQ to push the Smart Defense approach, the U.S. could provide a short-term plan for rapid implementation. The retiring CH-47D and UH-60L are proven capabilities that are still being used in Afghanistan today. Using these aircraft will provide a stop-gap solution with low cost to the U.S. government. By providing a short-term solution, the U.S. will shorten the distance between the idea of an air wing for NATO and the reality of the capability. This solution buys time for member nations to begin training and working through the cultural, administrative, geographical, and economic distances between them. In the long term, this will alleviate the U.S.'s cost burden and allow NATO to begin playing a larger role in future conflicts. This strategic model can also be adapted to similar partnerships developing in the Pacific in order for the U.S. to continue to implement a Smart Defense strategy throughout the globe.

Conclusion

USSOCOM remains committed to the viability of NATO SOF and its necessary enablers as a means to ensure that this tremendous capability is not challenged in this time of austere defense budgets. As the framework nation for NSHQ, the U.S. will continue to provide materiel and manpower to the organization in an effort to ensure

interoperability and enhanced capability to the NATO Alliance as it “pivots” to Asia and continues to “hold” in the Middle East. We have demonstrated that an initial rotary-wing capability can be realized to provide training and standardization by providing legacy EDA aircraft to NSHQ as a near-term solution. Regardless of the airframe chosen, program management will be a challenge that should be addressed before any acquisition is undertaken. We recommend that the initial aerial platform materiel solution come from the transfer of EDA aircraft and that its programmatic life cycle be managed by USSOCOM SORDAC PEO–Rotary Wing. If NATO SOF Aviation is to sustain itself as a fully–mission-capable organization for the future, it will have to keep the Smart Defense principle in the forefront and ensure that Smart Defense is understood, accepted, and executed by all NATO SOF nations.

APPENDIX A: DIVESTITURE

For the purpose of this report, *excess* and *extra* equipment or systems may be used interchangeably. The usage of these two words refers to the aircraft systems above the Acquisition Objective numbers authorized in accordance with acquisition documentation and other regulatory guidance. Operationally, *excess* aircraft implies an excess defense article that is typically non-flyable and in a preserved/storage status; *extra* aircraft is commonly used to refer to flyable or otherwise serviceable condition aircraft.

The U.S. Department of Defense acquisition life cycle includes initial concept, development, production, deployment, operations, and sustainment. The total life cycle concludes with disposal that represents the culmination of the operations and sustainment phase. At the end of its useful life, a system shall be demilitarized and disposed of in accordance with all legal and regulatory requirements and policy relating to safety (including explosives safety), security, and the environment (Under Secretary of Defense for Acquisition, Technology, and Logistics [USD(AT&L)], 2008).

Disposal may be in the form of demilitarization and conversion to actual scrap or removal from government property books via sale or transfer. Sale or transfer may occur through Foreign Military Sales, Defense Reutilization and Marketing, Other Government Agencies, or donation. The various options for disposal are covered by the *Defense Materiel Disposition Manual* (DoD, 1997). Divestiture is the process of retiring older, less capable (and attrite) aircraft tail numbers from the government inventory in favor of modernized configurations. This process includes a screening process affording Service Component and Other Government Agencies (OGA) the opportunity to reutilize aircraft prior to disposal (U.S. Army, Program Executive Office Aviation, 2012).

Definitions

The definitions for the following terms were taken from the *Defense Materiel Disposition Manual* (DoD, 1997), and they guided our discussion of divestiture of U.S. government property:

Demilitarization is the act of destroying the military offensive or defensive advantages inherent in certain types of equipment or materiel. The term includes mutilation, dumping at sea, scrapping, melting, burning, or alteration designed to prevent the further use of this equipment and materiel for its original intended military or lethal purpose and applies equally to materiel in unserviceable or serviceable condition that has been screened through an Inventory Control Point and declared excess or foreign excess. (p. xviii)

Donable Property is property under the control of a Military Service/Defense Agency (including surplus personal property in working capital funds established under 10 U. S.C. 2208 or in similar management-type finds) authorized for donation by statute. A Service Educational Activity; a State, political subdivision, municipality, or tax-supported institution acting on behalf of a public airport; a public agency using surplus personal property in carrying out or promoting for the residents of a given political area one or more public purposes such as conservation, economic development, education, parks and recreation, public health, and public safety; an eligible nonprofit tax-exempt educational or public health institution or organization; a public body; a charitable institution; or any State or local government agency, and any nonprofit organization or institution. (p. xix)

Excess is defined based upon point in time as follows: (1) Military Service/Defense Agency Excess. That quantity of an item of Military Service/Defense Agency owned property that is not required for its needs and the discharge of its responsibilities as determined by the head of the Service/Agency (this property shall be screened by a DoD activity for DoD reutilization). (2) DoD Excess. That quantity of an item that has completed screening within DoD and is not required for the needs and the discharge of the responsibilities of any DoD activity. (This screening may have been accomplished by DRMS, Special Defense Property Disposal Accounts, Defense Information Systems Agency, and other designated DoD agencies. This property is subject to Federal civil agency screening by the GSA.) (p. xxi)

Excess is further defined based upon location as follows: (1) Domestic Excess. Both the terms Military Service/Defense Agency Excess and DoD Excess relate to domestic excess; that is, property located in the United States, American Samoa, Guam, Puerto Rico, Trust Territory of the Pacific Islands, and the Virgin Islands. When all reutilization screening is completed on domestic excess property, it becomes surplus and eligible for donation and sale. (2) Foreign Excess Property. Any U.S.-owned excess property located outside the United States and territories above. (p. xxi)

Foreign Military Sales (FMS) is a process through which eligible foreign governments and international organizations may purchase defense articles and services from the U.S. Government. A government-to-government agreement, documented in accordance with *Security Assistance Management Manual*, DoD 5105.38-M. (p. xxii)

Inventory Control Point, An organizational unit or activity within a DoD supply system which is assigned the primary responsibility for the materiel management of a group of items either for a particular Service or for the DoD as a whole. Materiel inventory management includes cataloging direction, requirements computation, procurement direction, distribution management, disposal direction, and, generally, rebuild direction. (p. xxv)

Marketing is the function of directing the flow of surplus and foreign excess property to the buyer, encompassing all related aspects of merchandising, market research, sale promotion, advertising, publicity, and selling. (p. xxvi)

Military Assistance Program (MAP) Property is U.S. security assistance property provided under the Foreign Assistance Act, generally on a non-reimbursable basis. (p. xxvii)

Reutilization is the determination of available excess, surplus, or foreign excess personal property, to meet known or anticipated requirements. (p. xxi)

Jurisdiction/Regulatory

The Defense Security Cooperation Agency (DSCA) is the central agency that synchronizes global security cooperation programs, funding, and efforts across the Office of the Secretary of Defense, Joint Staff, State Department, COCOMS, the Services, and U.S. industry. The DSCA is responsible for the effective policy, processes, training, and financial management necessary to execute security cooperation within the DoD (DSCA, n.d.). Each Service component operates its own organization that coordinates security cooperation programs. For the Department of the Army, that organization is the U.S. Army Security Assistance Command, a subordinate command under the U.S. Army Materiel Command. For the Department of the Navy, the Navy International Programs Office manages the Navy's security assistance programs. Regardless of Service, each system's program management office conducts all programmatic activities and retains

system life-cycle management responsibility, responding to FMS cases as directed by the security assistance organization of their Service component.

Excess defense articles are equipment or systems (articles) owned by the U.S. government that are neither procured in anticipation of military assistance or sales requirements, nor procured pursuant to a military assistance or sales order. EDA are items (except construction equipment) that are in excess of the Approved Force Acquisition Objective and Approved Force Retention Stock of all DoD components at the time such articles are dropped from inventory by the supplying agency for delivery to countries or international organizations. EDA are further defined as DoD- and United States Coast Guard (USCG)-owned defense articles no longer needed and declared excess by the U.S. Armed Forces. This excess equipment is offered at reduced or no cost to eligible foreign recipients on an “as is, where is” basis. The EDA program works best in assisting friends and allies to augment current inventories of like items with a support structure already in place (DSCA, 2012).

All countries that are eligible for FMS are eligible for EDA. EDA may also be provided to countries via grant process vice sale. Grants of EDA must be justified to the Congress via the annual notification letters to Congress with concurrence of the Department of State (DoS). This justification must be done for the fiscal year when the transfer of EDA takes place. Priority delivery of grant EDA is given to NATO countries and to major non-NATO allies on the southern and southeastern flank of NATO, and to the Philippines to the maximum extent feasible over the delivery of such excess defense articles to other countries (FAA, 1961, § 516(c)(2)). Countries currently eligible for priority delivery are Egypt, Greece, Israel, Jordan, Portugal, and Turkey. Next priority is to countries eligible for assistance authorized by the NATO Enlargement Facilitation Act of 1996 (§ 609). These countries include Poland, Hungary, the Czech Republic, and Slovenia (NATO Enlargement Facilitation Act, 1996, § 606) (DSCA, n.d.-e).

The U.S. Army divests its excess aircraft in accordance with the Program Executive Office Aviation’s *Army Aircraft Divestiture Operating Procedure, Version 1* (U.S. Army, Program Executive Office Aviation, 2012). The nine basic steps or options for this process are declaring excess, issue to other DoD activities, offer parts for

reclamation, issue to the Law Enforcement Support Office, issue to the Security Assistance Management Directorate, issue to a Federal Civil Agency, donate through the Army Donations Program Office, or send to DLA Disposition Services. This research report focuses on the declaration of excess, issue to other DoD activities, and issue to Security Assistance Management Directorate. Emphasis is placed on the former two steps.

Screening of aircraft for declaration of excess, issue to other DoD activities, or other issuance of whole aircraft are further categorized as follows (see Figure 13):

- Category A—Aircraft that are authorized for sale and exchange for commercial use that do not require DEMIL.
- Category B—Aircraft that are used for ground instructional and static display as they have not been maintained to airworthiness standards.
- Category C—Aircraft that are uniquely designed/configured for military combat or are non-flyable.

Services report excess to the General Services Administration (GSA), who may request transfer of an aircraft to a Federal Civil Agency for continued flight use prior to reclamation.

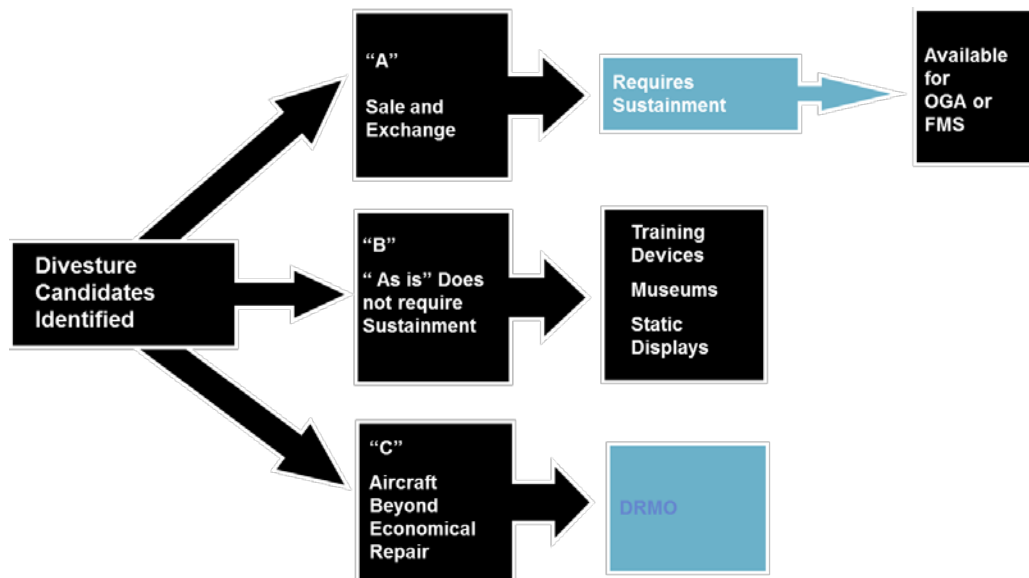

Figure 13. Army Aircraft Divestiture Screening Process (Utility Helicopters Project Management Office, 2012)

Retiring Army aircraft are transferred from the PM office to the gaining activity or agency (DLA, other DoD, OGA, etc.) via Issue Release Receipt Document, DD form 1348-1, in accordance with applicable procedures within the DoD enterprise. The Army regulation and proceedings are prescribed in AR 725-50, *Requisitioning, Receipt, and Issue System* (U.S. Army, 1995). An aircraft transfer to NSHQ via the U.S. framework organization would be appropriate since the Army PM office for the particular aircraft would be able to sign over the property to another DoD activity. The transportation of the aircraft to NSHQ facilities or those of the initial gaining activity would be the responsibility of the receiving party.

APPENDIX B: TASM-E INFORMATION AND CAPABILITIES

The following information brief describes the mission and capabilities of Theater Aviation Sustainment Manager–Europe, a U.S. Army Aviation and Missile Command organization. TASM-E specifically operates under the Aviation Field Maintenance Directorate. Both USAAMCOM and AFMD are headquartered in Huntsville, Alabama, at Redstone Arsenal. TASM-E is headquartered in Mannheim, Germany (Chief, TASM-E, personal communication, April 18, 2012).

AMCOM TASM-Europe

Site Briefing



15 April 2012

UNCLASSIFIED / FOR OFFICIAL
USE ONLY



TASM-Europe Goals

Posture TASM-Europe assets to best satisfy the future aviation maintenance needs of:

- Department of the Army
- EUCOM, AFRICOM, CENTCOM
- AMCOM
- Customer – 12th Combat Aviation Brigade

Right-size AMCOM/TASM-Europe assets based on ARFORGEN and unit requirements in a post-war environment

Maintain a 'warm base', capable of providing global support to the war-fighter during any future conflicts

UNCLASSIFIED / FOR OFFICIAL
USE ONLY

2



Agile Mission Responsiveness

Establish a customer-focused Theater Aviation Maintenance capability

- RESET
- Customer Passback
- Modifications
- FMS

Maintain major item maintenance capabilities in Theater (limited crash and battle damage repairs)

Provide a proportional technical presence throughout the region by utilizing TASM-Europe assets

Have a capable and trained MWO/mobile support capability for War and Contingency Operations utilizing CFT contractor work force

UNCLASSIFIED / FOR OFFICIAL USE ONLY

3



TASM-E Sites Aligned with CAB and Location

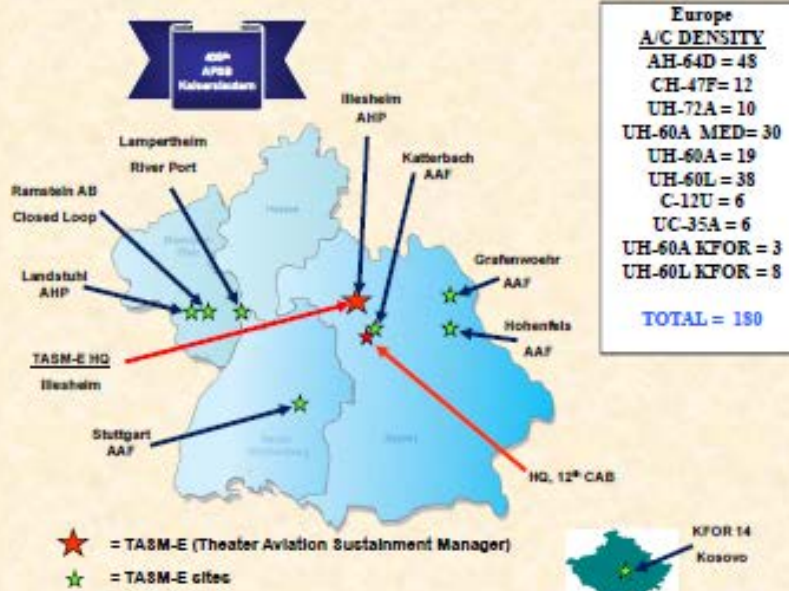

UNCLASSIFIED / FOR OFFICIAL USE ONLY

4



Aviation Specialized Repair Capability

1. Engine Test Cell – FEDS provide the capability for “off wing” testing and evaluation that can limit downtime for aircraft awaiting engines and assist Sustainment organizations (AVIM) with repair and return capability
2. Aircraft Blade Repair – Providing limited DEPOT repair, static blade balancing assisting the Sustainment repair operations on an as needed basis
3. Component Repair – Provides a robust avionics, electronic and aircraft component testing and repair at Sustainment level as needed to enhance mission readiness
4. Machine Shop – Special Tool Manufacturing, welding and full line of NDI capabilities needed in support of Sustainment operations
5. Reset/Phase Capability – P4T3 for 14 aircraft in work simultaneously capability to support LBE and MOB efforts as requested
6. Aircraft Painting – Includes chemical stripping

UNCLASSIFIED / FOR OFFICIAL USE ONLY

5



Aviation Specialized Repair Capability

TASM Europe	
	Storck/Coleman AAF Illesheim/Mannheim
Blade Repair	X
Blade Dryer	
FEDS Capability	X
Powertrain	X
Machine Shop	X
Airframe Repair	X
Hydraulic Shop	X
Electrical Shop	X
Paint Capability	X
SAMS	X
ULLS-AE	X

UNCLASSIFIED / FOR OFFICIAL USE ONLY

6

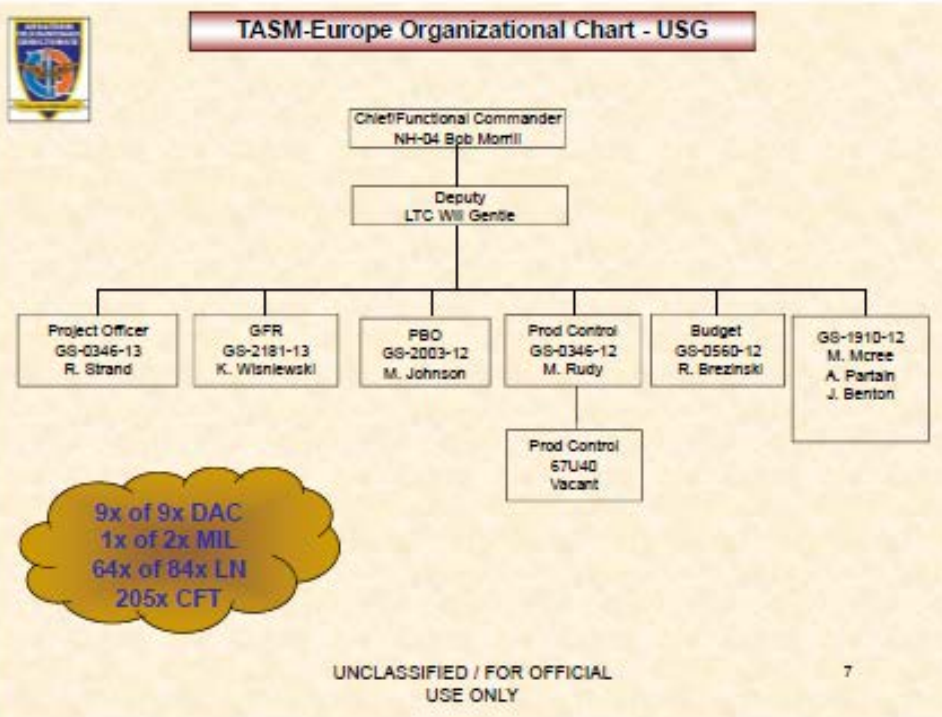

Statistical Data

CONTRACTOR WORKFORCE (Total 205)

	TASM-E
MWO	78
RESET	0
12 th CAB Direct Support	106
KFOR 14	21
Total	205

UNCLASSIFIED / FOR OFFICIAL USE ONLY 8



Statistical Data

FULL TASM-E PERFORMANCE

Reset ACFT Completed Since Program Inception (2004)

• AH64A&D	66
• CH47D	39
• UH60A	80
• UH60L	<u>156</u>
	341

UNCLASSIFIED / FOR OFFICIAL
USE ONLY

9



Statistical Data

FULL TASM-E PERFORMANCE

2011 RESET

TASM-E	TAT	M/H	Parts
UH-60A	83 (106)	7,008	\$755,049.71
UH-60L	80 (79)	4,404	\$689,009.10
AH-64D	82 (89)	4,748	\$744,482.70

UNCLASSIFIED / FOR OFFICIAL
USE ONLY

10



Statistical Data

FULL TASM-E PERFORMANCE

MWO Totals For FY 2011

• AH64	18
• CH47	73
• OH58	63
• UH60	<u>159</u>
	313 as of 30 Sep

UNCLASSIFIED / FOR OFFICIAL
USE ONLY

11



Statistical Data

FULL TASM-E PERFORMANCE

ACE/A3T Totals For FY 2011

• AH64D	35
• CH47D & F	54
• OH58D	68
• UH60A & L	<u>140</u>
	297 as of 30 Sep

UNCLASSIFIED / FOR OFFICIAL
USE ONLY

12



Coleman AAF TASM-E, Reset Site

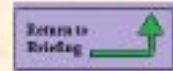

Facilities:

- 2 Hangars Accommodating 14 Rotary wing aircraft
- Aircraft Paint Booth
- Aircraft Engine Test Cell
- Backshop Areas

Capabilities:

- Field (AVUM), Sustainment (AVIM), and Limited Depot
- AMCOM Managed Depot Level Modification Program
- AMCOM Managed RESET Operations
- Aircraft Painting

Manpower:

- DOD Civilians – 9
- Military – 2
- Local Nationals – 64
- Contractors – 205

UNCLASSIFIED / FOR OFFICIAL
USE ONLY

15

APPENDIX C: AGSE AND PGSE EQUIPMENT DESCRIPTION

Aviation Ground Support Equipment and Peculiar Ground Support Equipment below in Table 14 represent requirements that must be on hand in order for TASM-E to support NSHQ mission and training requirements. Peculiar Ground Support Equipment is generally support equipment specific to one particular aircraft series. For example, the Kit Air Transportability only applies to the UH-60 series aircraft and is not applicable to the CH-47 series aircraft.

Table 14. Aviation Ground Support Equipment and Peculiar Ground Support Equipment

TASM-E NSHQ Project Task Order
AGSE / PGSE Requirements

ITEM	REFERENCE	LIN	ERC	Nomenclature	QTY REQ	Unit Cost*	Total Cost
1	TASM Slide 3	C36151	A	CRANE WHEEL MTD: HYDRAULIC LIGHT 7-1/2 TON W/CAB (*)	2	\$58,481.00	\$116,962.00
2	TASM Slide 2	E03826	A	ELECTRONIC TEST SET: TS-4348/UV	1	\$677.32	\$677.32
3	AGSE Slide 14	G90261	A	GENERIC: AIRCRAFT NITROGEN GENERATOR (GANG)	1	\$139,182.12	\$139,182.12
4	TASM Slide 4	K27251	A	KIT AIR TRANSPORTABILITY: UH-60A [PGSE Item]	15	\$0.00	\$0.00
5	AGSE Slide 20	L09135	A	JACK ACFT LANDING GEAR: 5 T 5-1/2 IN MIN H 17-1/2 IN MAX EXT H	4	\$1,302.29	\$5,209.16
6	AGSE Slide 21	L09340	A	JACK HYDRAULIC HAND: 10 TON SELF-CONTAINED	4	\$1,857.13	\$7,428.52
7	AGSE Slide 23	L10532	A	JACK HYDRAULIC TRIPOD: 3 TON CAPACITY	4	\$966.33	\$3,865.32
8	AGSE Slide 24	L10559	A	JACK HYDRAULIC TRIPOD: 5 TON CAPACITY	2	\$4,237.37	\$8,474.74
9	AGSE Slide 10, 11	M02504	A	MAINTENANCE PLATFORM: HYDRAULIC ADJUSTABLE TYPE 3 TO 7 FT H (B1 & B4)	3	\$16,709.13	\$50,127.39
10	AGSE Slide 12	P44627	A	POWER UNIT AUXILIARY: AVIATION MULTI-OUTPUT GTED (AGPU)	3	\$1,204,047.41	\$3,612,142.23
11	AGSE Slide 13	S30224	A	SHOP EQUIPMENT CONTACT MAINTENANCE (SECM): AVIATION (SHELTER ONLY-Nonmodernized)	2	\$10,500.00	\$21,000.00
12	AGSE Slide 8	T03597	A	TESTER: PITOT AND STATIC SYSTEMS-4463/P	2	\$57,405.51	\$114,811.02
13	AGSE Slide 16	T53635	A	TEST SET: AVIATION VIBRATION ANALYZER (AVA)	3	\$33,097.83	\$99,293.49
14	AGSE Slide 18	T65997	A	TOOL SET: AVIATION FOOT LOCKER -MAN PORTABLE SPT PM ACFT	12	\$8,412.58	\$100,950.96
15	AGSE Slide 15	U87773	A	UNIT MAINTENANCE AERIAL RECOVERY KIT: (UMARK)	2	\$153,332.76	\$306,665.52
16	AGSE Slide 9	V77715	A	TEST SET ACFT FUEL QUANTITY GAGE AND INDICATOR: PORTABLE, SUBLIN FG2507	2	\$12,700.72	\$25,401.44
17	AGSE Slide 25	W89528	A	TOWBAR MOTOR VEHICLE: WHEELED VEHICLE, SUBLIN W89391	5	\$1,057.79	\$5,288.95
18	AGSE Slide 4	W88803	A	TRACTOR WHEELED AIRCRAFT TOWING: GAS OP, SUBLIN S21580 SATS (*)	2	\$65,872.39	\$131,744.78
19	TASM Slide 1	W93995	A	TRAILER ACFT MAINT AIRMOBILE: 4 WHEELED 30/48 IN TRF RAIL SYSTEM	2	\$2,652.00	\$5,304.00

Notes:

(*) indicates COTS or GOTS equivalent variant and plus up quantity of 1 above requirement

[PGSE Item] indicates flyaway kit that should become available with aircraft

(SHELTER ONLY-Nonmodernized) indicates SECM as shelter only without prime mover integrated system

\$4,754,528.96

LIN: C36151, CRANE WHEEL MTD: HYDRAULIC LIGHT 7-1/2 TON W/CAB



3

Figure 14. Crane Wheel MTD: Hydraulic Light 7-1/2 Ton With Cab (Chief, TASM-E, personal communication, April 18, 2012)

LIN: E03826, TEST SET TS-4348/UV
NSN: 6625-01-323-9584 Cost: \$677.32
TM 11-5855-299-12 & P

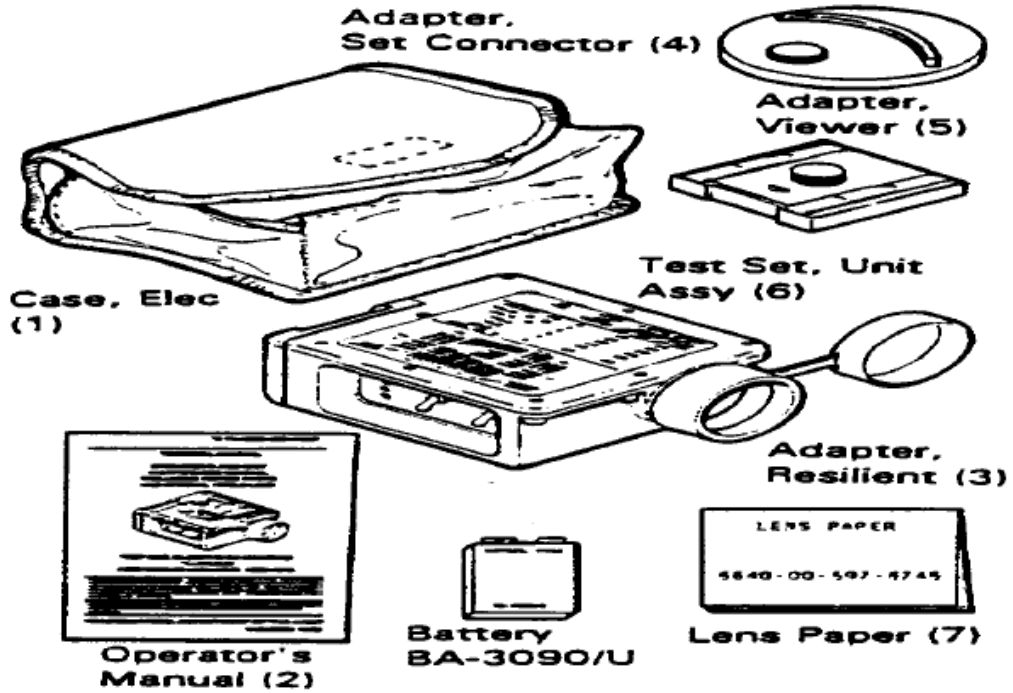

Figure 15. Electronic Test Set: TS-4348/UV (Chief, TASM-E, personal communication, April 18, 2012)



Generic Aircraft Nitrogen Generator (GANG)



DESCRIPTION:
 The GANG produces 95.5% pure nitrogen to service/adjust aircraft accumulators, main rotor blades, landing gear struts and tires. The system refills nitrogen bottles used at all levels of aviation maintenance

FY:	FY11	FY12	FY13	FY14	FY15
Unit COST:	\$120,097.63	\$122,358.02	\$124,425.01	\$126,540.23	\$128,691.42
Spare Parts	\$11,212.48	\$11,423.51	\$11,616.49	\$11,813.97	\$12,014.81
Consumables	\$3,031.39	\$3,088.44	\$3,140.62	\$3,194.01	\$3,248.31

BASIS of ISSUE (BOI):

ASC/AMC	BOI
ASC	1
AMC	1
AVCRAD	1

LIN: G90261
 NSN: 3655-01-568-2711

UNCLASSIFIED

14

Figure 16. Generic: Aircraft Nitrogen Generator (GANG)
 (Aviation Ground Support Equipment Product Management Office, AGSE
Product List, 2012)

LIN: K27251, KIT AIR TRANSPORTABILITY: UH-60A

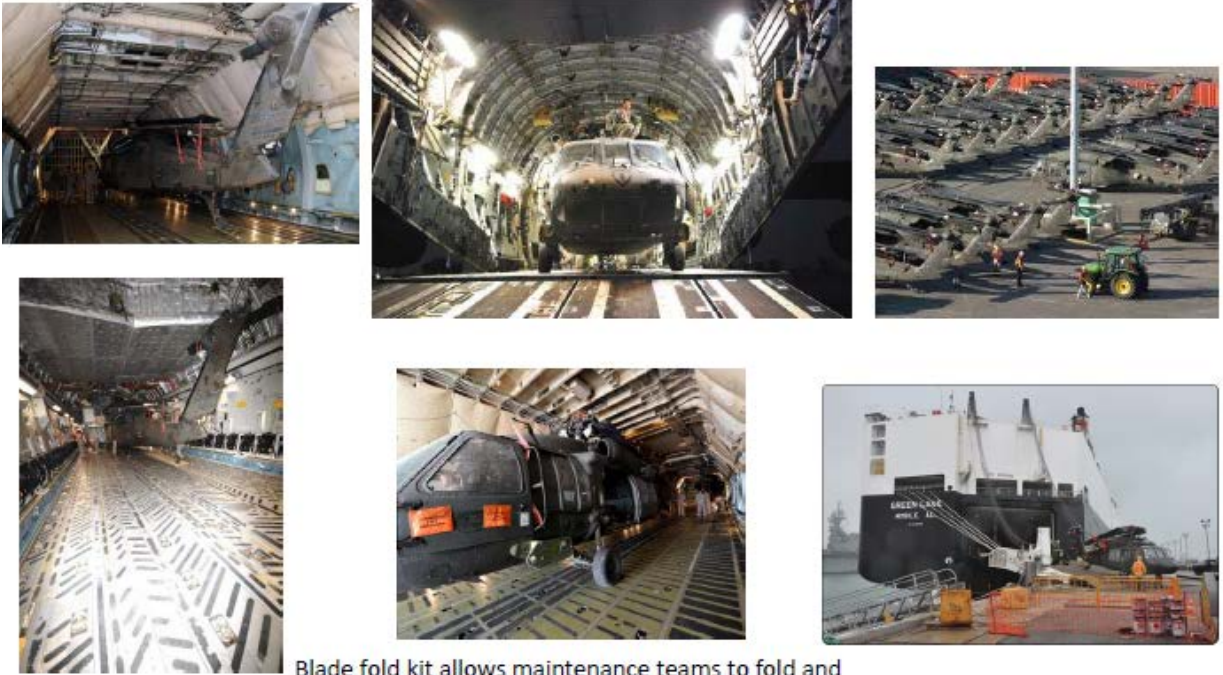

Blade fold kit allows maintenance teams to fold and drop the blades on the Blackhawk helicopter for air-transportability or sea-lift .

4

Figure 17. Kit Air Transportability: UH-60A [PGSE Item] (Chief, TASM-E, personal communication, April 18, 2012)



Jack Hydraulic Hand: 5 Ton



	<p>DESCRIPTION: Aviation Maintenance Jacks provide a stable working lifting device for Army rotorcraft maintenance activities and enhance the occupational safety environment for maintainers.</p> <table border="1" style="width: 100%; border-collapse: collapse; margin-top: 10px;"> <thead> <tr> <th style="text-align: left;">FY:</th> <th>FY11</th> <th>FY12</th> <th>FY13</th> <th>FY14</th> <th>FY15</th> </tr> </thead> <tbody> <tr> <td style="text-align: left;">COST:</td> <td>\$1,257.00</td> <td>\$1,280.66</td> <td>\$1,302.29</td> <td>\$1,324.43</td> <td>\$1,346.95</td> </tr> </tbody> </table>	FY:	FY11	FY12	FY13	FY14	FY15	COST:	\$1,257.00	\$1,280.66	\$1,302.29	\$1,324.43	\$1,346.95
FY:	FY11	FY12	FY13	FY14	FY15								
COST:	\$1,257.00	\$1,280.66	\$1,302.29	\$1,324.43	\$1,346.95								
<p>BASIS OF ISSUE (BOI):</p> <table border="1" style="width: 100%; border-collapse: collapse; margin-bottom: 10px;"> <tr> <td style="width: 30%;">AMC</td> <td>Four (4) per</td> </tr> <tr> <td>ASC</td> <td>Four (4) per</td> </tr> </table> <table border="1" style="width: 100%; border-collapse: collapse;"> <tr> <td style="width: 50%;">LIN: L09135</td> <td>NSN: 1730-00-540-2343</td> </tr> </table>	AMC	Four (4) per	ASC	Four (4) per	LIN: L09135	NSN: 1730-00-540-2343							
AMC	Four (4) per												
ASC	Four (4) per												
LIN: L09135	NSN: 1730-00-540-2343												

UNCLASSIFIED

Figure 18. Jack ACFT Landing Gear: 5 T 5-1/2 IN MIN H 17-1/2 IN MAX EXT H
(Aviation Ground Support Equipment Product Management Office, AGSE
Product List, 2012)



Jack Hydraulic Hand: 10 Ton

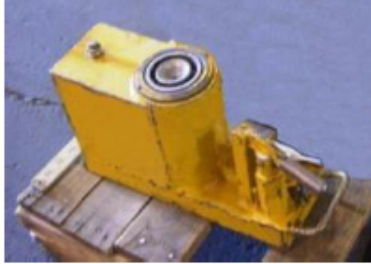

DESCRIPTION:

Aviation Maintenance Jacks provide a stable working lifting device for Army rotorcraft maintenance activities and enhance the occupational safety environment for maintainers.

DLA Managed Item

FY:	FY11	FY12	FY13	FY14	FY15
COST:	\$1,789.19	\$1,822.10	\$1,857.13	\$1,892.09	\$1,927.70

BASIS OF ISSUE (BOI):

AMC	Two (2) per
ASC	Two (2) per

LIN: L09340
NSN: 1730-00-203-4697

UNCLASSIFIED

21

Figure 19. Jack Hydraulic Hand: 10 Ton Self-Contained (Aviation Ground Support Equipment Product Management Office, *AGSE Product List*, 2012)



Jack Hydraulic Hand: 3 Ton



	<p>DESCRIPTION: Aviation Maintenance Jacks provide a stable working lifting device for Army rotorcraft maintenance activities and enhance the occupational safety environment for maintainers.</p> <p>Obsolete item replaced by 01-541-3186</p> <table border="1" data-bbox="816 548 1357 617"> <thead> <tr> <th>FY:</th> <th>FY11</th> <th>FY12</th> <th>FY13</th> <th>FY14</th> <th>FY15</th> </tr> </thead> <tbody> <tr> <td>COST:</td> <td>\$932.72</td> <td>\$950.28</td> <td>\$966.33</td> <td>\$982.76</td> <td>\$999.46</td> </tr> </tbody> </table>	FY:	FY11	FY12	FY13	FY14	FY15	COST:	\$932.72	\$950.28	\$966.33	\$982.76	\$999.46
FY:	FY11	FY12	FY13	FY14	FY15								
COST:	\$932.72	\$950.28	\$966.33	\$982.76	\$999.46								
<p>BASIS OF ISSUE (BOI):</p> <table border="1" data-bbox="305 737 751 793"> <tr> <td>AMC</td> <td>11 per</td> </tr> <tr> <td>ASC</td> <td>Six (6) per</td> </tr> </table> <table border="1" data-bbox="394 842 695 890"> <tr> <td>LIN: L10532</td> </tr> <tr> <td>NSN: 1730-00-734-9382</td> </tr> </table>	AMC	11 per	ASC	Six (6) per	LIN: L10532	NSN: 1730-00-734-9382							
AMC	11 per												
ASC	Six (6) per												
LIN: L10532													
NSN: 1730-00-734-9382													

UNCLASSIFIED

23

Figure 20. Jack Hydraulic Tripod: 3 Ton Capacity (Aviation Ground Support Equipment Product Management Office, *AGSE Product List*, 2012)



Jack Hydraulic Tripod: 5 Ton



DESCRIPTION:

Aviation Maintenance Jacks provide a stable working lifting device for Army rotorcraft maintenance activities and enhance the occupational safety environment for maintainers.

FY:	FY11	FY12	FY13	FY14	FY15
COST:	\$4,090.00	\$4,166.98	\$4,237.37	\$4,309.41	\$4,382.67

BASIS OF ISSUE (BOI):

AMC	One (1) per
ASC	Two (2) per

LIN: L10559
NSN: 1730-00-516-2018

UNCLASSIFIED

24

Figure 21. Jack Hydraulic Tripod: 5 Ton Capacity (Aviation Ground Support Equipment Product Management Office, *AGSE Product List*, 2012)

B1 Maintenance Platform													
	<p>DESCRIPTION: Aviation Maintenance Stands provide a stable working platform for Army rotorcraft maintenance activities and enhance the occupational safety environment for maintainers.</p> <table border="1" data-bbox="818 493 1279 548"> <thead> <tr> <th>FY:</th> <th>FY11</th> <th>FY12</th> <th>FY13</th> <th>FY14</th> <th>FY15</th> </tr> </thead> <tbody> <tr> <td>COST:</td> <td>\$7,780.00</td> <td>\$7,926.43</td> <td>\$8,060.33</td> <td>\$8,197.36</td> <td>\$8,336.71</td> </tr> </tbody> </table>	FY:	FY11	FY12	FY13	FY14	FY15	COST:	\$7,780.00	\$7,926.43	\$8,060.33	\$8,197.36	\$8,336.71
FY:	FY11	FY12	FY13	FY14	FY15								
COST:	\$7,780.00	\$7,926.43	\$8,060.33	\$8,197.36	\$8,336.71								
<p>BASIS Of ISSUE (BOI):</p> <table border="1" data-bbox="378 674 722 732"> <tbody> <tr> <td>AMC</td> <td>One (1) per</td> </tr> <tr> <td>ASC</td> <td>Two (2) per</td> </tr> </tbody> </table> <table border="1" data-bbox="461 781 669 837"> <tbody> <tr> <td>LIN: M02470</td> </tr> <tr> <td>NSN: 1730-00-390-5618</td> </tr> </tbody> </table>		AMC	One (1) per	ASC	Two (2) per	LIN: M02470	NSN: 1730-00-390-5618						
AMC	One (1) per												
ASC	Two (2) per												
LIN: M02470													
NSN: 1730-00-390-5618													

UNCLASSIFIED

10

B4 Maintenance Platform													
	<p>DESCRIPTION: Aviation Maintenance Stands provide a stable working platform for Army rotorcraft maintenance activities and enhance the occupational safety environment for maintainers.</p> <table border="1" data-bbox="818 1251 1279 1306"> <thead> <tr> <th>FY:</th> <th>FY11</th> <th>FY12</th> <th>FY13</th> <th>FY14</th> <th>FY15</th> </tr> </thead> <tbody> <tr> <td>COST:</td> <td>\$8,348.00</td> <td>\$8,505.12</td> <td>\$8,648.80</td> <td>\$8,795.83</td> <td>\$8,945.36</td> </tr> </tbody> </table>	FY:	FY11	FY12	FY13	FY14	FY15	COST:	\$8,348.00	\$8,505.12	\$8,648.80	\$8,795.83	\$8,945.36
FY:	FY11	FY12	FY13	FY14	FY15								
COST:	\$8,348.00	\$8,505.12	\$8,648.80	\$8,795.83	\$8,945.36								
<p>BASIS Of ISSUE (BOI):</p> <table border="1" data-bbox="370 1404 760 1463"> <tbody> <tr> <td>AMC</td> <td>One (1) per</td> </tr> <tr> <td>ASC</td> <td>Two (2) per</td> </tr> </tbody> </table> <table border="1" data-bbox="444 1520 651 1577"> <tbody> <tr> <td>LIN: M02504</td> </tr> <tr> <td>NSN: 1730-00-294-8883</td> </tr> </tbody> </table>		AMC	One (1) per	ASC	Two (2) per	LIN: M02504	NSN: 1730-00-294-8883						
AMC	One (1) per												
ASC	Two (2) per												
LIN: M02504													
NSN: 1730-00-294-8883													

UNCLASSIFIED

11

Figure 22. Maintenance Platform: Hydraulic Adjustable Type, 3 to 7 Ft. (B1 & B4)
(Aviation Ground Support Equipment Product Management Office, AGSE
Product List, 2012)



Aviation Ground Power Unit (AGPU)



DESCRIPTION:
Semi-automatic, gas turbine engine driven, wheel-mounted, self-propelled, enclosed unit that provides ac/dc electrical, hydraulic, and pneumatic power supporting all Army rotary wing aircraft.

FY:	FY11	FY12	FY13	FY14	FY15
Unit COST:	\$1,000,000.00	\$1,018,821.30	\$1,036,032.16	\$1,053,644.71	\$1,071,556.67
AGPU Spare Parts	\$158,842.53	\$161,832.15	\$164,565.97	\$167,363.59	\$170,208.77
AGPU Consumables	\$3,329.32	\$3,391.98	\$3,449.28	\$3,507.92	\$3,567.56

BASIS OF ISSUE (BOI):

Regiment/Battalion	BOI
ARB (AH64)	3
ARS (OH58)	3
ASLT	3
GSAB	3
ASC	4
Total per CAB	16

LIN: P44627
NSN: 1730-01-552-2313

UNCLASSIFIED

12

Figure 23. Power Unit Auxiliary: Aviation Multi-Output GTED (AGPU) (Aviation Ground Support Equipment Product Management Office, *AGSE Product List*, 2012)



Aviation Shop Equipment Contact Maintenance (SECM)



DESCRIPTION:
Contact Maintenance Vehicle (M1079A1P2 Van) for transporting a crew of three and mission essential equipment, expendable supplies, spares, and repair parts to fix or recover downed helicopters.

FY:	FY11	FY12	FY13	FY14	FY15
COST:	TBD	TBD	TBD	TBD	TBD

BASIS OF ISSUE (BOI):

Regiment/Battalion	BOI
ARB (AH64)	4
ARS (OH58)	4
ASLT	4
GSAB	5
ASC	6
Total per CAB	23
TDA	13
SOAR	44
ORF	34
AVCRAD	4
Auth SECMs Total	595

LIN: S30224
NSN: 4920-015-548-2315

UNCLASSIFIED

13

Figure 24. Shop Equipment Contact Maintenance (SECM): Aviation (Shelter Only—Non-Modernized) (Aviation Ground Support Equipment Product Management Office, *AGSE Product List*, 2012)



AVIATION SYSTEM SUPPORT OFFICE
THESE COLORS NEVER RUN
AGSO

Pitot Static Test Set (PSTS)



AGSE



DESCRIPTION:
A lightweight, man-portable tester which provides the capability of troubleshooting, repairing, and verifying proper operation of flight critical aircraft air data systems.

FY:	FY11	FY12	FY13	FY14	FY15
COST:	\$48,722.00	\$49,639.01	\$50,477.56	\$51,335.68	\$52,208.38
Spares	\$6687.00	\$6812.86	\$6927.95	\$7045.72	\$7165.50

BASIS Of ISSUE (BOI):

AMC	One (1) per flight company supported
ASC	Two (2) sets per
AVCRAD	Two (2) sets per

LIN: T03597
NSN: 4920-01-388-6790
P/N: ADTS405-8159-01
Model: TS-4463/P

UNCLASSIFIED 8

Figure 25. Tester: Pitot and Static Systems TS-4463/P (Aviation Ground Support Equipment Product Management Office, *AGSE Product List*, 2012)



Aviation Vibration Analyzer (AVA)



	<p>DESCRIPTION: AVA Provides a rugged, portable, and safe means of performing helicopter, one per revolution (1P) maintenance, for both main and tail rotors. Measures, records, and processes vibration and blade position information to diagnose and present measurement, diagnostic, and corrective information to maintenance personnel to correct faults.</p> <table border="1" data-bbox="842 558 1396 659"> <thead> <tr> <th>FY:</th> <th>FY11</th> <th>FY12</th> <th>FY13</th> <th>FY14</th> <th>FY15</th> </tr> </thead> <tbody> <tr> <td>COST:</td> <td>\$24,200.00</td> <td>\$24,855.48</td> <td>\$25,071.98</td> <td>\$25,498.20</td> <td>\$25,931.67</td> </tr> <tr> <td>Spares</td> <td>\$7746.72</td> <td>\$7892.52</td> <td>\$8025.85</td> <td>\$8182.29</td> <td>\$8301.05</td> </tr> </tbody> </table>	FY:	FY11	FY12	FY13	FY14	FY15	COST:	\$24,200.00	\$24,855.48	\$25,071.98	\$25,498.20	\$25,931.67	Spares	\$7746.72	\$7892.52	\$8025.85	\$8182.29	\$8301.05
FY:	FY11	FY12	FY13	FY14	FY15														
COST:	\$24,200.00	\$24,855.48	\$25,071.98	\$25,498.20	\$25,931.67														
Spares	\$7746.72	\$7892.52	\$8025.85	\$8182.29	\$8301.05														
<p>BASIS OF ISSUE (BOI):</p> <table border="1" data-bbox="272 772 812 850"> <tbody> <tr> <td>AMC</td> <td>Two (2) per flight company supported</td> </tr> <tr> <td>ASC/AVCRAD</td> <td>Four sets (4) per</td> </tr> </tbody> </table> <table border="1" data-bbox="435 894 701 968"> <tbody> <tr> <td>LIN: T53635</td> </tr> <tr> <td>NSN: 6625-01-282-3746</td> </tr> </tbody> </table>	AMC	Two (2) per flight company supported	ASC/AVCRAD	Four sets (4) per	LIN: T53635	NSN: 6625-01-282-3746													
AMC	Two (2) per flight company supported																		
ASC/AVCRAD	Four sets (4) per																		
LIN: T53635																			
NSN: 6625-01-282-3746																			

UNCLASSIFIED

16

Figure 26. Test Set: Aviation Vibration Analyzer (AVA) (Aviation Ground Support Equipment Product Management Office, *AGSE Product List*, 2012)



Aviation Foot Locker (AFL)

	<p>DESCRIPTION: The AFL are Team aviation mechanics tool kit containers, Aerospace Standard tools, foam shadowed drawers and a component listing with picture diagrams for ease of inventory and to minimize foreign object damage to aircraft</p> <table border="1"> <thead> <tr> <th>FY:</th> <th>FY11</th> <th>FY12</th> <th>FY13</th> <th>FY14</th> <th>FY15</th> </tr> </thead> <tbody> <tr> <td>COST:</td> <td>\$8,120.00</td> <td>\$8,272.83</td> <td>\$8,412.58</td> <td>\$8,555.60</td> <td>\$8,701.04</td> </tr> </tbody> </table>	FY:	FY11	FY12	FY13	FY14	FY15	COST:	\$8,120.00	\$8,272.83	\$8,412.58	\$8,555.60	\$8,701.04
FY:	FY11	FY12	FY13	FY14	FY15								
COST:	\$8,120.00	\$8,272.83	\$8,412.58	\$8,555.60	\$8,701.04								
<p>BASIS OF ISSUE (BOI):</p> <table border="1"> <tr> <td>AMC</td> <td>Two sets (2) per</td> </tr> <tr> <td>ASC</td> <td>Two sets (2) per</td> </tr> <tr> <td>AVCRAD</td> <td>Two sets (2) per</td> </tr> </table> <p>LIN: T65997 NSN: 4920-01-377-5412</p>	AMC	Two sets (2) per	ASC	Two sets (2) per	AVCRAD	Two sets (2) per							
AMC	Two sets (2) per												
ASC	Two sets (2) per												
AVCRAD	Two sets (2) per												

UNCLASSIFIED

18

Figure 27. Tool Set: Aviation Foot Locker—Man Portable SPT PM ACFT (Aviation Ground Support Equipment Product Management Office, *AGSE Product List*, 2012)



**Unit Maintenance Aerial Recovery Kit
(UMARK)**





DESCRIPTION:
Provides ASCs and ASBs the ability to quickly rig disabled non-flyable aircraft or aircraft undergoing maintenance for airlift evacuation

FY:	FY11	FY12	FY13	FY14	FY15
COST:	\$148,000.00	\$150,785.55	\$153,332.76	\$155,939.42	\$158,590.39

BASIS OF ISSUE (BOI):

GSAB	Two (2) per
AMC	One (1) per
ASC	Two (2) per
AVCRAD	Two (2) per

LIN: U87773
NSN: 1670-01-501-8140
P/N: 94J500-4

UNCLASSIFIED

15

Figure 28. Unit Maintenance Aerial Recovery Kit (UMARK) (Aviation Ground Support Equipment Product Management Office, *AGSE Product List*, 2012)



**AVIATION SYSTEMS
PRODUCT OFFICE**

THOSE WE SERVE
NEVER
FORGET

Fuel Quantity Test Set (FQTS)



Let's Fly, Let's Go
AGSE
No One's Left Behind



DESCRIPTION:
Fuel Quantity Test Set (FQTS) is used to calibrate and troubleshoot any alternating current, capacitive fuel, oil or liquid oxygen quantity system.

- Measures capacitance
- Measures insulation resistance
- Simulates one or two capacitors
- Completely portable – battery powered
- Lightweight aluminum case

FY:	FY11	FY12	FY13	FY14	FY15
COST:	\$6,150.00	\$6,265.75	\$6,371.60	\$6,479.91	\$6,590.07
Spares	\$6109.00	\$6223.98	\$6329.12	\$6436.72	\$6546.14

BASIS OF ISSUE (BOI):

AMC	Two (2) sets per
ASC	Two (2) sets per
AVCRAD	Two (2) sets per

LIN: FG2507
NSN: 6625-01-297-5305

REMARKS:

UNCLASSIFIED

9

Figure 29. Test Set ACFT Fuel Quantity Gauge and Indicator: Portable (Aviation Ground Support Equipment Product Management Office, *AGSE Product List*, 2012)



AVIATION GROUND SUPPORT EQUIPMENT
THEY GO WHERE WE GO
WE FLY THEM

Aircraft Tow Bar



AGSE
AGSE



DESCRIPTION:
Aircraft Tow Bar used for relocating Army rotorcraft to facilitate maintenance activities and enhance the occupational safety environment for maintainers.

FY:	FY11	FY12	FY13	FY14	FY15
COST:	\$1,021.00	\$1,040.22	\$1,057.79	\$1,075.77	\$1,094.06

BASIS OF ISSUE (BOI):

ASC LT/MED	Three (3) per
ASC Heavy	Four (4) per

LIN: W69391
NSN: 1730-00-967-9556

UNCLASSIFIED 25

Figure 30. Towbar Motor Vehicle: Wheeled Vehicle (Aviation Ground Support Equipment Product Management Office, *AGSE Product List*, 2012)



**Standard Aircraft Towing System
(SATS)**





DESCRIPTION:
Standard aircraft towing system that has the capability to reposition all U.S. Army rotary wing aircraft.

FY:	FY11	FY12	FY13	FY14	FY15
Unit COST:	\$50,242.00	\$52,000.00	\$53,824.00	\$53,824.00	\$53,824.00
Field Support Kit	\$343.00	\$349.46	\$355.36	\$361.40	\$367.54
Prescribed Load List (PLL)	\$1,585.89	\$1,615.74	\$1,643.03	\$1,670.96	\$1,699.37
Authorized Stockage List (ASL)	\$9,700.47	\$9,883.05	\$10,050.00	\$10,220.85	\$10,394.60

BASIS OF ISSUE (BOI):

Regiment/Battalion	BOI
ATTACK/ ARS (X2) (OH58)	3
ASLT	3
ACS	3
GSAB	3
ASC	4
Total per CAB	16

LIN: S21580
NSN: 1740-01-575-5662

UNCLASSIFIED

Figure 31. Tractor Wheeled Aircraft Towing: Gas Operated (Aviation Ground Support Equipment Product Management Office, *AGSE Product List*, 2012)

LIN: W93995, TRAIL ACFT MAIN ARMBL

NSN: 1730-01-086-1653

TM 55-1730-224-13&P

Cost: \$2,652.00

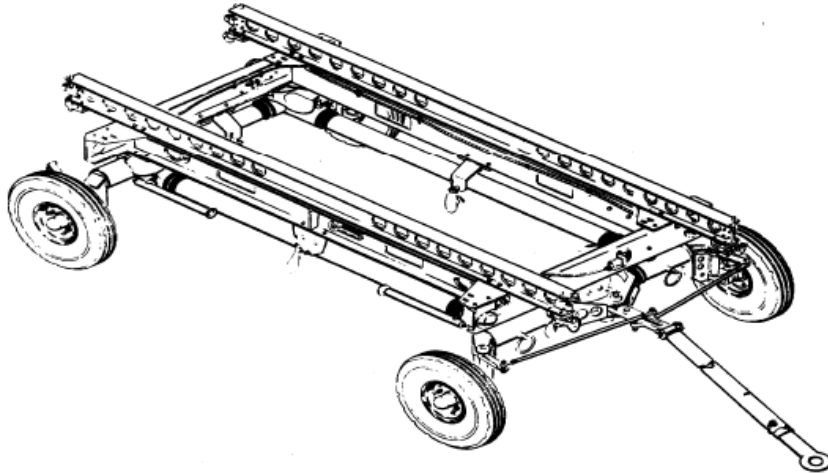

1

Figure 32. Trailer ACFT Main Airmobile: 4 Wheeled 30/48 In. TRF Rail System (Chief, TASM-E, personal communication, April 18, 2012)

THIS PAGE INTENTIONALLY LEFT BLANK

LIST OF REFERENCES

- Arms Export Control Act (AECA), 22 U.S.C. ch. 39 (1976).
- “Authority to transfer excess defense articles,” 22 U.S.C. § 2321j (2000). Retrieved from, <http://www.law.cornell.edu/uscode/text/22/2321j>
- Aviation Ground Support Equipment Product Management Office, (2012). *AGSE Product List*. Huntsville, AL: U.S. Army.
- Brand, T., Kraag, A., Brage, L., & Rahman, S. (2012, April). How can a NATO SOF air wing best support NATO Special Operations? A ground operator’s perspective. In A. D. Davis & K. D. Yoho (Eds.), *The NATO Special Operations Headquarters Air Warfare Center: A smart defense approach*. Monterey, CA: Naval Postgraduate School.
- The Boeing Company. (n.d.). CH-47D/F overview. Retrieved from <http://www.boeing.com/rotorcraft/military/ch47d/index.htm>
- Cargo Helicopters Project Management Office. (2012, April 3). *Cargo Helicopters Update*. Briefing at Army Aviation Association of America Professional Symposium. Nashville, TN.
- Cervantes, M., Enderton, C., & Powers, J. (2012, April). Near term rotary wing aviation needs: Acquisition and program management of excess defense articles. In A. D. Davis & K. D. Yoho (Eds.), *The NATO Special Operations Headquarters Air Warfare Center: A smart defence approach*. Monterey, CA: Naval Postgraduate School.
- CH-47 Helicopter data. (n.d.) *Jane’s Defense*. Retrieved from http://client.janes.com.libproxy.nps.edu/janesdata/yb/jau/jau_1464.htm#toclink-j0010100032067
- Chairman of the Joint Chiefs of Staff (CJCS). (2000, April 6). *Doctrine for logistic support of joint operations* (JP 4-0). Washington, DC: Author.
- Defense Acquisition University (DAU). (n.d). Acquisition Community Connection web-portal. Retrieved from <https://acc.dau.mil/CommunityBrowser.aspx?id=18073>
- Defense Institute of Security Management (DISAM). (2010). *The Management of Security Assistance*. Retrieved from <http://www.dsca.osd.mil/pubs/29thgbookv2.pdf>

- Defense Security Cooperation Agency (DSCA). (n.d.). *Defense Security Cooperation Agency* (DoD 5105.38-M). Retrieved from <http://www.dsca.mil/>
- Defense Security Cooperation Agency (DSCA). (2008). Excess defense articles. Retrieved from <http://www.dsca.mil/programs/eda/edamain.htm>
- Defense Security Cooperation Agency (DSCA). (2012, April 30). *Security assistance management manual* (DoD 5105.38-M). Retrieved from <http://www.dsca.mil/samm/ESAMM/C09/9.05.htm>
- Department of Defense (DoD). (1997, August 18). *Defense materiel disposition manual* (DoD 4160.21-M). Washington, DC: DoD.
- Department of Defense (DoD). (2011a, December 31). *Selected acquisition report: CH-47F*. Retrieved from http://www.dod.gov/pubs/foi/logistics_materiel_readiness/acq_bud_fin/SARs/DEC%202011%20SAR/CH-47F%20-%20SAR%20-%2031%20DEC%202011.pdf
- Department of Defense (DoD). (2011b, December 31). *Selected acquisition report: UH-60M Black Hawk*. Retrieved from http://www.dod.mil/pubs/foi/logistics_materiel_readiness/acq_bud_fin/SARs/DEC%202011%20SAR/UH-60M%20BLACK%20HAWK%20-%20SAR%20-%2031%20DEC%202011.pdf
- Diwa, M. (2011, July 23). *NATO SOF headquarters*. Briefing presented at the Naval Postgraduate School, Monterey, CA.
- Foreign Assistance Act (FAA), 22 U.S.C. § 2151 (1961).
- Global Security.org. (n.d.). Office of the Program Manager, Saudi Arabia National Guard Modernization Program. Retrieved from <http://www.globalsecurity.org/military/agency/dod/opm-sang.htm>
- Historical inflation rates. (n.d.). Retrieved May 24, 2012, from <http://www.inflationdata.com>
- Joint Chiefs of Staff Commissioned Special Operations Review Group. (1980). *The Holloway Commission report*. Washington, DC: Joint Chiefs of Staff.
- Lok, J. J. (2007, November 27). NATO short of helicopters for Afghanistan. *Aviation Week & Space Technology*.
- Marion, R. (2012, April 2). *CARGO Helicopters PM update*. Briefing presented at the Army Aviation Association of America Professional Symposium, Nashville, TN.

- NATO. (n.d.). In *Wikipedia*. Retrieved March 2012
from <http://en.wikipedia.org/wiki/NATO>
- NATO Enlargement Facilitation Act of 1996, Pub. L. No. 104-208, § 1830, 110 Stat. 3009 (1996).
- North Atlantic Treaty Organization (NATO). (n.d.). NATO Airlift Management Agency. Retrieved from <http://www.nama.nato.int/Press-01-04-2011.html>
- North Atlantic Treaty Organization (NATO). (2007). *Riga Summit reader's guide*. Retrieved from http://www.nato.int/nato_static/assets/pdf/pdf_publications/20120117_rdr-gde-riga-e.pdf
- North Atlantic Treaty Organization (NATO) Special Operations Headquarters. (2010, April 22). *Special Operations Air Group: Concept for development & organization*. Brussels, Belgium: NATO Public Policy Division.
- Prater, L. M. (Ed). (2010, January). *The management of security assistance* (29th ed.). Retrieved from <http://www.dsca.mil/pubs/29th%20Gbookv2.pdf>
- Sikorsky Aircraft Corporation. (n.d.). UH-60 overview. Retrieved from <http://www.sikorsky.com/Products>
- UH-60 Helicopter data. (n.d.). *Jane's Defense*. Retrieved from <http://client.janes.com.libproxy.nps.edu/janesdata/yb/jawa/jawa1457.htm#toclink-j0010120164447>
- Under Secretary of Defense for Acquisition, Technology, and Logistics (USD[AT&L]). (2008, December 8). *Operation of the defense acquisition system* (DoD Instruction 5000.02). Washington, DC: Author.
- United States Army. (n.d.a). CH-47 Chinook fact file. Retrieved from <http://www.army.mil/factfiles/equipment/aircraft/chinook.html>
- United States Army. (n.d.b). UH-60 Black Hawk fact file. Retrieved from <http://www.army.mil/factfiles/equipment/aircraft/blackhawk.html>
- United States Army. (1995, November 15). *Requisitioning, receipt, and issue system* (AR 725-50). Retrieved from http://www.apd.army.mil/pdf/files/r725_50.pdf
- United States Army, Program Executive Office Aviation. (2012, April 18). *Army aircraft divestiture standard operating procedure* (Ver. 1). Redstone Arsenal, AL: U.S. Army

United States Navy. (n.d.). SH-60 Sea Hawk gallery. Retrieved from
http://www.navy.mil/gallery_search_results.asp

Utility Helicopters Project Management Office. (2012, April 3). *Utility helicopters update*. Briefing at Army Aviation Association of American Professional Symposium. Nashville, TN.

INITIAL DISTRIBUTION LIST

1. Defense Technical Information Center
Ft. Belvoir, Virginia
2. Dudley Knox Library
Naval Postgraduate School
Monterey, California
3. Dr. Keenan Yoho
United States Special Operations Command
Tampa, Florida
4. Dr. Leo Blanken
Naval Post Graduate School
Monterey, California
5. Lt Col. Mike Maksimowicz
NATO Special Operations Headquarters
SHAPE, Belgium
6. LTC Manny Diwa
NATO Special Operations Headquarters
SHAPE, Belgium