

Navy Experimental Diving Unit
321 Bullfinch Rd.
Panama City, FL 32407-7015

TA 04-15 & 09-05
NEDU TR 11-13
June 2011

THE DESIGN AND DEVELOPMENT OF THE TOPSIDE DECOMPRESSION MONITOR

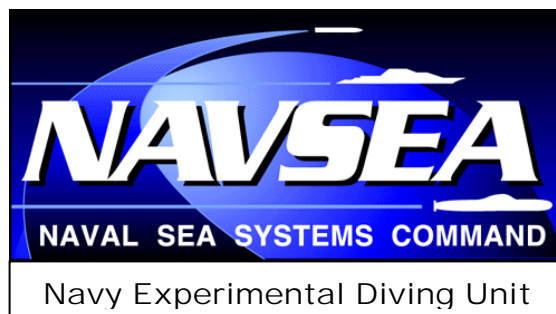

Author: Henry Boone

Distribution Statement A:
Approved for public release;
distribution is unlimited.

REPORT DOCUMENTATION PAGE			<i>Form Approved</i> <i>OMB No. 0704-0188</i>	
Public reporting burden for this collection of information is estimated to average 1 hour per response, including the time for reviewing instructions, searching existing data sources, gathering and maintaining the data needed, and completing and reviewing this collection of information. Send comments regarding this burden estimate or any other aspect of this collection of information, including suggestions for reducing this burden to Department of Defense, Washington Headquarters Services, Directorate for Information Operations and Reports (0704-0188), 1215 Jefferson Davis Highway, Suite 1204, Arlington, VA 22202-4302. Respondents should be aware that notwithstanding any other provision of law, no person shall be subject to any penalty for failing to comply with a collection of information if it does not display a currently valid OMB control number. PLEASE DO NOT RETURN YOUR FORM TO THE ABOVE ADDRESS.				
1. REPORT DATE June 2011	2. REPORT TYPE Technical Report	3. DATES COVERED (From - To) FROM Aug 04 TO Feb 11		
4. TITLE AND SUBTITLE The Design and Development of the Topside Decompression Monitor		5a. CONTRACT NUMBER		
6. AUTHOR(S) Henry Boone		5d. PROJECT NUMBER		
		5e. TASK NUMBER 04-15 & 09-05		
		5f. WORK UNIT NUMBER		
7. PERFORMING ORGANIZATION NAME(S) AND ADDRESS(ES) Navy Experimental Diving Unit 321 Bullfinch Rd Panama City, FL 32407-7015		8. PERFORMING ORGANIZATION REPORT NUMBER NEDU Technical Report No. 11-13		
9. SPONSORING / MONITORING AGENCY NAME(S) AND ADDRESS(ES) NAVSEA		10. SPONSOR/MONITOR'S ACRONYM(S)		
		11. SPONSOR/MONITOR'S REPORT NUMBER(S)		
12. DISTRIBUTION / AVAILABILITY STATEMENT A: Approved for public release; distribution is unlimited.				
13. SUPPLEMENTARY NOTES				
14. ABSTRACT In 2004 Navy Experimental Diving Unit was tasked to prototype a dive data collection and management system. As a "topside decompression monitor" (TDM), the system must be able to operate at remote diving locations and provide dive supervisors and operators with real-time dive decompression information. The TDM will collect diver depth and temperature information and update this into its TDM topside computer, which has been programmed to provide real-time decompression schedules for the diver(s). TDM hardware components include a laptop computer, instrumentation case, diver instrumentation cable, and diver-worn depth sensor; its software components include a decompression program and a data management program. Special permission is currently obtained to actively use the TDM in an ongoing diving operation. The TDM monitors diver depth, computes real-time decompression profiles, and provides information to dive supervisors and operators, so that they can act to ensure the safety of the divers. The TDM is in the field and is being received in a positive manner by dive supervisors and operators using the system.				
15. SUBJECT TERMS Topside Decompression Monitor, TDM				
16. SECURITY CLASSIFICATION OF: Unclassified		17. LIMITATION OF ABSTRACT	18. NUMBER OF PAGES	19a. NAME OF RESPONSIBLE PERSON NEDU Librarian
a. REPORT	b. ABSTRACT	c. THIS PAGE	22	19b. TELEPHONE NUMBER (include area code) 850.230.3170

CONTENTS

	<u>Page No.</u>
Standard Form 298	i
CONTENTS	ii
INTRODUCTION.....	1
DEVELOPMENT AND DESIGN REQUIREMENTS OF THE TDM	1
Computer Requirements	1
Sensor Instrumentation Case	1
Diver Instrumentation Cable	1
Diver-Worn Depth Sensor	2
Field Sensor Verification System.....	2
BUILDING THE TDM	2
Laptop Computer.....	2
Sensor Instrumentation Case	2
Battery	3
Power Supply and Battery Charger	3
Sensor Power Switch.....	3
Indicator Lights	3
Connectors	3
Ground Fault Circuit Interrupter	4
Diver Instrumentation Cable	4
Telemetry Cable CE1C/9-100UC.....	4
Subsea Cable CE-3T-6-100UC	5
Diver-Worn Depth Sensor	7
Field/Sensor Verification System.....	7
DISCUSSION AND RECOMMENDATIONS	8
Laptop Computer.....	8
Sensor Instrumentation Case	8
Battery	8
Power Supply and Battery Charger	9
Connectors	9
Diver Instrumentation Cable	9
Diver-Worn Depth Sensor	10
Field/Sensor Verification System.....	10
CONCLUSION	10
APPENDIX — TDM Pictures and Diagrams	
Field/Sensor Verification System (SVS) front panel	A-1
Field/Sensor Verification System (SVS) layout of components and functions... ..	A-2
Instrumentation layout of SIC	A-3
Diagram of SIC wiring.....	A-4
BULGIN Circular Connector, Buccaneer Series.....	A-5
PPTR depth sensor wiring pin out.....	A-6
Diver-worn Depth Sensor (DWDS).....	A-7

SIC view of top plate A-8
SIC and 350 ft DIC with DWDS attached A-9

Figures

Figure 1. Cable CE1C/9 cut away view of wire strand..... 4
Figure 2. CE-3T-6-100UC design view of wire strands..... 6

INTRODUCTION

In 2004 the Navy Experimental Diving Unit (NEDU) was tasked to prototype a dive data collection and management system. This report provides an overview of the design, development, and instrumentation support for the Topside Decompression Monitor (TDM).

DEVELOPMENT AND DESIGN REQUIREMENTS OF THE TDM

The TDM is composed of five sections or subassemblies: a laptop computer, an instrumentation case, an instrumentation cable, a depth sensor, and a depth sensor verification system. Since the TDM is to be operated in extreme outdoor environments and conditions, the following are some of the design considerations and requirements for its equipment and instrumentation.

Computer requirements: A laptop computer is the primary data collection and management platform to be used with the TDM. This laptop must have USB and Ethernet connectivity, as well as a serial port connection that can be used for RS485/RS232 digital interface. It should also have adequate memory and processor speed for running decompression profiles in real time, a touch screen, a rugged design and build for extreme outdoor environments, and an ability to operate for extended time periods — often up to eight hours.

Sensor Instrumentation Case: As the central point for the TDM, the sensor instrumentation case (SIC) houses all the necessary instrumentation circuits to support dive data collection from three separate divers. Included in the design are power supplies, sensor and power connection points, and batteries that support all functions of the TDM and its laptop computer. Designed, built, and sized for transport or travel with the operator of the system, the case must also be able to withstand extreme outdoor conditions. The SIC should have the capability to operate with power sources of 90–240 VAC, 50–65 Hz, or 12–32 VDC input. Proper techniques for shielding signals and for protecting and isolating power circuits should ensure operator and diver safety.

Diver Instrumentation Cable: The diver instrumentation cable (DIC) should be of such a design and make that it can be used for instrumentation and digital signals that support the TDM's diver depth sensor. It should be properly shielded and have adequate conductors for RS485 (full and half duplex), RS232, and 0–20 mA current instrumentation signals. Additional DIC cable requirements and features should include a durable outer cable jacket and have water blocking inside the cable, strength members, and shielding — and should be able to withstand the extreme diving environments in which the cable will be used. If the cable is to be married into the full length of a standard USN diver umbilical, the cable should lie alongside the other cables and hoses without offering an extreme profile or bulge. The topside plug connector on the DIC will plug into its mated bulkhead receptacle mounted on or in the SIC. The diver end of the DIC will have a molded/potted submersible female connector and a positive locking sleeve that securely connects it to the diver-worn depth sensor

(DWDS). The DIC's overall length can vary according to diving requirements and various equipment configurations: Typical DIC lengths could be 350–400 feet and 650–700 feet.

Diver-Worn Depth Sensor: The DWDS will be a VDC-powered submersible digital pressure transducer that can communicate over a (RS232/RS485) serial bus. This sensor should have $\pm 0.1\%$ full-scale accuracy between 28 °F and 128 °F operating temperatures and have built-in electrical shock protection. A submersible male connector that will mate to the DIC submersible connector will be molded into the sensor body. The sensor will have a threaded connection at its port opening, a connection that will allow the sensor to be calibrated and a protective cap to be attached to prevent it from being damaged. The sensor's depth range will be from 0 to 165 PSIA, a range which can provide a depth capability to >325 feet of seawater (fsw), with a resolution of ± 0.1 fsw. The DWDS should have a built-in temperature sensor (having a range of 28 °F to 128 °F with ± 1.0 °F accuracy) that can transmit diver water temperatures to the TDM. Each DWDS will have a unique identification code that will allow the sensor to be "tagged" to a diver for tracking purposes. Upon receiving a request command from the TDM via the serial bus, the DWDS's electronics must be able to update its pressure and temperature information in approximately 50 msec.

Field/Sensor Verification System: The field/sensor verification system (SVS) will serve as a pre- or postdive sensor check to verify that the sensor is working correctly at the dive site: A reading from a small portable pressure device or pressure source would be compared one-to-one to that from the DWDS sensor. The sensor's response would be compared to its primary linearity check, and the system would respond with a pass or fail message. This procedure will thus ensure the integrity of the sensor and verify the acceptability of continuing dive preparations.

BUILDING THE TDM

Laptop Computer: The laptop/portable computer selected for use with the TDM is a PANASONIC TOUGHBOOK, Model CF-29, with TDM decompression software loaded on it. Support equipment for the CF-29 includes a primary and a secondary battery, a DVD/CDRW drive, external battery chargers, auto/air AC adapters and power cords, and standard operating system software packages.

Manufacturer/Model: PANASONIC, Model CF-29 TOUGHBOOK
(Panasonic Toughbook; Sales 1-888-223-1012, toughbook _ sales _ support_ @
us.panasonic.com)

Sensor Instrumentation Case (SIC): A protective instrument case built by Pelican Case, Inc., Model 1600 case, was chosen to house the TDM instrumentation. Some minor modifications to this Pelican case include fabrication of an aluminum plate to be mounted on the inside bottom of the case. This plate provides a base to mount power supplies, batteries, a cooling fan, signal circuit boards, and other support instrumentation. Another aluminum plate fits inside the top portion of the Pelican case, and circuit protection switches — along with various indicators, LED lights

(ON/OFF/CHARGING), and control switches for the power supplies — are mounted to this top plate. Additional modifications to the outside of the case include placements of connectors for the diver instrumentation cables and of tie down points for relief of cable strain.

Manufacturer/Model: PELICAN CASE, Model 1600 case (9905 Perrin Beitel, San Antonio, TX 78217; 800-666-6200, Pelican-Case.com)

Battery: Two 12 VDC-12 AH/20HR sealed absorption glass mat (AGM) batteries were installed into the SIC as a parallel connection. This battery arrangement should provide approximately eight hours of run time to support the TDM operation. The batteries are also not restricted for passenger or cargo aircraft, and they meet air transportation requirements specified in DOT 49 CFR173.159, IATA (International Air Transport Association) and ICAO (International Civil Aviation Organization).

Manufacturer/Model: MK POWERED ES12-12 (MK battery: 1631 South Sinclair Street • Anaheim, CA 92806 • tel: 800-372-9253, 714-937-1033, fax: 714-937-0818 email: sales@mkbattery.com)

Power Supply and Battery Charging: Two power factor–corrected (PFC) 100 W single-output power supplies were installed into the SIC. Each one can operate with an input voltage range of 85–264 VAC @ 47–63 Hz, and they are used to recharge the batteries and provide additional VDC power as needed. They are wired parallel to provide battery charging capability, if one power supply fails.

Manufacturer/Model: MEANWELL SP-100 Series SP-100-12 North American Office, Mean Well USA, Inc., 44030 Fremont Blvd., Fremont, CA 94538, Tel: 510-683-8886, Fax: 510-683-8899, mwsales@meanwellusa.com, <http://www.meanwellusa.com>

Sensor Power Switch: SPST (ON/OFF), IP68-rated. Used to provide power to the pressure sensor, this switch is mounted on the top panel and should be IP67/68 rated. IP (Ingress Protection or International Protection) ratings are part of a classification system showing the degrees of protection from solid objects and liquids.

Indicators/Lights: LED, IP68-rated. These LED lights/indicators indicate when the primary mains power is active. They also show that the internal power supplies are charging the batteries and VDC power is available for use to support the TDM functions.

Manufacturer/Model: BULGIN – DX0505 LED Indicators (red, green, yellow, blue). Purchase information: www.NEWARK.com (800-463-9275).

Connectors: Various connectors that would not allow cross connection of sources were selected: three contacts for AC power, two contacts for DC power, six contacts for data, and so forth. When mated, these connectors are water- and dustproof to IP68, and have a compact design with sealing caps available to maintain an IP68 rating of unmated connectors. Each connector has positive locating keyways: each cannot be misconnected and is “easy assembly” — prewired and over molded cable assemblies.

Manufacturer/Model: BULGIN Circular Connector, Buccaneer Series, IP68-rated. Purchase information: www.NEWARK.com (800-463-9275).

SUBCONN submersible MCIL6F and MCIL6M connectors are used to attach the depth sensor to the cable.

Manufacturer/Model: SubConn Inc., P.O. Box 328, North Pembroke, MA 02358, USA, Tel: +1 781 829 4440, Fax: +1 781 829 4442
mac-us@macartney.com ww.subconn.com

Ground Fault Circuit Interrupter (GFIC)/Residual Current Devices (RCDs): Industrial circuit protection (ICP) for the SIC is provided by a GFIC/RCD single-input device. The main power sources may vary between 85 and 264 VAC @ 47–63 Hz, depending on local main power being supplied, and this ICP will act as the primary ON/OFF and GFIC/RCD protection. A protective cover was fabricated to maintain an IP68 rating protection for the ICP device.

Manufacturer/Model: LEGRAND USA, 60 Woodlawn Street, West Hartford, CT 06110, Tel: 877-295-3472.

Diver Instrumentation Cable: After all aspects of the design, construction, and intended use of diver instrumentation cables (DICs) were considered, two existing cable assemblies obtained from CHALCO ELEVEN were selected for use. A BULGIN 6-pin male connector was attached to the topside end of the cable, and a SUBCONN 6-pin submersible/waterproof female connector was molded onto the in-water end of the cable. Both cable assemblies are of similar design and construction, and they are successfully being used in the field. A 350-foot length of cable weighs approximately 30 pounds.

Manufacturer/Model: CHALCO ELEVEN LTD., Maryculter, Aberdeen, AB12 5GQ, U.K., Tel: (44)-(0)-1224 733321 FAX (44)-(0)-1224 733685
E-Mail: ce@chalco.co.uk www.chalco.co.uk

Telemetry Cable CE1C/9-100UC: With its unique characteristics of copper and silver and with very low losses over long distances, the CE1C/9-100UC telemetry cable is specially designed for use in hyperbaric chambers. If the cable is cut, it will reseal itself. It can be cleaned with virtually any chemical and does not embolize at depth. It will work in mixed gases and is durable yet flexible.

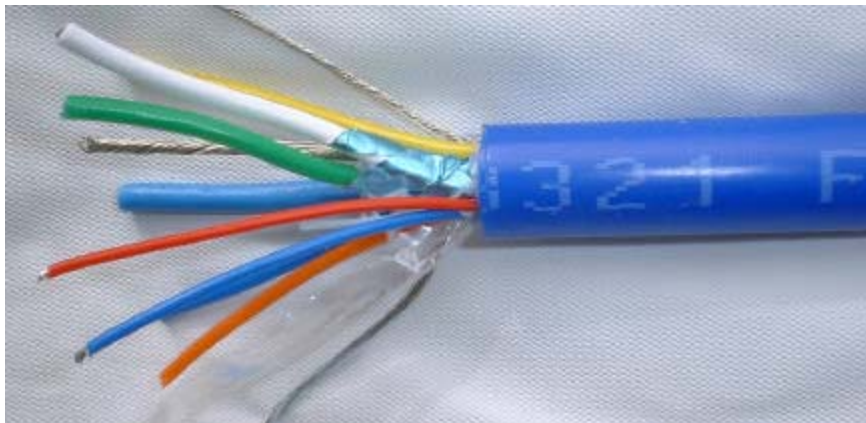

Figure 1. Cable CE1C/9 cut away view of wire strands

Physical Details:

1 x 75 ohm	Low-loss mini coax
1 x 1.34 mm ²	Twisted screen pair
1 x 0.5 mm ²	Twisted screen pair
1 x 1.34 mm ²	Conductor
1 x 0.22 mm ²	Twisted pair
1 x 0.22 mm ²	Overall screen

Inner cable voids are filled with a compound of water-blocking silicon rubber/glass microspheres. If the outer sheath is cut, the compound stops the water from travelling up the cable.

Mechanical Properties:

Outer sheath	blue polyurethane
Final outside diameter	11 mm
Outer thickness of sheath	2.0 mm
Weight of cable in air	130 kg/km
Weight of cable in seawater	50 kg/km
Minimum static bend radius	165 mm
Minimum dynamic bend radius	220 mm
Maximum continuous length	5000 meters
Assuming seawater density	1026 kg/m

Subsea Cable CE-3T-6-100UC: The CE-3T-6-100UC subsea and topside cable is manufactured from a 2 mm polyurethane outer sheath and multistrand copper cores. An individually twisted pair can be used for video, data, communication, low power, or telemetry. This cable is specially designed for use in hyperbaric chambers, diving bells, or ROVs. It can also be twisted into divers' umbilicals or used for interconnecting saturation chamber complexes. It will work subsea, topside, and in mixed gases, and it is durable yet flexible. With its unique characteristics of copper and silver, it suffers very low losses over a long distance. The cable can be supplied to a customer's desired length, with the maximum being 5 km. The CE-3T-6-100UC cable voids are filled with a water-blocking silicon rubber/glass microspheres compound. If the outer sheath is cut, the compound stops the water from travelling up the cable.

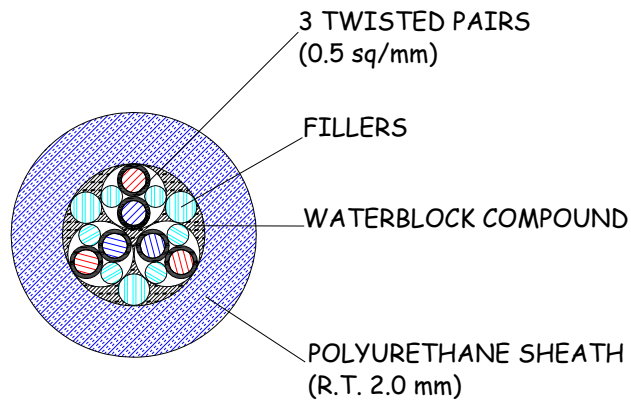

Figure 2. CE-3T-6-100UC design view of wire strands

Physical Details:

Approximate Diameter	11.2 mm (± 1.0 mm)
Laid-up size of cable	7.2 mm
Polyurethane sheath	2.0 mm
Weight of cable in air	138.4 kg/km
Weight of cable in water	37.4 kg/km

Bend Radius:

Static	89 mm
Dynamic	134 mm

Cable Construction:

3 twisted pair (0.5 mm^2) + water-block compound + polyurethane sheath (R.T. 2.0 mm)

Electrical Details:

Working voltage	500 V
Maximum conductor resistance	40.1 ohms/km
Insulation resistance core to core	>500 m/ohms/km

Mechanical Properties:

Outer sheath	blue polyurethane
Final outside diameter	11.2 mm
Outer thickness of sheath	2.0 mm
Minimum static bend radius	165 mm
Minimum dynamic bend radius	220 mm
Assuming seawater density	1026 kg/m

Component Details:

Insulated core diameter	1.6 mm
Diameter of T.S.P.	3.3 mm

(These cable parameters are listed from the CHALCO Web site.)

Diver-worn Depth Sensor: The Honeywell Model PPTR0300AP5VB Precision Pressure Transducer (PPT), which provides high-accuracy pressure readings in both digital and analog forms, was selected for the diver-worn depth sensor (DWDS). The heart of this PPT measuring system is a silicon piezoresistive sensor that contains both pressure- and temperature-sensitive elements. Digital signals representing temperature and pressure are processed by a microprocessor to produce pressure readings fully temperature compensated and calibrated over the entire -40 to 85 °C temperature range. The PPT receives commands and sends data from either an RS-232 port or a multidrop RS-485 port. The RS-485 PPT allows up to 89 PPTs to be connected to a two-wire multidrop bus, when bus repeaters are used to satisfy the RS-485 bus electrical requirements. Group (multicast) addressing allows up to nine groups of PPTs to be addressed with a single command. Global (broadcast) addressing will send a command to all PPTs on the serial bus. To allow the user to select baud rates, sample rates, readout resolution, units of pressure, and other parameters, any computer having a serial port and terminal emulation software can be connected to the PPT. Analog output from the 12-bit digital-to-analog converter may be obtained without a host computer. User-selected functions may be set through the digital interface, and these may either be used temporarily (until the PPT is powered down) or be stored in the internal EEPROM to automatically configure the PPT each time power is applied. The TDM uses the multidrop RS-485 bus option of the Honeywell PPTR0300AP5VB to communicate with the laptop. Current laptops have RS-232 and USB connectivity, which requires that an RS-485 to RS-232 converter be placed in line between the transducers and laptops. Future developments of software and sensor interface may move to USB connectivity. A submersible waterproof 6-pin male connector, built by SUBCONN, is molded onto the DWDS. SUBCONN submersible MCIL6F and MCIL6M connectors are used to attach the depth sensor to the cable.

Output: RS-232 digital with 0–5 V analog or RS-485 digital with 0–5 V analog

Power Requirements: Supply voltage, 6 to 30 VDC

Operating Current: 19–27 mA

Baud Rates: 1200, 2400, 4800, 9600, 14400, 19200, 28800

Bus Addressing: Up to 89 units

Overpressure: 3x FS; maximum, 6000 psi

Burst Pressure: 3x FS; maximum, 8500 psi

Mechanical Shock: 1500 g, 0.5 msec half sine

Temp Shock: 24 one-hour cycles, -40 to 85 °C

Vibration: 0.5 in or 20 g, 20 Hz–2 kHz

Manufacturer/Model: Honeywell, Model PPTR0300AP5VB

12001 Highway 55, Plymouth, MN 55441, Tel: 800-323-8295

www.honeywell.com/pressuresensing

Field/Sensor Verification System: A Pelican Case, Inc., Model 1520 protective instrument case was chosen to house the SVS. Designed and built at NEDU, the SVS has an aluminum plate that fits inside the top portion of the Pelican case, a plate to which all the pressure control valves, regulators, pressure ports, and gauges are

mounted. The SVS's design is simple: An alternate pressure source provides gas pressure to a control regulator, which can be adjusted to various set points (depth) to verify that the DWDS is working correctly. This verification is accomplished by cross checking DWDS readings one-to-one against those of an instrument gauge.

DISCUSSION AND RECOMMENDATIONS

Laptop Computer: The laptop/portable computer selected should have support equipment that includes having a touch screen capability, a primary battery, a secondary battery, a DVD/CDRW drive, external battery chargers, auto/air adapters, power cords (AC adapters), and standard operating system software packages. Additional features of the laptop should include rugged design and an ability to operate in extreme outdoor conditions for extended periods of time — up to eight hours on its own battery power. The laptop viewing screen should be able to provide a clear image in all light conditions, ranging from bright outside sunlight to dim light and total darkness. Other features of the laptop should include Ethernet access as well as USB and serial port connections that can support the digital interface of the pressure transducers. An additional advantage would be a remote operation/viewing capability via a handheld device carried by the dive site supervisor/operator.

Sensor Instrumentation Case: The protective case should be of a make and design to safely house the TDM support instrumentation. It should be so constructed that it can travel or be shipped unrestricted on common carrier aircraft or other common carrier means. Since the SIC will be used on the dive site and on locations where it will be directly exposed to extreme weather conditions, any modifications made to it should not compromise its overall waterproof/weatherproof integrity. It may be advisable for the case to be buoyant, if it is dropped into the water. Its overall size and weight for travel must be considered for users-operators intending to take it from their duty stations to dive locations. Depending on future designs, changes in operational requirements, and developments in instrumentation or mission roles, the SIC could be reduced in size and weight. As a forethought, the next-generation design could combine diver communication, camera control, audio and video recording, lights, and the DWDS all into one system — a combination making it a complete TDM.

Battery: The two 12 VDC-12 AH/20 HR batteries were wired in parallel to provide the TDM with an extended runtime of approximately eight hours. These two batteries have a combined weight of approximately 17 lb and, when added to the other components, bring the total weight of the SIC close to 44 lb. It is recommended that any battery used be a sealed/AGM battery. The battery should not be restricted for passenger or cargo aircraft and should be able to meet air transportation requirements specified in DOT 49 CFR173.159, IATA (International Air Transport Association) and ICAO (International Civil Aviation Organization).

Another consideration is not to have the battery housed within the SIC. Instead, some alternate VDC power or deep cycle batteries that have a couple hundred ampere hours of stored energy could be procured upon arrival at the dive site. The DWDS can

operate on voltages from 6 to 30 VDC, levels which allow for a wide range of possible power sources. If the power source is not placed inside the DIC, such a change would greatly modify other factors: e.g., battery charging or an additional power supply would not be needed, and thus the size and weight of the SIC could be reduced.

The basic instrumentation needed for the DWDS is an isolated RS485 converter that can provide the serial/digital connection (RS232/USB) for transferring information into the laptop. The isolated converters can be port powered from the laptop, and basic power from a VDC source would power the DWDS. This modification would also reduce the SIC's size and weight and thereby result in a smaller version of the TDM. Some means for supplying the TDM with additional battery power (yet with no interference or interruption) should be possible during its operation.

Power Supply and Battery Charging: The TDM's power supplies should be able to operate from universal VAC power, to recharge the batteries housed inside the SIC, and to provide additional VDC power as needed. Yet having VAC power readily available around a dive site can be a challenge — and a problem in minimizing electrical shock hazard. A need for not having on-board batteries housed within the SIC may develop, however, and local battery power could be provided at the dive site. Such a need to dispense with on-board, SIC-housed batteries would enable the VAC to be removed, and the power supplies used for battery charging to be replaced with a DC/DC converter. The DC/DC converter is self-powered from the input VDC source, can be sized to accept a wide range of input supply VDC, and can convert that power to the required level needed to operate the DWDS (6 to 30 VDC) or any other device currently located within the SIC.

Connectors: Connectors that will not allow cross connection of sources but will allow three contacts for AC power, two contacts for DC power, and six contacts for data should be selected. All connectors should be made of a material or in a design to be used in an environment subject to extreme corrosion and, when mated, they should be able to meet IP67 or IP68 standards. The connector should have a compact design. It should also have sealing caps available that can maintain the IP rating for unmated connectors. Each connector should have positive locating keyways to prevent misconnections, and it should be made for easy assembly.

Only submersible connectors should be used for attaching the depth sensor to the cable. Connectors must have a locking ring or device that will not allow the connections to be broken while in use.

Diver Instrumentation Cable: Special consideration should be given to the DIC specifications and design. Since the DIC will be used in very adverse diving environments, it should be kept to a suitable size and make so that it can be easily assembled into a diving umbilical without adding excessive weight or drag to the umbilical. The DIC's electrical conductive elements should be made for digital process signals. It may become advantageous to incorporate all diver information into one cable for communication, audio and video functions, lights, and the TDM.

Currently, the DICs are being used successfully in the field. Early problems with the DICs were related to improper handling of the connectors or cables and improperly protecting the cables from the sharp metal hazards common in diving. These earlier problems have been addressed and resolved.

Diver-worn Depth Sensor: The Honeywell model PPT PPTR0300AP5VB, the current DWDS, serves as a referent for comparison with any future sensor that may be considered for the TDM. The DWDS should be a simple-to-operate device requiring low VDC power (6 to 30 VDC) for transmitting digital sensor information. Current use of the DWDS shows the sound capabilities of the digital–serial sensor interface to the TDM, and future designs may include additional modem possibilities such as serial to USB, serial to Ethernet, and serial to telemetry.

Field/Sensor Verification System: The SVS is well received in the field. Used to verify the DWDS, it also provides a means to verify other dive-related procedures such as diver emergency gas setup (EGS).

CONCLUSION

The TDM has many possibilities, and this first prototype design offers a starting point for future TDM development. The end product — its function, the support that it will provide to the dive operation, and all aspects of the system — should be kept in mind. A future TDM that can collect and possibly distribute, not just dive depth and time but also data on the entire dive could be on site at each dive location in the near future.

APPENDIX — TDM Pictures and Diagrams

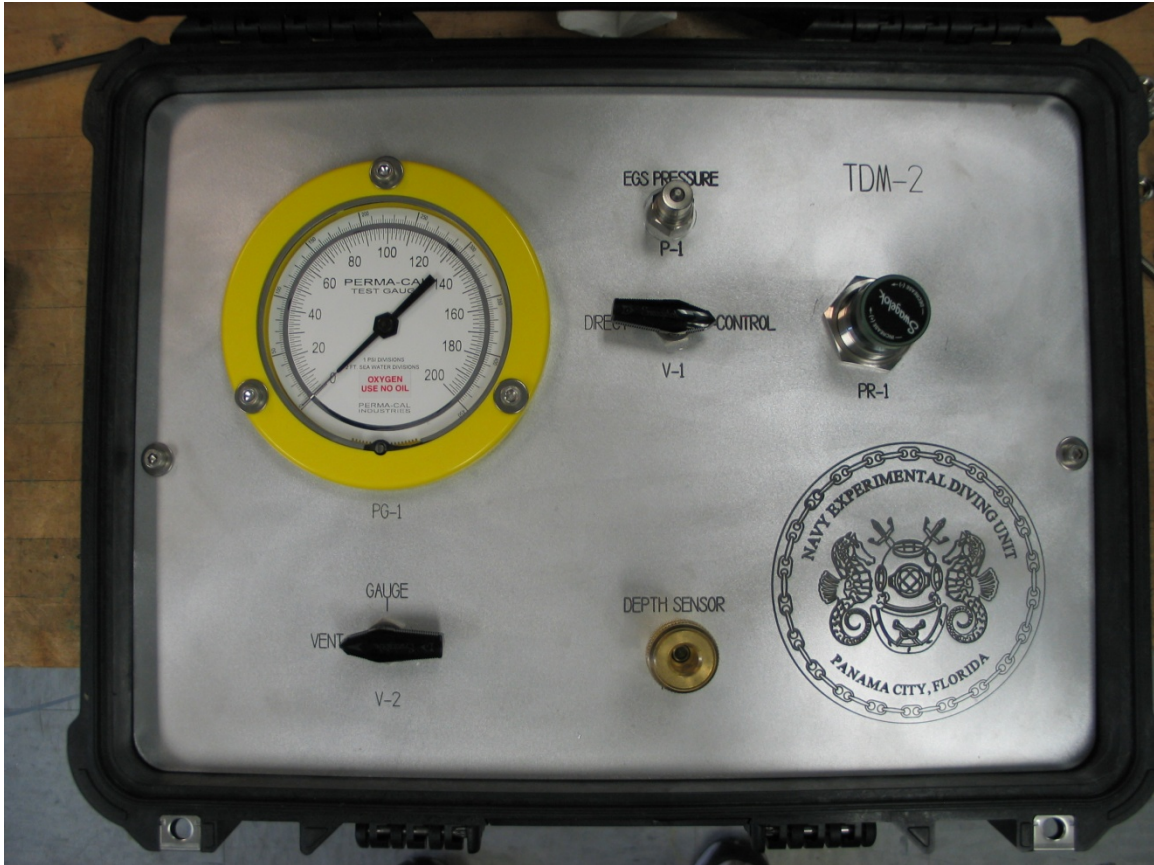

Field/Sensor Verification System (SVS) front panel. The SVS provides a pressure/depth comparison gauge (PG-1), pressure regulation (PR-1) for set point control and connection ports (P-1), and a depth sensor.

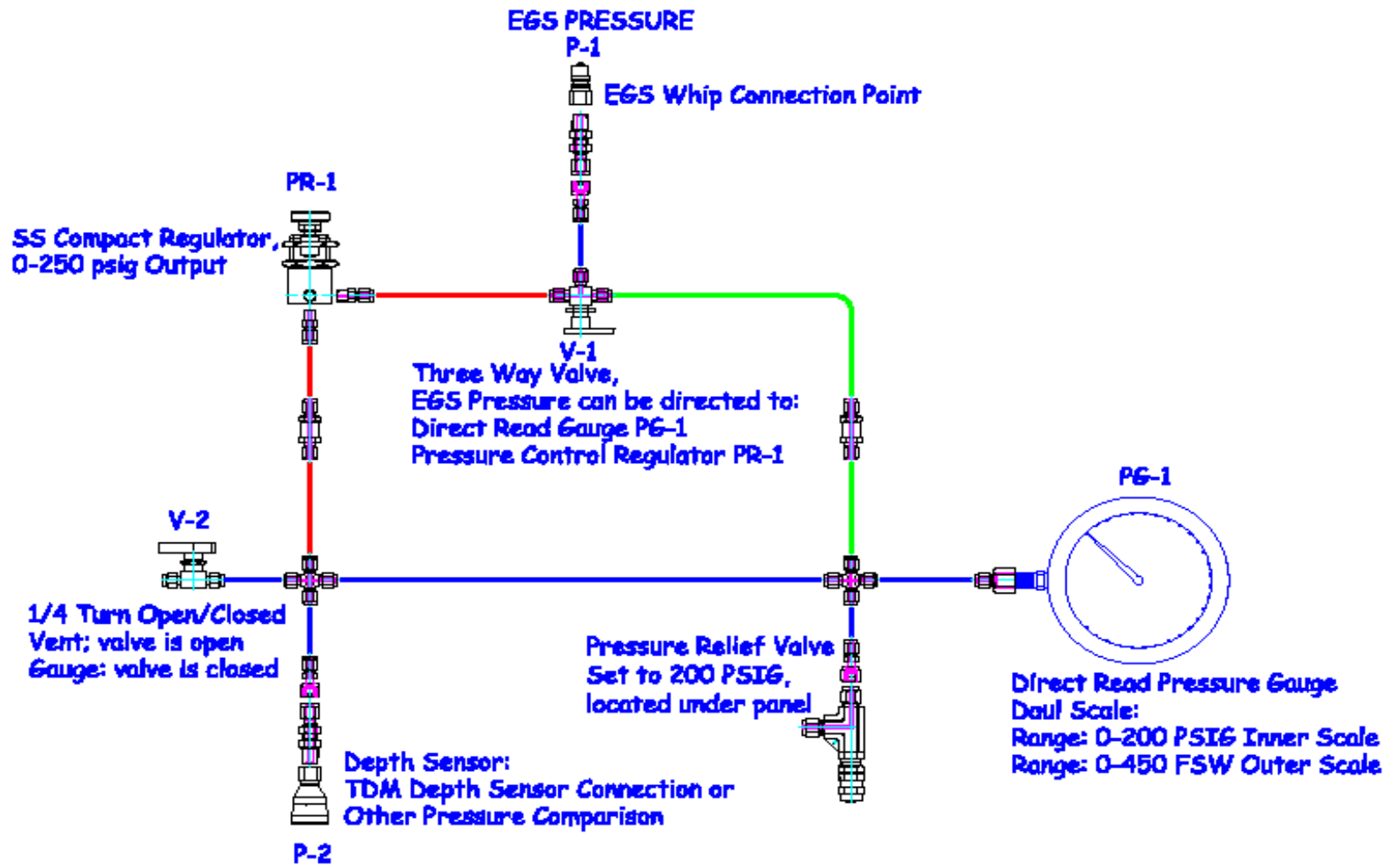

Field/Sensor Verification System (SVS) layout of components and functions.

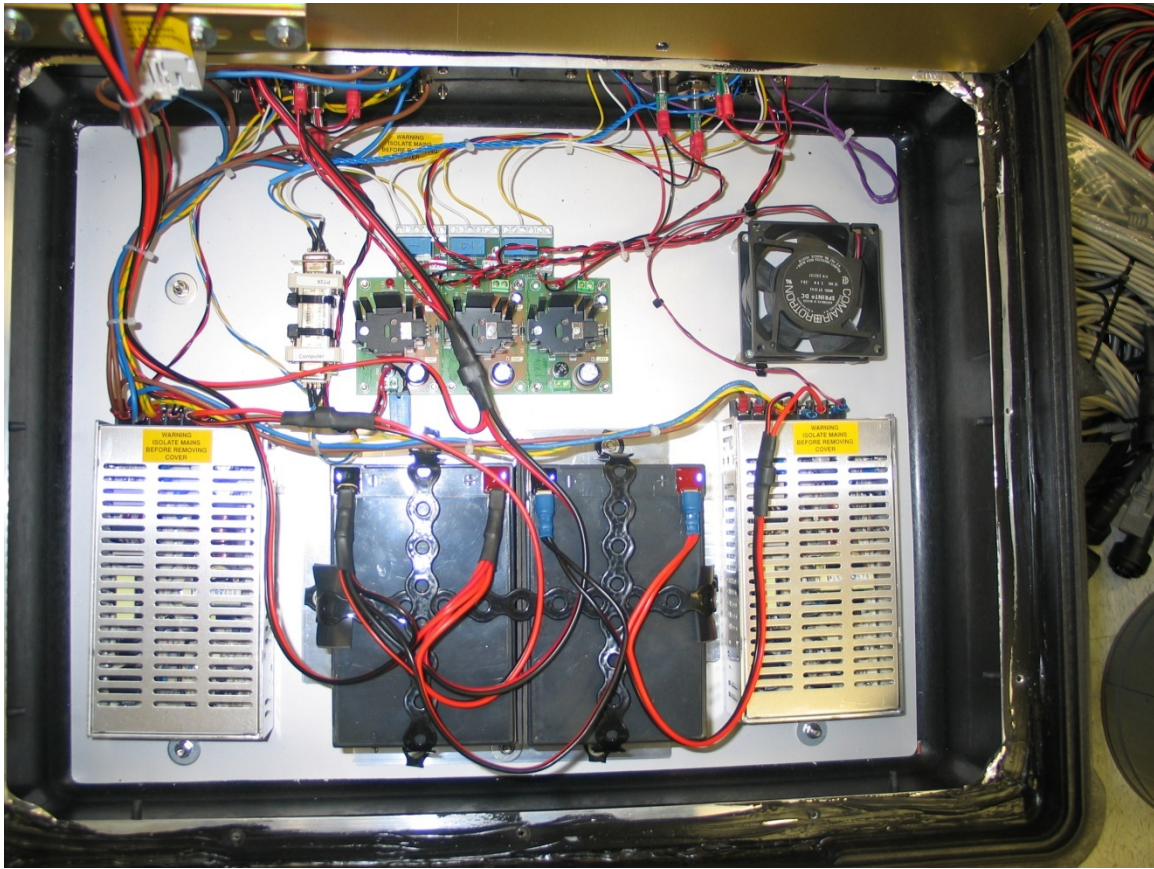

Instrumentation layout of SIC : batteries, power supplies, PCBs, and cooling fan inside the SIC.

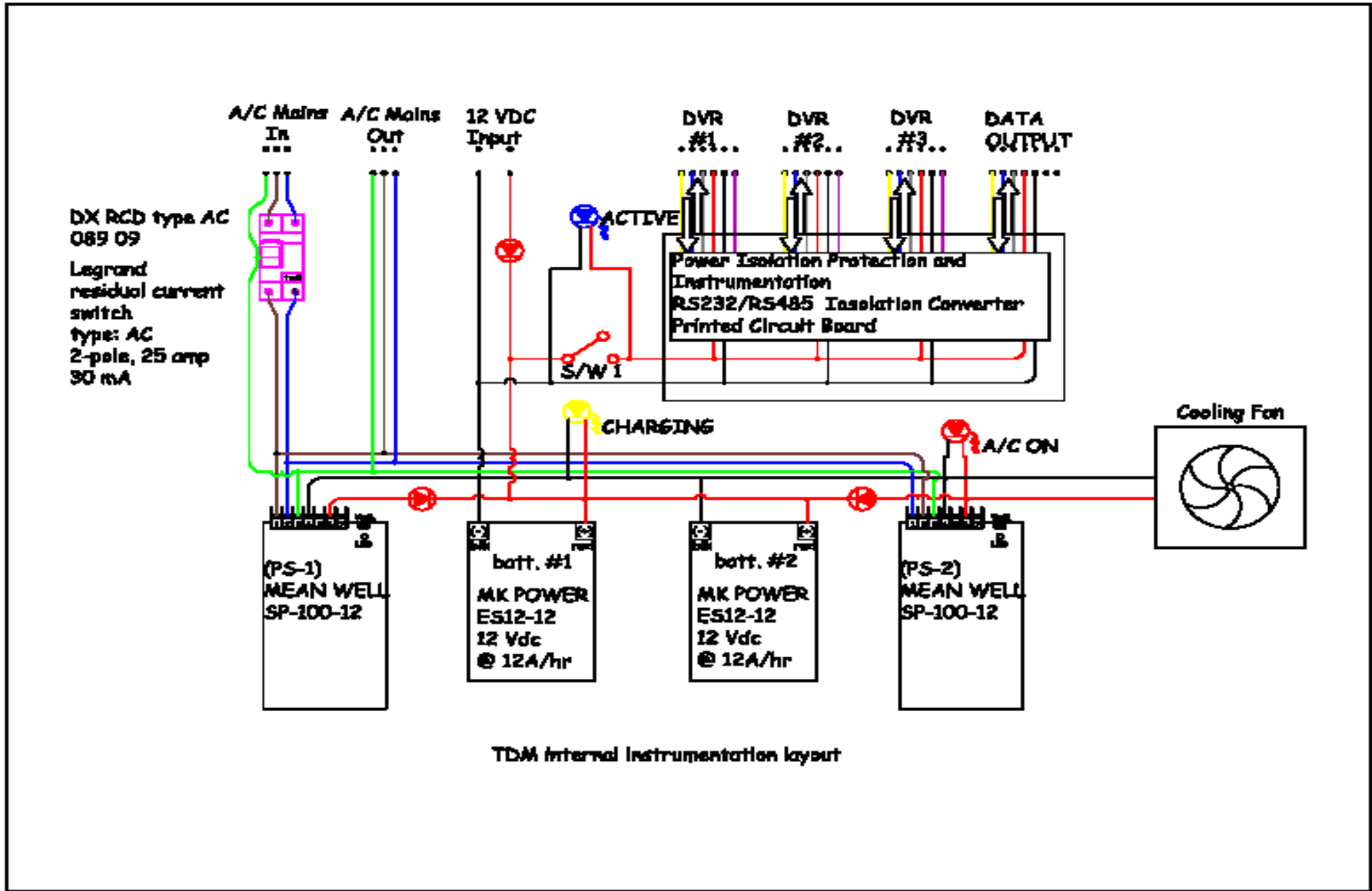
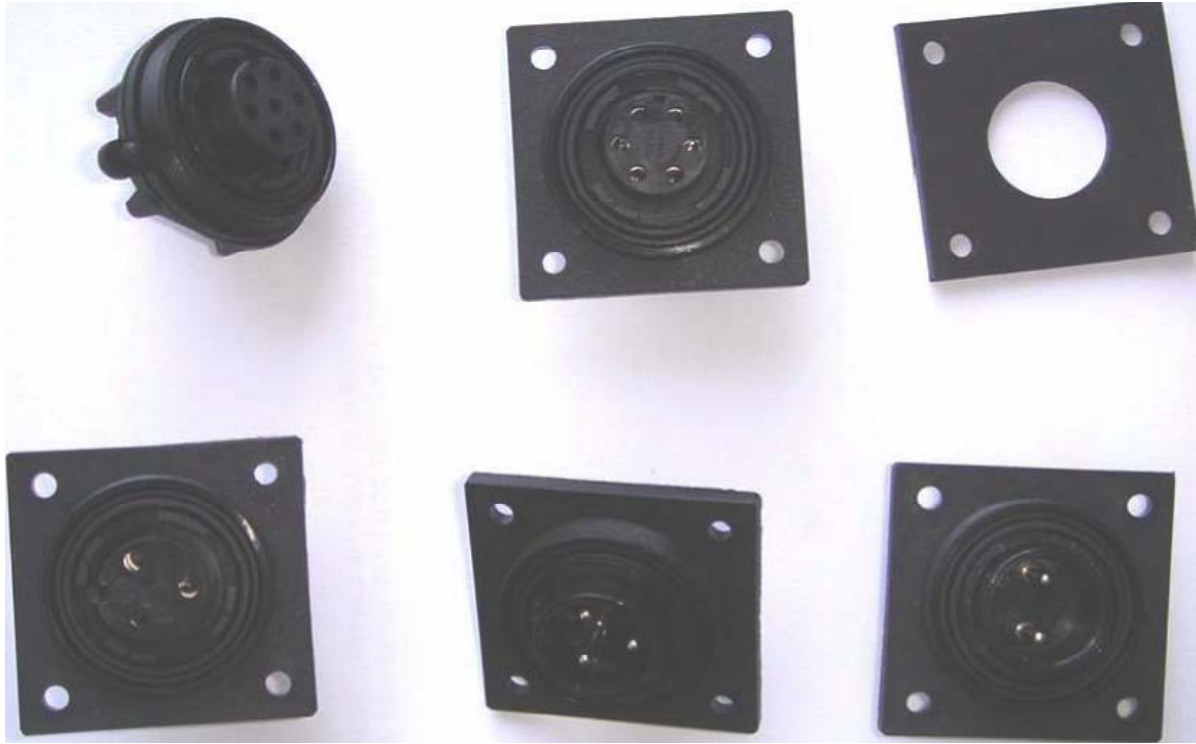
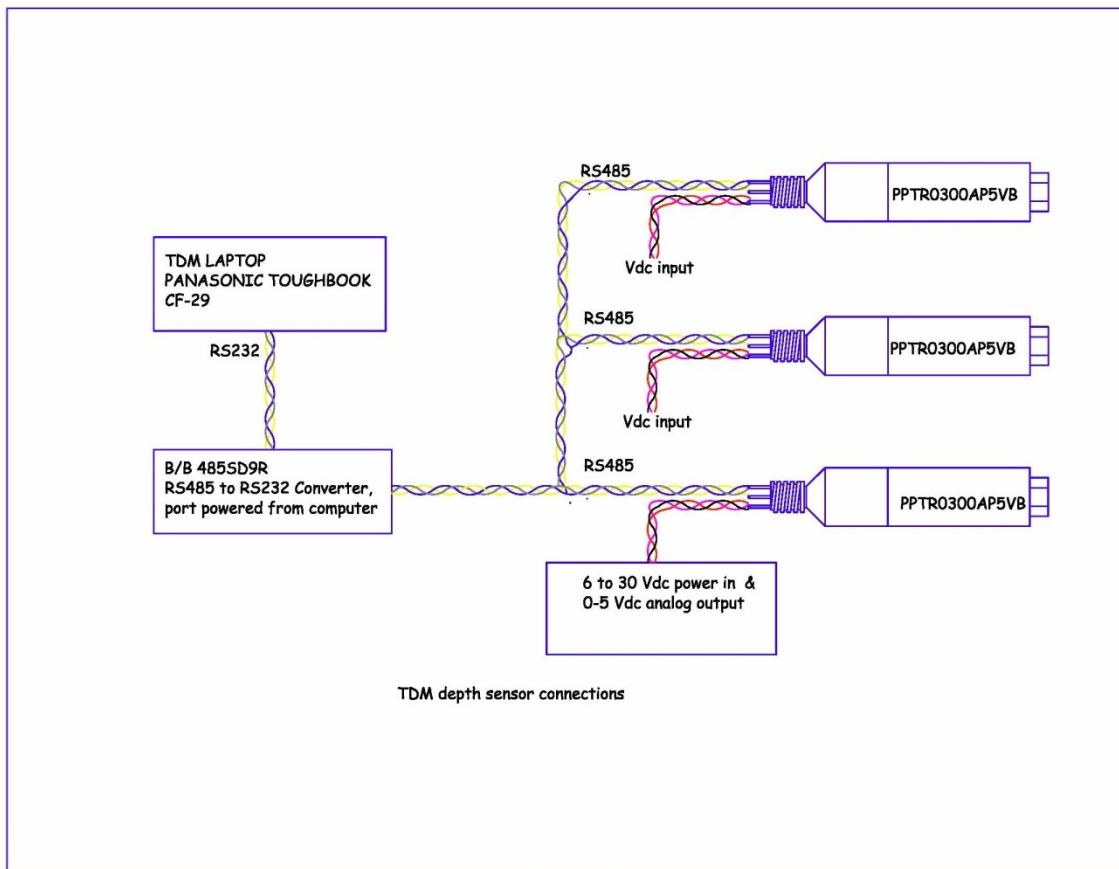

Diagram of SIC wiring.



BULGIN Circular Connector, Buccaneer Series, IP68-rated. Various connectors were selected that would not allow cross connection of sources, three contacts for AC power, two contacts for DC power, six contacts for data, and so forth.





PPTR depth sensor wiring pin out.

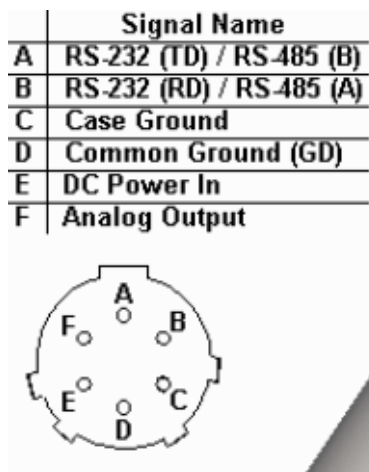



Diver-worn Depth Sensor (DWDS) — the Honeywell Model PPTR0300AP5VB Precision Pressure Transducer (PPT) — selected for the DWDS. These pressure sensors are shown with molded submersible waterproof 6-pin male connectors and ¼" NPT pressure ports. SUBCONN submersible MCIL6F and MCIL6M connectors are used to attach the depth sensor to the cable.

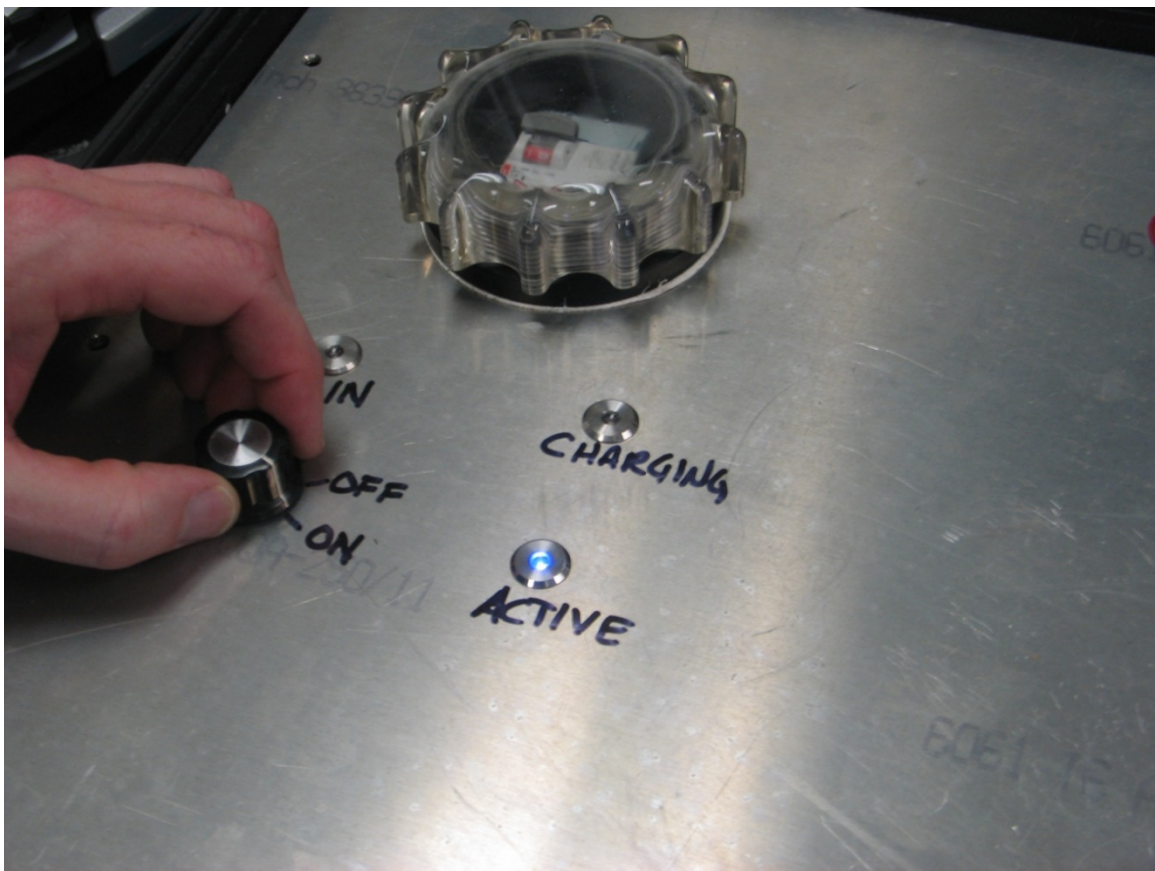

SIC view of top plate, showing switch operation and LED.



SIC and 350 ft DIC with DWDS attached.