

REPORT DOCUMENTATION PAGE			Form Approved OMB NO. 0704-0188		
<p>The public reporting burden for this collection of information is estimated to average 1 hour per response, including the time for reviewing instructions, searching existing data sources, gathering and maintaining the data needed, and completing and reviewing the collection of information. Send comments regarding this burden estimate or any other aspect of this collection of information, including suggestions for reducing this burden, to Washington Headquarters Services, Directorate for Information Operations and Reports, 1215 Jefferson Davis Highway, Suite 1204, Arlington VA, 22202-4302. Respondents should be aware that notwithstanding any other provision of law, no person shall be subject to any penalty for failing to comply with a collection of information if it does not display a currently valid OMB control number.</p> <p>PLEASE DO NOT RETURN YOUR FORM TO THE ABOVE ADDRESS.</p>					
1. REPORT DATE (DD-MM-YYYY) 03-01-2012		2. REPORT TYPE Final Report		3. DATES COVERED (From - To) 8-Jun-2011 - 3-Dec-2011	
4. TITLE AND SUBTITLE Phase 1 achievements for developing a technology to manage post-traumatic pain with ultrasound neuromodulation.			5a. CONTRACT NUMBER		
			5b. GRANT NUMBER W911NF-11-C-0204		
			5c. PROGRAM ELEMENT NUMBER 665502		
6. AUTHORS Sumon K. Pal			5d. PROJECT NUMBER		
			5e. TASK NUMBER		
			5f. WORK UNIT NUMBER		
7. PERFORMING ORGANIZATION NAMES AND ADDRESSES Synsonix, LLC 610 E. Gilbert Dr. Apt 235 Tempe, AZ 85281 -2039			8. PERFORMING ORGANIZATION REPORT NUMBER		
9. SPONSORING/MONITORING AGENCY NAME(S) AND ADDRESS(ES) U.S. Army Research Office P.O. Box 12211 Research Triangle Park, NC 27709-2211			10. SPONSOR/MONITOR'S ACRONYM(S) ARO		
			11. SPONSOR/MONITOR'S REPORT NUMBER(S) 59952-LS-SB1.1		
12. DISTRIBUTION AVAILABILITY STATEMENT Approved for Public Release; Distribution Unlimited					
13. SUPPLEMENTARY NOTES The views, opinions and/or findings contained in this report are those of the author(s) and should not be construed as an official Department of the Army position, policy or decision, unless so designated by other documentation.					
14. ABSTRACT The objective of this effort is to demonstrate the feasibility of using ultrasound induced neuromodulation to manage pain. SynSonix, LLC has been developing ultrasound neuromodulation (UNMOD) to noninvasively stimulate neural circuitry. Pain management for acute traumas is generally accomplished with narcotics, which is less than ideal in a battlefield scenario as they severely effect cognitive abilities and have other unwanted side effects such as respiratory depression. Our technology of peripheral ultrasound neuromodulation (PUNMOD) offers several					
15. SUBJECT TERMS Ultrasound neuromodulation, pain management, UNMOD					
16. SECURITY CLASSIFICATION OF:			17. LIMITATION OF ABSTRACT UU	15. NUMBER OF PAGES	19a. NAME OF RESPONSIBLE PERSON Sumon Pal
a. REPORT UU	b. ABSTRACT UU	c. THIS PAGE UU			19b. TELEPHONE NUMBER 412-414-0187

## Report Title

Phase 1 achievements for developing a technology to manage post-traumatic pain with ultrasound neuromodulation.

### ABSTRACT

The objective of this effort is to demonstrate the feasibility of using ultrasound induced neuromodulation to manage pain. SynSonix, LLC has been developing ultrasound neuromodulation (UNMOD) to noninvasively stimulate neural circuitry. Pain management for acute traumas is generally accomplished with narcotics, which is less than ideal in a battlefield scenario as they severely effect cognitive abilities and have other unwanted side effects such as respiratory depression. Our technology of peripheral ultrasound neuromodulation (PUNMOD) offers several advantages over narcotics and current methods of neurostimulation. PUNMOD has the potential to be highly portable as a battlefield analgesic and has the advantage of leaving the patients cognitive abilities intact. In addition PUNMOD does not carry with it the risk of abuse or the need for the surveillance that is associated with pharmaceutical analgesics.

---

**Enter List of papers submitted or published that acknowledge ARO support from the start of the project to the date of this printing. List the papers, including journal references, in the following categories:**

**(a) Papers published in peer-reviewed journals (N/A for none)**

Received                  Paper

**TOTAL:**

**Number of Papers published in peer-reviewed journals:**

---

**(b) Papers published in non-peer-reviewed journals (N/A for none)**

Received                  Paper

**TOTAL:**

**Number of Papers published in non peer-reviewed journals:**

---

**(c) Presentations**

**Number of Presentations:**      0.00

---

**Non Peer-Reviewed Conference Proceeding publications (other than abstracts):**

Received                  Paper

**TOTAL:**

**Number of Non Peer-Reviewed Conference Proceeding publications (other than abstracts):**

---

**Peer-Reviewed Conference Proceeding publications (other than abstracts):**

Received                  Paper

**TOTAL:**

Number of Peer-Reviewed Conference Proceeding publications (other than abstracts):

---

**(d) Manuscripts**

Received                  Paper

**TOTAL:**

**Number of Manuscripts:**

---

**Books**

Received                  Paper

**TOTAL:**

**Patents Submitted**

---

**Patents Awarded**

---

**Awards**

---

---

**Graduate Students**

<u>NAME</u>	<u>PERCENT SUPPORTED</u>
<b>FTE Equivalent:</b>	
<b>Total Number:</b>	

---

**Names of Post Doctorates**

<u>NAME</u>	<u>PERCENT SUPPORTED</u>
<b>FTE Equivalent:</b>	
<b>Total Number:</b>	

---

**Names of Faculty Supported**

<u>NAME</u>	<u>PERCENT SUPPORTED</u>
<b>FTE Equivalent:</b>	
<b>Total Number:</b>	

---

**Names of Under Graduate students supported**

<u>NAME</u>	<u>PERCENT SUPPORTED</u>
<b>FTE Equivalent:</b>	
<b>Total Number:</b>	

**Student Metrics**

This section only applies to graduating undergraduates supported by this agreement in this reporting period

The number of undergraduates funded by this agreement who graduated during this period: .....	0.00
The number of undergraduates funded by this agreement who graduated during this period with a degree in science, mathematics, engineering, or technology fields:.....	0.00
The number of undergraduates funded by your agreement who graduated during this period and will continue to pursue a graduate or Ph.D. degree in science, mathematics, engineering, or technology fields:.....	0.00
Number of graduating undergraduates who achieved a 3.5 GPA to 4.0 (4.0 max scale):.....	0.00
Number of graduating undergraduates funded by a DoD funded Center of Excellence grant for Education, Research and Engineering:.....	0.00
The number of undergraduates funded by your agreement who graduated during this period and intend to work for the Department of Defense .....	0.00
The number of undergraduates funded by your agreement who graduated during this period and will receive scholarships or fellowships for further studies in science, mathematics, engineering or technology fields: .....	0.00

**Names of Personnel receiving masters degrees**

<u>NAME</u>
<b>Total Number:</b>

**Names of personnel receiving PHDs**

<u>NAME</u>
<b>Total Number:</b>

**Names of other research staff**

<u>NAME</u>	<u>PERCENT SUPPORTED</u>
Sumon K Pal	1.00
<b>FTE Equivalent:</b>	<b>1.00</b>
<b>Total Number:</b>	<b>1</b>

**Sub Contractors (DD882)**

## **Inventions (DD882)**

### **Scientific Progress**

See attachment below.

### **Technology Transfer**

**FINAL PROGRESS REPORT**

**SynSonix, LLC**

**Contract No:** W911NF-11-C-0204

**Proposal Title:** Ultrasound for Neuromodulation and Control of Post-Trauma Pain

**Proposal No:** ARO #59952-LS-SB1

**PI:** Sumon K. Pal, PhD

## **1. Objective**

The objective of this effort is to demonstrate the feasibility of using ultrasound induced neuromodulation to manage pain. SynSonix, LLC has been developing ultrasound neuromodulation (UNMOD) to noninvasively stimulate neural circuitry. Pain management for acute traumas is generally accomplished with narcotics, which is less than ideal in a battlefield scenario as they severely effect cognitive abilities and have other unwanted side effects such as respiratory depression. Our technology of peripheral ultrasound neuromodulation (PUNMOD) offers several advantages over narcotics and current methods of neurostimulation. PUNMOD has the potential to be highly portable as a battlefield analgesic and has the advantage of leaving the patients cognitive abilities intact. In addition PUNMOD does not carry with it the risk of abuse or the need for the surveillance that is associated with pharmaceutical analgesics.

## **2. Phase I Achievements**

### **2.1 Software platform**

The initial goal for our Phase I effort was to develop a modular software package for applying UNMOD. The software package addressed a need for a systematic, combinatorial approach for testing new waveforms in different phantom, animal and human models. We developed a software platform using National Instruments Labview and the PXI control system. The software platform has multiple capabilities:

1. Complex waveform generation and scanning module
2. High speed hydrophone and high-voltage electrical recordings with spectral information
3. Electrophysiology recordings
4. Data analysis with noise reduction

Some examples of the capabilities of the software platform we developed are shown below. In Figure 1 a sinusoidal voltage waveform was generated (green) and the resulting current (magneta) and voltage were recorded using our software platform. The use of waveform generators allows the measurement of the electrical responses of transducers to clean sinusoidal as well as other multi-frequency waveforms. This technique can be applied to any transducer and used to measure the impedance and total electrical power through the system. Figure 2 demonstrates how we can use our software for the measurement of electrical signals from waveform generators, transducers and hydrophones. Spectral analysis can also be performed to see how these signals undergo transformations through each stage. This can be used for the characterization of waveform generators, amplifiers, and transducers. Each component can be interchanged and recorded under the same conditions and thus provide a comparison method for their quality. Figure 3 demonstrates the ability to record electrophysiology data using our software. In this case neurons from an animal model were recorded while scanning for more effective waveforms. The recordings provide real-time feedback for the effectiveness of a waveform. Figure 4 shows how the software can perform various functions including Fourier transforms as well as significant electrical noise reduction. In this trial, raw neurophysiology data from an animal model was recorded with electrical shielding and grounding removed. The middle panel shows a close-up of the original trace (green) and a filtered trace (red). The close-up shows many dips (neural firing) in the red trace that indeed occur in the green trace but cannot be detected through thresholding. The bottom trace is the same filtered trace with many action potentials that can now be detected, allowing for improved data analysis efficiency. Similar techniques can be applied for microneurography and EEG as well as raw MR data for removal of noise and artifacts.

In order to produce the optimal sets of parameters for pain modulation using US stimulation the appropriate US pulse duration (PD), acoustic frequency of the US waveforms (Af), and the pulse repetition frequency (PRF) of the pulses must be discovered. We have developed a program that can generate complex waveforms while being able to record important experimental data such as acoustic intensity, temperature changes, and neural activation levels. Thus in our Phase I effort we have developed an essential tool to discover and characterize waveforms that are optimal for modulating somatosensory inputs.



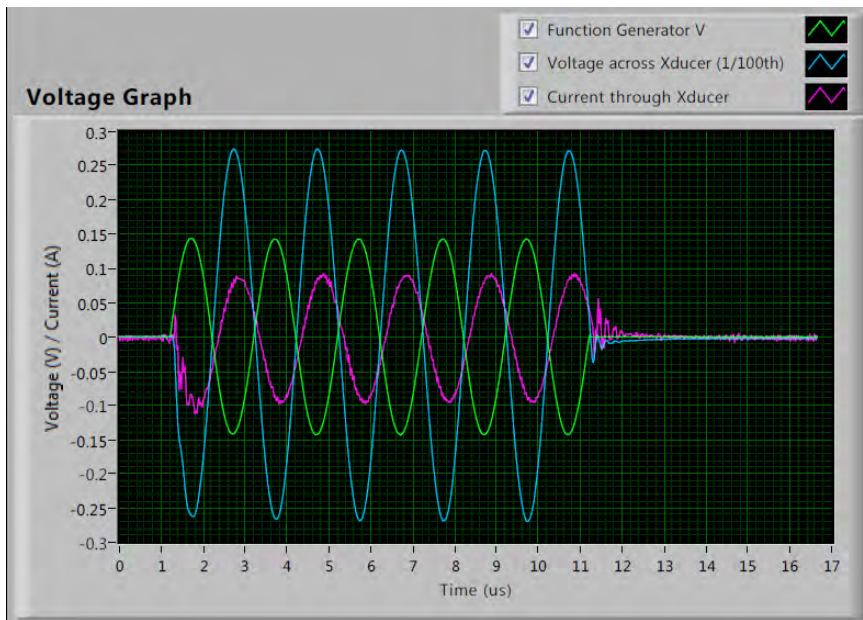

**Figure 1. A sinusoidal voltage waveform (green) was generated using a NI PXI-5421 arbitrary waveform generator and amplified using an RF amplifier (E&I 240L). The resulting voltage (cyan) and current (magenta) through the transducer were recorded using a 100x attenuation oscilloscope probe.**

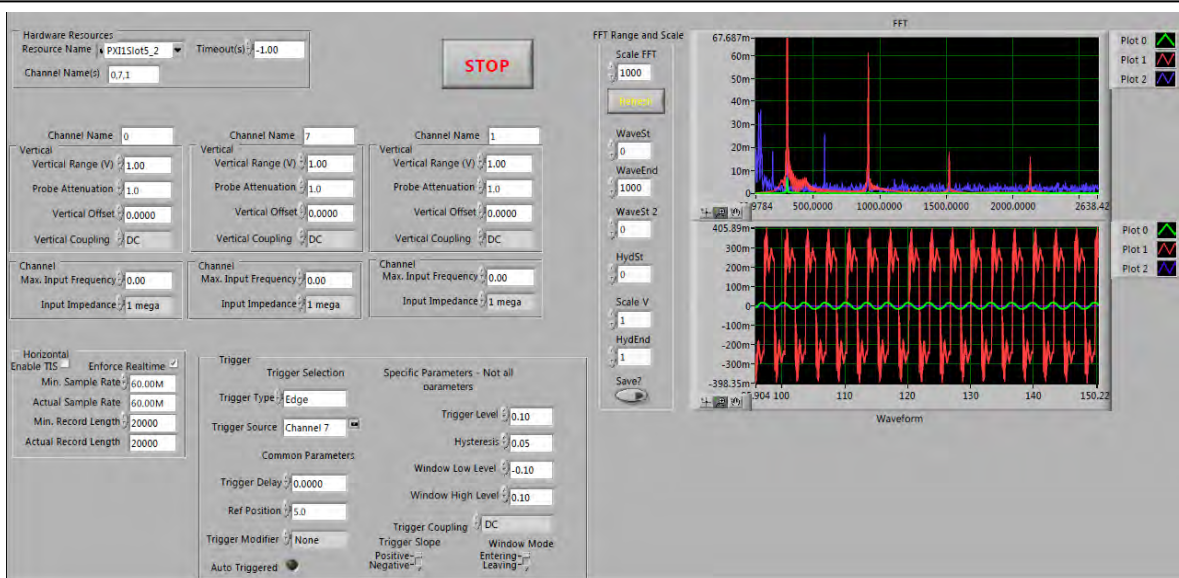

**Figure 2. Software being used for the measurement of electrical signals from waveform generators, voltage and current through transducers, and hydrophone signals.**



**Figure 3. Software used for the integration of UNMOD with analog measurements.**

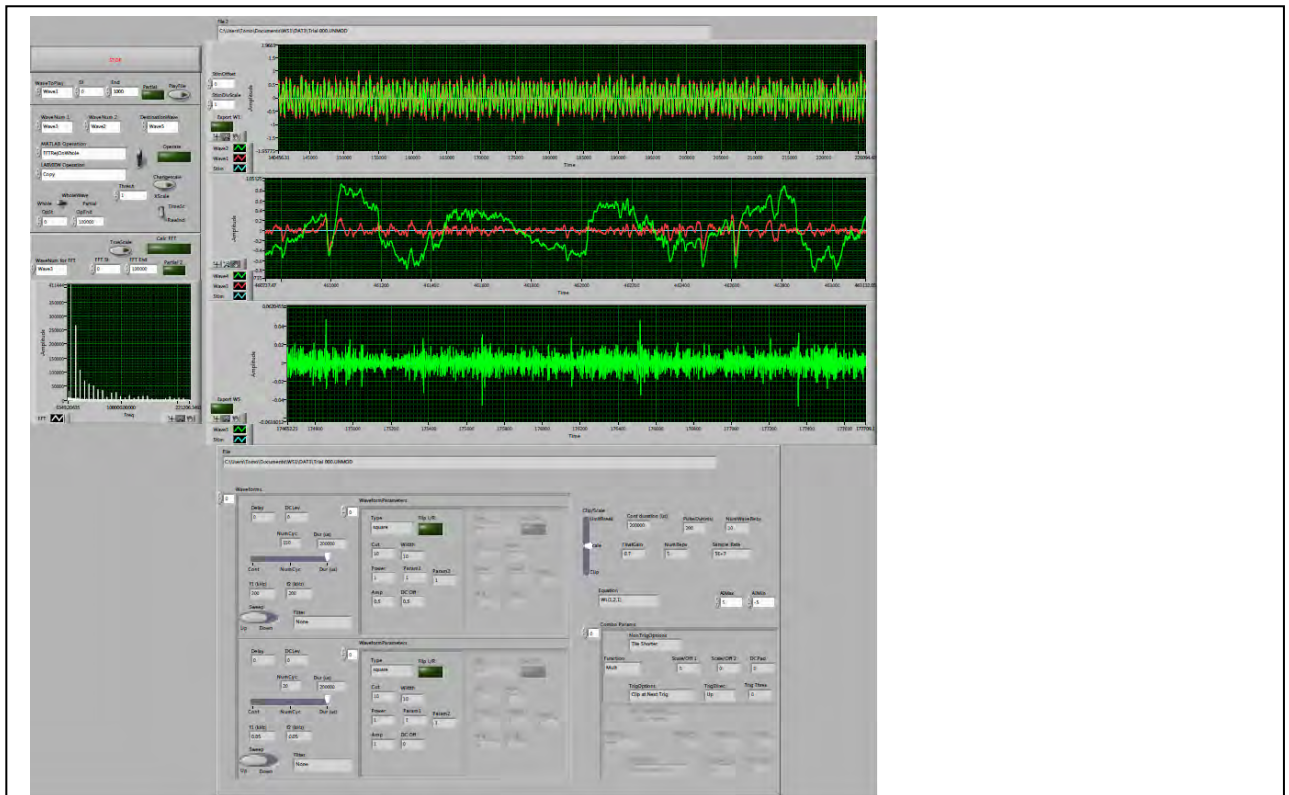
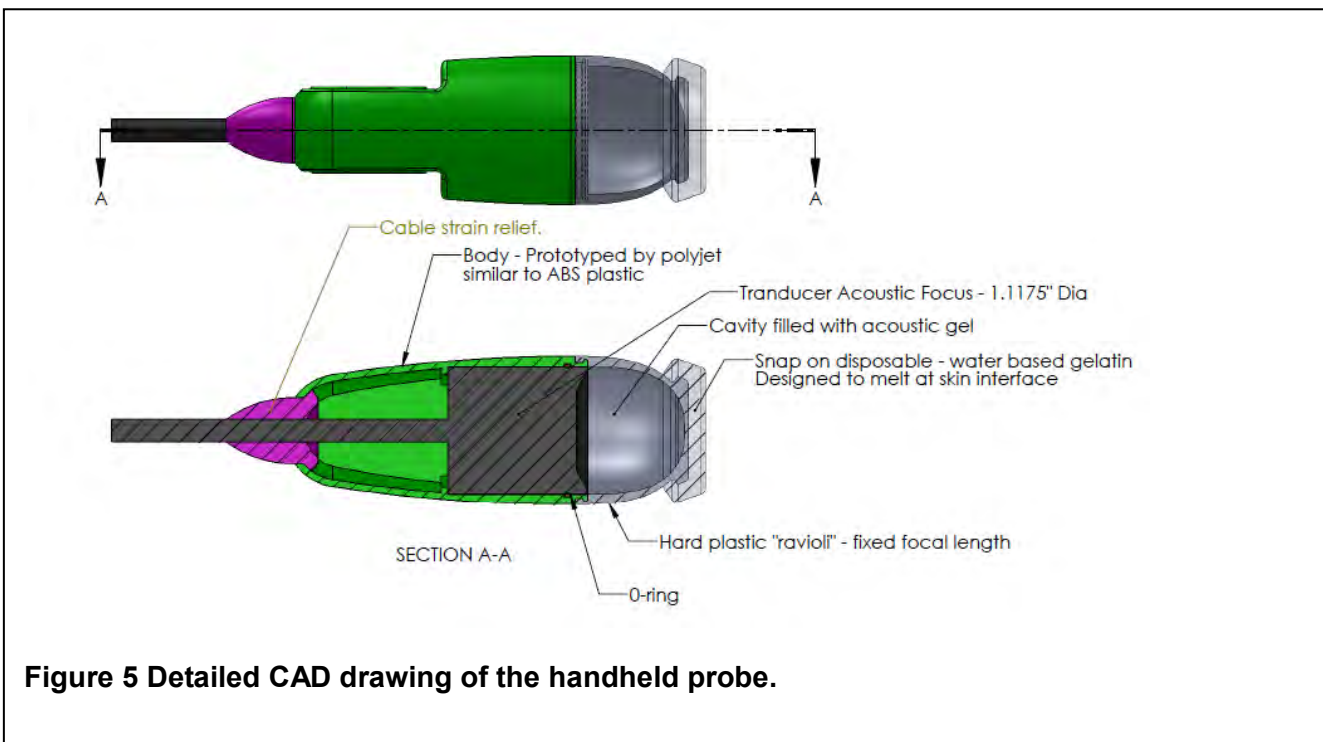

**Figure 4. Software used for the analysis of electrophysiological and general analog data. The software can perform various functions including Fourier transforms (middle left) as well as significant electrical noise reduction. In this trial, raw data (green, top panel) was recorded with electrical shielding and grounding removed. The middle panel shows a close-up of the original trace (green) and a filtered trace (red).**

## 2.2 Completion of alpha prototype:

The overall goal for our Phase I effort was to develop an alpha-prototype for modulating pain circuits with UNMOD. We designed the prototype with several criteria in mind. The prototype should be able to deliver sufficient acoustic intensity to modulate peripheral somatosensory nerves based on our previous studies. The user should be able to change key parameters relevant to the treatment: ultrasound Frequency, pulse repetition frequency, pulse length/duration and stimulus length using uncomplicated controls. The overall system should not weigh more than ten pounds and the US stimulation should be delivered with a handheld probe.

We decided that for our alpha prototype it was important to develop an evaluation system that makes it easy to test in a broad range of contexts. To address this we decided that a hand-held probe would be the best approach. In order for the transducer to couple with skin we decided that at the tip of the transducer housing we would use a flexible “ravioli” interface containing acoustic gel (Fig 5).



For the electronics housing we based our design on wanting to adjust 4 parameters (Ultrasound Frequency, Pulse Repetition Frequency, Pulse length/duration and Stimulus length). For the initial prototype we will have 3 defined points for these parameters. We achieved this by using adjustable potentiometers for each of these parameters. The electronics housing has a simple design with a power cord (we will switch to using a battery in future iterations of the prototype), on/off master power switch, Coax transducer attachment, and a "deliver therapy" button. CAD drawings of several views of the housing is shown below (Fig 6).



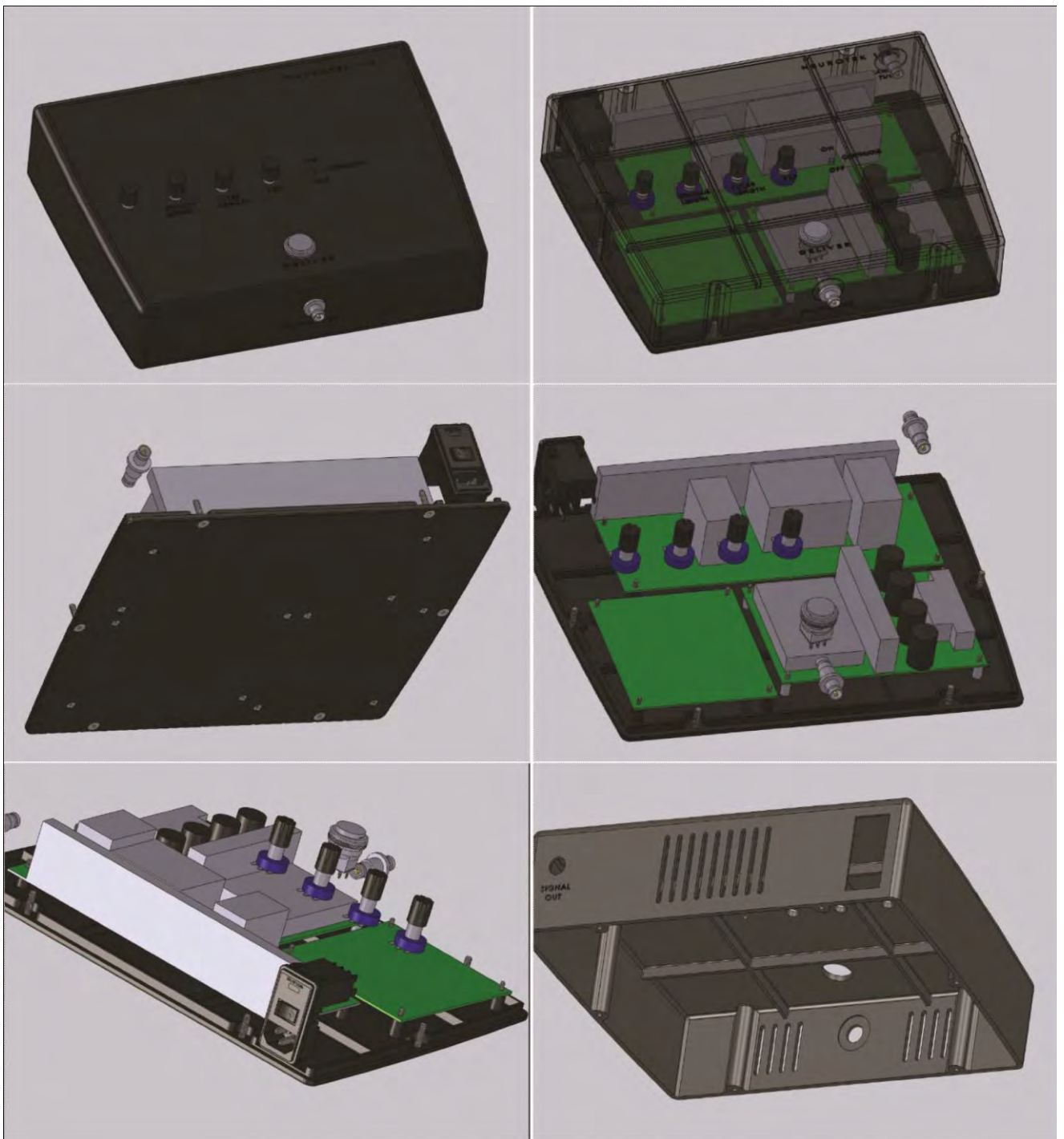
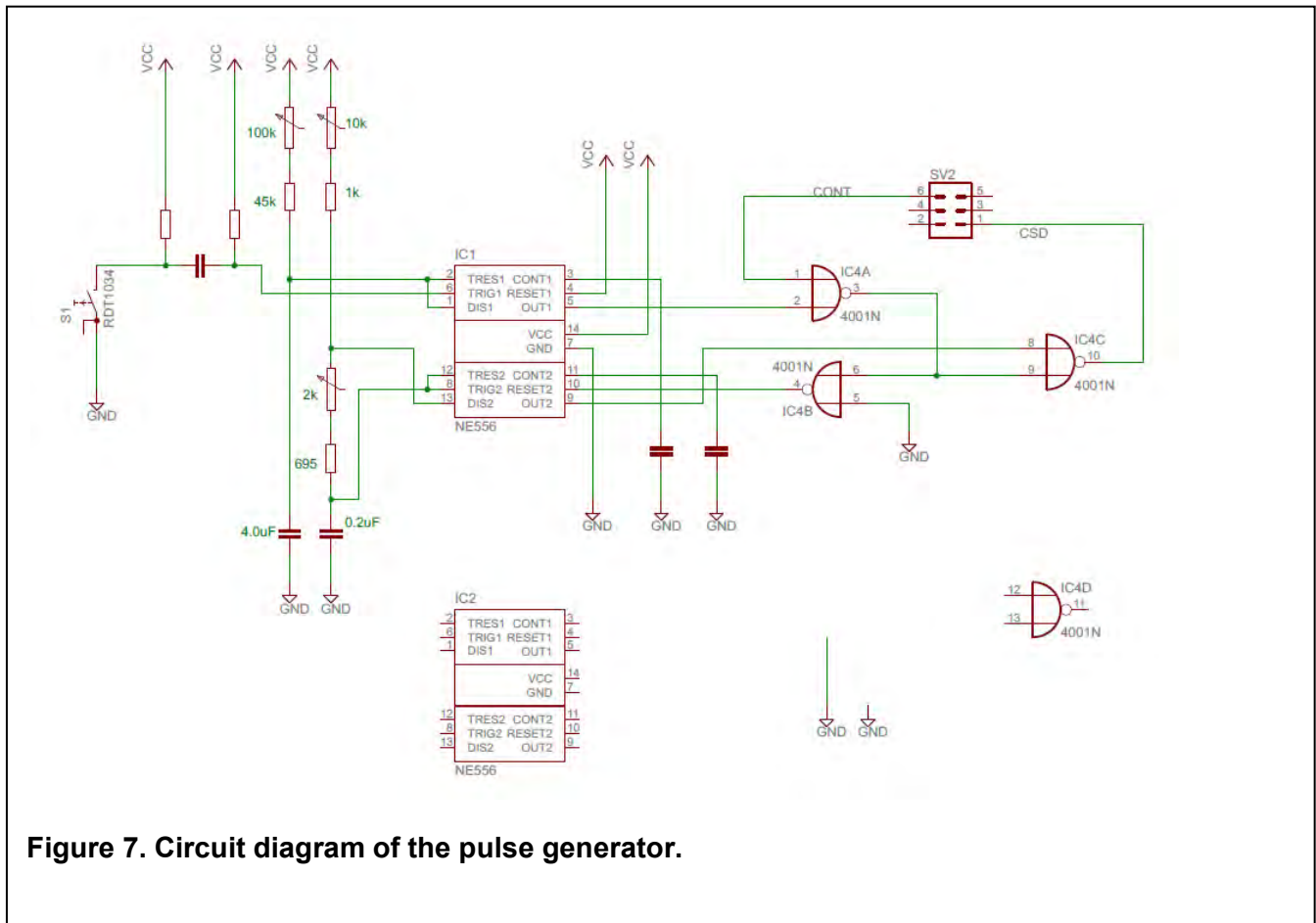

Figure 6. CAD drawings of the electronics housing.

Below is a circuit diagram of the pulse generator (Fig 7). We decided on a system that could produce square wave pulses with a high output power and pulse repetition frequencies in the desired range. Preliminary testing in animal and human models has shown that square waves are capable of modulating neural circuits effectively. In addition square waves are the most electrically efficient which allow for a more light-weight design. Further experiments described in this proposal will be used to determine if more complex waveforms are more effective for pain modulation or are necessary to modulate distinct pain pathways.



**Figure 7. Circuit diagram of the pulse generator.**

Below is a list of some of the features we incorporated into our alpha prototype.

- Potentiometer controlled Pulse Repetition Frequency adjustment
- Potentiometer controlled Pulse Length/Duration
- Potentiometer controlled Stimulus Length
- Spare Potentiometer for future development
- Internal Potentiometer (On PCBA) controls US frequency.
- Toggle switch for "Continuous" mode on/off
- LED lighted Momentary "Deliver" button
- BNC transducer connector
- BNC signal out connector on rear panel
- Fused power input with on/off switch

Below is a picture of the alpha-prototype (Neurotrek V1.0).

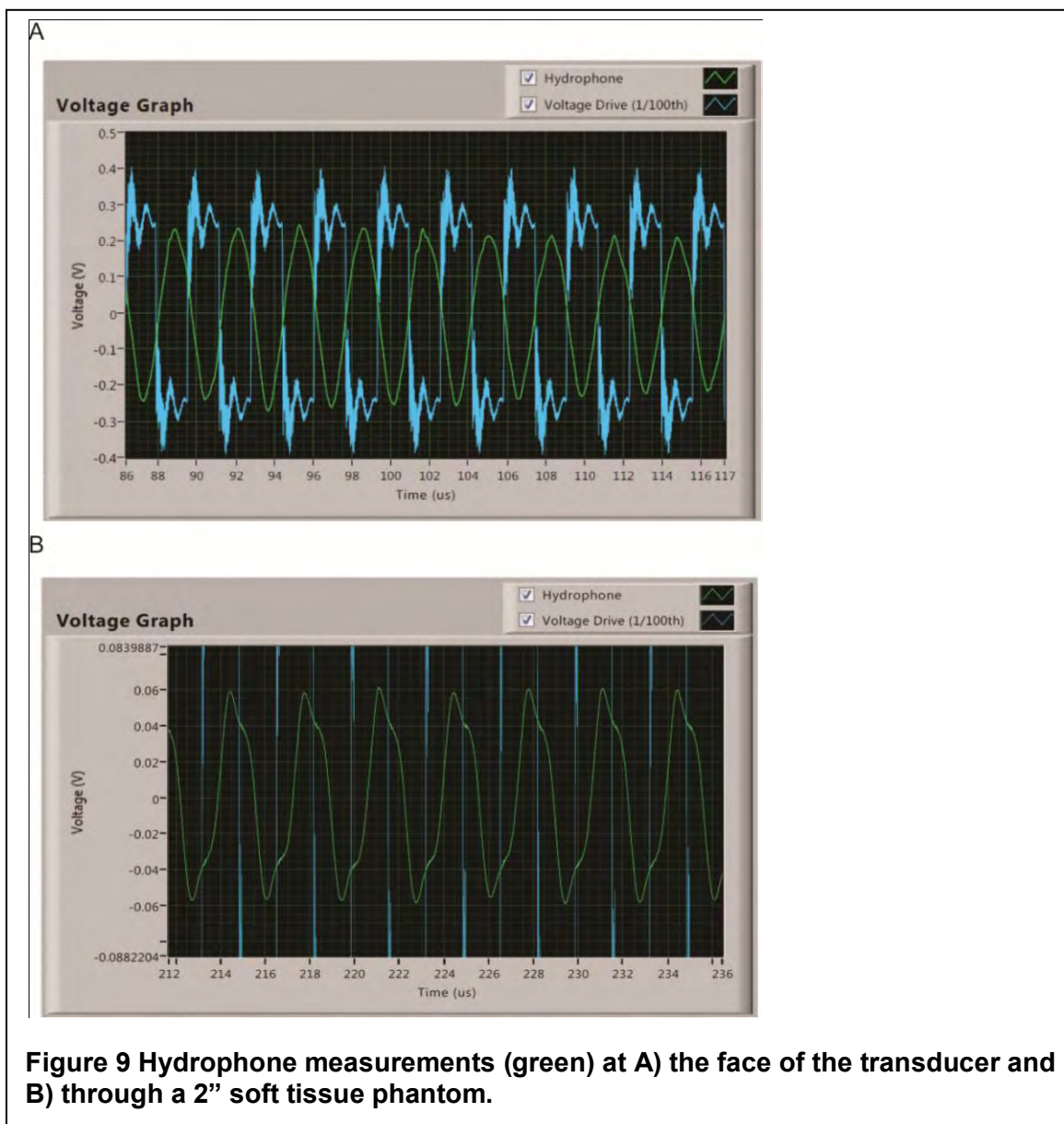

**Figure 8 Neurotrek V1.0**

### ***2.3 Characterization of the alpha prototype***

The initial testing we conducted with Neurotrek V1.0 was to determine the acoustic power and temperature increases delivered by the prototype using a soft tissue phantom. For this testing we used a Blatek 300 kHz transducer and a 2" piece of beef muscle for the phantom. Hydrophone measurements directly over the center of the transducer showed that the maximum spatial-peak pulse-average acoustic intensity (ISPPA) that can be delivered by the prototype is  $87.1\text{W}/\text{cm}^2$ , which is significantly higher than what is needed for UNMOD (Fig 9). The ultrasound field through a 2" inch piece of muscle had an ISPPA of  $8.0\text{W}/\text{cm}^2$  which shows that the prototype can deliver more than sufficient energy to deep tissues (Fig 9). A FLIR E60BX infrared thermal imaging camera and thermister probes were used to measure temperature changes in the soft tissue phantom and the transducer itself. Using waveform parameters that are consistent with what has been used for UNMOD

in previous studies (ISPPA=300mW/cm<sup>2</sup>, 100 cycles of 300kHz, 100 pulses at 1.5kHz pulse repetition frequency) elicited no detectable temperature changes in the transducer itself and minimal changes in the phantom. We used artificially high parameters to model the temperature changes in soft tissue as it relates to total energy delivered. Raising the intensity and duration to deliver a stimulus with roughly 9000 times the energy of a single UNMOD stimulus (ISPPA=87.1 W/cm<sup>2</sup>, 1.5 kHz pulse repetition frequency, 3000 pulses) led to significant heating of the transducer (Fig 10) and an 8.5°C change at the surface of the phantom (Fig 11). Modeling the heat increase showed that the increase in temperature was quite linear indicating that each acoustic cycle has a thermal dose. The maximum heating can then be estimated by multiplying the number of cycles delivered for a particular stimulus paradigm. Minor skin burns do not start to occur until 44°C and heat dissipation will be better in tissue with active circulation. These results indicate there is ample safety margin for delivering enough UNMOD energy while keeping the risk of burns through ultrasound-mediated tissue heating low. The temperature change in the opposite side of the 2" phantom was approximately 1.5°C (Fig 11) in line with approximately a 10-fold energy attenuation through the tissue. In this proposal we will outline strategies to address this attenuation using multiple transducers.





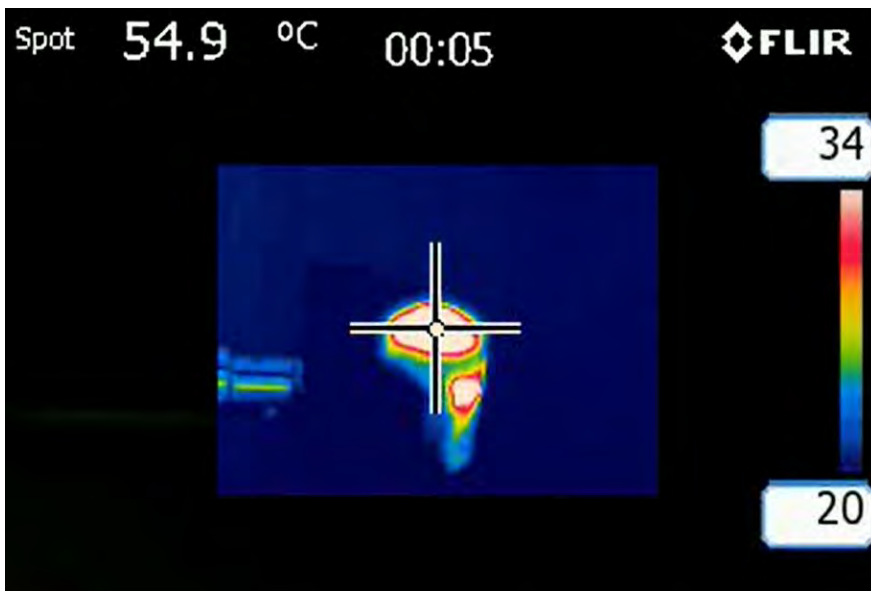

Figure 10. IR imaging using a FLIR camera of the face of the transducer at maximum output parameters.

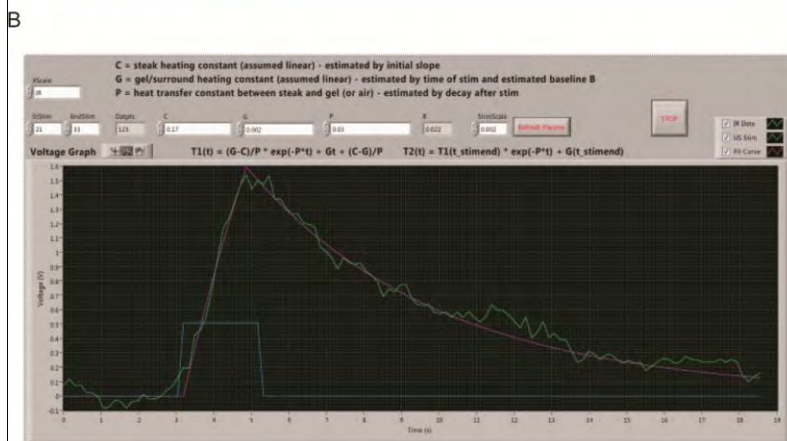
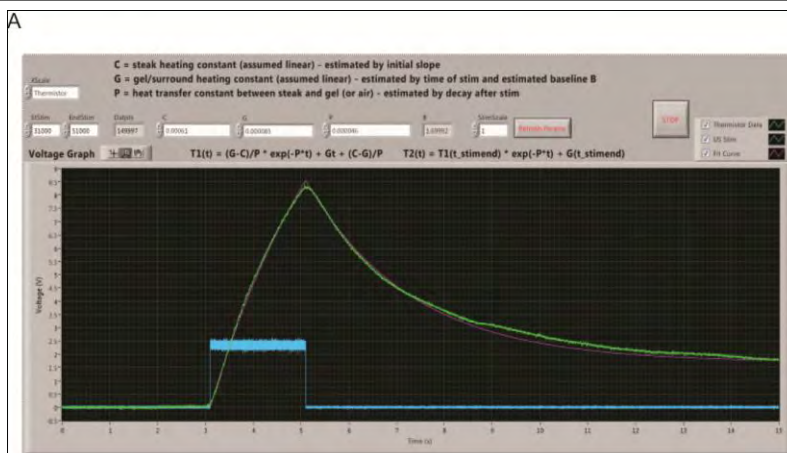

Figure 11. Thermister measurements after high power sonication at A) the surface of the phantom and B) through 2'' of soft tissue



### **3. Summary**

In the first phase of this effort we have completed several key milestones for the ultimate goal of delivering a technology that can be used to manage post-traumatic pain with ultrasound neuromodulation. Most importantly we have: 1) developed the software platform needed to deliver and test ultrasound neuromodulation, and 2) developed an alpha prototype that is relatively light-weight (10lbs) and capable of delivering sufficient acoustic intensity with low tissue heating. We hope to continue this progress in the Phase 1 Option and Phase 2. A summary of accomplishments is listed below.

#### ***Task 1 Software Development :***

- Data acquisition (hydrophones, thermocouples, electrophysiology)
- Complex waveform generation
- Automatic scanning for efficient parameters and undesirable characteristics (eg. adverse thermal changes)

#### ***Task 2 Developing a portable device enabling differential modulation of somatosensory circuits.***

- Waveform generation
- Adjustable stimulus repetition and duration
- Adjustable waveform shape and frequency
- Sufficient acoustic intensity for ultrasound neuromodulation
- Hand-held probe for testing in a variety of contexts

#### ***Task 3 Soft Tissue Experiments:***

- Thermal changes through soft tissue phantom seem acceptable
- Acoustic power and attenuation at various depths is more than sufficient for neuromodulation.