



**SIMPLIFIED DAYLIGHT SPECTRUM APPROXIMATION BY BLENDING
TWO LIGHT EMITTING DIODE SOURCES**

THESIS

Jacob M. Gilman, Captain, USAF

AFIT/GEM/ENV/12-M06

**DEPARTMENT OF THE AIR FORCE
AIR UNIVERSITY**

AIR FORCE INSTITUTE OF TECHNOLOGY

Wright-Patterson Air Force Base, Ohio

DISTRIBUTION STATEMENT A.
APPROVED FOR PUBLIC RELEASE; DISTRIBUTION IS UNLIMITED.

The views expressed in this thesis are those of the author and do not reflect the official policy or position of the United States Air Force, Department of Defense, or the United States Government. This material is declared a work of the United States Government and is not subject to copyright protection in the United States.

AFIT/GEM/ENV/12-M06

SIMPLIFIED DAYLIGHT SPECTRUM APPROXIMATION BY BLENDING TWO
LIGHT EMITTING DIODE SOURCES

THESIS

Presented to the Faculty

Department of Systems and Engineering Management

Graduate School of Engineering and Management

Air Force Institute of Technology

Air University

Air Education and Training Command

In Partial Fulfillment of the Requirements for the
Degree of Master of Science in Engineering Management

Jacob M. Gilman, BS

Captain, USAF

March 2012

DISTRIBUTION STATEMENT A.
APPROVED FOR PUBLIC RELEASE; DISTRIBUTION IS UNLIMITED.

SIMPLIFIED DAYLIGHT SPECTRUM APPROXIMATION BY BLENDING TWO
LIGHT EMITTING DIODE SOURCES

Jacob M. Gilman, BS
Captain, USAF

Approved:

//Signed//
Michael E. Miller, PhD (Chairman)

2 Mar 2012
Date

//Signed//
Alfred E. Thal, Jr., PhD (Member)

2 Mar 2012
Date

//Signed//
Michael R. Grimaila, PhD, CISM, CISSP (Member)

2 Mar 2012
Date

Abstract

Energy-conscious facility designs strive to include natural daylight in workspaces. To improve the efficiency of illumination, significant efforts are underway to adopt more efficient light emitting diode (LED) lamps and to effectively integrate daylight with active dimming of electric lighting. However, the correlated color temperature (CCT) and spectral content of daylight varies throughout the day while existing electric light sources produce light with a fixed CCT, resulting in mixed-illumination environments. The color rendering requirements for a lamp that permits the selection of color temperature across a significant portion of the daylight locus is explored. The analysis indicates that it is possible to form a lamp having only two independently controllable groups of narrowband emitters which is capable of producing light that achieves a nearly colorimetric match to daylight from 4000 to 10,000 K. A prototype LED lamp, with a simple control and novel drive scheme, which produces white light over a range of CCTs by blending light from a pair of sources, each with numerous, tuned LED emitters, is demonstrated. The prototype validates the lamp concept; producing light over a broad range of CCT values (4000 to 8000 K) while maintaining a stable color quality rendering score without requiring computations for spectral approximation once employed.

To my wife and parents for their unending support.

Acknowledgments

My sincerest appreciation goes to my research advisor, Dr Michael Miller, for his patience, guidance, and infectious passion for lighting throughout the course of this thesis effort. The knowledge and experience he brought to this endeavor was instrumental in opening my eyes and mind toward a whole new light.

I also extend my gratitude to Dr Michael Grimaila for his interest in my electronic endeavors, technical support, and oscilloscope — without which it's all just magic.

Jacob M. Gilman

Table of Contents

	Page
Abstract.....	iv
Dedication.....	v
Acknowledgments.....	vi
Table of Contents.....	vii
I. Introduction.....	1
II. Article 1 – Simple Daylight Matching with Blended-CCT LED Lamp.....	6
Abstract.....	6
Background & Objective.....	6
Method.....	10
Results.....	14
Conclusions.....	19
Acknowledgements.....	20
Disclaimer.....	20
References.....	20
III. Article 2 – Simplified Daylight-Matched LED Lamp with Blended Fixed-CCT Sources.....	22
Abstract.....	22
Keywords.....	22
Introduction.....	23
Method.....	28
Results.....	39
Conclusions.....	44
Acknowledgments.....	45
Funding.....	45
Conflict of Interest Statement.....	45
Disclaimer.....	45
References.....	46
Author biographies.....	48

	Page
IV. Article 3 – Daylight-Matched Lighting for Mixed Illumination Environments	50
Abstract.....	50
Background.....	50
Proposed Lamp Concept.....	53
Method.....	56
Results.....	57
Conclusions.....	59
Acknowledgements.....	60
References.....	60
V. Article 4 – A Proposed Lamp for Daylight-Matched Illumination	62
Summary.....	62
Introduction.....	63
Lamp Description	66
Analysis	68
Color Temperature Range.....	69
Fidelity Metric	70
Technology Constraints	73
Analysis Method.....	74
Results.....	75
Conclusion	80
References.....	82
Biographies	85
List of Figures.....	87
Figures	89
Tables.....	95
VI. Conclusions and Recommendations.....	101

SIMPLIFIED DAYLIGHT SPECTRUM APPROXIMATION BY BLENDING TWO LIGHT EMITTING DIODE SOURCES

I. Introduction

Existing facilities are full of light which is necessary the majority of the time for successful task completion. Often, little thought is given to the energy consumption, source, color, quality, or intensity of the light until that source of illumination fails in some way, causing a disruption in productivity, decreased enjoyment, or shift in the agreeableness of occupants. Daylight, the visible portion of the electromagnetic spectrum radiated by the Sun which reaches the Earth, has been the predominate source of light over the course of human development. Only recently in man's existence has the electric lamp become a source of illumination for the portion of the population that work inside facilities. It is from technical, indoor work that many technologies have been born and research has been conducted which now highlight both the inefficiencies of existing electric lighting technology and the promises of new, improved lighting alternatives.

Electric lamps exist in many forms and employ technology for producing light ranging from simple, such as incandescent, to more complex methods, such as electrodeless magnetic induction. Typical facility electric lamps include incandescent, florescent, and high-intensity discharge. Each type of electric lamp has its own characteristics associated with converting electric energy into visible light. Therefore, electric lamps are often classified and identified according to efficacy, correlated color temperature (CCT), and color rendering score.

A lamp's efficacy expresses how well electrical energy is converted into light visible to the human eye and is often expressed in lumens per watt (lm/W). When comparing lamps, a higher efficacy number indicates that a particular lamp is more efficient in the use of supplied electrical energy than another. The color of white light, whether daylight or produced by an electric lamp, is formally expressed as a correlated color temperature (CCT) in degrees Kelvin (K). Light with low CCTs, such as the light produced by most incandescent lamps, is often referred to as "warm white" and light with higher CCTs, such as the light produced by linear fluorescent lamps, as "cool white". The majority of electric lamps are only capable of producing light at one, fixed CCT. On the other hand, daylight varies, for example, from low CCTs in the morning, to mid-level (6500 K) CCTs in a clear noonday sky, to higher CCTs under overcast skies.

While efficacy and CCT are good metrics for describing a light source, a color rendering score is critical to understanding the way colors will be perceived by the human visual system when illuminated by an electric lamp. Many metrics exist, the most common being the Color Rendering Index (CRI). In all cases, a higher number indicates that a particular lamp does a better job than another lamp having a lower score at reproducing the same perceived color when reflected from an object as when a reference light source (e.g., a daylight source) is used to illuminate the same object. A CRI score of 100 indicates that colors are accurately reproduced and appear as they would under a reference light source, such as daylight at the same CCT.

Over the last decade, inorganic light emitting diode (LED) technology has rapidly emerged into the facility lighting arena. These semiconductor-based devices have ushered in a new category of electric lamp known as solid-state lighting (SSL). LEDs

have a high efficacy, a long lifespan, the capability to produce light at a variety of CCTs and CRI levels, the ability to dim without suffering drastic CCT shifts, the ability to rapidly switch on and off, and are insensitive to vibration and shock. SSL facility illumination options are increasing as LEDs continue to demonstrate increasing efficacy, while presently producing light with an efficacy comparable with or in excess of the other traditional, efficient technologies discussed above. Additionally, organic light emitting diode (OLED) technology, although developmentally several years behind inorganic technology, is also being developed for application in the facility lighting industry.

Energy consumption is a key concern for many facility owners and operators as costs continue to rise. As a subset, facility electrical energy consumption continues to be the target of energy reduction goals at governmental, corporate, and individual levels. One way to reduce daytime electrical loads is through the integration of daylight into the facility space and the upgrade of existing electric lamps to more efficient technology. Methods vary for collecting, transporting, and distributing daylight within a facility, but all work in a similar fashion by bringing daylight into the workspace. This daylight serves as the primary or supplementary light source for occupants and often requires supplemental light from electric lamps in order to achieve required luminance levels within the facility space. This facility lighting scheme is challenging since the intensity and CCT of daylight naturally shifts over the course of a typical day. Supplementing available daylight with light from traditional electric sources will result in spaces being illuminated with light at different CCTs. This mixed-CCT environment impacts the way the human visual system processes color information. Human perception of color adapts based upon the predominate light source's CCT. For example, two objects of the same

color will appear to be different colors if one is illuminated by the primary source of illumination and the other is illuminated by a light source of a different CCT, such as a desktop task lamp. The effects of this phenomenon can range from mildly distracting to critically confusing if colors are similar and the distinction among them is essential for task completion. These effects may be mitigated by supplementing the available daylight with additional electric light from lamps capable of varying their CCT to match, and spectra to approximate, that of the existing daylight.

Leveraging the advantages of LED technology over that of traditional electric lamps provides the framework for an LED-based daylight-matching lamp concept and is the subject of this thesis. Matching daylight CCT with LED lamps is possible and has been demonstrated, but often requires significant ongoing calculations to achieve a quality color rendering and CCT match when employed. A simpler approach is presented and developed throughout the following chapters whereby two separate LED sources at different, fixed CCT points are blended together to produce white light with a spectra approximating standard daylight over a typical CCT range. This blended, fixed-CCT source LED lamp concept and novel electronic driving scheme is modeled, implemented in a prototype, evaluated, and demonstrated to achieve positive results.

The following is intended to provide the reader with a cursory overview and organizational structure of the articles in the following chapters. Article 1 (Chapter 2), which has been accepted for publication at the 2012 Society for Information Display Conference, presents the concept, computer modeling process, prototype lamp development, and measured results used for model verification and improvement. Article 2 (Chapter 3), which has been formatted for submission to the Lighting Research and

Applications Journal, builds upon Article 1 but offers an in-depth explanation of the novel LED driving scheme and prototype hardware, measurement configuration, computer model development largely covered by Article 1, abbreviated results, and a discussion of application beyond inorganic LEDs. Article 3 (Chapter 4), which has been published at the 2011 Illuminating Engineering Society Conference, introduces the concept of blending two fixed-CCT sources to produce spectra at intermediate CCTs. Additionally, Article 3 investigates, through computer modeling, the minimum number of LED spectral peaks required to achieve a Color Fidelity Score (CFS) of at least 85 over a CCT range of 5000 to 10,000 K when the center frequency locations of the LEDs and OLEDs are not restricted. Article 4 (Chapter 5), which has been submitted for review to the Color Research and Applications Journal, expands on the material developed in Article 3, applying additional metrics to aid the optimization process over an expanded CCT range of 4000 to 10,000 K. Additionally, Article 4 compares the results of the standard approach, whereby LED and OLED center frequencies are uniquely selected in each source, to a restricted approach which requires the center frequencies of respective peaks to be at the same location in both the low and high CCT sources to simplify the design and fabrication of the final device.

The blending concept developed and supported by prototype testing in Articles 1 and 2 is expanded in application with the inclusion of Articles 3 and 4. When taken together, the four presented articles pave the way for future research and developed toward higher quality, simpler, daylight-matching LED lamps.

II. Article 1 – Simple Daylight Matching with Blended-CCT LED Lamp

Simple Daylight Matching with Blended-CCT LED Lamp

Jacob M. Gilman

Engineering Management Program, Air Force Institute of Technology,
Wright-Patterson AFB, OH, USA

Michael E. Miller, PhD

Dept. of Systems and Engineering Management, Air Force Institute of Technology,
Wright-Patterson AFB, OH, USA

Abstract

Energy-conscious facility designs strive to include natural daylight in workspaces. Daylight's correlated color temperature (CCT) varies throughout the day and conflicts with existing fixed-CCT artificial light sources, delivering poor color rendering for users. A prototype blended-CCT LED lamp demonstrates a simple control concept for matching daylight variations.

1. Background & Objective

Recently, published building construction guidelines [1] have placed an increased emphasis on sustainability. With respect to illumination, these guidelines suggest designs with an increased reliance on natural light to reduce the amount of electric light and associated power. However, it will often be impractical to rely entirely on natural

illumination, requiring a mixture of natural and electric light to achieve the desired level of illumination within most office environments.

Unlike traditional electric light, which typically has a constant color, the color of light provided by natural illumination can vary throughout the day. One commonly used metric to describe this change in color is the correlated color temperature (CCT) of the illumination, which can vary from 2000 Kelvin (K) at sunrise through 5000K for direct daylight at noon and can exceed 10000K in overcast conditions. Daylight during the course of a typical workday varies between 5500K and 7500K over both clear and overcast conditions when solar elevation is greater than 10 degrees [2]. In our natural environment, this change in the color of natural light is not noticeable as only natural light is present and our visual system adapts to the changing color of the light.

In mixed illumination environments, natural and electric light will be simultaneously present and each source can illuminate neighboring areas of the environment. As the color of electric light is typically constant and the color of the natural light changes during the day, multiple colors of illumination will be simultaneously present in these mixed illumination environments. Our visual system will, therefore, adapt to a color of illumination somewhere between the colors of the two illumination sources. As a result, the difference in the color of illumination from the two sources can be evident and potentially undesirable for optimal task performance.

As noted earlier, color temperature is one potential metric of the color of the illumination. Although this metric describes the overall change in color, this metric provides only an approximate description of the color of the light emitted by a lamp and does not describe the perceived colors of objects in an environment as light from the

source is reflected from them. Other metrics, such as the Color Rendering Index (CRI), Color Fidelity Scale (CFS), and Color Quality Scale (CQS) are necessary to better describe the quality of electric illumination [3].

Another trend in lighting design is a movement towards the adoption of new technologies, including inorganic and organic light-emitting diodes [4, 5]. This technology has the potential to provide greater energy efficiency compared with traditional tungsten and fluorescent lamps [6]. Additionally, these technologies provide narrowband emission, the center frequencies of which can be tuned or combined with other technologies, such as quantum dots [7-9] to create lamps with multiple, frequency-selectable, spectral peaks. Through selective application, the relative emission at each of the narrow emission bands can be controlled to permit the accurate selection of color from these solid-state devices.

Previous literature discussing lamps with color that is adjusted to match the color of daylight have used numerous independently-controlled light sources [10]. Although such lamps can accurately reproduce the color of daylight, because three or more different light sources must be independently controlled, the electronics and algorithms required to achieve a color match can become complex and potentially costly to implement. Alternately, such systems can require the user to adjust the color and luminance of the lamp by manipulating several controls which operate in a non-intuitive manner.

The goal of this paper is to demonstrate a simpler lamp concept capable of producing a colorimetric match to standard daylight over a typical CCT range. This lamp concept uses only two light sources which are then blended together to match a desired

CCT and standard spectra of daylight at intermediate CCT values. Previous research [11] demonstrated a lamp having independently-controlled cyan and yellow-white emitters that could be controlled to create a wide range of correlated color temperatures. Unfortunately, the lamp did not match the spectrum of daylight. The authors have recently discussed a concept lamp capable of matching the color temperature and standard spectra of daylight over a broad range of color temperatures [12]. As proposed, this concept lamp permits the ratio between two independently-controlled white emitters, one having a high and one a low CCT point, to move the lamp's chromaticity point along a straight line between the two points on or near the blackbody locus as illustrated in Figure 1.

This approach reduces computational effort for solutions between the two selected end points. Since the two respective light sources only need to be dimmed proportionally to each other, individual intensities are not calculated, eliminating the need to compute individual dimming solutions for all desired daylight CCT points and providing a single, intuitive dial to adjust the perceived color of the lamp's output.

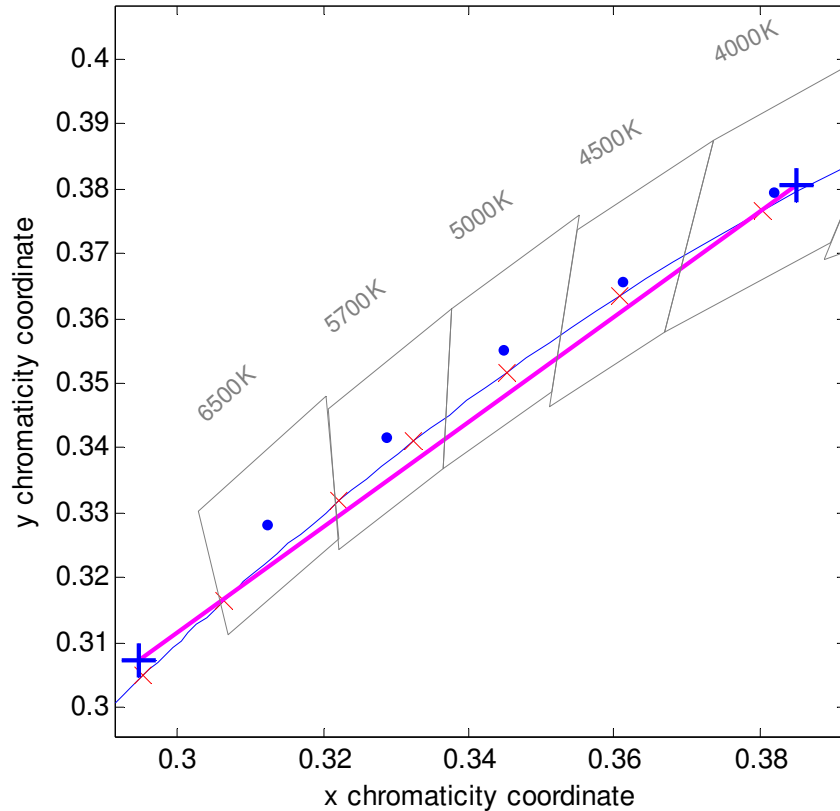

Figure 1 – Blending illustration showing two selected end points (heavy cross) and the available solutions (heavy straight line). Standard ANSI CCT boxes and blackbody locus are shown for reference.

2. Method

A prototype lamp was designed to demonstrate the authors’ standard daylight match-by-blending concept. This prototype employs commercial off-the-shelf LEDs, current drivers, heat sinks, and power supply, along with custom TTL/CMOS IC logic circuitry to demonstrate the concept. While LEDs were not readily available to demonstrate a high quality match (as determined by earlier work [12]) to standard daylight spectra, the prototype was demonstrated to create a reasonable match to standard daylight and permit the validation of a colorimetric model for designing such a lamp. In

this lamp, each of the two independently-controlled white emitters are composed of a string of four commercially-available high-brightness LEDs with center wavelengths at 464, 512, 598, and 634nm as shown in Figure 2.

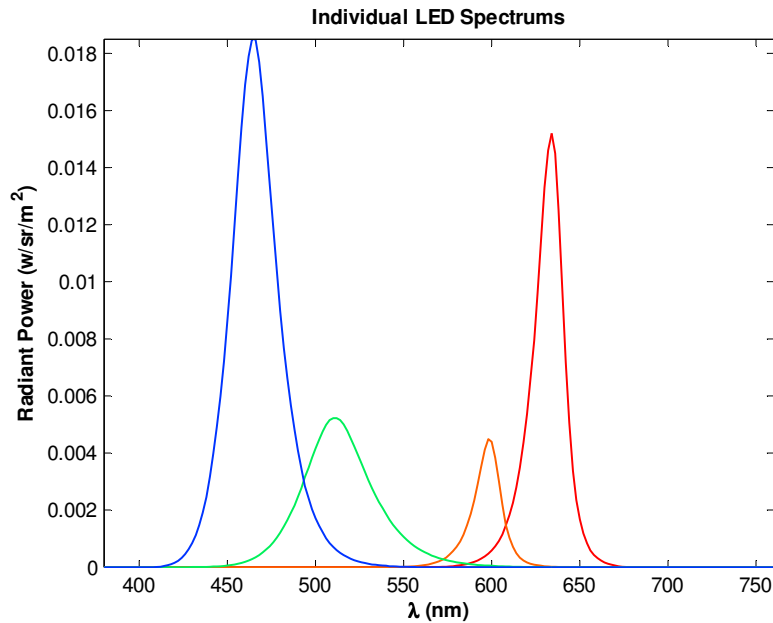

Figure 2 – Comparison of selected LEDs’ radiant power over visible spectrum.

Power to each of eight LEDs is provided by separate constant current drivers which are capable of accepting pulse width modulation (PWM) signals from additional control logic. Control logic was constructed which is capable of accepting a given dimming solution set for each string of four LEDs to be loaded into the lamp to produce light at the desired CCT point. The controlling logic allows for 16 levels (4 bits) of dimming as well as a disabled state for each LED. The ability to manually blend the light from the two light sources by adjustment of one control is also included through the integration of a precision potentiometer (R_1) which provides 1,000 repeatable, potential blending levels. When the potentiometer is set to the lowest value, [000], source A is at

its maximum luminance and source B is at its minimum; at the highest value, [999], source A is at its minimum luminance and source B is at its maximum. At any other value, the luminance of source A and source B are blended proportionally. For example, at a value of [300] the contribution of source A is 70% and source B is 30%. The combined dimming and blending PWM signals are sent to the respective constant current drivers at a nominal clock frequency of 9.6kHz.

Computer modeling is used to determine a dimming solution for each of the four LEDs, in each of the two strings, to achieve an acceptably-close colorimetric match at both a low and a high CCT point as shown in Figure 3. The Matlab[®] model accepts user inputs for LED spectra, bounded low and high CCT targets, and minimally acceptable CQS and CRI scores. Two spectra input methods were explored, both of which consisted of intensity values along wavelengths from 380nm to 760nm at a spacing of 2nm.

The first spectra input method consisted of four separate spectra given as the maximum measured spectral intensity for each of the four LEDs in the first source. Each spectra was then linearly scaled by the model to provide 17 dimming levels for processing.

The second spectra input method consisted of 128 separate spectra given as the measured spectral intensity for each of the eight LEDs comprising the two sources over the 16 available dimming levels as driven by the control logic. The disabled state was amended by the model to provide a total of 17 spectra for each LED for processing by the model.

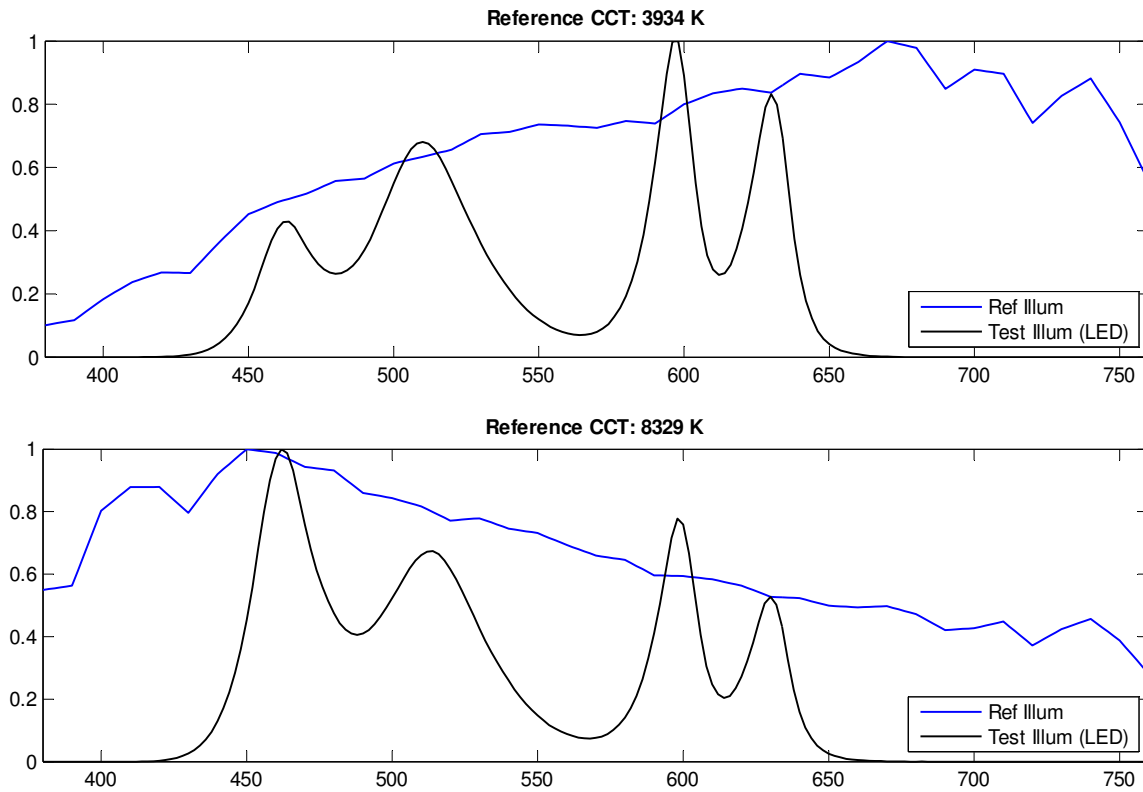

Figure 3 – Model-generated low CCT (top) and high CCT (bottom) LED spectra and corresponding daylight targets.

The model executes an iterative, exhaustive search method for the low CCT source solution. All possible 4-LED, 4-bit, dimming combinations are searched and those with CQS or CRI scores above the specified minimum thresholds are retained for additional processing. The dimming solution with the highest CRI score, as computed against a target-matched daylight spectrum, is selected as optimal. This process is then repeated to find a solution for the high CCT target.

The model returns a four element dimming solution and CRI score (using a solution-matched standard daylight spectra) for both target CCT points along with predicted CQS scores for 100 points along the straight line connecting the two sources.

Source CCT targets of 4000K and 8000K were selected, since typical daylight would fall within this range, and bounded at 3800 – 4300K and 7800 – 8500K, respectively. CQS and CRI minimum scores were set at 55 and 40, respectively, for both sources.

Spectral data were collected from the lamp output using a Photo Research SpectraDuo[®] PR680L spectroradiometer and SRS-3 diffuse reflectance standard over eleven blending ratios by setting R_1 to [000, 100, 200, 300, 400, 500, 600, 700, 800, 900, and 999].

3. Results

The computer model, using the first spectra input method, returned an optimal solution set; however, the prototype's response (Figure 4) was a poor match to the model's predictions.

The lamp's output for the low CCT source was close to the desired target, but the high CCT source was far from the desired chromaticity coordinates. However, blending the two sources did produce light with coordinates generally following a straight line between the low and high CCT sources. Examination of the spectra under various isolated dimming conditions revealed that most noticeably the peak amplitude of each LED did not follow a linear trend over the full dimming range. The model assumed amplitudes varied linearly and applied a linear scaling to the entered spectra during processing.

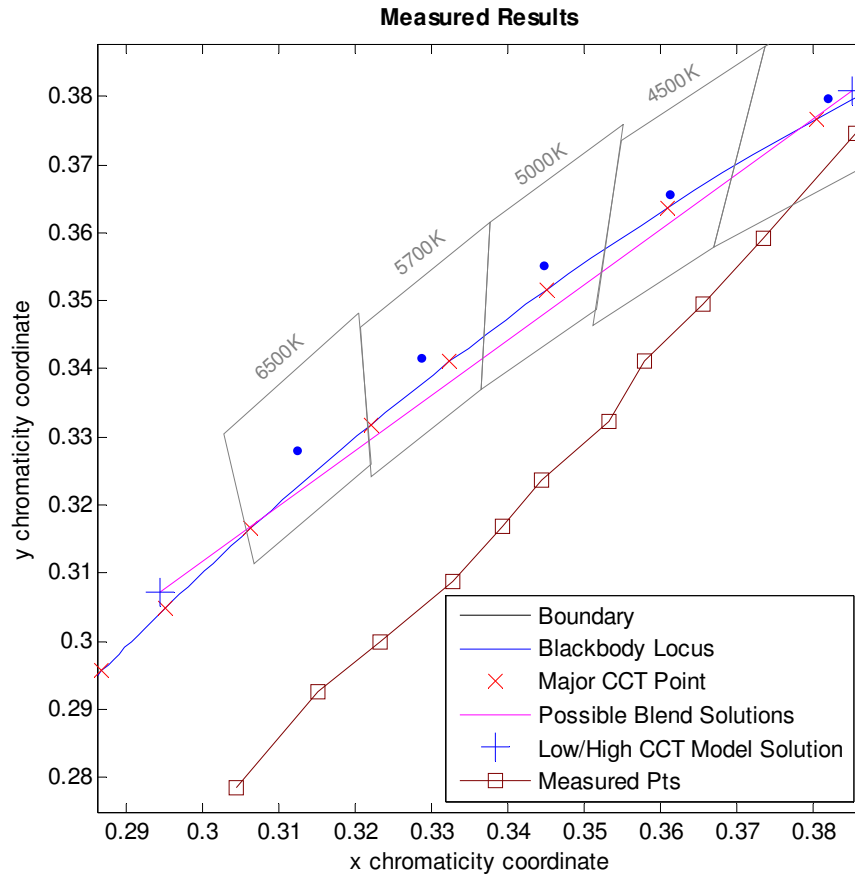

Figure 4 – Measured lamp response over 11 blending steps using model solution from first spectra input method.

Since the objective was to demonstrate the concept of standard daylight matching by blending fixed CCT sources comprised of either inorganic or organic LEDs, precise computer modeling of, in this case inorganic, LED responses for solution generation was not pursued. Instead, the second spectra input method, which yielded a contrasting and improved prototype response, was adopted.

The computer model, using the second spectra input method, returned the solution set shown in Table 1 and generated the predicted combined spectra shown in Figure 3 for

the low and high CCT source points. This dimming solution was loaded into the prototype's control logic for measurement and evaluation.

Table 1 – Dimming solution set produced by computer model. Values represent scaling factor applied relative to each LED's maximum power spectra.

Point	CCT	CRI	Red	Amber	Green	Blue
Low	3934	62	0.1875	0.6875	0.4375	0.0625
High	8329	59	0.1875	1.0000	0.9375	0.2500

The prototype's response with the solution set of Table 1 is shown in Figure 5. The data shown in Figures 5, 6, and 7 are the arithmetic mean values of three separate, repeated measurements of the prototype lamp's output. The blending concept presented by the authors is supported by the results obtained from the lamp. The blended points, depicted as squares in Figure 4, generally follow the straight-line blending trend predicted by the model, which is represented by the straight line connecting the two endpoints. The mid blending point, at which both sources are contributing 50% of their maximum output, dips noticeably below the target blending line around a CCT of 5500K, however the lamp's chromaticity coordinates remained within the standard ANSI color temperature boxes for solid-state lighting. Additionally, points on the warm side of the midpoint fell below the target line, whereas points on the cool side fell above the target line. The lamp's output also demonstrated unequal steps in CCT between blended points; most notably between the extreme endpoints (source points) and the first blended step inward. Discounting the extreme ends of the range, the overall trend revealed larger steps in CCT as blending moved toward the high CCT source. Even with these discrepancies

between model and measured results, the lamp's response was markedly better than those obtained by using the first spectra input method. A simple regression ($R^2 = 0.997$) shows that a desired CCT is obtained, over the designed minimum and maximum range, by adjusting the value of R_1 as shown in Eq. 1.

$$R_1 = -3 \times 10^{-5} \cdot CCT^2 + 5.9 \times 10^{-1} \cdot CCT - 1.9 \times 10^3 \quad (1)$$

As discussed earlier, a CCT match alone does not adequately specify the performance of the lamp since a colorimetric match to standard daylight is desired. The prototype's ability to provide a colorimetric match to daylight is evaluated using the CQS scoring method described in detail in [3]. The three-point measured average CQS score of the lamp's output is shown in Figure 7 along with the model's predicted scores over the design range.

With the exception of the two highest measured CCT points, the lamp spectra returned a CQS score which was relatively constant and slightly greater than the model prediction. While a CQS score in the upper 60's is not ideal, nor practical for critical lighting applications, it was found to be among the best available from 4-LED blended sources for which the center frequencies were not optimized.

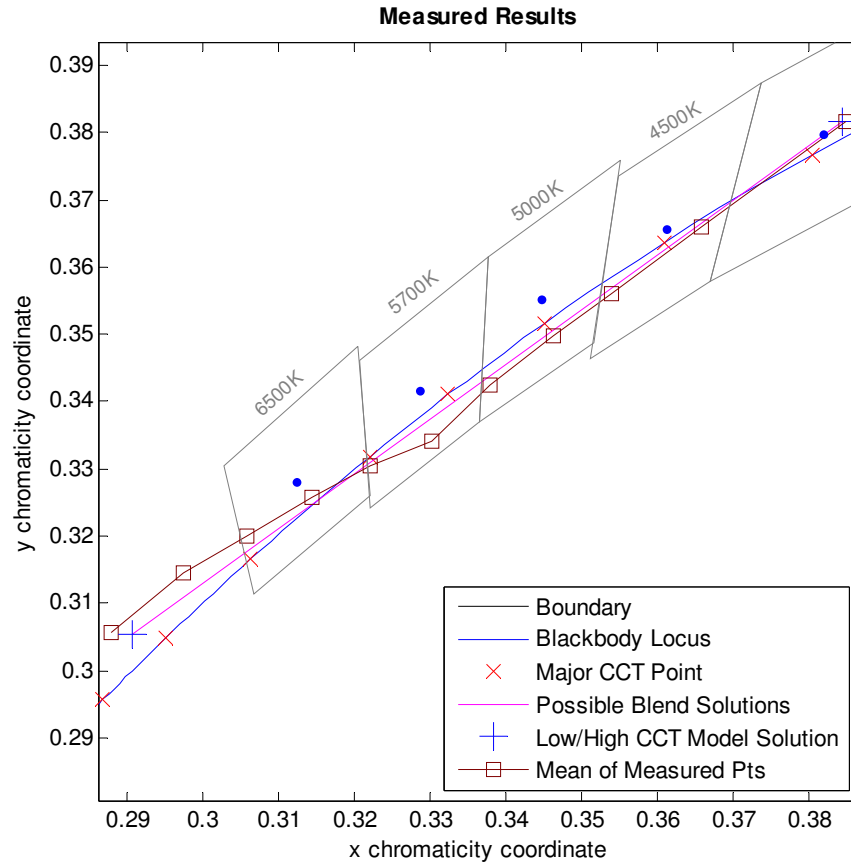

Figure 5 – Lamp response measured over 11 blending steps. Blended illuminant chromaticity coordinates shown by squares. Model’s possible blended solutions indicated by straight line between model’s solution sources (+).

Figure 6 shows that the lamp’s overall luminance levels follow a linearly increasing trend within the 10-90% blending range. No effort was made to force the model toward a solution containing sources with equal individual luminance levels as well as maximized colorimetric matches. The greater luminance value of the high CCT source was to be expected since the model’s solution set indicated that the amber, green, and blue LEDs be driven at a greater power level than those of the low CCT source.

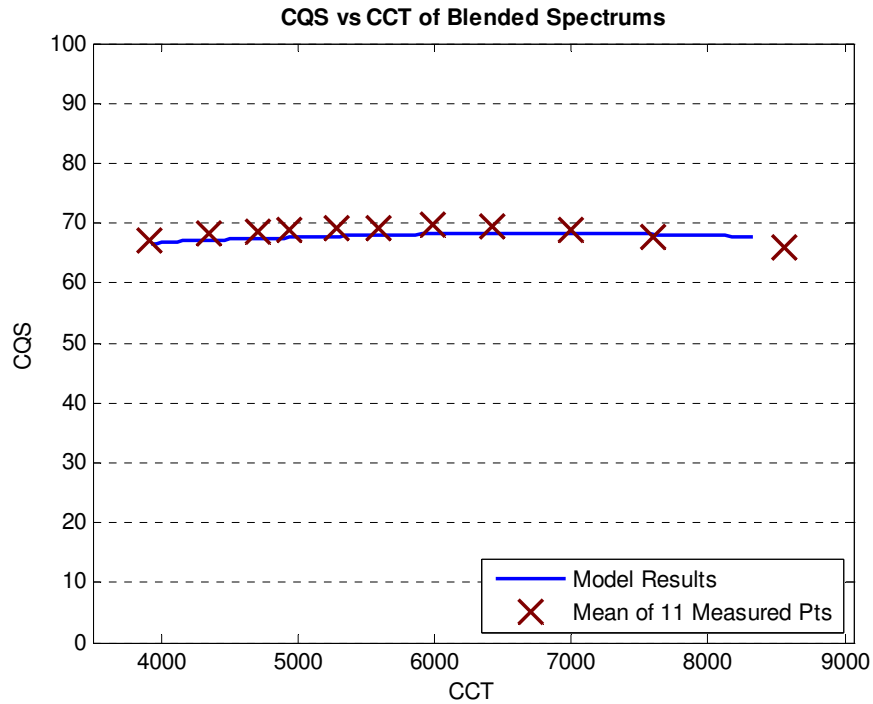

Figure 6 – Color Quality Scale score vs. CCT of mean of measured points and model prediction (solid line).

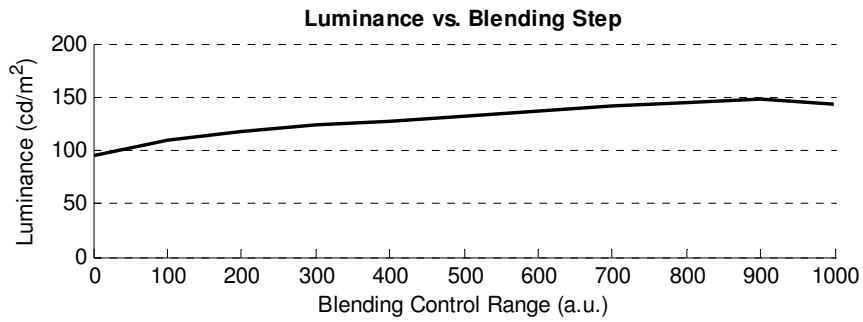

Figure 7 – Overall lamp luminance as a function of the blending ratio between low and high CCT.

4. Conclusions

This prototype demonstrated that daylight matching is possible by blending two fixed-CCT sources without the need for ongoing complex calculations when the lamp is

employed and that selection of desired CCT points is easy and repeatable. Additionally, the resulting blended points were demonstrated to have quality score equal to or higher than the unblended high and low CCT sources. Further research is needed to understand the color shifts related to the employed PWM strategy and the offset between the model and lamp performance.

5. Acknowledgements

The authors would like to acknowledge the Air Force Institute of Technology (AFIT) and the Air Force Civil Engineer Support Agency (AFCESA) for sponsoring the current project.

6. Disclaimer

The views expressed in this thesis are those of the author and do not reflect the official policy or position of the United States Air Force, Department of Defense, or the United States Government.

7. References

- [1] ASHRAE. *Advanced Energy Design Guide for Small Office Buildings*. 2004.
- [2] J. Hernández-Andrés, J. Romero, J. L. Nieves and R. L. Lee Jr. Color and spectral analysis of daylight in southern europe. *JOSA A* 18(6), pp. 1325-1335. 2001.
- [3] W. Davis and Y. Ohno. Color quality scale. *Optical Engineering* 49, pp. 033602. 2010.
- [4] C. Kuo, R. Fletcher, T. Osentowski, M. Lardizabal, M. Craford and V. Robbins. High performance AlGaInP visible light-emitting diodes. *Appl. Phys. Lett.* 57(27), pp. 2937-2939. 1990.
- [5] C. W. Tang and S. A. VanSlyke. Organic electroluminescent diodes. *Appl. Phys. Lett.* 51(12), pp. 913-915. 1987.

- [6] R. Lenk and C. Lenk. *Practical Lighting Design with LEDs* 2011.
- [7] B. O. Dabbousi, J. Rodriguez-Viejo, F. V. Mikulec, J. R. Heine, H. Mattoussi, R. Ober, K. F. Jensen and M. G. Bawendi. (CdSe)ZnS core-shell quantum dots: Synthesis and characterization of a size series of highly luminescent nanocrystallites. *J Phys Chem B* 101(46), pp. 9463-9475. 1997.
- [8] S. Nizamoglu, E. Mutlugun, T. Özel, H. V. Demir, S. Sapra, N. Gaponik and A. Eychemüller, "Dual-color emitting quantum-dot-quantum-well CdSe-ZnS heteronanocrystals hybridized on InGaN/GaN light emitting diodes for high-quality white light generation," *Appl. Phys. Lett.*, vol. 92, pp. 113110. 2008.
- [9] J. Zou, J. Liu, H. Wu, W. Yang, J. Peng and Y. Cao. High-efficiency and good color quality white light-emitting devices based on polymer blend. *Organic Electronics* 10(5), pp. 843-848. 2009.
- [10] M. Aldrich. *Dynamic solid state lighting*. 2010.
- [11] Color temperature-regulable LED light, Y. Okumura. Dec 30, 2004. *US 2004/0264193 A1*. 2004.
- [12] M. E. Miller and J. M. Gilman, "Daylight-matched lighting for mixed illumination environments," in *Proceedings of the IES Conference*, Austin, TX. 2011.

III. Article 2 – Simplified Daylight-Matched LED Lamp with Blended Fixed-CCT Sources

Simplified daylight-matched LED lamp with blended fixed-CCT sources

Jacob M Gilman, Michael E Miller and Michael R Grimaila

Air Force Institute of Technology, Wright-Patterson Air Force Base, Ohio, USA

Abstract

Energy-conscious facility designs strive to include natural daylight in workspaces. However, the correlated color temperature (CCT) and spectral content of daylight varies throughout the day while existing electric light sources produce light with a fixed CCT, resulting in mixed-illumination environments. A prototype LED lamp, with a simple control concept, which produces white light over a range of CCTs by blending light from a pair of sources is proposed. A prototype is developed to demonstrate the lamp concept, which is capable of producing light over a broad range of CCT values while maintaining a stable color quality rendering score with respect to a standard daylight source with an equivalent CCT. This range of CCTs is obtained without requiring computations for spectral approximation once employed, resulting in a simplified control scheme.

Keywords

Color rendering index, color fidelity score, daylight, lamp, CCT, LED

Introduction

Recently, published building construction guidelines¹ have placed an increased emphasis on sustainability. With respect to illumination, these guidelines suggest designs with an increased reliance on natural light to reduce the amount of electric light and associated power consumption required to provide sufficient task illumination. However, it will often be impractical to rely entirely on natural illumination, requiring a mixture of natural and electric light to achieve the desired level of illumination within most office environments. A review of available hybrid lighting systems, those which provide both day and electric light from the same luminaries, reveals that while existent technology meets sustainability design challenges, all systems provide supplemental electric light by largely traditional means: metal halide, sulfur, linear fluorescent, compact fluorescent, or incandescent lamps.² Unlike traditional electric light, which typically has a constant color, the color of light provided by natural illumination can vary throughout the day. One commonly used metric to describe this change in color is the correlated color temperature³ (CCT) of the illumination, which can vary from 2000 Kelvin (K) at sunrise through 5000 K for direct daylight at noon and can exceed 10 000 K in overcast conditions. The CCT of daylight during the course of a typical workday varies between 5500 K and 7500 K over both clear and overcast conditions when solar elevation is greater than 10 degrees while lower color temperatures are experienced only during early morning or late evening when the solar elevation is less than 10 degrees.⁴ In our natural environment, this change in the color of natural light is often not noticeable as only natural light is present and our visual system adapts to the changing color of the light.

When employing hybrid lighting systems, natural and electric light will be simultaneously present and each source can illuminate neighboring areas of the environment. As the color of electric light is typically constant and the color of the natural light changes during the day, multiple colors of illumination will be simultaneously present in these environments. Our visual system will, therefore, adapt to a color of illumination somewhere between the colors of the two illumination sources. As a result, the difference in the color of illumination from the two sources can be evident^{2, 5-7} and potentially undesirable for optimal task performance. Additionally, given the opportunity to manually control the mixing of natural and electric light sources, individual users prefer different levels of mixed illumination than others over the course of the day,⁸ attempting to optimize their own agreeableness⁹ given a particular daylight delivery system.

As noted earlier, color temperature is one metric of the color of the illumination. Although this metric describes the overall change in chromaticity, this metric provides only an approximate description of the color of the light emitted by a lamp in a given environment and does not describe the perceived colors of objects in an environment as light from the source is reflected from them. Other metrics, such as the Color Rendering Index (CRI), Color Fidelity Scale (CFS), and Color Quality Scale (CQS) are necessary to better describe the quality of electric illumination with respect to daylight illumination.¹⁰ While consensus is growing that CRI has several shortcomings when applied to evaluate and optimize solid-state lighting (SSL), a replacement rendering index has not been agreed upon. Many alternatives and methods have emerged¹¹ and some authors have suggested the use of two or more metrics to better understand the quality of light

produced by white light lamps when the light is produced by multiple emitters having narrow emission bands.¹²

Another trend in lighting design is a movement towards the adoption of new technologies, including inorganic (LED) and organic (OLED) light-emitting diodes.^{13, 14} These technologies have the potential to provide high energy efficiency compared with traditional tungsten and fluorescent lamps.¹⁵ Additionally, these technologies provide narrowband emission, the center frequencies of which can be tuned or combined with other technologies, such as quantum dots¹⁶⁻¹⁸ to create lamps with multiple, frequency-selectable, spectral peaks. Through selective application, the relative emission at each of the narrow emission bands can be controlled to permit the accurate selection of color from these solid-state devices.

LED SSL lamps can produce white light in two general ways; either by a UV or blue LED pumping a yellow phosphor or other light conversion medium or by direct combination (RGB* or RYGB†) of individual spectral peak emitters, although the latter is impacted by an appreciable loss of efficiency within the green-yellow region of the visible spectrum when applying current technology.¹⁹

LEDs are capable of being dimmed over a wide operational range with minimal losses in efficacy when compared to conventional lighting, making LEDs a prime

* Red, green and blue.

† Red, yellow, green and blue. Alternately: red, amber, green and blue (RAGB).

candidate for mixed illumination environments where luminance levels must be balanced between multiple illumination sources. Pulse width modulation (PWM) and amplitude modulation (AM) are the two LED dimming strategies most commonly used, however more complex hybrid,²⁰ multiphase²¹ and multilevel²² techniques are available, each with their own merits toward colorimetric preservation, reduction of driver harmonics and energy efficiency. For dynamic LED dimming applications, PWM is favored since this driving strategy minimizes shifts in colorimetric parameters compared with those of AM.²³

Lamps have been discussed in the literature, which permit the relative intensity of three or more differently colored LEDs to dynamically adjust the chromaticity of the white light produced by the lamp.²⁴ Although such lamps can accurately reproduce the color of daylight throughout the day, because the three or more different light sources must be independently controlled, the electronics and algorithms required to achieve a color match can become complex (such as those used to optimize CRI scores²⁵) and potentially costly to implement. Alternately, such systems can require the user to adjust the color and luminance of the lamp by manipulating several controls which operate in a non-intuitive manner.

The goal of this paper is to demonstrate a simpler lamp concept which is capable of producing a colorimetric match to standard daylight over a typical CCT range. This lamp concept uses only two light sources which are then blended together to match a desired CCT and approximates standard daylight spectra at intermediate CCT values. Previous research²⁶ demonstrated a lamp having independently-controlled cyan and yellow-white emitters that could be controlled to create a wide range of correlated color

temperatures. Unfortunately, the lamp did not match the spectrum of daylight. The authors have recently discussed a concept lamp capable of matching the color temperature and standard spectra of daylight over a broad range of color temperatures.²⁷ As proposed, this concept lamp permits the ratio between two independently-controlled white emitters, one having a high and one a low CCT point, to move the lamp's chromaticity point along a straight line between the two points on or near the blackbody locus as illustrated in Figure 1.

This approach reduces computational effort for solutions between the two selected CCT end points. Since the two respective light sources only need to be dimmed proportionally to each other to approximate daylight spectra across the intermediate range between the two sources, individual source intensities are not calculated, eliminating the need to compute individual dimming solutions for all desired daylight CCT points. As a result, a single, intuitive control (user adjustment or two element sensor) can be provided to adjust the perceived color of the lamp's output.

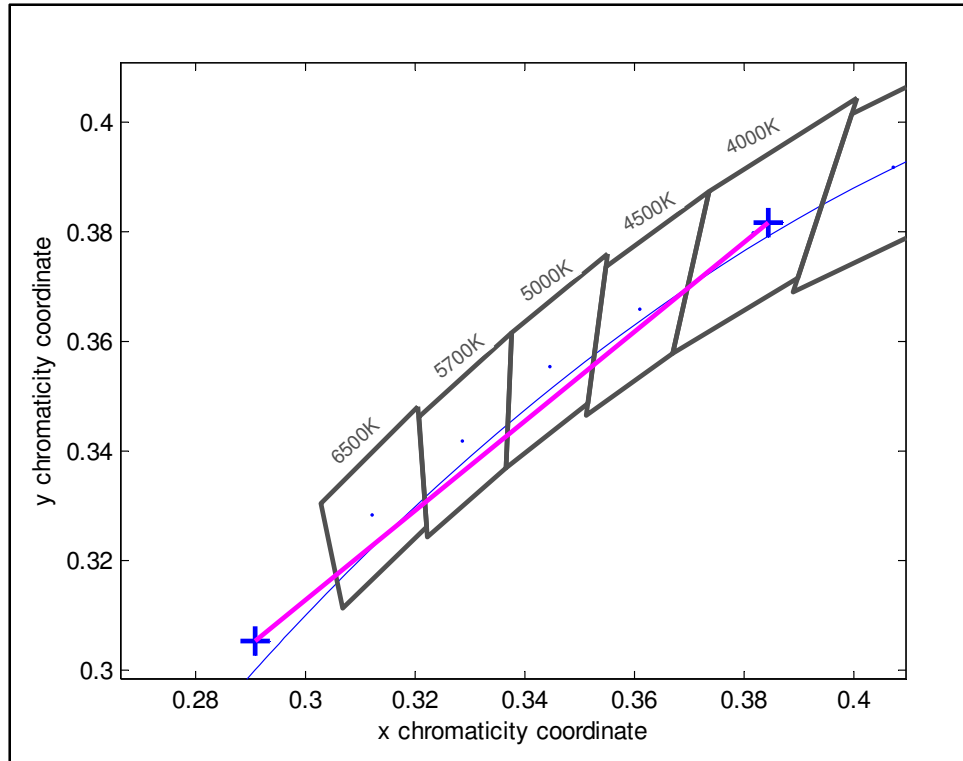

Figure 1. Blending concept illustration showing two selected end point sources (heavy cross) and the available CCT solutions (heavy straight line). Standard ANSI* CCT boxes and blackbody locus are shown for reference.

Method

A prototype lamp was designed to demonstrate the standard daylight match-by-blending concept. This prototype employs commercial off-the-shelf LEDs, current drivers, heat sinks, and power supply, along with custom TTL/CMOS IC logic circuitry

* American National Standards Institute (ANSI_NEMA_ANSI C78.377-2008)

capable of accepting a dimming solution from a computer model for the creation of two white light sources. From earlier work²⁷ it was determined that LEDs were not readily available to demonstrate a high quality match to standard daylight spectra. However, the prototype was demonstrated to create a reasonable match to standard daylight and permit the validation of a colorimetric model for designing such a lamp.

Prototype design

The prototype lamp consists of four major component groups: power supply, high brightness LEDs, LED drivers and control logic. Connectivity is straightforward (Figure 2) whereby the regulated power supply provides DC power at 5 volts (V) and 24 V to the control logic and constant current LED drivers, respectively. The LED drivers accept PWM and enable signals from the control logic to drive the respective LEDs, which are mounted in a custom lamp head on heat sinks in a circular pattern.

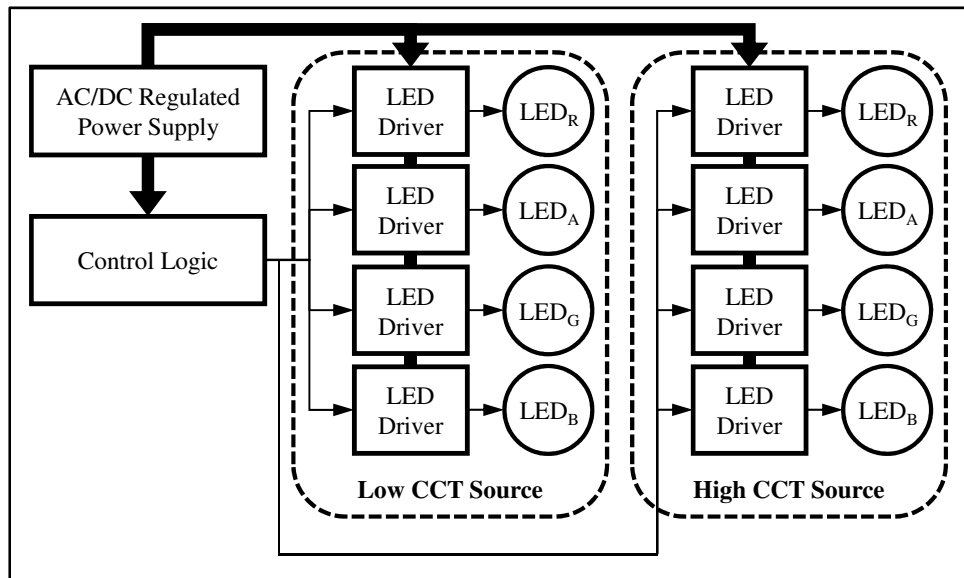

Figure 2. Prototype standard daylight matching LED lamp system topology.

Implementation using novel dual PWM scheme. Each of the two independently-controlled white emitter sources are comprised of a string of four commercially-available high-brightness LEDs (RAGB) with spectral distributions and center wavelengths at 464, 512, 598 and 634 nm as shown in Figure 3. As shown the amplitudes of the various LEDs differ, with the green and yellow LEDs outputting only a fraction of the radiant power of the blue and red LEDs at their peak recommended intensity. Creation of each white light source requires the properly weighted combination of each of the four LED colors within each string of LEDs. After dimming each LED within a string to achieve the proper CCT and chromaticity coordinates for each light source, the two strings (A & B) must be blended together without affecting the relative on-time of the LEDs within each string to produce intermediate CCTs. To minimize color shifts due to dimming, PWM was selected as the preferred control method for the lamp. Implementation of the lamp concept, which had to allow for prototype adjustment and testing, required the development of a novel PWM scheme, referred to by the term “dual-PWM” throughout the remainder of this paper.

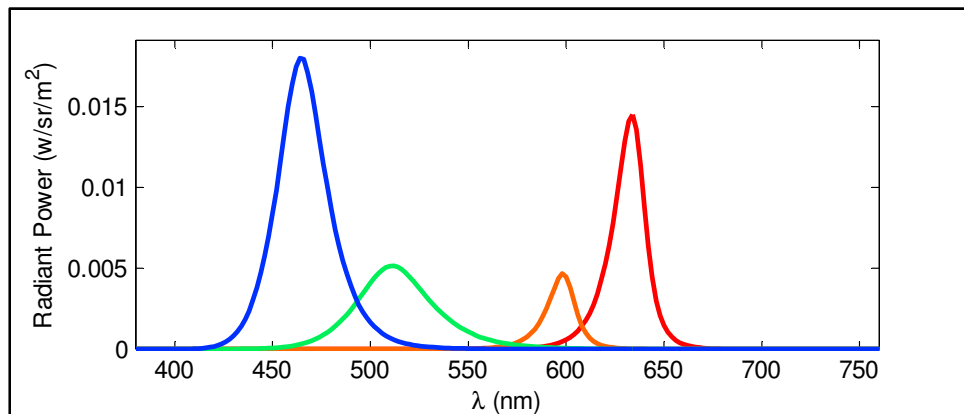

Figure 3. Radiant power of selected LEDs over the visible spectrum.

Typical PWM dimming control of LEDs is accomplished by varying the duty cycle of the clock signal sent to the driver or LED directly. The duty cycle is often controlled by varying a binary bit pattern over a predetermined bit length to achieve a repeating pattern at some effective frequency as to avoid any human perception of flickering. In this case, a binary PWM signal is used to construct the required spectral distribution for the given source with the power level of each of the four LEDs being controlled by their on-time. The prototype uses 4-bits per LED for intensity, permitting 16 dimming levels. Additionally, each LED has an enable signal allowing the LED to be disabled. The two sources are then blended together using another underlying layer of PWM, this time through analog control, which varies the master clock's duty cycle. One source operates from the standard clock signal (CLK) and the other from an inverted clock signal (!CLK) such that the duty cycle of each clock signal proportionally dims each source's binary PWM-constructed spectrum. The dual-PWM signal sent to each LED driver therefore contains a series of clock pulses so long as a running count is less than or equal to that specific LED's desired dimming level. Figure 4 illustrates this approach.

The master clock signal, at a 50% duty cycle (50% blend of sources), is shown in the top trace of Figure 4(a), followed by the inverse clock signal. A free running, recycling counter signal counts on the rising edge of the clock. The bottom four traces of Figure 4(a) depict the dual PWM signal sent to two LEDs in string A (driven at dimming level [0010] and [1000]) and two LEDs in string B (driven at dimming level [0110] and [1101]). Figure 4(b) depicts a 20% duty cycle (20% blend of string A with 80% of string B) over two full counter cycles and Figure 4(c) shows a 99% duty cycle (99% of string A

with 1% of string B) over two cycles of the counter whereby effectively all the power goes to string A.

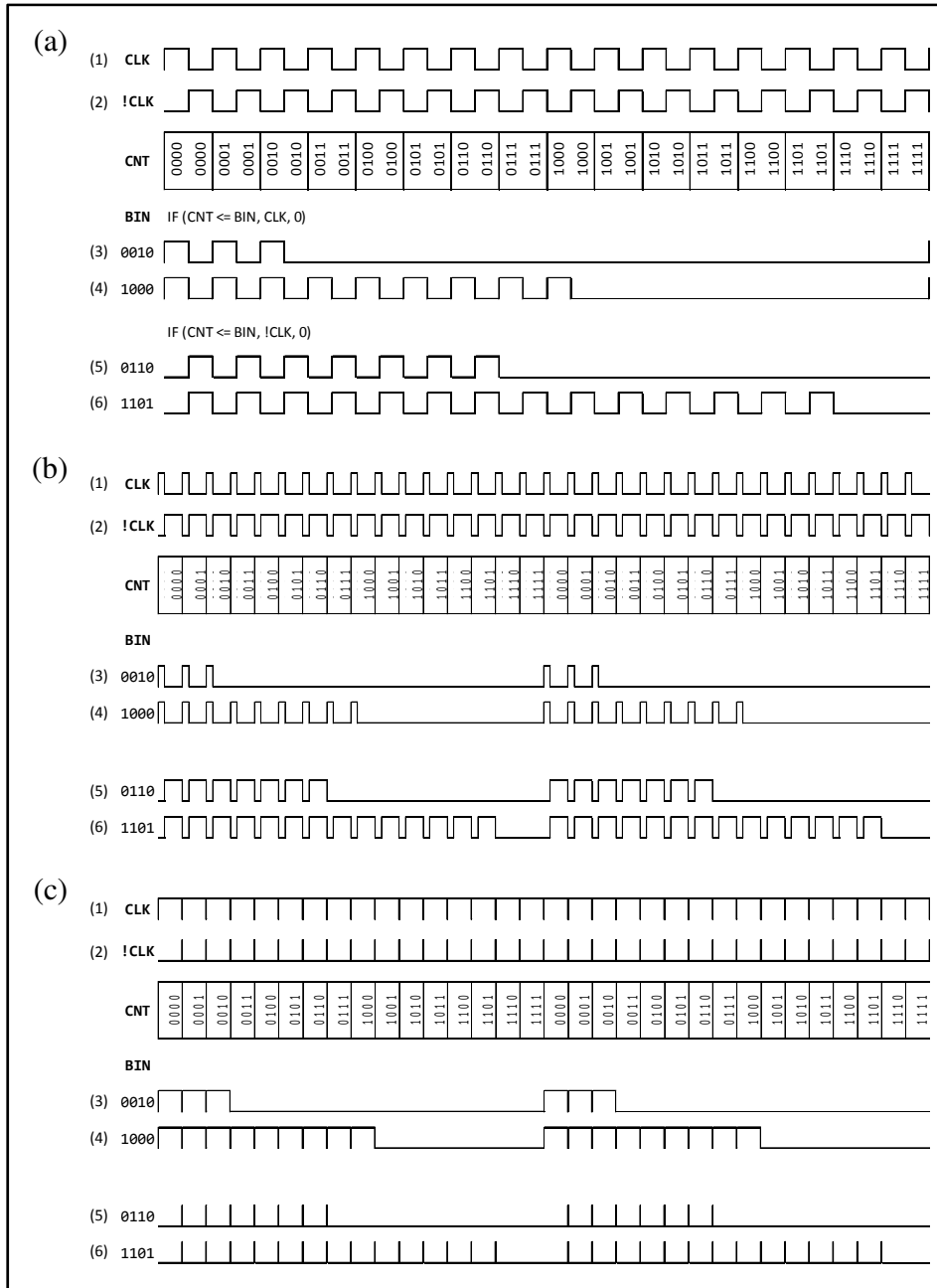

Figure 4. Dual-PWM scheme. (a) A 50% duty cycle and the resulting dual-PWM signals sent to two LEDs in string A (traces 3 & 4) and two LEDs in string B (traces 5 & 6). (b) Depicts a 20% duty cycle over two full counter cycles. (c) Shows a 99% duty cycle over two full cycles of the counter whereby string A LEDs are on at effectively 100% of their specified dimming level.

Control logic was constructed which is capable of accepting a given binary dimming solution set, provided by computer modeling, for each string of four LEDs to permit the light produced by each string of four LEDs to match a desired chromaticity point and CCT. The ability to manually blend light from the two sources by adjustment of one control is also included through the integration of a precision potentiometer (R_1) which provides 1000 repeatable, potential blending levels to achieve an intermediate CCT. When R_1 is set to the lowest value, [000], the clock duty cycle is at its maximum level as is the luminance of source A while source B is at its minimum; with R_1 at the highest value, [999], the clock duty cycle and luminance of source A are at their minimum and source B is at its maximum. At any other R_1 value, the luminance of source A and source B are blended proportionally. For example, at a value of [300] the contribution of source A is approximately 70% and source B is 30%. To eliminate the possibility of visible LED flicker when a given LED is driven at the minimum dimming level and duty cycle the dual-PWM signals are sent to the respective constant current drivers at a nominal clock frequency of 9.6 kHz. Since the implementation scheme uses a 4-bit binary counter, the effective dimming cycle frequency is approximately 600 Hz, well above the human critical flicker frequency. The control logic was implemented, as

shown in Figure 5, on an electronics breadboard using standard TTL and CMOS dual inline package integrated circuits.

Each of the eight LEDs is powered by separate constant current buck regulators. A National Semiconductor LM3404 evaluation board* was selected for simplicity purposes since two of the four LEDs required 1 A of drive current and the evaluation boards would require no modification. Additionally, the LM3404 boards are capable of accepting PWM and enabling signals from external control logic.

* <http://www.national.com/an/AN/AN-1545.pdf>

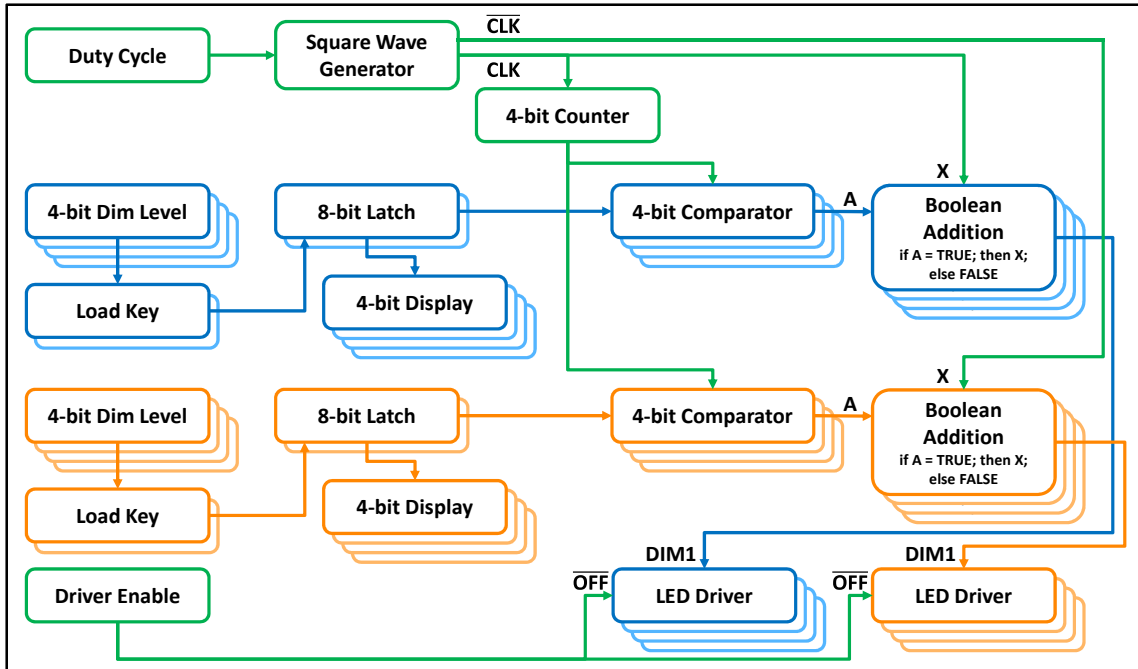

Figure 5. Prototype control logic diagram. Computer model binary dimming solution values are loaded and latched for comparison to a running counter, the result is added to the duty cycle adjusted clock signals to produce a dual-PWM signal for controlling the respective LED drivers.

Advanced implementation using novel time-shared dual PWM scheme. The above control and driving scheme is simple and permits analysis and troubleshooting of the prototype lamp as different sources are created and evaluated. Further, it provides an effective illustration of the lamp concept. To reduce the number of LEDs required for implementation of the lamp concept from eight to four and to reduce blending deviations resulting from LED binning variations the authors developed a novel time-shared dual-PWM scheme (Figure 6). Building on the framework of dual-PWM, the two modulation signals sent to a particular color LED, one in source A and one in source B, can be combined through a simple additive Boolean operation to produce a single signal which incorporates the dimming level information for both source solutions as well as blending information provided by adjustment of the duty cycle. This process is particularly easy

since the signals are already half a cycle out of phase, effectively allowing four LEDs to emit light at a level and proportion necessary to produce the required spectra for chromaticity coordinates to follow a straight line between sources A and B. Alternately, the number of LEDs can be increased by any multiple of four, thereby increasing the luminance of the lamp and minimizing the effects of center wavelength and spectral distribution variations within any particular color of LED. This method can also be expanded to include additional LEDs of different colors to increase the lamps rendering quality. Effectively, this approach permits the light from the two sources to be integrated temporally rather than spatially, yet supports the general concept of providing two effective sources where the intensity of the two sources is varied to control the color temperature of the light produced by the lamp.

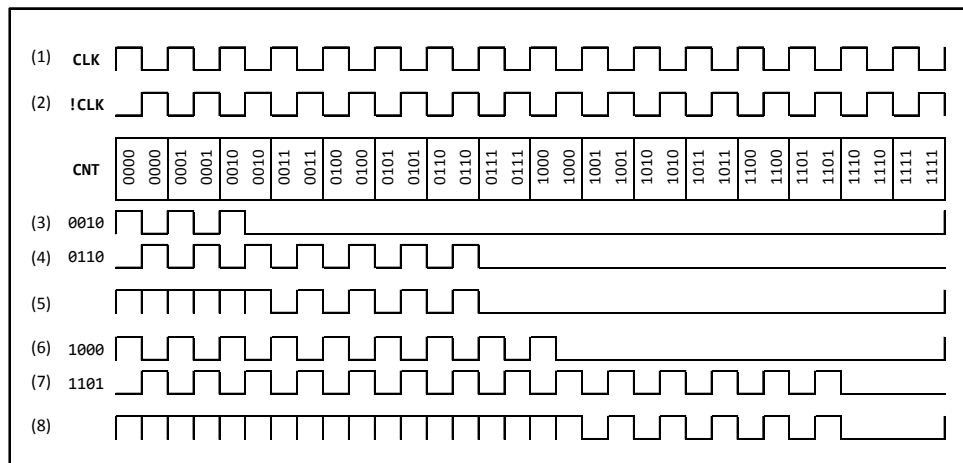

Figure 6. Time-shared dual-PWM scheme. Following from the example in Figure 4, the first dual-PWM signals (traces three and four) for LEDs from strings A and B, [0010] and [0110], assumed to be the same color, are logically combined to produce the single time-shared dual-PWM signal (shown as trace five) for that particular color LED. Similarly, the second signals from strings A and B, [1000] and [1101], are combined, resulting in the bottom trace.

Computer model

Computer modeling is used to determine a binary dimming solution for each of the four LEDs, in each of the two strings, to achieve an acceptably-close colorimetric match to standard daylight spectra at both a low and a high CCT point. The model, constructed in Matlab[®], accepts user inputs for LED spectra, bounded low and high CCT targets, and minimally acceptable CQS and CRI scores.

Examination of the lamp's response spectra under isolated dimming conditions revealed that most noticeably the peak amplitude of each LED, when subjected to dual-PWM did not follow a linear trend over the full dimming range. Since the objective was to demonstrate the concept of standard daylight matching by blending fixed CCT sources comprised of either inorganic or organic LEDs, precise computer modeling of, in this case inorganic, LED responses for solution generation was not pursued. The lamp's measured response was used for model computations. Spectra input consisted of 128 separate spectra containing measured spectral intensity values at a spacing of 2 nm from 380 nm to 760 nm. These 128 spectra included a spectral intensity curve for each of the eight LEDs comprising the two sources over the 16 available dimming levels. Measurements were taken while the LEDs were driven by the control logic. The disabled state was amended by the model to provide a total of 17 spectra for each LED for processing by the model.

The model executes an iterative, exhaustive search method for the low CCT source solution. All possible 4-LED, 4-bit, dimming combinations are searched and those with a CCT within the specified bounds and CQS or CRI scores above the specified

minimum thresholds are retained for additional processing. The dimming solution with the highest CRI score, as computed against a target-matched daylight spectrum, is selected as optimal. This process was then repeated for the high CCT target. The model returns a four element dimming solution and CRI score (using a solution-matched standard daylight spectra) for both target CCT points along with predicted CQS scores for 100 points, representing 100 CCTs along the straight line connecting the two sources.

Source selection and measurement configuration

Source CCT targets of 4000 K and 8000 K were selected, since a large portion of typical daylight would fall within this range, and bounded at 3800 – 4300 K and 7800 – 8500 K, respectively. Bounding values are selected solely for the purpose of reducing the number of additional computations performed for combined spectral data falling outside the general range of the source location. Since the available LEDs have less than ideal center wavelengths, the CQS and CRI minimum scores were set at 55 and 40, respectively, for both sources, to capture enough chromaticity points for additional analysis. Spectral data were collected from the lamp output using a Photo Research SpectraDuo[®] PR680L spectroradiometer and SRS-3 diffuse reflectance standard over eleven blending ratios by setting R_1 to [000, 100, 200, 300, 400, 500, 600, 700, 800, 900, and 999]. Measurements were taken in an improvised dark room where the dark light level was effectively 0 lux at the surface of the SRS-3; below the detectable threshold of both the PR680L and a Konica Minolta[®] T-10 illuminance meter. The SRS-3 was located 15 inches (in) (38 cm) below the LED array. The PR680L was in a luminance and radiance configuration, used a 2°-observer, and averaged five samples for each reading

for all measurements. A stationary tripod held the PR680L objective lens at a distance of 25 in (64 cm) from the surface of the SRS-3 at an incline of 36 degrees.

Results

Model blending solution

The computer model returned the solution set shown in Table 1 and generated the predicted combined spectra shown in Figure 7 for the low and high CCT source points. This dimming solution was loaded into the prototype’s control logic for measurement and evaluation.

Table 1. Dimming solution set produced by computer model. Values represent scaling factor applied relative to each LED’s maximum measured power spectra.

Source	CCT	CRI	Red	Amber	Green	Blue
Low	3934	62	0.1875 [0010]	0.6875 [1010]	0.4375 [0110]	0.0625 [0000]
High	8329	59	0.1875 [0010]	1.0000 [1111]	0.9375 [1110]	0.2500 [0011]

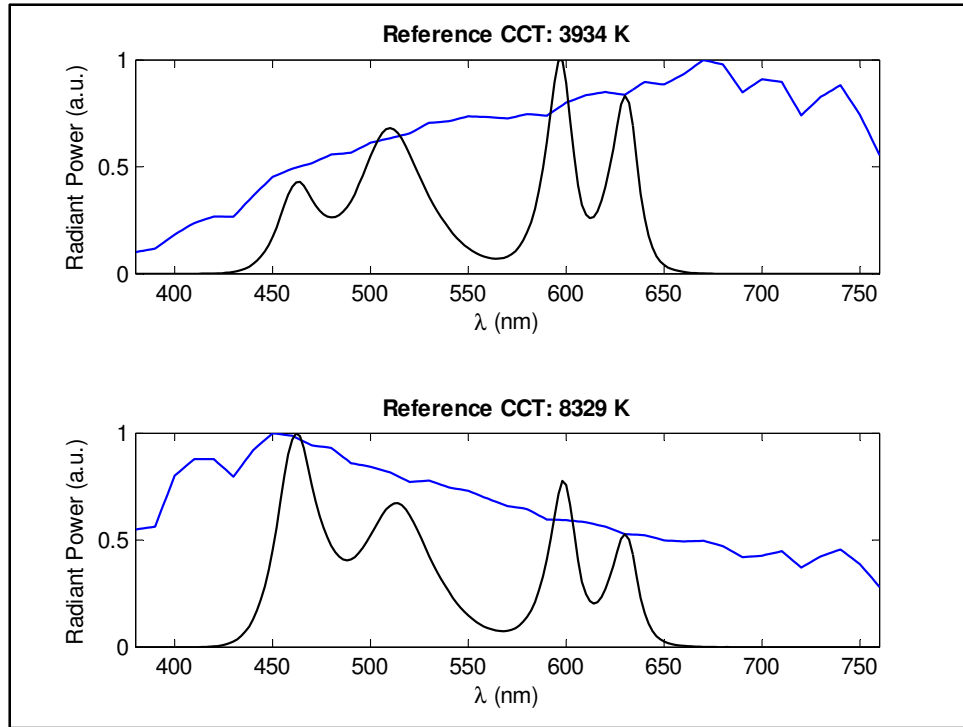

Figure 7. Model-generated low CCT (top) and high CCT (bottom) combined LED spectra from weighted individual LED spectra and corresponding reference standard daylight spectra.

Prototype output

The prototype's response with the solution set of Table 1 is shown in Figure 8. The measured data shown in Figure 8, 9, and 10 are the arithmetic mean values of three separate, repeated measurements of the prototype lamp's output. The blending concept presented by the authors is supported by the results obtained from the lamp. The blended points, depicted as squares in Figure 8, generally follow the straight-line blending trend predicted by the model, which is represented by the straight line connecting the two endpoints. The mid-blending point, at which both sources are contributing 50% of their maximum output, dips noticeably below the target blending line around a CCT of 5500 K, however the lamp's chromaticity coordinates remained within the standard ANSI

color temperature boxes for solid-state lighting. Additionally, points on the warm side of the midpoint fell below the target line, whereas points on the cool side fell above the target line. The lamp's output also demonstrated unequal steps in CCT between blended points; most notably between the extreme endpoints (source points) and the first blended step. Discounting the extreme ends of the range, the overall trend revealed larger steps in CCT as blending moved toward the high CCT source. A simple regression ($R^2 = 0.997$) shows that a desired CCT is obtained, over the designed minimum and maximum range, by adjusting the value of R_1 as shown in Equation 1.

$$R_1 = -3 \times 10^{-5} \cdot CCT^2 + 5.9 \times 10^{-1} \cdot CCT - 1.9 \times 10^3 \quad (1)$$

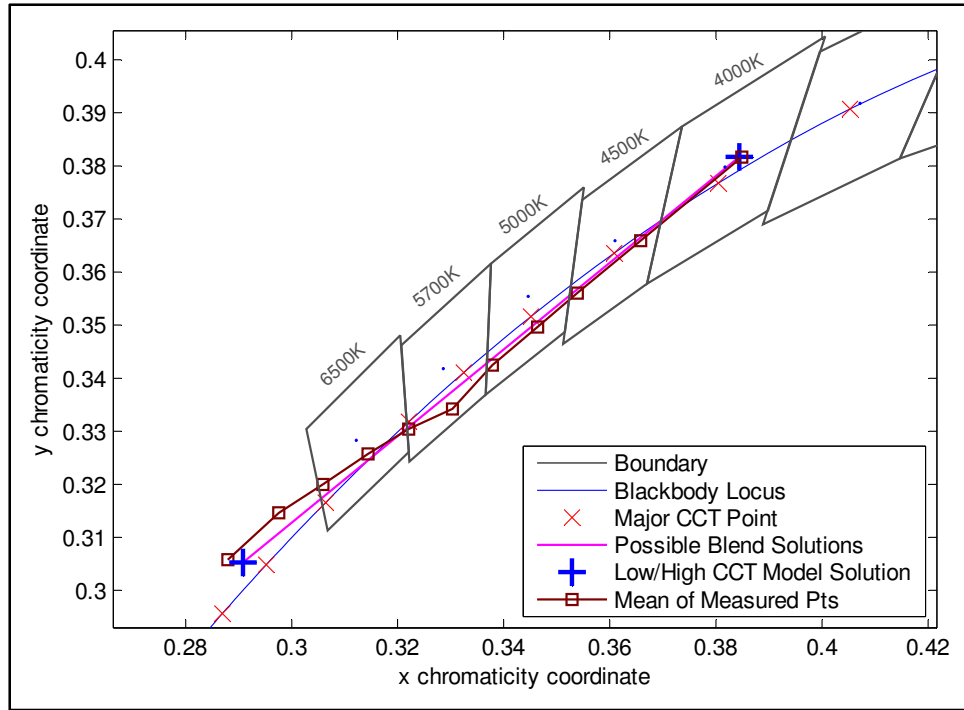

Figure 8. Lamp response measured over 11 blending steps. Blended illuminant chromaticity coordinates shown by squares. Model's possible blended solutions indicated by straight line between model's solution sources (cross).

As discussed earlier, a CCT match alone does not adequately specify the performance of the lamp since a colorimetric match to standard daylight is desired. The prototype's ability to provide a colorimetric match to daylight is evaluated using the CQS scoring method.¹⁰ The measured average CQS score of the lamp's output is shown in Figure 9 along with the model's predicted scores over the design range.

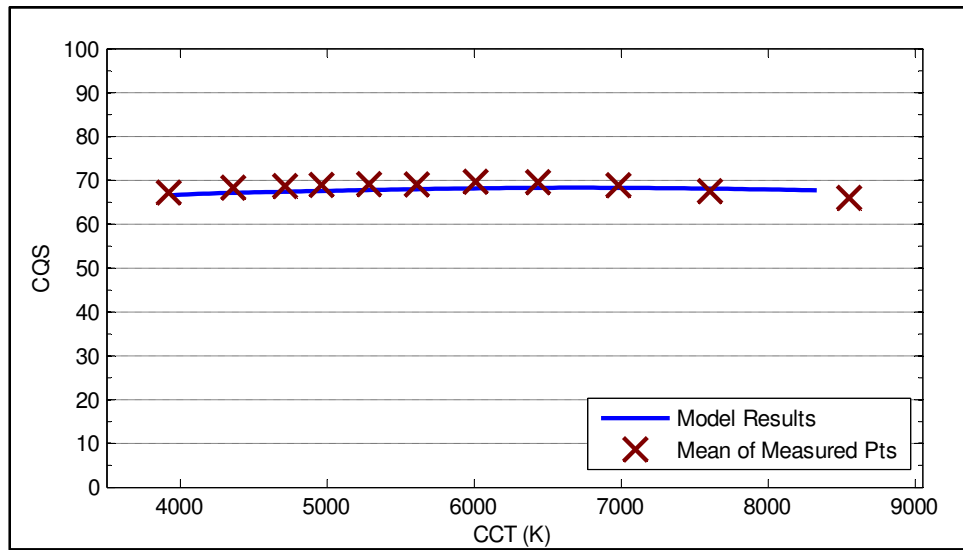

Figure 9. CQS score vs. CCT for measured blending points (X) and model prediction (solid line).

With the exception of the two highest measured CCT points, the lamp spectra returned a CQS score which was relatively constant and slightly greater than the model prediction. While a CQS score in the upper 60's is not ideal, nor practical for critical lighting applications, it was found to be among the best available from blending the output of the four selected commercially-available LEDs.

Figure 10 shows that the lamp's overall luminance levels follow a linearly increasing trend within the 10-90% blending range. No effort was made to force the model toward a solution containing sources with equal individual luminance levels as well as maximized colorimetric matches. The greater luminance value of the high CCT source was to be expected since the model's solution set indicated that the amber, green, and blue LEDs must be driven at a greater power level than those of the low CCT source.

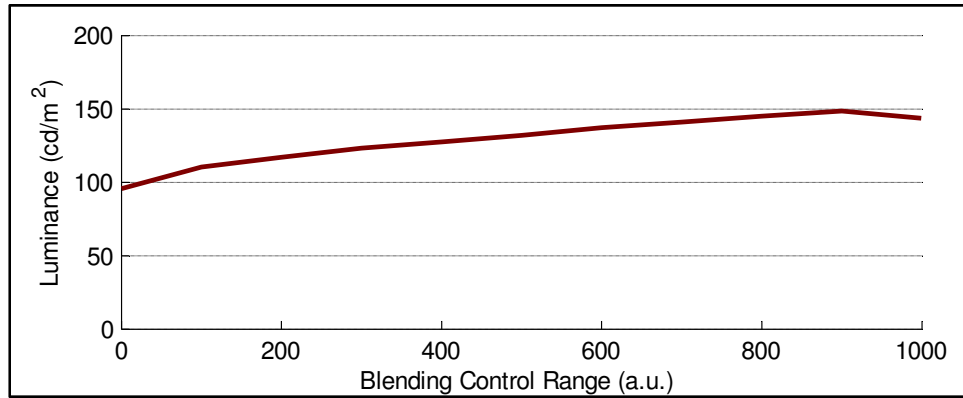

Figure 10. Overall lamp luminance as a function of the blending ratio between low and high CCT sources. Values along the x-axis directly correspond to R_1 values. Source A is at its maximum when $R_1 = [000]$.

Conclusions

A concept for a simplified approach to constructing a lamp with adjustable CCT was discussed and demonstrated through a prototype LED lamp. This prototype demonstrated that daylight spectra approximation is possible by blending two fixed-CCT sources without the need for ongoing complex calculations when the lamp is employed and that the selection of desired CCT points is easy and repeatable. Creation of white light sources is not restricted to the use of inorganic LEDs as demonstrated in the prototype and the concept is fully intended to be applied toward organic LEDs or other single-emitter white light sources. Two novel dimming schemes were introduced which permit blending illumination sources to produce light at intermediate CCTs through changes to a single resistor value. Additionally, the resulting blended points were demonstrated to have color quality scores equal to or higher than the unblended high and low CCT sources.

Future research will include further development of the drive method to permit luminance as well as CCT adjustment and to develop individual white light sources having spectra that represent standard daylight and that can be blended to approximate the spectra of standard daylight at intermediate CCTs as illustrated through this prototype.

Acknowledgments

The authors would like to acknowledge the Air Force Civil Engineer Support Agency (AFCESA) for sponsoring the current project.

Funding

Funding for this research was provided through a new faculty research grant from the faculty research council of the Air Force Institute of Technology.

Conflict of Interest Statement

The Authors declare that there is no conflict of interest.

Disclaimer

The views expressed in this paper are those of the authors and do not reflect the official policy or position of the United States Air Force, Department of Defense, or the United States Government. This material is declared a work of the United States Government and is not subject to copyright protection in the United States.

References

1. ASHRAE. *Advanced energy design guide for small office buildings, Achieving 30% energy savings over ANSI/ASHRAE/IESNA standard 90.1-1999*. Atlanta, GA: ASHRAE, 2004.
2. Mayhoub MS and Carter DJ. Towards hybrid lighting systems: A review. *Light. Res. Technol.* 2010; 42(1): 51-71.
3. Hernández-Andrés J, Lee RL Jr and Romero J, Calculating correlated color temperatures across the entire gamut of daylight and skylight chromaticities. *Appl. Opt.* 1999; 38(27): 5703-5709.
4. Hernández-Andrés J, et al. Color and spectral analysis of daylight in southern Europe. *J. Opt. Soc. Am. A* 2001; 18(6): 1325-1335.
5. Ashdown I. Chromaticity and color temperature for architectural lighting. In: *Proc. SPIE, Solid State Lighting II*, 2002, Vol. 4776, pp.51-60.
6. Veitch JA, et al. Office lighting appraisal, performance, and well-being: a linked mechanisms map. In: *Proc. of the CIE 26th Session*, Beijing, 4 July – 11 July 2007, CIE178:2007, Vol. 1, pp.D3-61 – D3-64. Vienna, Austria: Commission Internationale de l'Eclairage.
7. Fairchild MD and Reniff L. Time course of chromatic adaptation for color-appearance judgments. *J. Opt. Soc. Am. A* 1995; 12(5): 824-833.
8. Newsham GR, et al. Individual control of electric lighting in a daylit space. *Light. Res. Technol.* 2008; 40(1): 25-41.
9. Fontoynt M. Perceived performance of daylighting systems: lighting efficacy and agreeableness. *Sol. Energy* 2002; 73(2): 83-94.
10. Davis W and Ohno Y. Color quality scale. *Opt. Eng.* 2010; 49: 033602.
11. Guo X and Houser KW. A review of colour rendering indices and their application to commercial light sources. *Light. Res. Technol.* 2004; 36(3): 183-199.
12. Zukauskas A, et al. Statistical approach to color quality of solid-state lamps. *IEEE J. Sel. Top. Quantum Electron.* 2009; 15(4): 1189-1198.
13. Kuo CP, et al. High performance AlGaInP visible light-emitting diodes. *Appl. Phys. Lett.* 1990; 57(27): 2937-2939.
14. Tang CW and VanSlyke SA. Organic electroluminescent diodes. *Appl. Phys. Lett.* 1987; 51(12): 913-915.

15. Lenk R and Lenk C. *Practical Lighting Design with LEDs*. Piscataway, NJ: Wiley-IEEE Press, 2011.
16. Dabbousi BO, et al. (CdSe)ZnS core-shell quantum dots: synthesis and characterization of a size series of highly luminescent nanocrystallites. *J. Phys. Chem. B* 1997; 101(46): 9463-9475.
17. Nizamoglu S, et al. Dual-color emitting quantum-dot-quantum-well CdSe-ZnS heteronanocrystals hybridized on InGaN/GaN light emitting diodes for high-quality white light generation. *Appl. Phys. Lett.* 2008; 92: 113110.
18. Zou J, et al. High-efficiency and good color quality white light-emitting devices based on polymer blend. *Org. Electron.* 2009; 10(5): 843-848.
19. Crawford MH. LEDs for solid-state lighting: performance challenges and recent advances. *IEEE J. Sel. Top. Quantum Electron.* 2009; 15(4): 1028-1040.
20. Bęczkowski S and Munk-Nielsen S. Led spectral and power characteristics under hybrid PWM/AM dimming strategy. In: *Proc. IEEE Energy Conversion Congress and Exposition (ECCE), 2010*, pp.731-735.
21. Doshi M and Zane R. Control of solid-state lamps using a multiphase pulsewidth modulation technique. *IEEE Trans. Power Electron.* 2010; 25(7): 1894-1904.
22. Tan SC. Mitigating energy wastage of light-emitting diodes using discretised multilevel pulsation. *Electron. Lett* 2009; 45(10): 522-524.
23. Pousset N, Rougié B and Razet A. Impact of current supply on LED colour. *Light. Res. Technol.* 2010; 42(4): 371-383.
24. Aldrich M. Dynamic Solid State Lighting. MS Thesis, Massachusetts Institute of Technology, USA, 2010.
25. Lin KC. Approach for optimization of the color rendering index of light mixtures. *J. Opt. Soc. Am. A* 2010; 27(7): 1510-1520.
26. Okumura Y. *Color temperature-regulable LED light*. Patent US 2004/0264193 A1, USA, 2004.
27. Miller ME and Gilman JM. Daylight-matched lighting for mixed illumination environments. In: *Proc. of the IES of North America Annual Conf.*, Austin, TX, 31 October 2011 – 1 November 2011. New York: Illuminating Engineering Society of North America.

Author biographies

Jacob M. Gilman is a Captain in the United States Air Force and completing his Master of Science at the Air Force Institute of Technology (AFIT). His research focus includes daylight approximation through blending LED sources and driving schemes for simple LED lamp implementation and operation for the purpose of supplementing natural daylight within facility spaces. Upon degree completion, Capt Gilman will continue his more than nine years of service within the Air Force Civil Engineer career field. Prior to his selection to attend AFIT, Capt Gilman held positions at both squadron and major command levels of responsibility and completed three combat tours within Iraq and Afghanistan. Additionally he is a member of the Society of American Military Engineers (SAME) and Sigma Iota Epsilon (SIE).

Michael E. Miller, PhD is an Assistant Professor of Human Systems Integration at the Air Force Institute of Technology. His research interests include human systems integration, modeling and measurement of human performance and human interface design, particularly human-display integration. Prior to joining AFIT, Dr. Miller spent more than 15 years with Eastman Kodak Company as a systems and human factors engineer. Dr. Miller holds over 60 US Patents in digital imaging and OLED systems. He is a senior member of SID, a member of the Human Factors and Ergonomics Society, a senior member of the IIE, and a member of INCOSE.

Dr Michael R. Grimaila (BS, MS, PhD, Texas A&M University) is an Associate Professor of Systems Engineering and a member of the Center for Cyberspace Research (CCR) at the Air Force Institute of Technology (AFIT), Wright-Patterson AFB, OH USA. Dr Grimaila's research interests include mission assurance, network management

and security, quantum information warfare, and systems engineering. He is a CISM, CISSP, a member of the ACM, a Senior Member of the IEEE, and an ISSA Fellow.

IV. Article 3 – Daylight-Matched Lighting for Mixed Illumination Environments

Daylight-Matched Lighting for Mixed Illumination Environments

Michael E. Miller, PhD and Jacob Gilman

Air Force Institute of Technology

Wright Patterson Air Force Base, OH

Email: Michael.Miller@AFIT.edu

Abstract

To improve the efficiency of illumination, significant efforts are underway to adopt LED lamps with higher efficacy and to effectively integrate natural illumination with active dimming of electric lighting. While each of these trends has the ability to significantly reduce power consumption, the color and spectral properties of typical LED lamps and natural light will not be consistent during a significant portion of the day. This paper proposes and analyzes spectral properties of a relatively simple lamp concept, which addresses this issue. The analysis indicates that it is possible to form a lamp having only two independently controllable groups of narrowband emitters which is capable of producing light that produces a nearly colorimetric match to daylight which varies in color temperature from 5000 to 10000K.

Background

Recently, published building construction guidelines (Jarnagin et al., 2004) have placed an increased emphasis on sustainability. With respect to illumination, these guidelines suggest building designs with an increased reliance on natural light to reduce

the amount of electric light and the power required to create this light. However, it will often be impractical to rely entirely on natural illumination, requiring a mixture of natural and electric illumination to achieve the desired illumination levels within most office environments.

Unlike electric illumination, which typically has a constant color, the color of light provided by natural illumination can vary throughout the day. One commonly used metric to describe this change in color is the correlated color temperature (CCT), which can vary from 2000K at sunrise through 5000K for direct daylight at noon and can exceed 10000K in overcast conditions. In our natural environment, this color change is not noticeable as only natural light is present and our visual system adapts to this change in the color of the light.

In mixed illumination environments, natural and electric illumination will be simultaneously present and each source can illuminate neighboring areas of the environment. As the color of electric illumination is typically constant and the color of the natural illumination changes during the day, multiple colors of illumination will be present in these mixed illumination environments. Our visual system will, therefore, adapt to a color somewhere between the colors of the two illumination sources. As a result, the difference in the color of illumination from the two sources can be evident and potentially undesirable.

Electric lamps that can mimic changes in daylight spectra have other potential benefits. Ganglion cells in the human retina respond to a limited range of visible light wavelengths to modulate the retinal input to the circadian pacemaker affecting sleep cycles (Berson et al., 2002; Figueiro, et al., 2008). Therefore, lamps that modulate their

spectra in concert with or to mimic natural daylight could influence human biorhythms, potentially addressing issues such as seasonal affective disorder (Johansson, 2003) or improving sleep or productivity of shift workers through improved modulation of circadian rhythms. It has further been hypothesized that the CCT of light can influence mood, human activation, and cognitive performance, although experimental evidence of these effects is inconclusive (Veitch and McColl, 2001).

Another trend in lighting design is the adoption of new technologies, including inorganic and organic light-emitting diodes (Kuo et al., 1990; Tang & VanSlyke, 1987). This technology has the potential to provide high energy efficacy compared with tungsten and fluorescent lamps (Lenk & Lenk, 2011). Additionally, these technologies provide narrowband emission, the center frequencies of which can be tuned or combined with other technologies, such as quantum dots (Dabbousi et al., 1997; Nizamoglu 2006; Zou et al., 2009) to create lamps with multiple, frequency-selectable, spectral peaks. Through selective application, the relative emission at each of the narrow emission bands can be controlled to permit the accurate selection of colors.

This paper explores the application of this technology to create a lamp that has an adjustable CCT to mimic changes in the color of natural light. As noted earlier, the CCT is one potential metric of color. Although this metric describes the overall change in color, it provides an approximate description of the color of the light emitted by the lamp and does not describe the perceived colors of objects in an environment that reflect light from the lamp. Other metrics, such as Color Rendering Index (CRI), Color Fidelity Scale (CFS), and Color Quality Scale (CQS) are necessary to achieve this goal (Davis & Ohno, 2010). Therefore it is important that the lamp provide both adjustable color temperature

and permits accurate illumination of the environment with respect to the spectrum of the natural light.

Proposed Lamp Concept

Previous literature discussing lamps that are adjusted to match the color of daylight have used numerous independently-controlled light sources (Aldrich, et al., 2010). Although such lamps can accurately reproduce the color of daylight, because 3 or more different light sources must be independently controlled, the electronics and algorithms required to achieve a color match can become complex, potentially costly to implement and difficult to control.

Our goal was to investigate an alternate method for constructing a lamp having the capability to match the color temperature of natural light under a relatively broad range of daylight conditions. Certain simplifying assumptions were made to facilitate this work. First, it was assumed that the spectrum of daylight can be described using standard daylight spectra for color temperatures greater than 5000K. Secondly, we assumed that the adequacy of the electric light source could be determined by matching the color temperature of the electric lamp to numerous discrete color temperatures of daylight. It was further assumed that the quality of this color match could be determined based upon the Color Fidelity Scale, calculated with reference to the standard daylight spectra across a range of color temperatures.

To simplify the algorithms and control electronics, only two independently-controlled light sources were assumed. It has been shown that the color temperature of a lamp can be varied over a large range using a lamp with only two controlled light sources

(Okumura, 2004). Further, the spectra for these two light sources can be selected to not only match the color temperature but the spectra of the daylight source (Miller, Madden, Cok, & Kane, 2010).

This concept is illustrated in Figure 1. The left panel of Figure 1, shows a 1931 chromaticity diagram with a curve near the Planckian Locus indicating the colors of daylight ranging from 5000K to 10000K according to the assumptions stated earlier. The 5000K and 10000K points are indicated by a pair of circles, the intermediate squares show the locations of the 6000, 7000 and 8000K daylight colors. A line connecting the chromaticity coordinates of the 5000 and 10000K light sources indicates the range of chromaticity coordinates that can be created by combining the light from these two light sources. This line lies near the daylight curve and the color of light produced at the 6000, 7000, and 8000K color temperatures.

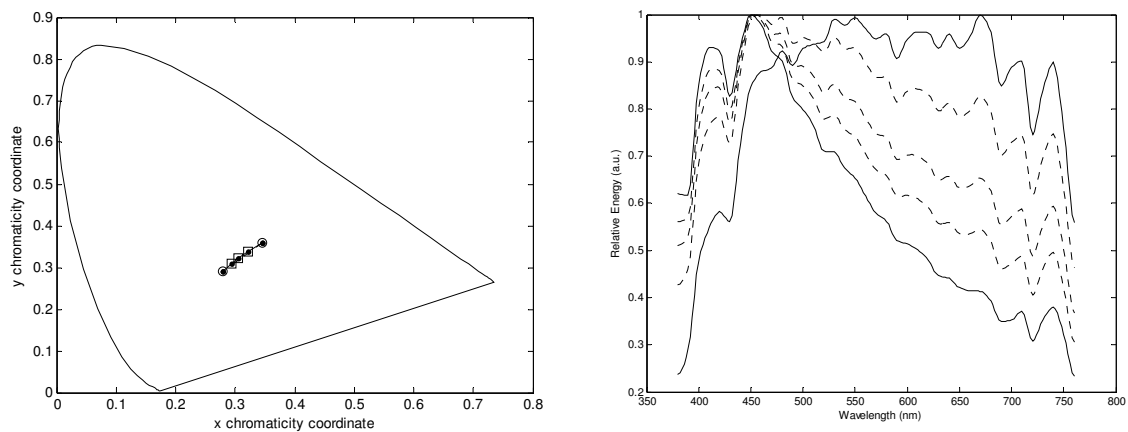

Figure 1. Chromaticity coordinates and spectra for daylight color temperatures of 5000, 6000, 7000, 8000, and 10000K.

The right panel of Figure 1 illustrates a family of five spectral curves for the five color temperatures shown in the chromaticity diagram. The top and bottom spectral curves represent the 5000K and 10000K color temperatures, respectively. The three

intermediate spectral curves are created by mixing the two solid-line spectral curves to achieve the three intermediate color temperatures of 6000, 7000 and 9000K. Although difficult to illustrate in a single plot, the resulting spectral curves provide a very high quality match to the intermediate daylight spectral curves at each wavelength within the visible spectrum.

This observation suggests a method for constructing a lamp having only two independently-controllable light sources which have the potential to match not only the color temperature of different daylight illumination conditions but the spectra of the daylight source over this range of daylight color temperatures. Specifically if a lamp is designed such that:

- 1) the spectrum of a first light source is designed to match the spectrum of daylight at a low color temperature;
- 2) the spectrum of a second light source is designed to match the spectrum of daylight at a high color temperature; and
- 3) the two light sources are incorporated into a single lamp that permits the ratio of light produced by the first light source with respect to the second light source to be varied, the lamp will be able to provide a range of color temperatures and spectra that can match daylight spectra over a range of color temperatures.

Although this approach suggests a possible method for constructing a relatively simple lamp to achieve the desired result, the practicality of such a lamp might depend on

the number of sources (e.g., differently colored LEDs) necessary for incorporation into each light source.

Method

To understand the spectral requirements of the proposed lamp concept, an optimization model was created in MATLAB[®] to explore potential lamp configurations and the validity of this concept. This model permitted the simulation of a light source in which the number of emission peaks having a defined Gaussian shape and a given bandwidth were selected. For this analysis, it was assumed that the emission peaks had either a full width at half maximum amplitude (FWHM) of 30 nm, which is somewhat representative of inorganic LED emission spectra, or 60 nm, which is somewhat representative of OLED emission spectra. The model then optimized the spectral location and amplitude of the spectral peaks to maximize CFS with reference to the selected daylight source. This process was repeated for both a high CCT of 10000K and a low CCT of 5000K. The resulting two spectral curves were assumed as the spectral curves for the first and second light sources as described in the lamp concept. The relative amplitudes of the two spectral curves were then varied to achieve the intermediate CCTs of 6000, 7000, and 8000K and CFS values were calculated as a function of the daylight spectrum at each color temperature. The minimum values were then determined across these color temperatures and served as an overall quality rating for the resulting lamp.

Results

Table 1 shows the CFS values as a function of the number of emission peaks for each spectral bandwidth and the two color temperatures. If a minimum CFS of 85 is desired, 4 and 5 emission peaks will be required for high and low color temperatures, respectively, when the FWHM is 30 nm. When the bandwidth of the spectral peaks is increased to 60 nm, only 3 emission peaks will be required to achieve this goal, regardless of the color temperature. As shown, each of these two color temperatures can be achieved by combining light at multiple emission peaks at a prescribed ratio of output. In this analysis, we then assume that the location and amplitude of the emission peaks are fixed for the low and high color temperature light sources. That is a first light source is defined at the low CCT and a second light source is defined at the high CCT where each light source contains the number of emission peaks at the optimal locations and with the optimal amplitude of emission.

Table 1. CFS values as a function of number of spectral peaks at aim CCTs and Bandwidths.

Number of Peaks	30 nm Bandwidth		60 nm Bandwidth	
	5000K	10000K	5000K	10000K
2	21.3	17.4	65.2	63.0
3	83.5	82.1	95.6	95.0
4	84.3	96.8	98.1	98.4
5	98.0	97.3	99.3	99.5
6	98.4	98.6	99.6	99.4

Table 2 provides the minimum CFS values as a function of the number of spectral peaks for each of the two light sources for the 30 nm bandwidth conditions when the

relative amplitude of the combined two spectra is modulated to obtain light at 6000, 7000, and 8000K. As shown, the concept does appear viable as it is possible to mix the light from a high and a low CCT light source to obtain a lamp with a high CFS for intermediate daylight CCTs. As shown in Table 2, by combining a first low color temperature light source having 4 emission peaks with a second high CCT light source having 3 emission peaks, it is possible to obtain CFS values greater than 85 for the three intermediate CCTs. However, as noted above, it will be necessary to combine 5 emission peaks to obtain a CFS greater than 85 at the low color temperatures and 4 emission peaks to obtain a CFS greater than 85 at the high CCT. As shown in Table 2, the combination of light from the two independently-controllable light sources results in a lamp having a minimum CFS of 88.3 at the intermediate CCTs.

Table 2. CFS values as a function of the number of spectral peaks in the low and high CRI light source when for emission bandwidths of 30 nm.

Number Low CCT Peaks	Number High CCT Peaks				
	2	3	4	5	6
2	18.6	54.9	55.9	54.9	54.8
3	34.0	82.3	83.2	87.1	87.1
4	35.4	88.0	88.3	95.4	95.4
5	35.4	87.9	88.3	95.6	95.6
6	35.2	88.0	88.2	95.8	96.0

Table 3 shows results similar to those shown in Table 2, where the individual spectral peaks have a bandwidth of 60 nm. As shown in this condition, it is possible to obtain a lamp that is capable of achieving a CFS greater than 85 at the intermediate color temperatures when each light source includes only 3 spectral peaks.

Table 3. CFS values as a function of the number of spectral peaks in the low and high CRI light source for emission bandwidths of 60 nm.

Number Low CCT Peaks	Number High CCT Peaks				
	2	3	4	5	6
2	63.7	76.0	76.0	76.1	76.0
3	73.7	94.1	95.2	95.3	95.3
4	73.9	95.2	95.9	95.9	95.9
5	74.0	95.4	96.0	96.0	96.0
6	74.0	95.4	96.0	96.0	96.0

Conclusions

A concept for a lamp consisting of two independently controlled lights has been described that is capable of matching the color temperature and spectral properties of daylight to provide high color fidelity across a relatively broad range of color temperatures. A lamp constructed as described could be controlled in a mixed environment of natural and electric light to provide electric light that has a colorimetric match to the natural light during a large portion of daylight hours. Such a lamp might have other uses in simulating natural lighting in environments with only electric illumination.

This lamp has only two independently controlled lighting elements. As such it might be applied with a sensor which detects the color temperature and amplitude of natural light within an environment and adjusts the amplitude of each lighting element within the lamp to provide a matching color temperature with spectral characteristics that inherently match the standard daylight spectra.

An initial analysis was performed to assess the influence of the number of spectral peaks, corresponding to different colored inorganic LEDs or OLED emitting materials that would be required within each independently controlled lighting element to achieve the desired color characteristics. As the results show, when applying inorganic LEDs having a FWHM bandwidth of 30 nm to form a lamp using the proposed method to achieve a minimum value on a color fidelity scale of 85 at color temperatures of 5000, 6000, 7000, 8000, and 10000K, the lamp would require 5 LEDs in the low CCT lighting element and 4 LEDs in the high CCT lighting element. An OLED device with emitters having a FWHM of 60 nm using the proposed method would require 3 emissive materials in the low CCT lighting element and 3 emissive materials in the high CCT lighting element.

Future research will explore more efficient methods for forming the lamp, establish performance and perceptual advantages of such a lamp and demonstrate an effective embodiment of the concept.

Acknowledgements

The authors would like to acknowledge the Air Force Institute of Technology for sponsoring the current project.

References

- Aldrich, M., Paradiso, J., & Zho, N. (2010). Energy efficient control of polychromatic solid state lighting using a sensor network, *Proceedings of the SPIE*, 7784, 778408.
- Berson D.M., Dunn, F.A, and Takao, M. (2002) Phototransduction by Retinal Ganglion Cells that Set the Circadian Clock, *Science*, 295, 1070-1073.

- Dabbousi, B. O., Rodriguez-Viejo, J., Mikulek, F. V., Heine, J. R., Matoussi, H., Ober, R., et al. (1997). (CdSe) ZnS core-shell quantum dots: Synthesis and characterization of a size series of highly luminescent nanocrystallites. *The Journal of Physical Chemistry B*, 101(46), 9463-9475.
- Davis, W., & Ohno, Y. (2010). Color quality scale. *Optical Engineering*, 49(3), 033602.1-15.
- Figueiro, M.G., Saldo, E., Rea, M.S., Kubarek, K., Cunningham, J. and Rea, M.S. (2008). Developing Architectural Lighting Designs to Improve Sleep in Older Adults, *The Open Sleep Journal*, 1, 40-51.
- Jarnagin, R., Colliver, D., Deringer, J., Edelson, J., Enck, J., lane, M., et al. (2004). Advanced energy design guide for small office buildings No. 2004110374). Atlanta, GA: American Society of Heating, Refrigerating and Air-Conditioning Engineers.
- Johanson C. et al. (2003) Circadian clock-related polymorphisms in seasonal affective disorder and their relevance to diurnal preference. *Neurophychopharmacology*, 28, 734-739.
- Kuo, C. P., Fletcher, R. M., Osentowski, T. D., Lardizabal, M. C., Craford, M. G., & Robbins, V. M. (1990). High performance AlGaInP visible light-emitting diodes. *Applied Physics Letters*, 57(27), 2937-2939.
- Lenk, R., & Lenk, C. (2011). *Practical lighting design with LEDs*. New York: Wiley-IEEE Press.
- Miller, M. E., Madden, T. E., Cok, R. S., & Kane, P. J. (2010). Lamp with adjustable color, US Patent 7,759,854.
- Nizamoglu, S. (2006). White light generation with CdSe/ZnS core-shell nanocrystals and InGaN/GaN light emitting diodes. *Applied Physics Letters* 92(11) , 11310.
- Okumura, Y. (2004). Color temperature-regulable led light, US Patent Application 11/487528.
- Tang, C. W., & VanSlyke, S. A. (1987). Organic electroluminescent diodes. *Applied Physics Letters*, 51(12), 913-915.
- Veitch, J.A. and McColl, S.L. (2001) A critical examination of perceptual and cognitive effects attributed to full-spectrum fluorescent light. *Ergonomics*, vv(3), 255-279.
- Zou, J., Liu, J., Wu, H., Yang, W., Peng, J., & Cao, Y. (2009). High-efficiency and good color quality white light-emitting devices based on polymer blend. *Organic Electronics*, 10(5), 843(6).

V. Article 4 – A Proposed Lamp for Daylight-Matched Illumination

A Proposed Lamp for Daylight-Matched Illumination

Michael E. Miller, Jacob M. Gilman and John M. Colombi

Department of Systems and Engineering Management, Air Force Institute of Technology

Summary

Advances in solid-state lighting enable many user benefits in addition to improved energy efficiency, such as the ability for more flexible color rendering. This paper explores the color rendering requirements for a lamp that permits the selection of color temperature across a significant portion of the daylight locus. The method applies a pair of independently controlled illumination sources that permit the lamp to not only mimic the color temperature of natural environmental lighting, but to mimic the standardized daylight spectral curves.

The analysis indicated that a lamp formed from the pair of independently-controlled light sources, each including at least four 30 nm or three 60 nm bandwidth unique emitters, can provide a lamp adjustment of the correlated color temperature from 4000 to 10,000K while maintaining a Color Fidelity Score of at least 95. However, increasing the number of emitters by at least 1 additional emitter per light source permits the spectrum of the lamp to emit energy over a larger portion of the visible spectrum. Further, when the set of emitters is constrained to be common between the pair of

independently-controlled light sources, at least five 30 nm or three 60 nm emitters are required to provide a lamp which provides a high quality match to the daylight spectrum.

Keywords: Lighting, Color Matching, Daylight, Color Fidelity Score, Color Rendering Index

Introduction

Recently, solid-state lighting sources, including inorganic light-emitting diodes (LED) and organic light-emitting diodes (OLED), have been developed^[10, 20] which provide greater energy efficiency compared with traditional tungsten or fluorescent lamps^[11]. These technologies however, generally provide relatively narrowband, but tunable, emission. Further, the emitted light from these devices can be combined with other technologies, such as quantum dots, which can down-convert emitted light to permit the emission of longer wavelength light, often within highly-selective, narrow emission bands^[3, 15, 22]. These technologies make it possible to create lamps with multiple, frequency-selectable, spectral peaks by combining multiple particles with different physical characteristics. For example, one can use differently-sized quantum dots or different LED materials each of which emit light in a narrow frequency range at a different center frequency. By combining multiple devices, multiple particles or materials in a device, the relative emission at each of the narrow emission bands can be accurately controlled.

A second important aspect of this generation of solid-state lighting devices is their ability to be driven at low voltage, typically less than 10V for any single device, making it possible to use low-cost electronics to precisely control the light output from any individual device. As a result, dynamic, localized control of these electric lights to improve user comfort or to reduce power consumption is being given serious consideration ^[17].

Many applications might benefit from this flexibility, including the creation of electric light that mimics natural daylight with high fidelity. Such a lamp would ideally permit both the spectral content and the color temperature of the illuminant to be adjusted to simulate daylight. It has been shown that the pleasantness of illumination is dependent upon luminance level and color temperature ^[21]. Further, research has shown that the spectral content of the light can influence circadian rhythms and human state of arousal ^[7]. Although providing lamps with spectral content which mimics natural daylight to affect human perception, arousal, and mood might be desirable, another consideration is facility designs which are intended to take advantage of natural illumination to support reduction of the facility's carbon footprint ^[8]. In these facilities, it becomes more likely that natural and electric illumination will be integrated and the level of electrical illumination locally-controlled as a function of available natural illumination ^[17, 20]. In such environments, the variable mixture of natural and electric light, each having significantly different spectral content, is likely to be evident as the human visual system cannot accurately adapt to both light sources simultaneously. In fact, it has been reported ^[12] that in environments with both electric and natural daylight, the contribution of daylight to the environment can be discerned by the color properties of the light in the

environment. Therefore, it is reasonable to expect that differences in the color of natural daylight and electric light will potentially affect the acceptability of these adaptive electric lighting systems, which are designed to only supplement natural daylight.

Electric lamps have been proposed which provide the relative control of three or more light sources, each producing a different color of light to provide a large range of potential white lights ^[1]. These lamps have the capability to adjust the color of light, not only across the range of daylight color temperatures, but to adjust the color of light within large areas of a chromaticity space. Although interesting, this increased flexibility makes control of the light to emulate points on the daylight curve difficult. Others ^[16] have discussed lamps that include only two independently controlled light sources where the chromaticity coordinates of the light produced by each source lie on or near a line that is parallel and near a portion of the daylight locus. The correlated color temperature of the light that is produced by each source is separated by a large distance in chromaticity space as shown in Figure 1. For instance, the light sources can include a cyan-blue and a yellow-white light source located at the endpoints of a line segment shown as the dotted line in Figure 1. As shown, a portion of this line segment lies near a portion of the daylight locus, appearing to the right of the daylight locus for color temperatures from 4000K to about 6500K and to the left of the daylight locus for higher color temperatures. Therefore, by controlling the relative flux produced by each of these two sources, the correlated color temperature of the integrated light produced by the two lamps can be adjusted to provide illumination at multiple correlated color temperatures. However, as described ^[16], the spectra created by the two light sources vary significantly from the spectra of daylight and will typically have a relatively poor color rendering index. It has

further been demonstrated that by applying a relatively large number of representative emitters, the standard daylight curves can be approximated relatively accurately by applying a pair of independently-controlled light sources in a lamp where each light source includes as many as 11 emitters to mimic the shape of the daylight curves^[13]. Unfortunately, the cost of fabricating a lamp can be expected to increase as a function of emitters and therefore, it is desirable to form such a lamp with as few emitters as possible.

The ability to utilize two, well-designed, independently-controlled light sources to produce a range of daylight lighting conditions is appealing. However, the selection of emitters to achieve a high quality metameric match to the standard daylight spectra without requiring an extraordinary number of emitters has not been addressed. In this paper a lamp design is discussed that permits the standard daylight curves to be approximated across a significant portion of the correlated color temperature range that is important in mixed illumination conditions. Further analysis is conducted to understand the effect of the number of optimally arranged spectral peaks on the Color Fidelity Score (CFS) across this range of color temperatures. This analysis includes both 30 nm bandwidth emitters, representing an approximation to inorganic LED emission, and 60 nm bandwidth emitters, representing an approximation to OLED emitters.

Lamp Description

Before describing the lamp to be developed, it is important to clearly define the goals of the lamp. First, the lamp should permit the color temperature of the emitted light to be varied over a range that is consistent with natural daylight. Secondly, the spectra of

the lamp should be adjusted to not only vary the color temperature to be relatively consistent with natural daylight but permit the lamp to create light that, when reflected, provides at least a metameric match, if not a spectral match, to reflected standard daylight. Third, the mechanism for controlling the spectra and the resulting color temperature of the light created by the lamp should be intuitive to a general consumer. One possible interpretation of this third requirement is that the lamp should provide two independent controls, one control for adjusting the spectra and the color temperature of the lamp and a second independent control for adjusting the intensity of the light output by the lamp. As such, if the lamp were to be controlled by the user, the user could manipulate the illuminance provided in an environment without adjusting the color temperature of the illuminant and vice versa. Finally, of course, the design of the lamp should permit a cost-effective solution.

The concept for the current lamp draws inspiration from the work of Judd and colleagues^[9] who conducted an eigenvector analysis of daylight data and found that measured spectral radiant power distributions of daylight could be remarkably well described by linear combinations of the calculated mean spectral distribution and the spectral distribution of the three most important eigenvectors. It was then further noted, that over a restricted range, the spectra of daylight can be approximated by a linear combination of two bracketing daylight spectra. This fact is shown in Figure 2, which shows standard daylight spectra at 4000 and 10,000 K, as well as a linear combination of these two spectra to create light with a color temperature of 6500 K and the standard 6500 K daylight spectra. Note that the linear combination of the 4000 and 10,000 K standard daylight spectra provides a relatively good match to the standard 6500 K

daylight spectra having a RMSE error of only 0.05. Further, the chromaticity coordinates of the linear combination are very near the chromaticity coordinates of the 6500 K daylight spectra, having coordinates that are separated in the 1976 uniform chromaticity space (UCS) diagram by a Euclidean distance of only 0.0044 units. This concept can then be applied to the design of the daylight-matched electric lamp.

The proposed lamp is composed of two, independently-controlled light sources. The first light source will be designed to approximate the spectra of daylight at a low color temperature. The second light source will be designed to approximate the spectra of daylight at a high color temperature. The control of the relative ratio of the light output by these two sources permits the lamp to produce light with intermediate color temperatures between the low and high color temperatures. By varying the intensity of the two light sources while maintaining their relative output, the intensity of the lamp can be adjusted without affecting the color temperature of the lamp. As such, a lamp can be created with relatively simple control electronics that vary the color and intensity of the light independently with an intuitive user interface.

Analysis

To understand the requirements and applicability of such a lamp, an evaluation was undertaken. The primary goal of this evaluation was to understand the requirements for the solid state emitters within each of the lamp's two light sources and to understand whether the resulting spectra for the two light sources could be combined to robustly obtain intermediate CCTs. Before undertaking this analysis, it is necessary to understand

the desired color temperature range of the lamp, to understand metrics for determining the robustness of the lamp, and to define a set of necessary technology constraints.

Color Temperature Range

As stated earlier, a goal of the current lamp is to permit the spectra of the lamp to be adjusted to provide light that, when reflected, provides at least a metameric match to standard daylight over a range that is consistent with natural daylight. It is important that since the primary goal of this analysis is to provide at least a metameric match to reflected light, we are primarily concerned with the spectral content of the lamp within the visible portion of the electromagnetic spectrum and therefore, it is not our goal to represent the spectrum of daylight outside of this range. This work could be extended to include nonvisible (e.g., ultraviolet) energy if desired.

A significant question in the development of this lamp is the range of color temperatures the lamp should produce. Numerous surveys of natural daylight have been conducted over the past century. However, one of the more recent surveys^[6], which includes hemispheric measurement of daylight collected over a 2-year period, has reported that while the elevation of the sun is greater than 5 degrees, 95% of all samples of daylight have color temperatures which range between 5,500 and 10,000 K. Therefore, it is desirable for the lamp to produce color temperatures over at least this range. However, it is recognized that electric illumination is often lower in color temperature than 5,500 K and therefore, there is utility in providing lower color temperatures for times when no daylight is available. As a result, this paper explores a lamp capable of color temperatures ranging from 4000 to 10,000K.

Fidelity Metric

To facilitate this design, it is important to utilize a robust metric to assess the degree of the metameric match of the lamp to the standard daylight sources. Numerous metrics of illumination fidelity have been discussed in the literature, the most popular of which is the Color Rendering Index (CRI) as originally proposed by Nickerson and Jerome^[14] and standardized by the International Commission on Illumination (CIE)^[2]. This metric can be used to assess the quality of light produced by a lamp with respect to a standard source. In doing so, it assumes that a series of eight standard color patches should have the same appearance when illuminated by the lamp as when illuminated by the reference light source. Any difference in appearance of any of the color patches then detract from the value of the color fidelity of the lamp. The concept behind this metric is quite consistent with the overall goal of the current work. That is, the metric can be used to determine the change in appearance of a set of color patches when illuminated by the lamp under design with reference to a standard daylight illuminant.

To calculate the CRI, the reflectance spectra of each of the eight standard color patches are computed, assuming they are illuminated by the reference illuminant and the lamp under consideration. The coordinates of each reflected spectra within the 1964 CIE $W^*U^*V^*$ uniform color space are then computed. For each standard color patch, a Euclidean distance is calculated between the coordinates when illuminated by the reference illuminant and the lamp. These distances are then subtracted from a value of 100 and arithmetically averaged to obtain the CRI. Therefore, a lamp that renders the color patches perfectly with respect to the reference illuminant will have a CRI of 100 and lower values will indicate a lack of rendering fidelity. Generally, it is assumed that

any general-purpose lamp should have a CRI of 70 or greater. Although the CRI has become the metric of choice within the lighting industry over the past several decades, recently it has received significant criticism for not adequately predicting the color quality of certain LED configurations. Perhaps one of the more substantial shortcomings of the CRI metric is the standardized color patches, none of which correspond to a highly saturated color, which will be more sensitive to changes in narrowband input spectra than the standardized color patches.

Recently numerous additional metrics have been defined. Many of these metrics, however, depart from creating a color match to a reference illumination source, attempting to predict a preferred illumination instead ^[19]. As a result, the goals of these metrics are not consistent with the goals of the current research. Perhaps most relevant to the current research is the CFS ^[4]. Like the CRI, the CFS compares the reflected illumination of a lamp to that of a standard reference illuminant. This metric has numerous differences from the CRI, which were designed to make it a superior metric for the evaluation of LED lamps. These differences include specification of 15 highly saturated reflectance samples, as opposed to the 8 unsaturated reflectance samples used to calculate CRI. Further this metric includes a chromatic adaptation function to emulate human adaptation to the reference sample and the application of a more current color space, namely the 1976 CIE L*a*b* uniform color space. Finally, the Root Mean Square Error (RMSE) of the Euclidean distances between the rendered colors for each patch is computed and this value is weighed and subtracted from 100 to provide a final value. Note that this method is designed to include several intended improvements over the CRI metric but provides an equivalent function.

A goal of this paper is to provide at least a robust metameric match to the standard daylight sources. However, if technology barriers were removed, it is desirable to match the spectrum for the standard daylight sources. To understand this goal, metrics such as CRI or CFS are not sufficient. Therefore, two additional metrics are applied in this analysis; including a standard Root Mean Square Error (RMSE) and a visually-weighted Root Mean Square Error (RMSE_v). RMSE is computed by independently normalizing both the maximum value in the standard daylight reference and the lamp spectra to a maximum relative intensity of 1. The RMSE is then calculated by computing the square root of the sum of the squared differences between the daylight and lamp spectra at 2 nm intervals between 380 and 720 nm and normalizing by the number of samples. RMSE_v is computed in an identical fashion with the exception that the difference is multiplied by the normalized photopic visual sensitivity function value at each 2 nm interval prior to being squared. These two metrics are useful in understanding the difference between the daylight spectrum and the lamp spectrum and this difference when weighted by the human visual sensitivity function. Although these metrics are useful in understanding the difference between the daylight curve and the lamp spectrum, they are not sensitive to differences in color between the two spectra and, therefore, are not useful to effect the optimization when the lamp spectrum and the standard daylight spectrum differ by any substantial amount. Therefore, the CFS metric was used to drive the optimization to facilitate the selection of aim spectra with the fewest possible number of emitters. The RMSE and CRI metrics were analyzed and are reported to aid interpretation of the results.

Technology Constraints

As stated earlier, the goal of this paper is to explore a lamp using solid state LED or OLED technology. Therefore, it is assumed that each of the two sources within the lamp will be produced from a number of individual emitters with defined bandwidths and selectable center wavelengths, the emission of which are combined to emulate either a low or high color temperature source. This assumption is consistent with LED technology, which often creates emission that can be approximated a Gaussian function with a full-width at half the maximum amplitude bandwidth of 30 nm, although LEDs often do not provide emission that is truly symmetric about the center wavelength. The center wavelength of the emission of the LEDs can be varied primarily through the selection of materials or combined with quantum dots, which can be manufactured with various radii to adjust color emission. OLED emitters are often not as well behaved as inorganic LEDs or quantum dots, having more complex spectra, often with multiple peak wavelengths. However these emitters are often reported to have bandwidths on the order of 45 to 60 nm.

To simplify the present analysis it is assumed that the lamp will be created from two sources, each source containing a family of emitters. Each emitter is assumed to have a defined center wavelength, a spectral emission that is approximated by a Gaussian distribution and a bandwidth of either 30 nm or 60 nm. The 30 nm bandwidth is intended to represent LED technology or LED technology combined with quantum dots while the 60 nm bandwidth is intended to represent OLED technology. It is further assumed that the center wavelength is not constrained and that each of the two sources within the lamp

will be formed from a family of emitters having different center wavelengths that are combined with a selected intensity.

Analysis Method

To understand the detailed requirements for a daylight lamp employing the solid-state emitters described in the previous section, a computational model was constructed in Matlab[®]. This model determined the optimal placement (e.g., center wavelength) and amplitude for a specified number of emitters to maximize the CFS independently at both 4000 K and 10,000 K. Mixtures of the resulting spectra were then formed to achieve intermediate color temperatures of 5000, 6500, and 8000 K and CFS and CRI values were determined for these intermediate values.

More specifically this model permits the user to specify the aim CCT for each of the two illumination sources, the number of emitters within each source, and the FWHM bandwidth of each emitter in each source. Further, an initial set of center wavelengths with corresponding amplitudes are selected. The center wavelengths and corresponding amplitudes are placed into an array and provided to the routine “fminsearch” within Matlab[®] using the interior-point algorithm. Within this optimization the spectrum for one of the sources is generated, aim daylight spectra for the selected color temperature is generated using the method specified in CIE publication 13.3 [2], and the RMSE of the 1976 CIE $L^*a^*b^*$ difference between the current spectrum and the aim daylight spectrum for the current generated spectrum is then calculated to satisfy the requirements for the CFS. This RMSE value is then minimized through the selection of center wavelengths and amplitudes.

Once this process is completed for one illumination source, the same process is completed for the second illumination source. The relative luminance of the two optimized spectra are then calculated and normalized to provide equal relative luminance of the two illumination sources. The amplitudes of the two sources are then adjusted to determine the spectra for the intermediate color temperature values and the CFS, CRI, RMSE and RMSE_v values are calculated and reported for each of the lamp outputs. Finally, these values are plotted in a 1976 CIE UCS diagram with the daylight curve and the Euclidean distance between each of the pairs of $u'v'$ values for the reference daylight and corresponding lamp values are calculated.

Results

CFS, CRI, and RMSE values are shown in Table 1 as a function of the number of emitters and emitter bandwidths when applying these emitters to optimize the CFS individually for the 4000 K and 10,000 K light sources. As shown in this table, each of the four metrics generally increases as the number of emitters increase, regardless of the bandwidth. CFS values of 95 or greater are obtained when four or more 30 nm bandwidth peaks are optimally placed to form an electric lamp having a CCT of 4000 or 10,000 K. When the bandwidth is increased to 60 nm, the number of peaks required to obtain a CFS of at least 95 decreases from 4 to 3 with respect to standard daylight at 4000K and 3 peaks with a bandwidth of 60 nm nearly produces a CFS of 95, specifically 94.6, with respect to daylight at 10,000 K.

Figure 3 shows the optimized spectra including four, 30 nm emitters or three, 60 nm emitters for each of the 4000 and 10,000 K light sources. Also shown in Figure 3 are

the standard daylight spectra at each of these CCTs. As Figure 3 shows, the resulting spectral peaks are approximately evenly distributed across the visible spectrum for each of the emitters within each light source and although the resulting emission for the optimized spectra are clearly more peaked for the 30 nm emitters than the relatively smooth daylight spectra, there generally are not gaps between the peaks within the lamp spectra where no light emission occurs. The spectra are considerably smoother for the 60 nm emitters. Unfortunately, even when confining the solution to a CFS value of 95 or above, which should force a solution that provides a near metameric match for the standard narrowband patches applied within the CFS, the 30 nm emission spectra appear peaked within the center of the visible spectrum. Further, there is effectively no light emitted at frequencies below 390 nm or above 680 nm for the 30 nm emission spectra. The peaked appearance and lack of energy outside the center of the visual sensitivity function are exhibited by the relatively large RMSE and RMSE_v values. As scaled, the RMSE values range from 0.421 to 0.545 for the spectra formed from the 30 nm bandwidth emitters, which is quite large given that these values range from 0 to some value less than 1.0. Even when weighted by the visual sensitivity function, which should reduce the value to a range from 0 to a value less than 0.28 (e.g., the area under the visual sensitivity function), the resulting RMSE_v values range from 0.145 to 0.178 for the 30 nm emitters. Certainly, the RMSE_v difference between the light sources formed from four emitters with a 30 nm bandwidth and the daylight spectra are not equivalent. These results are somewhat better for the three 60 nm bandwidth emitters with RMSE values ranging from 0.225 to 0.396 and RMSE_v values of 0.020 and 0.028. Further, as the human eye is sensitive over a frequency range to include at least 380 to 720 nm, it is

possible that narrow band reflectors with spectral reflectance near the extremes of the visual sensitivity function would appear different when illuminated by a lamp having the emission shown and daylight, especially for the 30 nm bandwidth emitters. Therefore, both the peaked emission and the constrained range of light emission present possible issues with the lamp spectra formed from the 30 nm bandwidth emitters if a true color match is necessary and the reflectance of the objects in the environment either have narrower reflectance spectra or are positioned differently than the 15 standard patches used in the CFS calculations.

To understand the potential advantage of including additional emitters, Figure 4 shows data similar to Figure 3, only including additional emitters within each light source to include five unique 30 nm emitters or four unique 60 nm emitters within each light source. As shown in Figure 4, the resulting emission spectra are less peaked and cover a broader range of the visible spectrum for the 30 nm emitters. As shown, the resulting spectra includes some (at least .01 percent of the peak) energy at wavelengths as short as 386 nm for the 10,000 K source and as long as 706 nm for the 4000 K source. Although the addition of these emitters improve the CFS only marginally (i.e., 1.2 to 3.2 values, depending upon the condition), the spectra appear to better mimic the daylight spectra. The improvement in fit is illustrated by greater than 10% improvement in each and every RMSE value. Even greater improvements are generally witnessed for the RMSE_v values, with the exception of the 60 nm low CCT source condition. For this condition, RMSE_v increased as the emission from the two emitters with the most extreme values were shifted towards the edges of the visual sensitivity function, resulting in an increase in the

RMSE_v values for wavelengths near the center of the visual sensitivity function to which this metric is most sensitive.

Thus far, formation of spectra for the two extreme CCTs has been discussed. However, the question to be addressed is whether by modulating the relative energy of only the two light sources, the spectra of which are depicted in Figures 3 and 4, will permit the creation of light at intermediate CCTs and having a high CFS. Therefore, in the following analysis, the placement and relative amplitude of the emission peaks in each resulting spectrum formed to support the calculations in Table 1 were fixed and the relative intensity of the emission spectra at 4000 and 10,000 K were varied to produce light with intermediate CCTs. Table 2 provides CFS values for the resulting light emission at the intermediate CCTs of 5000, 6500, and 8000 K. As shown in Table 2, CFS values that result at the intermediate CCTs are always higher than the CFS values for at least the lowest of the CFS values produced by the 4000 and 10,000 K illumination sources. Therefore, the mixture of light from two independently controlled sources can achieve the intermediate CCT values and the resulting spectra are generally improved with respect to original light source having the lowest CFS. Perhaps this is not surprising as the emission spectra for the 4000 and 10,000K sources were independently selected and therefore the light created for the intermediate CCTs is composed of twice as many unique emitters as the light that is created from either bracketing spectra. Unfortunately, the use of unique emitters within each light source potentially increases the complexity necessary to fabricate the lamp due to the need for up to 10 unique emitters.

The fact that the light from the resulting sources can be adjusted to provide the appropriate CCTs does not imply accuracy of the color of light with respect to the standard daylight values. Table 3 shows the error between the chromaticity coordinates of the lamps and the standard daylight values by indicating a Euclidean distance between the $u'v'$ coordinates of the standard daylight source and the resulting lamps. As shown, the correspondence between the chromaticity coordinates of the lamp and the standard daylight chromaticity coordinates is quite good, with a maximum error less than 0.01. Figure 5 shows the relevant portion of the daylight curve and the UCS chromaticity coordinates for one of the conditions, specifically the condition employing four, 30 nm bandwidth emitters. As shown, the optimized values lie very near the daylight curve.

One remaining question is whether it is necessary to fabricate the two light sources from independently-selected emitters. As a result, the optimization routine was modified to require the two light sources to share common emitters with varying amplitude. In this optimization, minimum of the CFS score between the CFS values for the high and low CCT light sources was maximized, assuming the same emitting materials or devices were present within the two light sources. The results of this analysis are depicted in Tables 4 and 5. As shown, CFS values in the 90s can be achieved with as few as four emitters at either bandwidth. However, CFS values greater than 95 cannot be reliably achieved across all color temperatures with 6 or fewer common emitters. Figure 6 shows the spectra of optimized spectra when a set of commonly-selected five, 30 nm emitters or four 60 nm emitters are employed in each light source. As shown, the 30 nm emitters provide a relatively peaked emission spectrum for either color temperature. Interestingly only 4 peaks are clearly visible

within this spectrum, with the fifth peak providing a relatively small amount of energy at a peak wavelength of 455 nm. Further, the spectra produced by the 30 nm bandwidth emitters include almost no energy beyond about 670 nm. The spectra formed from the 60 nm bandwidth emitters is significantly more smooth and covers a broader range of the spectrum.

Finally, Table 6 shows the distance between the 1976 UCS coordinates for the lamps having a pair of light sources with common emitters and the aim daylight coordinates. As shown, the values in Table 6 are consistently higher than the values in Table 3, which permitted the unique selection of emitters within each light source to improve the quality of light. That is the constraint of common emitters increases the chromaticity errors between the lamp and standard daylight. However, when at least five, 30 nm bandwidth emitters or three, 60 nm bandwidth emitters are employed, the distance is typically less than 0.01 across the entire range of daylight values. The one exception to this finding is the lamp having six 30 nm bandwidth emitters which has distance slightly greater than 0.01 for the 6500 and 8000 K values.

Conclusion

A concept for a lamp designed to produce a near metameric match to daylight as the color of daylight varies between 4000 and 10,000K has been proposed. This lamp is intended to be used in a mixed illumination environment containing natural and electric light. This lamp is expected to permit the correlated color temperature, and to some degree the spectral shape, of the standard daylight curves to be reproduced for more than 95% of the daylight hours. Besides matching daylight to permit robust dynamic control

of electric light as a function of available daylight to reduce power consumption, such lamps may have multiple other applications, possibly including the regulation of biorhythms through mimicking natural illumination within electrically-lit environments, permitting improvement in productivity for shift workers among others ^[5].

The proposed lamp is designed to have only two independently-controlled light sources where each light source is formed from a group of commonly controlled emitters. As the relative output of the two light sources is varied, the color temperature of the light varies. By controlling the amplitude of the output from the two lamps, while maintaining their relative output, the lamp luminance can be controlled without affecting the color of the light produced by the lamp, assuming the emitters obey the additivity assumptions of this analysis. As such, this lamp permits a relatively simple control scheme which should be intuitive to consumers.

Further, an initial analysis was performed to assess the influence of the number of spectral peaks, corresponding to different inorganic LED or OLED emitting materials, on the fidelity of the light produced from the lamp with respect to standard daylight spectra. When applying emitters with a FWHM bandwidth of 30 nm, corresponding to inorganic LED or quantum dot technologies, it is recommended that each light source be composed of at least 4 and preferably at least 5 unique emitters. When the bandwidth is increased to 60 nm, it is recommended that each light source be composed of at least 3 and preferably 4 unique emitters. In each case, the lower number of emitters can provide CFS values of 95 or greater when the emitters are optimally chosen and tuned. However, the larger number of emitters provides coverage over a larger portion of the visible spectrum. Further, the analysis indicated that mixing light from two-independently controlled light

sources, one at 4000K and one at 10,000K, can be accomplished to provide a good match to daylight at intermediate correlated color temperatures. If it is further assumed that the emitters must be common within each light source, but controlled with different amplitudes, at least 5 common emitters will be required for bandwidths of 30 nm or less. The number of recommended common emitters is not affected when the bandwidth is 60 nm.

The included analysis provides optimized values for theoretical emitter spectra. It is realized that although the present LED technologies provide more flexibility than many other lighting sources, it is unlikely that the optimized spectra shown in this paper could be easily achieved. Therefore, future research will involve demonstrating a lamp utilizing this concept and understanding the practical limitations of this theoretical analysis.

References

- [1] Aldrich M, Paradiso J., Zhao N. Energy efficient control of polychromatic solid state lighting using a sensor network. Proceedings of the SPIE; August 2010. 7784 p. 778408.
- [2] CIE. Method of measuring and specifying color rendering properties of light sources. in CIE Publication 13.3, Vienna, Austria; 1974.
- [3] Dabbousi BO, Rodriguez-Viejo J, Mikulek FV, Heine JR, Matoussi H, Ober R, Jensen KF, Bawendi MG. (CdSe) ZnS core-shell quantum dots: Synthesis and characterization of a size series of highly luminescent nanocrystallites. J of Phys Chem 1997;101(46):9463-75.
- [4] Davis W, Ohno Y. Color quality scale. Opt Engr 2010;49(3):033602-1,033602-15.

- [5] Figueiro MG, Rea MS. Sleep opportunities and periodic light exposures: Impact on biomarkers, performance and sleepiness. *Lighting Res. Technol.* 2011 43: 349-369.
- [6] Hernandez-Andres J, Romero J, Nieves JL, Lee Jr, R.L. Color and spectral analysis of daylight in southern Europe. *J Opt Soc Am A* 2001;18(6):1325-35.
- [7] Iwakiri K, Y. Effects of spectral distribution of light on the arousal level in humans. *Systems, Man, and Cybernetics, IEEE SMC '99 Conference Proceedings;* 1999;2:271.
- [8] Jarnagin R, Colliver D, Deringer J, Edelson J, Enck J, lane M, McBride M, McKay H, Misuriello H, Nall D, Steinder D, Leban D, Hunn B. *Advanced energy design guide for small office buildings.* Atlanta, GA: American Society of Heating, Refrigerating and Air-Conditioning Engineers; 2004. Report nr 2004110374.
- [9] Judd DB, MacAdam DL, Wyszecki GW. Spectral distribution of typical daylight as a function of correlated color temperature. *J Opt Soc Am* 1964;54:1031.
- [10] Kuo CP, Fletcher RM, Osentowski TD, Lardizabal MC, Craford MG, Robbins VM. High performance AlGaInP visible light-emitting diodes. *Appl Phys Lett* 1990 57(27):2937-9.
- [11] Lenk R, Lenk C. *Practical lighting design with LEDs.* New York: Wiley-IEEE Press; 2011.
- [12] Mayoub MS, Carter DJ. Towards hybrid lighting systems: A review. *Lighting Res. Technol.* 2010 42:51-71.
- [13] Miller ME, Madden TE, Cok RS, Kane PJ. Lamp with adjustable color. US Patent 7,759,854.
- [14] Nickerson D, Jerome CW. Color rendering of light sources: CIE method of specification and its application. *Illum Eng* 1965;60:262-71.
- [15] Nizamoglu S, Zengin G, Demir HV. Color-converting combinations of nanocrystal emitters for warm-white light generation with high color rendering index. *Appl Phys Lett* 2008 21;92(3):031102(3).
- [16] Okumura Y, inventor. Color temperature-regulable led light. US Patent Application 10/487,528. 2004.

- [17] Patel M, Esscoe A, Mukherjee S, Birru D. Preliminary results from an integrated lighting and daylight control demonstration at Fort Irwin. Proc of the IES; October 2011.
- [18] Sarkar A, Fairchild M, Salvaggio C. Integrated daylight harvesting and occupancy detection using digital imaging. Proc SPIE-IS&T Elec Imag Conf; 2008. 6816DF-1-12
- [19] Smet K, Rychaert WR, Pointer MR, Deconinck G, Hanselaer P. Correlation between color quality metric predictions and visual appreciation of light sources. Optics Express 2011;19(9):8151-66.
- [20] Tang CW, VanSlyke SA. Organic electroluminescent diodes. Applied Physics Letters 1987;51(12):913-5.
- [21] Vienot F, Durand M, and Mahler E. Kruithof's rule revisited using LED illumination. Journal of Modern Optics 2009;56(13):1433-46.
- [22] Zou J, Liu J, Wu H, Yang W, Peng J, Cao Y. High-efficiency and good color quality white light-emitting devices based on polymer blend. Organic Electronics 2009;10(5):843(6).

Biographies

Michael E. Miller, PhD is an Assistant Professor of Human Systems Integration at the Air Force Institute of Technology. His research interests include human systems integration, modeling and measurement of human performance and human interface design, particularly human-display integration. Prior to joining AFIT, Dr. Miller spent more than 15 years with Eastman Kodak Company as a systems and human factors engineer. Dr. Miller holds over 60 US Patents in digital imaging and OLED systems. He is a senior member of SID, a member of the Human Factors and Ergonomics Society, a senior member of the IIE, and a member of INCOSE.

Jacob M. Gilman is a Captain in the United States Air Force and completing his Master of Science at the Air Force Institute of Technology. His research focus includes daylight approximation through blending LED sources and driving schemes for simple LED lamp implementation and operation for the purpose of supplementing natural daylight within facility spaces. Upon degree completion, Capt Gilman will continue his more than nine years of service within the Air Force Civil Engineer career field. Prior to his selection to attend AFIT, Capt Gilman held positions at both squadron and major command levels of responsibility and completed three combat tours within Iraq and Afghanistan. Additionally he is a member of the Society of American Military Engineers (SAME) and Sigma Iota Epsilon (SIE).

John Colombi, Ph.D. is an Assistant Professor of Systems Engineering at the Air Force Institute of Technology (AFIT), Wright-Patterson AFB. He received his Ph.D. in 1996 and M.S. in 1992 from AFIT. He has 21 years of military experience retiring from

the US Air Force in 2007. Dr. Colombi led systems engineering for the E-3 aircraft, he served at the National Security Agency developing biometrics and information security, and he researched communications networking at Air Force Research Laboratory. His research interests include systems and enterprise architecture, complex adaptive systems and human systems integration. He is a member of INCOSE and IEEE.

List of Figures

Figure 1. A portion of a 1976 uniform chromaticity space diagram depicting chromaticity coordinates of a pair of emitters, shown as squares, which are capable of reproducing light along a line, indicated by the dashed line. The dashed line approximates a range of values on the daylight locus, shown as the curved solid line.

Figure 2. Illustration of computed daylight spectra for 4000 (bold solid line), 6500 (solid line), and 10,000 K (bold dash dot) standard light sources and an approximation of the 6500 K daylight spectra (dashed line).

Figure 3. Spectra for a low (thin black line) and high (bold blue line) CCT spectra with dashed line representing optimized lamp spectra and solid lines representing standard daylight spectra. Left panel depicts solution with four 30 nm FWHM Gaussian distributions; right panel depicts solution with three 60 nm FWHM Gaussian distributions per spectra.

Figure 4. Spectra for a low (thin black line) and high (bold blue line) CCT spectra with dashed line representing optimized lamp spectra and solid lines representing standard daylight spectra. Left panel depicts solution with five, 30 nm FWHM Gaussian distributions; right panel depicts solution with four, 60 nm FWHM Gaussian distributions per spectra.

Figure 5. a 1976 $u'v'$ diagram depicting chromaticity coordinates created from the optimized lamp spectra for the four emitter, 30 nm bandwidth condition, shown as squares, and a portion of the standard daylight curve ranging from 4000 to 10,000 K.

Figure 6. Spectra for a low (thin black line) and high (bold blue line) CCT spectra with dashed line representing optimized lamp spectra and solid lines representing standard

daylight spectra. Left panel depicts solution with five common, 30 nm FWHM Gaussian distributions; right panel depicts solution with four common, 60 nm FWHM Gaussian distributions per spectra.

Figures

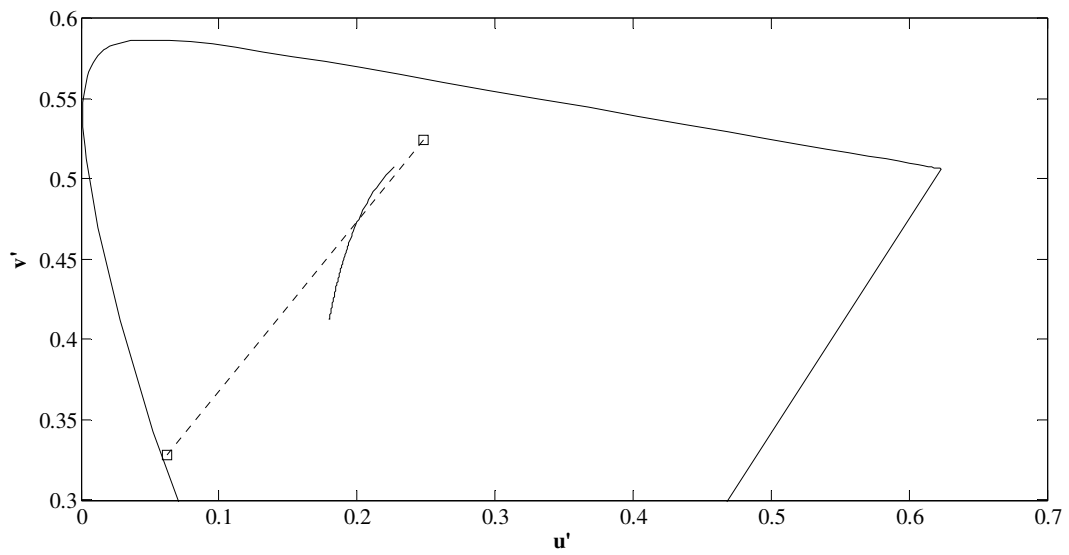

Figure 1. A portion of a 1976 uniform chromaticity space (UCS) diagram depicting chromaticity coordinates of a pair of emitters, shown as squares, which are capable of reproducing light along a line, indicated by the dashed line. The dashed line approximates a range of values on the daylight locus, shown as the curved solid line.

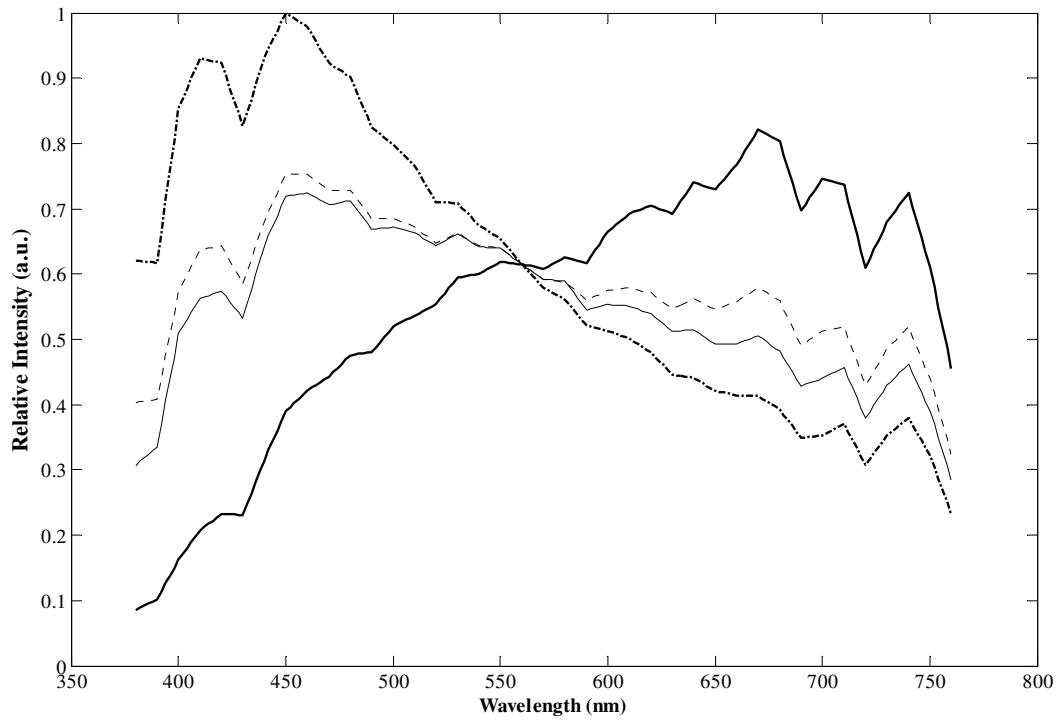

Figure 2. Illustration of computed daylight spectra for 4000 K (bold solid line), 6500 K (solid line), and 10,000 K (bold dash dot) standard light sources and an approximation of the 6500 K daylight spectra (dashed line).

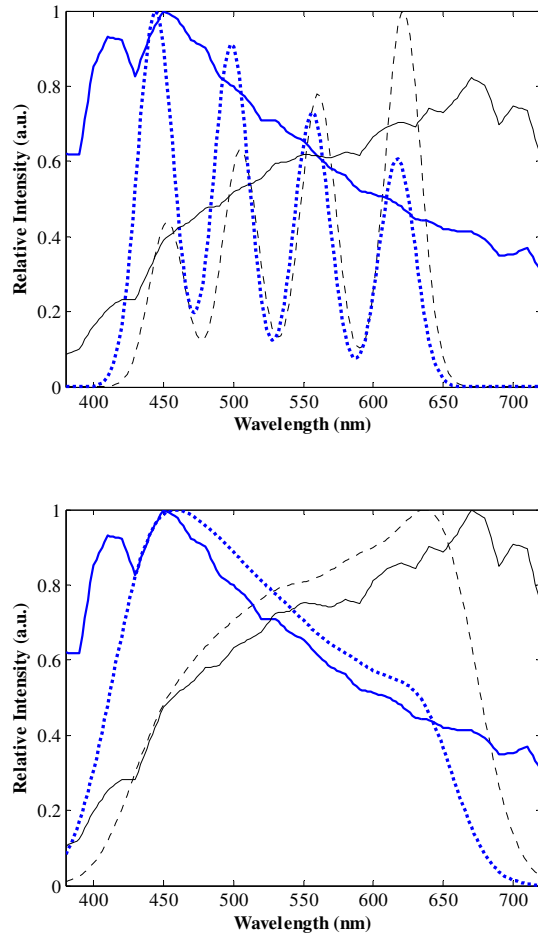

Figure 3. Spectra for a low (thin black line) and high (bold blue line) CCT spectra with dashed line representing optimized lamp spectra to achieve a CFS of about 95 and solid lines representing standard daylight spectra. Left panel depicts solution with four 30 nm FWHM Gaussian distributions per light source; right panel depicts solution with three 60 nm FWHM Gaussian distributions per light source.

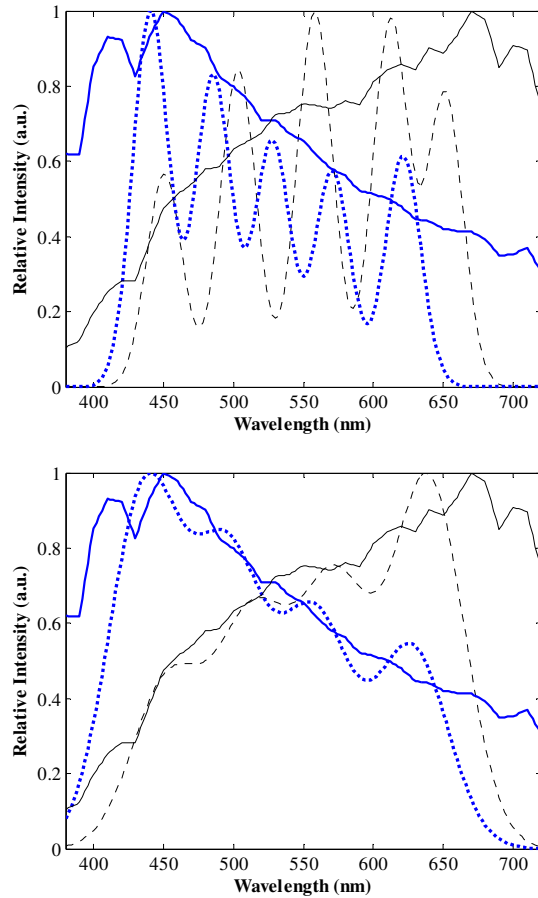

Figure 4. Spectra for a low (thin black line) and high (bold blue line) CCT spectra with dashed line representing optimized lamp spectra and solid lines representing standard daylight spectra. Left panel depicts solution with five, 30 nm FWHM Gaussian distributions per light source; right panel depicts solution with four, 60 nm FWHM Gaussian distributions per light source.

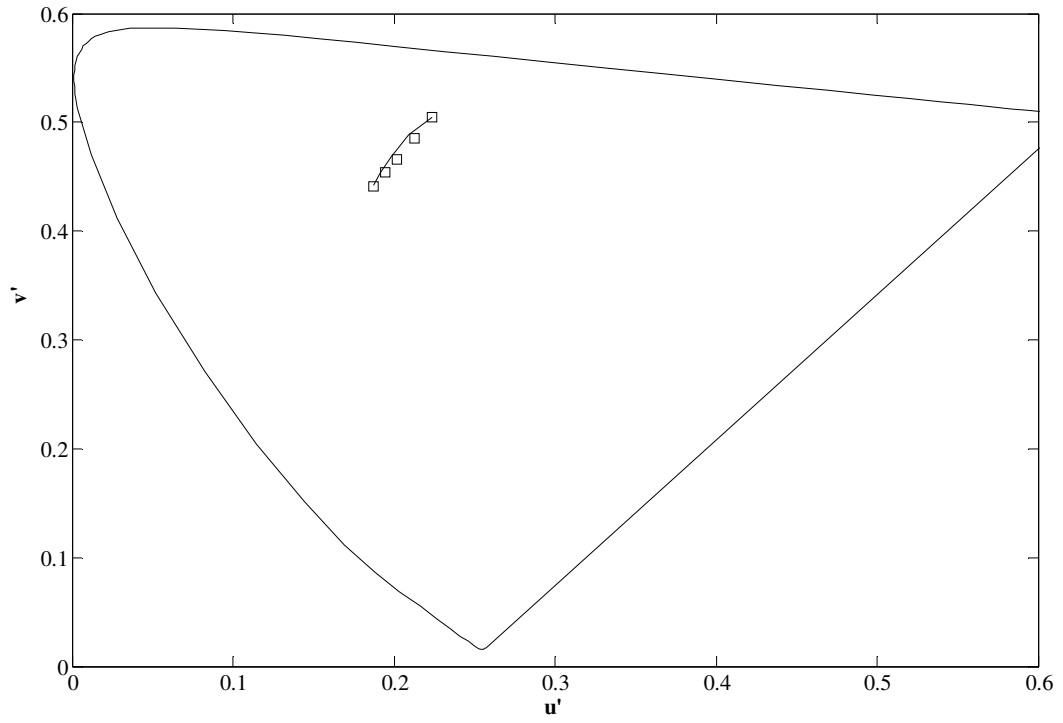

Figure 5. a 1976 $u'v'$ diagram depicting chromaticity coordinates created from the optimized lamp spectra for the four emitter, 30 nm bandwidth condition, shown as squares, and a portion of the standard daylight curve ranging from 4000 to 10,000 K.

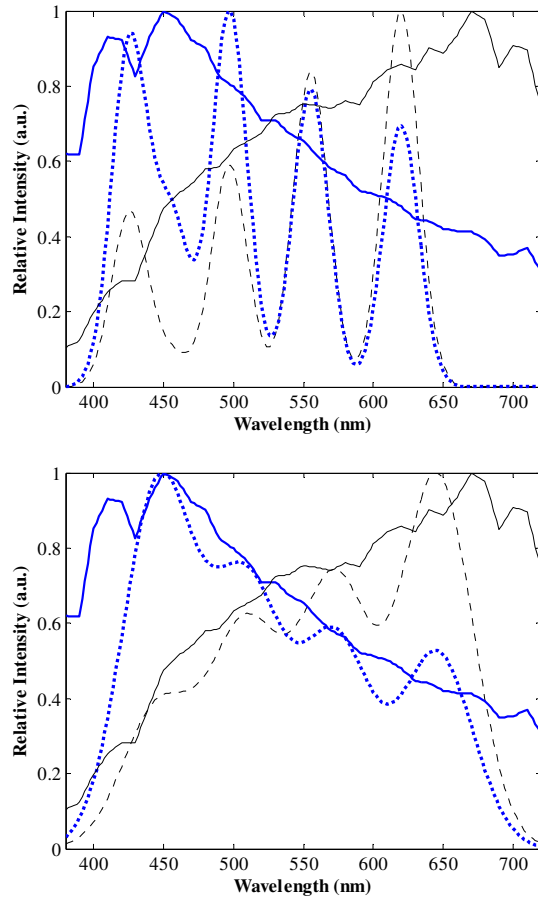

Figure 6. Spectra for a low (thin black line) and high (bold blue line) CCT spectra with dashed line representing optimized lamp spectra and solid lines representing standard daylight spectra. Left panel depicts solution with five common, 30 nm FWHM Gaussian distributions; right panel depicts solution with four common, 60 nm FWHM Gaussian distributions per spectra.

Tables

Table 1. Optimized Color Fidelity Score as a function of the number of emitters in each light source at each bandwidth.

Number of Emitters	30 nm Bandwidth Gaussian Emitters							
	Low CCT Source				High CCT Source			
	CFS	CRI	RMSE	RMSE _v	CFS	CRI	RMSE	RMSE _v
2	25.9	-14.6	0.632	0.260	21.8	-47.8	0.546	0.231
3	85.5	76.8	0.576	0.201	84.4	76.03	0.490	0.178
4	96.5	97.4	0.545	0.178	95.0	96.1	0.421	0.145
5	97.7	98.0	0.468	0.145	95.7	95.9	0.375	0.101
6	99.1	98.1	0.433	0.104	96.0	98.0	0.308	0.074
Number of Emitters	60 nm Bandwidth Gaussian Emitters							
	Low CCT Source				High CCT Source			
	CFS	CRI	RMSE	RMSE _v	CFS	CRI	RMSE	RMSE _v
2	67.4	46.6	0.529	0.144	64.6	35.8	0.426	0.153
3	96.2	93.6	0.439	0.058	94.6	92.6	0.316	0.061
4	99.4	98.7	0.396	0.028	95.9	98.7	0.225	0.020
5	99.8	99.5	0.280	0.035	96.0	98.8	0.191	0.015
6	99.6	98.7	0.350	0.010	96.0	98.9	0.142	0.010

Table 2. Color Fidelity Score for each of the aim CCT values.

30 nm Bandwidth Gaussian Emitters					
Emitters in Each Light Source	Color Temperature (K)				
	4000	5000	6500	8000	10000
2	25.9	19.6	24.4	23.2	21.8
3	85.5	84.2	84.5	84.2	76.0
4	96.5	97.1	91.2	92.2	95.0
5	97.7	98.8	92.0	92.7	95.7
6	99.1	99.2	92.2	92.8	96.0
60 nm Bandwidth Gaussian Emitters					
Emitters in Each Light Source	Color Temperature (K)				
	4000	5000	6500	8000	10000
2	67.4	63.3	66.5	65.4	64.6
3	96.2	95.6	92.2	92.5	94.6
4	99.4	99.5	92.2	92.8	95.9
5	99.8	99.6	92.2	92.8	96.0
6	99.6	99.8	92.2	92.8	96.0

Table 3. UCS Error at each of the CCT for spectra including individually-optimized emitters at 4000 and 10,000 K.

30 nm Bandwidth Gaussian Emitters					
Emitters in Each Light Source	Color Temperature (K)				
	4000	5000	6500	8000	10000
2	0.0082	0.0059	0.0095	0.0094	0.0152
3	0.0021	0.0046	0.0058	0.0042	0.0025
4	0.0003	0.0041	0.0042	0.0026	0.0003
5	0.0002	0.0046	0.0052	0.0033	0.0005
6	0.0002	0.0045	0.0044	0.0025	0.0001
60 nm Bandwidth Gaussian Emitters					
Emitters in Each Light Source	Color Temperature (K)				
	4000	5000	6500	8000	10000
2	0.0042	0.0059	0.0089	0.0077	0.0064
3	0.0006	0.0044	0.0051	0.0034	0.0008
4	0.0001	0.0041	0.0042	0.0025	0.0001
5	0.0001	0.0046	0.0044	0.0024	0.0001
6	0.0001	0.0049	0.0057	0.0038	0.0001

Table 4. Optimized Color Fidelity Score as a function of the number of common emitters across each light source at each bandwidth.

Number of Emitters	30 nm Bandwidth Gaussian Emitters							
	Low CCT Source				High CCT Source			
	CFS	CRI	RMSE	RMSE _v	CFS	CRI	RMSE	RMSE _v
2	18.5	-65.4	0.633	0.252	19.2	-6.84	0.549	0.234
3	82.5	75.7	0.588	0.212	83.7	83.8	0.484	0.175
4	91.7	86.7	0.556	0.182	92.3	91.0	0.429	0.142
5	92.8	90.8	0.553	0.184	93.1	86.3	0.373	0.145
6	92.4	76.5	0.409	0.165	94.1	76.9	0.379	0.129
Number of Emitters	60 nm Bandwidth Gaussian Emitters							
	Low CCT Source				High CCT Source			
	CFS	CRI	RMSE	RMSE _v	CFS	CRI	RMSE	RMSE _v
2	57.0	13.2	0.539	0.1482	61.9	37.1	0.432	0.150
3	90.1	90.0	0.430	0.056	90.5	71.2	0.342	0.075
4	98.9	97.5	0.371	0.051	95.5	95.5	0.246	0.032
5	94.9	93.2	0.307	0.042	95.0	91.7	0.152	0.047
6	94.7	86.2	0.406	0.029	96.8	82.7	0.260	0.029

Table 5. Color Fidelity Score for each of the aim CCT values.

30 nm Bandwidth Gaussian Emitters					
Emitters in Each Light Source	Color Temperature (K)				
	4000	5000	6500	8000	10000
2	18.5	18.0	18.4	19.5	19.2
3	82.5	84.7	82.0	82.5	83.7
4	91.7	92.7	90.2	90.8	92.3
5	92.8	93.9	90.0	91.0	93.1
6	92.4	93.9	94.0	93.2	94.1
60 nm Bandwidth Gaussian Emitters					
Emitters in Each Light Source	Color Temperature (K)				
	4000	5000	6500	8000	10000
2	57.0	56.7	60.7	63.6	61.9
3	90.1	90.2	89.6	89.3	90.5
4	98.9	98.7	91.9	92.5	95.5
5	95.0	95.1	92.4	92.9	95.0
6	94.7	95.7	93.5	94.6	96.8

Table 6. UCS Error at each of the CCT for spectra including individually-optimized emitters at 4000 and 10,000 K.

30 nm Bandwidth Gaussian Emitters					
Emitters in Each Light Source	Color Temperature (K)				
	4000	5000	6500	8000	10000
2	0.2155	0.1934	0.1708	0.1563	0.1438
3	0.1233	0.1058	0.0904	0.0816	0.0748
4	0.0109	0.0073	0.0097	0.0129	0.0157
5	0.0068	0.0044	0.0029	0.0051	0.0088
6	0.0044	0.0074	0.0102	0.0118	0.0157
60 nm Bandwidth Gaussian Emitters					
Emitters in Each Light Source	Color Temperature (K)				
	4000	5000	6500	8000	10000
2	0.2125	0.1904	0.1679	0.1534	0.1412
3	0.0010	0.0055	0.0069	0.0049	0.0034
4	0.0003	0.0043	0.0045	0.0029	0.0005
5	0.0006	0.0043	0.0051	0.0035	0.0011
6	0.0016	0.0035	0.0035	0.0015	0.0024

VI. Conclusions and Recommendations

A concept for a simplified approach to constructing a lamp with adjustable CCT and daylight-approximating spectra was discussed. The theory behind this lamp concept was developed through computer modeling to determine an ideal number of emitters and the center frequency locations of each emitter from which each of the two sources within this lamp should be constructed. Analysis indicated that a lamp having two sources comprised of common emissive peaks would require at least five 30 nm or three 60 nm emitters to maintain a color fidelity score of at least 90. However, physically achieving a source with such specific center frequencies is likely to be very difficult. Nevertheless, this analysis provides guidance for future development of this concept.

An additional model was developed to calculate individual LED dimming levels for source creation using two novel dual-PWM driving schemes, one of which was demonstrated through a prototype LED lamp. This prototype demonstrated that approximation of daylight spectra over a wide range of CCTs, while maintaining a relatively constant color quality score, is possible without the requirement for ongoing complex calculations within the lamp. Adjustment of the lamp's CCT is simple and straightforward through a single resistor value. Although demonstrated with discrete inorganic LEDs, the concept can be expanded to white inorganic and organic LEDs or other modified emitters as well as overall lamp luminance control.

A daylight-matching lamp presents a wide range of possible applications and future research. Hybrid daylighting system quality could be improved by delivering light with a CCT equivalent to external daylight across the entire facility space. The cool

temperature, simple controls, and high efficacy of LEDs would allow for distributed, daylight-matched, supplemental illumination at the desired local point of delivery. Another application would allow occupants to adjust a lamp's CCT to fit the task or mood of the space. Further application could be found in enclosed, secure facilities where occupants are without any exposure to daylight over long work shifts, whether during the day or at night. A lamp based on the concepts presented in this work could be controlled to slowly vary the CCT and spectra of the emitted light over the course of the shift to mimic natural daylight variation over the course of a typical day. Additional research is needed to better understand the possible affects such a lamp might have on biorhythm maintenance, arousal, and task performance as well as user luminance preferences in environments illuminated with supplemental daylight-matched electric light. Additional research is also needed to better understand the performance of LED and OLED emitters under the dual-PWM and time-shared dual-PWM driving schemes that have been demonstrated and proposed within this thesis.

Future facility lighting systems employing the blending concept presented in this work have the potential to greatly reduce electrical energy consumption and provide occupants with quality illumination throughout the space. Improving LED efficacies will likely surpass all existing electric lighting technology, making LEDs the most efficient and flexible method for producing light from an electric source and will play an important role in reducing electrical energy consumption as progress is made toward achieving net-zero buildings goals. Hopefully, integrating daylight-approximating LED lighting systems into facilities lacking access to natural daylight will be successfully applied to improve the performance and health of occupants.

If LEDs continue to perform at or above predicted levels, the future of solid-state facility lighting is truly bright – promising to deliver high-quality, beneficial, adjustable illumination, indistinguishable from natural daylight.

REPORT DOCUMENTATION PAGE

Form Approved
OMB No. 074-0188

The public reporting burden for this collection of information is estimated to average 1 hour per response, including the time for reviewing instructions, searching existing data sources, gathering and maintaining the data needed, and completing and reviewing the collection of information. Send comments regarding this burden estimate or any other aspect of the collection of information, including suggestions for reducing this burden to Department of Defense, Washington Headquarters Services, Directorate for Information Operations and Reports (0704-0188), 1215 Jefferson Davis Highway, Suite 1204, Arlington, VA 22202-4302. Respondents should be aware that notwithstanding any other provision of law, no person shall be subject to any penalty for failing to comply with a collection of information if it does not display a currently valid OMB control number.

PLEASE DO NOT RETURN YOUR FORM TO THE ABOVE ADDRESS.

1. REPORT DATE (DD-MM-YYYY) 22-03-2012			2. REPORT TYPE Master's Thesis		3. DATES COVERED (From - To) Aug 10 - Mar 12	
4. TITLE AND SUBTITLE Simplified Daylight Spectrum Approximation by Blending Two Light Emitting Diode Sources				5a. CONTRACT NUMBER		
				5b. GRANT NUMBER		
				5c. PROGRAM ELEMENT NUMBER		
6. AUTHOR(S) Jacob M. Gilman, Captain, USAF				5d. PROJECT NUMBER N/A		
				5e. TASK NUMBER		
				5f. WORK UNIT NUMBER		
7. PERFORMING ORGANIZATION NAMES(S) AND ADDRESS(S) Air Force Institute of Technology Graduate School of Engineering and Management (AFIT/EN) 2950 Hobson Way, Building 640 WPAFB OH 45433-7765				8. PERFORMING ORGANIZATION REPORT NUMBER AFIT/GEM/ENV/12-M06		
9. SPONSORING/MONITORING AGENCY NAME(S) AND ADDRESS(ES) Air Force Civil Engineer Support Agency, Operations and Programs Support Dr Daryl Hammond 139 Barnes Dr, Suite 1 Tyndall AFB, FL 32403 (850) 283-6352 (DSN 523) daryl.hammond@us.af.mil				10. SPONSOR/MONITOR'S ACRONYM(S) AFCESA/CEOA		
				11. SPONSOR/MONITOR'S REPORT NUMBER(S)		
12. DISTRIBUTION/AVAILABILITY STATEMENT DISTRIBUTION STATEMENT A. APPROVED FOR PUBLIC RELEASE; DISTRIBUTION IS UNLIMITED.						
13. SUPPLEMENTARY NOTES						
14. ABSTRACT Energy-conscious facility designs strive to include natural daylight in workspaces. To improve the efficiency of illumination, significant efforts are underway to adopt more efficient light emitting diode (LED) lamps and to effectively integrate daylight with active dimming of electric lighting. However, the correlated color temperature (CCT) and spectral content of daylight varies throughout the day while existing electric light sources produce light with a fixed CCT, resulting in mixed-illumination environments. The color rendering requirements for a lamp that permits the selection of color temperature across a significant portion of the daylight locus is explored. The analysis indicates that it is possible to form a lamp having only two independently controllable groups of narrowband emitters which is capable of producing light that achieves a nearly colorimetric match to daylight from 4000-10,000K. A prototype LED lamp, with a simple control and novel drive scheme, which produces white light over a range of CCTs by blending light from a pair of sources, each with numerous, tuned LED emitters, is demonstrated. The prototype validates the lamp concept; producing light over a broad range of CCT values (4000-8000K) while maintaining a stable color quality rendering score without requiring computations for spectral approximation once employed.						
15. SUBJECT TERMS Light emitting diode, daylight matching, correlated color temperature, prototype lamp, simplified blending						
16. SECURITY CLASSIFICATION OF:			17. LIMITATION OF ABSTRACT	18. NUMBER OF PAGES	19a. NAME OF RESPONSIBLE PERSON	
a. REPORT	b. ABSTRACT	c. THIS PAGE			Michael E. Miller, PhD	
U	U	U	UU	113	19b. TELEPHONE NUMBER (Include area code) (937) 255-6565, x 4651 (michael.miller@afit.edu)	