



# NAVAL POSTGRADUATE SCHOOL

MONTEREY, CALIFORNIA

## THESIS

**SPACE SITUATIONAL AWARENESS CUBESAT CONCEPT  
OF OPERATIONS**

by

Tolulope E. O'Brien

December 2011

Thesis Advisor:

Thesis Co-Advisor:

Second Reader:

Alan D. Scott

James H. Newman

James A. Horning

**Approved for public release; distribution is unlimited**

THIS PAGE INTENTIONALLY LEFT BLANK

REPORT DOCUMENTATION PAGE			Form Approved OMB No. 0704-0188	
Public reporting burden for this collection of information is estimated to average 1 hour per response, including the time for reviewing instruction, searching existing data sources, gathering and maintaining the data needed, and completing and reviewing the collection of information. Send comments regarding this burden estimate or any other aspect of this collection of information, including suggestions for reducing this burden, to Washington headquarters Services, Directorate for Information Operations and Reports, 1215 Jefferson Davis Highway, Suite 1204, Arlington, VA 22202-4302, and to the Office of Management and Budget, Paperwork Reduction Project (0704-0188) Washington DC 20503.				
1. AGENCY USE ONLY (Leave blank)		2. REPORT DATE December 2011	3. REPORT TYPE AND DATES COVERED Master's Thesis	
4. TITLE AND SUBTITLE Space Situational Awareness CubeSat Concept of Operations			5. FUNDING NUMBERS	
6. AUTHOR(S) O'Brien, Tolulope, E.				
7. PERFORMING ORGANIZATION NAME(S) AND ADDRESS(ES) Naval Postgraduate School Monterey, CA 93943-5000			8. PERFORMING ORGANIZATION REPORT NUMBER	
9. SPONSORING /MONITORING AGENCY NAME(S) AND ADDRESS(ES) N/A			10. SPONSORING/MONITORING AGENCY REPORT NUMBER	
11. SUPPLEMENTARY NOTES The views expressed in this thesis are those of the author and do not reflect the official policy or position of the Department of Defense or the U.S. Government. IRB Protocol number <u>    N/A    </u> .				
12a. DISTRIBUTION / AVAILABILITY STATEMENT Approved for public release; distribution is unlimited			12b. DISTRIBUTION CODE	
13. ABSTRACT (maximum 200 words)  The concept of space situational awareness (SSA) is important to preserve manned and unmanned space operations. Traditionally, ground based radar, electro-optical sensors and very limited space-based assets have been used as part of the space surveillance network (SSN) to track orbital debris, inactive and active satellites alike. With the current SSN assets aging and the need for SSA growing, it is important to explore new ways to ensure proper SSA is maintained to preserve space operations. The Space-based Telescope for the Actionable Refinement of Ephemeris (STARE) project was initiated to explore the potential for a cube satellite (CubeSat) to contribute to the current SSN, with an optical payload integrated into a 3U Colony II Bus. The bus and payload data from the CubeSat will be collected by the Naval Postgraduate School Mobile CubeSat Command and Control ground station. Telemetry data from the bus will be analyzed at NPS and the payload data at Lawrence Livermore National Laboratory. This thesis outlines the concept of operation for the STARE CubeSat and investigates the possibility of using the data generated by STARE to augment the SSN to reduce the errors associated with conjunction analysis performed at the Joint Space Operations Center.				
14. SUBJECT TERMS 3U, STARE, Colony II Bus, Conjunction, CubeSat, Optical Imager, Orbital Debris Tracking, Space Situational Awareness, Space Surveillance Network.			15. NUMBER OF PAGES 87	
			16. PRICE CODE	
17. SECURITY CLASSIFICATION OF REPORT Unclassified	18. SECURITY CLASSIFICATION OF THIS PAGE Unclassified	19. SECURITY CLASSIFICATION OF ABSTRACT Unclassified	20. LIMITATION OF ABSTRACT UU	

THIS PAGE INTENTIONALLY LEFT BLANK

**Approved for public release; distribution is unlimited**

**SPACE SITUATIONAL AWARENESS CUBESAT CONCEPT  
OF OPERATIONS**

Tolulope E. O'Brien  
Lieutenant, United States Navy  
B.S., United States Naval Academy, 2005

Submitted in partial fulfillment of the  
requirements for the degree of

**MASTER OF SCIENCE IN SPACE SYSTEMS OPERATIONS**

from the

**NAVAL POSTGRADUATE SCHOOL  
December 2011**

Author: Tolulope E. O'Brien

Approved by: Alan D. Scott  
Thesis Advisor

James H. Newman  
Thesis Co-Advisor

James A. Horning  
Second Reader

Rudy Panholzer  
Chair, Space Systems Academic Group

THIS PAGE INTENTIONALLY LEFT BLANK

## **ABSTRACT**

The concept of space situational awareness (SSA) is important to preserve manned and unmanned space operations. Traditionally, ground based radar, electro-optical sensors and very limited space-based assets have been used as part of the space surveillance network (SSN) to track orbital debris, inactive and active satellites alike. With the current SSN assets aging and the need for SSA growing, it is important to explore new ways to ensure proper SSA is maintained to preserve space operations. The Space-based Telescope for the Actionable Refinement of Ephemeris (STARE) project was initiated to explore the potential for a cube satellite (CubeSat) to contribute to the current SSN, with an optical payload integrated into a 3U Colony II Bus. The bus and payload data from the CubeSat will be collected by the Naval Postgraduate School Mobile CubeSat Command and Control ground station. Telemetry data from the bus will be analyzed at NPS and the payload data at Lawrence Livermore National Laboratory. This thesis outlines the concept of operation for the STARE CubeSat and investigates the possibility of using the data generated by STARE to augment the SSN to reduce the errors associated with conjunction analysis performed at the Joint Space Operations Center.

THIS PAGE INTENTIONALLY LEFT BLANK



# TABLE OF CONTENTS

I.	INTRODUCTION.....	1
A.	SPACE SITUATIONAL AWARENESS.....	2
B.	THE SPACE SURVEILLANCE NETWORK.....	7
1.	Ground-Based Architecture.....	10
2.	Space-Based Architecture .....	11
3.	Coalition SSA Efforts .....	13
C.	NAVAL POSTGRADUATE SCHOOL SPACE SITUATIONAL AWARENESS EFFORT.....	14
D.	OVERVIEW OF CUBESATS .....	15
II.	SPACE SITUATIONAL AWARENESS (SSA) CUBESAT OVERVIEW.....	17
A.	TECHNICAL BACKGROUND .....	17
B.	PAYLOAD.....	19
C.	CUBESAT BUS.....	21
III.	PAYLOAD MISSIONS AND GOALS.....	27
A.	TECHNICAL GOALS (LLNL INPUT).....	27
B.	MISSION GOALS.....	27
IV.	SSA CUBESAT CONCEPT OF OPERATIONS (CONOPS).....	29
A.	MODE OF OPERATION .....	29
1.	Normal Mode .....	30
2.	Sun-Safe and Survival Modes.....	31
B.	POINTING CAPABILITIES .....	32
C.	COMMAND AND DATA HANDLING.....	33
D.	DATA FORMAT .....	34
E.	STORAGE AND DOWNLINK .....	34
F.	GROUND STATION ARCHITECTURE AND REQUIREMENTS .....	35
G.	TRACKING TELEMETRY AND COMMAND (TT&C) LINK.....	36
H.	DATA TRANSFER REQUIREMENTS .....	37
I.	POWER MANAGEMENT .....	37
J.	THERMAL EFFECTS ON SATELLITE.....	37
V.	DATA COLLECTION AND HANDLING ANALYSIS .....	39
A.	NPS MC3 GROUND STATION .....	40
B.	SENDING COMMANDS TO SATELLITE .....	42
C.	OBSERVATION STRATEGY OF SATELLITE .....	42
D.	RECEIVING TELEMETRY DATA FROM SATELLITE .....	44
E.	DATA THROTTLING .....	50
F.	A DAY IN THE LIFE OF STARE.....	52
1.	Initial Operations .....	52
2.	Constellation Routine Operation.....	53
F.	ANALYSIS CONCLUSION .....	55
VI.	CONCLUSION AND FUTURE WORK .....	57

A.	FUTURE WORK.....	57
1.	STARE Program Manager .....	57
2.	Further Testing of FV1 .....	57
3.	Integration and Testing .....	58
B.	STARE FUTURE EXPANSION SUGGESTIONS.....	58
C.	SUMMARY .....	59
APPENDIX A.	STARE SCIENCE GOALS.....	61
LIST OF REFERENCES.....		63
INITIAL DISTRIBUTION LIST .....		67

## LIST OF FIGURES

Figure 1.	Space Situational Awareness OV-1 (From HQ Air Force Space Command/A3CD, 2007, p. 13) .....	3
Figure 2.	Chinese ASAT test (five minutes post-attack) FENGYUN 1C and other debris (green), Pre-attack FENGYUN 1C orbital track (red) (From Kelso, 2011).....	4
Figure 3.	View of ISS Orbit (green) and Debris Ring (red) from Chinese ASAT Test (December 5, 2007) (From Kelso, 2011).....	4
Figure 4.	View of LEO Satellites (green) and Debris Ring (red) from Chinese ASAT Test (December 5, 2007) (From Kelso, 2011).....	5
Figure 5.	View of Iridium 33 and Cosmos 2251 orbits just prior to collision (From Kelso, 2009).....	6
Figure 6.	View of Iridium 33 and Cosmos 2251 orbits and debris 10 minutes post-collision (From Kelso, 2009).....	6
Figure 7.	View of Iridium 33 and Cosmos 2251 orbits and debris 180 minutes post-collision (From Kelso, 2009).....	7
Figure 8.	SSN dedicated, collateral and contributing sensor locations (AU Space Primer, 2003).....	8
Figure 9.	SBV sensor on the MSX (Stokes, Von Braun, Sridharan, Harrison, & Sharma, 1998) .....	12
Figure 10.	SBSS Concept (“Preventing a space Pearl Harbor,” 2010).....	13
Figure 11.	Sapphire System (From Maskell & Oram, 2008) .....	14
Figure 12.	STARE Satellite Configuration (From Naval Research Lab ICD, 2011. p. 1).....	15
Figure 13.	P-POD and CubeSat Structures (2U, 1U, 3U) (From Jenkins, 2010) .	16
Figure 14.	Early 3D Model of C2B with partial payload .....	17
Figure 15.	SSA STARE CONOPS (From Simms et al., 2002) .....	18
Figure 16.	SSA STARE OPTICAL PAYLOAD (NPS CAD model) .....	19
Figure 17.	C2B and LLNL Optical Payload (From Riot et al., 2011 Slide 30) .....	20
Figure 18.	Notional Mission Timeline (From NanoSat Engineering 2011, p. 56) .	21
Figure 19.	First C2B Engineering Model Version A (EM-A).....	22
Figure 20.	C2B Engineering Model Version 1 (EM-1) with Reaction Wheels Visible.....	23
Figure 21.	Data Interface and Power Board to Integrate STARE Payload to C2B (After NanoSat Engineering, 2011, Pg.40 and Riot et al., 2011 Slide 73) .....	24
Figure 22.	C2B Engineering Model Umbilical Box and Cable.....	24
Figure 23.	C2B Flight Unit in Transport Structure.....	25
Figure 24.	Depiction of umbra and full sunlight (From Flanagan 2010, Pg 13)....	28
Figure 25.	C2B Modes of Operation (After NanoSat Engineering, 2011, p. 52) ..	29
Figure 26.	Sidereal Track (From HQ Air Force Space Command/A3CD, 2007, p. 124) .....	32

Figure 27.	Top-Level Ground Station Operations Architecture (Arnold, Johnson & Davis, 2011, Slide 4) .....	35
Figure 28.	Electrical Ground Support Equipment (From Riot et al., 2011b, p. 6).	39
Figure 29.	C2B Engineering Model (EM-1), umbilical box and cable.....	40
Figure 30.	Simulated image for an Iridium 16 conjunction (From Riot, Olivier, Perticia, Bauman, Simms, & De Vries, 2010 p. 59) .....	44
Figure 31.	SBV raw full-frame CCD exposure and (b) an associated signal processor image. (From Stokes et al., 1998).....	50
Figure 32.	STARE FOV in Steradians .....	55

## LIST OF TABLES

Table 1.	SSN Sensor Overview (Data derived from HQ Air Force Space Command/A3CD, 2007) .....	10
Table 2.	SSN Dedicated Sensors (Data derived from HQ Air Force Space Command/A3CD, 2007) .....	10
Table 3.	SSN Collateral Sensors (Data derived from HQ Air Force Space Command/A3CD, 2007) .....	11
Table 4.	SSN Contributing Sensors (Data derived from HQ Air Force Space Command/A3CD, 2007) .....	11
Table 5.	Imager specification (After Riot, Olivier, Perticia, Bauman, Simms, & De Vries, 2011a, p. 22) .....	20
Table 6.	C2B Normal Mode of Operation (Data derived from NanoSat Engineering 2011) .....	30
Table 7.	Sun-Safe and Survival Modes of Operation (Data derived from NanoSat Engineering 2011) .....	31
Table 8.	Characteristics of the C&DH Module (From NanoSat Engineering, 2011, p. 13) .....	33
Table 9.	MC3 Ground Station Locations (Data derived from Griffith, 2011, p. 36) .....	36
Table 10.	STARE Year Long Access to MC3 Ground Stations .....	41
Table 11.	Daily Average Access Data for STARE to Ground Stations .....	41
Table 12.	Payload Data Groups (After NanoSat Engineering 2011, p. 43) .....	45
Table 13.	TLM data with 10 Observations + 1 Raw Image File Scenario (Data from Boeings C2B Command Telemetry Database).....	46
Table 14.	TLM with no raw image in the STARE serial data group (Data derived from Boeing's C2B Command Telemetry Database Version 7.1) .....	47
Table 15.	Daily access time from STARE to NPS ground station.....	47
Table 16.	STARE data rate calculation .....	48
Table 17.	TLM data with one second storage rate (Data from Boeing's C2B Command Telemetry Database).....	49
Table 18.	Data throttling parameters .....	51
Table 19.	Percentage of sky the payload can image based on FOV .....	55
Table 20.	STARE Science Goals (From Riot, Olivier, Perticia, Bauman, Simms, & De Vries, 2011a, p. 10) .....	61

THIS PAGE INTENTIONALLY LEFT BLANK

## LIST OF ACRONYMS AND ABBREVIATIONS

1.5U	One and a Half Unit Cube Satellite
3U	Three Unit Cube Satellite
ADCNS	Attitude Determination, Control and Navigation System
AFSSS	Air Force Space Surveillance System
ASAT	Anti Satellite
ASCC	Alternate Space Control Center
BMEWS	Ballistic Missile Early Warning System
bps	Bits per second
Bps	Bytes per second
C2	Command and Control
C2B	Colony II Bus
C&DH	Command and Data Handling
CCITT	International Telegraph and Telephone Consultative Committee
CGA	Common Ground Architecture
CONUS	Continental United States
CSSS	Canadian Space Surveillance System
DIP	Data, Interface and Power
DND	Department of National Defense
EGSE	Electrical Ground Support Equipment
EM	Engineering Model
EO	Electro Optical
FV	Flight Vehicle

FOV	Field of View
GEODSS	Ground-based Electro-Optical Deep Space Surveillance
LEO	Low Earth Orbit
JMS	JSpOC Mission System
JSpOC	Joint Space Operations Center
LLNL	Lawrence Livermore National Laboratory
MC3	Mobile CubeSat Command and Control
MOSS	Moron optical Space Surveillance
MSSS	Maui Space Surveillance System
MSX	Midcourse Space Experiment
NASIC	National Air and Space Intelligence Center
OCONUS	Outside the Continental United States
OPCON	Operational Control
OV-1	Operational Viewpoint (High-level operational concept graphic)
PAVE PAWS	PAVE Phased Array Warning System
PARCS	Perimeter Acquisition Radar Characterization
RAF	Royal Canadian Air Force
RSO	Resident Space Object
RTS	Ronald Reagan Test Site
SBSS	Space Based Space Surveillance
SBV	Space-Based Visible
SMILE	STARE Mission Hardware in the Loop Environment
SOC	Satellite Operations Center
SOH	State-Of-Health



SOI	Space Object Identification
SofS	Surveillance of Space
SPCS	Space Control Squadron
sr	Steradian
SS	Sun-Safe
SSA	Space Situational Awareness
SSAG	Space Systems Academic Group
SSN	Space Surveillance Network
SSOC	Sensor System Operations Center
STARE	Space Telescope for the Actionable Refinement of Ephemeris
STK	Systems Took Kit
SWS	Space Warning Squadron
TAMU	Texas A&M University
TEARR	Time, Elevation, Azimuth, Range and Range Rate
TT&C	Tracking, Telemetry, and Command
U-Box	Umbilical Box
USAF	United States Air Force
USSTRATCOM	United States Strategic Command
UTJ	Ultra Triple Junction

THIS PAGE INTENTIONALLY LEFT BLANK

## ACKNOWLEDGMENTS

This thesis would not have been possible without the assistance and support of my advisors, CAPT Alan Scott and Dr. James Newman. Their experience and guidance made it possible for me to succeed at NPS. They gave me room to grow and guidance when I strayed to ensure success in my endeavors. Mr. James Horning spent countless hours going over software protocol and his input to the project was invaluable. I appreciate his patience in explaining software protocol and the many hours we spent in the lab. Mr. David Rigmaiden's technical expertise with lab equipment and Mr. Dan Sakoda's extensive knowledge of STK eased the workload and saved many hours of working through problems. I would also like to thank the members of the LLNL for their efforts throughout the project and assistance in helping me complete this thesis.

Working with the "MTV Rev A" – (Madison, Tolu, Vidal and Ashley) made this adventure enjoyable. LT Vidal Lozada, Miss Madison Studholme and Ms. Ashley Dittberner made the project memorable. The talented members of the NPS STARE team lifted my spirits and provided a comfortable environment to learn and laugh—a necessary combination when working on a challenging task. LT Lozada's engineering knowledge and naval experience was an asset to the team. Madison's enthusiasm for space systems was contagious and Ashley's test engineer experience helped streamline the test process. Working with you was a joy.

I would like to thank my parents, Eunice and Oluwole Alade. My mom's unconditional love, guidance, emotional and spiritual support throughout my life has shaped me into the person I am today. She is my role model and I admire her achievements and strength. My father instilled a sense of discipline and dedication that I have continuously called upon, especially in the final stages of this project. My father-in-law, James O'Brien Sr., provided much needed stress

relief and his interest in my work encouraged me to excel. The support of my mothers-in-law, Patricia Holtmeyer and Luella O'Brien, aided me greatly by taking care of my children during critical times, enabling me to focus as needed on my thesis and finals.

Lastly, I would like to thank my husband, Capt. James O'Brien Jr. Your love, support and patience throughout the past few years at NPS have allowed me to achieve this great accomplishment. We came here with a dog and now we are leaving with our beautiful daughter, Madison Marie, our precious son, Cannon James McKinley, our adopted daughter, Pamela, a true sweetheart, two master's degrees, language training in Pashto and partnership in a small business. We even launched our first combat nutrition product, *RuckPack*, during this time. We truly have made the most of this duty station! I love you and I look forward to our next adventure together.

Most importantly, I would like to thank God, through whom all things are possible.

## I. INTRODUCTION

Several events in recent history have compounded the orbital debris problem jeopardizing operations in space. On January 19, 2007, China conducted its first successful direct-ascent anti-satellite (ASAT) SC-19 missile test against a Fengyun-1C weather satellite at about 850 km in space. This resulted in approximately 850 pieces of orbital debris greater than four inches and thousands of smaller pieces (Kan, 2007, p. CRS 1–2). Another notable event was the collision of an inactive Cosmos 2251 with an active Iridium 33 communications satellite February 10, 2009, that resulted in over 2000 pieces of orbital debris. The effects of the collision range in altitude from 200 km to 1700 km with a large concentration of debris at 800 km. A large number of spacecraft perform communications and Earth observation mission within this range (Liou & Shoats, 2009).

With the space environment in low earth orbit (LEO) becoming congested, contested and competitive, the need to come up with a solution to address how countries can operate effectively in space is paramount. The need for improved Space Situational Awareness (SSA) has gained international focus in light of recent events and the question of innovative ways to address the orbital debris problem in space is the basis of this thesis. The United States Space Surveillance Network (SSN) currently tracks 22,000 orbiting objects larger than 10 cm including over 1,100 active satellites, and the numbers are trending upwards (USSTRATCOM Space Control and Space Surveillance, 2010). In order to provide better conjunction analysis data to guide operations in space an experimental optical payload will be integrated on a cube satellite (CubeSat) and launched into LEO. If this pathfinder experiment is successful, a constellation of CubeSats could be launched and data from the constellation analyzed and eventually fed into the SSN to decrease the uncertainty associated with current conjunction analysis performed at the Joint Space Operations Center (JSpOC) by the JSpOC Mission System (JMS).

## **A. SPACE SITUATIONAL AWARENESS**

The all-encompassing definition of SSA is “the requisite current and predictive knowledge of space events, threats, activities, conditions, and space system (space, ground link) status, capabilities, constraints and employment—current and future, friendly and hostile—to enable commanders, decision makers, planners, and operators to gain and maintain space superiority across the spectrum of conflict” (HQ Air Force Space Command/A3CD, 2007). As it applies to real-world operations, SSA “provides the battlespace awareness required for planning, executing, and assessing protection of space assets, prevention of hostile actions, and negation of hostile resources in all mediums” (HQ Air Force Space Command/A3CD, 2007). SSA does not stand alone in its function but is comprised of intelligence, surveillance, reconnaissance (ISR), environmental monitoring and command and control (C2) components. The idea of SSA gained ground and came to the forefront of U.S. space policy after both intentional and unintentional collisions in space causing a dramatic increase in orbital debris. Figure 1 provides a broad overview of SSA at the strategic, operational and tactical levels of C2.



Figure 1. Space Situational Awareness OV-1 (From HQ Air Force Space Command/A3CD, 2007, p. 13)

The Chinese direct ascent ASAT SC-19 missile test conducted January 19, 2007, against a Fengyun-1C weather satellite at an altitude of about 850 km in space created an orbital debris cloud hazardous to manned and unmanned space operations. As of May 11, 2011, NORAD had catalogued 3,135 pieces of debris including the remnants of the original payload (Kelso, 2011). There is an upward trend in the contribution of orbital debris from this incident when compared to 3,037 orbital debris pieces reported by NASA in mid-September 2010 and the initial estimates of over 2000 pieces, which does not bode well for operations in LEO (Liou & Shoots, 2010). The missile test orbital debris accounts for approximately 22% of all debris cataloged and tracked by the SSN. Effects of the collision from minutes after the collision to the present are depicted in Figures 2 - 4. In Figure 2, the green dots show the effects of the collision five minutes post attack and the cluster of debris that formed compared to the FENGYUN 1C

pre-attack orbital track shown in red. Figure 3 and Figure 4, 11 months post-event, show the dispersal effects of the debris ring and the potential impact it has on operational satellites at LEO.

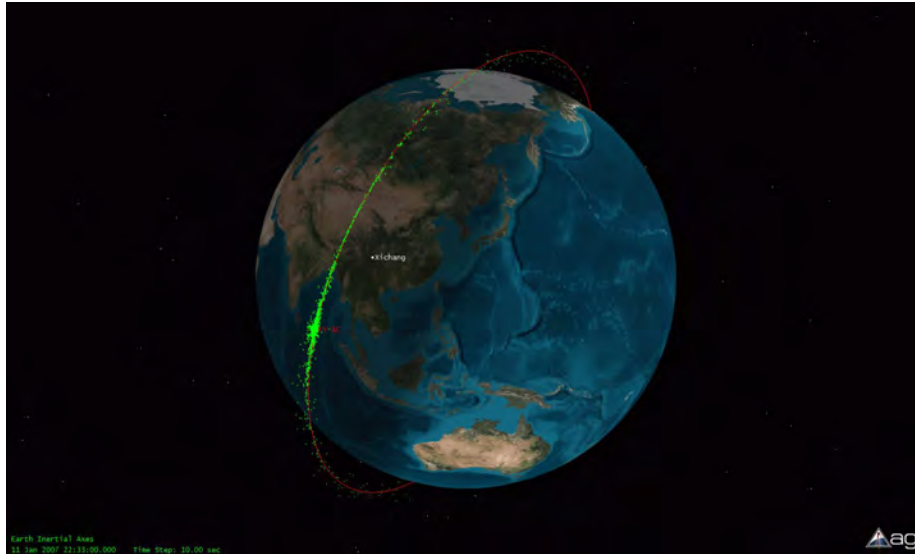

Figure 2. Chinese ASAT test (five minutes post-attack) FENGYUN 1C and other debris (green), Pre-attack FENGYUN 1C orbital track (red) (From Kelso, 2011)

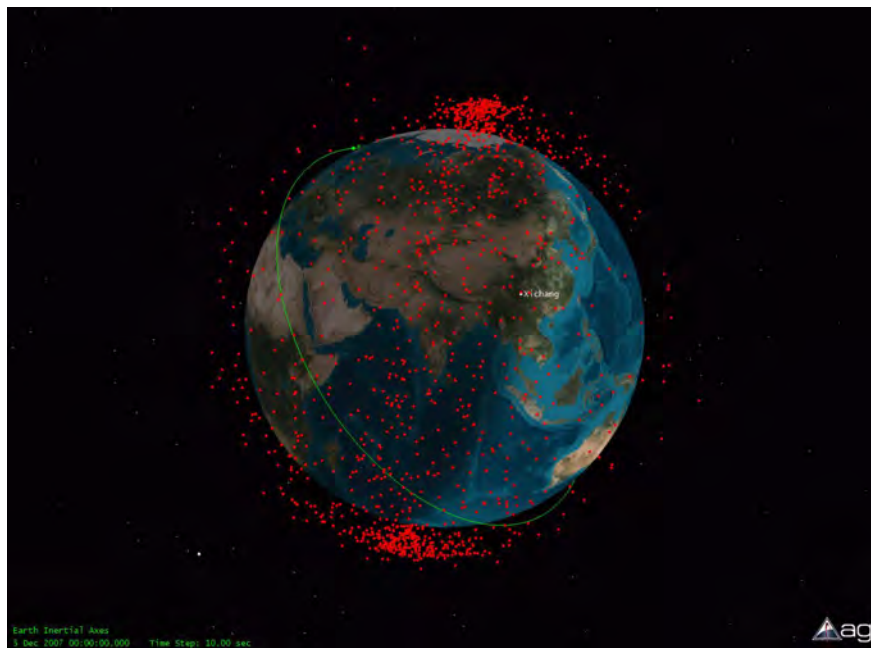

Figure 3. View of ISS Orbit (green) and Debris Ring (red) from Chinese ASAT Test (December 5, 2007) (From Kelso, 2011)



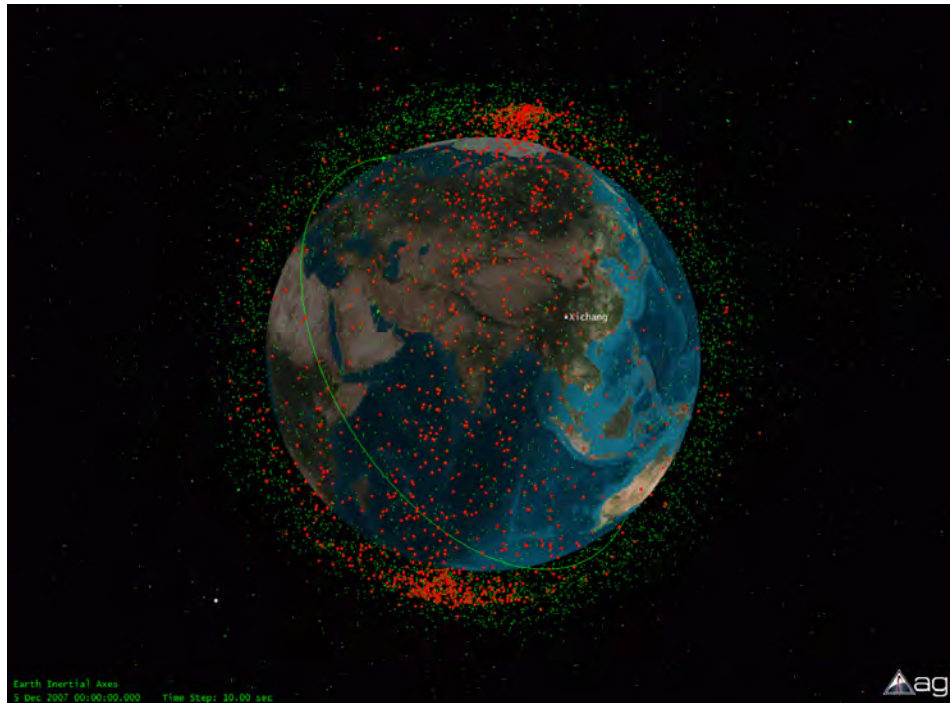

Figure 4. View of LEO Satellites (green) and Debris Ring (red) from Chinese ASAT Test (December 5, 2007) (From Kelso, 2011)

The year 2009 was marked by the collision of the spent COSMOS 2251 with the active Iridium 33 communications satellite. This was the first recorded incident of an accidental collision involving two intact satellites in space challenging the “big space” theory. The overall contribution of orbital debris to LEO from this collision was over 2000 pieces. The collision occurred above the International Space Station (ISS) orbit (325km), at approximately 790km in altitude. While the effects of the collision were catastrophic to the active satellite, the impact on manned space operation is assessed to be low, however as the debris descends, the impact to operational satellites is moderate to high (Iannotta & Malik, 2009). Effects from the collision have led to a push for more accountability concerning satellite ownership. Space traffic growth since 1980 when only 10 countries were operating satellites in space, to the present day when “nine countries operate spaceports, more than 50 countries own or have partial ownership in satellites and citizens of 39 nations have traveled to space” is a source of challenge and concern. (Keeping the Space Environment Safe for

Civil and Commercial Users, 2009). Figure 5 shows the orbital track of both Iridium 33 and Cosmos 2251 prior to the collision. Figure 6 and Figure 7 show the post collision track and the associated orbital debris created from the collision 10 and 180 minutes later.

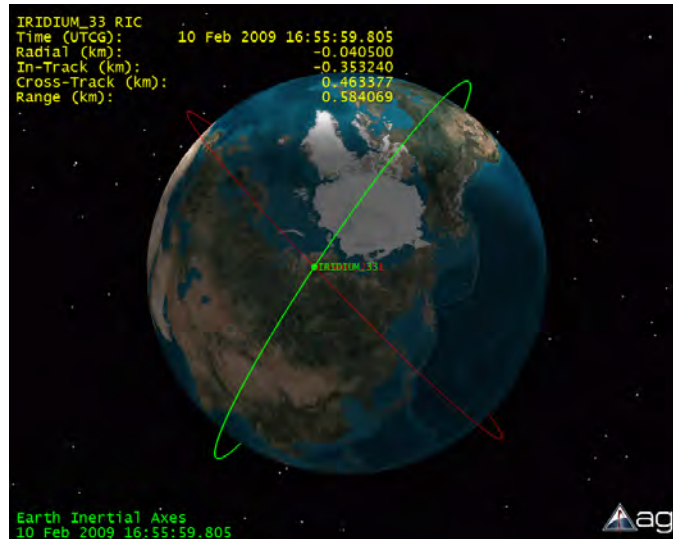

Figure 5. View of Iridium 33 and Cosmos 2251 orbits just prior to collision (From Kelso, 2009)



Figure 6. View of Iridium 33 and Cosmos 2251 orbits and debris 10 minutes post-collision (From Kelso, 2009)

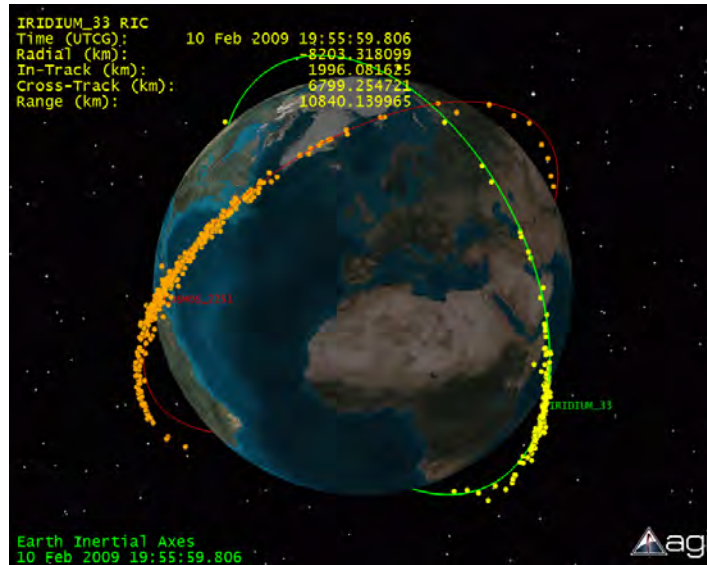

Figure 7. View of Iridium 33 and Cosmos 2251 orbits and debris 180 minutes post-collision (From Kelso, 2009)

## B. THE SPACE SURVEILLANCE NETWORK

The United States Air Force began the space surveillance mission in 1956 with the development of the Baker-Nunn Optical Satellite Tracking Cameras. The history of collaboration between the USAF, the Royal Canadian Air Force (RAF) and the Smithsonian Institution Astrophysics Observatory has evolved dramatically with the initial network comprising 15 sites with Baker-Nunn cameras to the current network with radar and electro optical sensors at 27 sites along with the space based space surveillance satellite. The initial sensors were designed to track man-made objects in space with the first successful object tracked being Sputnik I on October 17, 1957. The mission has changed dramatically to cover missile detection and warning from the Soviet Union in the 1970s to the detection and tracking of resident space objects (RSO) above 10cm in diameter from the 1990s to present. The evolution of the network included development of the Millstone Radar and the Navy space surveillance fence, now known as the Air Force Space Surveillance System (AFSSS). Figure 8 shows

the dedicated, collateral and contributing sensors of the SSN as of 2003. However, the AFSSS and the space based surveillance assets are not reflected in the figure.



Figure 8. SSN dedicated, collateral and contributing sensor locations (AU Space Primer, 2003)

The current SSN is comprised of both ground and space based assets. Its primary function is to gather two main types of data “to detect, track, identify, characterize, catalog and monitor man-made objects in space” (HQ Air Force Space Command/A3CD, 2007). The first is Metric Time, Elevation, Azimuth, Range and Range Rate (TEARR) data used to provide information on foreign and domestic catalogued objects, and is extremely effective in determining space objects’ current and future orbital position. The second main type of data gathered is called space object identification (SOI) data, which is used to help identify if the space object being tracked contains a payload and if there are any changes to the satellite’s configuration while in orbit. Both primary and collateral sensors dedicated to gather this form of intelligence are scattered throughout the globe, mainly in the continental United States (CONUS) with additional sites

outside the continental United States (OCONUS). OCONUS sites include Spain, British Indian Ocean Territory, Norway, Greenland, United Kingdom, and Ascension Island.

To understand how the space surveillance assets are tasked and how their functions are assigned, it is pivotal to understand the command and control (C2) and organizational hierarchy of the SSN. In particular, it is important to recognize the difference between a dedicated, collateral or contributing sensor of the SSN. “Dedicated sensors are USSTRATCOM subordinate sensors with a primary mission of SSN support. Collateral sensors are sensors that are subordinate to USSTRATCOM but with a primary mission other than SSN support. Contributing sensors are non-USSTRATCOM sensors under contract or agreement to support the SSN” (HQ Air Force Space Command/A3CD, 2007). SSN sensors are summarized in Table 1. The SSN has three C2 centers located across the United States: The Joint Space Operations Center Space Situational Awareness Operations Cell (JSpOC SSA Ops Cell) in Vandenberg, CA, the Alternate Space Control Center (ASCC) in Dahlgren, VA and the National Air and Space Intelligence Center (NASIC) located at Wright Patterson AFB, OH. Table 1 provides an overview of all the ground and space-based dedicated, collateral and contributing sensors associated with the SSN. Table 2, Table 3 and Table 4 give a breakdown of the SSN ground-based architecture. The sensors are further broken down based on their role as per how they are used as part of the SSN, the type of sensor they are and their capabilities.

Dedicated Sensors	Collateral Sensors	Contributing Sensors
USSTRATCOM sensors with primary mission of space track	USSTRATCOM sensor with primary mission other than space track e.g. Missile Warning	Non-USSTRATCOM sensors under contract for SSN support
Ground-based Electro-Optical Deep Space Surveillance (GEODSS)	Ballistic Missile Early Warning Systems (BMEWS)	LSSC – Milestone / Haystack / Haystack Aux
Moron Optical Space Surveillance (MOSS) System	12th Space Warning Squadron (SWS), Thule	RTS – ALTAIR / ALCOR / TRADEX / MMW
Air Force Space Surveillance System (AFSSS) aka Space Fence	13th SWS, Clear	Maui Space Surveillance System (MSSS)
20 space Control Squadron (SPCS), Eglin	Fylingdales	Shemya’s Cobra Dane
Globus II	PAVE Phased Array Warning System (PAVE PAWS)	
Space Based Space Surveillance (SBSS) Block 10	7 SWS, Beale	
	6 SWS, Cape Cod	
	Perimeter Acquisition Radar Characterization (PARCS)	
	Ascension Radar	

Table 1. SSN Sensor Overview (Data derived from HQ Air Force Space Command/A3CD, 2007)

**1. Ground-Based Architecture**

Sensor Site	Description	Capabilities
Sensors	Fence	Near Earth/Deep Space
Diego Garcia GEODSS	Optical	Deep Space
Eglin AFB PAVE PAWS	Phased Array	Near Earth/Deep Space
Globus II X-Band	Mechanical	Near Earth/Deep Space
Maui GEODSS	Optical	Deep Space
MOSS	Optical	Deep Space
Socorro GEODSS	Optical	Deep Space

Table 2. SSN Dedicated Sensors (Data derived from HQ Air Force Space Command/A3CD, 2007)

Sensor Site	Description	Capabilities
Ascension Island Radar Tracking Station	Mechanical	Near Earth
Beale AFB PAVE PAWS	Phased Array	Near Earth
Cape Cod AFB PAVE PAWS	Phased Array	Near Earth
Cavalier AFB PARCS	Phased Array	Near Earth
Clear AFB BEMWS	Phased Array	Near Earth
Fylingdale Royal AFB BEMWS	Phased Array	Near Earth
Thule AFB BEMWS	Phased Array	Near Earth

Table 3. SSN Collateral Sensors (Data derived from HQ Air Force Space Command/A3CD, 2007)

Sensor Site	Description	Capabilities
Cobra Dane (Shemya)	Phased Array	Near Earth
Millstone L-Band	Mechanical	Near Earth/Deep Space
Millstone UHF		
Haystack LRIR Haystack Auxiliary	Mechanical	Near Earth/Deep Space
MSSS AEOS/RAVEN/Motif/BDTs	Optical	Deep Space
Ronald Reagan Test Site (RTS) Altir (ALT) / Tradex (TDX)	Mechanical	Near Earth/Deep Space
Ronald Reagan Test Site (RTS) ALCOR (ALC) /MMW	Mechanical	Near Earth/Deep Space

Table 4. SSN Contributing Sensors (Data derived from HQ Air Force Space Command/A3CD, 2007)

## 2. Space-Based Architecture

The original space-based space surveillance (SBSS) system was the Space Based Visible (SBV) payload on the Midcourse Space Experiment (MSX) satellite, as seen in Figure 9. SBV was an electro-optical (EO) camera payload on the MSX. The satellite was launched in 1996 and was operationally used as a contributing sensor of the space surveillance network in 1998 after successful completion of the technology demonstration phase. SBV was used actively in support of the SSN until June 2010 when it was decommissioned. The satellite was used years past its design life and the EO payload served as a starting point for follow-on systems.

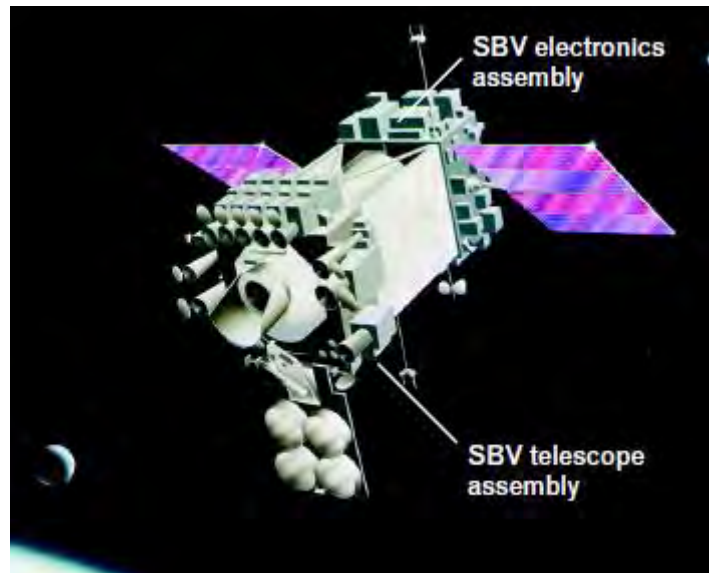

Figure 9. SBV sensor on the MSX (Stokes, Von Braun, Sridharan, Harrison, & Sharma, 1998)

The follow-on system to SBV/MSX is the SBSS Block 10, the next generation of space-based monitoring asset. Block 10 was launched September 25, 2010, and completed on-orbit testing December 23, 2010. With the upgrades incorporated in block 10, it will be “twice as sensitive, twice as fast at detecting threats, [with] three times the improvement in the probability of detecting threats and ten times improvement in capacity” over SBV/MSX. (Ball, 2011). The SBSS concept, in Figure 10, was designed with the intent to provide DoD as well as NASA information on space objects being detected and tracked. Currently SBSS is the only space-based asset that is part of the SSN. Block 10 was constructed as the pathfinder for the follow-on system, Block 20. SBSS Block 20 was designed to be a four-satellite constellation. However, due to the current fiscal constraints, the program has been canceled. Cancellation of the program will leave a gap in the space-based component of the SSN, which leads one to question how the United States intends to fill the gap. Possible solutions to filling this gap will be using coalition assets like the Canadian Sapphire satellite or by using CubeSats like the Space Based Telescope for the Actionable Refinement of Ephemeris (STARE).



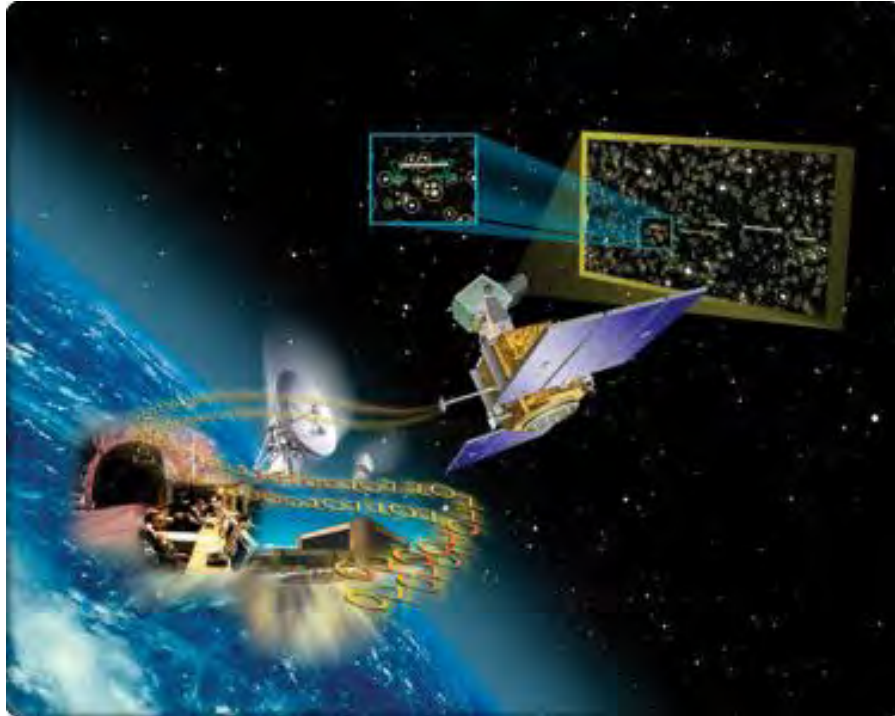

Figure 10. SBSS Concept (“Preventing a space Pearl Harbor,” 2010)

### 3. Coalition SSA Efforts

With the dramatic growth of user countries with satellites in space, it is important to include coalition partners and members of the international community in the SSA effort. It is in the interest of everyone involved and those with a stake in space, to do their part to protect operations in space. That makes SSA everyone’s problem and not just a challenge for the United States government. Especially with the growth of the commercial sector’s use of space, the private sector should also be involved in SSA efforts.

The Canadian Department of National Defense (DND) is developing the Canadian Space Surveillance System (CSSS) with the primary focus being the Surveillance of Space (SofS). The CSSS will comprise a space segment, the Sapphire satellite, and its corresponding ground segment, the Sensor System Operations Center (SSOC) as illustrated in Figure 11. The Canadian Sapphire satellite was scheduled for a July 2011 launch. However, due to delays in India’s

launch manifest, the satellite launch has been postponed to the second quarter of 2012 and could be pushed back further (Boucher, 2011). The autonomous spacecraft will eventually be integrated into the SSN and used as a contributing sensor. This will bring the number of the SSN space based surveillance assets to two.

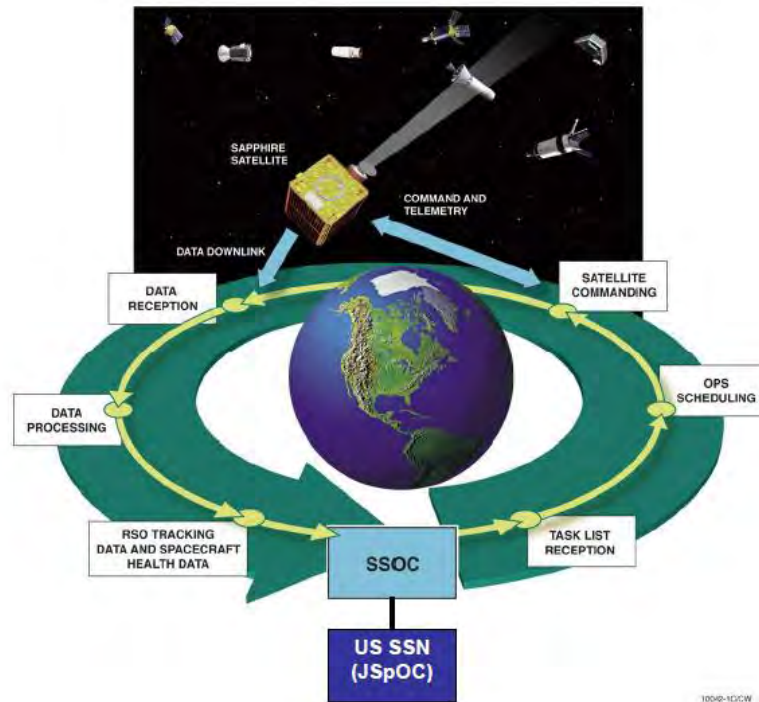

Figure 11. Sapphire System (From Maskell & Oram, 2008)

### C. NAVAL POSTGRADUATE SCHOOL SPACE SITUATIONAL AWARENESS EFFORT

Lawrence Livermore National Laboratories (LLNL), in conjunction with NPS and Texas A & M (TAMU), is working on a project to design and build a cube satellite payload that will be used for the express purpose of SSA. An optical payload designed by LLNL will be integrated into the Colony II Bus (C2B), a 3U CubeSat designed by Boeing and shown in Figure 12. It is planned that NPS and TAMU will be responsible for the integration of the payload and testing

of the Space-based Telescope for the Actionable Refinement of Ephemeris (STARE) CubeSat. The bus and payload data from the CubeSat will be collected by the NPS Mobile CubeSat Command and Control (MC3) ground station. Telemetry data from the bus will be analyzed at NPS and the payload data at LLNL. Graduate students in the Space Systems Academic Group (SSAG) engineering and operations curricula are working on the project as part of their master's theses.

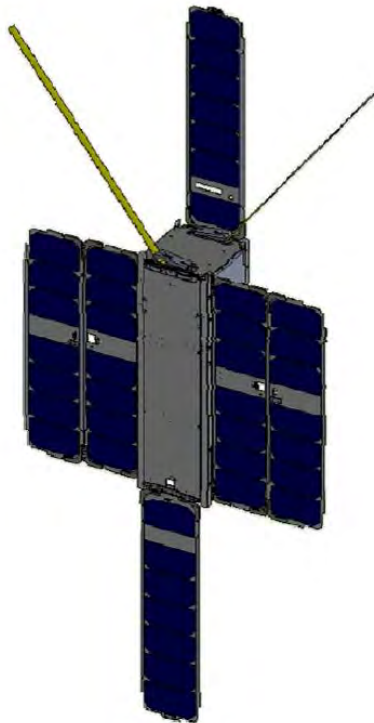

Figure 12. STARE Satellite Configuration (From Naval Research Lab ICD, 2011. p. 1)

#### **D. OVERVIEW OF CUBESATS**

The CubeSat form factor serves as a low-cost alternative to launch a payload into space. From left to right, Figure 13 shows a Poly Picosatellite Orbital Deployer (P-POD), a CubeSat integrated into a P-POD and 2U, 1U and 3U form factor CubeSats. The increasing use of CubeSats has revolutionized

access to space making it easier to launch experimental payloads and increasing our understanding of the space environment. The 3U Colony II CubeSat will be integrated into a California Polytechnic State University (Cal Poly) P-Pod, which will in turn be integrated into the Naval Postgraduate School CubeSat Launcher (NPSCuL).



Figure 13. P-POD and CubeSat Structures (2U, 1U, 3U) (From Jenkins, 2010)

## II. SPACE SITUATIONAL AWARENESS (SSA) CUBESAT OVERVIEW

### A. TECHNICAL BACKGROUND

In December 2010, NPS received one of only two C2B “preliminary” engineering models (EM) ever built. NPS SSAG students in the engineering and operations curricula as well as staff members worked on the EM in preparation for receiving the “real” engineering models. Work has been done to understand the C2B bus modes of operation to include the software protocol and payload integration. Three dimensional (3D) polycarbonate models of the C2B and payload, shown in Figure 14 have been printed and assembled to give students an understanding of integration issues and challenges. Working alongside the software engineer has also given master’s students an insight to the complexities of the C2B and STARE language protocol.



Figure 14. Early 3D Model of C2B with partial payload

Figure 15 graphically depicts the overall STARE concept of operation (CONOPS) and gives a general overview of how it refines potential conjunctions. The pathfinder phase of the STARE program will employ two CubeSats to demonstrate the feasibility of refining conjunction analysis. The overall goal is to reduce the position uncertainty of tracked objects by an order of magnitude, from about 1 kilometer down to 100 meters. If successful, the number of false alarms will be reduced by a factor of 100, the diminished uncertainty of the area of the tracked objects, or from about ten false alarms per day to one in ten days.

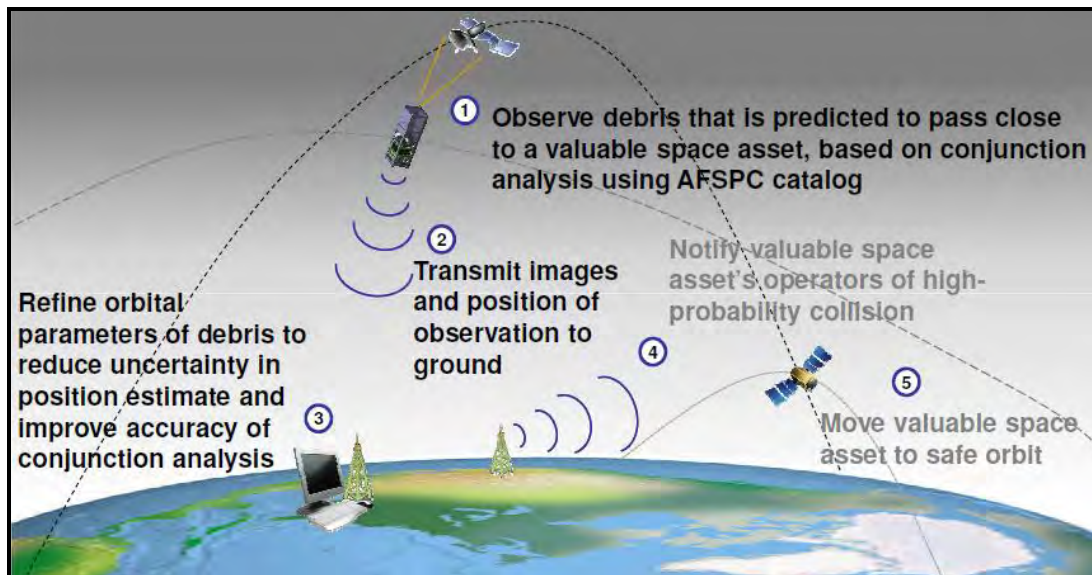

Figure 15. SSA STARE CONOPS (From Simms et al., 2002)

During phase 1, the satellite will observe debris that is predicted to pass close to a valuable space asset based on conjunction analysis using the orbital debris catalogue managed by Air Force Space Command. The satellite will transmit the images and position of the observations to the ground station in phase 2. In phase 3 of the operations, the ground station will refine the orbital parameters of the debris to reduce the uncertainty in position estimates. Reduction of the positional uncertainty inherently improves the accuracy of the conjunction analysis. Phase 4 and phase 5 are outside the scope of the satellite's mission, but they include informing the owners of the valuable space

assets of the high probability of collision and finally moving the valuable space asset to a safe orbit. The last two phases are the desired outcome based on the success of phase 1 to phase 3.

## **B. PAYLOAD**

The optical payload was designed and built by LLNL. Figure 16 shows the C2B with the payload filling up approximately 1.5U of the bus volume. The optical tracking payload is designed to acquire images of small orbiting objects, pre-process the data relevant to the target's orbit and pass the processed data to the ground station via the communication system.



Figure 16. SSA STARE OPTICAL PAYLOAD (NPS CAD model)

A detailed view of the payload shows the two-mirror telescope design, the location of the imager board, Global Positioning System (GPS) board, GPS antenna and the interface board. The interface board was developed at NPS to connect the STARE payload to the Colony II Bus. The 1.5U payload was designed to fit into the space allotted shown in Figure 17.

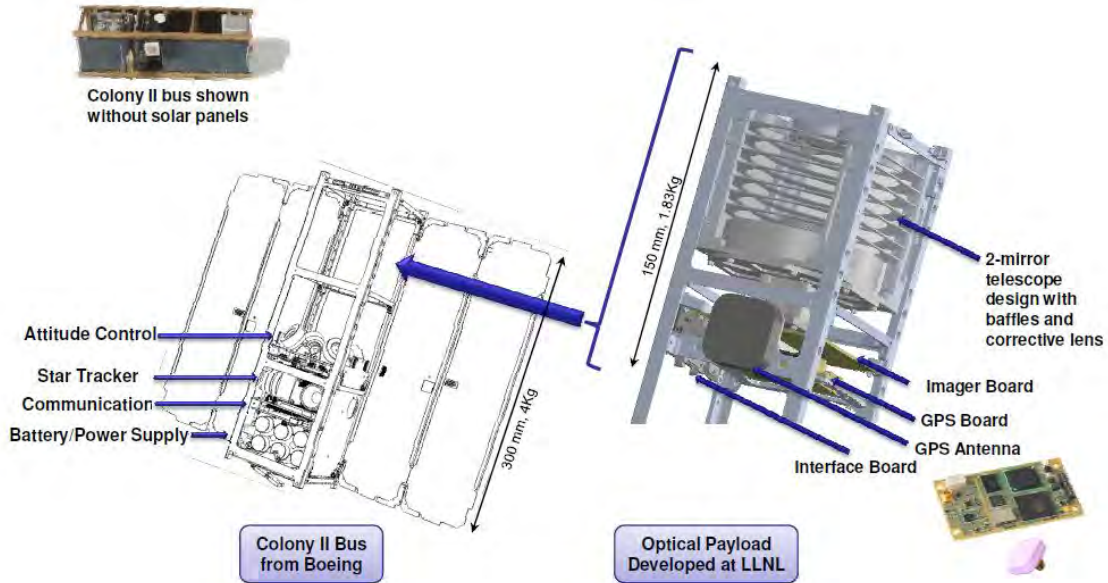

Figure 17. C2B and LLNL Optical Payload (From Riot et al., 2011 Slide 30)

The space based telescope specifications are listed in Table 5. The LLNL imaging system has a processing board, camera and optics comprised of a two-mirror telescope with corrector lens. The payload is used to image targets less than or equal to 300 km in distance traveling at a speed equal to or less than 3 km/s.

Imager Specification	Specification Value
Number of Pixels	1280x1024
Focal Length	225 mm
Field of View	2.08x1.67 degree
Pixel Size	6.7 $\mu\text{m}$
Readout Resolution	8 bits
Exposure Time	1 s
Aperture	85 mm
Optics F#	2.65
Dimension	< 9.75x9.75x15 cm
Mass	< 1.83 Kg
Output Data Rate	< 50 kbp

Table 5. Imager specification (After Riot, Olivier, Perticia, Bauman, Simms, & De Vries, 2011a, p. 22)



### C. CUBESAT BUS

The mean mission duration of STARE is six months and the design life is 12 months. The mission in this case will be limited by the bus's performance on orbit, atmospheric drag and the harsh environment at LEO. Figure 18 shows a notional timeline for the C2B from launch to when it re-enters from natural orbit decay. The Boeing's C2B is a follow on to Pumpkin's Colony I Bus in terms of size. However, the C2B is designed to provide better performance. Its goal is to function as a "plug-and-play" platform for different payloads. There are currently no flight data on the C2B as this is the first iteration of spacecraft to be used operationally. The first iteration of the C2B is scheduled to launch mid 2012 barring unforeseen problems associated with development, integration and testing.

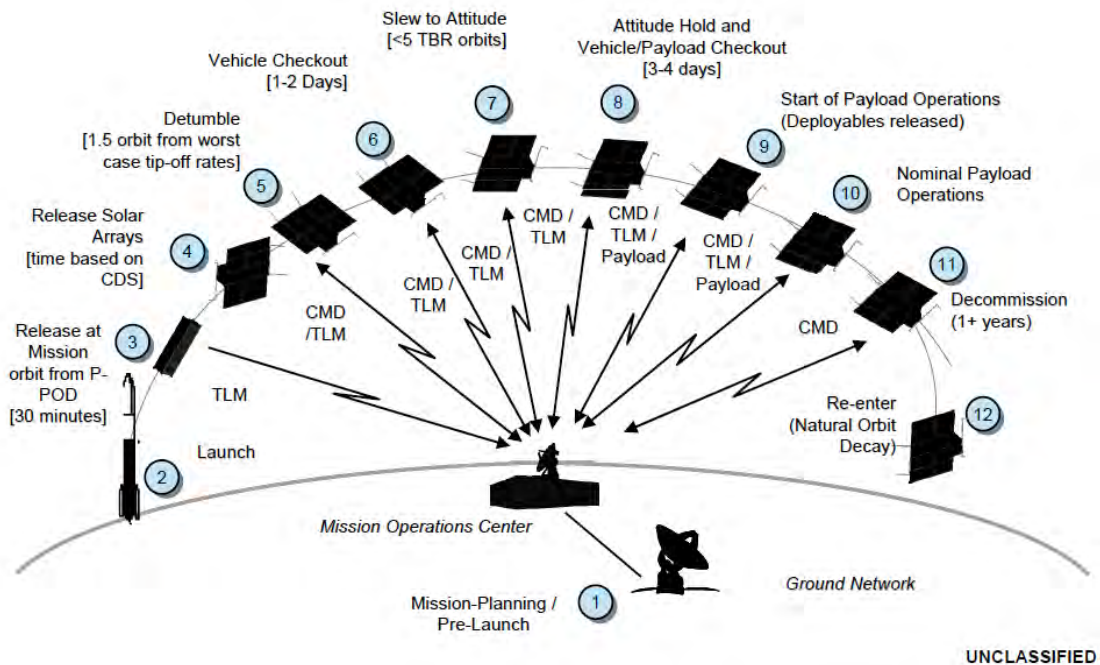

UNCLASSIFIED

Figure 18. Notional Mission Timeline (From NanoSat Engineering 2011, p. 56)

Working with the very first C2B engineering model (EM) has posed several challenges. The preliminary EM consisted of a frame and two boards,

the power board and the EPIC pictured in Figure 19. The EPIC in the first version of the EM was a stripped down model, but it provided an initial platform for testing commands for further software development. The follow-on model consists of a processing board and camera. The most significant challenge was the software protocol used by the system and inadequate documentation for how to operate the EM. Working alongside the software engineer at NPS has given space systems operations and engineering masters' students an opportunity for some hands-on opportunity, further enhancing the learning experience. Even though working with Boeing software professionals has proved challenging due to the distance and difficulties associated with sharing proprietary information, the STARE team has made progress in working and documenting advances made with the software language protocol.

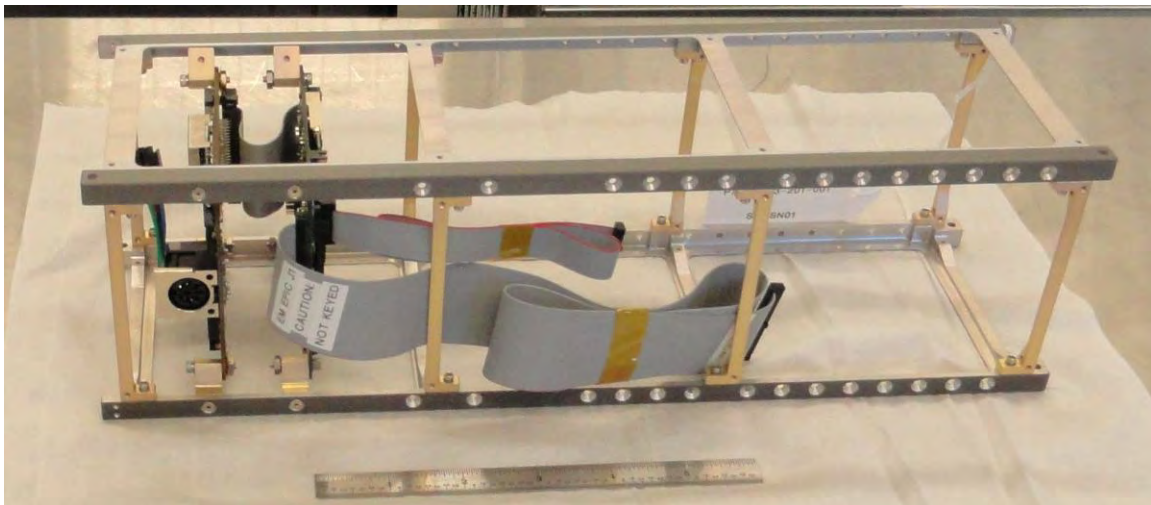

Figure 19. First C2B Engineering Model Version A (EM-A)

An upgraded version of the EM, version-1 (EM-1) pictured in Figure 20 was delivered to NPS September 2011. This version of the EM has more of the bus components than the earlier version such as the power management system and attitude determination and control system. The software used for testing was also an upgraded version of the previous module giving the software

engineer more autonomy to send commands to the spacecraft and receive telemetry data. Like the earlier version of the software, there were challenges to work through.

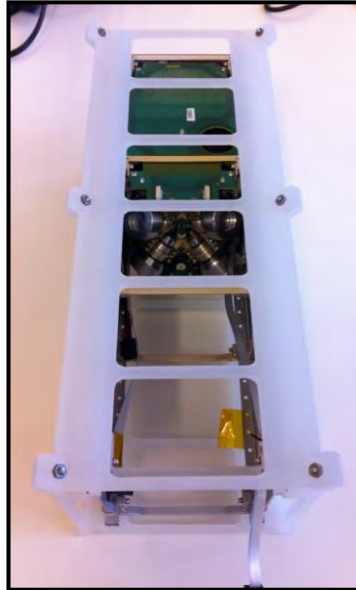
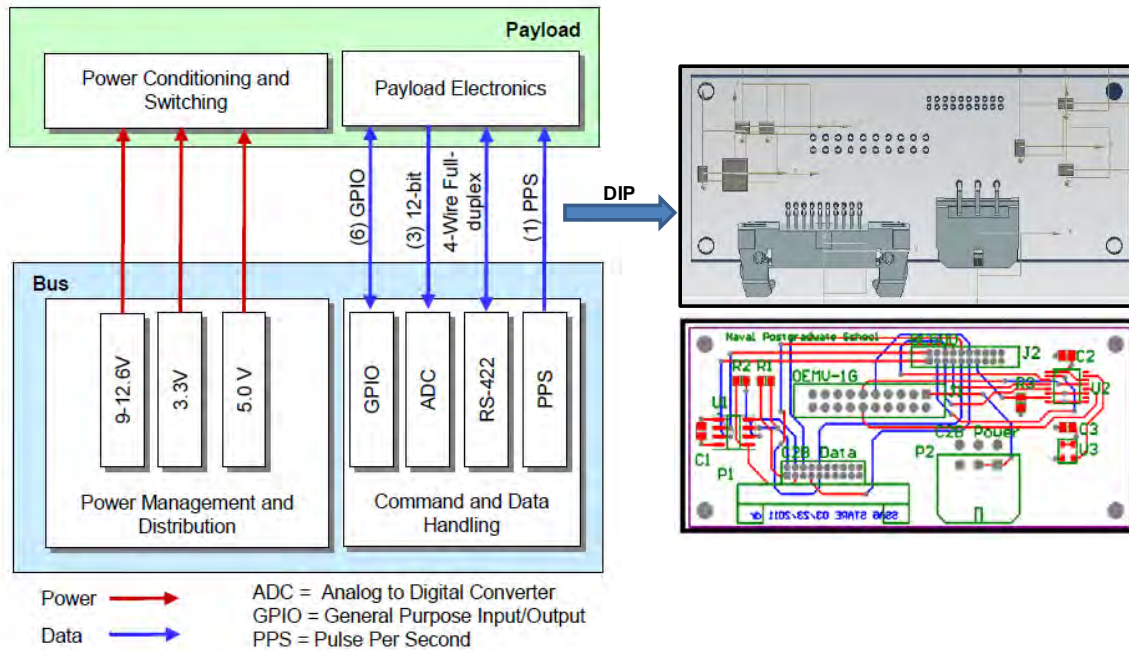

Figure 20. C2B Engineering Model Version 1 (EM-1) with Reaction Wheels Visible

A significant step in preparing for the integration of the payload into the C2B was the development of the Data, Interface and Power (DIP) board, illustrated in Figure 21. The DIP is used in the integration of the optical payload to the bus, providing power and commands to the payload and data back to the bus. It was designed, fabricated and tested at NPS. It was designed specifically for STARE; however, the concept is going to be reproduced to accommodate other C2Bs and their respective payloads. A standard interface board is also being designed, fabricated and tested for use on other projects. Once validated, the interface board will be sent to other higher education learning institutions and laboratories for use on their respective projects. Similar to the function of the C2B, the interface board will serve as a customizable interface board for integration and testing of generic payloads to the C2B.



UNCLASSIFIED

Figure 21. Data Interface and Power Board to Integrate STARE Payload to C2B (After NanoSat Engineering, 2011, Pg.40 and Riot et al., 2011 Slide 73)

Engineering model version 1 along with the umbilical box and the connecting cable is depicted in Figure 22.

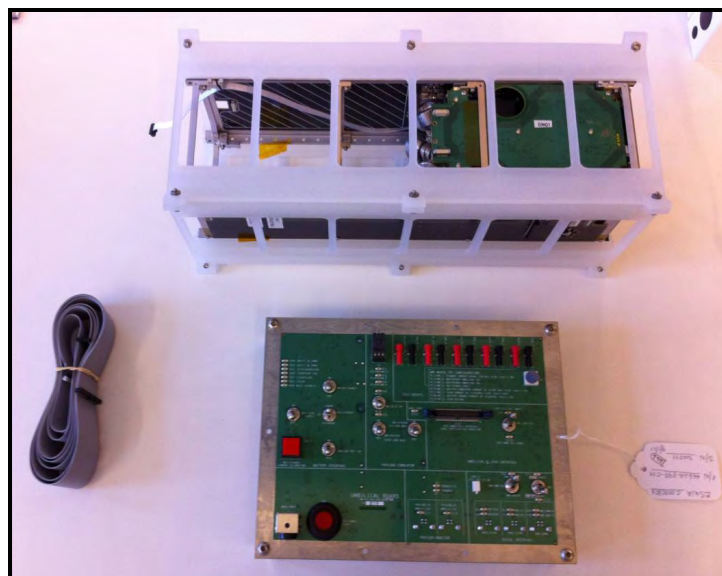

Figure 22. C2B Engineering Model Umbilical Box and Cable

Integration of the flight unit at Boeing with NPS participation was completed in late November 2011. The flight unit has the flight software NanoSat GSS version 7.1.0 and the upgraded Nano View. Unlike the previous versions of the NanoSat GSS, the flight version is easier to program and it is more versatile. The flight unit is pictured in Figure 23.

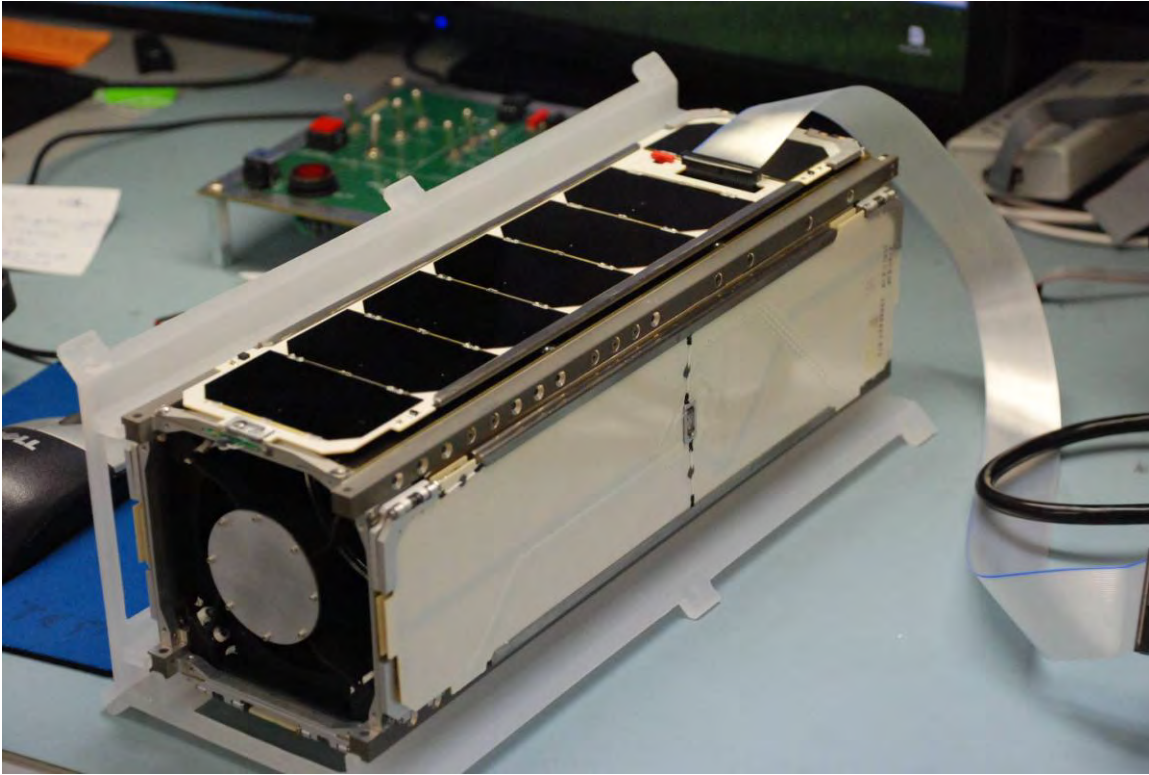

Figure 23. C2B Flight Unit in Transport Structure

THIS PAGE INTENTIONALLY LEFT BLANK

### **III. PAYLOAD MISSIONS AND GOALS**

#### **A. TECHNICAL GOALS (LLNL INPUT)**

The initial goal of the project is to create two pathfinder CubeSats to test the feasibility of using a 3U CubeSat with an optical payload to refine conjunction analysis in support of SSA. In the event the CubeSats are successful in their mission, more work will be done in the area to further the use of CubeSats for space based space surveillance. This system is not intended to be heavily requirement driven, but to demonstrate the usefulness of space based sensing for refining orbital parameters. LLNL's involvement in SSA since 2008 began with the implementation of a large-scale simulation call the Testbed Environment for Space Situational Awareness (TESSA). TESSA is a collaboration between LLNL, Los Alamos National Laboratory, Sandia National Laboratories and the Air Force Research Laboratory (AFRL) with the aim of improving performance analysis of the SSN. STARE Mission Hardware in the Loop Environment (SMILE) software will be used for operations on the ground with STARE. The payload data from STARE will feed into SMILE for improved ephemeris data for conjunction analysis.

#### **B. MISSION GOALS**

The mission goal is to have the CubeSats send images to the ground station for analysis after launch and initialization. Once the data is received at the ground station, the payload data will be forwarded to LLNL. The data will then be analyzed and orbital parameters computed and refined by the lab's supercomputers. For mission success of the two pathfinder satellites, it is important for them to collect some data to demonstrate refined orbital parameters on an orbiting object based on the orbital parameters. The technical goals of the program and the usefulness parameters of the satellite are summarized in Appendix A, STARE Science goals.

For the optical imager on the payload to take an image, the CubeSat's view must not be obstructed by the earth or moon. It should be in the earth's shadow or umbra, while the target must be in the full sunlight. The sun constraint shown in Figure 24 was one of several constraints modeled in the STK simulation of the STARE orbit.

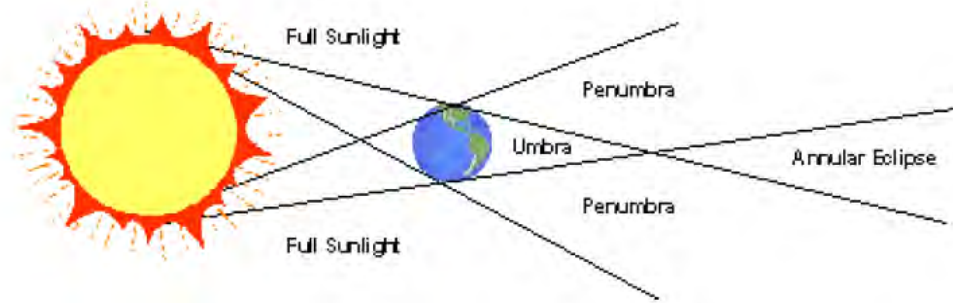

Figure 24. Depiction of umbra and full sunlight (From Flanagan 2010, Pg 13)



## IV. SSA CUBESAT CONCEPT OF OPERATIONS (CONOPS)

### A. MODE OF OPERATION

The C2B can operate in three types of modes, namely normal, sun-safe and survival mode depending on the situation. Figure 25 illustrates the modes of operation and the faults that could trigger the spacecraft to operate in the sun-safe or survival modes. Electrical power system (EPS), attitude determination control and navigation system (ADCNS) and command, data and handling (CD&H) sun-safe (SS) faults are examples of faults that can trigger the spacecraft to go into the sun safe mode. Similarly, EPS, ADCNS and CD&H survival faults can trigger the spacecraft to go into the survival mode. These faults deviate from normal operations and are designed to preserve the payload and bus in the event of abnormal operations.

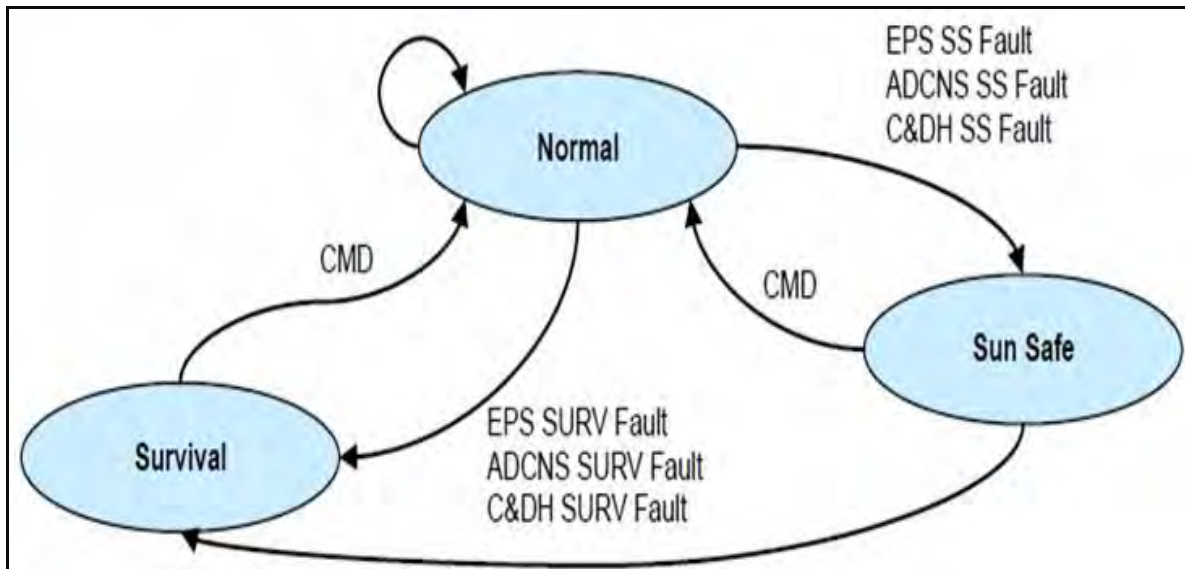

Figure 25. C2B Modes of Operation (After NanoSat Engineering, 2011, p. 52)

## 1. Normal Mode

The normal mode is the standard operating condition of the spacecraft and the desired mode of operation. A summary of normal operation is listed in Table 6.

MODE:		NORMAL
Characteristics:		Normal mode of vehicle A processor reset will <b>NOT</b> auto trigger a transition to one of the contingency modes Possesses contingency operations for extended loss of COMMS
System Status	PAYLOAD:	Nominal (ON)
	C&DH:	Nominal
	ADCNS:	All modes accessible
	EPS:	All power service powered on
	COMM:	On-command receivable
Triggers/Faults:		
Mitigations:		Radiation mitigation implemented
Exits:		Exit to Sun-Safe mode upon SS mode triggers (autonomously) Exit to Sun-Safe mode through ground station commands Exit to Survival mode upon SURV mode triggers (autonomously) Exit to Survival mode through ground station commands

Table 6. C2B Normal Mode of Operation (Data derived from NanoSat Engineering 2011)

## 2. Sun-Safe and Survival Modes

When the satellite operates in either the sun-safe or the survival mode, it indicates a fault response has been triggered and the satellite is no longer operating in the normal mode. The sun-safe mode is a level less serious than the survival mode. Table 7 gives an overview of the SS and survival modes of operations.

MODES:		SUN-SAFE (SS)	SURVIVAL (SURV)
Characteristics:		First level of bus contingency operations Vehicle is pointed in a solar inertial orientation to provide long term autonomous operations Payload will be turned off and should remain off Only sequences of highest priority (A) are executed SC has the ability to connect solar array power directly to SC Possesses contingency operations for extended loss of COMMS	Only the CRITICAL bus functionality maintained to provide power and communicate with SC Attitude of the SC is <b>NOT</b> actively controlled Only sequences of highest priority (A) are executed Possesses contingency operations for extended loss of COMMS
System Status	PAYLOAD:	OFF (PLD Power Services DISABLED)	OFF (PLD Power Services DISABLED)
	C&DH:	Nominal	Nominal
	ADCNS:	2-Axis Sun Track Attitude sensors include Sun and Mag ( NOT IRB) Attitude Actuators include wheels and torque coils	Free Drift
	EPS:	Reduced power mode (IRB OFF)	ONLY power critical services (C&DH, EPS, COMM)
	COMM:	On-command receivable	On-command receivable
Triggers/Faults: * See Note 1		EPS SS Fault Battery SOC (<10 V) ADCNS SS Fault C&DH SS Fault	EPS SURV Fault Battery SOC (<9 V) ADCNS SURV Fault Failure to Control Attitude - TIER 2 Fault High Bus Angular Velocity - TIER 2 Fault (10 deg/sec) C&DH SURV Fault
Mitigations:		Radiation mitigation implemented	Radiation mitigation implemented
Exits:		Exit to Survival mode upon SURV mode triggers (autonomously) Exit to Survival mode through ground station commands Exit to Normal ONLY through ground commands	Exit to Normal ONLY through ground commands

NOTE 1	Four conditions <b>MUST</b> be met in order to trigger a fault response:	
	Fault test must be enabled	Ready to receive fault
	Fault test must be failing	Fault received
	Fault must be mapped to pre-planned response (PPR)	PPR has been determined
	Fault response must be enabled	Ready to carry out PPR
Faults can only be cleared through ground command after root cause of fault has been determined and corrected; <b>EXCEPTION</b> - auto momentum desaturation, which is cleared when complete		

Table 7. Sun-Safe and Survival Modes of Operation (Data derived from NanoSat Engineering 2011)

## B. POINTING CAPABILITIES

To perform the space based space surveillance mission, STARE will use the same sidereal track mode of operation used on SBV and SBSS. The CubeSat will point at the stars using them as reference points. The stars appear stationary in the frame while the satellites or orbital debris are streaks as shown in Figure 26. To get useful data, it is essential to maintain 1-degree sensor pointing accuracy or better. However, the goal is to have 0.31 degree pointing accuracy. Along with the pointing accuracy, imager pointing stability is critical. The attitude control subsystem is responsible for ensuring a reasonable level of pointing accuracy. The pointing or orientation time should be less than 24 hours, assuming the ground is sending the next pointing information after exposure, with self-position accuracy, determined by the onboard GPS, having a value less than 50 meters. The maximum slew rate of the satellite is 3 degrees per second, which occurs in less than a minute, and the ideal slew rate is 0.25 degrees per second in a time span less than ten minutes. The ideal STARE pointing stability is 0.052 degrees per second smear rate and 0.02 degrees per second jitter rate (From Olivier, Perticia, Bauman, Simms, & De Vries, CubeSat sensor system engineering overview version 1.1.10, 2011, p. 10, 14).



Figure 26. Sidereal Track (From HQ Air Force Space Command/A3CD, 2007, p. 124)

### C. COMMAND AND DATA HANDLING

The command and data handling (C&DH) module of the spacecraft is supported by the C2B, to include both uplink and downlink paths. It includes hardware and software used in spacecraft control and the interface between the bus and payload. The characteristics of the C&DH module are outlined in Table 8.

Element	Performance	Notes
 C&DH module	Power 0.65 W (average)	0.33W (min), 0.97 W (max), assume 50% duty cycle
Data Storage	Effective Shared Capacity 2GB	Data is written redundantly to two FLASH memory devices (2x2GB) and is shared between Bus and Payload Data
	CMD Schedule Resolution 1 second Max Num of Sequences 300 Max Num of Commands 500 Max Num of Parameters 1500 Total Parameter size 36000 Bytes	Several commands can be executed at the same time based on priority. Commands are serviced as quickly as the spacecraft processor can process them. Sequences, Commands, and Parameters use shared memory and are limited by any of the maximum parameters listed.
Telemetry Bus	Bus SOH rate 90 kB/min	Maximum telemetry rate based on typical 1 minute snapshots with additional attitude control data saved 1 Hz

Table 8. Characteristics of the C&DH Module (From NanoSat Engineering, 2011, p. 13)

The operator schedules an observation command to the satellite. When commanded, the satellite will point to the area of interest to collect data. The area is defined by a pointing vector and time of conjunction. The time is estimated to be accurate within five seconds (From Riot, Olivier, Perticia, Bauman, Simms, & De Vries, CubeSat sensor system engineering overview version 1.1.10, 2011a, p. 14). The satellite collects raw image data, processes it by extracting pertinent information, stores the processed data then discards the raw image. The output is the processed data, and a typical observation is

defined by a UTC time, pre-processed measurement and corresponding GPS information. This processed data is then stored and transmitted when requested by the ground station.

#### **D. DATA FORMAT**

The C2B telemetry data will be processed by the ground station. Both uplink and downlink byte flow utilize the first in first out (FIFO) sequence and each byte follows the Little Endian architecture. C2B uses two external interfaces for full duplex communication: 9.6 kbps uplink at 450 MHz and 57.6 kbps downlink at 915 MHz. The message data will be encoded using a 256-bit Advanced Encryption Standard (AES) algorithm in both uplink and downlink streams. To use the AES-256, the data must be padded to ensure it is an integral number of 16 bytes in length. For the data, there is an optional Forward Error Correction (FEC), which has significant overhead and is dependent on the amount of raw data (From Naval Research Lab ICD, 2011. p. 12).

The message frame format is the overall structure of the expected data format and a description of the message's data header, parameter data and cyclic redundancy check (CRC). Parameter data is the data that is either being sent to the spacecraft from the ground station or vice versa. Each segment of the data format has associated software overhead. For example, the message identification has one byte and the CRC International Telegraph and Telephone Consultative Committee (CCITT) for error detection utilizes two bytes.

#### **E. STORAGE AND DOWNLINK**

The spacecraft stores all data on two 2GB commercial-off-the-shelf (COTS) flash memory drives. The overall effective shared capacity is 2GB instead of 4GB. The 2GB flash memory devices can be upgraded to 4GB if extra storage is needed. For STARE, 2GB of storage is sufficient for the raw image files and processed data to be collected. Both the bus and the payload share the

storage for vehicle State-of-Health (SOH) and payload data. If the SD card were to fill up, no additional information can be saved (From NanoSat Engineering, 2011, p. 43).

## F. GROUND STATION ARCHITECTURE AND REQUIREMENTS

The mobile CubeSat command and control (MC3) common ground architecture (CGA) has two hubs: one at the Space Operations Center (SOC) Blossom Point, MD and the other at the Naval Postgraduate School, Monterey, CA. NPS will be the hub for all university networks of MC3s and the university CubeSats will be operated from this location. Figure 27 provides an overview of the ground station architecture and how NPS will fit operationally into the CGA. It also gives an overview of NPS's role as the center for university networks, while SOC- Blossom Point will be the hub for all other users.

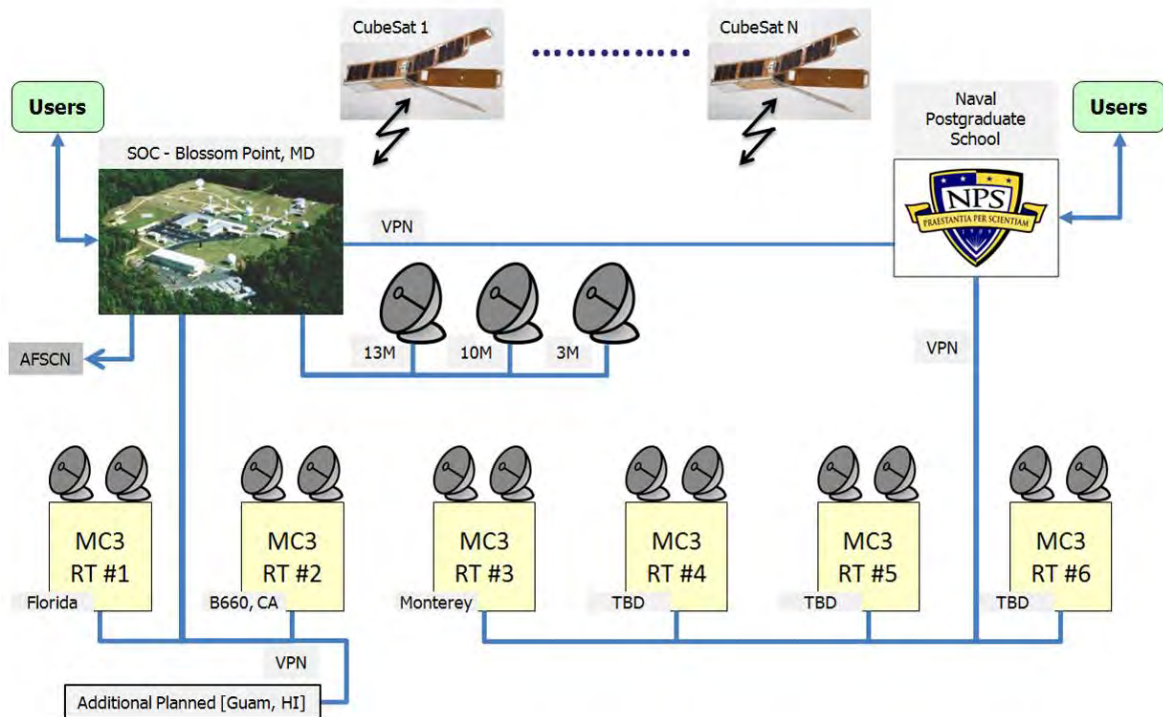

Figure 27. Top-Level Ground Station Operations Architecture (Arnold, Johnson & Davis, 2011, Slide 4)

The plan is to have nine MC3 ground station locations worldwide. The locations consist of universities and government sites. For the purpose of this thesis, emphasis will be placed on the NPS MC3 site. The NPS MC3 site will be the first of the nine operational sites listed in Table 9.

<b>Institution</b>	<b>Location</b>
University of Alaska	Fairbanks, Alaska
Utah State University	Logan, Utah
Air Force Institute of Technology	Dayton, Ohio
Naval Postgraduate School	Monterey, California
Air Force Research Laboratory	Albuquerque, New Mexico
Texas A&M University	College Station, Texas
Space/Ground System Solution	Melbourne, Florida
University of Hawaii	Pearl City, Hawaii
Naval Base Guam	Agat, Guam

Table 9. MC3 Ground Station Locations (Data derived from Griffith, 2011, p. 36)

## **G. TRACKING TELEMETRY AND COMMAND (TT&C) LINK**

The data transport protocol for the C2B has two external interfaces for communication and they are satisfied by 57.6 kbps downlink and 9.6 kbps uplink streams. MC3 ground station operators will have the ability to pass commands to the satellite without interfering with the data downlink from the satellite at all times the spacecraft is in view of a ground station. The full duplex system has a radio that uses the standard AX.25 Unnumbered Information (UI) frame defined in the AX.25 Amateur Packet-Radio Link-Layer Protocol with UHF bands that operate with an uplink at 450 MHz and downlink at 915 MHz. MC3 ground station operators are required to have an Amateur Radio license because they will be operating in the Amateur Radio frequency (RF) band (From Naval Research Lab ICD V2.0, 2011, p. 14).



## **H. DATA TRANSFER REQUIREMENTS**

Data originating from the payload is transferred to the bus and then to the ground station. This payload data will be intermediately stored on the SD file system. Spacecraft telemetry is also stored on the SD card. The contents of the SD files can be downloaded to the ground station via RF downlink.

## **I. POWER MANAGEMENT**

The C2B provides electrical power for the entire spacecraft. The electrical power subsystem for the CubeSat is comprised of the power management and distribution (PMAD) board, Li-ion battery packs and Spectrolab's Ultra-Triple Junction (UTJ) solar cells. The PMAD is capable of handling a payload peak power of 70 watts for 20 minutes. In the free-fall mode, the bus stand-by power requirement is 0.3 watts, with nominal power of 5 watts and max power of 16 watts. So based on the PMAD max power handling capability, it will be able to manage the STARE payload power of approximately 3 watts (From NanoSat Engineering 2011, p. 23).

The battery pack consists of two energy storage modules that provide power to the spacecraft loads during periods of eclipse and peak load conditions during sunlit periods. The battery pack is capable of providing voltages between 9 and 12.6. In the event the spacecraft has to go into "safe mode," due to undercharged batteries, the C2B has the ability to connect solar array power directly to the spacecraft to support limited vehicle operations (From NanoSat Engineering 2011, p. 22–23).

## **J. THERMAL EFFECTS ON SATELLITE**

The thermal effects of space on the C2B have not yet been observed operationally. However, there have been data collected on thermal effects on other CubeSats and during the environmental testing of the C2B. From the extensive thermal modeling on the payload by TAMU and the thermal modeling

of the satellite and testing conducted at NPS, there are no thermal constraints on the satellite to impact its mission (Lozada, 2011).

## V. DATA COLLECTION AND HANDLING ANALYSIS

All tests were conducted in the ground configuration using the Boeing Company's computer programs NanoSat GSS and Nano View. This software runs on a windows PC which interfaces with the Umbilical box (U-Box) using the USB. The NanoSat GSS program delivers commands to and receives the response from the spacecraft while Nano View processes the telemetry response. The ability for the spacecraft to conduct data collection and handling in the ground configuration was tested and results documented. Using NanoSat GSS and Nano View, commands were sent to the C2B and the payload simulator. Receipt of the command and response from the payload were verified. While retrieving data from the on-board storage proved problematic using the standard command to get archived information, a work around was developed to download data from the SD card. The integrated payload testing configuration is depicted in Figure 28. The actual Engineering Model version 1, the umbilical box and the cable used to connect them together are shown in Figure 29.



Figure 28. Electrical Ground Support Equipment (From Riot et al., 2011b, p. 6)

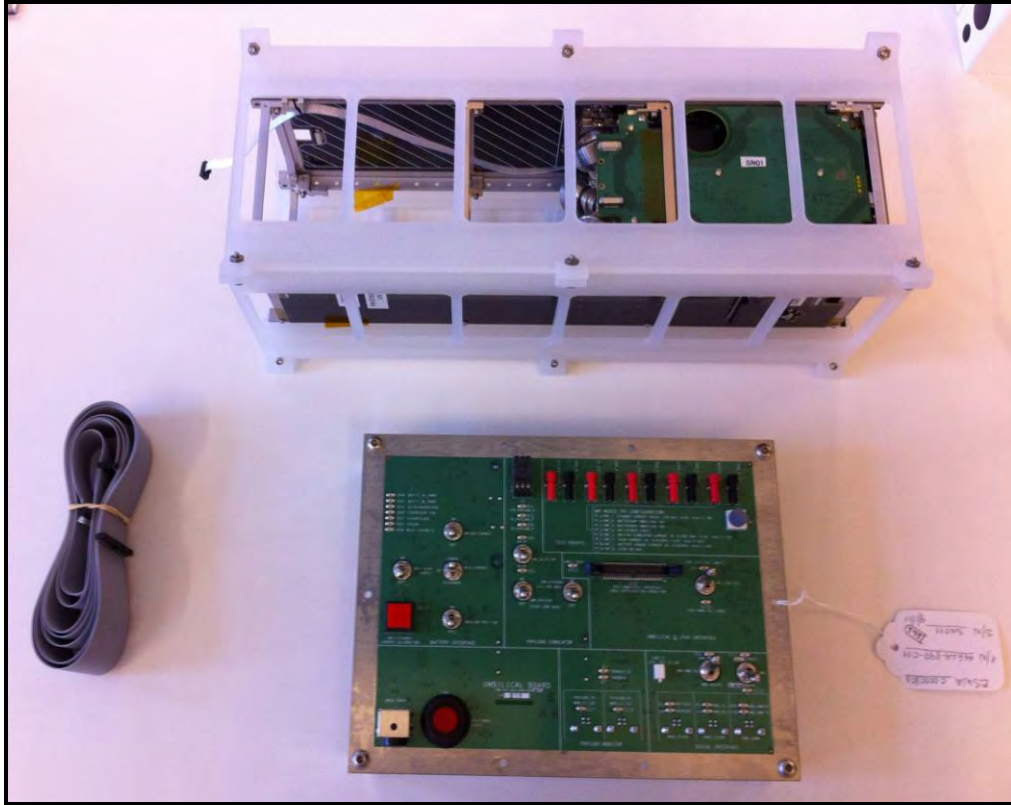

Figure 29. C2B Engineering Model (EM-1), umbilical box and cable

#### A. NPS MC3 GROUND STATION

Analysis was performed using the Systems Tool Kit (STK) to model the STARE orbit and obtain ground-link access information. The number and duration of ground accesses by the spacecraft were determined for a yearlong period. Table 10 depicts the number of accesses and the total duration the spacecraft is in view of each of the ground stations in minutes. Each ground station has a 10-degree elevation constraint, i.e., the spacecraft must be at least 10 degrees above the horizon.

Year Long 20 Jul 2011- 20 Jul 2012		
Orbit - 65° @ 463 x 833.4 km		
Location w/ 10° elevation constraint	# Accesses	Total Time (mins)
Fairbanks, AK	2368	22280.1
Logan, UT	1888	15382.5
Dayton, OH	1766	14411.4
<b>Monterey, CA</b>	<b>1617</b>	<b>13163.2</b>
Albuquerque, NM	1564	12675.1
College Station, TX	1421	11474.6
Melbourne, FL	1366	10945.2
Pearl City, HI	1243	9789.9
Agat, Guam	1149	8847.5

Table 10. STARE Year Long Access to MC3 Ground Stations

From the yearlong access data, a daily average was calculated and the information is in Table 11.

Location w/ 10° elevation constraint	Latitude of Ground Station (° North)	Average Number of Access/day	Average number of minutes/access	Total average access times per day (mins)
Fairbanks, AK	64.8	6.49	9.41	61.0
Logan, UT	41.7	5.17	8.15	42.1
Dayton, OH	39.6	4.84	8.16	39.5
<b>Monterey, CA</b>	<b>36.6</b>	<b>4.43</b>	<b>8.14</b>	<b>36.1</b>
Albuquerque, NM	35.1	4.28	8.10	34.7
College Station, TX	30.6	3.89	8.07	31.4
Melbourne, FL	28.1	3.74	8.01	30.0
Pearl City, HI	21.4	3.41	7.88	26.8
Agat, Guam	13.3	3.15	7.70	24.2

Table 11. Daily Average Access Data for STARE to Ground Stations

Using the average daily access times over Monterey, uplink and downlink data rates, total quantity of observation data and raw image data, analysis of the spacecraft's ability to communicate with the ground station was performed. Taking into account the 2GB storage available on the SD card, storage was not the limiting factor in the data collection, handling and transfer process. From extensive testing already performed at NPS, the limiting factor was data throttling between the payload and C2B. Even though LLNL payload performs data compression of both raw image files and processed data, generation of data

between passes over a ground station leaves the possibility for accumulation of large data files. The ability to transfer the large amounts of data from the payload to the bus proves problematic at this point. The limitation in data throttling is inherent to the software protocol of the C2B flight unit, because the hardware flow control with the clear to send/ready to send (CTS/RTS) line has not been implemented.

## **B. SENDING COMMANDS TO SATELLITE**

Several commands are required for the payload to take images, process the data, keep the processed information and discard the raw image file. After extensive software testing of the EM, a series of commands were uploaded to direct the payload to take pictures.

When commanded, the satellite orients itself to point in the requested position and turns on the payload. The payload is then instructed to acquire data in the form of ten images of one-second exposure around the predicted time and location of conjunction. The images are time-stamped with one millisecond accuracy or better (From Riot, Olivier, Perticia, Bauman, Simms, & De Vries, *CubeSat sensor system engineering overview V1.1.10*, 2011a, p. 14). The commands can be uploaded during a ground station pass and stored for execution at a designated time in the orbit as determined by LLNL analysis.

## **C. OBSERVATION STRATEGY OF SATELLITE**

The NPS site allows for about 30 minutes of data downlink per day at 57.6 kbps. This results in a total downlink capacity of approximately 10 MB of data per day. STARE images are 1280 x 1024 pixels in size, or 1,310,720 pixels total. Most of the data in the image are not useful because they comprise detector noise and sky background. That is where the raw image file and the processed data come into play. The processed data files contain pertinent information extracted from the raw image file and the information will be fed into TESSA to refine ephemeris data (Simms et al., 2011).

The precise position and time of the spacecraft at time of observation is contained in the GPS logs that are recorded simultaneously with the image capture. The size of each GPS log is approximately 300 bytes. Stellar positions in detector coordinates give a very accurate pointing of the target once matched up to the cataloged positions. The location and intensity of up to 100 of the brightest stars in the image are recorded. Finally, the track endpoint positions in detector coordinates tell where the target was at the start and end of the observation (Simms et al., 2011). Figure 30 is a simulated image of what Iridium 16 would look like as a product of STARE during a conjunction. The movement of the Iridium communications satellite through the frame will appear as a line while the stationary stars look like dots. If the image was not processed, the image would be filled with noise and sky background. The raw image from the payload has an average size of 600 to 700 kB after it has been compressed. The processed data file size is much smaller at approximately 1,088 bytes. A total standard observation of 10 images of one-second integration and recurring GPS fixes every second would result in a packet size of roughly 17,987 bytes. The total packet size is comprised of:

- 10 x 1,088 bytes for observation data
- 11 x 645 bytes for GPS streaming data
- 12 bytes for packet header (From Riot et al., CubeSat sensor system engineering overview V1.1.10, 2011a, p. 47)

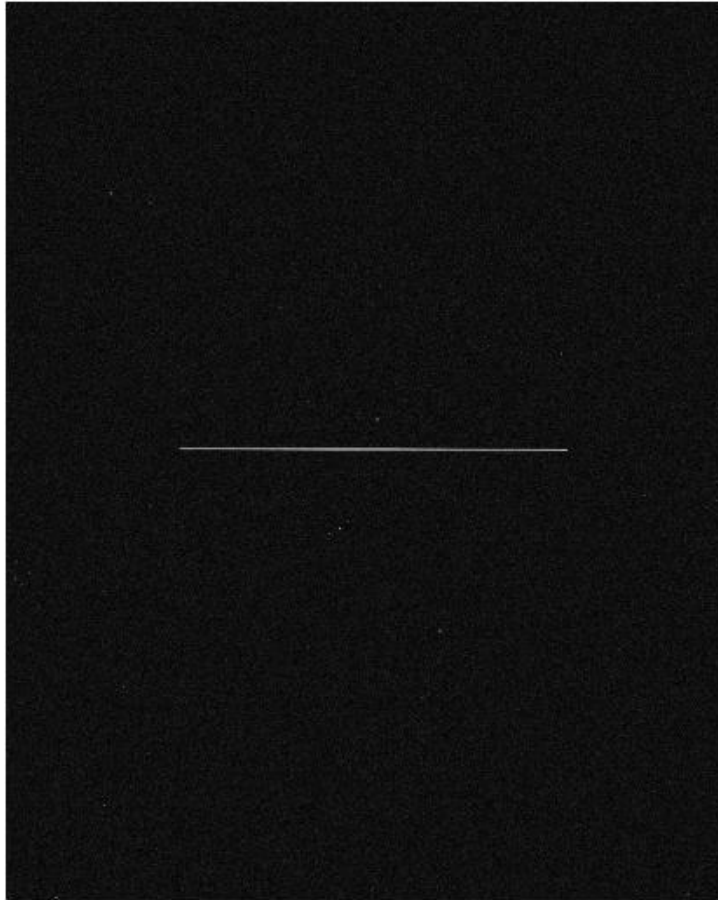

Figure 30. Simulated image for an Iridium 16 conjunction (From Riot, Olivier, Perticia, Bauman, Simms, & De Vries, 2010 p. 59)

#### **D. RECEIVING TELEMETRY DATA FROM SATELLITE**

Data from the satellite are organized and stored by telemetry groups. From Boeing's C2B command telemetry database, there are 16 telemetry groups. The data stored by telemetry groups are logical collections of individual telemetry items. The three bus telemetry groups are Electrical Power System (EPS), Command and Data Handling (C&DH) and Guidance Navigation and Control (GN&C). There are also three payload data groups, Group A, payload I/O group, Group B, payload event group and Group C, the payload serial group, summarized in Table 12.



Payload Data Group	Description
A) Payload I/O group (PL_TLM_A_t)	Records the states (GPIO) and counts (ADC) from digital and analog inputs
B) Payload Event group (PL_TLM_B_t)	Interrupt driven GPIO that records rising edge transition of Payload DIO pins
C) Payload Serial group (PL_TLM_C_t)	Raw Serial data received over the serial link

Table 12. Payload Data Groups (After NanoSat Engineering 2011, p. 43)

Analysis of telemetry data from C2B and STARE serial data gives insight into the amount of data that will potentially be down linked from the satellite. Sixteen groups of telemetry data will be examined with group zero being the health housekeeping telemetry data, group one pertaining to the EPIC power management and distribution and group 14, the payload serial data. Other groups include guidance, navigation and control telemetry data. Using a spreadsheet to compute the amount of data in bytes to store per day, the total bytes to store per day can be estimated. For example, given each group has a storage rate of 60 seconds, the records stored per day can be calculated and subsequently the bytes stored per day. From working with the engineering model software, the 60-second storage rate is not ideal for all the different telemetry groups because some of the telemetry groups like guidance, navigation and control will need recording at shorter intervals to get accurate data from the spacecraft. Along the same concept, the health telemetry might require longer storage rate intervals. Table 13 gives a brief overview of how many bytes will be stored per day based on the STARE payload taking 10 observations and 1 raw image data. Raw image data will not be needed for every collection once the satellite is operational. The processed data is sufficient to get refined ephemeris for possible conjunctions. From Table 13, the amount of data stored per day is 2.20 MB.

Group #	Group Name	Total bytes	Storage rate [sec]	Records stored per day	bytes to store/day
0	HEALTH_TLM_t	244	60	1440	351360
1	EPIC_PMad_SP_TLM_t	172	60	1440	247680
2	GNC_TLM_f01_t	40	60	1440	57600
3	GNC_TLM_f02_t	67	60	1440	96480
4	GNC_TLM_f03_t	36	60	1440	51840
5	GNC_TLM_f04_t	48	60	1440	69120
6	GNC_TLM_f05_t	61	60	1440	87840
7	GNC_TLM_f06_t	58	60	1440	83520
8	GNC_TLM_f07_t	40	60	1440	57600
9	GNC_TLM_f08_t	74	60	1440	106560
10	GNC_TLM_f09_t	63	60	1440	90720
11	GNC_TLM_f10_t	48	60	1440	69120
12	PL_TLM_A_t	15	60	1440	21600
13	PL_TLM_B_t	9	60	1440	12960
<b>14</b>	<b>PL_TLM_C_t</b>	STARE Serial Data			<b>670,880</b>
15	SV_SUM_TLM_t	66	60	1440	95040
16	Event_Logger_TLM_t	24	60	1440	34560
Total download per day		1065		23040	<b>2204480</b>
Total Bytes to store per day			2.20	MB	

Table 13. TLM data with 10 Observations + 1 Raw Image File Scenario (Data from Boeings C2B Command Telemetry Database)

When no raw image files are downloaded, the STARE serial data drops from approximately 671 kB to 10.9 kB as shown in Table 14. The total bytes to store per day are reduced by over 600 percent.

Group #	Group Name	Total bytes	Storage rate [sec]	Records stored per day	bytes to store/day
0	HEALTH_TLM_t	244	60	1440	351360
1	EPIC_PMad_SP_TLM_t	172	60	1440	247680
2	GNC_TLM_f01_t	40	60	1440	57600
3	GNC_TLM_f02_t	67	60	1440	96480
4	GNC_TLM_f03_t	36	60	1440	51840
5	GNC_TLM_f04_t	48	60	1440	69120
6	GNC_TLM_f05_t	61	60	1440	87840
7	GNC_TLM_f06_t	58	60	1440	83520
8	GNC_TLM_f07_t	40	60	1440	57600
9	GNC_TLM_f08_t	74	60	1440	106560
10	GNC_TLM_f09_t	63	60	1440	90720
11	GNC_TLM_f10_t	48	60	1440	69120
12	PL_TLM_A_t	15	60	1440	21600
13	PL_TLM_B_t	9	60	1440	12960
<b>14</b>	<b>PL_TLM_C_t</b>	STARE Serial Data			<b>10,880</b>
15	SV_SUM_TLM_t	66	60	1440	95040
16	Event_Logger_TLM_t	24	60	1440	34560
Total download per day		1065		23040	<b>1544480</b>
Total Bytes to store per day			1.54	MB	

Table 14. TLM with no raw image in the STARE serial data group (Data derived from Boeing's C2B Command Telemetry Database Version 7.1)

In order to find out how much data can be sent from the satellite to the ground station based on the average daily access, the downlink data rate and the software overhead to ensure the transfer of information, a calculator was built to determine an estimated rate. Using the STK analysis of the STARE orbit to compute access times over the NPS ground station with ten degrees elevation constraint and taking into account 80 percent efficiency in the link between the satellite and ground station, the estimated daily pass time is 28.9 minutes. The calculation is summarized in Table 15.

<b>Total Passes</b>	<b>13163</b>	Year duration in minutes
	789,794	Year duration in seconds
<b>Average Passes</b>	2,164	Daily average duration in seconds
	36.1	Daily average duration in minutes
	<b>80%</b>	Efficiency
<b>Daily Pass Time</b>	28.9	min

Table 15. Daily access time from STARE to NPS ground station

The amount of data that can be sent from the spacecraft to ground is based on the downlink data rate and an estimated 15 percent for software overhead, and the 28.9 minutes of daily pass time over Monterey. The calculation is summarized in Table 16.

<b>Data Rates</b>	<b>57.6</b>	kbit/sec
	<b>15%</b>	SW Overhead
	<b>48.96</b>	kbits/sec
	<b>10.35</b>	Mbytes/day

Table 16. STARE data rate calculation

From the initial calculations, the 10.35 MB of data that can be downlinked per day is greater than the actual 2.2 MB of data generated. Therefore, all the payload data and bus telemetry data generated each day can be sent down within the same day. In the event the storage rates were changed from 60 seconds to one second for all the telemetry groups, the total bytes to store per day increases to 92.69 MB, Table 17. This amount of data is extremely high and it would take several days to get the data to the ground station making the information time-late and irrelevant.

Group #	Group Name	Total bytes	Storage rate [sec]	Records stored per day	bytes to store/day
0	HEALTH_TLM_t	244	1	86400	21081600
1	EPIC_PMad_SP_TLM_t	172	1	86400	14860800
2	GNC_TLM_f01_t	40	1	86400	3456000
3	GNC_TLM_f02_t	67	1	86400	5788800
4	GNC_TLM_f03_t	36	1	86400	3110400
5	GNC_TLM_f04_t	48	1	86400	4147200
6	GNC_TLM_f05_t	61	1	86400	5270400
7	GNC_TLM_f06_t	58	1	86400	5011200
8	GNC_TLM_f07_t	40	1	86400	3456000
9	GNC_TLM_f08_t	74	1	86400	6393600
10	GNC_TLM_f09_t	63	1	86400	5443200
11	GNC_TLM_f10_t	48	1	86400	4147200
12	PL_TLM_A_t	15	1	86400	1296000
13	PL_TLM_B_t	9	1	86400	777600
<b>14</b>	<b>PL_TLM_C_t</b>	STARE Serial Data			<b>670,880</b>
15	SV_SUM_TLM_t	66	1	86400	5702400
16	Event_Logger_TLM_t	24	1	86400	2073600
Total download per day		1065		1382400	<b>92686880</b>
Total Bytes to store per day			92.69	MB	

Table 17. TLM data with one second storage rate (Data from Boeing's C2B Command Telemetry Database)

The ideal combination of storage rates would be between one and 60 seconds in a combination to accommodate the different housekeeping telemetry needs of the bus and the STARE mission. The STARE serial data ranges from a few kilobytes to several megabytes depending on whether the satellite has to take images and send the processed data files to the ground station or if the operator requires raw image files. The STARE SSA mission can be fulfilled with the processed data; however, raw image files are required for diagnostic and calibration purposes. A raw image file and processed data file from SBV are shown Figure 31. The technology used by LLNL for the STARE satellite is similar to the SBV spacecraft and as such, STARE produces similar payload data.

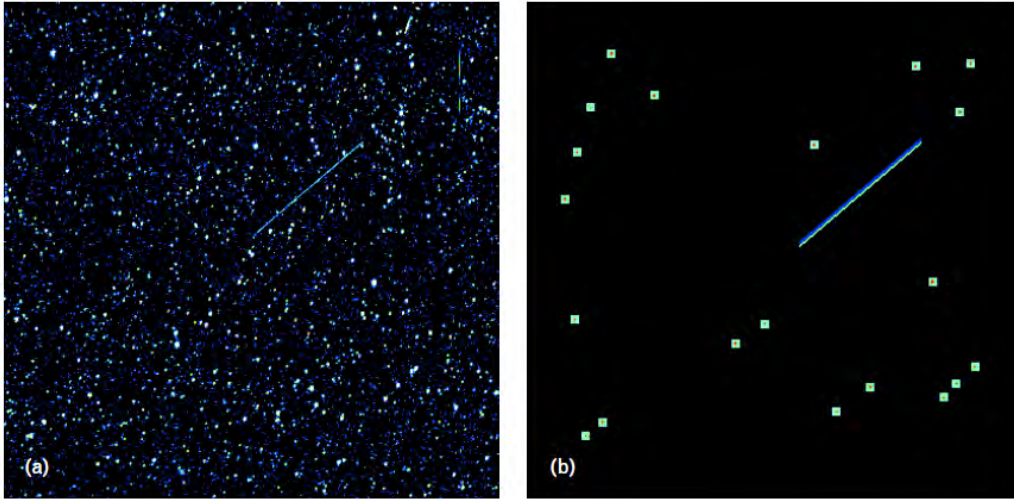

Figure 31. SBV raw full-frame CCD exposure and (b) an associated signal processor image. (From Stokes et al., 1998)

## E. DATA THROTTLING

Due to the fact that hardware flow control with the CTS/RTS line has not been implemented in the C2B payload serial interface, data throttling is necessary. The image files from the payload should be transferred to the C2B at a rate of 115 kbps. However, the data does not transfer at that rate seamlessly. Because the C2B loses payload data, the data is sent in bursts with time in-between data transfer. A series of calculations will be used to illustrate the amount of time it takes to transfer a 1 MB image file to the C2B storage. Ideally, it should only take about a minute to transfer a 1MB data file from the payload to the C2B based on the 115.2 kbps data transfer rate as shown in the calculations in Equations (5-1) and (5-2).

$$\frac{115.2 \text{ kbps}}{8} = 14.4 \text{ kBps} \quad (5-1)$$

$$\frac{1 \text{ MB}}{14.4 \text{ kBps}} = 69.4 \text{ seconds} \quad (5-2)$$

In order to achieve no lost data, the payload sends 20 full-length packets (of 256 bytes) with 100 msec between each packet. After this burst of 20 packets, the payload pauses 5 seconds. This process is then repeated until all the stored payload data is sent to the C2B. The time required to transfer 1 MB of data is calculated in Equations 5–3.3 to 5–9 and the data throttling parameters are given in Table 18.

Data Throttling Parameters	Value	Units
Number of Packets	20	
Number of bytes per packet	256	Bytes
Number of bytes per series	5120	Bytes
Delay 1: delay between packets	0.1	sec
Delay 2: delay between series of packets	5	sec
Data rate	115200	bits/sec
	14400	Bytes/sec

Table 18. Data throttling parameters

$$\text{Time to send 1 data packet} : \frac{256 \text{ Bytes}}{14400 \text{ Bytes/sec}} = 0.018 \text{ sec} \quad (5-3)$$

$$\text{Time to send 1 packet} + \text{Delay 1} : 0.018 + 0.1 = 0.118 \quad (5-4)$$

$$\text{Time to send series of packets} = 20 \times 0.118 = 2.356 \text{ sec} \quad (5-5)$$

$$\text{Time to send series of packets} + \text{Delay 2} = 2.356 + 5 = 7.356 \text{ sec} \quad (5-6)$$

$$\text{Effective data throttling rate} : \frac{5120 \text{ Bytes}}{7.356 \text{ sec}} = 696.1 \frac{\text{Bytes}}{\text{sec}} \quad (5-7)$$

$$\begin{aligned} &\text{Time to transfer 1 MB of data :} \\ &\frac{1000000 \text{ Bytes}}{696.1 \text{ Bytes/sec}} = 1436.6 \text{ sec} \times \frac{1 \text{ min}}{60 \text{ sec}} = 23.9 \text{ min} \approx 24 \text{ min } s \quad (5-8) \end{aligned}$$

From the calculations, it takes approximately 24 minutes to transfer 1 MB of data from the payload to the bus, instead of 69 seconds from Equation (5-2), because of data throttling.

## **F. A DAY IN THE LIFE OF STARE**

Two scenarios were used to illustrate a typical day in the life of the STARE satellite. The first scenario represents the initial spacecraft operations from when it is ejected from the launch vehicle. The second scenario illustrates a typical day in the life of the satellite and what type of interaction the operators would have with the satellite from command upload to payload data download.

### **1. Initial Operations**

Starting from when the STARE satellite is deployed from the CubeSat launcher, NPSCuL, a series of events should occur. The spacecraft will be released from the P-POD and subsequently enter into Pre-Operation mode. The First Time Flag (FTF) stored in the vehicle's non-volatile memory should be cleared upon power-up. After deployment and the expiration of a 30 minutes timer, the vehicle will perform the post P-POD deployment sequence, which includes deployment of the solar panels and antennas. The satellite will maintain the orbit established when it is ejected from the ATLAS V Evolved Expendable Launch Vehicle (EELV) flight L-36. LLNL's analysis shows that sun synchronous inclinations at 700 km are optimal for large number of observation opportunities for STARE (From Riot, Olivier, Perticia, Bauman, Simms, & De Vries, 2011a, p. 52). The two STARE satellites are currently manifested as part of the Operationally Unique Technologies Satellite (OUTSat) program that incorporates NPSCuL and eight CubeSats. The planned OUTSat orbital parameters are 463 km altitude at perigee and 834 km altitude at apogee with a 65-degree inclination. STK analysis for STARE was performed using the planned OUTSat orbital parameters.

Once STARE is released from the P-POD, it takes up to six orbits for the satellite to de-tumble and gain attitude control. Once it gains attitude control, it goes into the sun-soak orientation so the batteries can charge. At this point, the satellite should be ready to receive commands from the MC3 ground station. For the pathfinder satellites, the goal is to have the payload take pictures of a target.



A raw image file of the target is needed for calibration and diagnostics. Once the payload takes the image, the file will be sent to the C2B. When the satellite is in view of a ground station, it will begin downloading the processed data requested by the operator. The payload data downloaded to the ground station will be sent to LLNL so the ephemeris data can be refined.

## **2. Constellation Routine Operation**

If STARE is successful in proving the concept of using CubeSats to conduct space-based space surveillance in support of SSA, a constellation of at least 18 satellites will be launched. Routine operation for the satellites will follow a format similar to the one described below. After satellite checkout, tasking the satellites will be routine and the need to download raw image files will be limited to diagnostics and calibration purposes. Since the constellation will be used to support the SSN, LLNL have access to the orbital debris catalogue. The goal of operations would be to refine ephemeris data to reduce the uncertainty in the current conjunction analysis. Constellation operations are explained below. Operations begin with using existing data available in the JSpOC Satellite Catalogue (SATCAT), which contains a historical record of resident space objects (RSOs) (HQ Air Force Space Command/A3CD, 2007).

- Current orbital debris catalog input to TESSA at LLNL
- TESSA looks for possible conjunction in the next 36 hours. The information will be fed into SMILE to determine the best mission opportunity.
- LLNL provides the possible conjunction to NPS MC3 ground station in the form of
  - Pointing
  - Time of conjunction
- NPS commands STARE from MC3 ground station to take images of the possible conjunction.

At this point, the command is queued until the satellite is in view of the ground station. Once in view of the ground station the commands are uplinked to

the satellite. If the event is scheduled to happen in the future, the command goes into a queue on the C2B where it is stored until it is time to send it to the payload. When the spacecraft begins to execute the commands, a series of events occur.

- Satellite performs slew maneuver from sun-soak orientation
  - The satellite slews at a rate of 0.25 degrees per second while maintaining orientation. If the satellite were to slew at a rate greater than 0.25 degrees per second, but less than the max slew rate of 3 degrees per second, the spacecraft cannot maintain attitude control within the 0.31-degree accuracy; and thus the satellite would need to regain its orientation to get useful GPS data before executing the command.
- The payload takes up to ten observations at one-second exposure times. The standard command is set for ten exposures; however, the user can specify any number of images to be taken from one to ten.
- After the payload takes the pictures of the target, the satellite slews back to the sun-soak orientation.
- The payload begins processing the images to extract pertinent data
  - GPS positions and time of observations
  - Star locations
  - Target track endpoint locations
- The processed data is transferred from the payload to the C2B at a throttled data rate where 1 MB takes ~24 minutes.
- When the satellite is in view of the ground station, payload data stored on the SD card of the C2B is downlinked to the NPS MC3 ground station.
- Payload data is transferred to LLNL for computing using the lab's super computers.
  - The payload data from STARE will feed into SMILE for analysis.
  - The ephemeris data is refined using TESSA.

## F. ANALYSIS CONCLUSION

Preliminary calculations indicate the probability of imaging an unintended target using the optical payload is minimal. The optical payload has a small field of view (FOV) of 2.08 x 1.67 degrees. Since the values are small, they were converted to radians and multiplied to get an overall FOV of 0.00106 radians and this corresponds to angle in Figure 32. The area  $r^2$  is the area the payload can image at a time and the entire sphere has a solid angle of  $4 \pi$  steradians or 12.566 sr. The entire area represents the sky and  $r^2$  the portion the payload can see.

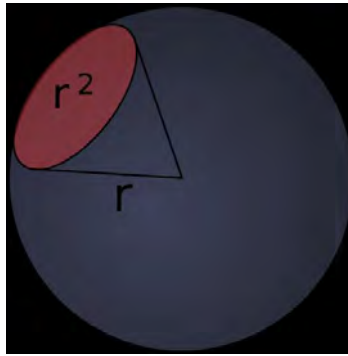

Figure 32. STARE FOV in Steradians

The percentage of the sky covered by the optical payload based on the FOV of is 0.000084% as shown in Table 19. That is the payload can only image approximately 1/10,000<sup>th</sup> of the sky at any given time.

FOV 1	2.08	degrees
	0.0363	radians
FOV 2	1.67	degrees
	0.0291	radians
STARE Field of view (FOV 1 x FOV 2)	0.00106	radians <sup>2</sup>
Sphere in steradians	12.566	steradians
Percentage of sky covered by STARE	8.42024E-05	Percent
	0.000084	%

Table 19. Percentage of sky the payload can image based on FOV

Since the payload can only see  $8.4/100,000^{\text{th}}$  of the sky and there are approximately 22,000 pieces of debris cataloged and tracked, ideally when pointed, the satellite should see about two pieces of debris. This is assuming STARE can only see the objects currently in the catalog, and nothing smaller, and that the objects are uniformly distributed. However, this is not the case. The criteria necessary for STARE to image a target limit the number of orbital debris it can image. For example, a target has to be  $\leq 300$  km in distance and traveling at a relative speed  $\leq 3$  km/s. Therefore, the chances of imaging several targets or an unintended target in a series of 10 observations are low. In conclusion, if the satellites were tasked to image a target, and a processed image was retrieved, it will most likely be of the intended target.

## **VI. CONCLUSION AND FUTURE WORK**

### **A. FUTURE WORK**

At the conclusion of research for this thesis, several areas of work still need exploration to give a better understanding of the spacecraft's capabilities. Some areas that need exploration are listed in this chapter, but the areas for future work are not limited to the suggestions below.

#### **1. STARE Program Manager**

The program would benefit from a dedicated student program manager to handle, document and compile all the schedule, cost and performance related aspects of the program. The program manager position provides a great learning experience for military students at NPS pursuing Master's Degrees in Space Systems Operations. It also provides an insight into the world of space systems acquisition.

#### **2. Further Testing of FV1**

Potential future work on the STARE satellite itself includes developing an in-depth ground station concept of operations. Preliminary work has been done to begin building the ground station. Once the ground station is complete, the actual operation of the ground station to command the spacecraft and receive telemetry data will need to be tested and documented.

Operational test of the satellite while in orbit and documenting its progress is another area for future work. Radiation, thermal and power impacts on the C2B and data handling of the payload need to be explored as well. Since this is the first iteration of experiments using the C2B, more work can be done to fully understand the bus and explore other payload options for the C2B. An important question that can be answered from the point of view of all the spacecraft subsystems is, how will the satellite operate? In-depth analysis of each

subsystem as it pertains to its performance with the STARE payload will aid in advancement in the technology of utilizing CubeSats for SSA.

Extensive work still needs to be done to understand the C2B's software and ensure it is being used to its fullest potential. All the tests in this thesis were conducted in the ground configuration; conducting tests on the satellite when it is operational could lead to insights on improving the STARE technology and expanding the program to include a constellation of satellites. When the pathfinder satellites have been launched and are operational, the telemetry and raw image files from the spacecraft will need review and analysis.

### **3. Integration and Testing**

Although FV1 (flight vehicle one) was integrated at Boeing with NPS, TAMU, and LLNL participation, future STARE payloads will most likely be integrated at NPS. There are potential opportunities for integration and testing of follow-on STARE payloads into the C2B. Other opportunities may arise to integrate and test other satellites with similar missions. With subsequent iterations of STARE CubeSats, there will be advancements in the technology that could potentially pose different set of challenges than those encountered with the integration and testing of the initial satellite. Each set of challenges provide an avenue for Space Systems students and staff alike to learn and develop a knowledge base in the CubeSat field. For example, the full constellation of refinement satellites will have an upgraded low noise, high performance imager the current CubeSat does not have (Simms et al., 2011).

### **B. STARE FUTURE EXPANSION SUGGESTIONS**

Once the STARE technology in the pathfinder satellites becomes operational and the minimum mission requirements are met, justification for more work in this field will be easier to establish. The initial project will comprise of two satellites. Expansion of the program to include a constellation of 18 CubeSats would be the next phase in the STARE project (Simms et al., 2011). To satisfy

the objectives of the program and to fill the gap in the requirement for space-based space surveillance, operational control (OPCON) will need to shift to STRATCOM if the primary mission of the STARE CubeSats is SSA in support of the SSN. In the meantime, during maturation of the technology, the process of integrating the results of the conjunction analysis done with LLNL supercomputers from the payload data into the SSN would need to be streamlined. Timely data transfer between the MC3 CGA network and LLNL for payload data analysis and the transfer of the result to the JSpOC for input into the SSN would need to be solidified to ensure the data is relevant.

Since the decommission of the SBV program and cancelation of the SBSS Block 20 satellites leaves only one SBSS satellite in operation, an important question that needs to be addressed is will a constellation of STARE CubeSats satisfy the space-based space surveillance satellite needs of the SSN?

### **C. SUMMARY**

This thesis provides an overview of the STARE CubeSat's concept of operations. It explores the space surveillance network as it pertains to space situational awareness and the use of STARE to support the SSN in its SSA mission. It chronicles the background, development and integration of the optical payload into Boeing's Colony II Bus and testing of the engineering model, engineering design unit and flight unit. Software testing of the spacecraft was performed in the ground configuration to include sending commands to the spacecraft and receiving telemetry data from the payload. An excel calculator was built to enable quick reference calculations to give a rough estimate on how much data can be sent to the spacecraft and how much data can be received within a given timeframe, taking into consideration onboard storage, uplink and downlink data rates and software overhead to ensure effective links. The camera on-board the spacecraft was tested by commanding it to take pictures in the laboratory. The raw image file gave an idea what potential pictures from the

operational satellite might look like. Even though the concept of using CubeSats for SSA is in its infancy, the technology is very promising.



## APPENDIX A. STARE SCIENCE GOALS

Performance		Stretch Goal	Usefulness level
Orbital accuracy after refinement		$\leq 50$ meters	$< 100$ m
		$\geq 1$ day ahead	$\geq 1$ day ahead
Characteristics of objects	Range	$< 1000$ km	$< 100$ km
	Size	$< 0.1$ m <sup>2</sup>	$< 1$ m <sup>2</sup>
	Tangential velocity	$< 10$ km/s	$< 3$ km/s
	Spectrum	Sun light	Sun light
	Observation rate	$\geq 2$ /half day	$\geq 1$ /day
	Sensor position	$< 10$ m	$< 10$ m
	Sensor pointing accuracy	0.3 degree	1 degree
	Imager resolution	$\leq 4''$ / pixel	$\leq 10''$ / pixel
	Imager field of view	$\sim 3$ degrees	$\sim 3$ degrees
	Imager pointing stability	$\leq 1''$ during exposure	$\leq 2.5''$ during exposure
	Imager Signal to noise ratio on object	16 bit resolution	10 bit resolution
		$\geq 100$ SNR	$\geq 100$ SNR
	Exposure Time	1 sec	1 sec
	Time reference accuracy	$< 1$ ms	$< 1$ ms

Table 20. STARE Science Goals (From Riot, Olivier, Perticia, Bauman, Simms, & De Vries, 2011a, p. 10)

THIS PAGE INTENTIONALLY LEFT BLANK

## LIST OF REFERENCES

- Air University Space Primer. (2003). *Chapter 21 Space surveillance theory and network*. Retrieved from Air University website:  
[http://space.au.af.mil/primer/space\\_surveillance\\_network.pdf](http://space.au.af.mil/primer/space_surveillance_network.pdf)
- Arnold, S., Johnson, M., & Davis, M. (2011). *CubeSat technologies: MC3 status update PowerPoint*. Naval Research Laboratories.
- Ball, D. (2011, March). *Space Based Space Surveillance System backgrounder*. Retrieved from Boeing website: [http://www.boeing.com/defense-space/space/satellite/bkgd\\_sbss\\_0311.pdf](http://www.boeing.com/defense-space/space/satellite/bkgd_sbss_0311.pdf)
- Boucher, M. (2011, March 29). MDA to provide operations and maintenance support for DND sapphire satellite system. *SpaceREF Canada*. Retrieved from <http://spaceref.ca/commercial-space/mda/mda-to-provide-operations-and-maintenance-support-for-dnd-sapphire-satellite-system.html>
- Butler, A. (2008, June 10). Space-based visible sensor ceases ops. *Aviation Week*. Retrieved from [http://www.aviationweek.com/aw/generic/story\\_generic.jsp?channel=space&id=news/Spacey061008.xml&headline=Space-Based%20Visible%20Sensor%20Ceases%20Ops](http://www.aviationweek.com/aw/generic/story_generic.jsp?channel=space&id=news/Spacey061008.xml&headline=Space-Based%20Visible%20Sensor%20Ceases%20Ops)
- Flanagan, J. A. (2010). *Enhancing situational awareness using a 3U CubeSat with optical imager*. (Master's thesis). Naval Postgraduate School, Monterey, CA.
- Griffith, R. C. (2011). *Mobile CubeSat command and control (MC3)*. Master's thesis, Naval Postgraduate School, Monterey, CA.
- HQ Air Force Space Command/A3CD. (2007). *Space surveillance network (SSN) site information handbook*.
- Iannotta, B., & Malik, T. (2009, February 11). U.S. satellite destroyed in space. Retrieved from <http://www.space.com/5542-satellite-destroyed-space-collision.html>
- Jenkins, R. D. (2010). *NPS-SCAT: Systems engineering and payload subsystem design, integration and testing of NPS' first CubeSat*. Master's thesis, Naval Postgraduate School, Monterey, CA.

- Kan, S. (2007, April 23). *China's anti-satellite weapon test*. (Congressional Report No. RS22652). Washington, DC: Library of Congress Congressional Research Service. Retrieved on May 13, 2011 from <http://www.fas.org/sgp/crs/row/RS22652.pdf>
- Larson, W. J. & Wertz, J. R., *Space Mission Analysis and Design*, 3rd ed. El Segundo: Microcosm Press, 2005.
- Liou, J. C., & Shoots, D. (2009, July). United Nations' COPUOS receives update on Iridium-Cosmos collision. *Orbital Debris Quarterly News*, 13(3), 2. Retrieved from <http://orbitaldebris.jsc.nasa.gov/newsletter/pdfs/ODQNV13i3.pdf>
- Liou, J. C., & Shoots, D. (2010, October). Chinese debris reaches new milestone. *Orbital Debris Quarterly News*, 14(4), 3. Retrieved from <http://www.orbitaldebris.jsc.nasa.gov/newsletter/pdfs/ODQNV14i4.pdf>
- Lozada, V. C. (2011). *Space-based telescope for the actionable refinement of ephemeris systems and test engineering*. Master's thesis, Naval Postgraduate School, Monterey, CA.
- Keeping the space environment safe for civil and commercial users: Hearing before the subcommittee on space and aeronautics committee on science and technology, House of Representatives, 111th Cong., 1<sup>st</sup> Sess.* (2009) (testimony of Lieutenant General Larry James). Retrieved from <http://www.gpo.gov/fdsys/pkg/CHRG-111hhr48737/pdf/CHRG-111hhr48737.pdf>
- Kelso, T. S. (2009, July 15). Iridium 33/Cosmos 2251 collision. Retrieved from <http://celestrak.com/events/collision.asp>
- Kelso, T. S. (2011, May 21). Chinese ASAT test. Retrieved from <http://celestrak.com/events/asat.asp>
- Maskell, P. & Oram, L. *Sapphire: Canada's answer to space-based surveillance of orbital objects*. Retrieved from [http://www.amostech.com/TechnicalPapers/2008/SSA\\_and\\_SSA\\_Architecture/Maskell.pdf](http://www.amostech.com/TechnicalPapers/2008/SSA_and_SSA_Architecture/Maskell.pdf)
- NanoSat Engineering. (2011). *Colony II Bus payload developer guide version 1.2*. Boeing. Huntington Beach, CA.
- Naval Research Laboratory (NRL). (2011). *CubeSat space/ground interface control document (ICD) version 2.0*.
- Naval Research Laboratory (NRL). (2011). *CubeSat space/ground interface control document (ICD) version 2.1*.

- Preventing a space Pearl Harbor: SBS program to monitor the heavens.* (2010, January 18). Retrieved from Defense Industry Daily website: <http://www.defenseindustrydaily.com/Preventing-a-Space-Pearl-Harbor-SBSS-Program-to-Monitor-the-Heavens-06106/>
- Riot, V., Olivier, S., Perticia, A., Bauman, B., Simms, L., & De Vries, W. (2010). *Real-time space situational awareness initiative CubeSat sensor system engineering overview*. Lawrence Livermore National Laboratory.
- Riot, V., Olivier, S., Perticia, A., Bauman, B., Simms, L., & De Vries, W. (2011a). *Real-time space situational awareness initiative CubeSat sensor system engineering overview version 1.1.10*. Lawrence Livermore National Laboratory.
- Riot, V., Olivier, S., Perticia, A., Bauman, B., Simms, L., & De Vries, W. (2011b). *Real-time space situational awareness initiative CubeSat sensor integrated and post-launch testing*. Lawrence Livermore National Laboratory.
- Riot, V., Carter, D., De Vries, W., Bauman, B., Pertica, A., Simms, L., Olivier, S., Newman, J., Lozada, V., Studholme, M., O'Brien, T., Reed, H., Perez, J., Graves, J., Hill, C., Taylor, B., & Pollock, T. (2011, April 5). *SSA CubeSat critical design review*. Lawrence Livermore National Laboratory.
- Selding, P. B. (2007, November 5). Canada to help U.S monitor space with Sapphire satellite. *Space News*. Retrieved from [http://www.spacenews.com/archive/archive07/sapphire\\_1029.html](http://www.spacenews.com/archive/archive07/sapphire_1029.html)
- Simms, L., Riot, V., De Vries, W., Olivier, S., Pertica, A., Bauman, B., Phillion, D., & Nikolaev, S. (2011, March 17). *Optical payload for the STARE mission*. LLNL-CONF-474234. Lawrence Livermore National Laboratory. Retrieved from <https://e-reports-ext.llnl.gov/pdf/473852.pdf>
- Statement of General C. Robert Kehler Commander United States Strategic Command before the Senate Committee on Armed Services*, (2011). Retrieved from <http://armed-services.senate.gov/statemnt/2011/03%20March/Kehler%2003-29-11.pdf>
- Stokes, G.H., Von Braun, C., Sridharan, R., Harrison, D., & Sharma, J. (1998). *The space-based visible program*. *Lincoln Laboratory Journal*, 11(2), 206 – 238.
- USSTRATCOM Space Control and Space Surveillance*, (2010). Retrieved December 5, 2011 from [http://www.stratcom.mil/factsheets/USSTRATCOM\\_Space\\_Control\\_and\\_Space\\_Surveillance/](http://www.stratcom.mil/factsheets/USSTRATCOM_Space_Control_and_Space_Surveillance/)

THIS PAGE INTENTIONALLY LEFT BLANK

## INITIAL DISTRIBUTION LIST

1. Defense Technical Information Center  
Ft. Belvoir, VA
2. Dudley Knox Library  
Naval Postgraduate School  
Monterey, CA
3. Professor Alan D. Scott  
Naval Postgraduate School  
Monterey, CA
4. Professor James H. Newman  
Naval Postgraduate School  
Monterey, CA
5. Mr. James A. Horning  
Naval Postgraduate School  
Monterey, CA
6. Professor Rudolph Panholzer  
Chairman, Space Systems Academic Group  
Naval Postgraduate School  
Monterey, CA
7. LCDR Henry D. Travis, USN  
Program Officer, 366 Curriculum  
Naval Postgraduate School  
Monterey, CA