



# Acquisition Directorate

---

## Research & Development Center

Report No. CG-D-10-11

# CSSC Fish Barrier Simulated Rescuer Touch Point Results, Operating Guidance, and Recommendations for Rescuer Safety – Final Report

**Distribution Statement A.:** Approved for public release, distribution is unlimited.

September 2011



Homeland  
Security

# **N O T I C E**

This document is disseminated under the sponsorship of the Department of Homeland Security in the interest of information exchange. The United States Government assumes no liability for its contents or use thereof.

The United States Government does not endorse products or manufacturers. Trade or manufacturers' names appear herein solely because they are considered essential to the object of this report.

This report does not constitute a standard, specification, or regulation.



Gary L. Hover  
Aviation Branch Chief  
United States Coast Guard  
Research & Development Center  
1 Chelsea Street  
New London, CT 06320



# CSSC Fish Barrier Simulated Rescuer Touch Point Results, Operating Guidance, and Recommendations for Rescuer Safety – Final Report

## Technical Report Documentation Page

1. Report No. CG-D-10-11		2. Government Accession Number		3. Recipient's Catalog No.	
4. Title and Subtitle CSSC Fish Barrier Simulated Rescuer Touch Point Results, Operating Guidance, and Recommendations for Rescuer Safety – Final Report				5. Report Date September 2011	
				6. Performing Organization Code Project No. 1022	
7. Author(s) Michael Slater, Norbert Yankielun, John Parker, M. J. Lewandowski				8. Performing Organization Report No. RDC UDI No. 1142	
9. Performing Organization Name and Address U.S. Coast Guard Research and Development Center 1 Chelsea Street New London, CT 06320				10. Work Unit No. (TRAIS)	
				11. Contract or Grant No. Contract HSCG32-10-D-R00021/ Task Order HSCG32-10-J-300002	
12. Sponsoring Organization Name and Address U.S. Department of Homeland Security Commandant (CG-534), (CG-5213) United States Coast Guard 2100 Second St. SW Washington, DC 20593-0001				13. Type of Report & Period Covered Final	
				14. Sponsoring Agency Code Commandant (CG-534), (CG-5213) U.S. Coast Guard Headquarters Washington, DC 20593-0001	
15. Supplementary Notes The R&D Center's technical point of contact is Marion J. Lewandowski, 860-271-2692, email: <a href="mailto:M.J.Lewandowski@uscg.mil">M.J.Lewandowski@uscg.mil</a> .					
16. Abstract (MAXIMUM 200 WORDS) <b>Purpose:</b> The Chicago Sanitary and Ship Canal (CSSC) has electric dispersal barriers in operation to prevent the spread of aquatic nuisance species. The experiment was to better understand what would actually occur during a rescue in the electrified waters with three barriers energized. An additional purpose was to identify any methods, devices, or operating guidance to prevent potential harm to a rescuer. <b>Methods:</b> Voltage measurements under controlled conditions were taken during transits in the regulated navigation area using aluminum and fiberglass-hulled vessels to determine the current a rescuer would be exposed to. Monitoring of voltage levels and vessel position continuously took place throughout the transit. Devices evaluated for potential rescuer use included life rings/throw lines and non-conducting boat hooks. Measurements taken along the canal bank assisted in determining currents a rescuer from shore would experience. <b>Results:</b> Under certain operating conditions and with non-conductive apparatus, rescuers may be able to safely assist person in the water to move them away from the barriers. The rescuer and victim must be isolated from a vessel metal hull for recovery, and use of a fiberglass-hulled vessel provides improved protection over an aluminum-hulled vessel. Some areas of the canal upstream of Barriers IIA and IIB may support a shore-side rescue.					
17. Key Words Electric fish barrier, electrified water, rescue, CSSC, Asian carp, Barrier IIA, Barrier IIB, demonstration barrier			18. Distribution Statement Distribution Statement A. Approved for public release, distribution is unlimited.		
19. Security Class (This Report) UNCLAS//Public		20. Security Class (This Page) UNCLAS//Public		21. No of Pages 60	22. Price



**This page intentionally left blank.**



## **ACKNOWLEDGEMENTS**

The Coast Guard Research & Development Center (RDC) would like to express deep gratitude to the U.S. Army Corps of Engineers (USACE) Chicago District Engineer staff for their wholehearted support to the field-test team while working in the vicinity of the Chicago Sanitary and Ship Canal (CSSC) barrier. The RDC and Science Applications International Corporation (SAIC) greatly appreciate the technical assistance provided to help expedite data collection, especially the on-site effort to allow clear access to the West bank of the Canal, help with solving data recording power supply and equipment mobility issues, and the frequent changing of barrier operating parameters during data collection runs.

The RDC also recognizes the support of the local Coast Guard units, including Sector Lake Michigan, Marine Safety Unit Chicago, and Station Calumet Harbor, and the Illinois Department of Natural Resources for providing canal closure and patrol efforts that played a significant contribution to the field team safety during in-the-water data collection efforts.



**This page intentionally left blank.**



## **EXECUTIVE SUMMARY**

The U.S. Army Corps of Engineers (USACE) constructed a demonstration electric fish barrier (Barrier I) across the Chicago Sanitary and Ship Canal (CSSC) at river mile 296.5 and first energized it in 2002. USACE initially constructed the demonstration barrier to prevent dispersal of aquatic nuisance species, including the round goby and white perch, to and from the Great Lakes and Mississippi River Basins. Additionally, the barrier is intended to counter an invasive species threat from the Asian carp, which is seen as a significant impact to native species in the Great Lakes. Various species of Asian carp were originally imported into the U.S. in the early 1970's for use in Arkansas fish farms to improve water quality and increase fish production.

With the success of the demonstration barrier, USACE determined it necessary to construct a permanent barrier (Barrier II) in two phases, IIA and IIB. Barriers IIA and IIB reached final operational status in 2009 and June 2011, respectively. The combined electrical capabilities of Barriers IIA/B exceed Barrier I (demonstration barrier) electrical capability.

USACE conducted in-water testing in 2008 on barge operations in the canal barrier zone, with efforts made to evaluate the risk to vessels and humans from electrified waters. Under contract by USACE, the Navy Experimental Diving Unit (NEDU) published a study that found that voltage gradients measured in the CSSC could be life threatening, and could pose a significant risk to humans immersed in the canal near the fish barriers. USACE conducted additional in-water testing through 2011. As a result of these various tests and studies, specific precautions are required of all vessels and personnel transiting the barriers from river mile 296.1 through 296.7, from Romeo Road Bridge to the aerial pipeline arch. Testing to date has also (1) characterized the electrical voltage field in the canal, (2) determined its effects on surface vessels and barges, (3) evaluated electrical contacts among vessels comprising a long tow, and (4) evaluated the potential for sparking during barge fleeting operations or in the case of an allision.

Coast Guard Sector Lake Michigan (SLM) is the Coast Guard operational field commander with overall responsibility for marine safety and maritime search and rescue (SAR) in the area of the electrified barrier. After the initial safety studies, SLM requested the Coast Guard Research & Development Center (RDC) to assist in developing a CSSC Fish Barrier SAR policy. RDC conducted a short-term project that reviewed and summarized the previous work. Recommendations of the project were to further investigate SAR mission capabilities and gaps for electrified water conditions and to identify or develop specialized SAR equipment (non-conductive poles, rescue loops or devices) for safe retrieval of persons in the water (PIWs).

The primary purpose of this study is to focus on the ability to provide safe rescuer response actions to assist a PIW. At certain levels, electrical current through the human body can have a range of effects: from a tingle sensation at the threshold of perception, to uncontrollable muscle contractions, to direct effects on the heart. This study focuses on assessing possible conditions that would be encountered during a rescue, specifically the amount of electrical current potentially experienced by the rescuer.

RDC and Science Applications International Corporation (SAIC) designed and conducted a series of tests at the CSSC on 17, 18, and 19 November, 2010. These tests followed a variety of specific data acquisition and test apparatus set-up conditions from a formal test plan to assess whether identified rescue techniques are safe and effective for use in a real rescue scenario within the electrified area. A series of follow-on tests



## CSSC Fish Barrier Simulated Rescuer Touch Point Results, Operating Guidance, and Recommendations for Rescuer Safety – Final Report

---

were designed and conducted at the CSSC on 18, 19, 20, and 21 July, 2011 to better understand rescue methods, including testing with a fiberglass-hulled vessel. Testing in July 2011 included conditions with Barriers IIA and IIB operating at 2.3 volts/inch.

Experimental efforts focused on measuring electrical current flow through a simulated human rescuer under each touch-point condition outlined in the test plan. A series of detailed measurements along the west bank of the CSSC quantified the effects to a potential rescuer conducting a shore-side rescue, and to identify areas that might be suitable for shore-side rescue.

Data analysis showed that significant electrical currents could be encountered within the electrified area of the CSSC and, without significant precautions, could endanger rescue personnel. Voltage levels in the canal were of sufficient strength, and with a sufficient level of electrical current capacity, to impart potentially harmful electrical currents to rescuers. In general, non-conductive or resistive materials, such as rubber, plastic and fiberglass, are effective in reducing the electrical current risk to a rescuer, so long as rescuers understand the electrical current paths, and take actions to avoid or minimize them. A fiberglass-hulled vessel provides good protection for rescuers if precautions are taken to avoid touching metallic items on the vessel that are in contact with the water, such as the motor or motor brackets, and would include other items such as over-the-side ladders or railings.

Additionally, a rescuer on shore could encounter significant electrical currents within the electrified area of the CSSC and, without precautions, could put themselves or others in danger. However, there are *limited* locations along the West bank of the canal where a rescuer might not encounter a measurable electrical current by making contact with a PIW. As with rescue from a vessel, a potential rescuer must take many of the same precautions, including use of non-conductive equipment and isolation materials, and avoid contact with metallic objects such as fence posts, sign posts, or electrical boxes which were shown during testing to provide a low-resistance ground path for electrical current, thus creating a higher risk of shock hazard.

### WARNING

**Under no circumstances should a rescuer enter or immerse any part of their body directly into the electrified waters in the CSSC. A rescuer should not make contact with any PIW (in the electrified area) unless the rescuer is electrically isolated from the PIW. Any attempt at rescue in electrified water conditions is inherently hazardous. This report offers recommendations to *mitigate* hazards to rescuers, but not eliminate them. Nothing in this report should be construed that rescue in electrified water is anything but a hazardous undertaking.**





**TABLE OF CONTENTS**

**ACKNOWLEDGEMENTS ..... v**

**EXECUTIVE SUMMARY ..... vii**

**LIST OF FIGURES ..... xi**

**LIST OF TABLES ..... xii**

**LIST OF ACRONYMS AND SYMBOLS ..... xiii**

**1 INTRODUCTION ..... 1**

**2 METHODOLOGY ..... 2**

    2.1 Mobilization and Test Set-up ..... 2

    2.2 Data Acquisition Set-up ..... 5

        2.2.1 Sensors ..... 6

        2.2.2 Rescue Test Apparatus ..... 8

        2.2.3 Electrical Sensing and Recording ..... 10

        2.2.4 Position Instrumentation ..... 11

    2.3 Ancillary Data ..... 13

        2.3.1 USACE Barrier Data Logs ..... 13

        2.3.2 Water Conductivity Measurements ..... 13

**3 DATA COLLECTION AND ANALYSIS ..... 14**

    3.1 Data Collection Overview ..... 14

    3.2 Observations ..... 15

        3.2.1 Test Condition 1: Free-field Current ..... 15

        3.2.2 Test Condition 2: Rescue Vessel Recovery Touch-point Current ..... 19

        3.2.3 Test Condition 3: Shore Recovery Touch-point Current ..... 22

        3.2.4 Test Condition 6: Rescue Apparatus ..... 31

**4 ELECTRIC CURRENTS AND THE HUMAN BODY ..... 31**

    4.1.1 An Illustration ..... 33

    4.1.2 Cardiac Physiology ..... 33

**5 DISCUSSION OF RESULTS ..... 34**

**6 CONCLUSIONS ..... 35**

**7 RECOMMENDATIONS ..... 36**

**8 REFERENCES ..... 37**

**APPENDIX A MEASUREMENT TEST BOX SCHEMATIC ..... A-1**

**APPENDIX B BARRIER ELECTRICAL OPERATING PARAMETERS ..... B-1**

**APPENDIX C SHORE TOUCH POINT DATA LOG ..... C-1**



**This page intentionally left blank.**



**LIST OF FIGURES**

Figure 1. L&R aluminum test vessels..... 2

Figure 2. Towed free-field sensor array apparatus loaded on test vessel. .... 3

Figure 3. General arrangement of Safety Zone and major landmarks..... 4

Figure 4. Lindahl Marine Contractors fiberglass test vessel. .... 4

Figure 5. Shore touch-point data acquisition equipment set-up. .... 5

Figure 6. Free-field towed array apparatus during tow..... 6

Figure 7. Configuration of electrode sensor array with color-coded electrode pairs..... 7

Figure 8. Shore touch-point wet-end electrode..... 8

Figure 9. Shore touch-point ground electrode. .... 8

Figure 10. Polypropylene rope test. .... 9

Figure 11. Non-conductive rescue hook test..... 9

Figure 12. Electric field recording system block diagram. .... 10

Figure 13. Electrical sensing test box physical set-up. .... 11

Figure 14. GPS receivers and loggers on deck of test vessel..... 12

Figure 15. Peak free-field electrical current (mA) between horizontal electrodes, 72” apart, oriented parallel to vessel track, 2.3 volts/inch. .... 17

Figure 16. Peak free-field electrical current (mA) between horizontal electrodes, 72” apart, oriented parallel to vessel track, 2.0 volts/inch. .... 18

Figure 17. Peak rescue vessel electrical current (mA), aluminum hull, 2.3 volts/inch. .... 20

Figure 18. Peak rescue vessel electrical current (mA), aluminum hull, 2.0 volts/inch. .... 21

Figure 19. Peak rescue vessel electrical current (mA), fiberglass hull, 2.3 volts/inch. .... 23

Figure 20. Peak rescue vessel electrical current (mA), fiberglass hull, 2.0 volts/inch. .... 24

Figure 21. Peak rescue vessel electrical current (mA), fiberglass hull, metal motor mount, 2.0 volts/inch. .... 25

Figure 22. Results for shore touch-point current, “earth ground”, all barriers operating. .... 27

Figure 23. Results for shore touch-point current, “metallic ground”, all barriers operating. .... 28

Figure 24. Results for shore touch-point current, “earth ground”, Barrier IIA “off”. .... 29

Figure 25. Results for shore touch-point current, “metallic ground”, Barrier IIA “off”. .... 30

Figure A-1. Measurement test box schematic diagram. .... A-1



**LIST OF TABLES**

Table 1. Daily mobilization schedule. .... 5  
Table 2. GPS data recording format. .... 12  
Table 3. Canal conductivity. .... 13  
Table 4. Test condition log. .... 14  
Table 5. Test Condition 1, free field test results. .... 16  
Table 6. Test Condition 2, vessel touch-point results. .... 19  
Table 7. Test Condition 6, rescue apparatus results. .... 31  
Table B-1. Barrier IIA nominal electrical parameters (18-21 July 2011). .... B-1  
Table B-2. Barrier IIB nominal electrical parameters (18-21 July 2011). .... B-1  
Table C-1. Test Condition 3 highest peak currents, all barriers operating. .... C-1  
Table C-2. Test Condition 3 highest peak currents, demonstration barrier and Barrier IIB only. .... C-2



## **LIST OF ACRONYMS AND SYMBOLS**

μS/cm	MicroSiemens per centimeter
A/D	Analog-to-digital
AC	Alternating current
amp	Ampere
ATV	all-terrain vehicle
AWG	American Wire Gauge
COTP	Captain of the Port
CSSC	Chicago Sanitary and Ship Canal
DC	Direct current
EKG	Electrocardiogram
GMT	Greenwich mean time
GPS	Global Positioning System
HDOP	Horizontal dilution of position
Hz	Hertz
ID	Identification
IL	Illinois
kHz	Kilohertz
kW	KiloWatt
L&R	Lakes & Rivers Contracting, Inc.
mA	Milliampere
mph	Mile per hour
ms	Millisecond
NEDU	Navy Experimental Diving Unit
PIW	Person in the water
RDC	Research & Development Center
RF	Radio frequency
rms	Root mean square
SAIC	Science Applications International Corporation
SAR	Search and rescue
SLM	Sector Lake Michigan
TSS	Three-conductor, shielded, shipboard
U.S.	United States
UPS	Uninterruptible power supply
USACE	United States Army Corps of Engineers
USB	Universal serial bus
USCG	United States Coast Guard
V/in	Volts/inch
VAC	Volts alternating current
VDC	Volts direct current



**This page intentionally left blank.**



## 1 INTRODUCTION

The United States Army Corps of Engineers (USACE) operates a series of electric barriers in the Chicago Sanitary and Ship Canal (CSSC) in an effort to reduce the risk of inter-basin transfer of fish between the Great Lakes and Mississippi River Basins via the CSSC. USACE installed Barrier I (Demonstration) in 2002; it operates at a nominal level of 1 volt/inch, with a 5 Hertz (Hz) repetition rate and 4 milliseconds (ms) pulse duration. It was initially constructed to prevent dispersal of aquatic nuisance species, including the round goby and white perch, to and from the Great Lakes and Mississippi River Basins (Reference 1). The barrier is also intended to counter an invasive species threat from the Asian carp, which is seen as a significant threat to native species in the Great Lakes. Various species of Asian carp (Reference 2) were originally imported into the United States (U.S.) in the early 1970's for use in Arkansas fish farms to improve water quality and increase fish production (Reference 2).

USACE conducted testing in 2008 on barge operations in the canal barrier zone with efforts made to evaluate the risk to vessels and humans from electrified waters (Reference 3). Under contract by USACE, the Navy Experimental Diving Unit (NEDU) published a study that found that voltage gradients measured in the CSSC could be life threatening, and could pose a significant risk to humans immersed in the canal near the fish barriers (Reference 4). USACE conducted additional in-water testing through 2011 (Reference 5). As a result of these various tests and studies, specific precautions are required of all vessels and personnel transiting the barriers from river mile 296.1 through 296.7, from Romeo Road Bridge to the aerial pipeline arch. Testing to date has also (1) characterized the electrical voltage field in the canal barrier zone, (2) determined its effects on surface vessels and barges, (3) evaluated electrical contacts among vessels comprising a long tow and (4) evaluated the potential for sparking during barge fleeting operations or in the case of an allision. Reference 5 provides comprehensive results from these tests.

Coast Guard Sector Lake Michigan (SLM) is the Coast Guard operational field commander with overall responsibility for marine safety and maritime search and rescue (SAR) in the area of the electrified barrier. After the initial safety studies (Reference 6), SLM requested the RDC to assist in developing a CSSC Fish Barrier SAR policy. RDC conducted a short-term project that reviewed and summarized the previous work. Recommendations of the project were to further investigate SAR mission capabilities and gaps for electrified water conditions and to identify or develop specialized SAR equipment (non-conduction poles, rescue loops or devices) for safe retrieval of persons in the water (PIWs) (References 7 and 8).

With the success of the demonstration barrier, USACE determined it necessary to construct a permanent barrier (Barrier II) in two phases, IIA and IIB. Barrier IIA, a permanent barrier which is larger and more powerful than the demonstration barrier, has been operational since 2009, initially with the same operational parameters as the demonstration barrier; then in August 2009, USACE increased the strength of the electric field produced by Barrier IIA to 2.0 volts/inch, with a 15 Hz repetition rate and 6.5 ms pulse duration. USACE has completed construction on a third barrier, Barrier IIB, which was energized during the July 2011 data collection period. Barriers IIA and IIB were operated at 2.0 and 2.3 volts/inch during specific tests identified to evaluate and compare results between the two operational conditions. This study is not intended to characterize the electric field itself, but to focus on the effects of the field on potential rescuers and rescue scenarios. Section 4 provides a brief tutorial on the effect of electric currents on the human body.





## 2 METHODOLOGY

We conducted all testing in accordance with an experiment test plan (Reference 7) that laid out the test conditions, resources, and experimental apparatus for each scenario. We conducted testing from vessels in the canal and from shore along the west bank. Prior to testing each day, the Test Director provided a briefing to all embarked personnel, and reviewed communications and safety procedures. We tested barriers at 2.0 volts/inch and 2.3 volts/inch. Due to safety considerations for other traffic on the CSSC at the higher voltage conditions, the canal was shut down to traffic during specific time periods each test day. We conducted all test vessel operations in accordance with a regulatory waiver from the United States Coast Guard (USCG) Captain of the Port (COTP) Lake Michigan. Coast Guard Sector Lake Michigan (SLM) and Illinois Department of Natural Resources stationed vessels at either end of the Safety Zone during all test days for canal closure enforcement and immediate response, if required.

### 2.1 Mobilization and Test Set-up

We mobilized for each test day depending on the specific needs to achieve test conditions in the plan. On 18 and 19 July we mobilized aluminum vessels from the Lakes & Rivers Contracting, Inc. (L&R) facility, Lemont, Illinois (IL). We used an enclosed aluminum-hulled vessel for free-field testing on 18 July (see Figure 1, left photo), which was the same test vessel used during November 2010 testing (Reference 8). A mechanical issue with this vessel prevented continuation of this testing on the following day, so an open cockpit aluminum-hulled vessel was used for testing on 19 July (see Figure 1, right photo).



Figure 1. L&R aluminum test vessels.

We configured a towed sensor array apparatus (to be described in section 2.2) using a commercial pontoon boat, with outriggers and keel features to attach electrodes. We loaded the apparatus onto the test vessel, and secured it to the deck (Figure 2). We stowed the data recording electronics inside the cabin, and powered the system using 120 volts alternating current (VAC) conditioned power from a commercial uninterruptible power supply (UPS) fed by the output of a small gasoline-powered portable generator. With the open cockpit vessels, we mounted a temporary awning to protect the data recording equipment and crew from the sun.



## CSSC Fish Barrier Simulated Rescuer Touch Point Results, Operating Guidance, and Recommendations for Rescuer Safety – Final Report

---



Figure 2. Towed free-field sensor array apparatus loaded on test vessel.

We transited to an electrically safe area north of the aerial pipeline arch and deployed the towed array apparatus into the water and attached it to the aft railing of the test vessel with a polypropylene tow rope. Next, we confirmed the operation of the sensor array and data acquisition system and proceeded to perform the scheduled survey with the vessel maintaining a speed (measured by a Global Positioning System (GPS)) in the range of approximately 0.5 to 3.0 miles per hour (mph). This speed permitted high spatial density data acquisition. We arranged the transects to acquire data along tracks near the eastern and western banks and in the mid-channel of the canal within the barrier zone. The canal was closed to traffic during testing, enabling uninterrupted data collection. We exited the barrier area to make configuration changes to the sensor and test conditions in accordance with the experiment test plan (Reference 7). Figure 3 shows the general arrangement of the barrier Safety Zone with major landmarks.

We tested using a fiberglass-hulled vessel provided by Lindahl Marine Contractors on 20 July (see Figure 4), and loaded test equipment pier-side at Hanson Materials Services in Romeoville.



# CSSC Fish Barrier Simulated Rescuer Touch Point Results, Operating Guidance, and Recommendations for Rescuer Safety – Final Report



Figure 3. General arrangement of Safety Zone and major landmarks.



Figure 4. Lindahl Marine Contractors fiberglass test vessel.





# CSSC Fish Barrier Simulated Rescuer Touch Point Results, Operating Guidance, and Recommendations for Rescuer Safety – Final Report

The team conducted shore touch-point measurements from the west canal bank on 21 July, and did not use a test vessel for support. Instead, we loaded the data acquisition equipment into an all-terrain vehicle (ATV), and connected to a gasoline-powered generator in a small trailer (see Figure 5). We maneuvered the ATV along the roadway along the canal, but outside the security fence. We routed an insulated sensor cable from the ATV to the bank of the canal where we connected it to the wet end and grounding electrodes.



Figure 5. Shore touch-point data acquisition equipment set-up.

Table 1 summarizes the daily mobilization schedule for the July 2011 test series.

Table 1. Daily mobilization schedule.

Test Date	Test Vessel, Location, and Condition
18 July, 2011	L&R enclosed aluminum hull, free-field with towed apparatus; Mobilized from L&R Contracting at Lemont, IL
19 July, 2011	L&R open aluminum hull, rescue apparatus; Mobilized from L&R Contracting at Lemont, IL
20 July, 2011	Lindahl Marine, enclosed fiberglass hull, rescue apparatus; Mobilized from Hanson Materials Services near Romeoville, IL
21 July, 2011	No vessel used, shore touch-point current, west bank; Mobilized at CSSC, west bank location

## 2.2 Data Acquisition Set-up

We used a similar instrumentation set-up as was used during the November 2010 data collection period (Reference 8). The apparatus and data acquisition set-up also incorporated recommendations and lessons learned from USACE experience in electric field data collection in the CSSC. The electronics signal conditioning, sensing, and recording equipment was the same for both test periods. The primary difference with the new set-up was the in-water sensing configuring, including the use of a commercial pontoon boat as the towed sensor array for free-field testing (see Figure 6). The new fixture allowed free-field measurements of a simulated PIW away from the tow vessel, and furthermore provided simultaneous sensing of horizontal field strength conditions in two orthogonal directions (along the canal, parallel the test vessel track, and side-to-side in the canal, perpendicular to the test vessel track.)



Figure 6. Free-field towed array apparatus during tow.

## 2.2.1 Sensors

### 2.2.1.1 *Input Electrodes, In-water Testing*

Input electrodes consisting of 1/2" diameter, 6" long copper rods were wired to separate conductors of a shielded, commercially available, underwater-rated electrical cable (three-conductor, shielded, shipboard cable (TSS-2), 18 American Wire Gauge (AWG) stranded copper). Electrode pairs shared a single signal cable to minimize interference from external sources during testing. We polished the surface of electrodes with fine grit sandpaper prior to use to ensure the best electrical continuity between the water and electrode by removing any copper oxide. This electrode configuration differed from the previous (July 2010) configuration, in which copper rod electrodes were encapsulated in a conductive diatomaceous mixture to provide an approximate bulk resistivity of a PIW. We observed during the November 2010 testing that we could more closely control the simulated resistivity of a PIW using series resistors in the signal path.

We mounted six electrodes to a wooden framework mounted to the towed pontoon boat frame to create three pairs of electrodes (Figure 7). We arranged one pair of electrodes to provide 72" spacing fore-and-aft, nominally 12" below the water surface, a second pair to provide 72" spacing side-to-side, also 12" below the water surface, and the third pair 48" vertically, with the upper electrode 12" beneath the surface, and the other 60" below the surface. We used this configuration to assess the electrical exposure to a PIW swimming along the canal, across the canal, or in a vertical position. (Due to hydrodynamic limitations of the towed platform, we were not able to attain the originally desired 72" vertical spacing.) We twisted pairs of 1000 V rated electrode wires, secured them to the tow rope, and terminated them to the TSS-2 cable located on the back desk of the test vessel. We labeled each wire pair with colored electrical tape (green, yellow, and red) to provide ease of identification for each pair of electrodes: green for 72" side-to-side orientation, yellow for 72" fore-aft orientation, and red for 48" foot vertical separation.



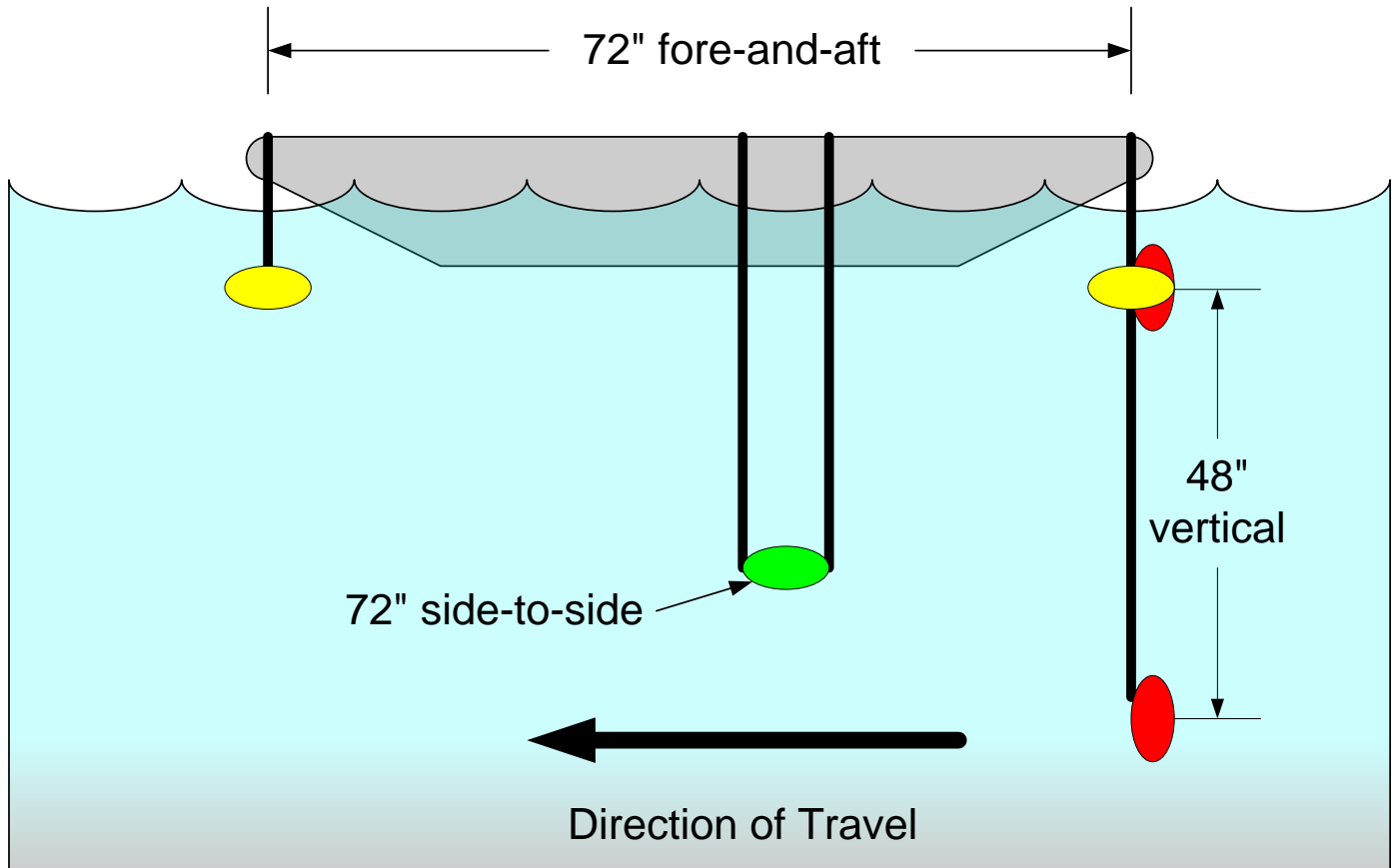

Figure 7. Configuration of electrode sensor array with color-coded electrode pairs.

#### 2.2.1.2 Input Electrodes, Shore Touch-point Testing

For the wet-end electrode, we arranged a bare copper electrode for our positive lead (see Figure 8, left photo) similar to those used for in-water testing, with floats (see Figure 8, right photo) rigged to maintain an electrode depth in water of approximately 12". Our ground electrode was comprised of an aluminum plate and flexible copper grounding strap (see Figure 9, left photo). For testing, we moistened the vegetation and soil immediately beneath the plate at each test location with fresh water, and weighted the plate with a 2.5 gallon water jug (Figure 9, right photo). Both electrodes were cabled to the TSS-2 cable using 1000 V rated insulated wire. We fastened the wet electrode to a monofilament fishing line and lowered it into the water at each test location with a fiberglass fishing rod.





Figure 8. Shore touch-point wet-end electrode.



Figure 9. Shore touch-point ground electrode.

### 2.2.2 Rescue Test Apparatus

We tested two types of rescue apparatus from the aluminum and fiberglass-hulled test vessels: (1) polypropylene rope to simulate towing a PIW; and (2) a non-conductive rescue hook to simulate grasping or towing a PIW. A commercially available life-ring rope bag (Stearns part number #I023ORG-00-000) with a 3/8" open-braid polypropylene line served as the test line for the poly rope test. The wet-end of the poly rope was wrapped around a copper electrode, and submerged beneath the life ring for towing. The dry end of the rope was wrapped around a metal wrench, and terminated into the electrical sensing instrumentation. The ground lead was connected to the test vessel hull. The test vessel towed the simulated PIW and life-ring assembly approximately one boat length (Figure 10) behind it. A length of the polypropylene line approximately 25' long was predominately out of water during the tow. We submerged the rope prior to the test to ensure it was as wet as possible during the electrical current testing.



## CSSC Fish Barrier Simulated Rescuer Touch Point Results, Operating Guidance, and Recommendations for Rescuer Safety – Final Report

---



Figure 10. Polypropylene rope test.

We fitted the non-conductive rescue hook to a copper electrode on the wet end (hook end) to simulate the PIW, and lashed it to the life ring to provide flotation during towing. The dry end was wrapped in foil to provide some continuity with the pole, and the electrically isolated from the test vessel with switchgear mat and a wooden strut (see Figure 11).



Figure 11. Non-conductive rescue hook test.



### 2.2.3 Electrical Sensing and Recording

The data acquisition collection system included a Dell D520 laptop computer, a 4-channel analog-to-digital (A/D) converter, high-voltage differential probes, measurement resistors, and input electrodes. Figure 12 depicts a top-level block diagram of the data acquisition system. We wired the input electrodes to the data acquisition system inputs via submersible electrical cables. We used the electronics, which were housed in a weather-proof case, to sample, digitize, and store collected data onto the laptop hard drive for real-time monitoring, playback, and analysis.

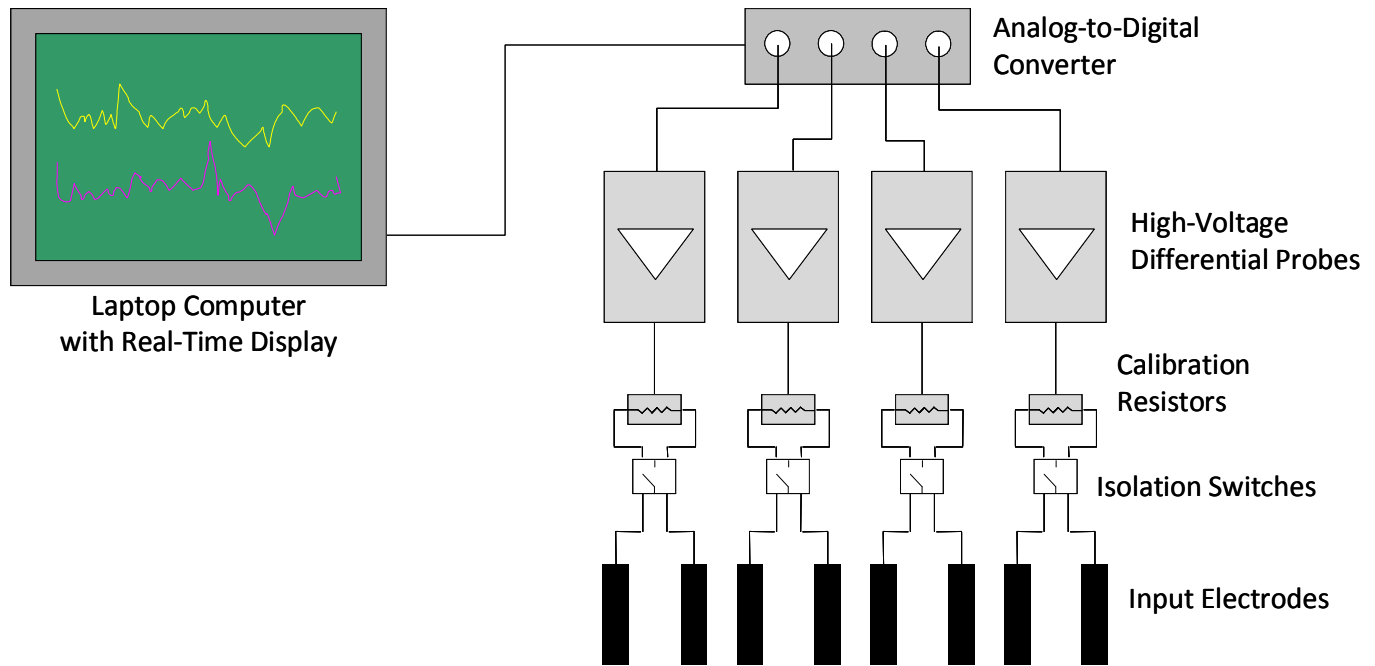

Figure 12. Electric field recording system block diagram.

We wired three-pole, double-throw switches to the input side of the test box to enable the user to completely disconnect and isolate the test box from electrodes in the water if required for testing or system reconfiguration. We used these switches between test condition set-ups, and they were necessary during troubleshooting of the system while deployed. We used Tektronix P5200 High-Voltage Differential Probes for each channel of measurement for voltage stepdown and circuit protection and personnel safety. Each P5200 contains optical isolation circuitry that prevents excessive voltages on the signal side of the unit that could damage the low voltage circuits on the recorder. This protection was necessary due to the high voltages produced by the barriers. The P5200s were powered by a 9 volts direct current (VDC) supply and were configured for a 1:500 stepdown rate.

We measured voltage levels across commercial high-power resistors of a nominal 500 ohm resistance. The high power rating (200 watts) allowed safe use and substantial power dissipation when exposed to high voltages from the barrier. We wired the measurement resistors in series with the input electrodes. Figure 13 shows the measurement test box; Appendix A provides an electrical schematic.



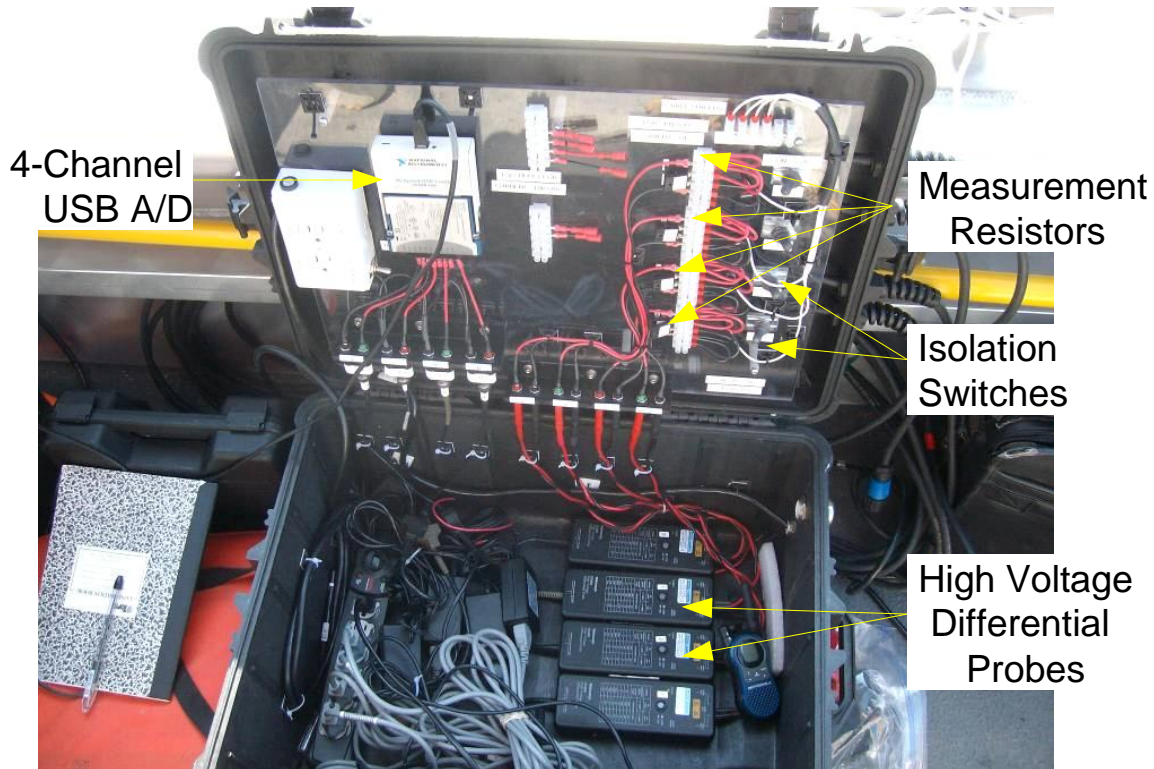

Figure 13. Electrical sensing test box physical set-up.

We wired the signals for each sensor to individual channels of a differential input, 4-channel National Instruments USB-9215A universal serial bus (USB)-powered A/D unit, which digitized the data at a 10 kilohertz (kHz) sampling rate and transmitted the digital data to the laptop computer. We equipped the laptop computer with customized automated signal processing LabVIEW™ software that received the data and formatted it for storage in a binary file format on the laptop hard drive. Data were continuously sampled and stored at 5-minute periods for all test conditions. We programmed the recording system to autonomously record data for a continuous 5-minute period throughout the testing period. We saved data files in a time-tagged format to allow reconstruction with the vessel positional information.

#### **2.2.4 Position Instrumentation**

Portable GPS receivers with built-in data logging capabilities provided positional information during periods of data collection. Two units periodically recorded test vessel position as a function of time, one unit as the primary, and the other as a backup. We staged GPS units on the deck of the test vessel (see Figure 14).

**CSSC Fish Barrier Simulated Rescuer Touch Point Results, Operating Guidance, and Recommendations for Rescuer Safety – Final Report**



Figure 14. GPS receivers and loggers on deck of test vessel.

During the survey, two onboard GPSs continually and simultaneously recorded the test vessel position at a rate of approximately 10 to 12 times a minute. Data recorded by the GPS included: latitude (DD.DDDDDD format), longitude (DD.DDDDDD format), date (ddmmyy), time (hhmmss) relative to Greenwich mean time (GMT), vessel speed (mph), and vessel track (degrees magnetic), and other data. Table 2 shows the basic recording format with a segment of run data from the 18 July testing. GPS positions were recorded using WGS84 datum. We computed positional graphs of test vessel transects each run day for each test condition and time-synchronized them to the recorded electric field data.

Table 2. GPS data recording format.

Fix	Latitude (N)	Longitude (W)	Time	Date	Speed	Vessel Track	Altitude	HDOP*	Satellites
D	41.64565	88.05968	154222	180711	2.1	006	587	1.2	10
D	41.64568	88.05967	154226	180711	2.2	007	587	1.2	10
D	41.64572	88.05967	154230	180711	2.2	008	587	1.3	9
D	41.64577	88.05965	154236	180711	2.2	005	587	1.4	10
D	41.64582	88.05965	154240	180711	2.2	003	587	1.1	10

\*horizontal dilution of position

# CSSC Fish Barrier Simulated Rescuer Touch Point Results, Operating Guidance, and Recommendations for Rescuer Safety – Final Report

The GPS latitude and longitude data acquired during each survey were synchronized in time with the recorded electrical data files, and plotted in ArcView over satellite imagery.

## 2.3 Ancillary Data

In addition to electronically recorded data, barrier operational conditions and water conductivity data were also acquired.

### 2.3.1 USACE Barrier Data Logs

USACE personnel at each barrier logged operational conditions of each barrier, including the voltage, current, and power levels, as well as pulse length and pulser frequency. Conductivity measurements of the canal water and nominal in-water voltages were also logged. Appendix B provides summary values of the barrier operating conditions during the test days for Barriers IIA and IIB.

### 2.3.2 Water Conductivity Measurements

We used a commercial hand-held conductivity meter and probe to measure the electrical conductivity of the water in the canal each test day. Table 3 shows measured values which were taken over the side of the test vessel outside the electrified zone near the pipeline arch, at the water surface. Water conductivity differed slightly each day, and values agreed within a few percentage points. Measured values were similar to those logged by USACE personnel taken at the same time. Values were logged periodically throughout each test day by USACE personnel, and values did not vary more than approximately 8% over the course of the week.

Table 3. Canal conductivity.

Date (2011)	Time	Measured Conductivity ( $\mu\text{S}/\text{cm}^*$ )	Conductivity from Barrier IIA Logs <sup>1</sup> ( $\mu\text{S}/\text{cm}$ )
18 July	11:45 AM	749	818
19 July	08:43 AM	747	843
20 July	09:05 AM	815	818
21 July	11:00 AM	N/A <sup>2</sup>	827

\*microSiemens per centimeter

<sup>1</sup>Logged at approximately the same time as the measured values.

<sup>2</sup>Measurement of the canal conductivity from the west canal bank was not possible due to safety constraints in gaining access to the canal from the bank.

# CSSC Fish Barrier Simulated Rescuer Touch Point Results, Operating Guidance, and Recommendations for Rescuer Safety – Final Report

## 3 DATA COLLECTION AND ANALYSIS

### 3.1 Data Collection Overview

We performed all testing in accordance with the experiment test plan (Reference 7). Table 4 provides a summary of the test conditions conducted, and start/stop times for each condition.

Table 4. Test condition log.

Test Condition	Test Condition Description	Barrier IIA (V/in*)	Barrier IIB (V/in)	Start Date/Time	Finish Date/Time
1	Free-field current, towed sensor array	2.3	2.0	7/18/2011 10:32 AM	7/18/2011 10:49 AM
		2.3	2.3	7/18/2011 10:49 AM	7/18/2011 11:24 AM
		2.3	2.3	7/18/2011 13:13 PM	7/18/2011 13:53 PM
1	Free-field current, towed sensor array	2.0	2.0	7/18/2011 13:55 PM	7/18/2011 14:51 PM
2	Rescue vessel recovery touch-point current, aluminum hull	2.3	2.3	7/19/2011 09:05 AM	7/19/2011 10:25 AM
2	Rescue vessel recovery touch-point current, aluminum hull	2.0	2.0	7/19/2011 10:30 AM	7/19/2011 12:05 AM
6A	Polypropylene line, aluminum hull	2.3	2.3	7/19/2011 13:18 PM	7/19/2011 13:55 PM
6C	Non-conductive rescue hook, aluminum hull	2.3	2.3	7/19/2011 14:23 PM	7/19/2011 14:49 PM
6C	Non-conductive rescue hook, aluminum hull	2.0	2.0	7/19/2011 14:50 PM	7/19/2011 15:20 PM
2	Rescue vessel recovery touch-point current, fiberglass hull	2.3	2.3	7/20/2011 09:09 AM	7/20/2011 9:40 AM
6C	Non-conductive rescue hook, fiberglass hull	2.3	2.3	7/20/2011 10:27 AM	7/20/2011 10:50 AM
6A	Polypropylene line, fiberglass hull	2.3	2.3	7/20/2011 13:05 PM	7/20/2011 13:28 PM
6A	Polypropylene line, fiberglass hull	2.0	2.0	7/20/2011 13:35 PM	7/20/2011 13:51 PM
6C	Non-conductive rescue hook, aluminum hull	2.0	2.0	7/20/2011 14:02 PM	7/20/2011 14:16 PM
2	Rescue vessel recovery touch-point current, fiberglass hull	2.0	2.0	7/20/2011 14:22 PM	7/20/2011 14:38 PM
2	Rescue vessel recovery touch-point current, fiberglass hull, motor mount	2.0	2.0	7/20/2011 14:38 PM	7/20/2011 14:56 PM
3	Shore recovery touch-point current	2.3	2.3	7/21/2011 07:57 AM	7/21/2011 10:56 AM
		2.3	2.3	7/21/2011 13:10 PM	7/21/2011 13:38 PM
		0.0	2.3	7/21/2011 13:48 PM	7/21/2011 15:53 PM

\*volts/inch





# CSSC Fish Barrier Simulated Rescuer Touch Point Results, Operating Guidance, and Recommendations for Rescuer Safety – Final Report

---

We conducted time-series analysis for each test condition, correlating specific maximum current (or voltage) events to a given test condition. For each test condition, we analyzed data recordings in back-to-back 5-second long periods, synchronizing results with the GPS positional data using Microsoft® Office Excel® and MATLAB® functions. For each 5-second period, we determined the peak voltage across each calibration resistor by locating the absolute value of the single sample with the highest magnitude within that period. In general, this single peak occurred at the “top” of the pulsed waveform, and occurred with both positive and negative polarity, depending on the location of the test vessel with respect to the pulser electrodes. In addition, we computed the root mean square (rms) amplitude of each 5-second period to establish the average current measured through each resistor during the period. We computed electrical currents using Ohm’s Law by dividing the measured voltage across each calibration resistor and dividing by the known resistance (500 ohms).

The measurement environment was very noisy from an electrical perspective. Several times during the experiment period, we intermittently observed external sources of electrical or radio frequency (RF) energy in the recorded data. Because the pulsed energy from the barriers provided a highly recognizable waveform, we edited suspected interference patterns from the data and did not process them for peak or rms data results. For various test conditions identified in Table 4, this report provides tabularized values and graphical charts that show the data results, and indicate the measured electrical current to human threshold sensitivity with a colorized scale.

Published human sensitivity data for electrical current were not available for the frequencies produced by the barrier pulsers (5, 15, and 30 Hz). Therefore, we analyzed human sensitivity to 60 Hz alternating current (AC) current following the human responses as described in the NEDU report (Reference 4) to approximate the expected response. In all cases, the peak currents are shown, which provides a more conservative (i.e., “worst-case”) estimate compared to the average or rms current for the same test condition.

## 3.2 Observations

### 3.2.1 Test Condition 1: Free-field Current

The objective of this test was to measure the expected worst-case electrical current flowing through the chest area of a PIW exposed to electric fields immersed in the CSSC. A towed sensor array was used such that it could be towed well behind the tow vessel to ensure that a true free-field condition was sensed; previous tests used an apparatus mounted to the side of a test vessel, which could have affected the sensed readings. The towed sensor array provided measurement points along two orthogonal, horizontal directions (along the canal, parallel the test vessel track, and side-to-side in the canal, perpendicular to the test vessel track.), and one vertical direction. As expected, measured levels parallel to the canal varied substantially as the test vessel transited across each barrier. However, measured data in the orientation parallel to the canal flow direction did not vary significantly across the canal (center of the canal to the canal bank).

We observed significant electrical currents in this test condition, with barriers operating at both 2.0 and 2.3 volts/inch. Maximum currents measured occurred horizontally along the direction parallel to the canal axis, with peak levels of 330 milliamperes (mA) observed for Barrier IIB operating at 2.3 volts/inch (see Table 5). Using 72” spacing, this current was equivalent to the nominal barrier setting of 2.3 volts/inch. Figure 15 shows the peak free-field electrical current between horizontal electrodes, 72” apart, oriented parallel to vessel track. Maximum levels from Barrier IIA in this same operating condition (2.3 volts/inch)



## CSSC Fish Barrier Simulated Rescuer Touch Point Results, Operating Guidance, and Recommendations for Rescuer Safety – Final Report

resulted in a worst-case peak current of 310 mA, equivalent to approximately 2.2 volts/inch. Measured levels for Barrier IIB were consistently higher than the same condition for Barrier IIA, although worst-case levels generally agreed to within approximately 8 percent. Results are scaled proportionally with barrier operational voltage in this orientation.

Table 5. Test Condition 1, free field test results.

Test Point/ Channel ID*	Test Point Description	Worst-Case Peak Current (mA)	
		Barrier IIA	Barrier IIB
A <sub>0</sub>	Channel 1, free-field current, 72" spacing, side-to-side orientation, perpendicular to canal flow, 2.3 volts/inch	48	54
A <sub>0</sub>	Channel 1, free-field current, 72" spacing, side-to-side orientation, perpendicular to canal flow, 2.0 volts/inch	47	50
A <sub>1</sub>	Channel 2, free-field current, 72" spacing, fore-aft orientation, parallel to canal flow, 2.3 volts/inch	310	330
A <sub>1</sub>	Channel 2, free-field current, 72" spacing, fore-aft orientation, parallel to canal flow, 2.0 volts/inch	275	290
A <sub>2</sub>	Channel 3, free-field current, 48" spacing, vertical orientation, 2.3 volts/inch	36	38
A <sub>2</sub>	Channel 3, free-field current, 48" spacing, vertical orientation, 2.0 volts/inch	26	30
A <sub>3</sub>	Channel 4, terminated into 500 ohms, reference noise, cable on deck	0.4 <sup>1</sup>	

\*identification

<sup>1</sup>rms current noise, not peak value. Channel used to assess system noise floor.

Worst-case current in the side-to-side direction (72" spacing, oriented perpendicular to canal) was about one-sixth the strength of along-track measurements (see Table 5) at both 2.3 and 2.0 volts/inch operating conditions. Measured worst-case current at the 48" vertical sensor spacing was 38 mA on Barrier IIB at the 2.3 volts/inch operating condition. At 2.0 volts/inch (Figure 16), the 48" vertical level was 30 mA, which did not scale as predictably as the along-canal direction. Rms noise measured during this test using a dry-cable terminated into a 500 ohm resistor was 0.4 mA; thus measured values consistently exhibited good signal-to-noise ratios.



**CSSC Fish Barrier Simulated Rescuer Touch Point Results, Operating Guidance, and Recommendations for Rescuer Safety – Final Report**

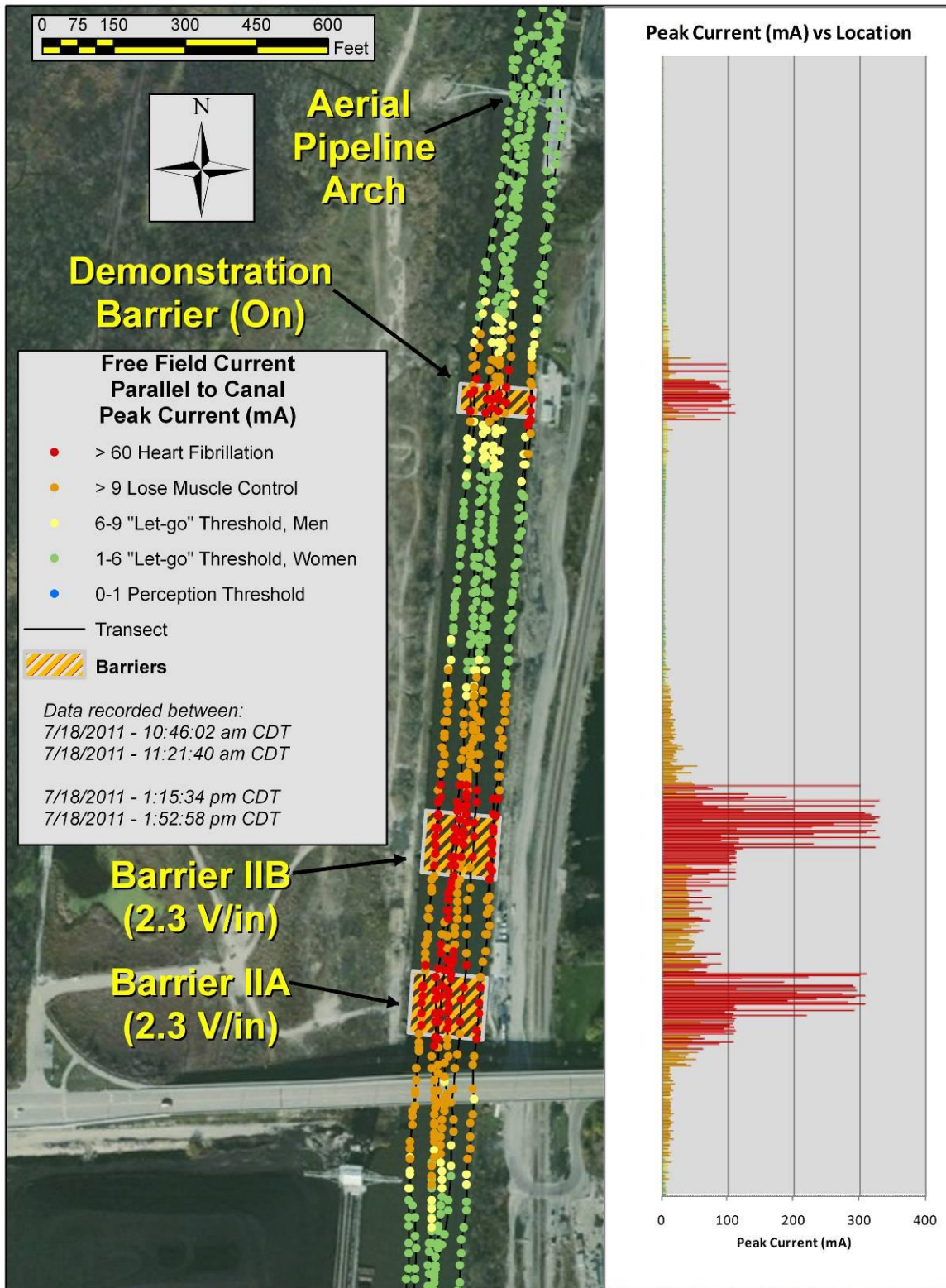

Figure 15. Peak free-field electrical current (mA) between horizontal electrodes, 72” apart, oriented parallel to vessel track, 2.3 volts/inch.





# CSSC Fish Barrier Simulated Rescuer Touch Point Results, Operating Guidance, and Recommendations for Rescuer Safety – Final Report

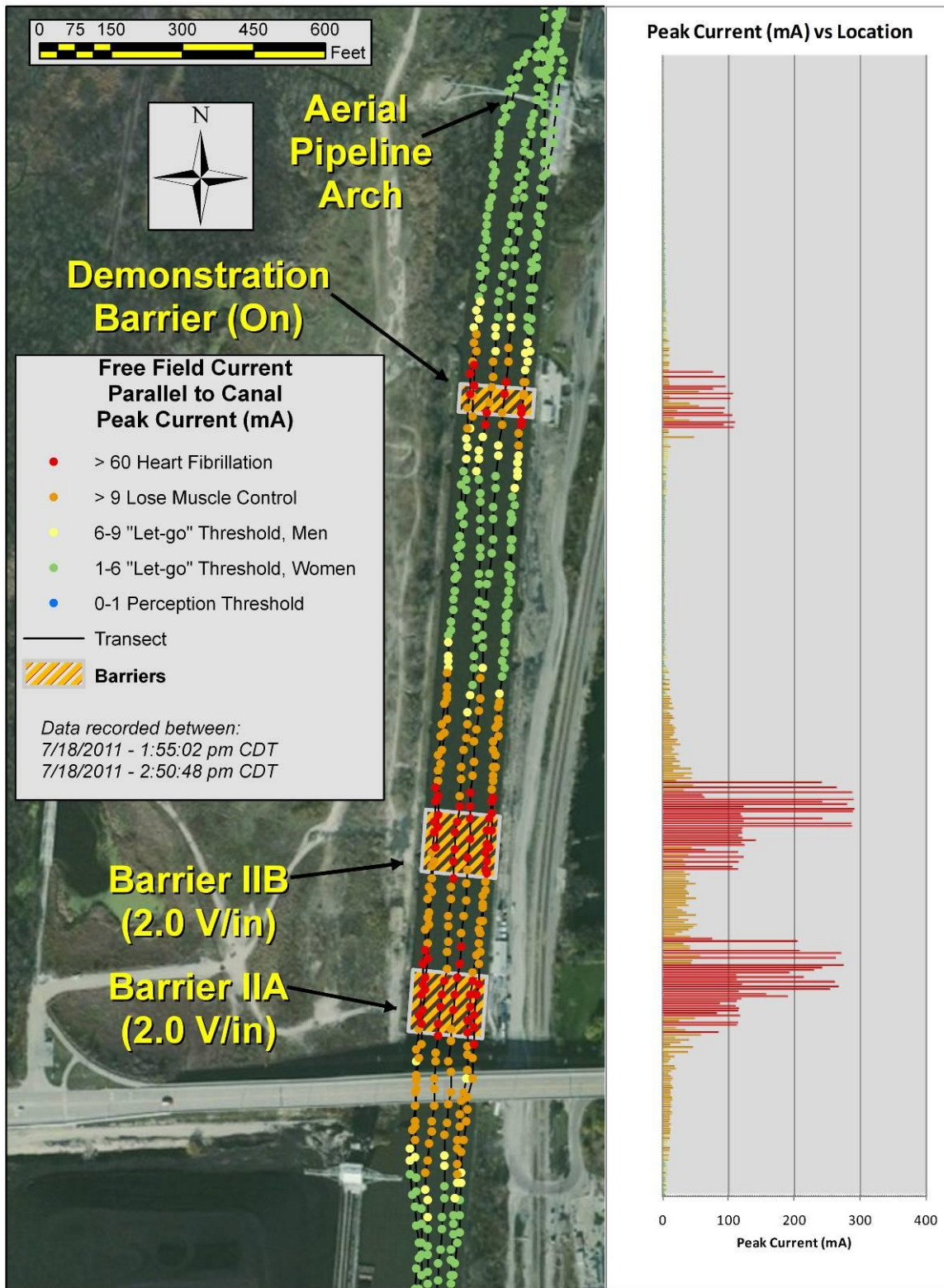

Figure 16. Peak free-field electrical current (mA) between horizontal electrodes, 72” apart, oriented parallel to vessel track, 2.0 volts/inch.





# CSSC Fish Barrier Simulated Rescuer Touch Point Results, Operating Guidance, and Recommendations for Rescuer Safety – Final Report

## 3.2.2 Test Condition 2: Rescue Vessel Recovery Touch-point Current

The objective of this test series was to measure the electrical current flowing through the touch-point of a rescuer on aluminum and fiberglass vessels, in contact with a floating PIW victim, with an electrical current path through the rescuer’s body, returning to the canal water through the hull of the test vessel.

### 3.2.2.1 Aluminum Hull Test Vessel

As in Test Condition 1, we observed significant electrical currents in this test condition. The maximum current measured in this condition was 191 mA (see Table 6). Figure 17 shows the peak current flowing from a PIW in direct contact with the metallic hull of a rescue vessel with Barriers IIA and IIB operating at 2.3 volts/inch. This test condition demonstrated that significant electrical currents can flow via a “victim” in the water through a “rescuer” electrically connected with a well-grounded metallic object (a vessel). Furthermore, this test showed that the PIW should not directly touch the hand of a rescuer on an aluminum vessel, or the vessel hull. For this test, we executed several transects through the center of the canal and along both sides. Figure 18 shows results with an aluminum hull when operating the barriers at 2.0 volts/inch.

Table 6. Test Condition 2, vessel touch-point results.

Test Point/ Channel ID	Test Point Description	Worst-Case Peak Current (mA)	
		Barrier IIA	Barrier IIB
A <sub>0</sub>	Channel 1, vessel touch-point current, aluminum hull, nominal 12” electrode depth, 2.3 volts/inch	160	175
A <sub>0</sub>	Channel 1, vessel touch-point current, aluminum hull, nominal 12” electrode depth, 2.0 volts/inch	131	158
A <sub>0</sub>	Channel 1, vessel touch-point current, aluminum hull, nominal 39” electrode depth, 2.0 volts/inch	191	138
A <sub>0</sub>	Channel 1, vessel touch-point current, fiberglass hull, 12” electrode depth, 2.3 volts/inch	<2	<2
A <sub>0</sub>	Channel 1, vessel touch-point current, fiberglass hull, 12” electrode depth, 2.0 volts/inch	<2	<2
A <sub>0</sub>	Channel 1, vessel touch-point current, fiberglass hull to metal motor mount, 12” electrode depth, 2.0 volts/inch	131	159
A <sub>3</sub>	Channel 4, terminated into 500 ohms, reference noise, cable on deck	<2 mA peak <.4 mA rms	

Worst-case peak currents measured with the aluminum test vessel in July 2011 were 191 mA, with typical peak levels ranging from 131 mA to 175 mA for various barrier settings and electrode configurations (see Table 6). Measured current values from November 2010 were substantially higher (nearly 1 ampere (amp)) than measured in July 2011, most likely due to the test vessel configuration. In November 2010, an aluminum-hulled test vessel with a painted hull was used for the test, and the actual electrical current path was not surveyed which was well beyond the scope of the test. Therefore, the separation distance from the test electrode and the hull was not known, but could have been several times further apart than with the new, unpainted hulled vessel. Regardless, in both cases with the aluminum-hulled test vessel, the measured electrical currents were well above the onset level for fibrillation.



# CSSC Fish Barrier Simulated Rescuer Touch Point Results, Operating Guidance, and Recommendations for Rescuer Safety – Final Report

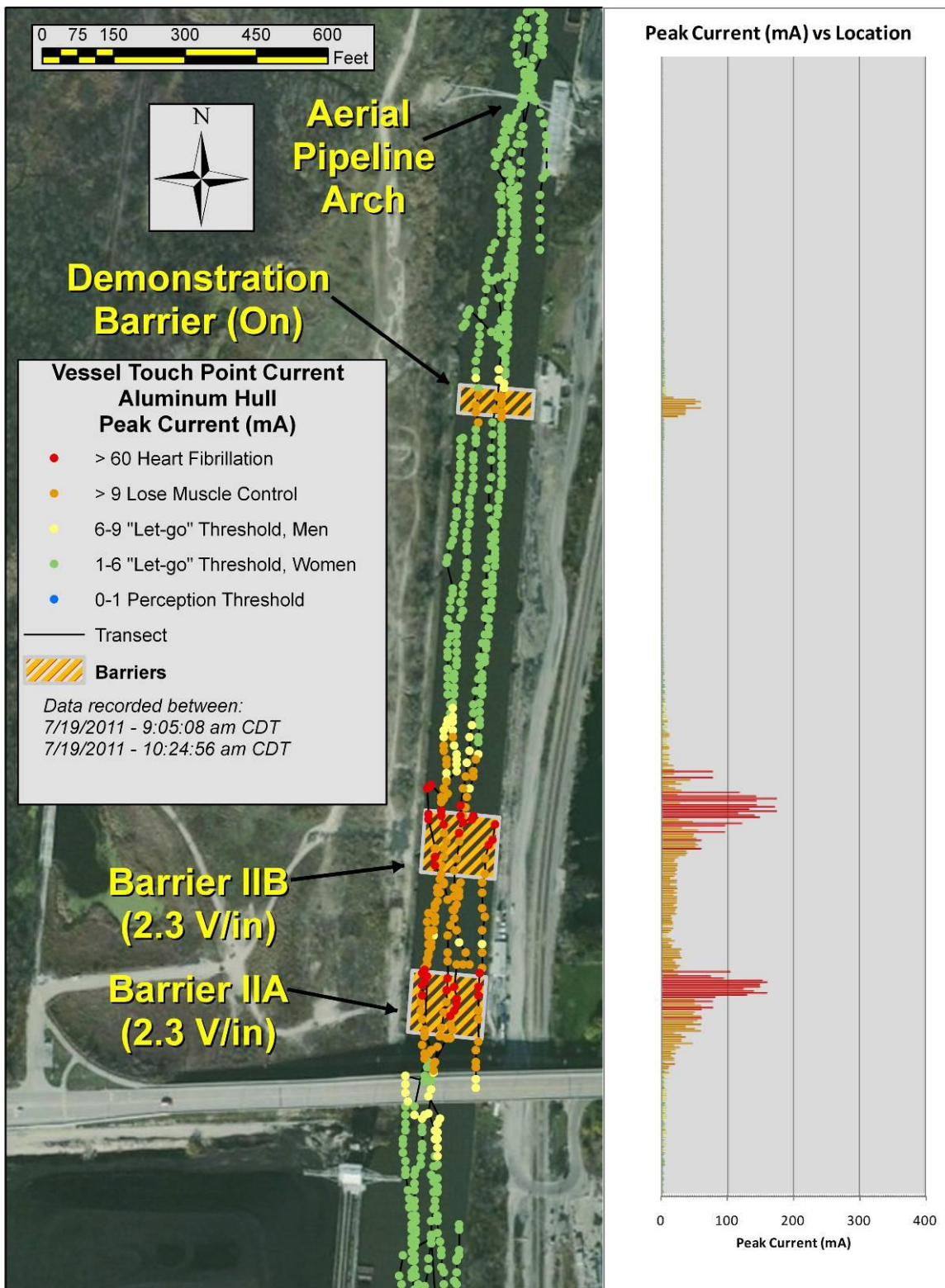

Figure 17. Peak rescue vessel electrical current (mA), aluminum hull, 2.3 volts/inch.



# CSSC Fish Barrier Simulated Rescuer Touch Point Results, Operating Guidance, and Recommendations for Rescuer Safety – Final Report

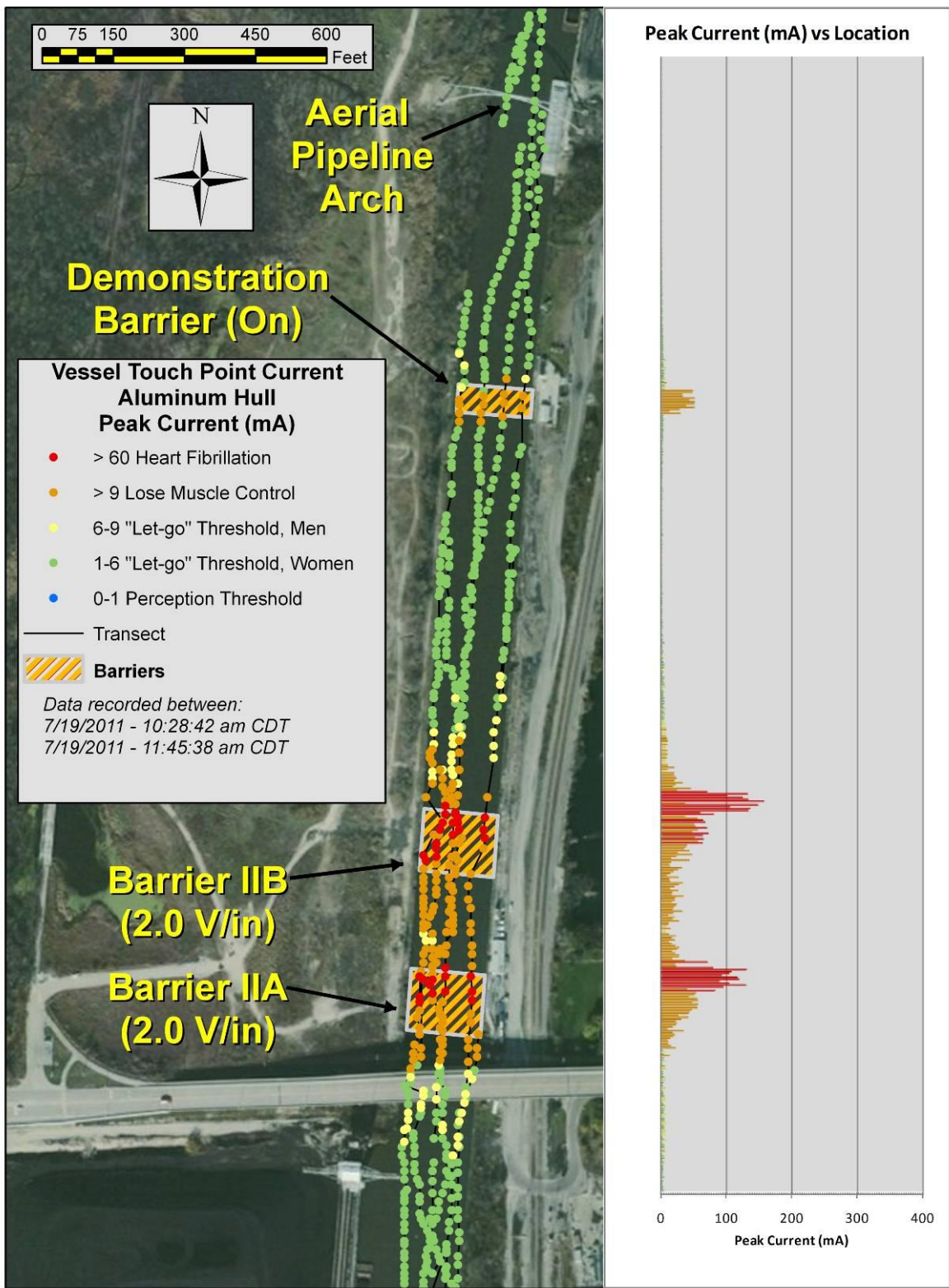

Figure 18. Peak rescue vessel electrical current (mA), aluminum hull, 2.0 volts/inch.





## CSSC Fish Barrier Simulated Rescuer Touch Point Results, Operating Guidance, and Recommendations for Rescuer Safety – Final Report

---

### 3.2.2.2 *Fiberglass Hull Test Vessel*

Unlike test results with the aluminum-hulled vessel, electrical currents with a simulated PIW via the fiberglass hull produced very low levels, even below the threshold for measurement with the instrumentation setup (see Figure 19). With one electrode in the water and the other attached to the hull, electrical currents due to the barrier operation were not discernible over the system noise floor (less than 2 mA peak, .4 mA rms, see Table 6). The level of human perception of shock is approximately 1 mA or less, indicating that a fiberglass hull can provide excellent isolation from shock. As expected, essentially identical results were observed (Figure 20) with Barriers IIA/B operating at 2.0 volts/inch. **WARNING: These observations were made with a single electrode in the water. It may be possible for a rescuer to receive electrical shock by placing two bare hands into the water over the side of a fiberglass vessel, creating an electrical current path from one hand to the other via the chest area. In this scenario, the electrical insulating properties of the fiberglass hull would not protect the rescuer.**

A separate test was conducted with the fiberglass-hulled test vessel to assess the risk of touch-point currents with a rescuer in electrical contact with any metallic section of the hull immersed in the canal. For this test we connected the ground electrode to the outboard motor mount located on the transom. The mount was aluminum, most of which was submerged for the test. Worst-case measured currents in this configuration were 131 mA and 159 mA from Barriers IIA and IIB, respectively, operating 2.0 volts/inch (Figure 21). This condition was not evaluated at 2.3 volts/inch. This result shows that even in a fiberglass vessel, rescuers need to be attentive to avoid creating a low resistance electrical path through their bodies, either by touching the motor or motor mounts, railings, ladders, or other components that may have electrical contact with the canal water. Although not evaluated, there is also the potential for bilge water in a fiberglass rescue vessel to become a conductive path, if the rescuer were in contact with the water. This condition should be avoided.

### 3.2.3 Test Condition 3: Shore Recovery Touch-point Current

The objective of this test was to measure the maximum current flow from a floating PIW to a grounded rescuer on the canal bank, with a current path from the PIW to the rescuer, then returning to the barrier via a conductive path through the ground. We implemented this test condition with an in-water electrode to simulate a PIW, and an aluminum plate and grounding strap fixture to simulate a rescuer on the bank making contact to the PIW via 500 ohms series resistor. A non-conductive fiberglass fishing rod held the PIW electrode. All locations were measured with a grounded electrode. However, in several locations two different grounding techniques were used to determine worst-case currents. The first with the standard grounded electrode condition, and the second with the electrode in direct contact with objects of opportunity, such as metallic fence posts, signs, or other convenient object that could potentially be used as an anchor point during a rescue.

We employed utmost caution during this test phase. The test team member holding the fishing rod near the canal bank was wearing protective equipment (including 600 V lineman's gloves) while being restrained by a non-conductive personnel tether. Other test team members served as safety observers, one with a radio, and another with a throwable device on a non-conductive line. The non-conductive rescue hook was also immediately available.



# CSSC Fish Barrier Simulated Rescuer Touch Point Results, Operating Guidance, and Recommendations for Rescuer Safety – Final Report

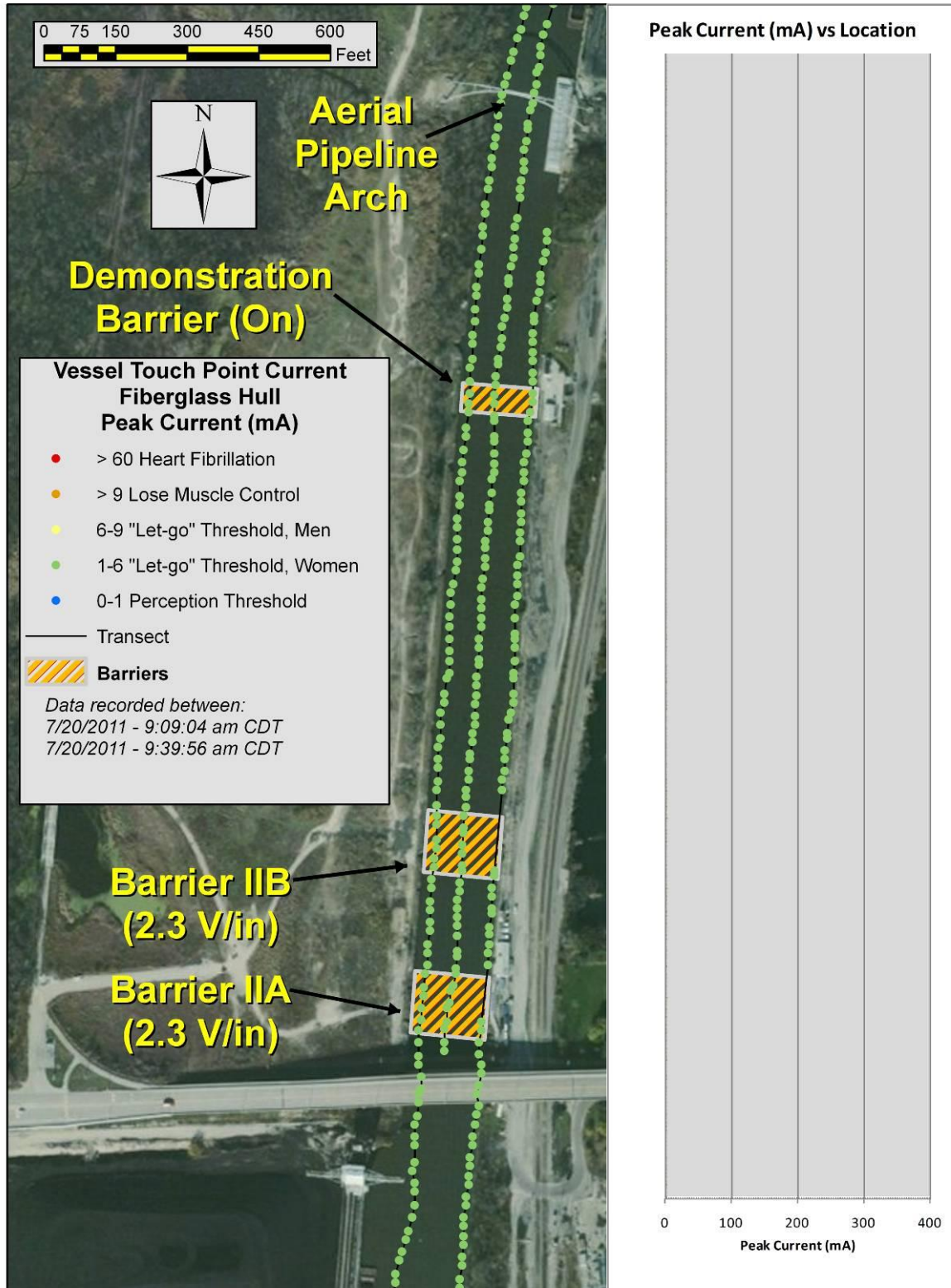

Figure 19. Peak rescue vessel electrical current (mA), fiberglass hull, 2.3 volts/inch.



# CSSC Fish Barrier Simulated Rescuer Touch Point Results, Operating Guidance, and Recommendations for Rescuer Safety – Final Report



Figure 20. Peak rescue vessel electrical current (mA), fiberglass hull, 2.0 volts/inch.





# CSSC Fish Barrier Simulated Rescuer Touch Point Results, Operating Guidance, and Recommendations for Rescuer Safety – Final Report

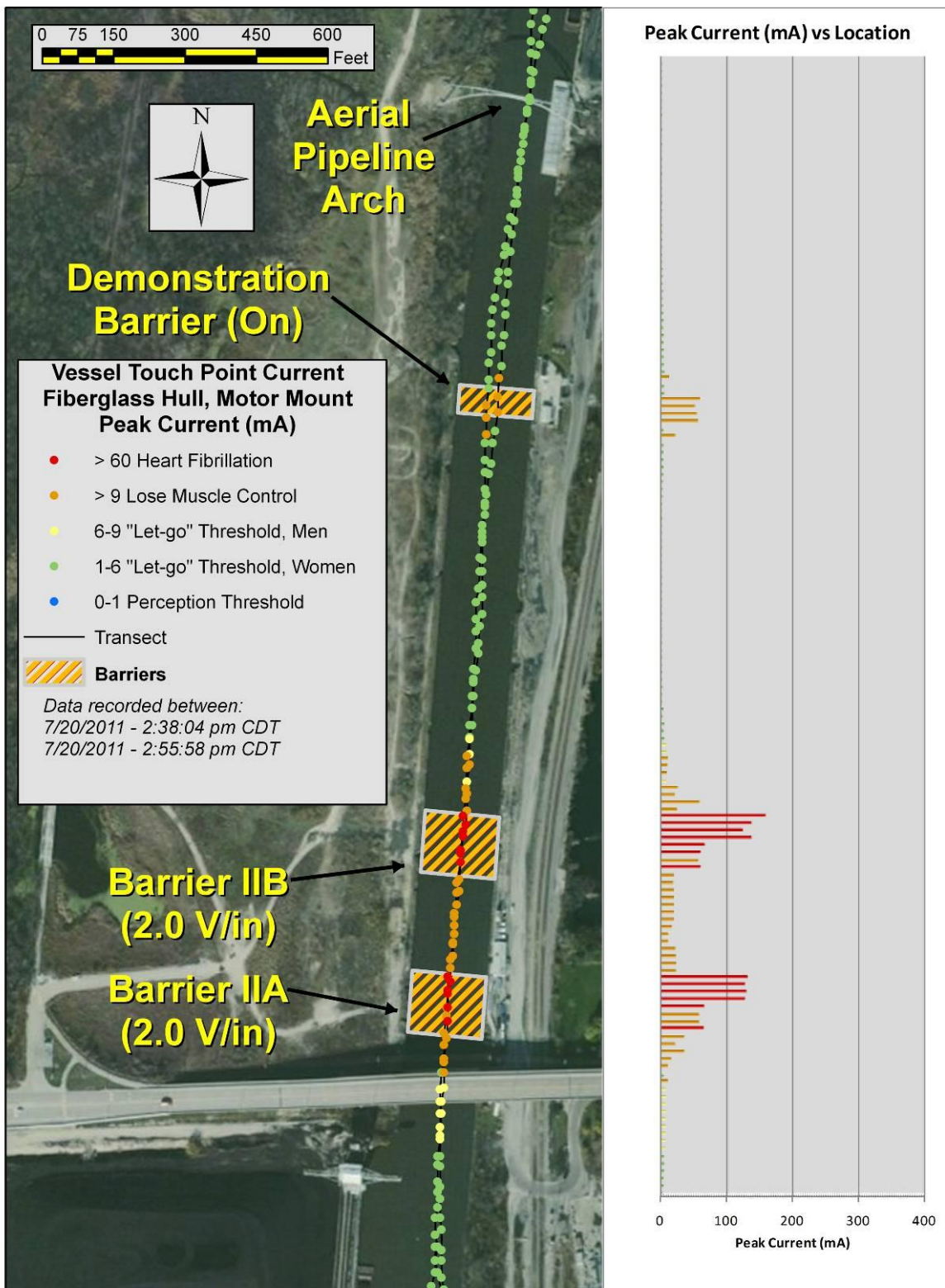

Figure 21. Peak rescue vessel electrical current (mA), fiberglass hull, metal motor mount, 2.0 volts/inch.



## CSSC Fish Barrier Simulated Rescuer Touch Point Results, Operating Guidance, and Recommendations for Rescuer Safety – Final Report

---

Temporary survey flags were placed along the security fence along the west bank of the canal to identify test locations. A total of 30 locations were measured, from under the Romeo Road bridge (south of Barrier IIA) to just north of the demonstration barrier (where access became impossible). Thirteen locations were measured under two grounding conditions described above. Two passes along the canal were made, the first with all three barriers operating (demonstration barrier and Barriers IIA and IIB). Barriers IIA and IIB were operating at 2.3 volts/inch on the first pass. We were also able to obtain measurements at some locations using metallic grounds of opportunity to compare differences between earth and metallic grounding conditions. Figure 22 shows results for earth grounded positions, and Figure 23 shows results for metallic ground positions. Table C-1 in Appendix C shows the positions measured and worst-case peak current measured at each location under this test condition.

A second pass along the canal was made with just the demonstration barrier and Barrier IIB operating at 2.3 volts/inch. Results for earth ground conditions are shown in Figure 24, and Figure 25 shows results for metallic ground conditions at locations of opportunity. Positions measured and worst-case peak current for each position for this test condition is provided in

Table C-2. In general, measured peak-currents at positions south of location 1X (41.641633, -88.060617) were substantially lower when Barrier IIA was not operating compared to when all barriers were operating. However, even with Barrier IIA off, measured touch-point currents south of location 1X were sufficient to cause fibrillation and loss of muscle control. This result demonstrates that areas south of the primary barriers are not generally suitable for a shore-point rescue. Measurements acquired north of location 1X were dominated by operation of Barrier IIB and the demonstration barrier, thus measured results in these locations for the second pass were similar to those measured during the first pass. Some differences in measured values were noted from the first to second passes at the same positions, due to the imprecise manner in which the ground electrodes were established at each position.

Results for this test condition were strongly dependent on the resistance between the ground electrode and the earth, and the location of each test. Tests using a metallic object of opportunity (e.g., sign post or grounded fence post) resulted in the highest levels measured (316 mA on an embedded steel fence post), as might be expected, thus creating a higher risk of shock hazard than simple earth grounds (e.g., earth, rocks, or vegetation). However, grounded positions without an embedded metallic object at some locations were nonetheless sufficient to cause loss of muscle control, since worst-case peak current exceeded 20 mA. Maximum levels of 49 mA were observed for earth ground tests using the aluminum plate electrode apparatus. Measurement noise levels were approximately 1.5 mA (peak) throughout this test condition. In a general sense, highest levels were also measured adjacent to the operating barriers, although as previously described, areas south of Barrier IIB exhibited high levels even when Barrier IIA was turned off.

Touch-point current with the canal bank showed that the magnitude of electrical current hazard strongly related to the electrical resistance to the grounding point. We note that observed conditions during the July 2011 data collection period were relatively dry (mid-summer), and earth conductivity may change throughout the year due to amounts and recency of precipitation.





# CSSC Fish Barrier Simulated Rescuer Touch Point Results, Operating Guidance, and Recommendations for Rescuer Safety – Final Report



Figure 22. Results for shore touch-point current, “earth ground”, all barriers operating.



# CSSC Fish Barrier Simulated Rescuer Touch Point Results, Operating Guidance, and Recommendations for Rescuer Safety – Final Report

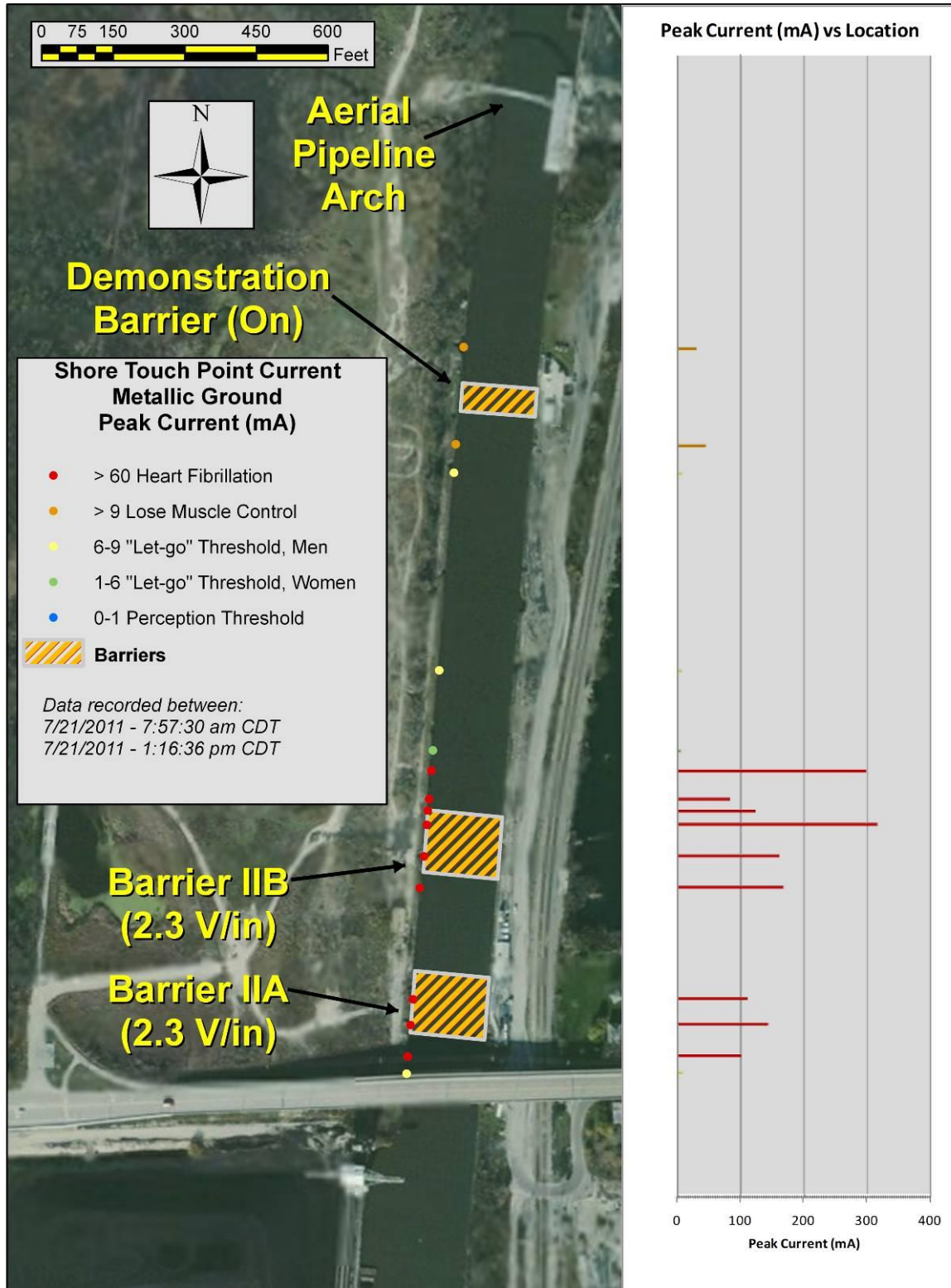

Figure 23. Results for shore touch-point current, “metallic ground”, all barriers operating.



# CSSC Fish Barrier Simulated Rescuer Touch Point Results, Operating Guidance, and Recommendations for Rescuer Safety – Final Report



Figure 24. Results for shore touch-point current, “earth ground”, Barrier IIA “off”.





# CSSC Fish Barrier Simulated Rescuer Touch Point Results, Operating Guidance, and Recommendations for Rescuer Safety – Final Report

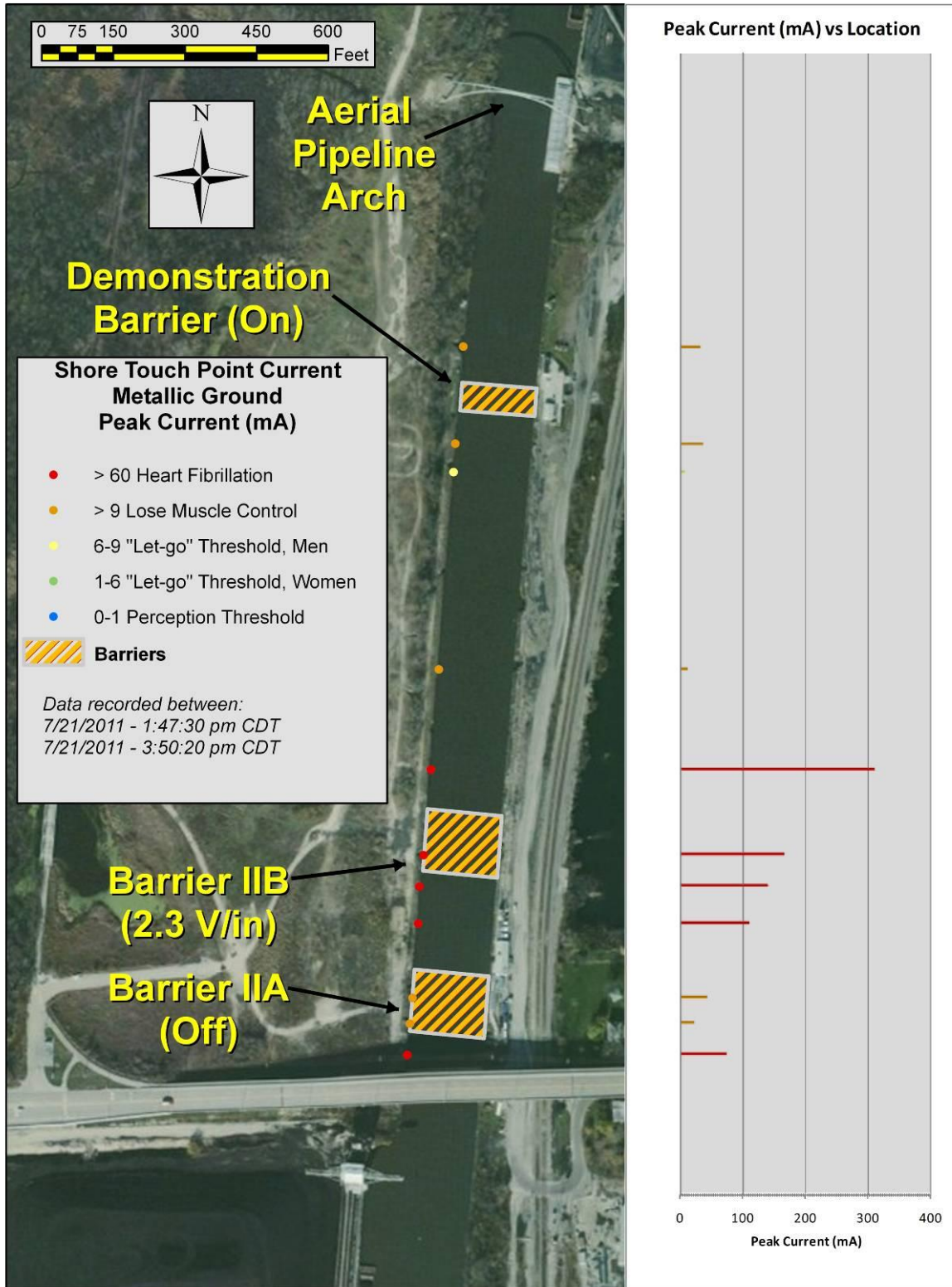

Figure 25. Results for shore touch-point current, “metallic ground”, Barrier IIA “off”.



# CSSC Fish Barrier Simulated Rescuer Touch Point Results, Operating Guidance, and Recommendations for Rescuer Safety – Final Report

## 3.2.4 Test Condition 6: Rescue Apparatus

The objective of this test was to measure the maximum current flow from a floating PIW to a grounded rescuer in an aluminum or fiberglass test vessel using a non-conductive rescue apparatus. Possible electrical circuit paths were evaluated for each hull type using a polypropylene soft line and a non-conductive rescue hook as a means to tow a PIW away from danger. For this test condition, the simulated rescuer was grounded to the test vessel hull. We modeled the PIW victim by affixing an input electrode to simulate a low-resistance body in the water to the recovery line/pole, and then to a life-ring to keep the apparatus near the surface. We conducted transects for various barrier operating conditions (2.0 and 2.3 volts/inch), per Table 4.

Measured results were the same for all conditions tested. Tests with the polypropylene line and non-conductive rescue hook for both aluminum and fiberglass-hulled vessels did not produce observable results above the background noise of the recording system (system noise was less than 2 mA peak), and would not pose a hazard for rescuers using these tools (see Table 7). This report does not include a figure depicting the background noise level.

Table 7. Test Condition 6, rescue apparatus results.

Test Point/ Channel ID	Test Point Description	Peak Current (mA)	Comments
A <sub>0</sub>	Touch-point current, polypropylene line, aluminum hull, 2.3 volts/inch	<2 <sup>1</sup>	Pulses not seen above background noise
A <sub>0</sub>	Touch-point current, non-conductive rescue hook, aluminum hull, 2.3 volts/inch	<2 <sup>1</sup>	Pulses not seen above background noise
A <sub>0</sub>	Touch-point current, non-conductive rescue hook, aluminum hull, 2.0 volts/inch	<2 <sup>1</sup>	Pulses not seen above background noise
A <sub>0</sub>	Touch-point current, polypropylene line, fiberglass hull, 2.3 volts/inch	<2 <sup>1</sup>	Pulses not seen above background noise
A <sub>0</sub>	Touch-point current, polypropylene line, fiberglass hull, 2.0 volts/inch	<2 <sup>1</sup>	Pulses not seen above background noise
A <sub>0</sub>	Touch-point current, non-conductive rescue hook, aluminum hull, 2.3 volts/inch	<2 <sup>1</sup>	Pulses not seen above background noise
A <sub>0</sub>	Touch-point current, non-conductive rescue hook, aluminum hull, 2.0 volts/inch	<2 <sup>1</sup>	Pulses not seen above background noise

<sup>1</sup>Peak level of background current noise. No electrical pulses measured. Rms noise level in this condition was <0.3 mA.

## 4 ELECTRIC CURRENTS AND THE HUMAN BODY

Electric currents can be described and their effects are explained well in the physical world. Electric currents traveling through wires, resistors, and capacitors can be scientifically explained mathematically and demonstrated using modeling and simulation. Therefore, the effects of an electric current, and duty cycle, are easily tested and demonstrated using specific models allowing only the selected parameter to be changed over a range. This specific type model is not available when we look for specific answers concerning the effects of an electric current upon a human.

## CSSC Fish Barrier Simulated Rescuer Touch Point Results, Operating Guidance, and Recommendations for Rescuer Safety – Final Report

---

The NEDU study (Reference 4) makes this statement and it is worthy of repeating:

The physiological effects of an electric current passing through a given individual's body depend on several variables: the duration, magnitude, and frequency of the current; the weight of the person; and the specific path the current takes through the body. The most dangerous consequence of such an exposure is the heart condition known as ventricular fibrillation, in which the blood immediately ceases to circulate.

The NEDU study also makes other important points concerning the effects of current on the human body. Please note that these effects are for alternating currents. It is also stated in the NEDU study that it is possible for the human body to tolerate "single shock" direct currents (DC) that are five times higher for a given physiological effect. The duty cycle of the barrier current may cause the effect to resemble something in between a direct current and an alternating current. **Note: for the purposes of this report, we assume a "worst-case" condition and are considering the effect of pulsed DC to be the same as the effects of AC.**

The NEDU study also states the following physiological effects to the human body with various levels of shocks due to exposure of 50 to 60 Hz AC rms signals.

- "In order of increasing current, the most common physiological effects of electricity on the body are threshold of perception, muscular contraction, difficulty breathing, cessation of breathing unconsciousness, heart fibrillation, respiratory nerve blockage, and burning. The levels at which some of these effects occur are given below for 50-60 Hz AC:
  - A 1 mA rms current is generally recognized as the threshold of perception, the level at which a person is just able to detect a slight tingling sensation in hands or fingertips.
  - Currents of 1-6 mA rms (often called "let-go" currents), while unpleasant to sustain, generally do not prevent a person holding a charged object from being able to control his (or her) muscles and release it. For the 0.5 percentile population, 6 mA rms for women and 9 mA rms for men are the measured let-go threshold values.
  - Currents of 9-25 mA rms may be painful and may make it difficult or impossible for the hand to release energized objects it has grasped. For still higher currents, muscular contractions could make breathing difficult. The effects of 9-25 mA rms currents usually are not permanent and disappear when these currents are removed, unless contraction is very severe and breathing is stopped for minutes rather than seconds.
  - Currents of 60-100 mA rms can cause ventricular fibrillation, heart stoppage or cessation of respiration – and result in permanent injury or death."

Charts shown within this report are colorized to show human effects commensurate with those noted above from the NEDU study. It should be noted that these thresholds are stated for rms shocks, not peak values.





## CSSC Fish Barrier Simulated Rescuer Touch Point Results, Operating Guidance, and Recommendations for Rescuer Safety – Final Report

---

The human body can and has been described in general terms as a huge resistor of about 500 ohms. The physical mathematical equations applied, and therefore answers, are only as valid as the general terms and the general model used. Why is this? First, we do not experiment with electricity on human beings – unless there is a potential benefit. We are, therefore, confined to the science of making scientific conclusions by extrapolation. The physiology of the human body causes each of us to react to various stimuli differently along a normal (Gaussian) distribution of reactions.

The point is simple. The interaction of the human with electricity is not an exact science. We cannot expect exact parameters; therefore, we must speak to electricity and the human interface with several standard deviations of safety because we are not sure who will withstand 100 mA and who will succumb to 1 mA of exposure delivered at the right time, and right conditions.

### 4.1.1 An Illustration

Three golfers are in a close group. Lightning makes an indirect strike (no direct hit) in their vicinity. Two of the golfers describe tingling (1-10 mA), the other drops dead. We can assume they each got about the same exposure. The “tingling sensation” felt by two of the golfers was caused by the same current that struck the third member at a critical period in his cardiac cycle and put him into ventricular fibrillation and arrest. This critical period of the cardiac cycle is during the electrical period called the “T” wave. This report must be concerned with the effects of small electric currents on the human being, so the authors are perhaps overstating for safety reasons that the same small “tingling” current delivered at a critical time could send a human into ventricular fibrillation and death.

### 4.1.2 Cardiac Physiology

The heart is made up of a special type of muscle. If left unattended, the muscle spindle will twitch (beat) at some regular rhythm. The group of muscles making up the atria and ventricles (upper and lower chambers of the heart) can be synchronized and perform work by an electrical stimulus passing through a set of fast conduction tissue (wires). If the heart is functioning normally, the upper chamber (atrium) contracts, sending blood into the ventricles and simultaneously sending an electrical stimulus through a node to the ventricles which causes them to contract at just the right time to send blood into the body and lungs. When this electrical activity is recorded, it is called an electrocardiogram (EKG) and the waveform generated has several parts, with each representing something electrically happening in the muscle cell: contraction, relaxation, recharging, and a small moment of pre-excitement as it gets ready to receive the electrical signal to contract. The parts of this pattern are called the p, q, r, s, and t waves of the EKG. These waves are the equivalent of the cell cycles of contraction, relaxation, and recovery to readiness of the cardiac muscle cells. The “T” wave represents a pre-excitement moment and the muscle is very susceptible to electric currents at that precise moment. If a very small current is applied at that moment, the cell shudders and causes other cells and muscles to shudder; this is called fibrillation. Small currents passed through the heart on the “T” wave can cause fibrillation and death. During fibrillation, each muscle cell is firing in an uncoordinated manner; therefore, no blood is being pumped from the heart. A very small current can cause fibrillation if it is conducted over a wire that is implanted in the heart such as a pacemaker wire and the spike hits on the “T” wave of the cardiac cycle.

Active defibrillation is necessary to convert fibrillation back to a physiological rhythm. Defibrillation generally takes larger voltages and currents. Defibrillation is an act of passing a strong-enough current across the heart that arrests all the cells, allowing the pacer cells to regain their supremacy and cause a normal rhythm to resume.



## CSSC Fish Barrier Simulated Rescuer Touch Point Results, Operating Guidance, and Recommendations for Rescuer Safety – Final Report

---

**WARNING:** The measurements obtained through this work within the barrier portion of the CSSC show currents and duty cycles that can induce cardiac fibrillation in a human being. This is especially true in the directly above or adjacent to the barriers. However, the smaller currents recorded throughout the barrier zone may cause fibrillation if the human being has an electrical wire such as a pacing cable implanted inside his or her heart. One mA may be sufficient to cause fibrillation if the current flows to the myocardium and arrives just at the time of the “T” wave in the cardiac cycle.

The common literature described in the NEDU study, and repeated for emphasis earlier in this report, describes tingling at <1 mA, 1-9 mA as “let-go” currents, 9-25 mA as painful and muscular spasm, and 60-100 mA for ventricular fibrillation/cardiac arrest and death, which are most likely expressed at the mid portion of a Gaussian distribution of human beings. For safety and rescue planning, we must use the least possible danger level and circumstance and provide protection in the way of warnings and education for absolute protection for rescuers.

## 5 DISCUSSION OF RESULTS

Data analysis showed that significant electrical currents were encountered within the electrified area of the CSSC and, without significant precautions, could endanger rescue personnel. Voltage levels in the barrier zone were sufficient, both in strength and level of electrical current capacity, to impart potentially harmful electrical currents to victims and rescuers alike based on expected human responses per the NEDU study (Reference 4). This condition is especially true while operating close to the barrier electrodes. Electrical-shock hazards decrease with distance from the barriers, as shown in the figures in this report.

Testing showed that use of non-conductive materials (e.g., polypropylene rope or non-conductive rescue hook) to retain or move a potential PIW resulted in very low (i.e., not measurable above the noise floor) electrical current through a simulated rescuer even in the most electrically active section of the barrier zone. This result was the same for aluminum and fiberglass-hulled vessels.

Electrical currents through a simulated rescuer when in contact with a simulated PIW were highest when in direct contact with the metallic hull of the aluminum rescue vessel, or when in contact with an immersed metallic component of a fiberglass vessel (e.g., the metal motor mount). The wetted metal hull or other metallic component in contact with electrified water provides a direct path for the electrical current, and successful rescue methods must incorporate electrical isolation of the rescuer and victim alike from the wetted metallic components via the use of non-conductive materials.

Even from a non-metallic hulled vessel, if one rescuer places two bare hands, (or two rescuers in contact with each other place one hand, each) in the electrified water, the span between the hands would create an electrical path that may result in an electrical shock to the rescuer(s). In this scenario, the electrical insulating properties of the fiberglass hull would not protect the rescuer(s).

Electrical currents associated with a PIW in contact with the canal bank or a grounded simulated rescuer on the canal bank were measured from south of Barrier IIA to north of the demonstration barrier. Maximum electrical currents were shown to occur when a metallic grounding point was established, either via sign post, fence post, or other embedded metallic object. However, in some locations with a simple earth ground, electrical currents through a simulated rescuer could be high enough to cause fibrillation.



## 6 CONCLUSIONS

Data obtained during 18-21 July 2011 testing at the CSSC confirmed and amplified results from 17-19 November 2010 testing. Testing in 2011 confirmed that use of non-conductive materials can effectively isolate a potential rescuer from electric shock. In particular, use of polypropylene rope and a non-conductive rescue hook were shown to be very effective. In addition, we showed that a fiberglass hull can provide substantial electrical isolation for a potential rescuer. The following conclusions draw from November 2010 and July 2011 results.

1. A human floating through the electrified zone would be subjected to potentially lethal, through-the-body electric currents that approach 1 amp. This would occur in the vicinity of the strongest electrical fields near Barriers IIA and IIB.
2. Exposure of simulated human electrodes to conductive canal water revealed that simulated wet human skin would not hinder electrical current flow. In other words, the electrical resistance of the simulated human body did not offer any protection against the flow of electricity.
3. Simulated human skin from a PIW in direct contact with the rescue vessel metallic hull is more hazardous than having no contact at all with the rescue vessel. Rescue methods need to isolate the PIW from metallic objects.
4. Polypropylene rope and a non-conductive body rescue hook negligible amounts of current to a simulated rescuer on an aluminum or fiberglass vessel, and are potential rescue tools. Nylon braid, although not exhibiting a substantial amount of current, was not seen as a positive tool, due in part to the weight of the rope and its hydrodynamic behavior in water once soaked or submerged.
5. A fiberglass-hulled rescue vessel provides excellent isolation from shock hazard when in the barrier zone. However, it is possible to introduce a shock hazard by making contact with wetted metallic items onboard a fiberglass-hulled vessel, such as the motor, motor mount, swim ladder, or other portion of the vessel or hull that has direct contact with the canal water.
6. Touch-point current to the canal bank showed that the magnitude of electrical current hazard to a rescuer or PIW is strongly related to the electrical resistance to the grounding or contact point. Low resistance ground points such as metallic sign posts, fence posts, or other electrical equipment can cause substantial hazard with measured electrical current levels similar to those observed during in-the-water (free-field) testing. Earth-ground points offered higher resistance, although several locations next to the barriers are capable of delivering electrical currents sufficient to cause fibrillation. Conditions during the July 2011 data collection period were relatively dry (mid-summer), and earth conductivity may change throughout the year.
7. Some areas of the canal bank, even those between the demonstration barrier and Barrier IIB, offer less of a shock risk compared to downstream locations near Barrier IIB, and even south of Barrier IIA under the Romeo Road bridge. This suggests that potential shore-side rescue may be viable, if such rescue could occur before the victim transits the “hottest” electrical zones. In such a scenario, the rescuer could use non-conductive apparatus to maneuver a PIW away from the most dangerous zones to minimize risk to both the victim and the rescuer.
8. In general, non-conductive or resistive materials, such as rubber, plastic and fiberglass, are effective in reducing the electrical current risk to a rescuer, so long as the rescuers understand the electrical current paths and take precautions to avoid becoming part of the electrical circuit. A rescuer could inadvertently create an electrical circuit through their own body, by putting two bare hands in the area of electrified water, even while remaining on a fiberglass vessel.
9. The location of the actual electric fields is not *readily* apparent to those operating in the canal nor on the canal bank. Though the entrance and exit from the Safety Zone are marked (south of the



## CSSC Fish Barrier Simulated Rescuer Touch Point Results, Operating Guidance, and Recommendations for Rescuer Safety – Final Report

---

bridge and north of the aerial pipeline arch), there are no obvious flags, signs, paint, or other markers to indicate the presence or strength of the electric field. Rescuers or PIWs may find it beneficial, even between Barriers I and II, to have immediately available, *conspicuous*, visual indicators to know which direction to move to maximize safety, if conditions allow.

### 7 RECOMMENDATIONS

#### WARNING

**Under no circumstances should a rescuer enter or immerse any part of their body directly into the electrified waters in the CSSC. A rescuer should not make contact with any PIW (in the electrified area) unless the rescuer is electrically isolated from the PIW and the water. Any attempt at rescue in electrified water conditions is inherently hazardous. These recommendations serve to *mitigate* hazards to rescuers, but not eliminate them. Nothing in these recommendations should be construed that rescue in electrified water is anything but a hazardous undertaking.**

1. Do not, under any circumstances, permit a potential rescuer to enter the water or immerse any part of their body in the vicinity of the energized barriers. Use a non-conductive tether to prevent a rescuer from inadvertently entering the water, whether the rescuer is aboard a vessel or ashore.
2. When possible, use a non-metallic-hulled rescue vessel for attempting rescue of a PIW in the barrier zone. If rescuers must use a metallic hull, do not allow the metallic hull to make direct contact with the PIW.
3. If unable to assist the PIW from a vessel, use a polypropylene throw-rope and life ring to reach the PIW from shore.
4. Use dielectric materials, including poly line, non-conductive rescue hooks, and lineman's gloves, to provide a safer means of making contact with a PIW. Use them to keep all rescuer body parts from making contact with the water or with the PIW while the PIW is in the electrified zone. Protective equipment, including use of dielectric materials, should always be employed for rescues from the canal bank.
5. Use the dielectric materials to move the person out of the electrified zone as quickly as possible.
6. In conjunction with USACE and local first responders, develop special markings for the canal banks to delineate the areas within the barrier zone that allow a greater degree of rescuer safety than others.
7. Provide all potential responders a base level of electrical safety training that emphasizes circuit awareness, the risks associated with electricity and water, specific attention to variations rescue conditions in the CSSC electrified area, and deleterious effects of even extremely low currents on individuals with implanted electrical devices.
8. Develop "electrical rescue kits" that include ANSI 600V rated gloves and boots, ANSI 600V rated anti-shock mats, non-conductive, non-absorbing tethers, life rings with polypropylene throw-lines, and non-conductive rescue hooks for ready use, by either land-based or waterborne first-responders.
9. Use Figures 15 through 25 of this report, in conjunction with those from the August 2011 USACE report (Reference 5) as a visual aid to indicate those areas in the CSSC and along the west bank that may pose less of a hazard than others for rescuer activity.
10. Share the information in this report with local first responders and concerns that operate in the immediate vicinity of the safety zone, including those involved with maintenance of the Romeo Road Bridge.





## **8 REFERENCES**

1. “Dispersal Barrier Efficacy Study INTERIM IIIA – Fish Dispersal Deterrents, Illinois & Chicago Area Waterways Risk Reduction Study and Integrated Environmental Assessment,” USACE, Chicago District, April 2010.
2. “Asian Carp Brochure,” U.S. Fish and Wildlife Service, <http://www.fws.gov/midwest/Fisheries/library/broch-asiancarp.pdf>, April 2004.
3. “Demonstration Dispersal Barrier & Dispersal Barrier IIA Sparking Potential and Long Tow Testing to Determine Safety Considerations,” USACE ERDC/CERL, May 2008.
4. “Evaluation of Risk that Electric Fish Barriers Pose to Human Immersion in the Chicago Sanitary and Ship Canal,” Naval Experimental Diving Unit, NEDU TR 08-01, June 2008.
5. “2011 In-Water Testing of Aquatic Nuisance Species Dispersal Barriers IIA and IIB with Increased Voltage and Frequency Operating Parameters,” USACE ERDC/CERL, August 2011.
6. “Summary of Safety Studies Completed at Chicago Sanitary and Ship Canal Dispersal Barrier IIA”, USACE ERDC/CERL, December 2008.
7. “Rescue in Electrified Water; Experiment Test Plan,” SAIC Contract No. HSCG32-10-D-R00021, Task Order HSCG32-10-J-300002/Deliverable 1, 7 October 2010.
8. “Interim Report on CSSC Fish Barrier Simulated Rescuer Touch Point Results, Operating Guidance, and Recommendations for Rescuer Safety,” SAIC Contract No. HSCG32-10-D-R00021, Task Order HSCG32-10-J-300002/Deliverable 3, 3 February 2011.



**This page intentionally left blank.**



APPENDIX A MEASUREMENT TEST BOX SCHEMATIC

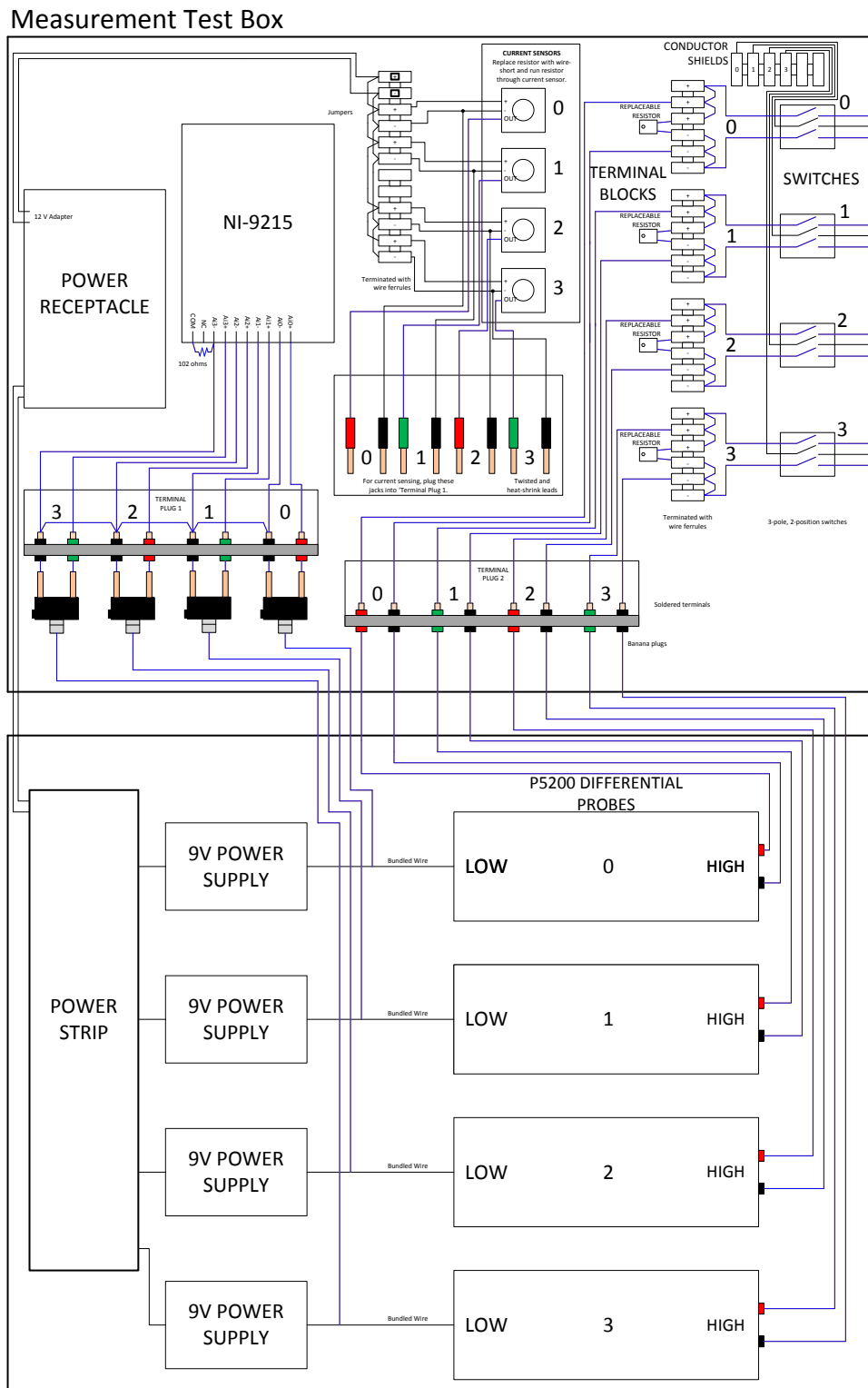

Figure A-1. Measurement test box schematic diagram.



**This page intentionally left blank.**





**CSSC Fish Barrier Simulated Rescuer Touch Point Results, Operating Guidance, and Recommendations for Rescuer Safety – Final Report**

**APPENDIX B BARRIER ELECTRICAL OPERATING PARAMETERS**

Nominal electrical operating parameters are summarized in Table B-1 and Table B-2 for periods of data collection. Over the duration of the surveys (18-21 July 2011), the USACE Fish Barrier facility logs did not indicate any significant variations from the data shown.

Table B-1. Barrier IIA nominal electrical parameters (18-21 July 2011).

Date (2011)	Time (local)	Voltage (Nominal)	Current (Nominal)	Freq. (Hz)	Pulse Length (ms)	Power (kW*)	In Water Voltage (V/in)	Parasitic (1/2/3)	Pulser On/Off (1/2/3)
7/18	10:35 - 11:25	1925	5849	30	2.5	853	2.3	on/off/on	on/off/on
	13:10 - 13:55	1925	5947	30	2.5	863	2.3	on/off/on	on/off/on
	13:55 - 14:55	1650	5127	15	6.5	809	2.0	on/off/on	on/off/on
7/19	09:04 - 10:30	1925	6044	30	2.5	892	2.3	on/off/on	on/off/on
	10:30 - 12:05	1650	5244	15	6.5	833	2.0	on/off/on	on/off/on
	13:05 - 15:20	1925	6113	30	2.5	895	2.3	on/off/on	on/off/on
7/20	09:05 - 11:05	1925	6201	30	2.5	883	2.3	on/off/on	on/off/on
	13:05 - 13:35	1925	5185	30	2.5	642	2.3	on/off/on	on/off/on
	13:35 - 14:58	1650	5332	15	6.5	847	2.0	on/off/on	on/off/on
7/21	07:35 - 11:00	1925	6015	30	2.5	872	2.3	on/off/on	on/off/on
	13:05 - 13:38	1925	6005	30	2.5	869	2.3	on/off/on	on/off/on
	13:38 - 15:55	0	0	0	0	0	0	off/off/off	off/off/off

\*kiloWatt

Table B-2. Barrier IIB nominal electrical parameters (18-21 July 2011).

Date (2011)	Time (local)	Voltage (Nominal )	Current (Nominal)	Freq. (Hz)	Pulse Length (ms)	Power (kW)	In Water Voltage (V/in)	Parasitic (1/2/3)	Pulser On/Off (1/2/3)
7/18	09:05 - 10:49	1600	5752	15	6.5	914	2.0	on/off/on	on/off/on
	10:49 - 11:24	1975	6767	30	2.5	1035	2.3	on/off/on	on/off/on
	13:53 - 14:52	1650	5761	15	6.5	913	2.0	on/off/on	on/off/on
7/19	09:05 - 10:25	1975	6806	30	2.5	1044	2.3	on/off/on	on/off/on
	10:25 - 13:00	1650	5888	15	6.5	981	2.0	on/off/on	on/off/on
	13:00 - 14:50	1975	6796	30	2.5	1085	2.3	on/off/on	on/off/on
	14:50 - 15:20	1650	6005	15	6.5	992	2.0	on/off/on	on/off/on
7/20	09:04 - 10:58	1950	6689	30	2.5	1007	2.3	on/off/on	on/off/on
	13:04 - 13:32	1950	6718	30	2.5	1012	2.3	on/off/on	on/off/on
	13:32 - 14:58	1650	5654	15	6.5	969	2.0	on/off/on	on/off/on
7/21	07:35 - 10:57	1950	6457	30	2.5	958	2.3	on/off/on	on/off/on
	13:03 - 15:55	1950	6640	30	2.5	998	2.3	on/off/on	on/off/on



**This page intentionally left blank.**



# CSSC Fish Barrier Simulated Rescuer Touch Point Results, Operating Guidance, and Recommendations for Rescuer Safety – Final Report

## APPENDIX C SHORE TOUCH POINT DATA LOG

Table C-1. Test Condition 3 highest peak currents, all barriers operating.

Test Point Location	Test Point Description	Peak Current (mA)	Latitude, Longitude (WGS84)	
1A	Grounded to fence post	111	41.6412	-88.060567
1B	Earth ground	7	41.64105	-88.0606
1B	Grounded on old fence post	143	41.64105	-88.0606
1C	Grounded on metal sign	101	41.640867	-88.0606
1C	Earth ground, next to sign footing	13	41.640867	-88.0606
1D	Grounded on metal sign, under north edge of bridge	8	41.640767	-88.06065
1E	Earth ground, located on old bridge abutment	12	41.640667	-88.060667
1Z	Earth ground	49	41.64135	-88.060533
1Y	Earth ground	36	41.641533	-88.060483
1X	Earth ground	29	41.641633	-88.060617
1W	Earth ground	45	41.641733	-88.060617
1V	Earth ground	18	41.64185	-88.0606
1V	Grounded to old fence post	167	41.64185	-88.0606
2A	Earth ground	7	41.642033	-88.060517
2A	Grounded to old fence post	161	41.642033	-88.060517
2B	Earth ground	11	41.6421	-88.0605
2C	Earth ground	9	41.642217	-88.060483
2C	Grounded to old fence post	316	41.642217	-88.060483
2D	Earth ground	21	41.6423	-88.060483
2D	Grounded to old fence post	123	41.6423	-88.060483
2E	Earth ground	14	41.642367	-88.06045
2E	Grounded to old fence post	83	41.642367	-88.06045
2F	Earth ground	19	41.642533	-88.06045
2F	Grounded to electrical frame of parasitic connection	298	41.642533	-88.06045
2G	Earth ground	9	41.64265	-88.06035
2G	Grounded to stud on security fence concrete barrier	5	41.64265	-88.06035
2H	Earth ground	11	41.642767	-88.060367
2I	Earth ground	11	41.642867	-88.060367
3A	Earth ground	4	41.643117	-88.060383
3A	Grounded to metal sign post	7	41.643117	-88.060383
2J	Earth ground	18	41.642967	-88.060283
2K	Earth ground	4	41.642917	-88.060283
3B	Earth ground	2	41.64335	-88.0603
3C	Earth ground	3	41.643617	-88.06025
3D	Earth ground	2	41.644	-88.0602
3E	Earth ground	3	41.644267	-88.060217
3E	Grounded to metal sign post	7	41.644267	-88.060217



## CSSC Fish Barrier Simulated Rescuer Touch Point Results, Operating Guidance, and Recommendations for Rescuer Safety – Final Report

Table C-1. Test Condition 3 highest peak currents, all barriers operating (Continued).

Test Point Location	Test Point Description	Peak Current (mA)	Latitude, Longitude (WGS84)	
4A	Earth ground	13	41.644433	-88.060183
4A	Grounded to old fence post	45	41.644433	-88.060183
4B	Earth ground	13	41.644567	-88.060167
4C	Earth ground	4	41.644883	-88.060183
4D	Earth ground	8	41.645	-88.060167
4D	Grounded to metal sign post	30	41.645	-88.060167

Table C-2. Test Condition 3 highest peak currents, demonstration barrier and Barrier IIB only.

Test Point Location	Test Point Description	Peak Current (mA)	Latitude, Longitude (WGS84)	
1A	Grounded to fence post	43	41.6412	-88.060567
1A	Earth ground	10	41.6412	-88.060567
1B	Earth ground	2	41.64105	-88.0606
1B	Grounded on old fence post	22	41.64105	-88.0606
1C	Grounded on metal sign	74	41.640867	-88.0606
1C	Earth ground, next to sign footing	21	41.640867	-88.0606
1Z	Earth ground	5	41.64135	-88.060533
1Y	Earth ground	6	41.641533	-88.060483
1X	Earth ground	12	41.641633	-88.060617
1X	Grounded to electrical box	110	41.641633	-88.060617
1V	Earth ground	19	41.64185	-88.0606
1V	Grounded to old fence post	140	41.64185	-88.0606
2A	Earth ground	17	41.642033	-88.060517
2A	Grounded to old fence post	166	41.642033	-88.060517
2F	Earth ground	25	41.642533	-88.06045
2F	Grounded to electrical frame of parasitic connection	310	41.642533	-88.06045
2G	Earth ground	20	41.64265	-88.06035
2H	Earth ground	13	41.642767	-88.060367
2I	Earth ground	17	41.642867	-88.060367
3A	Earth ground	3	41.643117	-88.060383
3A	Grounded to metal sign post	11	41.643117	-88.060383
2J	Earth ground	3	41.642967	-88.060283
2K	Earth ground	5	41.642917	-88.060283
3B	Earth ground	3	41.64335	-88.0603
3D	Earth ground	3	41.644	-88.0602
3E	Earth ground	5	41.644267	-88.060217
3E	Grounded to metal sign post	7	41.644267	-88.060217





## CSSC Fish Barrier Simulated Rescuer Touch Point Results, Operating Guidance, and Recommendations for Rescuer Safety – Final Report

---

Table C-2. Test Condition 3 highest peak currents, demonstration barrier and Barrier IIB only.

Test Point Location	Test Point Description	Peak Current (mA)	Latitude, Longitude (WGS84)
4A	Earth ground	13	41.644433 -88.060183
4A	Grounded to old fence post	36	41.644433 -88.060183
4B	Earth ground	13	41.644567 -88.060167
4C	Earth ground	4	41.644883 -88.060183
4D	Earth ground	17	41.645 -88.060167
4D	Grounded to metal sign post	32	41.645 -88.060167



**This page intentionally left blank.**

