



**NAVAL  
POSTGRADUATE  
SCHOOL**

**MONTEREY, CALIFORNIA**

**THESIS**

**HOMELAND SECURITY ORGANIZATIONS: DESIGN  
CONTINGENCIES IN COMPLEX ENVIRONMENTS**

by

James D. Madia

September 2011

Thesis Co-Advisors:

Richard Bergin  
Christopher Bellavita

**Approved for public release; distribution is unlimited**

THIS PAGE INTENTIONALLY LEFT BLANK

<b>REPORT DOCUMENTATION PAGE</b>			<i>Form Approved OMB No. 0704-0188</i>
Public reporting burden for this collection of information is estimated to average 1 hour per response, including the time for reviewing instruction, searching existing data sources, gathering and maintaining the data needed, and completing and reviewing the collection of information. Send comments regarding this burden estimate or any other aspect of this collection of information, including suggestions for reducing this burden, to Washington headquarters Services, Directorate for Information Operations and Reports, 1215 Jefferson Davis Highway, Suite 1204, Arlington, VA 22202-4302, and to the Office of Management and Budget, Paperwork Reduction Project (0704-0188) Washington DC 20503.			
<b>1. AGENCY USE ONLY (Leave blank)</b>	<b>2. REPORT DATE</b> September 2011	<b>3. REPORT TYPE AND DATES COVERED</b> Master's Thesis	
<b>4. TITLE AND SUBTITLE</b> Homeland Security Organizations: Design Contingencies in Complex Environments		<b>5. FUNDING NUMBERS</b>	
<b>6. AUTHOR(S)</b> James D. Madia		<b>8. PERFORMING ORGANIZATION REPORT NUMBER</b>	
<b>7. PERFORMING ORGANIZATION NAME(S) AND ADDRESS(ES)</b> Naval Postgraduate School Monterey, CA 93943-5000		<b>10. SPONSORING/MONITORING AGENCY REPORT NUMBER</b>	
<b>9. SPONSORING /MONITORING AGENCY NAME(S) AND ADDRESS(ES)</b> N/A		<b>11. SUPPLEMENTARY NOTES</b> The views expressed in this thesis are those of the author and do not reflect the official policy or position of the Department of Defense or the U.S. Government. IRB Protocol number N/A	
<b>12a. DISTRIBUTION / AVAILABILITY STATEMENT</b> Approved for public release; distribution is unlimited		<b>12b. DISTRIBUTION CODE</b> A	
<b>13. ABSTRACT (maximum 200 words)</b> Protecting America from terrorism, natural disasters, and other threats has never been more important or as complex an endeavor as it is today. From asymmetrical warfare to economic meltdown, the environments are increasingly unstable, dynamic and complex, yet many U.S. homeland security organizations are designed around a 19th century model created for the Industrial Age. Information Age challenges demand new ideas for organizational design. Traditional mechanistic and hierarchical bureaucracies must be re-examined. This thesis explores case studies that include an intelligence organization fighting bioterrorism and a military unit battling insurgents in asymmetrical warfare. Case study research was selected to examine "how" and "why" questions related to organic organizational design in dynamic and complex environments. Organic designs provide a better fit because they leveraged three critical capabilities for these environments: communication dissemination, sense-making, and timely conversion of information to action. This fit is accomplished through elements, such as decentralized decision authority, emergent leadership, low specialization, low formalization, use of liaisons, and a reliance on performance controls, which in turn, contribute to decentralized allocation of decision rights, unconstrained patterns of interaction, and broad distribution of information. Organizations of the future will benefit from the insights that emerged from this research.			
<b>14. SUBJECT TERMS</b> Mechanistic, Organic, Hierarchical, Network, Organizational Design, Complexity, Complex Adaptive Systems, Uncertainty, Dynamic, Unstable Environment, Organization and Management Theory, Contingency Theory, Intelligence Organization, Command and Control, Terrorism, Asymmetrical, Network-Centric Warfare, Terrorism Early Warning Group			<b>15. NUMBER OF PAGES</b> 127
			<b>16. PRICE CODE</b>
<b>17. SECURITY CLASSIFICATION OF REPORT</b> Unclassified	<b>18. SECURITY CLASSIFICATION OF THIS PAGE</b> Unclassified	<b>19. SECURITY CLASSIFICATION OF ABSTRACT</b> Unclassified	<b>20. LIMITATION OF ABSTRACT</b> UU

NSN 7540-01-280-5500

Standard Form 298 (Rev. 2-89)  
Prescribed by ANSI Std. Z39-18

THIS PAGE INTENTIONALLY LEFT BLANK

**Approved for public release; distribution is unlimited**

**HOMELAND SECURITY ORGANIZATIONS:  
DESIGN CONTINGENCIES IN COMPLEX ENVIRONMENTS**

James D. Madia  
Lieutenant, Inglewood Police Department, Inglewood, California  
B.S., Union Institute and University, 2009

Submitted in partial fulfillment of the  
requirements for the degree of

**MASTER OF ARTS IN SECURITY STUDIES  
(HOMELAND SECURITY AND DEFENSE)**

from the

**NAVAL POSTGRADUATE SCHOOL  
September 2011**

Author: James D. Madia

Approved by: Richard Bergin  
Thesis Co-Advisor

Christopher Bellavita, PhD  
Thesis Co-Advisor

Harold A. Trinkunas, PhD  
Chair, Department of National Security Affairs

THIS PAGE INTENTIONALLY LEFT BLANK

## **ABSTRACT**

Protecting America from terrorism, natural disasters, and other threats has never been more important or as complex an endeavor as it is today. From asymmetrical warfare to economic meltdown, the environments are increasingly unstable, dynamic, and complex, yet many U.S. homeland security organizations are designed around a 19th century model created for the Industrial Age. Information Age challenges demand new ideas for organizational design. Traditional mechanistic and hierarchical bureaucracies must be re-examined.

This thesis explores case studies that include an intelligence organization fighting bioterrorism and a military unit battling insurgents in asymmetrical warfare. Case Study research was selected to examine “how” and “why” questions related to organic organizational design in dynamic and complex environments.

Organic designs provide a better fit because they leveraged three critical capabilities for these environments: communication dissemination, sense-making, and timely conversion of information to action. This fit is accomplished through elements, such as decentralized decision authority, emergent leadership, low specialization, low formalization, use of liaisons, and a reliance on performance controls, which in turn, contribute to decentralized allocation of decision rights, unconstrained patterns of interaction, and broad distribution of information.

Organizations of the future will benefit from the insights that emerged from this research.

THIS PAGE INTENTIONALLY LEFT BLANK



## TABLE OF CONTENTS

<b>I.</b>	<b>INTRODUCTION.....</b>	<b>1</b>
	<b>A. PROBLEM STATEMENT—BACKGROUND.....</b>	<b>1</b>
	<b>B. RESEARCH QUESTION .....</b>	<b>6</b>
	<b>1. Primary Question.....</b>	<b>6</b>
	<b>2. Secondary Questions.....</b>	<b>6</b>
	<b>C. THEORETICAL FRAMEWORK .....</b>	<b>7</b>
	<b>D. SIGNIFICANCE OF RESEARCH .....</b>	<b>7</b>
<b>II.</b>	<b>LITERATURE REVIEW .....</b>	<b>9</b>
	<b>A. COMPLEX ADAPTIVE SYSTEMS: UNDERSTANDING THE CONCEPTS.....</b>	<b>10</b>
	<b>B. COMPLEX ADAPTIVE SYSTEMS IN HOMELAND SECURITY: THE CHALLENGES .....</b>	<b>12</b>
	<b>C. ORGANIZATIONAL DESIGN: STRUCTURE AND PROCESS .....</b>	<b>14</b>
	<b>D. DESIGNING ORGANIZATIONS: MANY SCHOOLS OF THOUGHT .....</b>	<b>16</b>
	<b>1. Contingency Theory.....</b>	<b>17</b>
	<b>2. Analysis of Organizational Structures .....</b>	<b>19</b>
	<b>E. ORGANIZATIONAL CHARACTERISTICS: WHAT MATTERS IN COMPLEX DOMAINS?.....</b>	<b>22</b>
	<b>F. DESIGN OPTIONS: IT TAKES A NETWORK TO FIGHT A NETWORK .....</b>	<b>23</b>
	<b>G. CONCLUSION .....</b>	<b>25</b>
<b>III.</b>	<b>METHODOLOGY .....</b>	<b>27</b>
	<b>A. SAMPLE DATA.....</b>	<b>27</b>
	<b>1. Training Exercise “Operation Talavera” .....</b>	<b>27</b>
	<b>2. Operation Democratic National Convention 2000 (DNC) .....</b>	<b>28</b>
	<b>3. Training Exercise “Operation Chimera” .....</b>	<b>28</b>
	<b>4. Training Exercise Stryker Brigade Combat Team (CERTX) ....</b>	<b>28</b>
	<b>5. Stability Operations in Northern Iraq .....</b>	<b>29</b>
	<b>B. DATA COLLECTION .....</b>	<b>29</b>
	<b>C. DATA ANALYSIS .....</b>	<b>29</b>
	<b>D. THEORETICAL SENSITIVITY: ADDRESSING BIAS .....</b>	<b>30</b>
<b>IV.</b>	<b>CASE STUDIES: WHERE CONCEPT AND REALITY INTERSECT .....</b>	<b>33</b>
	<b>A. ORGANIZATIONS EXAMINED IN THE CASE STUDIES .....</b>	<b>34</b>
	<b>1. Los Angeles Terrorism Early Warning Group (TEW) .....</b>	<b>34</b>
	<b>2. Los Angeles Operational Area Unified Command (Operations) ..</b>	<b>36</b>
	<b>3. Stryker Brigade Combat Teams-U.S. Army (SBCT) .....</b>	<b>38</b>
	<b>4. 101st Airborne Division-U.S. Army (101st) .....</b>	<b>43</b>
	<b>B. CASE STUDIES-THE SCENARIOS.....</b>	<b>44</b>
	<b>1. Operation Talavera-Training Exercise—2004.....</b>	<b>44</b>
	<b>2. Operation Chimera-Training Exercise—2005 .....</b>	<b>49</b>

3.	Democratic National Convention—August 2000 .....	53
4.	Certification Exercise-Stryker Brigade Combat Team 2003.....	55
5.	Northern Iraq-Stryker Brigade Combat Teams 2003–2005.....	60
C.	CONCLUSION .....	69
V.	DATA ANALYSIS .....	73
A.	DISTILLATION PROCESS.....	74
B.	CONCLUSION .....	85
VI.	FINDINGS AND RECOMMENDATIONS .....	89
A.	FUTURE RESEARCH: INVESTIGATING THE DETAILS.....	92
B.	PRACTICAL IMPLEMENTATION OF THE FINDINGS .....	92
1.	Establishing Doctrine.....	92
2.	Leadership Development.....	93
3.	Training .....	94
	LIST OF REFERENCES .....	95
	INITIAL DISTRIBUTION LIST .....	105

## LIST OF FIGURES

Figure 1.	The TEW Organizational (Cell) Structure (From: Sullivan & Bauer, 2008) ..	36
Figure 2.	Incident Command Systems Organizational Structure (From: U.S. Department of Homeland Security, 2004) .....	37
Figure 3.	Operations Section Organizational Structure/Based on ICS (From: U.S. Department of Homeland Security, 2004) .....	38
Figure 4.	Network-Centric Operations Concept/Stryker Brigade Combat Team Organizational Doctrine (From: Rand Corporation, 2005).....	41
Figure 5.	Stryker Brigade Combat Team Lines of Development (From: Rand Corporation, 2005).....	42
Figure 6.	Stryker Brigade Combat Team Organizational Table (From: Wikipedia, 2008) .....	42
Figure 7.	The 101st Airborne Division Organizational Structure (From: <a href="http://www.militaryphotos.net">http://www.militaryphotos.net</a> , 2008).....	43
Figure 8.	Operation Talavera Images (From: IAFC <i>On Scene</i> , 2005) .....	49
Figure 9.	Operation Talavera Images (From: <a href="http://uuu.mindtel.com">http://uuu.mindtel.com</a> , 2011).....	49
Figure 10.	NCO/SBCT Command and Synchronization Options (From: Rand Corporation, 2005).....	60
Figure 11.	Map of the provinces of Northern Iraq (From: Rand Corporation, 2007) .....	63
Figure 12.	Map of Ninawah Province Iraq (From: Rand Corporation, 2007).....	63
Figure 13.	Stryker Armored Vehicle (From: <a href="http://www.ausa.org">http://www.ausa.org</a> , 2006).....	69
Figure 14.	Organizational Design Progression.....	91

THIS PAGE INTENTIONALLY LEFT BLANK

## LIST OF TABLES

Table 1.	Organizational Characteristics of Intelligence and Emergency Responder Organizations (From: LA TEW and Operations Section) .....	76
Table 2.	Organizational Characteristics of Military Organizations (From: 3/2 SBCT, 1/25 SBCT and 101st ABD) .....	76
Table 3.	Matrix of Elements Associated with the Allocation of Decision Rights/Based on Concept by Alberts and Nissen (From: Alberts & Nissen, 2009) .....	80
Table 4.	Matrix of Elements Associated with the Patterns of Interaction/Based on Concept by Alberts and Nissen (From: Alberts & Nissen, 2009).....	81
Table 5.	Matrix of Elements Associated with the Distribution of Information/Based on Concept by Alberts and Nissen (From: Alberts & Nissen, 2009).....	82

THIS PAGE INTENTIONALLY LEFT BLANK

## LIST OF DIAGRAMS

Diagram 1.	Rosetta Stone Model Depicting a Machine Bureaucracy and an Edge Organization/Based on Concept by Alberts and Nissen (From: Alberts & Nissen, 2009) .....	83
Diagram 2.	Rosetta Stone Model Depicting Mintzberg's Organizational Types and an Edge Organization/Based on Concept by Alberts and Nissen (From: Alberts & Nissen, 2009) .....	84
Diagram 3.	Rosetta Stone Model Depicting the SBCT and LA TEW/Based on Concept by Alberts and Nissen (From: Alberts & Nissen, 2009).....	85

THIS PAGE INTENTIONALLY LEFT BLANK



## LIST OF ACRONYMS AND ABBREVIATIONS

1/25 SBCT	1st Stryker Brigade Combat Team of the 25th Infantry Division, U.S. Army
101st ABD10	1st Airborne Division, U.S. Army
3/2 SBCT	3rd Stryker Brigade Combat Team of the 2nd Infantry Division, U.S. Army
5-20 Task Force	5th Battalion, 20th Infantry Regiment, U.S. Army
A/S Cell	Analysis & Synthesis Cell
ADR	Allocation of Decision Rights
AQ	Al-Qaeda (Terrorist Group)
AQAP	Al-Qaeda in the Arabian Peninsula (Terrorist Group)
Area G	Geographical area of Los Angeles County located in the South Bay
BTW	Bak, Tang, and Weisenfeld sand pile experiments (1987)
C/M Cell	Consequence Management Cell
C2	Command and Control
CAS	Complex Adaptive Systems
CDC	Center for Disease Control and Prevention
CEOC	Los Angeles County Operational Area Emergency Operations Center
CERTEX	Certification Exercise
CF	Conceptual Framework
CI	Critical Infrastructure
CIA	Central Intelligence Agency
CIP	Critical Infrastructure Protection
COP	Common Operating Picture
DARPA	Defense Advanced Research Projects Agency
DHS	Department of Homeland Security
DNC	Democratic National Convention (Los Angeles, 2000)
DOC	Los Angeles County Sheriff's Department Operations Center
DOI	Distribution of Information
EDGE	Decentralized Organizational Structure by David Alberts
Epi-Intel Cell	Epidemiological Intelligence Cell

F/S Cell	Forensic Support Cell
FARC	Revolutionary Armed Forces of Colombia-People's Army (Fuerzas Armadas Revolucionarias de Colombia (Terrorist Group))
FBI	Federal Bureau of Investigation
FEMA	Federal Emergency Management Agency
HLS	Homeland Security
HUMINT	Human Intelligence
HVT Operation	High-Value Target Operation (Mission)
I/L Cell	Investigative Liaison Cell
IACP	International Association of Chiefs of Police
ICS	Incident Command Systems
IED	Improvised Explosive Device
IPD	Inglewood Police Department
Iraqi NG	Iraqi National Guard
IRB	Institutional Review Board
JDAM	Joint Direct Attack-Munitions
JRTC	U.S. Army Joint Readiness Training Center - Fort Polk, Louisiana
LA	Los Angeles
LACO	Los Angeles County
LAPD	Los Angeles Police Department
LE	Law Enforcement
LeT	Lashkar-e-Toiba (Terrorist Group)
MIT	Massachusetts Institute of Technology
MS-13	Mara Salvatrucha, Transnational Criminal Organization
NCO	Network-Centric Operations
NCW	Network-Centric Warfare
NET Assessment	Intelligence Analysis and Future Projection
NSA	National Security Agency
NSSE	National Security Special Event
OA	Operational Area
OIC Cell	Officer-in Charge Cell
OMT	Organization and Management Theory
OPERATIONS Section	Los Angeles County Operational Area Unified Command- Operations Section
ORG Chart	Organizational Chart

P2P	Peer-to-peer
POI	Patterns of Interaction
PPE	Personal Protective Equipment
QHSR	Quadrennial Homeland Security Review, February 2010
RDD	Radiological Dispersal Device
REDDINET	Emergency Medical Computer Network linking hospitals
RPG	Rocket-Propelled Grenade
RPV Model	Resources-Processes-Values
RSTA	Reconnaissance-Surveillance-and-Target-Acquisition Squadron
SBCT	Stryker Brigade Combat Team, U.S. Army
SOC	Self-Organized Criticality
STAR	Business Model of Jay Galbraith-People, Strategy, Structure, Rewards and Processes
TAG	Public Health Technical Advisory Group
TEW	Los Angeles Terrorism Early Warning Group
TLO	Terrorism Liaison Officer
UAV	Unmanned-Aerial Vehicle
U.S.	United States
VBIED	Vehicle-Borne Improvised Explosive Device
WOT	War on Terror

THIS PAGE INTENTIONALLY LEFT BLANK

## ACKNOWLEDGMENTS

This thesis was the final stop of a spectacular journey, and perhaps the first step of my next one. It was an honor to be a part of such a wonderful group of homeland security professionals. My colleagues at CHDS added so much depth and richness to my experience.

I must thank my family, who sacrificed so much to enable my participation in this program. My wife, Cynthia, and children, Jennifer, Stephanie, Nicholas, Gabriella and Joseph, provided so much love and support over the past eighteen months. My focus on the academic endeavor meant that the family had to pickup the slack, which they did in so many ways. Thank you for your encouragement and love.

I certainly could not have succeeded without the tireless and dedicated guidance of my thesis advisors, Richard Bergin and Christopher Bellavita. They provided the foundation and inspiration for this thesis. Thank you for sharing your time, knowledge, wisdom, and experience. Your dedication to the research discipline and the creative process made this project possible. Thank you also to Lauren Fernandez for your help on my proposal. The distinguished professionalism and dedication of all the instructors and staff at the Center for Homeland Defense and Security helped me to surpass my expectations.

Thank you to Dr. Mark Nissen at the Naval Postgraduate School's Information Sciences Department. Dr. Nissen shared his expertise and his research so that I could discover an academic area that was new and exciting.

To the City of Inglewood, the Inglewood Police Department and Police Chief Jacqueline Seabrooks, thank you for allowing me the time to attend this distinguished program. A special thank you to Chief Phillip Sanchez, Percy Roberts, Terri Pond, Brent Woodworth, and Andrew Harvey, who helped make my attendance at CHDS a possibility.

THIS PAGE INTENTIONALLY LEFT BLANK

## I. INTRODUCTION

### A. PROBLEM STATEMENT—BACKGROUND

United States (U.S.) homeland security organizations routinely address issues in unstable, dynamic, and complex environments, where change can be rapid, unexpected, and adaptive. These complex environments exhibit uncertainty, emergence, and non-linearity. Traditional mechanistic and hierarchical organizational designs common to bureaucracies are not well suited to perform in such environments (Wise, 2002, p. 132). Some of the concerns that confront the homeland security enterprise include urban transportation networks, the power grid, expansive computer networks, transnational criminal and terrorist organizations, and U.S. economic infrastructure. Addressing these concerns includes the protection of people, places, institutions, and infrastructure, while detecting, disrupting, and preventing threats; and where appropriate, bringing adversaries to justice. The Quadrennial Homeland Security Review (QHSR, 2010) defines the homeland security enterprise as, "...the collective efforts and shared responsibilities of federal, state, local, tribal, territorial, nongovernmental, and private-sector partners..." charged with the protection of America from terrorism, natural disasters, and a variety of other threats and vulnerabilities. The bureaucratic organizations that comprise the homeland security enterprise guard America from the potential dangers of complex, unpredictable, and emergent self-organizing systems—complex adaptive systems. These systems exhibit a large number of heterogeneous and interacting elements, which make them difficult to analyze and understand (Carafano & Weitz, 2009, pp. 1–2; Axelrod & Cohen, 2000, pp. 7, 15). The unstable, dynamic, and complex environments generated by these systems often challenge the effectiveness and design of homeland security organizations.

Government bureaucracies are typically hierarchical organizations with centralized decision rights, concentrated organizational knowledge, narrow distribution of information, and constrained interaction among members. These organizations are often visually depicted diagrammatically on an organizational chart as a hierarchy. Many of

these organizations lack agility and a capacity for uncertainty and are commonly characterized as “mechanistic” (Alberts & Nissen, 2009; Tushman & Nadler, 1978; Mintzberg, 1979).

Hierarchical organizational design was developed during the Industrial Age in the late 19th and early 20th centuries. This design focused on organizational efficiency (Daft, 2009, p. 23; Dooley, 1997, p. 70; Alberts & Hayes, 2003, p. 37). Hierarchies have several advantages, including a clear concept of reporting relationships, authority, and organizational accountability. Organizations structured around a hierarchical form make use of specialization, division of labor, and coordination in pursuit of organizational goals (Daft, 2009, pp. 23–25, 90; Alberts & Hayes, 2003, pp. 41–43; Tucker, 2008, p. 3). This design was well suited for a time when a Newtonian, linear, and mechanized approach was the contemporary paradigm. The “machine” was the metaphor that shaped organizational design. Government organizations adopted hierarchical structure, which added approval layers and required that communication flow up through those layers, while decisions flowed from the top down (Tucker, 2008, pp. 3–4). This communication and approval path slowed organizational capacity to convert information into action. Hierarchies, therefore, exhibit poor capacity to change priorities or shift organizational resources quickly to meet a rapidly changing environment—the unstable, dynamic, and complex environment routinely encountered in homeland security. Government dependence on the hierarchical design has inhibited organizational agility (Kiel, 1994, pp. 1–6; Alberts & Hayes, 2003, pp. 72–75, 215).

In addition to the lack of organizational agility, hierarchical organizations are often unable to change tactics or processes to meet a changing domain—adaptability. This lack of organizational agility and adaptability stifle an organization’s ability to use information to anticipate issues, which produces a more reactive mode of operation. An illustration of this problem in homeland security has been observed in some of its intelligence agencies, which rely on timely and accurate information about emerging threats. In recent times, intelligence agencies have struggled to keep pace with the changing threats related to terrorism. Corman asserts that hierarchical organizations are



not well designed to deal with the adaptive nature of one aspect of terrorist organizations (Corman, 2005). He contends that terrorist organizations are in fact adaptive networks and a networked approach is required to combat them.

U.S. intelligence agencies did not anticipate the adaptation of al-Qaeda from a central command structure to the current collection of regional franchises and al-Qaeda inspired movements. Intelligence organizations also did not adjust well to the terrorists' adaptation of targeting and tactics. The thwarted, but nearly successful attack on Northwest Airlines flight 253, is a salient example of this issue. Nigerian-born Umar Farouk Abdulmutallab attempted to down an airliner by detonating a bomb concealed in his underwear. Only the quick action of alert passengers prevented the attack. Abdulmutallab was inspired by al-Qaeda in the Arabian Peninsula (AQAP) figure Anwar al-Awlaki and attended training at a camp in Yemen. U.S. intelligence personnel from various agencies had received information about Abdulmutallab and could have added him to the "no-fly list," but information stovepipes prevented the necessary communication exchange to identify him as a threat (Hosenball, 2010; DeYoung, 2009). This incident was an instance in which the government's hierarchical and mechanistic bureaucracies impeded information flow and failed to interact effectively.

This kind of communication failure is not new. Prior to the 9/11 terrorist attacks, a Federal Bureau of Investigation (FBI) agent in the Phoenix field office noticed peculiarities regarding flight school students and sent a memorandum informing FBI headquarters. Around the same time, agents in the Minneapolis field office began an investigation of Zacarias Moussaoui after a flight school reported his unusual behavior while attending lessons. In both cases, the FBI hierarchy did not accept or follow the recommendations of the agents, and the FBI personnel in Phoenix and Minneapolis were unaware of the cases in the other respective cities (Keane & Hamilton, 2004, pp. 272–276; Rowley, 2002). The hierarchical structure and rigid information and approval protocol in the FBI simply did not allow for decentralized communication flow.

Government organizations are often characterized as inflexible, cumbersome, overly large, unwieldy, and in some cases, obsolete (Kamarck, 2002, p. 6). Their hierarchical design is based on the Industrial Age models, which are not compatible with

contemporary concepts of agility and adaptability. Hierarchies are likely to fail in the complex adaptive environments of the Information Age (Alberts & Hayes, 2003, p. 56). Today's challenges negate previously held assumptions of predictability, order, and certainty, and require flexibility and adaptability (Daft, 2009, p. 30). Alberts and Hayes considered the problem of organizational hierarchies in the complex adaptive environment of the Information Age:

Industrial Age organizations are, by their very nature, anything but agile. Agile organizations must be able to meet unexpected challenges, to accomplish tasks in new ways, and to learn to accomplish new tasks. Agile organizations cannot be stymied when confronted by uncertainty or fall apart when some of their capabilities are interrupted or degraded. Agile organizations need to be able to tolerate (even embrace) disruptive innovation. Agile organizations depend upon the ability of individual members and organizational entities to get the information that they need to make sense of a situation and to combine and recombine as needed to ensure coherent responses. (Alberts & Hayes, 2003, pp. 59–60)

The concept of the large, unwieldy government bureaucracy can be illustrated in the Department of Homeland Security (DHS)—the largest organization in the homeland security enterprise. DHS has 220,000 employees distributed among 22 agencies. The department has an annual budget of 52 billion dollars (Homeland Security on the Hustings, 2008; DHS: Progress and Priorities II, 2008).

Hierarchical and mechanistic design has evolved around a reductionist view, in which challenges were well understood and solutions could be reached by breaking a problem down into its component parts. Dooley theorized that these ideas of reductionism, determinism, and equilibrium were based on the metaphor of management as a machine (Dooley, 1997, pp. 70–76). These assumptions helped to develop the modern management concepts of division of labor, standard operating procedures, and the organizational chart (Dooley, 1997, pp. 70–76). Complex adaptive systems, such as terrorist networks, often confound reductionism.

The concept of organizational design is not limited to a visual depiction on an organizational chart, but includes the interaction of various processes that work within the structure. These processes include how organizational members interact,

communicate, and make decisions. The combination of processes and structure determines how an organization is oriented, or how it is aligned and adapts within its environment—orientation. Organizational orientation can be broadly categorized between two general extremes—mechanistic and organic (Mintzberg, 1979). Mechanistic organizations are formalized, rigidly standardized, specialized, and bureaucratic, with a centralized command structure. This organizational form is most often associated with government bureaucracy. Organic forms are generally decentralized, with lateral interaction and distributed communication (Mintzberg, 1979). This research could have focused on the structural component by comparing hierarchical design to networked structure, but the more meaningful examination concerns the impact of mechanistic and organic design characteristics in unstable, dynamic, and complex environments.

An extensive body of literature and empirical research related to organizational principles exists, including mechanistic and organic designs. This body of work is often referred to as “organization and management theory” (OMT). The OMT literature suggests that no single organizational design is optimal in all situations, nor do all designs perform with equal effectiveness. The relationship between design and situational variables is critical (Galbraith, 1973, pp. 2–6; Galbraith, 1977, p. 28; Mintzberg, 1979, p. 11). This is the widely accepted concept known as contingency theory, which proposes that an organization must have the correct “fit” for its environment (Burns & Stalker, 2001; Woodward, 1981; Lawrence & Lorsch, 1967). One concept that is well supported in contingency theory is that organic organizational forms perform well in unstable—dynamic—and complex environments, while mechanistic designs are effective in stable and simple domains (Burns & Stalker, 2001; pp. 119–125; Lawrence & Lorsch, 1967, p. 188; Galbraith, 1973, p. 2; Galbraith, 1977, pp. 28–29; Mintzberg, 1979, pp. 270–277). Since the homeland security environment can be characterized in some situations as unstable, dynamic, and complex, in other words, a high degree of uncertainty, ambiguity, and non-linearity exists, with conditions changing quickly and often, the discussion of mechanistic and organic designs is a relevant one.

The apparent lack of organizational effectiveness associated with the 9/11 attacks and the Abdulmutallab case supports the assertion that homeland security organizations,

which are generally considered to be mechanistic, do not perform well in unstable, dynamic, and complex environments. Examination of this problem goes beyond a comparison of mechanistic and organic design. The salient question here is why do organic designs perform better in unstable, dynamic, and complex environments, and how does this happen?

Since unstable, dynamic, and complex environments exhibit rapid change, adaptation, uncertainty, unpredictability, and non-linearity, they require organizations that can collect and disseminate information rapidly and efficiently, can make sense of the situation quickly, and can convert that knowledge into timely and appropriate action. In this research, organizational performance is evaluated based on the ability to meet mission objectives, collect and disseminate accurate information at a tempo consistent with the environment, acquire shared situational awareness, promote organizational learning, and make timely and appropriate decisions to convert information into action and synchronize organizational efforts.

## **B. RESEARCH QUESTION**

### **1. Primary Question**

Why do organic organizational designs perform well in unstable, dynamic, and complex environments?

### **2. Secondary Questions**

How do organic organizational designs perform well in unstable, dynamic, and complex environments?

This thesis examines homeland security organizations operating in unstable, dynamic and complex environments to understand why and how a particular set of organizational characteristics associated with organic designs also contributes to performance in such environments.

### **C. THEORETICAL FRAMEWORK**

This research proposes that organizational characteristics, elements, and variables generally associated with organic organizational design also contribute to performance in unstable, dynamic, and complex environments. Based on this proposition, it is anticipated that those characteristics can be identified from a review of the literature and an examination of actual case studies in which organic organizations operated in unstable, dynamic, and complex environments.

This research seeks to support this general framework and to identify the specific characteristics for a better understanding of why and how organic forms perform well in such environments.

### **D. SIGNIFICANCE OF RESEARCH**

This research attempts to support the literature, which has established the concept of organizational fit and that organic designs perform well in unstable, dynamic, and complex environments. This research also seeks to explain why this occurs and how it works in practice.

Homeland security organizations that operate in unstable, dynamic, and complex environments can benefit from this research, by assessing the need to modify organizational design to meet varying degrees of instability and complexity. Intelligence agencies, military units, and public safety organizations tasked with the prevention of and response to terrorist attacks will better understand the nexus between organic organizational characteristics and the capacity to adapt and respond in unstable, dynamic, and complex environments.

Homeland security leaders can use this research as a foundation to implement policy that supports future development and assessment of organic organizational characteristics. It can be used as a guide to move organizational design to be more organic as the environment becomes more dynamic and complex, and to inform homeland security organizations better about why and how organic designs perform in unstable, dynamic, and complex environments.

THIS PAGE INTENTIONALLY LEFT BLANK

## II. LITERATURE REVIEW

The intent of this review of the literature is to provide a better understanding of why and how organic organizational designs perform well in unstable, dynamic, and complex environments. Meaningful observation and assessment of the relationship between organizational design and performance first requires some foundational understanding of the basic underlying concepts. For the purposes of this examination, the term “environment” is generally the surrounding, setting, or condition in which people and organizations perform particular activities. Specifically in this case, the organizations are homeland security organizations, and the activities performed are related to the detection, disruption, prevention, mitigation, response to, and recovery from terrorist attacks, natural disasters, and other threats to our security. Complex adaptive systems will be further described in detail in Section A of this review, but for now they can be described as non-linear, dynamic systems, which can be unstable and generally exhibit emergent properties. Therefore, for the purposes of this examination, complex adaptive environments are generally understood as non-linear, dynamic, and often unstable surroundings, settings, or conditions in which people and organizations perform particular activities, and where emergent properties, uncertainty, and unexpected rapid change are common.

This literature review establishes a foundational understanding of complex adaptive systems and organizational design theory, which is followed by an examination of recurrent ideas and some concepts on how homeland security organizations can perform effectively in emergent, uncertain, and complex domains.

In the opening Section A, the literature is synthesized to provide insight on the fundamentals of complex adaptive systems and complexity theory. A working definition of complex adaptive systems is developed to the degree that a single definition can be expressed to describe the phenomena fully. Section B focuses on complex adaptive systems that present a threat to U.S. security, and therefore, impact the homeland security

environment. The emergent and adaptive nature of complex systems generates unique challenges and establishes an environment of uncertainty for homeland security organizations. This section explores some of those challenges.

Section C explores organization from a structural view, where reporting authority and linkages define its design—topology. This section also examines a more conceptual and process-oriented perspective of organization, in which allocation of decision rights, patterns of interaction, distribution of information, specialization of labor, and systems thinking shape design—typology. Section D is an introduction to organizational design and identifies schools of thought and various organizational forms, including some specific designs deemed particularly relevant to this analysis.

The final two sections investigate potentially suitable organizational characteristics in complex adaptive environments and a detailed look at networked vs. hierarchical structures.

#### **A. COMPLEX ADAPTIVE SYSTEMS: UNDERSTANDING THE CONCEPTS**

John H. Holland is considered by many to be among a small group of researchers responsible for the term, Complex Adaptive Systems (CAS). Holland and his colleagues at the Santa Fe Institute proposed a theory that this world is permeated with various collections of adaptive and interactive agents that function within networks using simple sets of conditional rules that emerge as complex systems (Waldrop, 1992; Miller & Page, 2007). Most CAS authors use the term agent (Waldrop, 1992; Holland, 1995; Axelrod & Cohen, 2000) or actor having agency (Page, 2011, p. 250). Common dictionary definitions of agent include someone or something capable of producing an effect. Holland (1995) said that he “borrowed the term agent from economics” because it “is descriptive, but avoids preconceptions” (p. 7). Axelrod and Cohen (2000) said that an agent ...“has the ability to interact with its environment, including other agents” (p. 4). An agent could be anything from a person in a social system to an animal in an ecosystem. Agents could be computers on a network or grains of sand in a sand pile. In physiological systems, agents could be one of the hundreds of millions of neurons



performing thousand of simultaneous interactions in fractions of a second or self-organizing anti-bodies that fight a host of invading and ever-changing viruses (Waldrop, 1992; Holland, 1995; Lewis, 2006; Miller & Page, 2007; Page, 2011).

Beyond their basic description as networks of interactive agents, complex adaptive systems are nonlinear and adaptive. Brand (2009) characterized a nonlinear phenomenon where the “...output is not always proportional to its input—that, occasionally, unexpected, tiny changes in initial conditions provoke huge responses” (p. 9). Holland (1995) said that nonlinearity could be thought of as the whole being greater than the value of its parts (pp. 15–22). Thus, the agents can adapt in unexpected ways beyond a logical proportion to input. The results are emergence, self-organization, and uncertainty.

Holland uses the example of the game of chess, which features a game board with 64 squares and 16 game pieces per player. With a set of only two-dozen conditional rules, the number of possible game variations grows exponentially with each move (Holland, 1998, p. 1). One researcher estimated the possible number of chess game variations at 10,000,000,000<sup>50</sup>, but no precisely known number of game variations exists (Hardy, 1999, p. 17; Wolfram Math World). The salient point is that the interaction of moves among the game pieces [agents] creates huge variation and complexity. Chess provides a practical illustration of a complex adaptive system.

Bodhanya (2010) stated, “a complex adaptive system is a system comprised of heterogeneous agents that interact locally with each other based on local schema, such that the behavior of the system arises as a result of feedback relationships between the agents, and the system evolves as the schemata of the agents adapt based on the feedback.” Bodhanya echoed the arguments of Holland and other researchers that complex adaptive systems exhibit emergence, adaptation, and uncertainty.

Much of the literature uses the metaphor of the sand pile to describe the CAS phenomenon. In 1987, physicist Per Bak conducted a series of experiments with piles of sand to demonstrate the emergence of organized instability, or critical state, in which a single grain of sand added to the pile can cause a massive avalanche or no reaction at all

(Bak, 1996; Axelrod & Cohen, 2000, p. 105; Waldrop, 1992, pp. 304–306). Lewis (2011) goes into some depth on the 1987 Bak, Tang, and Weisenfeld (BTW) sand pile experiments. Lewis uses the term self-organized criticality (SOC) to describe this tipping point when complex systems are susceptible to catastrophe (pp. 9–26).

Dooley, Bodhanya, and many other authors use the term schema to describe the complex model in which agents interact. Dooley (1996) suggests that the agents strive for “fitness” within a schema, and this quest for fitness causes mutation, adaptation, and ultimate emergence from simplicity to complexity (p. 3).

Holland and the team at Santa Fe saw the implications of complexity science and complex adaptive systems not only in biological and natural systems, but also in economics, computer networks, sociology, psychology, and a wide array of human social interaction. They developed theories applicable to many aspects of modern life (Waldrop, 1992; Holland, 1995).

## **B. COMPLEX ADAPTIVE SYSTEMS IN HOMELAND SECURITY: THE CHALLENGES**

Bellavita (2006) stated, “...that the most significant strategic issues the homeland security community will face in the next ten years are in the unordered domain of complex adaptive systems.” Among the phenomena enumerated in Bellavita’s notion of that complex domain are terrorism, pandemics, nonstate threats, technology, networks, and resilience (pp. 8–9). Lewis also draws a connection between complex adaptive systems and homeland security. In describing the tipping point of complex adaptive systems, known as self-organized criticality (SOC), Lewis suggests that the SOC model can be used to study terrorist attacks, earthquakes, oil spills, power outages, and financial collapses (2011, p. 16).

Carafano and Weitz (2009) said that an understanding of complex systems was a requisite capacity for homeland security organizations. They listed national security concerns, such as terrorism, border security, and the protection of financial markets, as examples of complex phenomena (pp. 2–3). Beyond their partial list of complex issues

that influence the homeland security environment, Carafano and Weitz echo a common theme in the literature that local decisions in one part of the system can have unintended and unexpected consequences system-wide (pp. 2–3).

Much of the literature refers to case studies of al-Qaeda as evidence that terrorist organizations form complex adaptive systems. Bellavita specifically named al-Qaeda as a “complex homeland security issue” (Bellavita, 2006, p. 9). Al-Qaeda has been described as a flexible network that quickly adapts to external threats to its existence (Marion & Uhl-Bien, 2003, p. 54). The group’s structure has evolved into a bottom-up coordination and exhibits emergent characteristics typical of complex systems (Marion & Uhl-Bien, 2003, p. 54). Terrorist networks in general present an asymmetrical threat and manifest complex adaptive system characteristics (Lichtblau et al., 2006, p. 3; Wise, 2002, p. 132). Ahmed, Elgazzar and Hegazi stated emphatically, “it is obvious that terrorism is a CAS” (2005, p. 129). Ahmed et al. used an agent-based modeling approach to study al-Qaeda and concluded that terrorism must be studied as a whole and that one system can interact with another (pp. 4–5).

Sullivan (2010) added transnational organized crime networks to a growing list of threats “adapting and morphing” as they confront U.S. homeland security efforts. These groups have adapted to interdiction efforts and appear to continue their adaptation—blurring the lines between ideological insurgencies, terrorist networks, and organized criminal enterprise. Sullivan cites examples of traditional rebel movements and ideological insurgencies like FARC in Columbia and Shining Path in Peru, who now control drug operations and provide protection for the production facilities. He also refers to the burgeoning drug trafficking from Latin American to North Africa to supply Europe and how these various groups are becoming networked with each other. He suggests that many of these nonstate actors have accumulated such power that they are now on the verge of becoming pseudo states. Sullivan uses terms such as, “quasi-state, virtual statelets, dual sovereignty, no-go zones, lawless zones, de facto rulers, and parallel states.” Many of the Mexican drug cartels have destabilized government authority in various regions of Mexico and in other Latin American countries (pp. 180–187).

Another facet of the homeland security mission is the protection of critical infrastructure. Lewis (2006) described critical infrastructure sectors as, “infinitely complex” because of their interdependencies (p. 49). He refers to critical infrastructure as “emergent networks” (pp. 94–95). Lewis included power grids, oil pipelines, and transportation systems as examples of infrastructure that can be characterized as complex adaptive systems (p. 103). In a 2007 unpublished report, Lewis said that much of U.S. critical infrastructure is so complex that it is impossible to calculate the range of unintended consequences of a natural disaster or manmade incident, (2007, p. 1). The cascade failures of the power grid in 1996 and again in 2003 are examples of complexity and SOC affecting critical infrastructures (2006, p. 270). The impact on the transportation and economic sectors because of the September 11 terrorist attacks is an example of the interdependencies inherent in CI sectors (Bram, Orr & Rapaport, 2002; Homer-Dixon, 2002; Ito & Lee, 2005; Lewis, 2006).

Keeling and Eames (2005) analyzed epidemiological threats using the same network theory that Lewis used to model critical infrastructure. They list pandemic influenza and bioterrorist attacks as examples of complex systems that can be modeled as networks (pp. 304–305). They claim that these networks exhibit the emergent characteristics of complex adaptive systems and present challenges to homeland security organizations (pp. 304–305).

The self-organized critical state of complex adaptive systems as outlined by Holland and Lewis, is applied to natural disasters in the book, *Ubiquity: Why Catastrophes Happen*, by Mark Buchanan. Buchanan sites SOC to explain the stresses that build in earthquake faults, and ultimately, lead to seismic activity (2001, pp. 53–54) and conditions that influence the spread of forest fires (pp. 67–69). These disasters are yet more examples of complex issues facing homeland security today.

### **C. ORGANIZATIONAL DESIGN: STRUCTURE AND PROCESS**

Daft (2009) recognized one way to understand organizational design through the creation of hierarchies to achieve “organizational efficiency” (p. 23). He saw one aspect of design as a method for establishing reporting relationships and grouping people into

organizational units or elements (p. 90). This spatial depiction or topology to describe reporting relationships is expressed as a visual diagram—an organizational chart. Some of the structural examples of organizational forms outlined by Daft include the functional, divisional, multi-focused, team, horizontal, matrix, and networked (pp. 103–112). The FBI is an example of a functional hierarchy with its investigation, counterterrorism and counterintelligence, law enforcement services, and administration subsections, which are divided by the functions they perform (Federation of American Scientists, 2010). The Federal Emergency Management Agency follows a similar concept, but one part of the hierarchy is divided into regions that provide essentially the same function (FEMA, 2010), which follows a more divisional model.

Organizational design is often conceptualized in a purely structural context in the literature, which is the visual depiction of the diagrammatical organizational chart in which reporting relationships and linkages are expressed. The classic hierarchical structure commonly comes to mind in this example. One valid comparison is to contrast this structural component and its impact on organizational performance. This thesis project began as a comparison of a hierarchical structure to a networked structure. Validation in the literature and empirical data does exist to support a finding that hierarchical structures perform more optimally in simple environments with less uncertainty, while networked structures are better suited for uncertainty and complexity. However, organizational design research extends well beyond the understanding of organization simply as structure. This literature review exposed the relevance of organizational design, when thought of as process. This concept of process is described as a general method for interacting, coordinating, communicating, and making decisions. In Christensen’s (2003) RPV model (resources—processes—values), resources are “transformed” into values and the “patterns of interaction, coordination, communication, and decision-making through which this transformation occurs are the processes” (p. 187). Garvin (1998) had a similar view of processes, which he subdivided into “work, behavioral, and change” processes. The behavioral processes comprised interaction, communication, and decision-making. In Galbraith’s STAR Model (2001), processes are one vital component of design, and in particular, the lateral processes compare to

Garvin's behavioral processes. Therefore, for the purposes of this literature review and the forthcoming analysis, the process context of organizational design involves patterns of interaction, distribution of information (which includes an implied communication and distribution of knowledge), and allocation of decision rights. These variables of design were far more relevant to performance and this analysis than structure alone. The collective effects of these elements comprise the typology or classification of an organization, while the spatial depiction differentiates only its topology.

#### **D. DESIGNING ORGANIZATIONS: MANY SCHOOLS OF THOUGHT**

Organizational design and the study of organizations in general—referred to as Organization and Management Theory (OMT)—have been extensively examined in the literature, using at various times and by different researchers, different terminology, nomenclature, and schools of thought, which make meaningful comparison problematic. Some of the researchers and theorists include Fayol, Urwick, and Gulick (classical school), Mayo and Warner of the Hawthorne Study fame, Roethlisberger, Dickson, and Landsberger (human relations school), March, Simon, and Cyert (decision theory school), and Weber, Blau, Gouldner, and Crozier (bureaucratic school) to name a few (Lawrence & Lorsch, 1967, pp. 159–184), as well as Leavitt's diamond (Leavitt, 1965) and Galbraith's STAR (Galbraith, 2002; Kate & Galbraith, 2007).

Tafoya (2010) classified organizations into four design categories: enterprise, community, team, and individual contributor (p. 28). His highly conceptualized notion of organizational design does not use the organizational chart. Tafoya contends that most organizations are a blend of each of the four classifications with a heavier emphasis on one aspect depending on the type of organization and its mission (p. 28).

The Sloan School of Management at MIT was the genesis of Senge's notion of the "learning organization," where the systems within an organization came to characterize its design and organizational knowledge is more distributed throughout the workforce. Senge conceptualized the organization through the lens of systems thinking, which considers the entire business process in a holistic way rather than seeing snapshots from within compartmentalized structures (Senge, 2006, pp. 6, 65–66). Daft's version of

the “learning organization,” included a flattened structure to align with horizontal workflow. It can be modeled as a network because divisional and functional barriers have been removed to promote information sharing. Daft also discussed systems thinking and a culture of employee empowerment to encourage innovation and adaptation (Daft, 2009, pp. 31–34). According to Senge, learning organizations are inherently adaptive, and he cites Ford Motor Company’s information technology division and the Singapore police force as examples of adaptive organizations that employ learning organization principles (pp. 275–280).

The volume, diversity, and complexity of the various theories, schools of thought, terminology, and models abound. Therefore, an exhaustive study OMT for this research is impractical, impossible, and unnecessary.

## **1. Contingency Theory**

One school of thought in the OMT literature with particular relevance to this research is the contingency theory school. Contingency theory includes a set of ideas that can contribute to the standardization of terminology, the harmonization of competing theories, and a greater understanding of the impact of complexity—in this case, environmental complexity—as a variable on the relationship between organizational design and performance. Contingency theory is based on the notion that no single organizational design is best in all situations and not all designs perform with equal effectiveness. The relationship between design and situational variables is critical (Galbraith, 1973, pp. 2–6, Galbraith, 1977, p. 28; Mintzberg, 1979, p. 11). However, this is not a simple bivariate concept, where design (*D*) correlates to situation (*S*). A conditional variable (or variables), such as complexity (*C*) determines how *D* correlates with *S*; therefore, an example might be that when complexity is high, a particular design might perform poorly in a particular situation, but when complexity is low, the inverse would be true assuming that the variables *D* and *S* are the same. Contingency theory consistently examines the question of organizational fit for the situation. If contingency is

understood to be the variable that moderates the effect of organizational design on its performance, then the design must have the appropriate fit for the contingency (Donaldson, 2001, pp. 1–12; Galbraith, 1973).

Contingency theory is an accepted body of work within OMT, with a strong foundation of empirical research to support its conclusions. Nearly all of the contemporary OMT literature cites the seminal writings of Burns and Stalker (1961/2001), Woodward (1965/1981), and Lawrence and Lorsch (1967), as the origins of contingency theory and its premise that no single system of organization is best in all circumstances (Alberts & Nissen, 2009).

One recurrent comparison of design variables that has emerged in contingency theory is the mechanistic vs. organic debate. The classical school examined variables, such as centralization, formalization, standardization, unity of command, and hierarchical structure, which collectively came to be known as mechanistic when a high degree of all these elements exists (Burns & Stalker, 2001, pp. 119–120; Galbraith, 1977, pp. 28–29; Mintzberg, 1979, pp. 81–94). Organizations that exhibited decentralization, less formalization and standardization, a participatory nature, and a networked structure were considered to be organic (Burns & Stalker, 2001, pp. 121–125; Lawrence & Lorsch, 1967, p. 188; Galbraith, 1977, pp. 28–29; Mintzberg, 1979, p. 87). Tushman and Nadler (1978) referred to this organizational form as “organismic” (p. 617). Some authors use terms such as systemic or holistic in a similar fashion to organic. In the general sense, the literature described mechanistic organizations in reductionist terms and organic organizations in holistic terms.

Organizational forms do not always fall cleanly into one typology or another. Rather, the literature suggests that organizations can exhibit variables drawn from varying degrees of these two (mechanistic and organic) archetypes. Mintzberg (1979) suggested this concept through his identification of four basic designs: 1) the machine bureaucracy, 2) simple structure, 3) professional bureaucracy, and 4) adhocracy. Thus, organizational design can be visualized on a continuum where the mechanistic occupies one end and the organic is at the other. The machine bureaucracy is at the mechanistic end of the spectrum, and the adhocracy occupies the organic end of the continuum.



Mintzberg's other forms are variations, with a mixture of mechanistic and organic elements in varying degrees. Alberts and Hayes (2003) and Alberts and Nissen (2009) included the edge organization, which occupies a space on the continuum that could be characterized as more organic than the adhocracy, so the continuum is expanded to include edge organizations at the extreme organic end.

## **2. Analysis of Organizational Structures**

In general, contingency theory literature claims that mechanistic organizations offer a better fit in stable environments, while organic designs provide superior fit when greater uncertainty or rapid change is present (Burns & Stalker, 2001, pp. 119–125; Lawrence & Lorsch, 1967, p. 188; Galbraith, 1973, p. 4; Galbraith, 1977, pp. 28–29; Mintzberg, 1979, pp. 84–94). For the purpose of this research, Galbraith's (1973) definition of uncertainty is used, "...the difference between the amount of information required to perform the task and the amount of information already possessed by the organization" (p. 5). Since uncertainty is a consistent characteristic of complex environments, it is reasonable to infer from the literature that mechanistic forms have a better fit in simple environments, and organic forms have better fit in complex environments. Mintzberg (1979) specifically supports two hypotheses that reinforce this view:

- "The more dynamic the environment, the more organic the structure" (p. 270).
- "The more complex the environment, the more decentralized the structure" (p. 273).

Mintzberg's analysis contrasts stable environments with dynamic ones and complex environments with simple ones. He examines organic and decentralized organizational forms against mechanistic and hierarchical designs. He also suggests that Galbraith did not go far enough in his characterization of "uncertainty," for which Mintzberg would have substituted "complexity" (pp. 273–274).

Mintzberg (1979) described the machine bureaucracy as:

Highly specialized, routine operating tasks, very formalized procedures and large-sized units in the operating core, reliance on the functional basis for grouping tasks throughout the structure, little use made of training and of the liaison devices, relatively centralized power for decision making with some use of action planning systems, and an elaborate administrative structure with a sharp distinction between line and staff. (p. 315)

These organizations generally have little horizontal decentralization. Policies, standardized procedures, rules, and regulations dominate the organizational structure and members adhere strongly to a chain-of-command for communication and decision-making. Decision rights, information, and organizational knowledge are concentrated at the upper management level of the organization, which are classic vertical hierarchies with centralized authority—generally better suited for simple and stable environments. Large government institutions and manufacturing companies are included as examples of this design (Alberts & Nissen, 2009, pp. 315–346).

The simple structure is typically a small or young organization that relies on direct supervision for coordination. The simplicity of this form allows for centralized yet responsive decision making through informal interaction and less reliance on training, planning, or liaison devices. The simple structure is more organic than the machine bureaucracy. Examples of the simple structure include a small retail store or new government agency with a strong central leader (Mintzberg, 1979, pp. 305–312; Alberts & Nissen, 2009).

The professional bureaucracy is primarily a decentralized bureaucracy, in which homogeneity is achieved through the coordinating mechanism of standardization of skills. These organizations employ highly trained specialists—professionals—to perform most operational tasks. This level of training and specialization gives members a great deal of autonomy in their work. The work is done with little restriction from the hierarchy, and specialized members function independently of each other with coordination achieved through a standard set of skills, usually established by a regulatory body outside the organization. A high level of training is necessary for this model to perform effectively. Aside from the skilled professional workforce, many professional

bureaucracies utilize a less skilled support staff that functions more as a machine bureaucracy. Examples of professional bureaucracies include legal firms, medical groups, and schools (Mintzberg, 1979, pp. 348–371; Alberts & Nissen, 2009).

Mintzberg's (1979) adhocracy is an organic, decentralized structure with little formalization, considerable horizontal job specialization through extensive training, and a heavy reliance on liaison devices as a coordinating mechanism. Decision rights are distributed, and interaction tends to be peer-to-peer. Adhocracies can bring technical experts together from various disciplines to form functional teams, which fosters innovation (pp. 431–467; Alberts & Nissen, 2009).

Alberts and Hayes (2003) developed the concept of the edge organization, which is not dissimilar to the learning organization described by Senge and Daft. Edge organizations are also structurally flatter in the sense that decision rights, information, and organizational knowledge are distributed. Alberts and Hayes modeled edge organizations as networks. Considering this network topology, the phrase “pushed out” would be appropriate to describe authority; hence the title, *Power to the Edge*, because the organization's knowledge and control—its power—is pushed out to its edges (Alberts & Hayes, 2003, pp. 206, 216–217).

The networked design of edge organizations fosters greater interaction between and among all of its members. This enhanced interaction arguably moves information through the organization with greater speed, accuracy, and efficiency than a traditional mechanistic hierarchy. Alberts and Hayes argue that these qualities make edge organizations more agile than mechanistic hierarchies. Therefore, they reason that edge organizations are a good fit for the uncertain, dynamic, and emergent environments (Alberts & Hayes, 2003, pp. 206, 216–217). Edge organizations synthesize elements of many archetypes, yet they form a distinct design (Alberts & Nissen, 2009). Edge organizations can be characterized as meritocracies that exhibit emergent leadership (Alberts & Nissen, 2009).

## **E. ORGANIZATIONAL CHARACTERISTICS: WHAT MATTERS IN COMPLEX DOMAINS?**

Alberts and Hayes (2003) cited the need for agility as an imperative for Information Age organizations. They argue that agility may be the defining characteristic of effective organizations operating in the complex space (pp. 56, 123). Alberts and Hayes propose that agile organizations with a decentralized structure, and that promote innovation, are best suited to contend with unexpected events in rapidly changing domains (pp. 59–60). They theorize that agility is achieved through a combination of organizational elements that includes both structural and conceptual design. Their definition of agility is comprised of components including responsiveness (the capacity to exploit opportunities quickly), flexibility (the ability to meet objectives using various approaches), adaptability (the capability to change tactics to meet changing domains), and innovation (the capacity to utilize new techniques and resources) (pp. 141–151). This emphasis on agility and its constituent characteristics is echoed in the literature (Daft, 2009, pp. 25–30; Bell & Joroff, 2001, p. 10).

Senge (2006) took a process-oriented approach by focusing on “interrelationships” (pp. 42–47). In Senge’s view, systems are developed to influence how the organization operates. These systems form the “fabrics of interrelated actions” (p. 7). Systems thinking is the process of understanding these interrelationships as a whole (p. 68). Senge claims that some of the most complex organizational problems can be effectively addressed through systems thinking (p. 66). One of his examples is the war on terrorism, which Senge depicts as a cyclical system. All participants understand their role in the war from their particular perspective, but few see the whole system, even though every part of the system has a profound influence on the other parts. Thus, threats lead to action, which leads to reaction, and the cycle continues perpetually (pp. 70–71). Poor organizational design can cause similar blind spots, such as when the upper-level management is centralized and holds most of the organization’s vital information, which is compounded by compartmentalization that occurs within the structure to facilitate division of labor. Senge argues for a decentralized form, in which institutional knowledge

is diffuse (pp. 70–71). Hence, a parallel can be drawn to Alberts and Hayes’ notion of the edge organization in which organizational knowledge and information are propagated throughout the organization (2003, pp. 206, 216–217).

Much of the literature suggests that agility is achieved in flatter organizational designs in which approval layers have been reduced and decision rights pushed down to the lower levels of the organization. Daft (2009) contends that in a dynamic, rapidly changing environment, the traditional hierarchy becomes overwhelmed. He recommends the concept of the learning organization (p. 31). Daft builds upon earlier work by Galbraith, who proposed that hierarchies become overwhelmed as uncertainty increases, as is the tendency in emergent and complex environments (Galbraith, 1974, p. 29). Kiel (1994) suggests that flat organizational structure optimizes efficiency. He characterizes this flattened design concept as “ideal,” and claims that, “flatter is better.” However, he adds that structure and business process must work interactively to maximize effectiveness in complex environments (pp. 155–157, 190).

#### **F. DESIGN OPTIONS: IT TAKES A NETWORK TO FIGHT A NETWORK**

Another organizational design theme that emerges from the literature is the use of networked topology to optimize multilateral communication, and thereby, promote organizational agility and adaptability. Networked teams demonstrate the capacity to work collaboratively across multiple functions to optimize agility and adaptability (Daft, 2009, pp. 31–33). Alberts and Hayes (2003) characterize this structure as a “robustly networked force,” which they claim will outperform hierarchies in sense-making and adaptability in complex and nonlinear environments (pp. 90–93, 181–184). Lewis added, “networks beat hierarchies in the business world, and now we are beginning to realize that networks beat hierarchies in the world of politics and wars” (2007, p. 11). This claim was an expansion of his earlier writing where Lewis describes the removal of middle management to form a “dis-intermediated command hierarchy” (2006, pp. 13–14). He repeated the often-quoted phrase, “it takes a network to fight a network” (p. 12). Corman

(2005) also subscribes to this belief. Lewis agrees with Daft, Alberts, and many others who reason that hierarchies are too slow to react and often stifle organizational communication.

Tucker (2008) rejects the notion, “it takes a network to fight a network,” as some have suggested (p. 2). He contends that it is more important for an organization to be well adapted to its environment than to be concerned about its organizational structure or that of its enemy (p. 2).

Leavitt (2005) cites a variety of practical and even emotional reasons that hierarchies will and should continue to exist as the primary organizational form. He added that the notion of hierarchy has changed to some degree with the introduction of participative management, analytic management, and “hot groups,” but that hierarchies are essentially “here to stay” (pp. 69–82).

Tucker considers the relative advantages and disadvantages of both hierarchies and network topology. In hierarchies, information moves upward, while decisions flow down from the top, which develops a framework for “legitimate and accepted authority” linked to an individual’s rank or position in the organization. Hierarchies are rooted in a system of rules and regulations and ensure accountability and efficiency (Tucker, 2008, p. 3; Leavitt, 2005, p. 40). Some of the disadvantages of a hierarchical model include the possibility that critical information will move too slowly through the organization due to the need for approval at various layers of command and that information can also be filtered or distorted, which could lead to poor decisions (Tucker, 2008, pp. 3–4).

As organizational structure flattens, the decreased levels of approval and authority facilitate faster and more accurate information flow with less filtering, but Tucker worries that faster decisions are not necessarily better (p. 4). Flatter structures and more distributed decision authority could lead to a loss of central control and accountability. Although Tucker acknowledges that networks offer an effective alternative to hierarchies in some settings, he argues that networks are not necessarily the right choice in all situations. While they can be highly adaptive and respond quickly to changes in the environment, networks can also be risky and unpredictable (Tucker, 2008, pp. 3–4).

Tucker concludes that neither organizational design is preferable in all situations and suggests a more flexible form that can offer positive characteristics of both. Sometimes the operational environment or the tasks to be performed favor networks, and other times they favor hierarchies (pp. 3–4). The literature generally supports a hypothesis that no single organizational design is optimal in all circumstances (Powley & Nissen, 2009, p. 3). Powley and Nissen refer to a body of prior research that recommends a more flexible, agile, and adaptable organizational design to address a variety of situations ranging from simple to complex (p. 4).

## **G. CONCLUSION**

The literature supports the argument that in unstable, dynamic, and complex environments, organizations should be designed for agility, responsiveness, flexibility, adaptability, and innovation. Organizations facing complexity should be structured to maximize sense-making, rapid situational awareness, information sharing, and organizational learning. The edge organization of Alberts and Hayes or the learning organization of Daft and Senge offer these characteristics with their flatter design, reduced layers of authority, distributed decision rights, and imbedded networks for rapid multilateral information sharing and decision-making capacity.

While the network topology pushes decision authority down to the operational level and allows for greater agility and adaptability, it is not ideal for all situations. Hierarchies are still optimal in routine and simple domains, which suggests that a flexible, hybrid organization may be well-suited for homeland security organizations that encounter both routine and complex challenges. Since most organizations face environments that include simple, complicated, complex, and at times, chaotic elements, the exploration of a hybrid structure that can flex between hierarchical and network concepts is worthy of continued research.

Gaps in the literature exist regarding how specifically to design such a flexible hybrid organization. Currently, a clear idea of why organic forms perform well in dynamic and complex environments or how they work does not exist.

THIS PAGE INTENTIONALLY LEFT BLANK



### III. METHODOLOGY

The goal of this research was to seek a better understanding of why and how organic organizational designs perform well in unstable, dynamic and complex environments. The case study method was selected to examine actual organizations operating in unstable, dynamic and complex environments, in which such an examination does not lend itself to repeatable experiments or easily controlled sets of variables. Also, “how” and “why” questions are well matched to the case study method. The use of the case study method facilitates the exploration of complex phenomena; in this case, the study of organizations, allowing for the deconstruction, reconstruction and fuller understanding of such phenomena (Yin, 2009; Baxter & Jack, 2008; Stake, 1995).

#### A. SAMPLE DATA

This research examined the design of four organizations, although it focused primarily on the two organic ones. The examination of the organizations was done within the context of specific operational missions and training exercises, which defined the cases or units of analysis. These cases were bounded within the timeframe that each organization conducted the specific operational mission or training exercise. This sample data was selected because it offered an opportunity to observe organic organizations operating in unstable, dynamic and complex environments and allowed for further deconstruction to understand better why these organizations performed well and how they did so.

The sample data included published books, reports, articles, operational plans, after actions reviews, evaluations and past theses related to the operational missions and training exercises that comprised each case:

##### 1. Training Exercise “Operation Talavera”

These data samples included a published book, *Terrorism Early Warning: 10 Years of Achievement in Fighting Terrorism and Crime*, edited by one the co-creators of the Los Angeles (LA) Terrorism Early Warning Group (TEW), John P. Sullivan. The

samples also included published articles, theses, operational plans, after actions reports, and evaluations related to Operation Talavera, the Los Angeles Unified Command and the TEW. This researcher was also an observer/participant at Operation Talavera. These data samples provided a description of the operation, the organizational design approach of the unified command and the TEW, and their performance during the operation.

## **2. Operation Democratic National Convention 2000 (DNC)**

These data samples included a published book, *Terrorism Early Warning: 10 Years of Achievement in Fighting Terrorism and Crime*, edited by one the co-creators of the Los Angeles Terrorism Early Warning Group (TEW), John P. Sullivan. The samples also included published articles, theses, operational plans, after actions reports, and evaluations related to Operation DNC, and the TEW. These data samples provided a description of the operation, the organizational design approach of the TEW, and its performance during the operation.

## **3. Training Exercise “Operation Chimera”**

These data samples included a published book (2008), *Terrorism Early Warning: 10 Years of Achievement in Fighting Terrorism and Crime*, edited by one the co-creators of the Los Angeles Terrorism Early Warning Group (TEW), John P. Sullivan. The samples also included published articles, theses, operational plans, after actions reports, and evaluations related to Operation Chimera, and the TEW. These data samples provided a description of the operation, the organizational design approach of the TEW, and its performance during the operation.

## **4. Training Exercise Stryker Brigade Combat Team (CERTEx)**

These data samples included a book published by Rand Corporation (2005), *Network Centric Operations Case Study: The Stryker Brigade Combat Team*. The samples also included published articles related to the CERTEx Operation and the Stryker Brigade Combat Team (SBCT). These data samples provided a description of the operation, the organizational design approach of the SBCT, and its performance during the operation.

## **5. Stability Operations in Northern Iraq**

These data samples included a book published by Rand Corporation (2007), *Networked Forces in Stability Operations: 101st Airborne Division, 3/2 and 1/25 Stryker Brigades in Northern Iraq*. The samples also included published articles related to the Stability Operation in Northern Iraq and the Stryker Brigade Combat Teams (3/2 and 1/25) (SBCT), and the 101st Airborne Division (101st ABD). These data samples provided a description of the operations, the organizational design approach of the SBCTs and 101st ABD, and its performance during the operations.

### **B. DATA COLLECTION**

Most of the data was available online and collected from the worldwide web, or was already in the author's possession and under his control prior to this research. The secondary case studies related to the Stryker brigade combat teams were purchased from the Rand Corporation.

### **C. DATA ANALYSIS**

In this multiple case study, several cases were examined to understand the similarities and differences between the organizations within each case. This examination led to the identification of phenomena that expanded the understanding of why and how certain forms fit particular environments.

The proposition that organic organizational designs perform well in unstable, dynamic and complex environments was a fundamental theme in the literature. The data were analyzed with this proposition as a starting assumption. The literature also provided a collection of key organizational characteristics that contributed to an organization's performance in unstable, dynamic and complex environments, but also related to its organic design, which included agility, responsiveness, flexibility, adaptability and innovation (Mintzberg, 1979; Alberts & Hayes, 2003; Alberts & Nissen, 2009). The organizations in each case study were evaluated for their manifestation of these characteristics during the timeframe of the case. The organizations were also evaluated using questions gleaned from the literature to establish and validate their effectiveness in

the particular environments presented during the case studies, which was the standard used to determine effectiveness or effective performance. The organizational characteristics were then distilled down to basic elements that contributed to an organization's performance in unstable, dynamic and complex environments, but also related to its organic design that included centralization, specialization, formalization, the use of liaisons, planning and control systems, and the support for emergent leadership (Mintzberg, 1979; Alberts & Nissen, 2009). The organizations in each case study were evaluated for the presence of these elements during the timeframe of the case. The elements were then applied to the Alberts and Nissen (2009) Rosetta Stone Model to relate them to the three thematic variables, allocation of decision rights, patterns of interaction and distribution of information. The organizations were depicted in a three-dimensional space to determine their relative orientation.

The analysis was then applied to the demands and challenges presented by dynamic and complex environments. These demands and challenges were evident in the literature and reasonably obvious in each of the case studies. This process provided insights into the question of why and how organic forms perform well in dynamic and complex environments. Most of the information was organized into a series of tables or matrices to facilitate its assembly, organization, and distillation.

#### **D. THEORETICAL SENSITIVITY: ADDRESSING BIAS**

Since researchers nearly always enter into the research environment with some level of bias and various levels of sensitivity, that issue must be acknowledged in this research. This sensitivity is shaped by the researcher's personal and professional experience, which adds depth to their knowledge in the area of study and allows for the development theories "grounded, conceptually dense, and well integrated," but can also bias their analysis (Strauss & Corbin, 1990). This researcher is an experienced homeland security, law enforcement and public safety professional with 27 years of training and actual field experience. He was also a participant-observer during Operation Talavera and a designated Terrorism Liaison Officer (TLO) associated with the TEW. He was also personally familiar with Operation Chimera and the DNC, and was personally acquainted

with many of the participants of those operations. Based on personal and professional relationships with members of the TEW over the course of many years, the researcher was party to many incidental conversations regarding the details of the case study operations prior to this research, and therefore, had personal knowledge as to much of the data. While this fact added depth and richness to the analysis, it required vigilance for bias and a healthy dose of skepticism to mitigate that bias, which allowed him to validate the literature and other data for its credibility (Strauss & Corbin, 1990; Trochim & Donnelly, 2006).

A consistent strategy of triangulating among the literature, case study data, and personal experience went a long way towards the identification and understanding of biases introduced into the study and in seeking to mitigate the influence of those biases in the analysis phase of the study. As themes emerged from the case study analysis, they were validated through correlation with professional knowledge and experience, along with established concepts in the foundational literature. Further validation was achieved by mapping analysis back to the research questions and the demands of the environment. Unstable, dynamic and complex environments are rapidly changing, adaptive and replete with uncertainty. These environments demand a capacity to collect and disseminate information rapidly and accurately, while making quick sense of that information to achieve shared situational awareness. Ultimately, these environments also demand the rapid and efficient conversion of information into action, achieved through sound decision making often based on ambiguous information. Correlated themes derived from the analysis, literature and professional experience had to constantly be assessed against these environmental demands to guard against biasing the findings. This systematic process kept the research credible, academically rigorous, and relatively free of bias induced assumptions and conclusions.

THIS PAGE INTENTIONALLY LEFT BLANK

#### **IV. CASE STUDIES: WHERE CONCEPT AND REALITY INTERSECT**

The following case studies were examined to better understand how contingency theory; the well-established concept in the literature on organizational “fit” (Burns & Stalker, 2001; Woodward, 1981; Lawrence & Lorsch, 1967) explains the use of alternative designs under attenuating circumstances. One finding well supported in the contingency theory literature is that organic organizational forms perform well in unstable—dynamic—and complex environments, while mechanistic designs are effective in stable and simple domains (Burns & Stalker, 2001, pp. 119–125; Lawrence & Lorsch, 1967, p. 188; Galbraith, 1973, p. 2; Galbraith, 1977, pp. 28–29; Mintzberg, 1979, pp. 270–277). The case studies in this research illustrated how well the involved organizations performed in each scenario, whether they were structured to be organic, and what steps (if any) they took to achieve fit. The environments encountered in each case were presumed to be unstable and complex since a high degree of uncertainty, ambiguity and non-linearity existed, and the environments were certainly dynamic—with conditions changing quickly and often.

In some cases, only one organization—identified as organic in design—was examined to investigate key actions taken, processes implemented or elements incorporated that made the organization both effective and organic, but also to elicit how this contributed to its effectiveness. In other cases presented here, organic organizations were compared to more mechanistic ones that participated in the same operation or exercise. Although the research is presented with a basic presumption based on the literature that organic organizations perform effectively in unstable and complex environments, while mechanistic organizations do not, the comparisons added to the exploration of specific elements that either enhanced or degraded performance in such environments. Ultimately, these case studies were aimed at answering both the “why” and “how” questions. Why do organic forms perform better in unstable and complex environments? How does organic design contribute to improved performance in unstable

and complex environments? To attempt to answer these questions, this research first had to address how these particular organizations achieved a more organic design, and thereby improved their performance.

The case studies used for this research comprised five operations, which included three training exercises (Talavera, Chimera and CERTEX) and two real life operations (DNC and Northern Iraq). Three of the cases (DNC, Talavera and Chimera) involved domestic intelligence and public safety response organizations performing various aspects of the homeland security mission. Two of the cases (CERTEX and Northern Iraq) involved elements of the U.S. military in a training exercise and a combat mission that pitted them against terrorist and insurgent groups. Operations Talavera and Northern Iraq included direct comparisons of organic organizations to mechanistic organizations in the same unstable and complex environment.

#### **A. ORGANIZATIONS EXAMINED IN THE CASE STUDIES**

The case studies were conducted to examine organizational performance in unstable and complex environments, and each case did present dynamic and complex environmental elements. The particular organizations selected for investigation were chosen based on their organizational design and how that design influenced performance during each scenario. The following organizations were investigated.

- Los Angeles Terrorism Early Warning Group (TEW)
- Operations Section of the Los Angeles County Operational Area Unified Command for Operation Talavera (Operations)
- Stryker Brigade Combat Teams, U.S. Army (SBCT)
- 101st Airborne Division, U.S. Army (101st ABD)

##### **1. Los Angeles Terrorism Early Warning Group (TEW)**

The TEW has been described as a “multi-lateral, multi-jurisdictional, multi-disciplinary intelligence network” comprised of functional teams or “cells” and a cadre of Terrorism Liaison Officers (TLO) that represent and report back to their respective agencies (Sullivan, 2000; Sullivan, 2005; Sullivan & Bauer, 2008; Miller, 2005;



Grossman, 2005). The organization of TEW was constructed from a wide spectrum of public safety, intelligence, governmental and non-governmental personnel contributed by their respective agencies.

Structurally, the TEW was organized into six functional teams called “cells,” which consisted of the (1) officer-in-charge or OIC Cell (OIC), (2) analysis/synthesis cell (A/S), (3) consequence management cell (C/M), (4) investigative liaison cell (I/L), (5) epidemiological intelligence cell (Epi-Intel) and (6) forensic support cell (F/S), which included technical resources in support of the other cells (Sullivan & Bauer, 2008, pp. 29–31). The cells were visually depicted on the TEW organizational chart as a network, and the organization has been consistently characterized as “networked” (Sullivan & Bauer, 2008; Rust, 2006; France, 2006). Based on their concept of operation (Sullivan & Bauer, 2008, pp. 61–93), the TEW model encouraged decentralized decision-making, peer-to-peer interaction, emergent leadership, reliance on liaison devices, broad distribution of information, and other characteristics indicative of organic design. The examination of the TEW in the context of the cases presumed an organizational orientation toward the organic end of the continuum.

Lastly, the TEW defined its organizational roles and responsibilities based on the nature of the threats encountered in each situation and the organization presumed that it would be operating in complex environments (Sullivan & Bauer, 2008, pp. 29–31, 73).

## The TEW Cell Structure

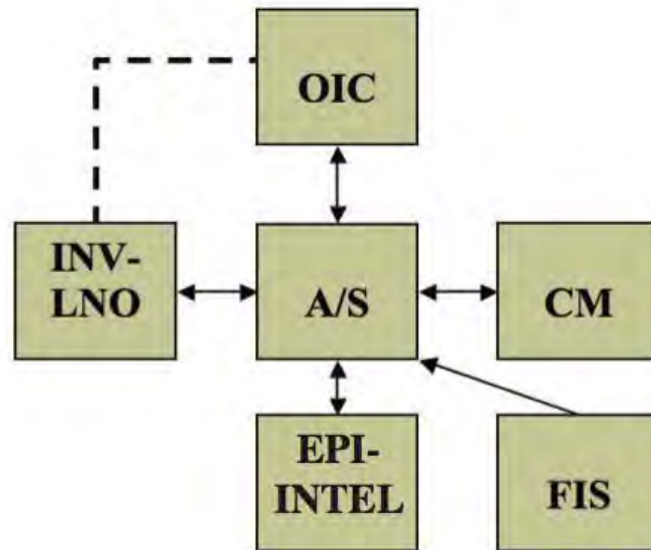

Figure 1. The TEW Organizational (Cell) Structure (From: Sullivan & Bauer, 2008)

### 2. Los Angeles Operational Area Unified Command (Operations)

The first responder agencies from the Los Angeles County Operational area came together in December 2004 to participate in a training exercise called, “Operation Talavera” (Gardner, 2005). The organization created for the exercise was based on a concept known as unified command within the framework of incident command systems. This design is a hierarchical structure that establishes layers of command and reporting relationships under an incident commander and four functional sections: (1) operations, (2) planning, (3) logistics, and (4) finance. In unified command, the control of each section is collaboratively maintained by the primary agencies participating in the operation. In the case of Operation Talavera, the operations section was under the joint command of two section chiefs, a police lieutenant and an assistant fire chief. The operations section (operations) of the unified command structure for Operation Talavera was the focus of investigation for this research.

The operations section was organized into discipline “branches” and functional “groups” under the command of group leaders (usually police lieutenants and sergeants or fire department battalion chiefs). One example of a functional group was the crowd control group, which consisted of police officers from the Area G South Bay Mobile Field Force Platoon. Their tasks included maintaining order and discouraging acts of civil unrest during the mass decontamination process. Their group leader reported through the branch command to the operations section chiefs. Requests for resources, situation updates, tasking and all other related communication to and from the crowd control group had to be routed to the operations section chiefs, as was the case for all of the groups organized under the operations section. Groups could not send requests for resources directly to the logistics section, but had to follow the chain-of-command.

The organizational design included centralized decision authority, constrained interaction between groups of the various command elements, concentrated information flow, high degree of functional specialization, knowledge dissemination consistent with what each individual required to perform their tasks, and the limited use of liaison devices. Based on the visual depiction of the organizational structure and its processes at Operation Talavera, the operations section in this context was presumed to have an organizational orientation toward the mechanistic end of the continuum.

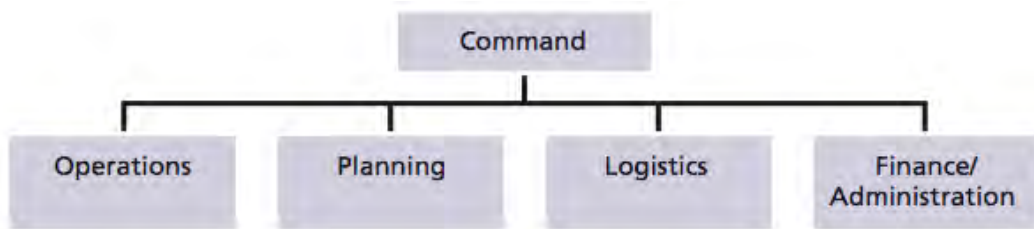

Figure 2. Incident Command Systems Organizational Structure (From: U.S. Department of Homeland Security, 2004)

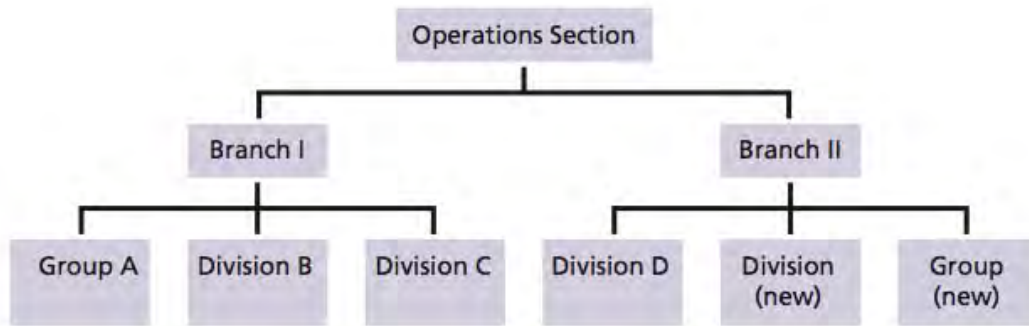

Figure 3. Operations Section Organizational Structure/Based on ICS (From: U.S. Department of Homeland Security, 2004)

### 3. Stryker Brigade Combat Teams-U.S. Army (SBCT)

The Stryker Brigade Combat Team (SBCT) is one of the U.S. Army's newest organizational units. The SBCT was created out of a need by the Army to possess a flexible and rapidly deployable force in dynamic environments, but also to sustain operations for longer duration. Traditionally, the Army utilized primarily either highly sustainable heavy forces, slow to react and difficult to deploy, or light units, which deploy rapidly, but were not well designed for sustained missions (Vick et al., 2002; Gonzales et al., 2005; Association of the United States Army, 2006). The SBCT was the Army's proposed solution to both problems. The SBCT is a medium brigade-sized force equipped with a wheeled, fast moving, armored vehicle that can move personnel over great distances in a short period of time. The brigade was built for rapid deployment and has been mostly brought into theaters of operation on C-5 and C-17 aircraft (Vick et al., 2002; Gordon & Orletsky, 2003). SBCTs can reportedly be anywhere in the world in 96 hours, compared to a division at approximately 120 hours and five divisions in 30 days. They possess the lethality and mobility of a light unit, but with the sustainability and survivability of heavy forces (Vick et al., 2002; Gonzales et al., 2005; Gonzalez et al., 2007). Some in the Army leadership have envisioned an entire future force designed around this model (Vick et al., 2002).

The SBCT is a multi-dimensional combined-arms unit with approximately 3,500–5,000 soldiers total. The literature on the SBCT describes it as, “organic,” but the term in the Army context is not meant the same as it has been used in the OMT literature or in this research. By “organic,” the SBCT reports refer to the array of embedded support functions that allow it to conduct a variety of operations (Vick et al., 2002; Gonzales et al., 2005; Gonzalez et al., 2007). These support functions in traditional army units are called in from the division level as part of the Army’s reach back component. Requests for support and expertise can slow deployment and reaction time for most units, which is not so with the SBCT, who generally have such capabilities built into their organizational design. One example of this capability is the presence of an “organic” Reconnaissance-Surveillance-and-Target-Acquisition (RSTA) Squadron. The SBCT also has three infantry battalions, one field artillery battalion, one brigade-support battalion, one antitank company, one engineer company, one signal company and an embedded intelligence company, so they are capable of collecting, analyzing and disseminating a variety of human, signals and other intelligence. The RSTA squadron and intelligence components are greatly assisted by the availability of unmanned aerial vehicles (UAVs), which are an integral part of the SBCT. Human intelligence-trained personnel accompany the reconnaissance function to assist with gathering intelligence from civilians in stability and support operations. These combined reconnaissance and intelligence capabilities are critical in complex environments in which close tactical combat is unfolding and adversaries include terrorists and insurgents who conceal themselves among the local population. The latter is one of many examples where the SBCT’s embedded units, cross-trained personnel, and mixed mission capability make it a virtually self-contained unit, which is atypical of Army units at the brigade level and the reason they can sustain over a longer time duration. The SBCT differ from the traditional Light Infantry Brigade with additional personnel, more diverse capabilities and advance communications technology (Gonzales et al., 2005; Gonzalez et al., 2007; Association of the United States Army, 2006).

The digital network communications capabilities are central to the SBCT's design and give the unit a distinct advantage over comparable units when operating in dynamic environments. The Stryker brigade's innovative organizational structure, digital communications network and "organic" support units are part of new conceptual framework called, "Network-Centric Operations" (NCO). The Army developed this conceptual framework and accompanying doctrine, incorporated as a part of the SBCT ideology, which has changed the way the Army fights in some combat environments. The use of the SBCT in NCO offers the ability to conduct simultaneous offensive, defensive, and stability and support operations with the SBCT in greatly expanded geographical area of operations. The literature calls this "Full Spectrum Operations" (Gonzales et al., 2005; Nardulli, 2003, p. 48; Association of the United States Army, 2006, pp. 4–8).

The SBCT's flexible design and concept of operation allow it to be organized structurally as a hierarchy, but in unstable, dynamic and complex environments, it operates more organically. Depending on the environment, field commanders may choose to follow predesigned and detailed orders based on centralized execution in accord with a specific concept, or in the alternative, may elect to utilize orders that support a decentralized execution in accord with the commander's intent. This more decentralized approach provides a clear description of command intent and mission objectives, but with less detailed descriptions of the methods to achieve those objectives, and thus, can be prepared more quickly. Decentralization supports the SBCT motto of "See First, Understand First, Act First, and Finish Decisively." SBCT doctrine provides multiple options for command methodology and unit synchronization (Gonzales et al., 2005). This flexibility provides a great deal of operational agility, and theoretically, increases effectiveness, particularly in dynamic and complex environments (refer to Figure 4).

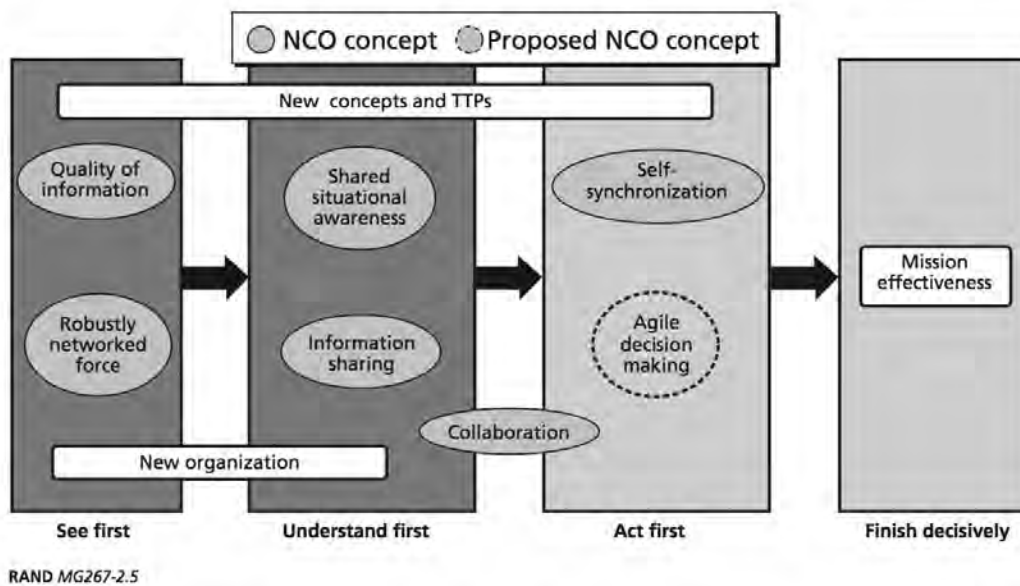
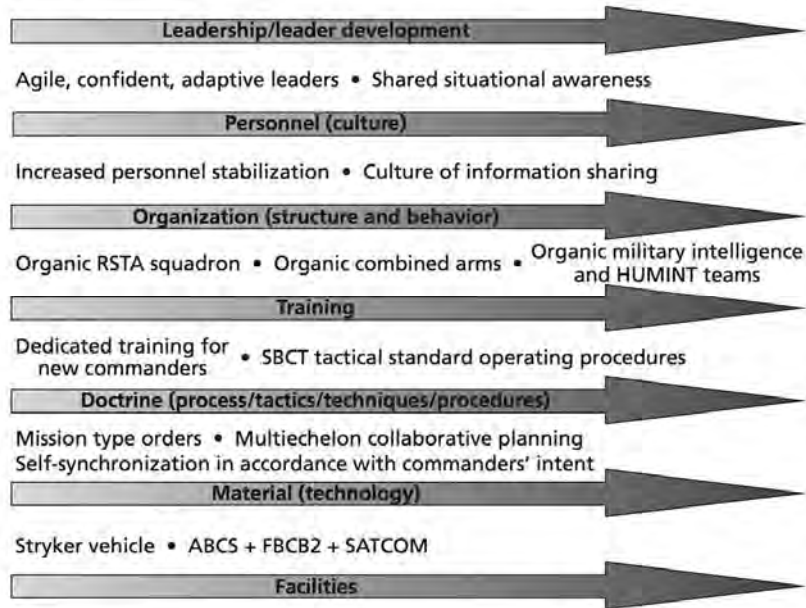

Figure 4. Network-Centric Operations Concept/Stryker Brigade Combat Team Organizational Doctrine (From: Rand Corporation, 2005)

During both case studies involving the SBCT—Certification Exercise (CERTEX) and the stability operations in Northern Iraq—the brigade is presumed to be operating in a model closer to organic than mechanistic on the continuum. These organic aspects of their design were investigated in this research to determine how they contributed to effectiveness.

### Stryker Brigade Combat Team Lines of Development



RAND MG267-3.6

Figure 5. Stryker Brigade Combat Team Lines of Development (From: Rand Corporation, 2005)

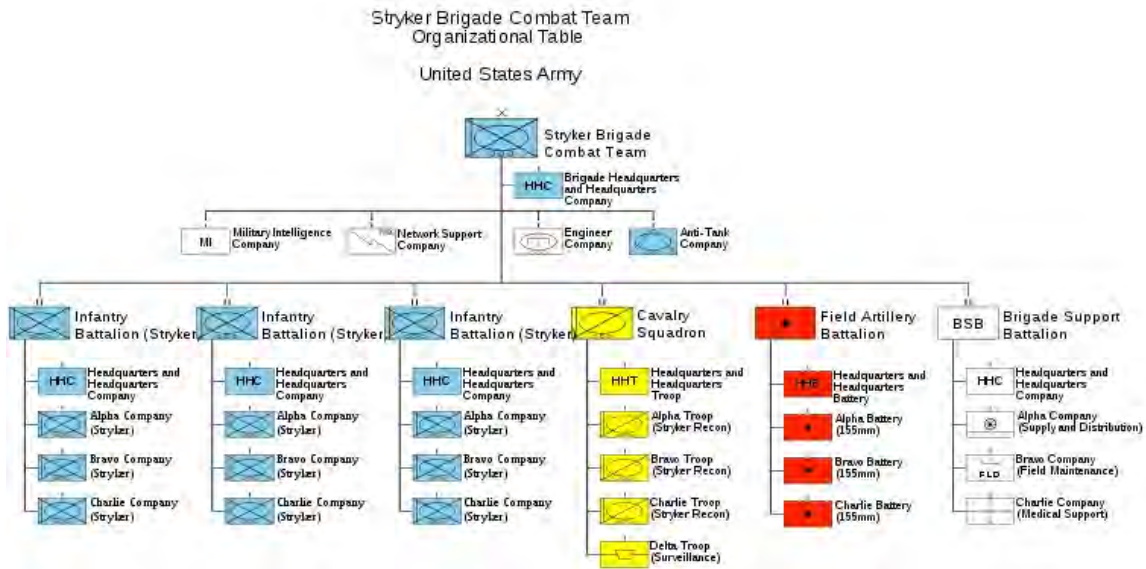

Figure 6. Stryker Brigade Combat Team Organizational Table (From: Wikipedia, 2008)



#### 4. 101st Airborne Division-U.S. Army (101st)

The 101st Airborne Division (101st ABD) of the U.S. Army is organized as a hierarchy with a distinct chain-of-command and comprised of approximately 17,000 soldiers. The 101st ABD includes three infantry brigades, one artillery brigade, two aviation brigades (one assault and one support), a sustainment brigade, an air defense battery, a battalion and a company of military police, and an engineering battalion. During the stability operations in Northern Iraq, the 101st ABD had more than 100 UH-60 Black Hawk helicopters available, whereas the SBCT had only ten. The 101st ABD has more than three times the number of personnel assigned than the SBCT. Based on their size and the number of embedded support personnel typical of division level heavy forces, the 101st ABD are ideally organized for stability operations in a large geographic region like Northern Iraq. The 101st ABD makes a better comparison unit for the SBCT than a light infantry brigade in spite of the apparent size mismatch (Gonzalez et al., 2007).

Based on the visual depiction of the organizational structure and its processes during the stability operations in Northern Iraq, the 101st ABD was presumed to have an organizational orientation toward the mechanistic end of the continuum.

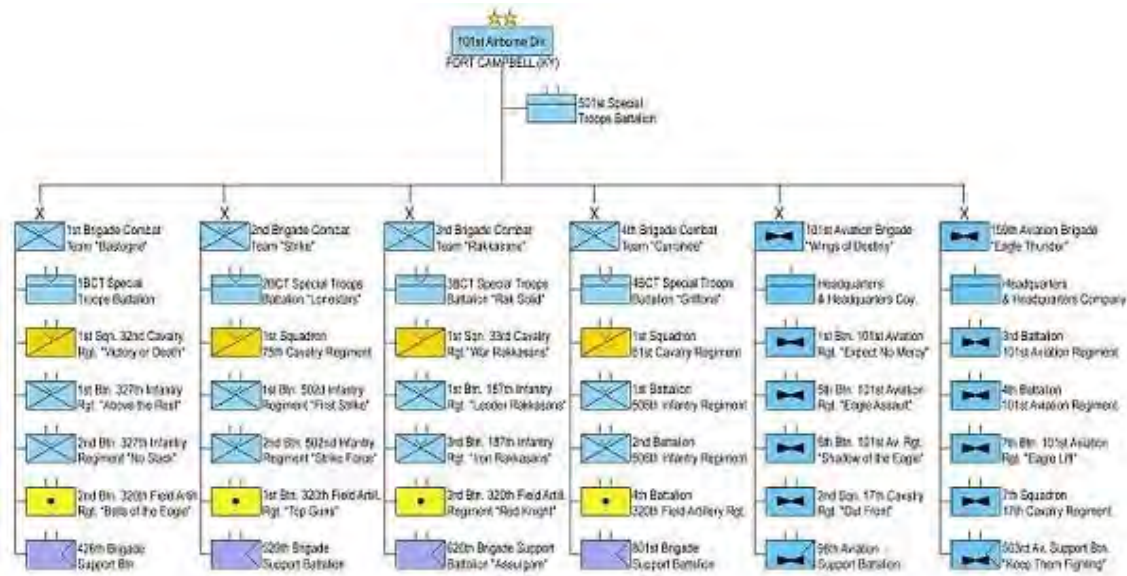

Figure 7. The 101st Airborne Division Organizational Structure (From: <http://www.militaryphotos.net>, 2008)

## **B. CASE STUDIES-THE SCENARIOS**

### **1. Operation Talavera-Training Exercise—2004**

In 2004, the Los Angeles County Operational Area conducted a training exercise—“Operation Talavera”—that included that participation of federal, state, county and municipal response agencies, and the Los Angeles Terrorism Early Warning Group (TEW), with its network of Terrorism Liaison Officers (TLO). The exercise involved the theft of radioactive materials and a series of suspicious activities by terrorist groups throughout the summer, culminating in the December explosion at the Great Western Forum sports venue in Inglewood, California.

During the first phase of the exercise—the pre-incident prevention—the TEW collected, analyzed and disseminated intelligence related to the theft of radioactive materials and indications of a potential terrorist attack. During the second phase of the exercise—the incident—the response agencies managed the complexities of the explosion and its aftermath. The TEW provided intelligence support for the response. The first responders were organized into a unified command within the framework of incident command systems, which included an operations section under the joint command of two section chiefs, a police lieutenant and an assistant fire chief, which was a hierarchical design with a distinct chain-of-command. The second phase—the incident—of Operation Talavera was a full-scale exercise; in other words, it was as close to the real thing as possible. The exercise included real explosions, debris and similar special effects at the actual site—Great Western Forum in Inglewood. Approximately 150 role players (simulated victims) exhibited a variety of injuries and were subjected to actual decontamination procedures. Responder personnel were on-site, dressed in realistic attire and performing the actual duties they would be in a real event. The exercise was conducted mostly in real time, although some time compression occurred as the scenario unfolded throughout the day.

This case study was important for two reasons. First, it offered an opportunity to observe how an organic organization—the TEW—performed in an unstable, dynamic and complex environment; and second, it provided a comparison of organizational

performance between an organic—TEW—and a mechanistic organization—the operations section. The case was examined to determine if the TEW was effective and how their organic design contributed to that effectiveness. Basic assumptions established from a synthesis of the literature supported a prediction that the TEW would outperform the operations section in this unstable and complex environment. This research examined why the organic organization outperformed the mechanistic one, and what design elements of each contributed to or degraded organizational effectiveness. In other words, how did the TEW maximize its effectiveness and how did the Operations Section handicap theirs?

The scenario started with the TEW collecting and analyzing open source intelligence and classified reports indicating increased activity by the terrorist group called Lashkar-e-Toiba (LeT). This South Asian group traditionally focused on the Kashmir region of India and Pakistan, but the TEW sources suggested that LeT was directing its attention to the presence of the U.S. military in Afghanistan, which was putting pressure on the Taliban and al-Qaeda. LeT was particularly distressed by the erosion of one of its primary funding sources—the revenues derived from the opium poppy fields in Afghanistan.

LeT had attempted to organize a meeting with representatives from al-Qaeda, HAMAS and Hezbollah, in an effort to create a collaborative terror network to attack the continental United States. The LeT leader, Mohammed Latif, was attempting to leverage his connection with an Islamic scientist in India's nuclear program. It was suspected that the goal was to construct a Radiological Dispersal Device (RDD)—a traditional explosive laden with radioactive material that disperses into the atmosphere during the kinetic energy release of the explosion.

The TEW monitored a report from the San Diego Police Department regarding the theft of a “blood irradiator” from a local hospital. Hospital officials confirmed the theft of the equipment from a wing of the hospital undergoing renovation. This device contained radioactive material—5,000 curies of Cesium-137. The FBI joined the investigation and began a sweep of the city, using a joint task force of local, state and federal agencies.

The FBI conducted a raid on an industrial warehouse in Irvine, California. They seized a collection of bomb making material. During the search of the warehouse, dismantled parts of a blood irradiator were found. Two individuals using false identification had rented the warehouse one week before the FBI raid. Witnesses saw a large van leaving the warehouse the day prior to the raid. At this stage of the intelligence analysis, TEW members estimated that the construction of a radiological dispersal device (RDD) had been completed.

Throughout the pre-incident phase of the exercise, the TEW made constant use of the TLOs to collect information from other agencies and to disseminate intelligence back to those agencies. TEW used liaisons from the FBI and other federal agencies in the exercise to ensure that information flowed quickly and efficiently. The decentralized design of TEW reduced the possibility of information bottlenecks, which resulted in the group's rapid acquisition of situational awareness. The after action report said, "during the exercise, the TEW and its members performed exceptionally well. Within a short period of time, the TEW was able to establish a threat picture based on less than obvious indications of a developing threat." The use of liaison devices (Mintzberg, 1979, pp. 161–162) was a central feature of the TEW design during the exercise. This use of liaisons enhanced the distribution of information among TEW members and to the other agencies in the exercise, particularly the FBI. The use of the TLO network was one of the primary components of the distribution of information.

The second stage of the scenario involved the detonation of a RDD at the Great Western Forum sports arena in Inglewood, California. The target of the attack was an event organized to honor military personnel who had served in Afghanistan and Iraq, which was attended by several thousand people. The resulting explosion caused significant structural damage to the facility, killed and injured hundreds of attendees, and dispersed a plume of radiation into the atmosphere. This led to a panicked evacuation of the venue and a host of complex and dynamic challenges for first responders. The first recognition of the radiation threat occurred when responding firefighters began to notice their dosimeters sounding alarms.

The responder agencies organized a command post near the site and established a unified command. The primary agencies were police, fire and emergency medical personnel. The objectives were to stabilize the site, restrict access to and from the blast zone, decontaminate and treat survivors for any injuries, evacuate the site and forecast where the radioactive plume would move.

In addition to the challenges of mass care and shelter for the injured and evacuated survivors, and the threat of radiation to the surrounding community, one of the primary challenges was to deal with the level of panic among the survivors. Many of them wanted to leave the site, but responders could not allow them to leave prior to decontamination. The crowd control group consisting of members of the Area G South Bay Mobile Field Force Platoon was assigned to the mass decontamination zone to keep order and move people through the decontamination stations. They were organized into squads under the command of a lieutenant and squad leaders (sergeants). These personnel were operating in class C personal protective equipment (PPE), including Tyvek suits over their uniforms and respirator masks. They were also wearing riot helmets and carrying riot shields. The conditions were difficult because the personnel were hot and had difficulty breathing while wearing the masks. The physical demands of crowd control, and the difficulties imposed by the PPE and riot attire caused personnel to fatigue very quickly. These conditions required frequent and continuous rotation of personnel, and on-scene personnel could not leave their posts until relieved by incoming fresh replacements. Due to the hierarchical design of the organization and the chain-of-command, requests for rotation had to be communicated from the squad leaders to the group leader, through the branch commanders, and passed onto the operations section chief, who in turn, alerted the staging manager to send the necessary resources. The group leaders were not given the decision authority to issue such an order and the interaction between unified command elements had to go through the centralized leadership structure (section chiefs). The disadvantage of this design became apparent when the section chiefs became overwhelmed with requests and information, and a significant delay occurred in replacements being sent to the site. A similar breakdown in communication occurred when one group failed to alert another of structural concerns in

the facility. Since the information had to go through the chain-of-command, the rescue teams were not given the information in a timely manner, which resulted in the loss of responder personnel in a partial collapse of the structure.

The inability of individual units to interact with each other and the requirement of passing information through a central command caused information lag, and in some cases, distortion of information. The restricted decision authority among field commanders degraded their ability to make sensible decisions in the face of changing conditions without seeking approval from the command post. In the context of the unstable, dynamic and complex environment during the exercise, the organizational design of the operations section degraded its ability to meet its objectives.

The TEW was tasked with support of the response efforts, including frequent updates to contribute to situational awareness and estimates for how the scenario would unfold (net assessment). They effectively provided timely and actionable intelligence to all responder agencies. Their primary tool at the command post was the use of the TLOs to communicate new information. They did not operate with any information sharing restrictions. Each of the TEW cells was allowed to communicate directly with any other cell. The A/S cell collated and analyzed incoming information to ensure nothing was missed and the OIC cell ensured that the cells were coordinating with each other. This coordination became critical when one of the TLOs became aware of a crowd control problem at a local hospital where contaminated survivors of the explosion had walked into the emergency room. The TEW network quickly alerted the responder agencies and a group was tasked with security and decontamination in the hospital parking lot. Numerous examples occurred throughout the exercise of TEW or TLO personnel relaying critical information to responder agencies so that information could be quickly converted into action. The decentralized design, unrestricted communication and the use of liaisons contributed to the TEW effectiveness and ensured their exercise objectives were achieved.

The after action report read, “the exercise emphasized all-source intelligence collection and fusion in support of multiple allied law enforcement agencies working informants, tips and leads. Additionally, because the TEW is uniquely

structured...information was also collected through non-law enforcement channels, adding to the depth and robustness of the analysis. The “structure” was a network, in which the patterns of interaction were unconstrained and the distribution of information was broad throughout the exercise.

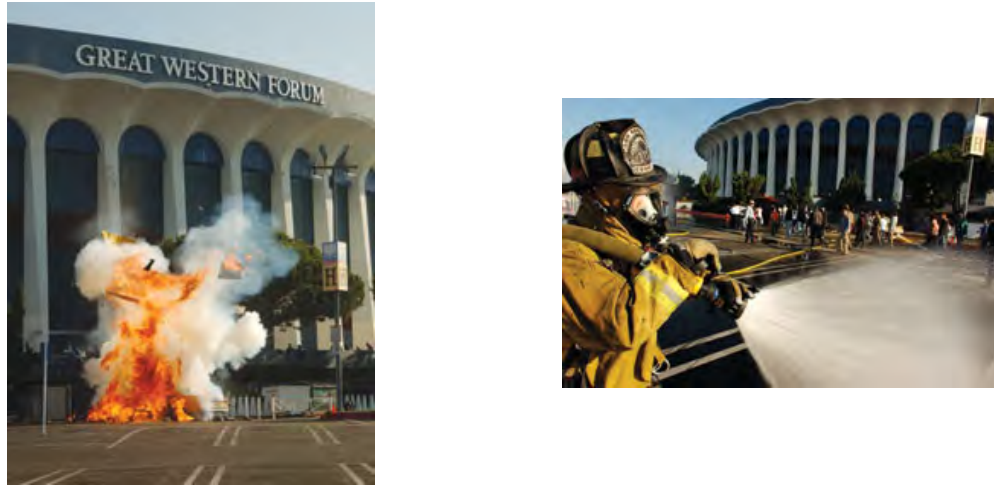

Figure 8. Operation Talavera Images (From: IAFC *On Scene*, 2005)



Figure 9. Operation Talavera Images (From: <http://uuu.mindtel.com>, 2011)

## 2. Operation Chimera-Training Exercise—2005

In August 2005, the Los Angeles County Operational Area conducted a training exercise —“Operation Chimera” that included that participation of federal, state county and municipal response agencies, which included the Los Angeles Terrorism Early Warning Group (TEW) and its network of Terrorism Liaison Officers (TLO). The

exercise involved a biological (anthrax) attack by a terrorist group (al-Qaeda), a narrative that in theory was designed to unfold over a period of months as people began to report flu-like illness, but eventually would be linked to anthrax exposure. The concurrent counterterrorism investigations by other agencies over time intersected with the reported infections, but the complete picture of what was happening was unclear to TEW members attempting to uncover and connect information sources to acquire situational awareness. This situation was the intended reality the exercise was designed to replicate, but the participants were actually gathered together during a single day to conduct the exercise. The compressed time scale, during which hours could represent days or weeks, presented some artificiality, but the sequence of events and desired responses were designed to be as realistic as possible.

This case study provided further opportunity to observe how an organic organization—the TEW—performed in an unstable, dynamic and complex environment. The case was examined to determine if the TEW was effective, and why and how their organic design contributed to that effectiveness.

The scenario involved the aerosolized release of anthrax (*Bacillus Anthracis*) in the greater metropolitan area of Los Angeles, California, which was ultimately established to be a terrorist attack. Various parts of the scenario were given to TEW members at different times during the exercise.

In the early stages of the scenario, it was reported that intelligence summaries had documented communications between Osama bin Laden and Abu Musab al-Zarqawi. The substance of the communications was unknown, but the messages between the two terrorist leaders had increased in number and frequency. It was suspected that bin Laden wanted Zarqawi to focus his attack planning outside of Iraq and possibly within the United States, which was seen a significant shift in strategy.

At approximately the same time that intelligence officials were becoming concerned about the trend in al-Qaeda communications, the Centers for Disease Control and Prevention (CDC) began to notice an increase in reports of the flu in the Los Angeles County operational area, which had risen to exceed the annual national average. The



Public Health Officer for Los Angeles County requested that all LA area hospitals and clinics report any patients complaining of flu-like symptoms through the county's computerized reporting system (REDDINET). The health department was seeking to understand better the reasons for the statistical anomaly in their region.

Within this timeframe, the FBI issued an alert to law enforcement agencies that it was investigating a connection between the Mara Salvatrucha gang (MS-13) and radical "Arab" or "Muslim" groups seeking to use established narcotics smuggling routes.

The New Orleans Health Department reported that three longshoremen had contact with a sheep contaminated with anthrax spores and all three were eventually admitted to a local hospital with flu-like symptoms, where one of the men ultimately died. Anthrax exposure was listed as the cause of death. As the New Orleans incident came to light, laboratory results in Los Angeles confirmed several cases of the "flu" actually tested positive for *Bacillus Anthracis*, the bacteria commonly known as anthrax.

As FBI investigators discovered the possible source of the anthrax, which was a tampered shipping container in the Port of New Orleans that contained Russian made, weaponized anthrax, al-Qaeda terrorist and American citizen Adam Gadahan (aka Azzam the American) was taken into custody in San Diego, but immediately died from anthrax exposure. As the anthrax threat became clearer, a safe house in London was raided and evidence was seized that revealed a possible plot against U.S. rail transportation.

The TEW had to work collaboratively with public health officials both at the federal and local level to monitor the number and location of cases. The objectives were to detect the existence and extent of the attack, develop situational awareness, forecast how the attack would unfold and develop strategic counter-measures.

As the scenario unfolded, the TEW collected and disseminated information with liaisons at the health department and among the public safety agencies they represent. Members of the TEW's epidemiological team (epi-intel cell) collected enough information from public health officials to suspect a biological attack, which was done rapidly through their "syndromic surveillance capabilities." Once the illnesses were

suspected to be an attack, the TEW made a several design changes that are indicative of the TEW philosophy, but atypical of traditional response organizations—where the design is generally oriented more towards the mechanistic end of the continuum.

First, the epi-intel cell lead, who was a bioterrorism expert, embedded as a direct liaison to the Public Health Technical Advisory Group (TAG), which was a cross-section of federal officials organized by the U.S. Department of Homeland Security. This allowed information to move horizontally across agency lines. At the same time, the TLOs were already disseminating information horizontally to their respective agencies. This use of liaison devices optimized the speed and accuracy of necessary information. The use of liaison devices positively influenced the pattern of interaction among organizational members and across organizational lines, but also broadened the distribution of information necessary to perform effectively, which related directly to the literature (Mintzberg, 1979, pp. 431–467; Alberts & Nissen, 2009).

Second, the TEW fully integrated the epi-intel cell into the analysis/synthesis (A/S) cell, which is the TEW's team for collating and analyzing incoming information from all sources. It would have been unthinkable for most responder agencies with a more mechanistic orientation simply to fold one organizational sub-unit into another for situational reasons, but the TEW philosophy allows for any of its teams (cells) to combine with any other cell. This flexibility of form can be related to the literature as a key strength of organic organizations (Galbraith, 1973; Alberts & Hayes, 2003; Alberts & Nissen, 2009).

Third, the epi-intel cell took the lead role in the exercise since it was determined to be an epidemiological threat it was confronting. The epi-intel cell would set the tempo and direct resources throughout the remainder of the exercise. Since the epi-intel cell is not normally the lead cell, this change of form demonstrated emergent leadership, which is another characteristic of organic designs described in the literature (Alerts & Hayes, 2003; Alberts & Nissen, 2009).

This flexibility of form, use of liaison devices and emergent leadership contributed to the unconstrained pattern of member interaction, decentralized decision authority, and broad distribution of information; and therefore, to the overall effectiveness of the TEW, who achieved the exercise objectives.

### **3. Democratic National Convention—August 2000**

Between August 14 and August 17, 2000, the City of Los Angeles hosted the Democratic National Convention (DNC) at the Staple Center in downtown, immediately after the City of Long Beach, CA had finished hosting the Reform Party Convention August 10–13 at the Long Beach Convention Center. These major political events presented public safety and security challenges in the Los Angeles region that required a massive intelligence effort. The larger of the two events (DNC) was designated a National Security Special Event (NSSE), which is an event identified by the Department of Homeland Security to be of such a significance that it could be a likely target for a terrorist attack. The NSSE status is based on the anticipated attendance of dignitaries, the size of the event, and the political or cultural significance of the event. Part of the large response for both events included the activation of the Los Angeles County Operational Area Emergency Operations Center (CEOC) and the Los Angeles County Sheriff's Department Operations Center (DOC), both of which were responsible for coordination of county resources. The Los Angeles Terrorism Early Warning Group (TEW) and its TLO network were assigned to provide intelligence support to the CEOC and the DOC, which included pre-event planning, trans-event response and assessment, and post-event recovery.

Although other intelligence organizations were part of the operational deployment for the DNC, this research examined the TEW because of its organic design. This case study provided an opportunity to observe how an organic organization—the TEW—performed in an unstable, dynamic and complex environment; in this case, a real operation conducted in real time. The case was investigated to determine if the TEW was effective and how their organic design contributed to that effectiveness.

The DNC presented serious security concerns including the possibility of terrorist attacks and the near certainty of civil protest groups. The TEW's primary concern was the possibility that interest groups representing causes ranging from human rights, labor, globalization and trade to animal rights, environmental rights, abortion rights and anti-police would stage protests or conduct civil disobedience operations. In particular, the anarchists had made public pronouncements that they would engage in what they called "direct action" operations, where violent and unlawful activities aimed at disruption of the event would be conducted. Groups known as "black blocs" were of great concern. The TEW had collected intelligence from prior events in other cities at which "black blocs" had used such tactics, including the Washington D.C. World Bank meetings and the Seattle World Trade Organization event, during which rioting had resulted. The TEW was tasked with maintaining situational awareness, collection and dissemination of intelligence, and conducting a net assessment to forecast upcoming issues to develop countermeasures where possible.

Early in the operation, the TEW made use of liaisons by embedding members of their teams into other operational units among responder agencies and inviting corresponding members of those units into the TEW structure, which included the FBI and Los Angeles Police Department. These liaisons were in addition to the cadre of TLOs that represent the individual agencies that contribute to the TEW. This liaison concept had immediate results. On August 14, reports began to surface that protest groups were becoming cohesive and were "practicing" the use of mass movement for effect. Several of the groups were seen rehearsing these pre-designed movements. They were also employing the use of radio scanners to monitor police frequencies, and thereby, anticipate and evade enforcement action. The functional TEW team in charge of analysis and synthesis (A/S cell) began to analyze such reports quickly with an emphasis on predicting future movements by the groups, followed by rapid dissemination to field units. One early incident occurred when a group at Hill and 6th Streets surrounded a LAPD squad. This incident and others were analyzed to discern and disseminate tactics. Other field units were quickly alerted to the almost ubiquitous presence of demonstrators' backpacks

that contained gas masks, lighter fluid and spray cans. This forewarning resulted in mass arrests of backpackers in possession of those items. The use of liaisons ensured the rapid and broad dissemination of these critical details.

The rapid collection, analysis and dissemination of such intelligence armed field units with information related to tactics like linking arms, the use of super glue on fingers, and other disruptive practices. This knowledge also led to the anticipation of protestor movements including a planned protest at police stations and custody facilities. Much of this information was collected on August 15 and disseminated in time to anticipate marches at the Rampart Police Station and Parker Center on the morning of August 16. Liaison devices and decentralized dissemination through the TLO network predicted protestor tactics and movements and converted intelligence into law enforcement action with minimal delay. By the morning of August 17, the TEW was receiving reports that protestors were becoming frustrated at their lack of effective resistance.

The TEW met the operational objectives using broadly distributed information dissemination, liaison devices and networked teams. This information dissemination mode is indicative of organic design and it alerted field units to necessary information that improved field tactics and safety for the responders.

#### **4. Certification Exercise-Stryker Brigade Combat Team 2003**

In May 2003, the U.S. Army Stryker Brigade Combat Team (SBCT) participated in a certification training exercise (CERTEX) at the Joint Readiness Training Center (JRTC) at Fort Polk, Louisiana. This training exercise was set on the fictional island of Aragon in and around the fictional town of Shughart-Gordon. The SBCT was directed to meet three simultaneous mission objectives.

1. Attack and defeat an enemy force that had time to establish defensive positions
2. Defend against an enemy attack in another geographical sector from the offensive mission
3. Conduct a stability and support operation to assist and protect the local civil authorities

Prior to this particular exercise at the JRTC, no light infantry or mechanized brigades had ever been expected to conduct this combination of complex operations simultaneously. The difficulty of the exercise did not favor success for the SBCT. In fact, it was anticipated that the best outcome for the SBCT would be mutual destruction. In the search for case studies that best exemplified unstable, dynamic, and complex environments, few could have had a better fit than CERTEX.

This case study, taken from secondary source material by the Rand National Defense Research Institute, *Network-Centric Operations Case Study: The Stryker Brigade Combat Team* (Gonzales et al., 2005), was selected because it offered an opportunity to observe how an organization—the SBCT—functioned organically in an unstable, dynamic and complex environment even though its organizational structure was visually depicted as a hierarchy on the organizational chart. The SBCT demonstrated organizational flexibility that became evident in this case, and this flexibility enhanced its performance. The CERTEX case study provided some key indications as to why and how organic organizational designs perform well in unstable, dynamic and complex environments.

The scenario occurred in an exercise zone 50-kilometers by 50-kilometers in total area. The action began with an enemy force comprised of personnel numbering at the tactical brigade level, traveling south and moving into position to mount an attack on elements of the SBCT. Simultaneously, a group of insurgent fighters about the size of three companies, assumed to number approximately 450 enemy combatants, formed defensive positions along the roads leading into the town of Shughart-Gordon. An additional group of enemy specialists was conducting raids in various locations in the operational area against “friendly forces” and a forward operating airbase. The complexity of the exercise was compounded by the densely forested battle terrain, with a mix of urban areas, and the SBCT also had to contend with the presence of innocent civilians, criminal elements, members of the media and non-governmental organizations present in the battlespace.

The enemy forces were simultaneously defending a 15-kilometer-wide disruption zone east of Shughart-Gordon, attacking friendly reconnaissance elements, denying

avenues of approach, and inflicting personnel attrition on friendly forces. The enemy forces had a significant amount of time to prepare defensive positions in the urban terrain, using barbed wire and mines. They had also established firebases that could provide direct and indirect fire on forces attempting to advance on the defended positions.

The SBCT mission was to attack, seize and control the defended enemy positions, while restoring the political control and stability of the town of Shughart-Gordon. The brigade commander's concept of operation was based on gaining and exploiting the information advantage, and using that information to maintain offensive momentum.

In the interest of transparency, it is important to highlight the three main advantages that the SBCT has over traditional light infantry brigades. It possesses advanced digital communications capabilities (pursuant to the doctrine of network-centric operations) including live video conferencing. It also possesses fast-moving armored vehicles that can deliver soldiers to the attack zones without fatiguing them by marching them on foot; and the SBCT uses a non-traditional organizational design that includes organic design principles. The Rand case study focused on the digital technology component as a variable for measuring effective performance, but the study conceded it was impossible to separate the various advantages to measure any one of them. This research took the Rand data to observe the organizational design features and their contributions to unit effectiveness, but like the Rand study, it was impossible to completely determine how much of the SBCT's total performance was due to the technology, the use of the Stryker vehicle, or the organic design.

Early in the attack planning, the SBCT commanders conducted a series of multi-echelon planning meetings to synchronize the forces and unify their understanding of the battlefield. These planning meetings were conducted via digital video teleconferencing and allowed commanders to be forward with their troops, yet able to confer with their peers and superiors. From an organizational design framework, the planning meetings demonstrated organic orientation in several ways. They stressed multi-lateral, peer-to-peer communications, which simultaneously supported unconstrained patterns of interaction and broadened the distribution of information. The meetings expedited the acquisition of shared situational awareness, or what SBCT commanders referred to as

“Common Operating Picture” (COP), which ultimately contributed to the self-synchronization of the SBCT subunits. These concepts also contributed to improved operational performance by allowing the SBCT to move quickly and press the battle more aggressively. Many of these concepts related directly to the literature on organic organizational design (Mintzberg, 1979; Alberts & Hayes, 2003; Alberts & Nissen, 2009).

One of the mission objectives was to attack, seize and control the enemy’s defensive positions, and ultimately, seize control of Shughart-Gordon by 0600 hours on May 25. The battle plan called for an attack at 0400 hours, two hours ahead of the objective target time. One of the “organic” RSTA squadrons was given the assignment to conduct reconnaissance of and collect intelligence on the routes into the town. The intended objective of this reconnaissance/intelligence mission was to obtain information necessary to support a decision whether to attack the town from the north or south. The information was so timely and accurate in depicting enemy force location and strength that the entire battle plan was adapted around this changing variable. Since the SBCT routinely provided its commanders with the decision authority to follow the original plan or adapt within the mission intent to new information, the commander made two key decisions. He decided to maneuver his forces to bypass 66% of the enemy’s force strength and attack their weakest point; and he accelerated the attack schedule by 13 hours, and launched the attack at 1500 hours on May 24. The tactical maneuver and accelerated timeframe caught the enemy force by surprise and proved to be the decisive battle of the exercise. The keys to the SBCT success included the following.

- Decentralized decision authority allocated to subordinate commanders
- Broad distribution of information among SBCT personnel
- Unrestrained patterns of interaction allowing for peer-to-peer communication

SBCT commanders used the updated information to change the battle plan and move their forces earlier and in a different direction than originally planned. This adaptation was made possible because of the information advantage achieved by the RSTA squadron through a mixture of technological data and human intelligence (HUMINT). The advanced digital technology utilized by the SBCT thus became an



inextricable element in its organizational design. The technology established links between the layers of command and among various subunits of the SBCT, which served as a liaison device to broaden both peer-to-peer interaction and distribution of information. Decentralized decision authority, peer-to-peer interaction, and broad distribution of information are key concepts in the OMT literature related to organic organizational forms (Mintzberg, 1979; Alberts & Hayes, 2003; Alberts & Nissen, 2009). The literature supports the concept that information richness and accuracy are enhanced by peer-to-peer interaction, and the broad dissemination of information (Mintzberg, 1979; Alberts & Hayes, 2003; Alberts & Nissen, 2009). The Rand report expressly measured the information quality and accuracy as variables. Baseline units typically rated the quality and accuracy of information received during the exercise at about 20%, based on post exercise interviews; that quality and accuracy rating soared to 90% among participants interviewed from the SBCT (Gonzales et al., 2005). The digital technology contributed heavily to this finding. The complexity of the environment offered opportunities that could be exploited by the technology, which became an element of the SBCT's organizational design.

The Rand report (2005) read, “the SBCT demonstrated improved speed of command, creating better decision options, self-synchronization, force agility, mission success, and survivability” (p. 93). Since the Army ran these exercises routinely, it had established some baseline performance measurements for brigade level units in the past. The report indicated that the SBCT performance exceeded the baseline standard in nearly every measureable category (pp. 61–99). Ninety-five percent of the SBCT soldiers interviewed by Rand had confidence in the unit's ability to accomplish its mission (p. 98).

The organic design features that contributed to performance included peer-to-peer communication, shared situation awareness, and broad distribution of information with multi-echelon meetings, and improved flexibility and agility using decentralized decision authority. The superior performance of the SBCT exemplified their motto of, “see first, understand first, act first, and finish decisively.”

## Command and Synchronization Options

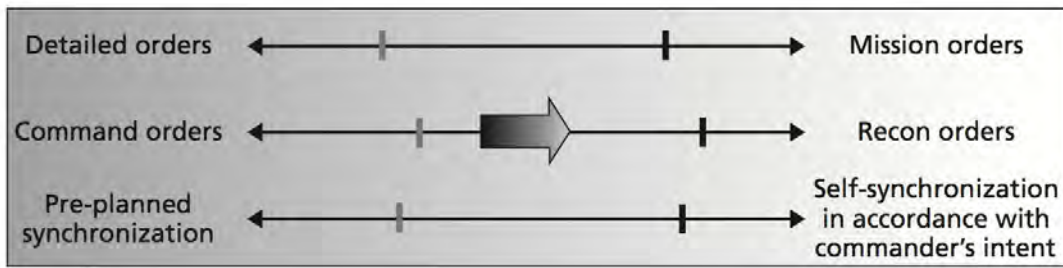

RAND MG267-3.5

Figure 10. NCO/SBCT Command and Synchronization Options (From: Rand Corporation, 2005)

### 5. Northern Iraq-Stryker Brigade Combat Teams 2003–2005

In the case study of the 2003 SBCT CERTEX, the Rand report (2005) characterized the Stryker brigade as agile, adaptive, responsive, innovative and capable of operating effectively and efficiently in highly uncertain and ambiguous environments. These characteristics and capabilities are consistently associated with the SBCT in a variety of literature (Association of the United States Army, 2006; Toomey, 2004; Vick et al., 2002), and those very same characteristics are consistently correlated with organic design in the OMT literature. The Rand report (2005) also pointed to the decentralized decision authority allocated amongst its corps of subordinate commanders, as a key to enhanced performance. The SBCT doctrine on leadership includes, “...developing agile, adaptive, and confident leaders by blending both analytical and creative ways of thinking and training” (Gonzales et al., 2005, p. 37). These are some of the elements that correlate to organic design and also contributed to the SBCT’s superior performance, but that was training. How would these design elements come into play in actual combat? This question was examined in the following case study of the stability operations in northern Iraq, which was documented in another report by the Rand Corporation. The case presented further opportunity to examine the organizational characteristics of the SBCT, and why and how organic designs perform well in unstable, dynamic and complex environments. The modern battlefield in the asymmetrical age of the “War of Terror” (WOT) offers an ideal environment to examine these questions.

Between 2003 and 2005, three units of the U.S. Army conducted stability and counterinsurgency operations in the provinces of northern Iraq.

- 3rd Stryker Brigade Combat Team of the 2nd Infantry Division (3/2 SBCT)
- 1st Stryker Brigade Combat Team of the 25th Infantry Division (1/25 SBCT)
- 101st Airborne Division (101st ABD)

The stability and counterinsurgency operations examined for this case study had two primary mission objectives.

1. Stabilize the political environment to support Iraqi national democratic governance
2. Defeat terrorist and insurgent groups in the area of operation

This case study taken from secondary source material by the Rand National Defense Research Institute, *Networked Forces in Stability Operations: 101st Airborne Division, 3/2 and 1/25 Stryker Brigades in Northern Iraq* (Gonzales et al., 2007) was selected because it offered an opportunity to observe how organizations—the 3/2 and 1/25 SBCTs—functioned organically in an unstable, dynamic and complex environment as compared to a more traditionally mechanistic design—101st ABD.

It should be disclosed that the SBCTs had some advantages over the 101st ABD because of their use of advanced digital communications capabilities (network-centric operations) including live video conferencing. They also used fast-moving and heavier armored vehicles that could deliver soldiers safely to the attack zones without fatiguing them by marching them on foot. The SBCTs also had a non-traditional organizational design that included concepts of organic design. The 101st ABD could only communicate with lower echelon field commanders through analog radio communications and had only lightly armored personnel carriers that were more vulnerable to attack, and therefore, susceptible to casualties. The advantage of digital communications gave the SBCT field commanders a much shorter planning cycle for attack planning and greater agility to redirect resources to change the attack strategy or choice of target (Gonzales et al., pp. 69, 154). Conversely, the 101st ABD had the advantages of a force three times the size of either SBCT and the presence of a significant number of military police personnel who

assisted in supporting civilian policing efforts. This research took the Rand data and investigated the organizational design elements, and how they contributed to unit effectiveness, but it is impossible to determine how much of the total performance differences were due to the technology, the use of the Stryker vehicle, or the organic design of the SBCTs. As with the Rand study, this research remained focused on the Stryker brigade's performance in stability operations. The inclusion of the 101st ABD's performance was only to establish a baseline comparison.

The area of operations included Ninawah, Dahuk, Arbil, and As-Sulaymaniyah provinces, which comprised a total area of nearly 64,000 square kilometers, and included the two largest cities in northern Iraq, Mosul and Tal Afar. The estimated total population for the entire operational area was six million inhabitants, but this research focused primarily on combat engagements in Ninawah province with a population of 2.5 million inhabitants. Mosul and Tal Afar are located in this area and it is the only province in which all three units (101st ABD, 3/2 SBCT, and 1/25 SBCT) consistently operated, although at different times. Both cities were considered to be located at the northern end of what was characterized as the "Sunni Triangle," a region thought to be the heart of the insurgency. The cities in the "Sunni Triangle" particularly susceptible to violence had multiethnic populations, which added to the complexity of the SBCT's operational environment. Mosul and Tal Afar were counted among those cities that fit that multiethnic profile. During the operations of the 101st ABD, 3/2 SBCT and the 1/25 SBCT, those forces had to confront a combination of indigenous insurgents and foreign terrorist groups—both adapted to U.S. tactics over time. The SBCTs and other U.S. military units were assigned to stabilize the region, restore critical services, and help to rebuild government institutions.



Figure 11. Map of the provinces of Northern Iraq (From: Rand Corporation, 2007)

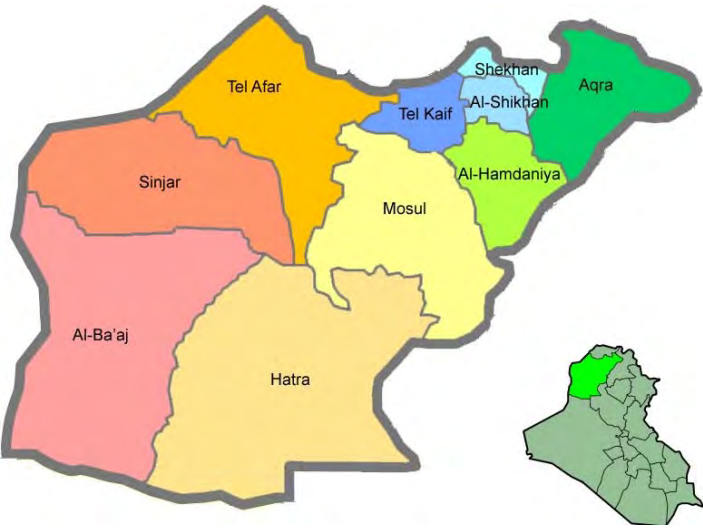

Figure 12. Map of Ninawa Province Iraq (From: Rand Corporation, 2007)

The 101st ABD served in northern Iraq through the major engagements of the war until November 2003, when the 3/2 SBCT was deployed as their replacements in some provinces, although their presence did overlap. By January 2004, the 3/2 SBCT moved into the north to replace the 101st ABD fully. The 1/25 SBCT arrived in northern Iraq in October 2004 and remained through 2005.

During the deployment periods of both SBCTs, their performance was rated as highly effective (Gonzales et al., 2007), and the findings from the CERTEX case study were supported again in this environment in that the SBCTs showed greater agility, adaptability and innovation than the 101st ABD as outlined by the Rand report. One such example of the SBCT characteristics was an incident involving a helicopter crash in the city of Tal Afar in September 2004.

The city of Tal Afar is located in the Ninawah province in northwest Iraq near the Syrian border. A well-traveled highway leading into Iraq from Syria traverses the city. In 2004, when the insurgency began to gain momentum, a significant number of foreign fighters entered the country to join the jihad, and that highway became their common route. Tal Afar was, therefore, ripe for skirmishes between U.S. forces and insurgents. As this was a relatively new phenomenon and intelligence reports in the region were intermittent, only a small presence of the 3/2 SBCT were in the city.

The 3/2 SBCT had begun a series of high-value target (HVT) missions in the city using a battalion-strength task force from its 5th Battalion, 20th Infantry Regiment (5-20 Task Force). High-value target missions are generally efforts to search for and capture or kill insurgent leaders or members critical to the group (Frankel, 2011). The operations in the Ninawah province were collectively known as “Operation Assyrian Drifter,” which began on September 3, 2004. On September 4, the 5-20 task force entered Tal Afar to conduct three simultaneous HVT search operations. The task force was comprised of a Stryker company, scout platoon, and a company of Iraqi National Guard troops, who operated in pick-up trucks without the benefit of the armor protection that the Stryker vehicle offered its soldiers. The scout platoon received its surveillance reports from two OH-58 Kiowa Warrior helicopters and a UAV patrolling overhead.

Initially, the operation was on track, but then at 8:50 a.m., one of the helicopters sustained an RPG hit and went down. The 5-20 task force commanders had to abandon the unfolding operations to address this sudden change of events. The rapid response and retasking of resources would test the SBCT’s organizational characteristics of agility and adaptability. The crash location was immediately verified over the radio by the battalion commander and also through the use of the SBCT’s sophisticated digital computer

network that linked with systems onboard the helicopter. Since the SBCT's digital networking capabilities were so robust and ubiquitous among the various brigade elements, the Stryker vehicles and scout platoon also had the information almost immediately. The scout platoon was at the crash site in less than five minutes and quickly loaded the helicopter crew into the Stryker medical evacuation vehicle.

Unfortunately, the story did not end there. The next three hours would present the 3/2 SBCT with a highly unstable, dynamic and complex environment, and the threat of extensive loss of life. UAV surveillance revealed approximately 60 insurgents moving toward the site. The scout platoon was almost immediately overwhelmed during an intense 20-minute firefight involving a large and growing concentration of insurgents armed with RPGs, machine guns, and variety of other firearms. Outnumbered three to one, the platoon requested reinforcements.

Bravo Company was sent to reinforce the west side of the crash site and assist the scout platoon, but immediately encountered hostile fire from enemy positions. They headed south along the small roads and alleys of the city in an attempt to arrive at the crash site and prevent the scout platoon from being overrun. The twisted route necessary to get there required heading first south, then east, and finally north in a complicated and circuitous maneuver. The challenges faced by Bravo Company were eerily similar to the Battle of Mogadishu during the now famous "Blackhawk Down" incident. As Bravo Company made its way through the maze, the number of insurgents increased, as did the intensity of the incoming fire from the variety of weapons. Insurgents occupied buildings and rooftops, and used high ground positioning to their advantage. One platoon had come to a complete stop, not able to continue under the pressure of such heavy fire. Another platoon had a disabled Stryker vehicle that had been hit with RPG fire.

The Bravo Company commander made several adjustments to his battle plan based on the perceived need to adapt to the changing conditions. He called for close air support and stopped the column's forward progress to reroute the approach. This change allowed the pinned-down platoon time to break free from the insurgent attack and rig the Stryker vehicle for towing. The company finally arrived at the crash site, but the circuitous route and intense fighting to arrive there left them on the eastern edge of the

site instead of the western perimeter where they were needed. They could not cross the open town square to reach the western edge of the site because of insurgent RPG and mortar fire. UAV surveillance revealed 20 additional insurgents entering the combat zone with more RPGs and machine guns.

The battalion commander coordinated with the scout platoon leader to devise a plan so they could secure the entire site perimeter. The battalion commander then requested a Joint Direct Attack-Munitions (JDAM) strike on the enemy positions by an in-bound F-16 aircraft. The Bravo Company commander quickly adapted his plan to account for the impending JDAM strike, which included taking possession of four buildings on the western edge of the crash site immediately after the JDAM blast. The plans of the various leaders had to be adapted to keep pace with the battle tempo and with minimal consultation. The digital connectivity and decision authority given to the company commanders allowed for this agility. Bravo Company's commander was taking full advantage of the SBCT's digital networking capabilities and the SBCT organizational doctrine to maintain his company's momentum against unfavorable and complex conditions, which was the epitome of ambiguous environment.

After the JDAM strike, the lead platoon of Bravo Company maneuvered to the western edge of the crash site, as Bravo soldiers cleared the four pivotal buildings that overlooked the location, which ensured an effective perimeter defense for the site. The flight crew was evacuated, and the helicopter was eventually loaded onto a truck and removed from the site, all of which was accomplished under heavy fire.

At the conclusion of the three-hour battle, 110 insurgents were found dead and it was suspected that they had sustained a significant number of wounded, but this information was not confirmable. No U.S. soldiers were killed and only five were wounded. One Iraqi National Guardsmen was killed and two were wounded.

The Rand report analyzed the performance of the 3/2 SBCT during the battle of Tal Afar to account for its success and minimal casualties. The digital networking capabilities of the SBCT were highlighted as a significant factor in allowing commanders to use real-time information to adapt battle plans and maintain situational awareness. The



report also cited the Bravo Company commander for the decisions made under adverse conditions, the speed of command, and the rapid dissemination of plans to company personnel. The scout platoon's rapid movement to the crash site initially was also listed as critical. Company commanders were praised for deploying necessary resources and executing plans "...despite not explicitly being told what equipment to bring and what to do at the crash site" (p. 89).

As in the CERTEX case study, the SBCT's organizational doctrine of decentralized decision authority, peer-to-peer interaction and broad distribution of critical information accounted for agility, adaptability and responsiveness, which are hallmarks of organic design. The Rand report listed similar findings throughout the deployment of the 3/2 and the 1/25 SBCT's tour of duty in northern Iraq. Earlier that year (2004), the 3/2 SBCT provided another example of superior agility, adaptability and responsiveness, but not in northern Iraq. The 3/2 SBCT was abruptly called out of its area of operation to support other U.S. forces under attack. During the SBCT deployment period, insurgents had mounted impressive counterattacks against U.S. forces in Najaf and Fallujah, which had to be reinforced.

In April 2004, the 3/2 SBCT had to partially halt operations in the north and send a battalion—again it was the 5th Battalion, 20th Infantry Regiment (5-20)—to Najaf to support the 1st Armored Division. The 3/2 SBCT sent the 5-20 group on a mission that included disengaging from its current combat operations and traveling 600 miles in two days. The agility of the 5-20 was evident because it had just fought in several major battles and had to retask resources to make the journey to Najaf, and it had to reroute several times along the way to respond to the movements of insurgent forces. On April 11, the 5-20 had to stop to deal with an IED attack, and yet it made it to a forward operating base on schedule. The battalion commander used his authority to change the plan and split the force into two separate teams. One team traveled on a western route around and through Baghdad. The other team followed an eastern route and immediately came under attack. It was hit with IEDs, RPGs, and heavy automatic weapons fire at the Tigris River Bridge. Unfortunately, the enemy forces had disabled the bridge, so the team had to adapt and move quickly to secure the bridge at Al Kut. By splitting the battalion

into two teams, the commander ensured that the mission would stay on schedule to get reinforcements to the objective as planned. The tactic worked well and the two teams eventually reunited and secured another bridge at the Euphrates. The 5-20 arrived in Najaf, having traveled over 600 miles in under 48 hours, with only one soldier killed during the journey. The Rand report described the movement of mechanized forces over this huge distance in such a short period of time and with so few losses as, “unprecedented” (p. 73). The report highlighted the digital technology and adaptive nature of the SBCT as significant contributions to its success (p. 73).

The Rand report surveyed unit leaders from the 3/2 SBCT, 1/25 SBCT, and 101st ABD to evaluate performance and collaboration. The 3/2 SBCT performance was rated very high for conducting major combat operations, accelerated planning and battle tempo, reacting to enemy attacks and changes in the environment. The 3/2 also had extremely low casualty rates. The force agility, adaptability, responsiveness, and innovation found during the CERTEX case study were evident in the 3/2 SBCT in Iraq. Its performance in the political stability operations portion of the mission was not rated as well. The 1/25 SBCT and 101st ABD significantly outperformed the 3/2 in the stability mission, which was attributed to additional resources provided to the 1/25 SBCT and the 101st ABD, and some specific challenges faced by 3/2 that the other units did not encounter.

The 1/25 SBCT also showed significant speed and agility during offensive operations, and responsiveness to enemy attacks, but it also performed very well in the stability operations. The 1/25 SBCT demonstrated that it could quickly redirect personnel to address emerging opportunities without the necessity of much advance planning. The 1/25 SBCT also showed surprising success during HVT and counter infiltration operations. At one point, it captured key insurgent leaders in Mosul, provided security for voters at polling sites, and reestablished political dialog between various ethnic groups. The 1/25 SBCT was largely credited for the return of political stability to Mosul (Gonzales et al., 2007).



Figure 13. Stryker Armored Vehicle (From: <http://www.ausa.org>, 2006)

### C. CONCLUSION

Examination of the case studies revealed some consistent themes related to why and how organic organizations perform well in unstable, dynamic and complex environments. Many of these themes correlated with similar themes that emerged from the synthesis of the literature. Mintzberg (1979), and Alberts and Nissen (2009) emphasized the importance of liaisons to provide horizontal or lateral linkages between organizational subunits and also among organizations collaborating in pursuit of a common objective. These linkages facilitate the movement of critical and timely information through an organization or among various organizations to those who need it. Mintzberg called these “liaison devices” (1979, pp. 161–162). The case studies of Operation Talavera, Operation Chimera, and the DNC 2000 all had examples of the TEW making extensive use of liaisons to improve performance and function more organically. During Operation Talavera, a critical liaison was the exchange of personnel between the

TEW and the FBI. During Chimera, the TEW's Epi-Intel Cell Leader was embedded in the TAG. The terrorism liaison officers were a critical lateral link in all of the case studies involving the TEW. The extensive use of liaisons supports greater levels of peer-to-interaction and broad distribution of information (Alberts & Nissen, 2009).

During Operation Chimera, the TEW combined the epi-intel cell with the analysis/synthesis cell, which changed the organizational structure. Flexible organizational structure correlates to another common theme in the literature (Alberts & Hayes, 2003, p. 139; Tushman & Nadler, 1978, p. 621; Mintzberg, 1979, p. 433). Flexibility emerged in the literature as a central characteristic of organic forms and was said to contribute to its performance in ambiguous environments. The TEW's complete integration of one organizational subunit into another to fit the situation is an extreme example of flexibility. TEW's performance during Chimera produced another observable phenomenon that correlated with the literature on organic design, which was emergent leadership (Alberts & Hayes, 2003). When the TEW allowed its epi-intel cell to take the lead for the operation because of the fit between the functional discipline of the cell and the environment, the organization demonstrated that it could perform at a high level of effectiveness in a dynamic and complex environment.

In the CERTEX case study, the SBCT allowed its subordinate commanders to adapt the battle plan around new information to avoid a direct confrontation with enemy forces and accelerate the timetable. These changes led to a decisive victory and proved to be the pivotal engagement of the exercise. This course of events epitomized the SBCT's doctrine of decentralized decision authority, and significantly contributed to organizational performance. Decentralized decision rights are a central feature of organic forms and the literature highlights this variable as a necessary feature for success in dynamic and complex environments (Mintzberg, 1979, pp. 273–281; Alberts & Nissen, 2009). This organizational characteristic was also at work in the northern Iraq case study during the downed helicopter incident in Tal Afar, and when battalion commanders split the force on the way to Najaf. The SBCTs also demonstrated an important characteristic of organic organization that contributed to high performance—innovation—with its use of sophisticated digital communication networking technology. Technology not only

provided innovation for the SBCTs, but also acted as a liaison in a sense, establishing strong and reliable lateral linkages for the rapid and accurate dissemination of information. Complexity presents challenges, but also offers opportunities if an organization can leverage innovation. In the case of the SBCTs, the technology provided that opportunity.

Organic design features that contributed to superior operational performance during the case studies included the extensive use of liaisons, emergent leadership, decentralized decision authority, peer-to-peer interaction, broad distribution of information, and the use of innovative technology. The SBCTs and the TEW performed well in dynamic and complex environments because they ultimately exhibited organizational characteristics including agility, responsiveness, flexibility, adaptability, and innovation. These characteristics are restated repeatedly in the literature as central to organic design and critical in dynamic and complex environments.

THIS PAGE INTENTIONALLY LEFT BLANK

## V. DATA ANALYSIS

The aim of this research was to seek an understanding of why and how organic organizational designs perform well in unstable, dynamic and complex environments, but the project did not begin with this specific objective in mind. Qualitative social research can at times be chaotic, and organizing that chaos becomes the journey through which the researcher must travel. During such a journey, unexpected information and conclusions are not uncommon. Data emerge from a wide variety and sometimes, unexpected sources, which then requires a blend of synthesis methodology that is systematic, scientific, and yet somewhat thematic if not a bit interpretive. This research was no different. A simple question of whether a networked organization would outperform a hierarchy in a complex environment, evolved into a much wider view of organic designs versus mechanistic ones, and ultimately, led to asking why and how, which are not easy questions to consider.

In the course of this journey, some realities had to be taken into account. The nature of case study research does not lend itself to repeatable experiments, nor does it typically involve limited sets of variables that can be easily controlled out of the analysis. In fact, the case studies encompassed in this research in particular were immersed in complex and dynamic environments and involved several complex organizations, in which many variables simply could not be separated from the analysis. Time constraints for completion of the research collided with the human subjects institutional review requirements (IRB). The IRB process would have taken valuable research time to complete. Given the huge amount of written data that had to be collected and analyzed, not enough time remained to pursue all of the available sources of data; therefore, human subject interviews had to be dropped from the research plan. This omission was a difficult decision considering the richness that those interviews could have added to such research, but on balance, a necessary sacrifice to meet deadlines and properly analyze the written data.

This analysis was based upon a combination of a thorough review of related documents, published secondary material, extensive personal experience, some direct participation and observation, and in some cases, informal conversations with participants going back several years prior to the start of this research. From this amalgam of information, a picture began to emerge. This picture was messy at times, and ultimately, required distillation using a series of progressive scales developed from an understanding of the salient points in the organization and management literature. The distilled thematic variables that emerged were then considered against the narratives of the cases in an effort to answer the questions of why and how organic organizational forms perform effectively in unstable, dynamic, and complex environments.

#### **A. DISTILLATION PROCESS**

The first step in this distillation process was to examine the literature for some common, but generally broad characteristics that suggest an organization is oriented more toward the organic end of the continuum than the mechanistic. Once these characteristics were identified, a scale was developed to assess the presence or absence of each during all the case studies, and therefore, develop a qualitative measure of the organization's design orientation in the context of the specific case. The next step in the analysis was to determine if the organizations were effective during the case studies using some reasonably objective criteria, which was established with a series of yes or no questions. Next, the analysis attempted to separate the individual elements of the organic organizations that contributed to their effectiveness—the “how.” This separation was accomplished by matching organizational elements with those identified in the literature. The OMT literature has identified a well-established set of organizational elements that contribute to design. These elements can be assessed based on three overall thematic variables (Alberts & Nissen, 2009).

- Allocation of decision rights
- Patterns of interaction
- Distribution of information

Alberts and Hayes (2003) emphasized agility as a fundamental characteristic of organic organizational forms, and an important quality for organizations operating in the



Information Age (pp. 56, 123). Agility was a characteristic that surfaced repeatedly in the literature as common to organic design, and as a distinct advantage in dynamic and complex environments (Daft, 2009, pp. 25–30, Bell & Joroff, 2001, p. 10; Alberts, 2010). Responsiveness, or the capacity to respond to and exploit opportunities quickly, is another characteristic commonly associated with organic design. The related characteristics of flexibility—the capacity to meet objectives using various methods, adaptability—the capability to modify tactics to meet changing conditions, and innovation—the capacity to utilize new techniques, resources and technologies all emerge as salient within organic organizations and critical in complex environments (Alberts & Hayes, 2003, pp. 141–151). The following characteristics provide a basic definition used for this analysis.

- **Agility**—The organization quickly shifts priorities and resources to manage dynamic and evolving environments. Agility implies a nimbleness of movement or easily redirected momentum.
- **Responsiveness**—The organization responds to and exploits emerging and unexpected opportunities to meet its objectives. Responsiveness implies a timely reaction to environmental change.
- **Flexibility**—The organization can and does change strategies, tactics and even team composition to adjust to changing domains. This characteristic leverages multiple methods to reach success and the ability to shift between those methods.
- **Adaptability**—The organization modifies tactics to meet rapidly changing demands and challenges. The organization can even modify its form to meet challenges.
- **Innovation**—The organization uses novel techniques, technologies and resources to meet objectives, which implies either something new or something old, but achieved in some new way.

The scale used to assess the presence or absence of each of these characteristics was based on a numeric value between 1–10, with 1 being the least organic and 10 being the most.

**1-2** = Never associated with the organization

**3-4** = Rarely, but sometimes associated with the organization

**5-6** = Occasionally, but not consistently associated with the organization

**7-8** = Consistently, but not always associated with the organization

**9-10** = Nearly always associated with the organization

	<b>Talavera Operations</b>	<b>Talavera TEW</b>	<b>Chimera TEW</b>	<b>DNC TEW</b>
Agility	3	8	8	9
Responsiveness	4	9	9	10
Flexibility	2	8	10	8
Adaptability	3	9	10	9
Innovative	4	8	9	9

Table 1. Organizational Characteristics of Intelligence and Emergency Responder Organizations (From: LA TEW and Operations Section)

	<b>CERTEX SBCT</b>	<b>IRAQ ABD</b>	<b>IRAQ 3/2</b>	<b>IRAQ 1/25</b>
Agility	9	8	9	9
Responsiveness	9	8	9	9
Flexibility	7	4	7	7
Adaptability	9	6	9	9
Innovative	10	5	10	10

Table 2. Organizational Characteristics of Military Organizations (From: 3/2 SBCT, 1/25 SBCT and 101st ABD)

All of the organic organizations scored high in agility across the spectrum of cases in this research, since all of them had opportunities to adjust and change momentum in the face of new information, and did so with relative ease. The TEW score particularly high for flexibility and adaptability during Operation Chimera because it actually integrated one entire team into another and changed its organizational structure to address the environment. In Chimera, the nature of the threat, which was epidemiological, required the TEW to demonstrate flexibility of form, emergent leadership, adaptability, and a general responsiveness to the conditions on the ground. TEW also scored high on responsiveness during the DNC 2000 because it assessed the changing tactics of the protest groups, disseminated that information and suggested countermeasures. The SBCTs scored consistently high on innovation during the CERTEX and operations in northern Iraq because of their extensive use of advanced digital technologies to enhance communication, coordination and synchronization. The networking systems they employed are highly innovative and contributed heavily to their strong performance.

Alternatively, the operations section during Operation Talavera scored particularly low on flexibility because the strict hierarchy and rigid, formalized chain-of-command failed to address changing conditions in the environment, which led to communication breakdowns. Flexibility was also a weakness of the 101st ABD during operations in Iraq, which led to a lengthened attack planning cycle and impacted its agility. The ABD's use of analog radio communications technology during the operations in Iraq degraded its ability to communicate and share information, which slowed its ability to react to changes in the environment. For this reason, the 101st ABD scored low on innovation.

The next step in the analysis was to determine if the organizations were effective during the case studies using some reasonably objective criteria, even though "effectiveness" is an inherently subjective quality to evaluate. The criteria included the following considerations, which were gleaned from the literature (Alberts & Hayes, 2003).

- **Mission Objectives**—Were the objectives of the operation reasonably met?
- **Information Speed**—Did the speed of information flow meet the demands of the dynamic and complex environment?
- **Information Quality**—Was the information accurate? Did the information add to overall performance?
- **Convert Information to Action**—Was the information quickly converted into action in support of the operational objectives?
- **Organizational Learning**—Did organizational learning occur?
- **Shared Situation Awareness**—Did the organization achieve shared situational awareness or a "common operating picture?"
- **Decision Quality**—Did the decisions of leadership lead to positive outcomes?
- **Self-Synchronization**—Did the organization synchronize its activities?

The TEW and the SBCT did meet their stated operational objectives for each of the cases, as documented in the data sources. In the case studies involving the TEW, the after action reports emphasized that objectives were achieved. It was determined through the totality of the data that the TEW also fulfilled the remaining criteria, with the

exception of organizational learning, which could not be determined from the data. The secondary source materials published by Rand from the CERTEX and northern Iraq case studies on the SBCTs specifically discussed all of the criteria, and the reports reflected that they successfully met all of the established objectives to demonstrate operational effectiveness in the environment. The Rand reports rated information accuracy as high based on interviews conducted for the report. The SBCTs did convert information into action quickly and efficiently, which was evident in their accelerated attack planning cycles and the “information advantage” that enabled them to outmaneuver and surprise enemy forces. They also established shared situational awareness and achieved self-synchronization. Conversely, the operations section did not meet all of its objectives during Operation Talavera, and information was slow to reach those that needed it, which impacted effectiveness. Information speed was also a concern for the 101st ABD in Iraq. The information lag slowed its attack planning cycle when compared to the 3/2 SBCT and the 1/25 SBCT.

The next analysis step was to attempt to separate some of the individual elements of the organic organizations that particularly contributed to their effectiveness—the “how.” Matching observed elements during the case studies to the literature helped this process. The OMT literature has identified a set of organizational elements that contribute to design (Galbraith, 1973; Galbraith, 1977; Mintzberg, 1979; Mintzberg, 1980; Alberts & Hayes, 2003; Alberts & Nissen, 2009). These elements include the following.

- **Centralization**—The degree to which power and control are concentrated within a central command structure, or distributed out to subordinate commanders or even line level personnel.
- **Specialization**—The degree to which division of labor is utilized to accomplish goals. Vertical specialization refers to specific duties delegated down through the chain of command and horizontal specialization refers to division of tasks by function.
- **Formalization**—The degree that work is formally defined through written manuals or procedures.
- **Use of Liaison Devices**—People or processes that create lateral linkage for horizontal interaction and communication.

- **Planning and Control Systems**—The degree to which planning and control are predetermined specifically or guided by intent and outcome. Action planning or the process to predetermine what steps will be taken is at one end of this spectrum of measurement and performance controls or the regulation of performance to attain overall objectives is at the other.
- **Emergent Leadership**—The degree to which subordinate leaders, individuals or specialized teams were allowed to take the lead to address a particular problem set or challenging aspect of the environment.

With the exception of emergent leadership, which was added as a critical element in this research, Alberts and Nissen (2009) developed a series of matrices to assess the aforementioned elements and apply them to each of three thematic variables, allocation of decision rights, patterns of interaction, and distribution of information. They plotted these results on a three-dimensional model referred to as a “Metaphorical Rosetta Stone” (pp. 39–45). The three variables were plotted along three corresponding axes to depict visually where an organization was operating in a three-dimensional space. The Alberts and Nissen Rosetta Stone model and its matrices served as useful tools for this analysis. They were not only used here to depict the organizational orientation of the TEW and the SBCT as they performed during the case studies, but also to identify and define salient design elements that contributed to organizational effectiveness in the environment. The matrices and the three-dimensional model offered a more systematic method to corroborate anecdotal observations presented in the case study chapter and supported in the preliminary analysis.

In the first matrix, the Allocation of Decision Rights (ADR) variable is separated by element and aligned with the organization type, using Mintzberg’s (1979) typologies, along with the Alberts and Hayes’ edge organizational type. TEW was depicted as more decentralized, less formalized and specialized than the SBCT. Their networked organizational structure and operating environment allowed the TEW to be more organic. The SBCT was generally organized as a hierarchy and maintained a chain of command consistent with military organizations, but with the ability to flex into a more organic orientation as the environment became more dynamic and complex. The SBCT was, therefore, depicted as a more balanced organization when viewed through the ADR lens. The subordinate commanders sometimes followed pre-designed plans and sometimes

adapted their plans to fit the overall command intent, but with no particular specifics as to how to achieve the objective. Although supported in both organizations, emergent leadership was more prevalent in the TEW than the SBCT. Emergent leadership allowed for periodic shifts as to which subordinate leader or team took the operational lead consistent with their expertise, geographic location relative to the mission, or a range of other deciding factors.

	<b>Machine</b>	<b>Simple</b>	<b>Professional</b>	<b>Adhocracy</b>	<b>Edge</b>
<b>ADR</b>	Unitary	Mostly Unitary	Balanced	Mostly P2P	P2P
TEW ⇒				X	
SBCT ⇒			X		
<b>Centralization</b>	High	High	Low	Low	Low
TEW ⇒				X	
SBCT ⇒			X		
<b>Vertical Specialization</b>	High	High	Low	Low	Low
TEW ⇒				X	
SBCT ⇒			X		
<b>Horizontal Specialization</b>	High	Low	High	High	Low
TEW ⇒					X
SBCT ⇒			X		
<b>Emergent Leadership</b>	Discouraged	Not Supported	Neutral	Supported	Well Supported
TEW ⇒					X
SBCT ⇒				X	
<b>Formalization</b>	High	Low	Low	Low	Low
TEW ⇒				X	
SBCT ⇒			X		

Table 3. Matrix of Elements Associated with the Allocation of Decision Rights/Based on Concept by Alberts and Nissen (From: Alberts & Nissen, 2009)

When breaking down Patterns of Interaction (POI) as a design variable, the TEW was assessed to be unconstrained, with organization members and cells (teams)

interacting with almost no restrictions. The SBCT was mostly unconstrained, but any military organization would find it difficult to operate with no interaction restrictions. The SBCT followed a basic chain-of-command, but allowed for some peer-to-peer and multi-echelon interaction, which was facilitated by the use of the digital technology. Both organizations operated in the case studies with low formalization, but to varying degrees. Finally, both the TEW and SBCT made extensive use of liaisons and mixed action planning with performance control.

	<b>Machine</b>	<b>Simple</b>	<b>Professional</b>	<b>Adhocracy</b>	<b>Edge</b>
<b>POI</b>	Constrained	Mostly Constrained	Balanced	Mostly Unconstrained	Unconstrained
TEW ⇒					X
SBCT ⇒				X	
<b>Formalization</b>	High	Low	Low	Low	Low
TEW ⇒				X	
SBCT ⇒			X		
<b>Liaison Devices</b>	Few	Few	Some	Many	Many
TEW ⇒					X
SBCT ⇒				X	
<b>Planning &amp; Control Systems</b>	Action Planning	Little	Little	Some Action	Performance Control
TEW ⇒				X	
SBCT ⇒				X	

Table 4. Matrix of Elements Associated with the Patterns of Interaction/Based on Concept by Alberts and Nissen (From: Alberts & Nissen, 2009)

The Distribution of Information (DOI) varied from mostly uncontrolled to uncontrolled in both organizations, but for different reasons. The TEW utilized its networked system of cells or teams to move information with little or no restriction. They also consistently used the TLOs as liaisons. The SBCT used some liaison positions and embedded personnel to move information, but it was the almost instantaneous dissemination of information through their advanced digital communication network that had the greatest impact on operational effectiveness. Therefore, it was established they

both used liaisons extensively, but the SBCT used its technology as a liaison device. Both the TEW and SBCT mixed action planning with performance control. The SBCT used specific plans to map out mission objectives and the specific tasks to accomplish those objectives, but also allowed for performance controls or the adaptation of the original plan within the command intent to meet objectives without a specific set of directives to mandate how those objectives were met. The decision whether to follow established plans or adapt was situational and greatly dictated by the complexity of the environment.

	<b>Machine</b>	<b>Simple</b>	<b>Professional</b>	<b>Adhocracy</b>	<b>Edge</b>
<b>DOI</b>	Controlled	Mostly Controlled	Balanced	Mostly Uncontrolled	Uncontrolled
TEW ⇒				X	
SBCT ⇒					X
<b>Liaison Devices</b>	Few	Few	Some	Many	Many
TEW ⇒					X
SBCT ⇒				X	
<b>Planning &amp; Control Systems</b>	Action Planning	Little	Little	Some Action	Performance Control
TEW ⇒				X	
SBCT ⇒				X	

Table 5. Matrix of Elements Associated with the Distribution of Information/Based on Concept by Alberts and Nissen (From: Alberts & Nissen, 2009)

Using the Rosetta Stone model of Alberts and Nissen to plot the three thematic variables (ADR, POI and DOI) for the TEW and the SBCT, this analysis attempted to place a “value” on how organic each organization was in the case studies. This analysis is not a precise quantitative measurement, but a visual depiction that provides a systematic albeit subjective assessment of where each organization operated within the space during the case studies. In the first diagram (Diagram 1), the three-dimensional box shows the placement of a purely mechanistic organization and an edge organization as a reference. If an organization were at either of the extreme ends of the mechanistic-organic continuum, the box would look like this. The second diagram (Diagram 2) depicts the



relative placement of an edge organization in the space along with Mintzberg’s organizational types—adhocracy, professional bureaucracy, simple, and mechanistic. The third diagram (Diagram 3) then illustrates the placement of the TEW and the SBCT in the design space. The Rosetta Stone model illustrates that organizational design is not an all-or-nothing proposition—not black and white. Very small incremental degrees of change to any of the three variables can move an organization toward the organic or mechanistic end of the continuum. When an organization changes a process or structure that impacts the presence or absence of one of the subelements, it also moves one of the variables, and in turn moves the organization’s orientation within the design space. The case studies demonstrate that those changes can occur even within a traditional hierarchy (SBCT) when the environment or some other contingency requires it, given some flexibility. The TEW and the SBCT certainly demonstrated that flexibility when faced with a dynamic and complex environment.

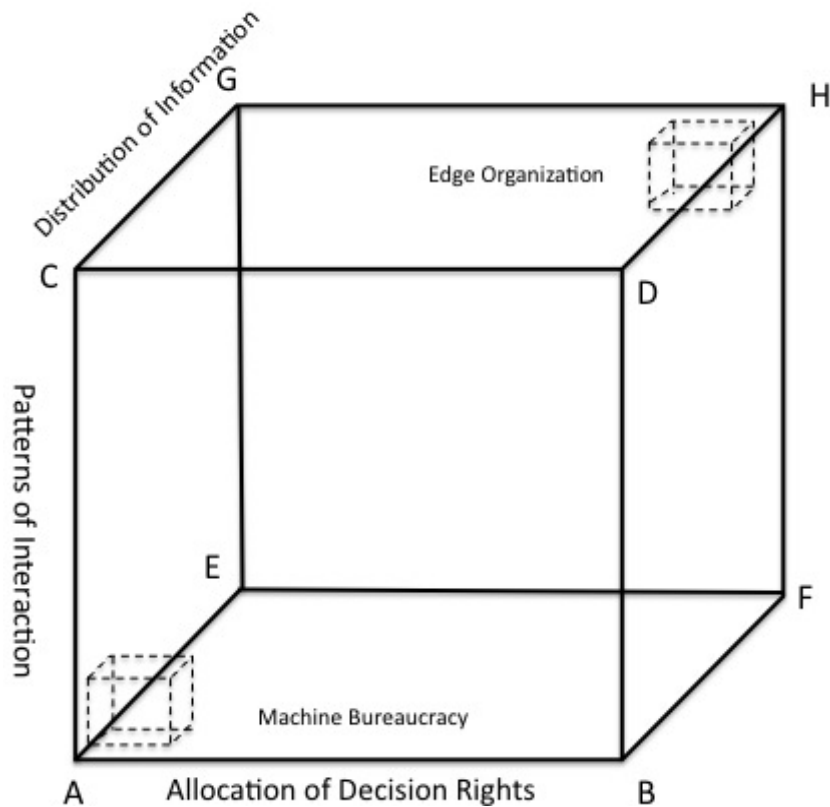

Diagram 1. Rosetta Stone Model Depicting a Machine Bureaucracy and an Edge Organization/Based on Concept by Alberts and Nissen (From: Alberts & Nissen, 2009)

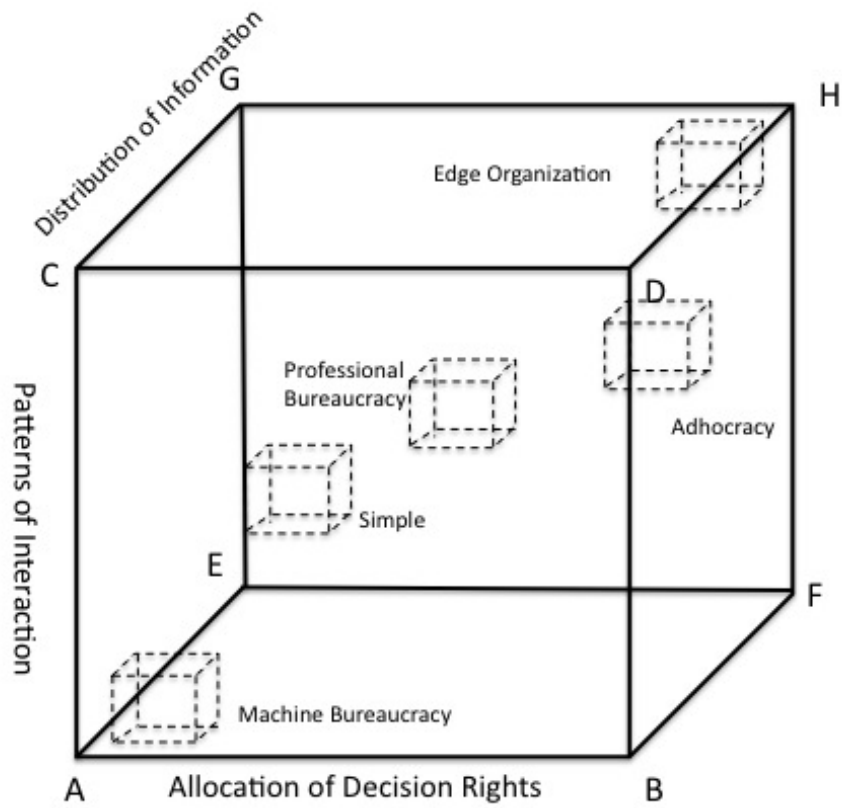

Diagram 2. Rosetta Stone Model Depicting Mintzberg's Organizational Types and an Edge Organization/Based on Concept by Alberts and Nissen (From: Alberts & Nissen, 2009)

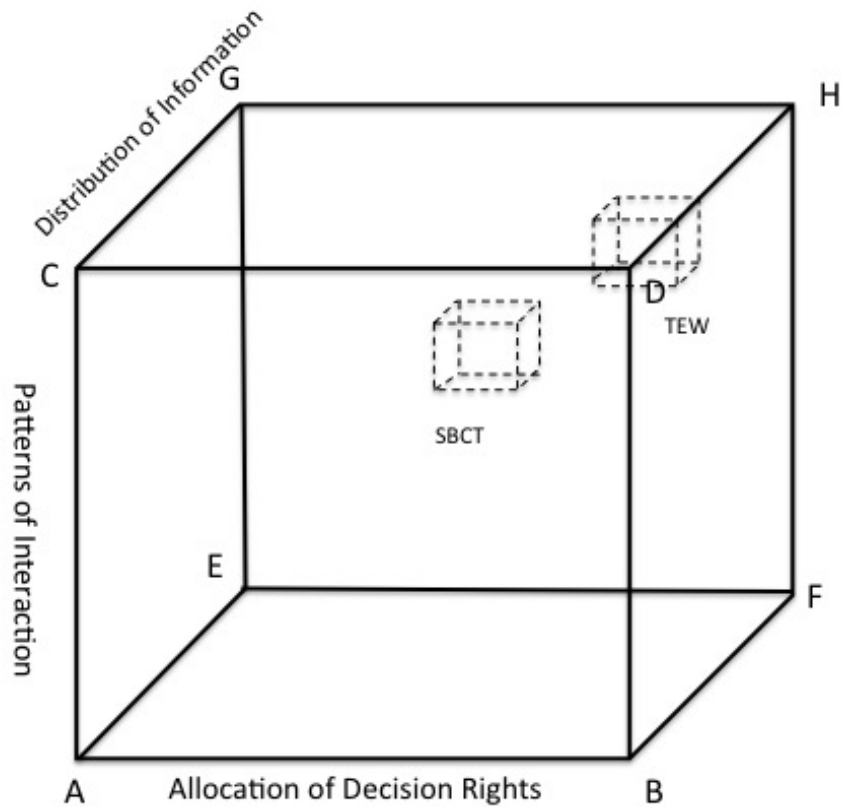

Diagram 3. Rosetta Stone Model Depicting the SBCT and LA TEW/Based on Concept by Alberts and Nissen (From: Alberts & Nissen, 2009)

## B. CONCLUSION

This research sought to explain why and how organic organizations perform well in unstable, dynamic and complex environments. The literature offered some clues, but the case studies provided an opportunity to observe real organizations operating in this type of environment. This study was the story of how the individuals, leaders and subunit (teams) of an organization adjusted their processes to exhibit a more organic form, and in so doing, improved performance when the environment demanded it.

A dynamic environment is fast paced, ever changing and adapts to new circumstances. Little time exists to mull over information and compose elaborate plans based on some best practice from a prior experience. When complexity is added to the mix, uncertainty and unpredictability occur—decisions have to be made with less than ideal information and the possibility of unpredictable outcomes. This environment

requires an ability to first gather and move information quickly. Organic forms seem to provide this information speed because they do not follow a hierarchy with a centralized power base, in which information can be trapped in silos. Organic forms use liaisons to connect various subunits, which serves to optimize the movement of information further. The second demand of dynamic and complex environments is sense-making. It is not enough to simply collect and move information quickly. Decision-makers must make quick sense of its meaning to facilitate timely and appropriate action. The cases in this research demonstrated that emergent leadership, in which the individuals or teams with the expertise to make the best sense of a situation were allowed to assume a leadership role even though it might only be temporary. Organic forms seem to support the concept of emergent leadership so they are well positioned to make sense of dynamic and complex environments. Sense-making needs to be distributed across the organization so that all members understand what is happening, which is shared situational awareness, or common operating picture. Peer-to-peer interaction and broad distribution of information accelerate the acquisition of shared situational awareness. Since organic forms support peer-to-peer interaction and broad distribution of information, they seem to reach shared situational awareness very quickly, which acts to aid in sense-making. The final step involves converting information to action. At this point, an organization has collected and disseminated information, made sense of the situation, but now must decide what actions to pursue. Since dynamic environments generally offer little time for this process to occur before change and adaptation are added, decisions must be timely and appropriate. Centralized decision authority as it occurs in many traditional mechanistic organizations can slow decision-making. In these cases, the subordinate commanders and teams were given some authority to make situational decisions based on information and expertise possessed by those personnel. Decentralized allocation of decision rights is supported in organic organizations, and as is demonstrated in this research, it is useful for rapid conversion of information into action in dynamic and complex environments. Decision making in such environments also appears to be aided by some degree of flexibility in

planning. When decisions can be guided by performance controls and command intent rather than specifically outlined steps or tasks, decision-makers are afforded flexibility often demanded in dynamic and complex environments.

Organic forms seem to perform well in dynamic and complex environments because they support design features that optimize information collection and dissemination, and then quickly make sense of that information. They also enhance effectiveness in such environments because they provide decision-makers with tools to accelerate the conversion of information into action. Organic forms seem to be the right “fit” for dynamic and complex environments.

Organic forms seem to strive for organizational agility, flexibility, adaptability responsiveness and innovation using elements, such as decentralization, emergent leadership, liaison devices, adaptive planning strategies and an emphasis on low formalization. Ultimately, these elements impact the three primary variables of allocation of decision right, patterns of interaction and distribution of information, which is how they seem to thrive in dynamic and complex environments.

THIS PAGE INTENTIONALLY LEFT BLANK

## VI. FINDINGS AND RECOMMENDATIONS

The findings of this research support a widely accepted view in the contingency theory literature that no single organizational design is optimal in all situations; nor do all designs perform with equal effectiveness. The relationship between design and situational variables is critical (Galbraith, 1973, pp. 2–6; Galbraith, 1977, p. 28; Mintzberg, 1979, p. 11). This research further supports the concept in the literature that mechanistic organizations provide a better fit in stable and simple environments, while organic designs exhibit more suitable fit in unstable, dynamic and complex environments (Burns & Stalker, 2001, pp. 119–125; Lawrence & Lorsch, 1967, p. 188; Galbraith, 1973, p. 4; Galbraith, 1977, pp. 28–29; Mintzberg, 1979, pp. 84–94). In the search for an explanation of why this is so and how it might work, the research revealed critical organizational characteristics, such as agility, responsiveness, flexibility, adaptability, and innovation as keys to both organic design and operational performance in unstable and complex environments. The research correlated the organizational variables of allocation of decision rights, patterns of interaction and distribution of information with these characteristics to provide further explanation of why organic designs perform well in unstable and complex environments. The presence of design elements, such as decentralized decision authority, emergent leadership, less formalization, increased use of liaisons, and planning and control systems that rely upon performance-based objectives are some of the concepts that explain how an organization can be simultaneously more organic and more effective in unstable and complex environments. The characteristics, variables and design elements found to be salient in the case studies correlated with concepts synthesized from the literature (Burns & Stalker, 2001; Lawrence & Lorsch, 1967, Galbraith, 1973; Mintzberg, 1979; Mintzberg, 1980; Joroff, 2001; Alberts & Hayes, 2003; Alberts & Nissen, 2009).

Organic organizational designs provide a better fit in unstable, dynamic and complex environments because they leverage three capabilities critical in these environments, which are communication dissemination, sense-making and timely conversion of information to action. Since unstable, dynamic and complex environments

exhibit rapid change, adaptation, uncertainty, unpredictability, and nonlinearity, they demand organizations that can collect and disseminate information rapidly and efficiently, can make sense of the situation quickly, and can convert that knowledge into timely and appropriate action. Since organic forms are designed with these capabilities integrated, they perform better in such environments than more mechanistic forms, which is the “why” that emerged from the research.

Organic designs perform better by supporting the design elements that include decentralized decision authority, emergent leadership, low specialization, low formalization, the use of liaisons, and a reliance on performance controls. These elements contribute to the design variables that include decentralized allocation of decision rights, unconstrained patterns of interaction, and broad distribution of information. The variables support the organizational characteristics associated with organic design and superior performance. Figure 14 illustrates this progression, in which the elements support design variables that support the characteristics and contributes to the factors used to measure performance. Therefore, the incorporation of the design elements ultimately leads to high performance in unstable, dynamic and complex environments, which is the “how” that emerged from the research.



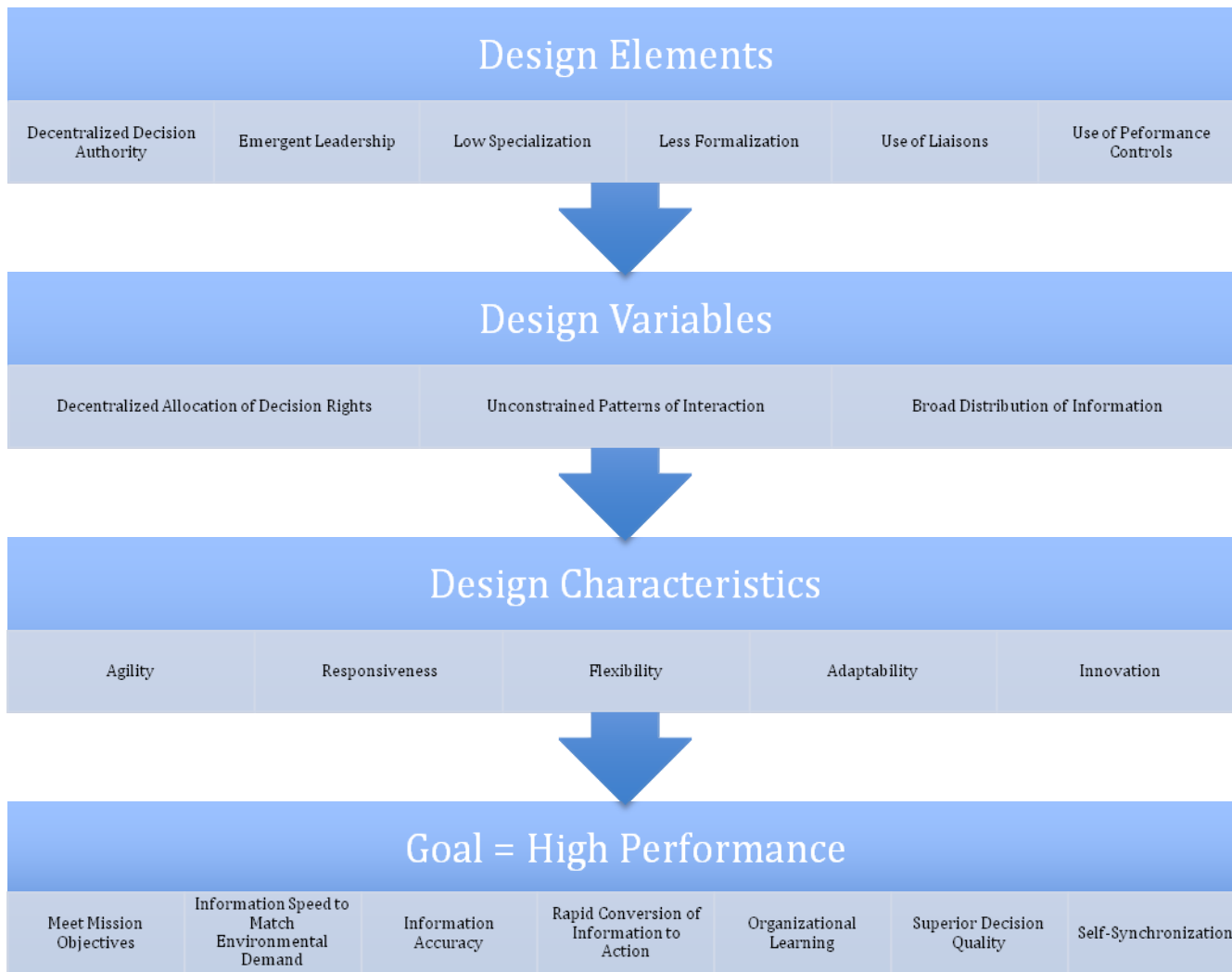

Figure 14. Organizational Design Progression

The research offers significant opportunities for both researchers and homeland security leaders. The first opportunity is for further research to examine the more detailed aspects of these findings. The second opportunity is for public organizations either to reshape their design in general, or to at least, shift to a more organic orientation when the environment becomes more unstable and complex.

#### **A. FUTURE RESEARCH: INVESTIGATING THE DETAILS**

A need exists for additional research into organizational elements and their relationship on both organic design and operational performance in unstable and complex environments. The nature of case study research does not allow variables to be controlled out; thus, future research can be designed in a more controlled setting. In a controlled experiment in which all variables remain the same except one, that variable can be evaluated for its impact in this area. As an example, a group could be assembled to solve a simulated set of problems that are both complex and dynamic in nature, but one group can be allowed to use emergent leaders or any of the individual design elements identified in this research. This kind of very specific controlled experiment might help to add to an understanding of the particular elements being controlled, and would serve to validate or refute the findings in this study.

#### **B. PRACTICAL IMPLEMENTATION OF THE FINDINGS**

Homeland security organizations can use these findings to adjust their design. This adjustment can be a structural change to move the design to a more organic orientation, or a variation of the processes to enable a better fit temporarily for an unstable and complex environment. Since homeland security organizations are not always faced with complex environments, the ability to shift design orientation to suit the environment has great potential. Organizations have tools, such as doctrine, leadership and training, to support and prepare for shifts to more organic orientation.

##### **1. Establishing Doctrine**

Organizations can begin by establishing a set of overarching themes for success in unstable and complex environments and in support of organic design—a philosophy or

doctrine. This formation could be used as a tool to facilitate decentralization and performance controls to achieve a more organic design when needed. When decision authority is decentralized and orders are adapted to fit unstable and complex environments, such a doctrine serves as a guide. The SBCT has such a doctrine. Commanders are given authority to execute detailed orders that support centralized execution or “mission-type” orders that support decentralized execution in accordance with command intent, based on the situation. These adapted orders can be prepared more quickly using specific knowledge of the terrain and general conditions. This adaptation is a part of the pre-designated “doctrine” of the SBCT, which also includes technological innovation for communication and collaboration, as well as the use of organic embedded specialty units to improve information distribution, and command and control. This doctrine supports the SBCT concept of, “see first, understand first, act first, and finish decisively.”

The establishment of doctrine in support of organic design principles is more than just symbolic. Doctrine lays the foundation for organic design in anticipation of the complex environment that will signal its employment.

## **2. Leadership Development**

If organic design principles are to be employed in complex environments, organizations must work in advance to develop leaders who are agile, adaptive, flexible and highly competent in ambiguous settings. These types of leaders are comfortable operating without specific guidance from centralized command. The SBCT has developed a leadership model that reflects these ideals in support of organic design principles. SBCT leaders are confident using innovative technologies for command and control, and they can make sound tactical decisions either in accord with a centralized plan or within the construct of command intent. The leadership philosophy of the SBCT blends the analytical and the creative skill sets in their leaders to drive for mission success through a variety of means.

Organic design starts with organic leadership and the characteristics of the leader should mirror those of the organic form. Leadership that embraces those principles, and has the confidence and competence to employ them, supports a doctrine of organic design principles.

### **3. Training**

Training is a key component in the establishment of organic design principles. Decentralized decision authority can only be employed if subordinate commanders and key line personnel have the proper training to make critical decisions, which is especially true in unstable and complex environments. Organizations are more likely to adopt organic design and decentralize decision rights if they have confidence in lower-echelon personnel to make such decisions. The establishment of this confidence begins with training. The Stryker brigades rely heavily on training and simulation in similar environments they will face in battle to develop the ability of subordinate commanders to plan, collaborate and act decisively without specific direction from the centralized command.

## LIST OF REFERENCES

- Ahmed, E., Elgazzar, A. S., & Hegazi, A. S. (2005, March 28). On complex adaptive systems and terrorism. *Physics Letters A*, 337(1–2), 127–129.
- Alberts, D.S., & Hayes, R. E. (2003). *Power to the edge: Command and control in the information age*. Washington, DC. CCRP Publication Series.
- Alberts, D.S. (2007). Agility, focus, and convergence: The future of command and control. *The International C2 Journal*, 1(1), 1–30. Retrieved from <http://www.dodccrp.org>
- Alberts, D.S., & Nissen, M. E. (2009). Toward harmonizing command and control with organization and management theory. *The International C2 Journal*, 3(2), 1–59. Retrieved from <http://www.dodccrp.org>
- Alberts, D. S. (2010, March 30). The agility imperative: Precis. [Unpublished white paper] CCRP. Retrieved from <http://www.dodccrp.org>
- Arquilla, J., & Ronfeldt, D. (1993, Summer). Cyberwar is coming! *Comparative Strategy*, 12(2), 141–165.
- Association of the United States Army. (2006, June). Accelerating momentum: The Stryker Brigade Combat Team as a learning organization. *Torchbearer National Security Report*, 1–28, The Institute of Land Warfare. Retrieved from <http://www3.ausa.org/webpub/DeptILW.nsf/byid/JSUR-6QLHTM>
- Axelrod, R., & Cohen, M. D. (2000). *Harnessing complexity: Organizational implications of a scientific frontier*. New York, NY: Basic Books.
- Barabasi, A. L. (2003). *Linked: How everything is connected to everything else and what it means for business, science and everyday life*. New York: Plume Publishing.
- Baxter, P., & Jack, S. (2008, December). Qualitative case study methodology: Study design and implementation for novice researchers. *The Qualitative Report*, 13(4), 544–559.
- Bell, M., & Joroff, M. (2001). *The agile workplace: Supporting people and their work*. Cambridge MA: Gartner and the Massachusetts Institute of Technology.
- Bellavita, C. (Ed.) (1990). *How public organizations work: Learning from experience*. New York: Praeger.
- Bellavita, C. (2005, Summer). What is preventing homeland security? *Homeland Security Affairs Journal*, 1(1). Retrieved from <http://www.hsaj.org/?fullarticle=1.1.3>

- Bellavita, C. (2006a). Changing homeland security: What should homeland security leaders be talking about? *Homeland Security Affairs Journal*, 2(2). Retrieved from <http://www.hsaj.org/?fullarticle=2.2.3>
- Bellavita, C. (2006b). Changing homeland security: Shape patterns, not programs. *Homeland Security Affairs Journal*, 2(3). Retrieved from <http://www.hsaj.org/?fullarticle=2.3.5>
- Bodhanya, S. (2010, July 8). Science, complexity and organisation. *TEDxUKZN*. Video podcast retrieved from <http://www.youtube.com/watch?v=tCdIdq5YI-M&p=5F8A01767F7DEA44&playnext=1&index=6> .  
<http://tedx.ukzn.ac.za/shamim.aspx>
- Brafman, O., & Beckstrom, R. A. (2006). *The starfish and the spider: The Unstoppable power of leaderless organizations*. New York: Penguin Books.
- Bram, J., Orr, J., & Rapaport, C. (2002, November). Measuring the effects of the September 11 attack on New York City. *FRBNY Economic Policy Review*, 8(2), 5–20.
- Brand, S. (2009). *Whole earth discipline: Why dense cities, nuclear power, transgenic crops, restored wildlands, and geoengineering are necessary*. New York: Penguin Books.
- Buchanan, M. (2001). *Ubiquity: Why catastrophes happen*. New York, NY, USA: Three Rivers Press.
- Bunker, R. J. (1998). Five-dimensional (cyber) warfighting: Can the Army after next be defeated through complex concepts and technologies? *Strategic Studies Institute*.
- Burns, T., & Stalker, G. M. (2001). *The management of innovation*. London: Oxford University Press. (Original work published 1961).
- Carafano, J. J., & Weitz, R. (2009, April 16). Complex systems analysis: A necessary tool for homeland security. *The Backgrounder*, 2261, 1–7.
- Christensen, C. M. (2003). *The innovator's dilemma: The revolutionary book that will change the way you do business*. New York: Harper Business.
- Corman, S. R. (2005). Using networks to fight networks. *Communication, Terrorism & National Security Series*. Podcast by the Hugh Downs School of Human Communication, Arizona State University. Recorded March 25, 2005.
- Daft, R. L. (2009). *Organization theory and design* (10th ed.). Mason, OH: South-Western College Publisher.

- Davis, L. E. (2003). Defining the Army's homeland security needs. In L. E. Davis & J. Shapiro (Eds.), *The U.S. Army and the new national security strategy*. (pp. 61–83) Santa Monica, CA: Rand Corporation Publishing. Retrieved from [http://www.rand.org/pubs/monograph\\_reports/MR1657.html](http://www.rand.org/pubs/monograph_reports/MR1657.html)
- Davis, L. E., & Shapiro, J. (Eds.). (2003). *The U.S. Army and the new national security strategy*. Santa Monica, CA: Rand Corporation Publishing. Retrieved from [http://www.rand.org/pubs/monograph\\_reports/MR1657.html](http://www.rand.org/pubs/monograph_reports/MR1657.html)
- Department of Homeland Security. (2010, February). *Quadrennial homeland security review report: A strategic framework for a secure homeland*. Washington, DC. Retrieved from [http://www.dhs.gov/xlibrary/assets/qhsr\\_report.pdf](http://www.dhs.gov/xlibrary/assets/qhsr_report.pdf)
- DeYoung, K. (2009, December 31). Obama to get report on intelligence failures in Abdulmutallab case. *Washington Post On-line*. Retrieved from <http://www.washingtonpost.com/wp-dyn/content/article/2009/12/30/AR2009123003229.html>
- DHS: Progress and Priorities II. (2008, September 12). *Homeland Security Newswire*. Retrieved from <http://homelandsecuritynewswire.com/dhs-progress-and-priorities-ii?page=0,0>
- Donaldson, L. (2001). *The contingency theory of organizations*. Thousand Oaks, CA: Sage.
- Dooley, K. J. (1996). Complex adaptive systems: A nominal definition. *The Chaos Network*, 8(1), 2–3.
- Dooley, K. J. (1997). A complex adaptive systems model of organization change. *Nonlinear Dynamics, Psychology, and Life Sciences*, 1(1), 69–97.
- Federal Emergency Management Agency-FEMA. (2010, August 11). *FEMA History*. Retrieved from <http://www.fema.gov/about/index.shtm>
- Federation of American Scientists (FAS). (2010). Retrieved from <http://www.fas.org/irp/news/2001/12/chart.htm>
- France, P. (2006). Preventing terrorism using information sharing networks. (Master's thesis). Naval Postgraduate School, Monterey, CA.
- Frankel, M. (2011, January 3). The ABCs of HVT: Key lessons from high value targeting campaigns against insurgents and terrorists. *Studies in Conflict & Terrorism*, 34(1), 17–30. Retrieved from <http://tandfprod.literatumonline.com/doi/abs/10.1080/1057610X.2011.531456>
- Flyvbjerg, B. (2006, April). Five misunderstandings about case-study research. *Qualitative Inquiry*, 12(2), 219–245.

- Galbraith, J. R. (1973). *Designing complex organizations*. Reading, MA: Addison-Wesley Publishing Co.
- Galbraith, J. R. (1974). Organization design: An information processing view. *Interfaces*, 4(3), 28–36. Retrieved from <http://www.jstor.org/stable/25059090>
- Galbraith, J. R. (1977). *Organization design*. Reading, MA: Addison-Wesley Publishing Co.
- Galbraith, J. R. (2002, May). Organizing to deliver solutions. *Organizational Dynamics*. Center for Effective Organizations, Marshall School of Business, University of Southern California: Los Angeles, CA.
- Gardner, J. (2005, April 15). Preparing for disaster: L.A. County exercises ‘dirty bomb’. *International Association of Fire Chiefs—On Scene Magazine On-line*. Retrieved from <http://www.iafc.org/Operations/LegacyArticleDetail.cfm?ItemNumber=2201>
- Garvin, D. A. (1998, Summer). The processes of organization and management. *MIT Sloan Management Review*, 39(4), 33–50. Retrieved from <http://sloanreview.mit.edu/the-magazine/1998-summer/3943/the-processes-of-organization-and-management/>
- Gonzales, D., Hollywood, J., Sollinger, J. M., McFadden, J., DeJarnette, J. Harting, S., & Temple, D. (2007). *Networked forces in stability operations: 101st Airborne Division, 3/2 and 1/25 Stryker Brigades in Northern Iraq*. Santa Monica, CA: Rand Corporation Publishing.
- Gonzales, D., Johnson, M., McEver, J., Leedom, D., Kingston, G., & Tseng, M. (2005). *Network centric operations case study: The Stryker Brigade Combat Team*. Santa Monica, CA: Rand Corporation Publishing.
- Gordon, J., & Orletsky. (2003). Moving rapidly to the fight. In L. E. Davis & J. Shapiro, (Eds.), *The U.S. Army and the New National Security Strategy*. (pp. 191–216). Santa Monica, CA: Rand Corporation Publishing. Retrieved from [http://www.rand.org/pubs/monograph\\_reports/MR1657.html](http://www.rand.org/pubs/monograph_reports/MR1657.html)
- Grobman, G .M. (2005, Fall). Complexity theory: A new way to look at organizational change. *Public Administration Quarterly*, 351–384.
- Grossman, M. (2005). Perception or fact: Measuring the performance of the Terrorism Early Warning (TEW) group. (Master's thesis). Naval Postgraduate School, Monterey, CA.
- Hardy, G. H. (1999). *Ramanujan: Twelve lectures on subjects suggested by his life and work* (3rd ed.). New York: Chelsea.



- Holland, J. H. (1995). *Hidden order: How adaptation builds complexity*. New York, NY, USA: Basic Books.
- Holland, J. H. (1998). *Emergence: From chaos to order*. New York, NY, USA: Basic Books.
- Homeland Security on the Hustings. [Editorial] (2008, January 11). *The New York Times*. Retrieved from <http://www.nytimes.com/2008/01/11/opinion/11fri1.html>
- Homer-Dixon, T. (2002, January–February). The rise of complex terrorism. *Foreign Policy*. Retrieved from [http://www.foreignpolicy.com/issue\\_janfeb\\_2002/homer-dixon.html](http://www.foreignpolicy.com/issue_janfeb_2002/homer-dixon.html)
- Hosenball, M. (2010, January 2). The radicalization of Umar Farouk Abdulmutallab. *Newsweek On-line*. Retrieved from <http://www.newsweek.com/2010/01/01/the-radicalization-of-umar-farouk-abdulmutallab.html>
- Ito, H., & Lee, D. (2005). Assessing the impact of the September 11 terrorist attacks on U.S. airline demand. *Journal of Economics & Business*, 57, 75–95.
- Johnson, L. K., & Wirtz, J. J. (2008). *Intelligence and national security: The secret world of spies*. New York, NY, USA: Oxford University Press, Inc.
- Kamarck, E. C. (2002, June). Applying 21st-century government to the challenge of homeland security. New Ways to Manage Series. *John F. Kennedy School of Government Harvard University*.
- Kates, A., & Galbraith, J. R. (2007). *Designing your organization: Using the STAR model to solve 5 critical design challenges*. San Francisco: Jossey-Bass.
- Kean, T. H., & Hamilton, L. H. [Co-Chair]. (2004). *The 9/11 commission report: Final report of the National Commission on Terrorist Attacks upon the United States*. New York: W.W. Norton.
- Keeling, M. J., & Eames, K. T. D. (2005, June 20). Networks and epidemic models. *Journal of the Royal Society Interface*, 2, 295–307.
- Kiel, L. D. (1994). *Managing chaos and complexity in government: A new paradigm for managing change, innovation, and organizational renewal*. San Francisco, CA: Jossey-Bass Publishers.
- Kurtz, C. F., & Snowden, D. J. (2003). The new dynamics of strategy: Sense-making in a complex and complicated world. *IBM Systems Journal*, 42(3).
- Lawrence, P. R., & Lorsch, J. W. (1967). *Organization and environment: Managing differentiation and integration*. Boston, MA: Division of Research, Harvard Business School.

- Leavitt, H. J. (1965). Applied organizational change in industry: Structural, technical and humanistic approaches. In J. G. March (Ed.), *Handbook of organizations* (pp. 1144–1170). Chicago, IL: Rand-McNally.
- Leavitt, H. J. (2005). *Top down: Why hierarchies are here to stay and how to manage them more effectively*. Boston, MA: Harvard Business School Press.
- Levin, S. A. (2002, October 9). Complex adaptive systems: Exploring the known, the unknown and the unknowable. *Bulletin of the American Mathematical Society*, 40(1), 3–19.
- Lewis, T. G. (2006). *Critical infrastructure protection in homeland security: Defending a networked nation*. Hoboken, NJ: Wiley-Inter-Science.
- Lewis, T. G. (2007). How network science informs homeland security policy. (Unpublished paper and audio presentation). Naval Postgraduate School, Center for Homeland Defense and Security, Monterey, CA. Presentation retrieved from [https://www.chds.us/coursefiles/cip/audio/CS3660\\_Network\\_Science\\_Informs.m4b](https://www.chds.us/coursefiles/cip/audio/CS3660_Network_Science_Informs.m4b)
- Lewis, T. G. (2011). *Bak's sand pile: Strategies for a catastrophic world*. Williams, CA: Agile Press.
- Lichtblau, D. E., Haugh, B. A., Larsen, G. N., & Mayfield T. (2006, October). Analyzing adversaries as complex adaptive systems. IDA Paper P-3868. *Institute for Defense Analyses*, Alexandria, VA.
- Lowenthal, M. M. (2009). *Intelligence: From secrets to policy*. (4th ed.). Washington, DC: C.Q. Press.
- Marion, R., & Uhl-Bien, M. (2003). Complexity theory and Al-Qaeda: Examining complex leadership. Lawrence Erlbaum Associates, Inc. University of Nebraska at Lincoln, Management Department Faculty Publications. *Emergence*, 5(1), 54–76.
- MilitaryPhotos.net. (2008). Retrieved from <http://www.militaryphotos.net>.
- Miller, J. H., & Page, S. E. (2007). *Complex adaptive systems: An introduction to computational models of social life*. Princeton, NJ: Princeton University Press.
- Miller, P. (2005). *How can we improve information sharing among local law enforcement agencies?* (Master's thesis). Naval Postgraduate School, Monterey, CA.
- Mintzberg, H. (1979). *The structuring of organizations: A synthesis of the research*. Upper Saddle River, NJ: Prentice-Hall, Inc.

- Mintzberg, H. (1980, March). Structure in 5's: A synthesis of the research on organization design. *Management Science*, 26(3), 322–341.
- Mintzberg, H. (1994). *The rise and fall of strategic planning*. New York: The Free Press.
- Mintzberg, H. (2011). *Managing*. San Francisco, CA: Berrett-Koehler Publishers.
- Moffat, J. (2003). *Complexity theory and network centric warfare*. Information Age Transformation Series. Washington, DC: CCRP Publication Series.
- Nardulli, B. R. (2003). The U.S. Army and the offensive war on terrorism. In L. E. Davis, & J. Shapiro (Eds.). *The U.S. Army and the New National Security Strategy*. (pp. 27–60). Santa Monica, CA: Rand Corporation Publishing. Retrieved from [http://www.rand.org/pubs/monograph\\_reports/MR1657.html](http://www.rand.org/pubs/monograph_reports/MR1657.html)
- NSA Watch. (n.d.). American Civil Liberties Union. *Echelon*. Retrieved from <http://www.nsawatch.org/echelonfaq.html>
- Page, S. E. (2011). *Diversity and complexity*. Princeton, NJ: Princeton University Press.
- Paul, C., Thie, H. J., Watkins-Webb, K., Young, S., Clarke, C. p., Straus, S. G., Laha, J., Osowski, C., & Serena, C. C. (2011). *Alert and ready: An organizational design assessment of Marine Corps intelligence*. Santa Monica, CA: Rand Corporation Publishing. Retrieved from <http://www.rand.org/pubs/monographs/MG1108.html>
- Powley, E. H., & Nissen, M. E. (2009). Trust-mistrust as a design contingency: laboratory experimentation in a counterterrorism context. *International Command & Control Research & Technology Symposium*, Washington, DC: CCRP Publications.
- Rowley, C. (2002, June 3). Memo to FBI Director Robert Mueller, written May 21, 2002 and published in *Time Magazine*. Retrieved from <http://www.time.com/time/covers/1101020603/memo.html>
- Rust, S. M. (2006). *Collaborative network evolution: The Los Angeles terrorism early warning group?* (Master's thesis). Naval Postgraduate School, Monterey, CA.
- Schraagen, J. M. C., & Veld, M. H. in 't, de Koning, L. (2010, June). Information sharing during crisis management in hierarchical vs. network teams. *Journal of Contingencies and Crisis Management*, 18(2), 117–127.
- Senge, P. M. (2006). *The fifth discipline: The art and practice of the learning organization* (revised ed.). New York: Doubleday Publishing.
- Stake, R. E. (1995). *The art of case study research*. Thousand Oaks, CA: Sage Publications.

- Stephenson, W. D., & Bonabeau, E. (2007, February). Expecting the unexpected: The need for a networked terrorism and disaster response strategy. *Homeland Security Affairs*, III(1).
- Strauss, L. A., & Corbin, J. (1990). *Basics of qualitative research: Grounded theory procedures and techniques*. London: Sage.
- Sullivan, J. P. (2000). Integrated threat and net assessment: The L.A. Terrorism Early Warning (TEW) group model. *Prevention and Deterrence Conference*. Los Angeles.
- Sullivan, J. P. (2005, October 21). Terrorism early warning group and co-production of counter-terrorism intelligence. *Canadian Association for Security and Intelligence Studies-CASIS*. 20th Anniversary International Conference, Montreal, Quebec, Canada.
- Sullivan, J. P. (2010, March). Counter-supply and counter-violence approaches to narcotics trafficking. *Small Wars & Insurgencies*, 21(1), 179–195.
- Sullivan, J. P., & Bauer, A. (Eds.). (2008). *Terrorism early warning: 10 years of achievement in fighting terrorism and crime*. Los Angeles, CA: Los Angeles County Sheriff's Department.
- Tafoya, D. W. (2010). *The effective organization: practical application of complexity theory and organizational design to maximize performance in the face of emerging events*. New York, NY: Routledge Publishing.
- Toomey, C. J. (2003–2004, Winter). Army digitization: Making it ready for prime time. *Parameters: U.S. Army War College Quarterly*, 22(4), 40–53. Retrieved from <http://www.carlisle.army.mil/usawc/Parameters/Articles/03winter/toomey.htm>
- Treverton, G. (2008). *Reorganizing U.S. domestic intelligence: Assessing the option*. RAND Corporation.
- Trochim, T., & Donnelly, P. J. (2006). *The research methods knowledge base, 3e*.
- Tucker, D. (2008, June). Terrorism, networks, and strategy: Why the conventional wisdom is wrong. *Homeland Security Affairs*, IV(2), 1–18.
- Tushman, M. L., & Nadler, D.A. (1978, July). Information as an integrating concept in organizational design. *The Academy of Management Review*, 3(3), 613–624. Retrieved from <http://www.jstor.org/stable/257550>
- Vick, A., Orletsky, D., Pirnie, B., & Jones, S. (2002). *The Stryker Brigade Combat Team: Rethinking strategic responsiveness and assessing deployment options*. Santa Monica, CA: Rand Corporation Publishing.

- Waldrop, M. M. (1992). *Complexity: The emerging science at the edge of order and chaos*. New York, NY: Simon & Schuster.
- Wise, C. R. (2002, March–April). Organizing for homeland security. *Public Administration Review*, 62(2), 131–144. Published by Blackwell Publishing on behalf of the American Society for Public Administration.
- Wolfram Math World. *Chess games*. Retrieved from <http://mathworld.wolfram.com/Chess.html>
- Woodward, J. (1981). *Industrial organization: Theory and practice*. London: Oxford University Press. (Original work published 1965).
- Yin, R. K. (2009). *Case study research: Design and methods* (4th ed.). Thousand Oaks, CA: Sage Publications.

THIS PAGE INTENTIONALLY LEFT BLANK

## INITIAL DISTRIBUTION LIST

1. Defense Technical Information Center  
Ft. Belvoir, Virginia
2. Dudley Knox Library  
Naval Postgraduate School  
Monterey, California
3. Jacqueline Seabrooks, Chief of Police  
Inglewood Police Department  
Inglewood, California